

MAC-TR-12

MASSACHUSETTS INSTITUTE OF TECHNOLOGY

PROJECT MAC

THE MAC SYSTEM: A PROGRESS REPORT

by

R. M. Fano

October 9, 1964

ABSTRACT

The notion of machine-aided cognition implies an intimate collaboration between a human user and a computer in a real-time dialogue on the solution of a problem, in which the two parties contribute their best capabilities. In order for this intimate collaboration to be possible, a computer system is needed that can serve simultaneously a large number of people, and that is easily accessible to them, both physically and intellectually. The present MAC System is a first step toward this goal. The purpose of this paper is to present a brief description of the current system, to report on the experience gained from its operation, and to indicate directions along which future developments are likely to proceed.

Paper presented at the Symposium on Computer Augmentation of Human Reasoning, Washington, D. C., June 16, 1964. This paper will be published in the Proceedings of the Symposium and in the January 1965 issue of the IEEE SPECTRUM.

"Work reported herein was supported by Project MAC, an M. I. T. research program sponsored by the Advanced Research Projects Agency, Department of Defense, under Office of Naval Research Contract Nonr-4102(01). Reproduction in whole or in part is permitted for any purpose of the United States Government."

1964
OCT 15
A

THE MAC SYSTEM: A PROGRESS REPORT

INTRODUCTION

The notion of machine-aided cognition implies an intimate collaboration between a human user and a computer in a real-time dialogue on the solution of a problem, in which the two parties contribute their best capabilities. In order for this intimate collaboration to be possible, a computer system is needed that can serve simultaneously a large number of people and that is easily accessible to them, both physically and intellectually. The present MAC System is a first step towards this goal.

The case for machine-aided cognition with the aid of a multiple-access computer system was very eloquently argued by Professor John McCarthy in his 1961 lecture "Time-Sharing Computer Systems".¹ The views he presented were largely the consensus of a committee that had just completed a comprehensive study of the future computational needs of M. I. T. These concepts were also embodied in the Compatible Time-Sharing System (CTSS)² developed by the M. I. T. Computation Center under the leadership of Professor F. J. Corbato; an early version of this system was first demonstrated in November, 1961.³ The MAC computer system is a direct descendant of CTSS.

The last section of McCarthy's lecture introduced the notion of a community utility capable of supplying computer power to each "customer" where, when, and in the amount needed. Such a utility would be in some way analogous to an electrical distribution system. That is, it could provide each individual with logical tools to aid him in his intellectual work, just as electric tools today aid him in his physical work. In this regard, it might be said that the present state of the computer as a source of logical power is similar to that of the early steam engine as a source of mechanical power. The steam engine could generate much more power than could any man or animal, and therefore could perform tasks that were previously impossible. However, the power generated could not be supplied on an individual

¹ Superscripts refer to numbered items in the References.

basis to aid men in their daily work, until the advent of electrical power distribution.

The analogy between electric power and computer power illustrates only one of the aspects of a computer utility--namely, its ability to provide the equivalent of a private computer whose capacity is adjustable to individual needs. Of much greater importance to the individual customer would be the benefits that such a utility could make available to him by placing at his fingertips a great variety of services in the form of public procedures, data, and programming aids, and by allowing him to store and retrieve his own private files of data and programs. Furthermore, a computer utility could provide customers having common interests with convenient means for collaboration. For instance, designers working together on a complex system could check continually the status of the overall design as each of them develops and modifies his own contribution.

The MAC System is an experimental computer utility which, since November, 1963, has been serving a small but varied segment of the M.I.T. community. It is the most extensive of several time-sharing systems in operation.⁴⁻⁶ In spite of its experimental character and its limited capabilities, it has gained quick acceptance as a daily working tool. The purpose of this article is to present a brief description of the current system, to report on the experience gained from its operation, and to indicate directions in which future developments are likely to proceed. The scope is limited to the general organization of the system and to the basic services it can provide. In particular, no mention will be made of the problem-oriented languages and other special programming facilities that are being added to the system by the system users themselves, thereby increasing its intellectual accessibility. Thus the work reported here is only a small part of the overall research effort encompassed by Project MAC.

EQUIPMENT CONFIGURATION

The primary terminals of the MAC System are, at present, 52 Model 35 Teletypes and 56 IBM 1050 Selectric teletypewriters (adaptations of the "golfball" office typewriter). These are located mostly, but not exclusively, within the M.I.T. campus. Each of these terminals can dial, through the M.I.T. private branch exchange, either the IBM 7094 installation of Project MAC or the similar installation of the M.I.T. Computation Center. The supervisory programs of the two computer installations may, independently, accept or reject a call, depending on the identity of the caller. Access to the MAC System can also be gained from any station of the Telex or TWX telegraph networks. Some tests and demonstrations have been conducted from European locations, and experiments are being planned in collaboration with a number of universities to provide further experience with long-distance operation of the system.

Although Teletypes and other typewriter-like terminals are adequate for many purposes, some applications demand a much more flexible form of graphical communication. The MAC System includes for this purpose the initial model of a multiple-display system developed by the M.I.T. Electronic Systems Laboratory for computer-aided design.⁷ The system includes two oscilloscope displays with character generator and light pen, as well as some special-purpose digital equipment that performs the light-pen tracking, and simplifies the task of the computer in maintaining the display, and in performing common operations such as translating and rotating the display. The two oscilloscopes can be operated independently of each other; communication with the computer can be operated independently of each other; communication with the computer can be achieved by means of the light pen, and also through a variety of other devices such as knobs, push buttons, toggle switches, and a typewriter. The meaning of a signal from one of these input devices is entirely under program control. The whole display system communicates with the IBM 7094 of the MAC installation through the direct-data channel, and the display data are stored in the central memory of the 7094. Thus, the display must be located in a room

adjacent to the computer installation. Remote operation would require the addition of a memory and some processing capacity for local maintenance of the display.

A separate, very flexible display terminal is provided by a DEC PDP-1 computer which can communicate from a remote location with the MAC computer installation through a 1200-bit-per-second telephone connection. The PDP-1 can also be used as a buffer between the MAC computer and the display system just described above, thereby permitting simulation and study of remote operation of the latter.

All of these terminals can, in principle, operate simultaneously and independently of the MAC computer installation by time sharing its central processor. However, in order to insure prompt response, the number of terminals active at a given time is limited by the supervisory program to 24. This number has already grown to 24 from 10, and is expected to grow further and possibly to double in the next few months, although maximization of this number is not a primary objective at this time.

The equipment configuration of the MAC computer installation is illustrated in Fig. 1. The IBM 7094 central processor has been

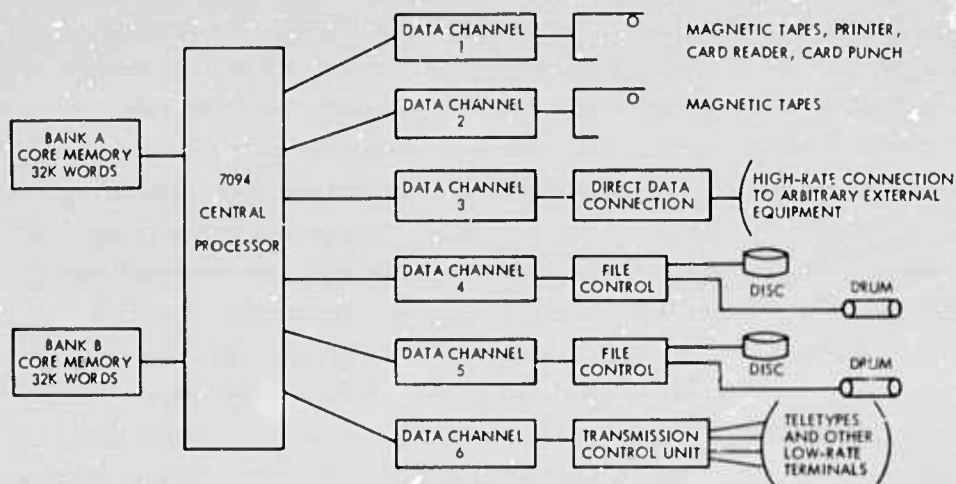

Fig. 1 Equipment Configuration

modified to operate with two 32,000-word banks of core memory and to provide facilities for memory protection and relocation. These features, together with an interrupt clock and a special operating mode (in which input-output operations and certain other instructions result in traps), were necessary to assure successful operation of independent programs coexisting in core memory. One of the memory banks is available to the users' programs; the other is reserved for the time-sharing system supervisory program. The second bank was added to avoid imposing severe memory restrictions on users because of the large supervisory program, and to permit use of existing utility programs (compilers, etc.), many of which require all or most of a memory bank.

The central processor is equipped with six data channels, two of which are used as interfaces to conventional peripheral equipment such as magnetic tapes, printers, card readers, and card punches. A third data channel provides direct-data connection to terminals that require high-rate transfer of data, such as the special display system.

Each of the next two data channels provides communication with a disc file and a drum. The storage capacity of each disc file is 9 million computer words, and the capacity of each drum is 185 thousand words. The time required to transfer 32,000 words in or out of core memory is approximately two seconds for the disc file and one second for the drum. The two disc files, with a total capacity of 18 million words, are used to store the users' private files of data and programs, as well as public programs, compilers, etc. The two drums are used for temporary storage of active programs that have to be moved out of the core memory to make room for other programs. Thus, in this respect they act as an extension of the core memory. Drums with transfer rates that are four-times faster will be substituted for the present ones in the near future.

The transmission control unit (IBM 7750) consists of a stored-program computer which serves as an interface between the sixth data channel and up to 112 communication terminals capable of telegraph-rate operation (approximately 100 bits per second). An appropriate number of these terminals are connected by trunk lines

to the M.I.T. private branch exchange and to the TWX and TELEX networks. Higher rate terminals can be readily substituted for groups of these low-rate terminals; for instance, on the present MAC System, three 1200-bit-per-second terminals are installed, one of which provides the communication channel to the PDP-1 computer. All of these terminals are compatible with Bell System Data-Phone data sets. Part of the core memory of the transmission control unit is used as an output buffer, because the supervisory program and its necessary buffer space have grown in size to the point of occupying the whole of the A bank of core memory. The design intent was and still is to provide sufficient input-output buffer space in the main memory to eliminate unnecessary core-to-core transfers; the present mode of operation is a makeshift made necessary by equipment limitations.

The Digital Equipment Corporation's PDP-1 computer is not an integral part of the MAC Time-Sharing System, except when connected to it as indicated above. It was acquired to permit early experimentation with light-pen interaction with a display, and for other very high speed interaction work. It includes a 16,000-word core memory, Microtapes, a high-speed channel, and a scope display with character generator and light pen. It will be replaced by a PDP-6 computer in the near future.

OPERATING PROGRAM

The operating program of the MAC Computer System is a direct descendant of the Compatible Time-Sharing System (CTSS) developed by the M.I.T. Computation Center, and described in the manual² published in July 1963. Many parts of the operating program have since been rewritten to facilitate system maintenance, and various facilities have been added that had been described in the manual but had not then been implemented. Furthermore, it now includes various user-developed features such as the I-O adapter for the display system described in the preceding section, compilers for various new languages, and other programming aids.

The heart of the MAC System is the supervisory program which resides at all times in the A bank of core memory. This program handles the communication with all the terminals, schedules the

```

login t193 fano
W 1036.4
PASSWORD
PARTY LINE BUSY, STANDBY LINE HAS BEEN ASSIGNED
T0193 2859 LOGGED IN 06/09/64 1036.7
CTSS BEING USED IS MAC05K
SHIFT MINUTES
    ALLOTTED    USED SINCE 06/09/64 1036.7
1         100         0.0
2         100         0.0
3         100         0.0
4         100         0.0
LAST LOGOUT WAS 06/09/64 1036.7
TRACK QUOTA= P, 500 Q. 0041 TRACKS USED.
R 5.550+1.000

```

Fig. 2a Print Out of Demonstration Session - Part a

```

Input
W 1038.3
00010      print format text,$ $
00020      print format text, $type range n1. to n2. on 2 lines $
00030      read" format b,fn1
00040      read format b, fn2
00050      n1=fn1
00060      n2=fn2
00070      print format text,$primes are$
00080      through loopb, for n=n1,1,n.g.n2
00090      whenebe n.1.3?whenev? whenever n.1.3, transfer to print
00100      throught loopa,for l=2,1,l.g.(n/l)
00110      through loopa,for l=2,1,l.g.(n/l)
00120      "loopa whenever (n-(n/l)*l).e.0,transfer to loopb
00130      print format a,n
00140 loopb continue
00150      print format text,$range finished$
00160      execute exit
00170      execute dormant""nt.
00180      vector values a=$(18)$
00190      vector values b=$(f20.8)$
00200      integer n,l,? vector values text=$(12a6)$
00210      integer n,l,n1,n2
00220      end of program
00230
MAN. delete,100
MAN. delete,160
MAN. file prime mad
d 1057.6
R .800+3.616

mad prime
W 1058.4

```

THE FOLLOWING NAMES HAVE OCCURRED ONLY ONCE IN THIS PROGRAM AND ARE ALL ASSIGNED TO THE SAME LOCATION. COMPILATION WILL CONTINUE.

```

PRINT
ERROR 02051 IN PART3. CARO NO. 00090
INVALID MOOE FOR SOME OPERANO IN PRECEOING STATEMENT
NO TRANSLATION.
R .600+.833

```

```

edit prime mad
W 1059.2
00230
MAN. 130 print print format a h""a,n
MAN. file prime mad
W 1101.1
R 1.066+1.200

```

Fig. 2b Print Out of Demonstration Session - Part b

time sharing of the central processor on the part of active programs, moves these programs in and out of core memory, and performs a variety of bookkeeping functions necessary to protect users' files and to maintain detailed accounting of the system usage. The services that the system can provide are organized in the form of commands, that is, instructions that system users can give to the system. The programs corresponding to the commands are permanently stored in the disc files; when a command is issued, a copy of the corresponding program is made, loaded, and executed just as if it were a user's program. The language facilities available in the system include FAP, MAD, MADTRAN (a translator of FORTRAN into MAD), COMIT, LISP, SNOBOL, a limited version of ALGOL, on-line, extended versions of SLIP and GPSS, and two problem-oriented languages for Civil Engineering named COGO and STRESS.

The system is rapidly evolving through the addition of new language facilities and other utility programs and programming aids. The operating program itself is now being modified by system programmers working on line, and modifications are occasionally introduced without even interrupting the operation of the system. The entire system, exclusive of users' files, includes approximately 1/2 million words of code, of which a little more than 50 thousand were specifically written for the system, and the rest are adaptations and modifications of compilers and other programming aids developed at M.I.T. and elsewhere.

Some of the basic services available from the system are illustrated in the six parts of Fig. 2 which represent a complete record of a demonstration session held on June 9, 1964 between 10:36 and 11:39 A.M. The total computer time used was 1.3 minutes. The author's typing appears in lower case letters, and the computer's replies are in capital letters. All digits represent computer replies except those intermixed with lower case text, and the two lines following "type range n1. n2. etc..." in Fig. 2(d). Each command is immediately acknowledged by the computer with a character W, followed by the time of the day in which the first two digits are hours, the next two are minutes, and the one following the period indicates tenths of a minute. The end of an interaction is indicated by the letter R,

followed by the sum of the two numbers indicating the total number of seconds of computer time used during the whole interaction. The first of the two numbers indicates the processing time, and the second represents the time wasted in swapping programs back and forth between core memory and drum.

The session was started by issuing the login command, followed by the author's problem number and name. The computer then asked for his password, which is not recorded because the printing mechanism of the typewriter is automatically disconnected while the password is typed. All the lines assigned to the author's user group were already in use. Therefore, a stand-by line was assigned because the total number of lines in use was less than 24. This condition introduced the possibility of an automatic logout of the author's problem. The rest of Fig. 2(a) contains various information, including the allotment of computer time in minutes which had been made that very morning, and of which none had yet been used.

Figures 2(b) and 2(c) illustrate some of the facilities for writing, editing, filing, and compiling programs and for retrieving and printing

```
mad prime
W 1105.4
LENGTH 00205, T.V. SIZE 00005, ENTRY 00043
R 2.400+1.000

printf prime mad
W 1106.0
00010          PRINT FORMAT TEXT,$ $
00020          PRINT FORMAT TEXT, $TYPE RANGE N1. TO N2. ON 2 LINES $
00030          READ FORMAT B, FN1
00040          READ FORMAT B, FN2
00050          N1=FN1
00060          N2=FN2
00070          PRINT FORMAT TEXT,$PRIMES ARE$
00080          THROUGH LOOPB, FOR N=N1,1,N.G.N2
00090          WHENEVER N.L.3, TRANSFER TO PRINT
00100          THROUGH LOOPA, FOR I=2,1,I.G.(N/I)
00110          WHENEVER (N-(N/I)*I).E.0, TRANSFER TO LOOPB
00120 LOOPA    PRINT FORMAT A,N
00130 PRINT
00140 LOOPB    CONTINUE
00150          PRINT FORMAT TEXT,$RANGE FINISHED$
00170          EXECUTE DORMNT.
00180          VECTOR VALUES A=$(I8)$
00190          VECTOR VALUES B=$(F20.8)$
00200          VECTOR VALUES TEXT=$(I2A6)$
00210          INTEGER N,I,N1,N2
00220          END OF PROGRAM
R .416+1.016
```

Fig. 2c Print Out of Demonstration Session - Part c

private files. The input command causes the computer to type out successive line numbers as each statement of the program is written. The program in Fig. 2(b), a corrected version of which is printed out in Fig. 2(c), can be used to compute prime numbers as illustrated in Fig. 2(d). The program is written in the MAD language. Some of the

```
load prime
W 1111.1
R 3.100+1.200

save prime
W 1111.4
R .866+.600

listf prime saved
W 1111.7
6/09/64 PRIME SAVED P 17
R .650+1.416

resume prime
W 1112.0
#EXECUTION.

TYPE RANGE N1. TO N2. ON 2 LINES
1000000.
1001000.
PRIMES ARE
1000003
1000033
1000037
1000039
1000081
1000099
1000117
1000121
1000133
1000151
1000159
1000171
1000183
1000187
1000193
1000199
1000211
1000- QUIT,
R 8.400+2.216
```

Fig. 2d Print Out of Demonstration Session - Part d

typing errors in Fig. 2(b) were intentional, others accidental. The quotation mark erases the preceding character and itself; thus, two successive quotation marks erase the preceding two characters. The question mark erases the entire line up to that point. Each line is terminated by giving a carriage return. A carriage return (i.e., entering a null line) is also used to enter the manual mode of input, as illustrated in line 230. In the manual mode, preceding lines can be deleted or corrected by issuing appropriate commands. After the deletion of two superfluous lines, the program was filed under the name Prime Mad as part of the author's private file.

Next, the mad command was issued to cause the program to be compiled by the MAD translator. The first attempt at compilation failed because of an error for which a diagnostic was printed. The error consisted of the omission of the word print in line 130. The edit command was then used to reopen the program file, the error was corrected in the manual mode, and the program was refiled under the same name. The second attempt to compile the program was successful, as indicated in Fig. 2(c), and the corrected program was then printed out using the printf command.

The binary version of the PRIME program was then loaded (together with the necessary library subroutines) by use of the load command, and the resulting core image and machine state were recorded by use of the save command. The latter command created a new file named PRIME SAVED, as indicated by the system reply to the command listf prime saved. The program was then started by issuing the command resume prime. It could also have been started by issuing the command start prime instead of save prime, or by loading and starting the program in one operation by means of the command loadgo prime.

The PRIME program asked for the numbers N1 and N2 defining the desired range of prime numbers; the numbers 1,000,000 and 1,001,000 were given. The typing out of the prime numbers was interrupted by pressing twice the break button on the Teletype, which resulted in the system's replying with the word QUIT.

The command listf without arguments causes the system to list the contents of the user's own private file directory as illustrated in

Fig. 2(e). There are four items with PRIME as first name: PRIME MAD, the original program shown in Fig. 2(c), PRIME BSS, its translation in machine language, PRIME MADTAB, a table (storage map) useful for debugging purposes and PRIME SAVED, the complete machine state after loading the program. The item named PRIMES MAD is a slightly different version of PRIME MAD.

Items are deleted from the file by issuing the delete command followed by the names of the items, as shown also in Fig. 2(e). The

```
llstf
W 1118.5
  10 FILES      31 TRACKS USED
DATE          NAME          MODE    NO. TRACKS
6/09/64      PRIME    SAVED    P        17
6/09/64      PRIME      BSS     P         1
6/09/64      PRIME  MADTAB    P         1
6/09/64      PRIME      MAD     P         1
6/08/64      MON04    SAVED    P        12
6/08/64      PRIMES   MAD     P         1
6/05/64      FILTER   SAVED    P        19
5/12/64      GSUBA    BSS     P         3
5/12/64      SCANA    BSS     P         3
5/08/64      SCANT    BSS     P         2
R .616+.800
```

```
delete prime saved prime bss prime madtab primes mad mon04 saved
W 1122.9
R 3.200+.400
```

```
delete *bss"" bss
W 1123.7
R 1.666+.200
```

```
llstf
W 1123.9
  2 FILES      21 TRACKS USED
DATE          NAME          MODE    NO. TRACKS
6/09/64      PRIME      MAD     P         1
6/05/64      FILTER   SAVED    P        19
R .616+.616
```

Fig. 2e Print Out of Demonstration Session - Part e

command delete, with an argument consisting of an asterisk followed by a space followed by a name, causes all items with the stated name as second name to be deleted. The result of issuing the two delete commands in Fig. 2(e) was the elimination from the file of all

items except PRIME MAD and FILTER SAVED, as indicated in the following printout of the file directory.

A program for monitoring the system operation, by the name of MONO4 SAVED, is available in the public file accessible to all system users. This program must first be copied into one's own private file by means of the copy p command, as shown in Fig. 2(f).

```
copy p mon04 saved
W 1125.9
#R 2.616+.400
```

```
resume mon04 1
W 1126.1
```

```
CTSS UP AT 902.8 06/09/64.
```

```
NUSERS= 22    TIME= 1126.2
29.7 29.7    BACKGROUND,
46.6 46.6    FOREGROUND,
17.6 17.6    SWAP TIME,
6.2 6.2     LOAD TIME,
15.5 15.5    USER WAIT,
6.6 6.6     SWAP WAIT,
3.9 3.9     LOAD WAIT.
```

```
NUSERS= 23    TIME= 1127.2
19.8 29.6    BACKGROUND,
43.6 46.5    FOREGROUND,
27.3 17.7    SWAP TIME,
9.3 6.2     LOAD TIME,
25.5 15.6    USER WAIT,
10.3 6.7    SWAP WAIT,
5.5 3.9     LOAD WAIT.
```

```
QUIT,
R .000+2.616
```

```
delete mon04 saved
W 1127.9
R 1.000+.400
```

```
logout
W 1138.9
T0193 2859 LOGGED OUT 06/09 /64 1139.1
TOTAL TIME USED= 01.3 MIN.
```

Fig. 2f Print Out of Demonstration Session - Part f

Since this program is stored as a record of a previous machine state, it is started by issuing the resume command. A second argument in the command (the digit 1) causes the program to be run at 1-minute intervals. At time 1126.2 there were 22 active users; 1 minute later there were 23. The other figures are percentages of the computer time devoted to various operations. FOREGROUND refers to the computer time devoted to running programs requested by on-line users. BACKGROUND refers to computer time available for running normal batch processing, which takes place automatically when no service is requested by on-line users. SWAP TIME is the processor time wasted in moving a program from core memory to drums and vice versa. LOAD TIME is the processor time devoted to loading programs from the disc files into core memory. The first four figures in each table add to 100 percent (or approximately so). The last three figures refer to the times in which the processor is totally idle while input-output operations are taking place. The USER WAIT is part of the foreground, and it is already included in the FOREGROUND figure. Similarly, SWAP WAIT and LOAD WAIT are already included in SWAP TIME and LOAD TIME. The figures in the second column of each table are percentages evaluated from the time at which the system was last placed in operation; for example, 902.8 in Fig. 2(f). The figures in the first column are percentages over the last 1 minute interval; in the first table they are identical to those in the second column.

After the monitor program was deleted from the file, the session was terminated by issuing the logout command. The session lasted approximately 1 hour, and was interrupted by two telephone calls lasting for a total of approximately 15 minutes. The total computer time used-swap and load time included- was 1.3 minutes.

The record of the demonstration session illustrates a few of the most basic commands of the MAC System. The total number of commands available to all users is, at present, 68. This number is continually increasing as new facilities developed by users as well as by the system programmers, are added to the system. In addition, a variety of programs of lesser general interest are available in the public file, from which they can be copied into private

files. This same public file is also used to facilitate the transfer of programs and data between system users. Among the special facilities available for operation of the display system are provisions for displaying text, for drawing on the screen, and for rotating three-dimensional objects. The public part of the system consists at present of approximately 1/2 million words of code. The users' private files barely fit into the two disc storage units whose total capacity is 18 million words.

OPERATING EXPERIENCE

The MAC System has been operating in roughly its present form since the middle of November, 1963. It is now in operation 24 hours a day, 7 days a week. Maintenance, disc dumping and loading, and occasional non-time-sharing operation require approximately 4 hours per day. The on-line use of the system has steadily increased since November to April; the total number of computer hours charged to on-line users (the sum of the numbers printed out by the system on completion of each command) was 311 in April and 297 in May. In other words, the computer time devoted to serving on-line users amounted to approximately 42 percent of total clock hours. The background use is not included in these figures. The total number of user-hours between login's and logout's turns out to be approximately 17 times the number of computer hours used.

The system is usually fully loaded (24 on-line users) during the day, and almost fully loaded in the evening until midnight and sometimes later. The system is very seldom idle even in the early morning hours.

Facilities for detailed monitoring of system operation have become available only very recently, and therefore no dependable data can be presented at this time. It must be stressed in this regard that it is far from obvious what measurements would provide a useful characterization of the system performance, in view of the many variables involved, and of the complexity of their interactions. Furthermore, the frequency and character of user requests vary with time, they are highly unpredictable, and of course cannot and should not be restricted or controlled in any realistic measurement of system performance.

The performance figure of greatest interest to the user is the response time (the time interval between the issue of a request and the completion on the part of the computer of the requested task) as a function of the bare running time of the corresponding program. The response time depends on the scheduling algorithm employed by the system, as well as on the number and character of the requests issued by other users.

The scheduling algorithm operates roughly as follows: Each user request is assigned an initial priority which depends only on the size of the program that must be run. The highest priority is assigned to the smallest programs. The highest priority programs are allowed to run for a maximum of 4 seconds before being interrupted, whereas lower priority programs are allowed to run for longer intervals which are multiples of 4 seconds. The lower the priority, the longer is the allowed interval. If a program run is not completed within the allowed interval, the program is transferred from core memory to drum (the state of the machine being automatically preserved), and its priority is reduced by 1 unit.

The curves of Fig. 3 illustrate the behavior of the wait time and swap time as a function of program run time for programs 50 words long and 25,000 words long. The swap time is defined for this purpose as the time spent in transferring the program between disc file and drum on the one hand, and core memory on the other; wait time is the time during which the computer is performing tasks that are not pertinent to that program. Obviously, the total response time is the sum of the bare run time (the abscissa in Fig. 3), the swap time, and the wait time. The points in Fig. 3 were obtained from measurements performed by M. Jones, and the curves are rough interpolations between the points. Each point represents the average value of 30 consecutive measurements. The number of users during the time that the measurements were being made varied from a low of 13 to a high of 21; it was between 17 and 20 most of the time. The scattering of the points in Fig. 3, together with the variability of the number of users while the measurements were being performed, should make clear the kind of difficulties one faces in obtaining precise and accurate measurements of system performance.

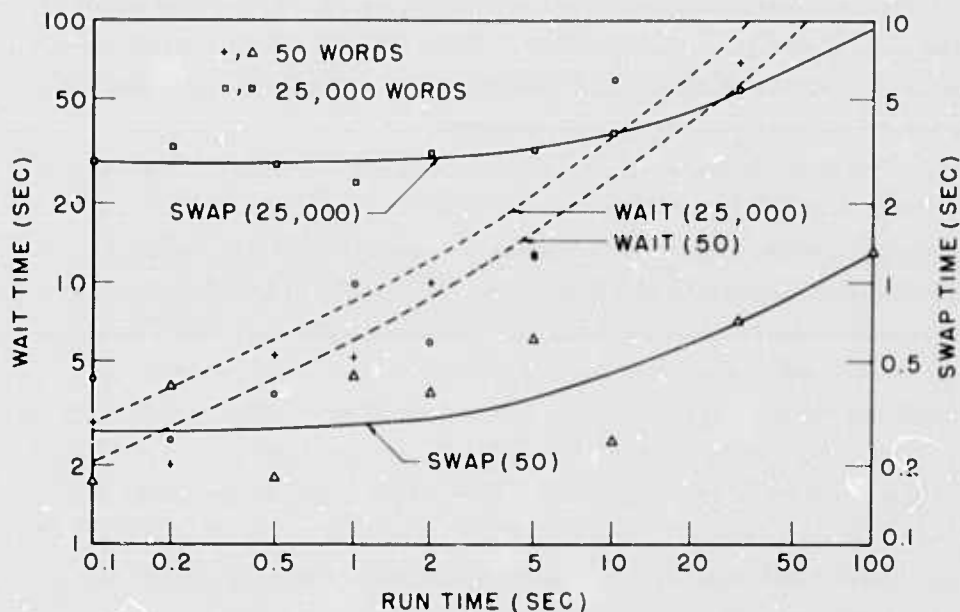

Fig. 3 Behavior of Wait Time and Swop Time as Functions of Run Time

It is clear from Fig. 3 that the swap time constitutes a large overhead for short runs. The swap time is defined in this figure to include also the initial transfer of the program from disc file to core memory and the final transfer back into the disc file; the two-way transfer of 32,000 words between disc file and core memory takes approximately 4 seconds, and the same transfer between drum and core memory takes approximately 2 seconds. The wait time increases less than linearly with run time, and, as expected, is not greatly affected by the size of the program.

The MAC computer installation has experienced a normal number of hardware failures. It should be realized however, that hardware failures are much harder to diagnose in a multiple-access system, because of the impossibility of reproducing the machine conditions at the time of failure. Moreover, the probability distribution of machine states in a multiple-access operation is quite different from that in a batch-processing operation; therefore hardware troubles that become apparent in the former mode of operation

often go unnoticed in the latter. Above all, it is often very difficult to determine whether a particular malfunctioning is the result of a hardware failure, a system-programming error, or even an error in the logical design of the machine. There is no doubt that multiple-access systems present substantially more difficult maintenance problems than do conventional systems.

The most delicate aspect of the operation of a multiple-access system of the MAC type is the responsibility assumed by the system managers with respect to the users' programs and data that are permanently stored in the disc files. Elaborate precautions must be taken to protect the contents of the disc files against malfunctioning of the system, as well as against actions of individual users. The supervisory program restricts the access of each user to his own private file, and to public files which he can not modify. A full copy of the contents of the disc file is made twice a day to minimize the loss in case of malfunctioning. While losses of users' programs and data have occurred, their frequency and seriousness have not discouraged users from entrusting their work to the system.

The system users number a little more than 200, with 10 academic departments represented among them. Although most users have had previous experience in programming, there is a growing group of users who are working entirely with programs developed by others, or through high-level problem-oriented languages that enable them to communicate with the system in an English-like language appropriate to their professional field.⁸⁻¹¹

Enthusiasm mixed with a great deal of frustration is the most common reaction to the system on the part of its users. The system was very quickly accepted as a daily working tool, particularly by computer specialists. This quick acceptance, however, was accompanied by the kind of impatience with failures and shortcomings that is characteristic of customers of a public utility. The capacity of the system is limited, and therefore users are often unable to log in because the system is already fully loaded. Furthermore the system may not be in operation because of equipment or programming failures, just when one is planning to use it. In other words, the system is far from being as reliable and dependable as a utility

should be. Yet, the experience since last November has shown that it is perfectly feasible for a computer system to be the object of research and development for some people and, simultaneously, an effective working tool for others. System experimentation and use are not only compatible but mutually beneficial.

It is becoming increasingly evident that the system's ability to provide the equivalent accessibility of a private computer is only a secondary, although necessary, characteristic. What users find most helpful is the fact that the system places literally at their fingertips a great variety of services for writing, debugging and compiling programs, and facilities for working on problems in their own fields through appropriate problem-oriented languages.

The system users themselves are beginning to contribute to the system in a substantial way by "publishing" their work in the form of new commands. As a matter of fact, an editorial board is being established to review such work and formally approve its inclusion in the system. Thus, the system is beginning to become the repository of the procedural and data knowledge of the community that it serves. A corollary of this trend is, of course, the increasing difficulty that users find in ascertaining what facilities of interest to them are included in the system. In other words, the system is beginning to have the undesirable as well as the desirable characteristics of a library.

SYSTEM TRENDS

The organization of the MAC System appears to be at the threshold between two basically different points of view on computer systems and their utilization. The traditional view is that of a processor serving one user at a time and executing programs in succession, with a negligible amount of interaction during execution with the user himself or any other part of the outside world. A corollary of this view is that the processor, the memory, and the peripheral equipment must be designed to fit the requirements of the "typical user" rather than the average requirements of users as a group. Thus, the system as a whole can be used efficiently only by specifically tailoring programs to its peculiarities.

The present MAC System is still organized in a traditional manner in the sense that programs, whether public or private, are executed in succession as independent and indivisible entities. The fact that one program may be interrupted by a higher priority program is irrelevant for the purposes of the present discussion. For instance, the execution of a system command generates a copy of the corresponding program (stored in the disc file), which is then run just as if it were a user program. Thus, if several users are simultaneously compiling programs written in the same language, several copies of the same compiler are simultaneously and independently shuttling back and forth between core memory and drum. Another consequence is that any interactive program must be present in main memory in its entirety when data or instructions are needed from the user, even though the presence of one or two of its subroutines may be sufficient to accomplish the interaction.

A further and very serious aspect of the present mode of operation is that only one complete, executable user program can reside in core memory at any one time. The implication is that the central processor must remain totally idle while a new program is being transferred into core memory or while necessary input-output operations are taking place. The idle time is very substantial in the present MAC System, as indicated by the WAIT percentages in Fig. 2(f).

These system inadequacies are clearly the result of an organization keyed to the traditional point of view of a central processor executing independent programs one at a time. Furthermore, the characteristics of the present equipment would preclude in practice, if not in principle, any substantially different system organization. In order to overcome these limitations, one must approach the system design problem from a point of view considerably different from the traditional one.^{12, 13} We observe in this regard that even the term "time-sharing" is inappropriate and somewhat misleading, because it emphasizes the necessary but secondary goal of providing the equivalent of a private computer. The term "multiple access" is also misleading when it is applied to the central processor. The emphasis should instead be on the system ability to provide convenient

and flexible multiple access to an ever-changing structure of procedures and data capable of interacting as parts of distinct processes. In other words, it is the software structure that is important, and the hardware assumes the secondary role of providing convenient means for access to it.

If the system goal is to provide convenience of access to such a software structure, one is naturally led to view the system itself as memory centered rather than processor centered. Furthermore, the memory that forms the heart of the system would be not the main core memory, but the bulk memory, consisting of disc files or similar devices in which the procedures and data are normally stored. The main memory would play, instead, the role of a giant buffer matching the relatively low transfer rate of the bulk memory to the fast processing rate of processors and input-output channels. When the system is looked at from this point of view, it assumes the appearance more of a message-store-and-forward communication system, than of a traditional computer system. Indeed, the smooth flow of messages is of paramount importance to efficient operation; thus, the major function of the supervisory program is to organize the transfer of messages (procedures, data, as well as input-output messages) in such a way as to avoid unnecessarily long queues, and to insure efficient utilization of the available equipment.

It is also clear that a computer system intended to serve a large number of people simultaneously must be organized so that it will avoid any unnecessary duplication of information in either main or bulk memory, and unnecessary transfers between the two. This statement implies that procedures and data must be executable as common parts of processes that have been simultaneously and independently initiated by different users. It also implies the possibility of executing processes involving several subroutines in such a manner that only the necessary subroutines are in core memory at any given time. The program segmentation scheme advocated by J. B. Dennis is keyed to these objectives.¹³

A corollary to this view of a computer system is the functional subdivision of the hardware into pools of equipment serving the same function, with each piece of equipment being duplicated to meet the average system demand. The point here is that, if the objective of

the system is to provide convenient access to the procedures and data stored in the bulk memory, enough equipment must be provided to perform the necessary functions, so that a bottleneck in one part of the system will not prevent the full utilization of other parts. The equipment itself can then be designed to match the average demand of users as a group, rather than the requirements of the "typical users". Furthermore, if each piece of equipment is duplicated within the system, one can envision the achievement through on-line maintenance of a level of reliability and continuity of operation that is unthinkable for the present MAC System.

In conclusion, the experience with the present MAC System suggests a trend toward memory-centered, as opposed to processor-centered, systems, including pools of bulk memories, core memories, central processors, and input-output channels, all communicating with one another, with the core memories acting as buffers. On the software side, the trend seems to be in the direction of executing processes that consists of many subroutines and data structures which are never assembled into a single program, and some of which may be common to other independent processes simultaneously in execution. This view of computer systems is indeed very different from the traditional one. Its implications are far from clear. Their exploration is a major objective in the development of the next MAC System.

ACKNOWLEDGEMENTS

This paper reports on the accomplishments and ideas of a great many people associated with Project MAC, far too many to list them individually. However, special credit is due to Professor J. F. Corbato, Deputy Director of the M. I. T. Computation Center, and to his staff who developed the Compatible Time-Sharing System, and who are mainly responsible for its evolution into the present MAC System. It is a pleasure to be their spokesman, a pleasure mixed with fear of having failed to do full justice to their work.

The successful operation of a computer utility during its first year of existence is an accomplishment of which all those concerned with the system management and maintenance can be rightly proud.

Their devotion to the goal of continuous operation has often extended far above and beyond the call of duty.

The financial support of the Advanced Research Projects Agency of the Department of Defense, and the managerial support of the Office of Naval Research are gratefully acknowledged. Their confidence and interest in Project MAC are a constant source of encouragement. In particular, I wish to express my personal gratitude to Dr. J.C.R. Licklider whose technical vision and contagious enthusiasm as Assistant Director of ARPA were responsible for the initiation of Project MAC.

Finally, I wish to express my gratitude to the I. B. M. Corporation, and in particular to Mr. Loren Bullock, its long-time representative at M. I. T., for their helpful cooperation in planning and implementing equipment modifications to meet the special needs of the MAC System. I am similarly grateful to the New England Telephone and Telegraph Company for its help and cooperation in engineering the Teletype network in the MAC System.

REFERENCES

1. J. McCarthy, "Time-Sharing Computer Systems," Management and the Computer of the Future, (Edited by M. Greenberger), 221-236, The M.I.T. Press, Cambridge, Mass. (1962).
2. The Compatible Time-Sharing System, A Programmer's Guide, by the M.I.T. Computation Center, the M.I.T. Press, Cambridge, Mass. (1963).
3. F.J. Corbato, M.M. Daggett and R.C. Daley, "An Experimental Time-Sharing System," AFIPS Conference Proceedings, Vol. 21, 335-344, (1962).
4. S. Boilen, E. Fredkin, J.C.R. Licklider, and J. McCarthy, "A Time-Sharing Debugging System for a Small Computer," AFIPS Conference Proceedings, Vol. 23, 51-57, (1963).
5. J. Schwartz, "A General-Purpose Time-Sharing System," AFIPS Conference Proceedings, Vol. 25, 397-411, (1964).
6. J.B. Dennis, "A Multiuser Computation Facility for Education and Research," Communications of the ACM, Vol. 7, 521-529, Sept. 1964.
7. R. Stotz, "Man-Machine Console Facilities for Computer-Aided Design," AFIPS Conference Proceedings, Vol. 23, 323-328, (1963).

8. D.T. Ross and C.G. Feldman, "Verbal and Graphical Language for the AED System: A Progress Report," Technical Report MAC-TR-4, M.I.T., 1964.
9. J.M. Biggs and R.D. Logcher, "Stress: A Problem-Oriented Language for Structural Engineering," Technical Report MAC-TR-6, M.I.T., 1964.
10. J. Weizenbaum, "OPL-1: An Open-Ended Programming System Within CTSS," Technical Report MAC-TR-7, M.I.T., 1964.
11. M. Greenberger, "The OPS-1 Manual," Technical Report MAC-TR-8, M.I.T., 1964.
12. F.J. Corbato, "System Requirements for Time-Shared Computers," Technical Report MAC-TR-3, M.I.T., 1964.
13. J.B. Dennis, "Program Structure in a Multi-Access Computer," Technical Report MAC-TR-11, M.I.T., 1964.