

605 616

IIT RESEARCH INSTITUTE
Technology Center
Chicago 16, Illinois

Contract NOw 64-0140-c

HIGH-TEMPERATURE OXIDATION-PROTECTIVE
COATINGS FOR VANADIUM-BASE ALLOYS

IITRI-B6019-5
(Bimonthly Report)

June 1, 1964 - July 31, 1964

COPY	<u>2</u>	OF	<u>3</u>	
HARD COPY				\$. 1.00
MICROFICHE				\$. 0.50

20 y

Department of the Navy
Bureau of Naval Weapons
Washington 25, D. C.

September 1, 1964

HIGH-TEMPERATURE OXIDATION-PROTECTIVE
COATINGS FOR VANADIUM-BASE ALLOYS

ABSTRACT

The objective of this program is the development of oxidation-protective coatings for vanadium-base alloys for use at 1800° to 2500° F. The effect of pack-siliconizing on the mechanical properties of 0.020 in. thick sheet of V-60Cb-1Ti (weight per cent) is being studied. Results indicate that the siliconizing process has little effect on strength, but causes some reduction in tensile ductility. However, good ductility is noted at temperatures as low as -320° F. Preliminary results indicate that there is no embrittlement of this coated sheet after twenty-five 4-hr oxidation cycles at temperatures up to 2300° F.

The development of an oxidation resistant slurry or liquid cementation type of coating for V-60Cb-1Ti is progressing. Slurry compositions containing tin, silicon, silver, copper, aluminum, and columbium have been investigated; several of these show good coverage, even at corners and edges.

The static oxidation life of other vanadium-base alloys, coated by the pack-siliconizing process, is also being investigated. V-40Cb-30Ta-1Ti, the most promising of these alloys, has an oxidation life of about 50 hr at 2200° F, and less under cyclic conditions.

TABLE OF CONTENTS

	<u>Page</u>
I. INTRODUCTION	1
II. EXPERIMENTAL RESULTS	2
A. Influence of the Pack Silicide Coating and Coating Process on the Mechanical Properties of V-60Cb-1Ti	2
B. Development of Slurry and Liquid Cementation Type Coatings for 0.020 in. V-60Cb-1Ti Sheet	10
C. Pack-Siliconizing Studies of Other Vanadium- Base Alloys	10
III. FUTURE WORK	13
IV. LOGBOOKS AND PERSONNEL	16

HIGH-TEMPERATURE OXIDATION-PROTECTIVE
COATINGS FOR VANADIUM-BASE ALLOYS

I. INTRODUCTION

This is the fifth bimonthly progress report on IITRI Project B6019, "High-Temperature Oxidation-Protective Coatings for Vanadium-Base Alloys," covering the period June 1 to July 31, 1964. This program is a continuation of work previously conducted under Contract NOw 61-0806-c and N600 (19)-59182.

In previous work, pack-siliconizing coating processes were developed to protect vanadium-base alloys from oxidation at temperatures between 1200° and 2800° F. Pack parameters were established for coating various sizes of specimens of V-60Cb and V-20Cb base alloys. In addition, the applicability of the coating process to other high-strength alloys currently under development ** was also investigated. Coating performance was evaluated in static air in an oxygen-hydrogen flame, at reduced pressures, and under stress. Also, coated samples have been supplied to various laboratories and aerospace organizations participating in a data exchange program + for further evaluation. The results to date are quite encouraging and indicate considerable potential for the coated vanadium alloys in a variety of aerospace applications.

The current program has several objectives; the major ones are as follows:

- (1) Determination of the influence of the coating and process on the mechanical properties of alloys.
- (2) Influence of stress on coating performance.
- (3) Development of a slurry coating process.
- (4) Further evaluation of the influence of selected environments (i. e., low pressure, high air mass flow) on coating performance.

* Compositions are reported in weight per cent.

** Contract No. NOw 64-0239-c

+ Contract No. NOw 62-0101-c

II. EXPERIMENTAL RESULTS

A. Influence of the Pack Silicide Coating and Coating Process on the Mechanical Properties of V-60Cb-1Ti

This portion of the program is concerned mainly with the influence of the coating and coating process on the mechanical properties of vanadium-columbium alloys during high-temperature exposure in a wide variety of environments, such as static, dynamic, and reduced pressure oxidizing environments. The influence of stress on the coating under these conditions is also being studied.

Mechanical properties of the uncoated V-60Cb-1Ti alloy at temperatures between -320° and 2700° F have been reported under Contract No. NOW-62-0101-c, "Pilot Evaluation of Vanadium Alloys," Final Report IITRI-B231-10, January, 1964.

The determination of mechanical properties of coated V-60Cb-1Ti, both before and after oxidation exposure, is currently in progress. A standard pack-siliconizing process is being used for coating all specimens. The processing technique explained in detail is as follows:

- (1) Crush and screen to -35, +100 mesh high-purity silicon, wash in distilled water to remove soluble impurities and fines.
- (2) Bake the silicon at 350° F for at least 12 hr.
- (3) Barrel tumble the specimens to be coated for 100 hr in a water-alumina grit slurry to produce a uniform 5 mil radius on all edges and corners.
- (4) Clean the specimens in 25 HNO_3 - 5HF - $70\text{H}_2\text{O}$ with a subsequent water and acetone rinse.
- (5) Thoroughly blend the activator, which has been kept under a desiccator of phosphorus pentoxide, with the silicon immediately before placing in the retort.
- (6) Evacuate the retort to less than 5×10^{-5} mm and pump on the system in this condition for a minimum of 12 hr. The leak rate after this time must be less than 5×10^{-4} mm per min.
- (7) Backfill with high-purity argon which has been passed over hot titanium chips.
- (8) Siliconize for 8 hr at 2150° F under the static argon atmosphere.

IIT RESEARCH INSTITUTE

The silicon used throughout this program was received as 1/4 in. chunks, and was crushed in a ceramic crucible at the Research Institute. Since little or no sintering of the silicon occurs, the powder is screened, washed, and used again. A chemical analysis of a representative sample of this reused silicon is shown in Table I.

Figure 1 is a schematic drawing of the retort used for the pack-siliconizing studies. Note that two small glazed zircon supports remain as the only nonmetallic constituents inside the retort.

The amount of activator blended with the silicon depends on the alloy being coated, the activator being used, and to some extent on the ratio of the size of the pack to the volume of the retort. Coating V-6Cb-1Ti using the above procedure requires a 1% addition of sodium fluoride to produce a 2.5-3.0 mil coating.

In the last bimonthly report, tensile data were presented for samples of V-60Cb-1Ti tested in the uncoated condition at 70° and -320° F and in the as-coated condition at 70° and 32° F. Table II gives the results of continued tests in the as-coated condition, as well as in a post-oxidation state. These tests were performed on an Instron Universal Testing Machine, using a strain rate of 0.0057 in/in/min. . Specimen geometry was given in the last bimonthly report.

The samples that were tested during this report period in the as-coated condition were either annealed before coating in a vacuum of 5×10^{-6} mm for 1 hr at 2200° F or were in a cold-rolled condition at the time of coating, as indicated in Table II. There appears to be no difference in the samples coated in the cold-rolled or the fully annealed condition, except that the siliconized cold-rolled specimens were slightly warped, whereas the coated fully annealed samples remained flat and undistorted.

Strength data for samples tested in the coated condition are given on the basis of total cross-sectional area and on the area of the substrate material alone. The silicide coating was determined to be approximately 2.5 mils per side in the as-coated condition, and this value was used in all calculations.

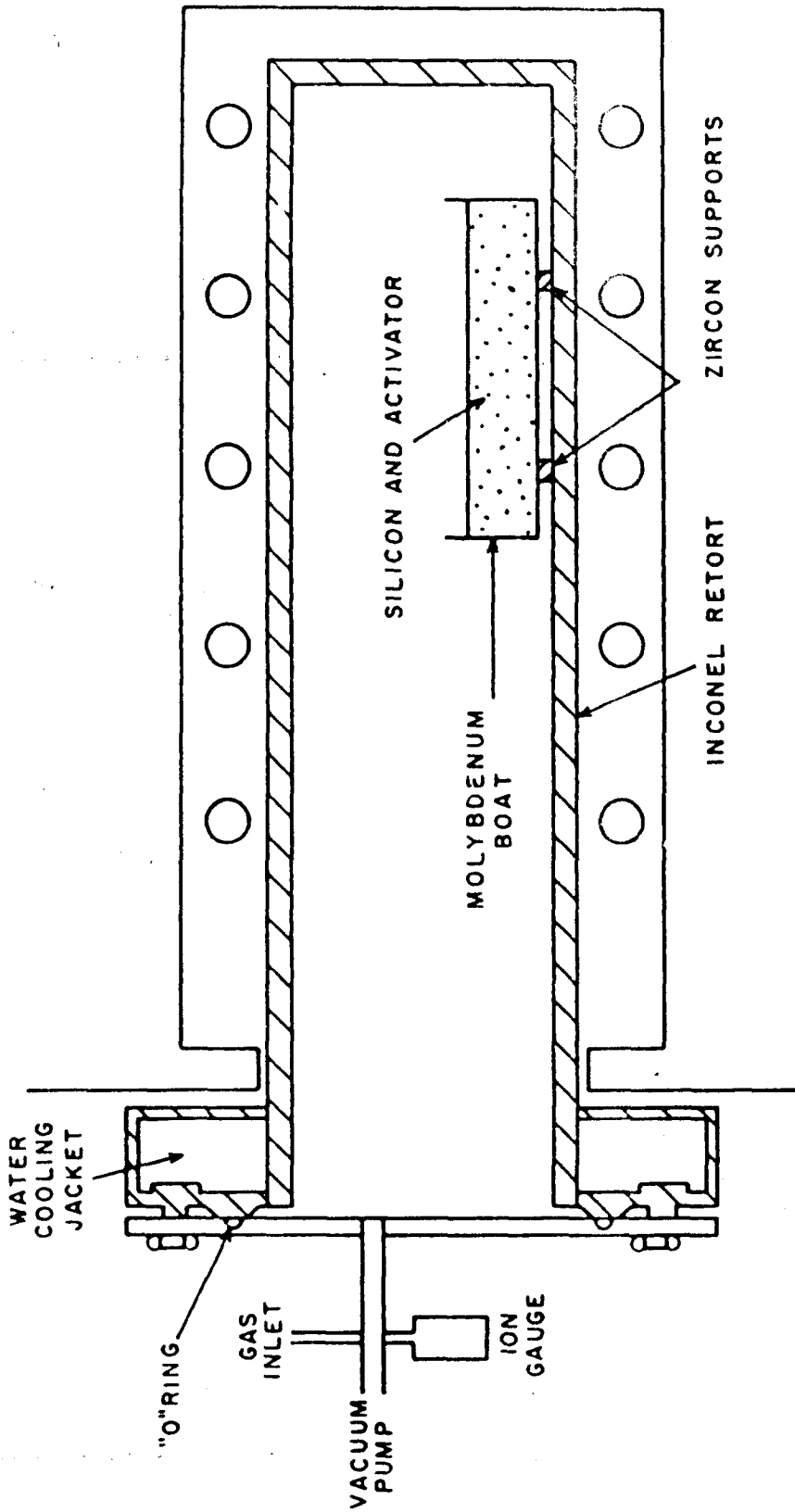

FIG. 1 - SCHEMATIC DRAWING OF RETORT DESIGN USED IN THE PACK-SILICONIZING PROCESS.

IIT RESEARCH INSTITUTE

TABLE I

SPECTROGRAPHIC QUALITATIVE ANALYSIS OF
SILICON USED FOR PACK SILICONIZING*

Element	Per cent
Silicon	10.0 - 100.0
Aluminum	.01 - .1
Copper	.01 - .1
Magnesium	.01 - .1
Iron	.005 - .05
Nickel	.001 - .01
Lead	.005 - .05
Tin	.001 - .01
Zinc	.001 - .01
Manganese	not detected
Chromium	not detected

* Analysis performed by Charles C. Kawin Co.

TABLE II

TENSILE TEST DATA FROM 0.020 in. V-60Cb-1Ti SHEET

Material Condition	Test Temp., °F	Yield Strength, psi	Ultimate Tensile Strength, psi	Elongation %
As-Coated (Coated cold-rolled)	32	77,400 (a) 100,000 (b)	96,500 (a) 125,500 (b)	4.0
As-coated (Annealed before coating)	32	79,200 (a) 103,000 (b)	102,000 (a) 132,500 (b)	6
As-coated (Coated cold-rolled)	-320	68,700 (a) 87,000 (b)	155,000 (a) 196,000 (b)	21
As-coated (Coated cold-rolled)	-320	78,000 (a) 100,000 (b)	145,500 (a) 188,000 (b)	20
As-coated (Annealed before coating)	-320	79,900 (a) 103,500 (b)	140,500 (a) 182,000 (b)	11
As-coated (Annealed before coating)	-320	82,200 (a) 106,000 (b)	168,000 (a) 218,000 (b)	23
Uncoated (Vacuum treated for 8 hr at 2200° F)	70	110,000	120,500	25
Uncoated (Vacuum treated for 8 hr at 2200° F)	70	92,700	117,000	15 (c)
Uncoated ^(d) (Vacuum treated for 8 hr at 2200° F)	70	107,000	136,000	25
Post-Oxidation (Ten 2-hr cycles at 2300° F 100 μ Hg pressure)	70	74,000 (a) 98,000 (b)	107,000 (a) 141,500 (b)	15 (e)

TABLE II (Continued)

Material Condition	Test Temp., °F	Yield Strength, psi	Ultimate Tensile Strength, psi	Elongation %
Post-Oxidation (Eight 4-hr cycles at 2100° F in laboratory air)	70	81,000 (a) 105,500 (b)	103,500 (a) 135,000 (b)	20
Post-Oxidation (Eight 4-hr cycles at 2100° F in laboratory air)	70	78,500 (a) 102,500 (b)	97,500 (a) 127,000 (b)	15
Post-Oxidation (Nineteen 4-hr cycles at 2100° F in laboratory air)	70	57,000 (a) 74,800 (b)	81,200 (a) 106,800 (b)	14 (c)
Post-Oxidation (Twenty-five 4-hr cycles at 2100° F in laboratory air)	70	76,000 (a) 99,400 (b)	98,400 (a) 128,500 (b)	24
Post-Oxidation (Twenty-five 4-hr cycles at 2100° F in laboratory air)	70	70,500 (a) 91,000 (b)	92,400 (a) 119,500 (b)	23
Post-Oxidation (Eleven 4-hr cycles at 2300° F in laboratory air)	70	71,000 (a) 93,000 (b)	86,700 (a) 113,800 (b)	10
Post-Oxidation (Eleven 4-hr cycles at 2300° F in laboratory air)	70	73,200 (a) 97,200 (b)	94,000 (a) 125,000 (b)	14

- (a) Stress calculated from the total area of the coated sample.
- (b) Stress calculated from the area of only the substrate.
- (c) Sample was not uniformly thick; most of the elongation as well as the fracture occurred at the thin end.
- (d) Higher strain rate of 0.05 in/in/min.
- (e) Hot zone from resistance heating was smaller than gage length consequently elongation was not uniform throughout gage length.

The ultimate tensile strength of the alloy in the uncoated annealed condition at 70° and -320° F is about 130,000 and 228,000 psi with an elongation of 20 and 29%, respectively. The material tested in the as-coated condition had a tensile strength at 70° and -320° F of about 130,000 and 190,000 psi with 10 and 20% elongation, respectively.

This indicates that either the presence of the coating, the 8 hr treatment at 2150° F, or contamination from the coating process has affected the V-60Cb-1Ti to some extent, although the transition is still below -320° F after coating. The greater elongation at -320° F than at ambient temperatures in the cold-rolled, annealed, coated, and uncoated condition has been noticed consistently.

To determine if the loss of strength and ductility was a result of the 8 hr heat treatment that the specimens undergo during coating, several samples were vacuum heat-treated for 8 hr at 2150° F. Figure 2 shows the microstructure of the alloy after this time. Figure 3 shows the microstructure of the alloy in the as-coated condition. Although there is some increase in grain size, it cannot be attributed directly to the prolonged heat treatment, nor can the loss of strength and ductility since the tensile strength of the vacuum treated samples is about 120,000 psi with an elongation of 25%; this is almost identical to the results after a 1 hr anneal.

Tests are being completed at the present time on samples which have received varied high-temperature exposures. Preliminary results indicate that there is no embrittlement after prolonged cyclic exposure to laboratory air at 2100° and 2300° F. There appears to be some loss in strength, but this may be caused by an increase in coating thickness during exposure, which was not taken into account when determining the cross-sectional area.

It is also interesting to note that as of this date there have been no premature oxidation failures; however, all samples used were given a thorough visual inspection both before and after coating for any possible defects. Inspection was made under a variable power 7-30 X binocular microscope.

IIT RESEARCH INSTITUTE

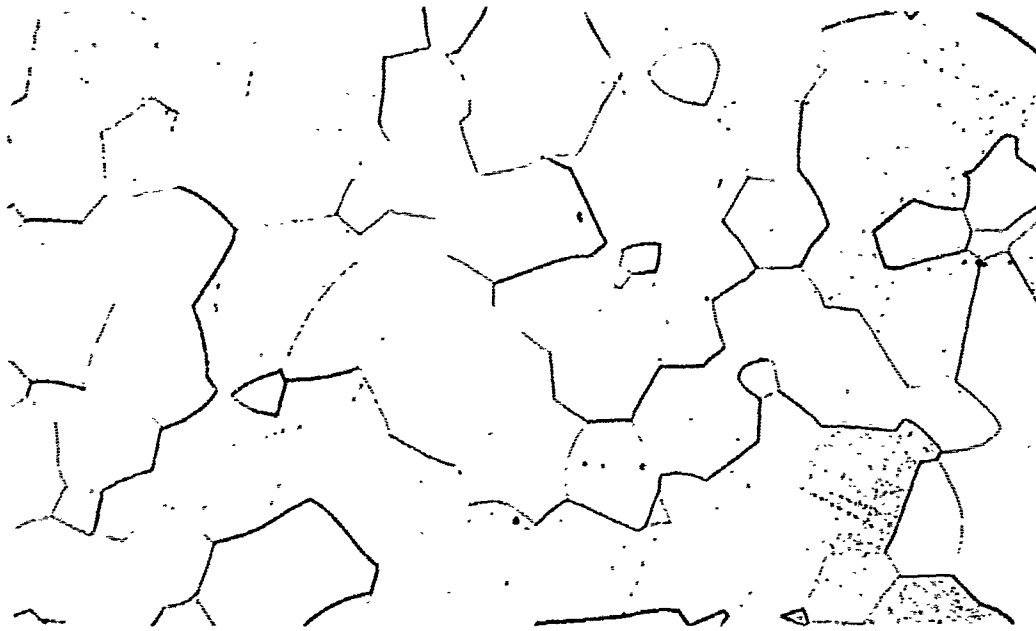

Neg. No. 27033

X200

Fig. 2 - Microstructure of 0.020 in. V-60Cb-1Ti sheet after an 8 hr vacuum heat treatment at 2150° F.

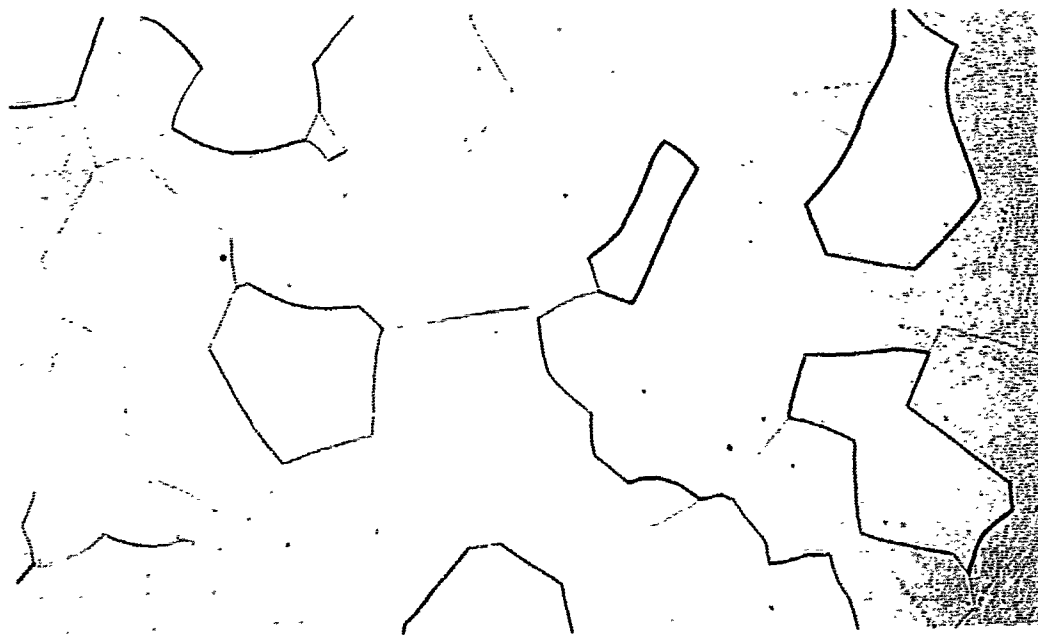

Neg. No. 26843

X200

Fig. 3 - Microstructure of 0.020 in. V-60Cb-1Ti sheet after a standard 8 hr siliconizing treatment.

B. Development of Slurry and Liquid Cementation Type Coatings for 0.020 in. V-60Cb-1Ti Sheet

The purpose of developing an oxidation-protective slurry coating for vanadium-base alloys is twofold. First, it would be advantageous to eliminate the inherent problems of pack siliconizing such as warpage and coating nonuniformity of large or complicated geometries and the prolonged heat treatment that is necessary. Second, it would be practical to develop a "patch" coating for defective pack-siliconized samples--that is, to develop a slurry that could be painted or sprayed over a cracked or defective area of pack siliconized specimens.

Studies were continued to develop a suitable oxidation-resistant coating for the V-60Cb-1Ti alloy which can be applied by painting, spraying, or dipping in a slurry of metal powders, followed by a diffusion heat treatment. The coating runs made during this report period are listed in Table III. The sheet samples, 0.025 x 0.5 x 0.75 in., were grit blasted, pickled in 25HNO_3 - 5HF - $70\text{H}_2\text{O}$, rinsed in acetone, dipped into the slurry composition, air dried, and then heat-treated either in flowing or static argon or vacuum.

The retort used for vacuum treatment was checked for ultimate vacuum and leak rate and was found satisfactory; however, all of the samples including the Inconel support rack appeared partially oxidized when removed from the retort. Since sample AS-23W had a Vickers hardness of 325 DPH, gaseous contamination of the samples was unlikely. This same effect of poor surface appearance has also been noticed when using flowing argon in this retort. This phenomenon is under study at the present time.

Oxidation data for samples coated during this report period are given in Table IV; however, many of the coated samples were not exposed because of this poor visual appearance.

C. Pack-Siliconizing Studies of Other Vanadium-Base Alloys

Promising vanadium-base alloys that are being investigated under Contract NOw 64-0239-c, "Vanadium Alloy Studies" (IITRI Project B6021), are also studied for coatability under this program. The most promising of these alloys, V-40Cb-30Ta-1Ti, has been given further evaluation.

IIT RESEARCH INSTITUTE

TABLE III
SLURRY COATING HEAT TREATMENTS

Coating Run	Slurry Composition	Heat Treatment	
		Time, hr	Temp., °F
<u>Flowing Argon Atmosphere</u>			
AS-22	2.5Si-7.5Cb-25Al-65Sn	2	1800
AS-22S	2.5Si-7.5Cb-25Al-65Sn	2	1800
<u>Vacuum</u>			
AS-23V	2.5Si-7.5Cb-25Al-65Sn	2	1650
AS-23VS	2.5Si-7.5Cb-25Al-65Sn	2	1650
AS-24V	11.5Si-20Al-68Sn	4	1650
AS-24VS	11.5Si-20Al-68Sn	4	1650
AS-25V	2.5Si-7.5Cb-25Al-65Sn	3	1650
AS-25VS	2.5Si-7.5Cb-25Al-65Sn	3	1650
AS-26V	5NaF-10Al-30Si-55Sn	24	1650
AS-27V	2.5Si-7.5Cb-25Al-65Sn	1/2	1650
AS-27VS	2.5Si-7.5Cb-25Al-65Sn	1/2	1650
AS-28V	2.5Si-7.5Cb-25Al-65Sn	2	1650
AS-29V	2.5Si-7.5Cb-25Al-65Sn	1	1650

TABLE IV

OXIDATION RESULTS AT 2200° F FOR SLURRY-COATED
V-60Cb-1Ti SHEET SAMPLES

Sample No.	Failure Time, hr	Thermal Cycles	Remarks
AS-22S-1	3	No failure	Quartz boat
AS-22S-2	>24, <90	2	Alumina boat
AS-22S-3	27	1	High purity Al ₂ O ₃
AS-23VS	3		Quartz boat
AS-24VS	30	1	Quartz boat

Seven sheet specimens, 0.5 x 0.5 x 0.025 in., were coated using the standard IITRI procedure except that the activator, corresponding to a concentration of 2 grams per liter of retort volume, was maintained in a separate container. The microstructure of one of these specimens is shown in Figure 4. The oxidation data from the other six are shown in Table V. Figure 5 shows the microstructure of the coating after twenty-five 1/4-hr cycles at 2200° F. The structure is almost identical to the as-coated condition. Figure 6 shows the microstructure of the coating on sample 4, which was exposed for twenty-five 1-hr cycles at 2200° F. Although visual examination showed no evidence of failure, the photomicrograph of the coating clearly shows the penetration of a crack, filled with oxide, almost completely through the protective silicide layer. On the surface, at this point, is a small hill of oxide which appears as dark gray in the photomicrograph. Figure 7 is a photograph of sample 1 showing the advanced stage of this oxide penetration. The oxide in both cases is light brown in color, and is solid at 2200° F, compared to the oxidation product of the V-60Cb-1Ti which is liquid at this elevated temperature.

A preliminary conclusion is that, under the present coating conditions, the static oxidation life of pack-siliconized V-40Cb-30Ta-1Ti is about 50 hr, and under cyclic conditions less than this time, compared to 500 hr for V-60Cb-1Ti under the same conditions. However, it is very likely that this useful life can be extended appreciably with only minor modifications in coating procedure.

III. FUTURE WORK

Major efforts during the forthcoming period will be divided into five areas: (1) continued evaluation of the effect of the coating and coating process on the substrate material; (2) evaluation of mechanical properties after various high-temperature oxidation exposures; (3) continuation of coating studies for new promising alloys that are developed; (4) continued development of a slurry coating process; and (5) evaluation of pack-siliconized and slurry coating compatibility. Mechanical properties will be determined for coated alloys in the as-coated condition and after selected combined stress-oxidation exposures. Slurry coating development will continue by studying metal coating systems containing Ag, Cu, and Sn as vehicles for

IIT RESEARCH INSTITUTE



Neg. No. 26936 X500

Fig. 4

As-siliconized V-40Cb-30Ta-1Ti.

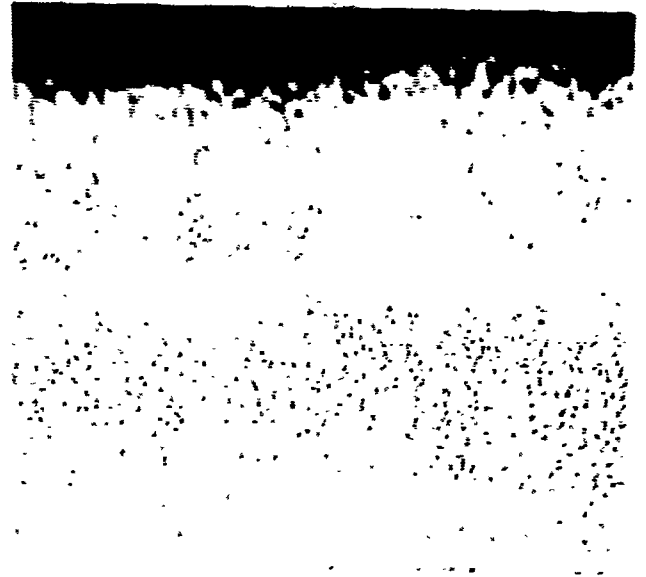

Neg. No. 26947 X500

Fig. 5.

Siliconized V-40Cb-30Ta-1Ti after twenty-five 1/4-hr oxidation cycles at 2200° F.

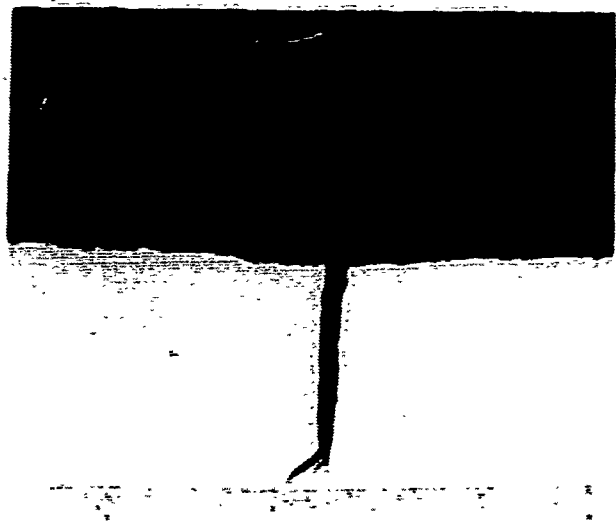

Neg. No. 27068 X250

Fig. 6

Siliconized V-40Cb-30Ta-1Ti after twenty-five 1-hr oxidation cycles at 2200° F.

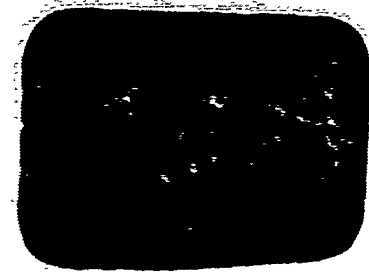

Neg. No. 27100 Fig. 7

Siliconized V-40Cb-30Ta-1Ti coupon after ten 4-hr oxidation cycles at 2200° F.

TABLE V

STATIC OXIDATION TESTS AT 2200° F
ON PACK-SILICONIZED
V-40Cb-30Ta-1Ti SHEET

Sample No.	Number of Cycles	Length per cycle, hr	Remarks
1	10	4	No failure, but crack pattern evident (See Figure 7).
2	6	1/4	No failure (test in progress).
3	25	1/4	No failure (See Figure 5).
4	25	1	No failure (See Figure 6).
5	1	42	Failure started on one side; oxidation product solid at 2200° F.
6	1	61	Failure started on one side.

silicide-type coatings. Also defective pack siliconized specimens will be slurry coated to study the compatibility of these two coating procedures for use as a patch or repair technique.

IV LOGBOOKS AND PERSONNEL

Data for this report are recorded in IITRI Logbook Nos. C14234, C14387, C14700, and C15026.

The following personnel have been the principal contributors to the planning and execution of the work.

F. C. Holtz	Project Consultant
L. I. Kane	Project Engineer
D. D. Lawthers	Project Engineer
J. J. Rausch	Project Supervisor
R. C. Vanderjack	Project Technician

Respectfully submitted,
IIT RESEARCH INSTITUTE

Larry I. Kane,
Assistant Metallurgist

John J. Rausch, Manager
Coatings Research

Approved by:

R. J. Van Thyne, Asst. Director
Metals and Ceramics Research

IIT RESEARCH INSTITUTE

DISTRIBUTION LIST

Contract No. NOW 64-0140-c

Commander
Aeronautical Systems Division
Wright-Patterson Air Force Base
Ohio
Attn: ASRCM-3. Mr. I. Perlmutter

Nuclear Metals Incorporated
Concord, Massachusetts
Attn: Dr. A. Kaufmann

Battelle Memorial Institute
505 King Avenue
Defense Metals Information Center
Columbus 1, Ohio

University of California
Lawrence Radiation Laboratory
Post Office Box 808
Livermore, California
Attn: Mr. Clovis G. Craig
Technical Information Div.

Lockheed Aircraft Corporation
Lockheed Missile Systems Division
Hanover Street
Palo Alto, California
Attn: WDTLA

Commander
Watertown Arsenal
Watertown 72, Massachusetts
Attn: Mr. S. Arnold

Commander
Ordnance Corps
Frankford Arsenal
Pitman Dunn Laboratory
Philadelphia 37, Pennsylvania
Attn: Mr. D. Kleppinger

Chief of Naval Research (ONR:423)
Department of the Navy
Washington 25, D. C.

Director
U. S. Naval Research Laboratory
Metallurgy Division
Washington 25, D. C.
Attn: Mr. W. Pellini

U. S. Atomic Energy Commission
Division of Reactor Development
Engineering Development Branch
Washington 25, D. C.
Attn: Mr. J. M. Simmons
Chief, Metallurgy

Department of the Navy
Bureau of Ships
Washington 25, D. C.
Attn: Code 343

Boeing Airplane Company
Seattle, Washington
Attn: Mr. Cyrus Noritake

Republic Aviation Corporation
Farmingdale, Long Island, N. Y.
Attn: Dr. S. Karman, Chief,
Materials Development
Division

U. S. Atomic Energy Commission
Technical Information Service
Post Office Box 62
Oak Ridge, Tennessee

Commanding Officer
Naval Air Material Center
Aeronautical Materials Laboratory
Philadelphia Naval Base
Philadelphia 12, Pennsylvania

National Aeronautics and Space
Administration
1520 H. Street, N. W.
Washington 25, D. C. (3 copies)

National Academy of Sciences
Materials Advisory Board
2101 Constitution Avenue, N. W.
Washington 25, D. C.
Attn: Dr. Joseph Lane

Oregon Metallurgical Corporation
Post Office Box 484
Albany, Oregon
Attn: Mr. Russell G. Hardy

General Electric Company
Aircraft Nuclear Propulsion Dept.
Cincinnati 15, Ohio
Attn: Mr. James McGurty

National Aeronautics and Space
Administration
Lewis Research Center
21000 Brookpark Road
Cleveland 35, Ohio
Attn: Mr. Charles A. Barrett

Aerojet-General Nucleonics
San Ramon, California
Attn: Mr. Irwin Rhen

E. I. Du Pont de Nemours
and Company, Inc.
Wilmington 98, Delaware
Attn: Mr. J. Symonds
Pigments Department

Crucible Steel Company of
America
Mellon Square
Pittsburgh 22, Pennsylvania
Attn: Mr. Walter L. Finlay

Union Carbide Metals Company
1625 Royal Avenue
Post Office Box 580
Niagra Falls, New York

Battelle Memorial Institute
Columbus 1, Ohio
Attn: M. H. R. Ogden

General Electric Company
Flight Propulsion Laboratory
Cincinnati 15, Ohio
Attn: Mr. R. G. Frank, Manager
Space Metallurgy Projects

Chromalloy Corporation
169 Western Highway
West Nyack, New York
Attn: Mr. Richard L. Wachtell

Harvey Aluminum
Research and Development Division
19200 South Western Avenue
Torrance, California

Haynes Stellite Company
Division of Union Carbide Corp.
Kokomo, Indiana
Attn: Mr. H. F. Kuhns

U. S. Bureau of Mines
Boulder City Metallurgy
Research Laboratory
Boulder City, Nevada
Attn: Dr. D. H. Baker, Jr.

Armed Services Technical
Information Agency
Arlington Hall Station
Arlington 12, Virginia (5 Copies)

Department of the Navy
Bureau of Naval Weapons
Washington 25, D. C.
Attn: Mr. Richard Schmidt
Code RRMA-222

Office of Naval Research
86 East Randolph Street
Chicago 1, Illinois
Attn: Mr. R. Hedlund (3 copies
+ repro)

SYLCOR Division
Sylvania Electric Products Inc.
208-20 Willets Point Blvd.,
Bayside, Long Island, New York
Attn: Mr. L. Sama,
Section Head
Metallurgy Department

National Aeronautics and
Space Administration
Langley Research Center
Langley Station
Hampton, Virginia
Attn: Mr. Charles Manning

McDonnell Aircraft Corporation
Lambert-Saint Louis Municipal
Airport
Post Office Box 516
St. Louis 66, Missouri
Attn: Mr. Howard Siegel
Dept. 272

Bell Aerosystems Company
Division Bell Aerospace Corp.
Buffalo 5, New York
Attn: Mr. E. A. Dalega

North American Aviation, Inc.
Rocketdyne Division
6633 Canoga Avenue
Canoga Park, California
Attn: Mr. R. J. Thompson, Jr.
Director Research

North American Aviation, Inc.
Los Angeles Division
International Airport
Los Angeles 9, California
Attn: Mr. H. H. Crotaley,
Manager, Applied Science

Chance-Vought Corporation
Astronautics Division
Post Office Box 6267
Dallas 22, Texas
Attn: Mr. M. J. Rudick, Manager
Space Technology

Aeronautical Systems Division
Air Force Systems Command
Wright-Patterson Air Force Base
Ohio
Attn: Mr. James J. Mattice
Acting Chief, Coatings Section
Nonmetallic Materials Laboratory
Directorate of Materials and
Processes

U. S. Department of the Interior
Bureau of Mines
Washington 25, D. C.
Attn: Mr. Richard F. Stevens, Jr.

Argonne National Laboratory
9700 South Cass Avenue
Argonne, Illinois
Attn: Mr. Ross Mayfield

Pratt & Whitney Aircraft
East Hartford, Connecticut
Attn: E. Daler,
Materials Development
Laboratory

Scientific and Technical Infor-
mation Facility
Post Office Box 5700
Bethesda, Maryland
Attn: NASA Representative
(SAK/DL-440)

Commanding General
U. S. Army Weapons Command
Attn: AMSWE-RDR
Rock Island, Illinois

Commanding Officer
Watervliet Arsenal
Attn: SWEWV-RDR
Watervliet, New York

Dr. A. F. Weinberg
General Atomics Division
General Dynamics Corporation
San Diego, California

Martin-Marietta Corporation
P. O. 5837 (MP-275)
Orlando, Florida
Attn: B. R. Rajala