

1964

27

20-P

COPY	1	OF	1
HARD COPY	\$ 1.00		
MICROFICHE	\$.050		

6051

AD-605138

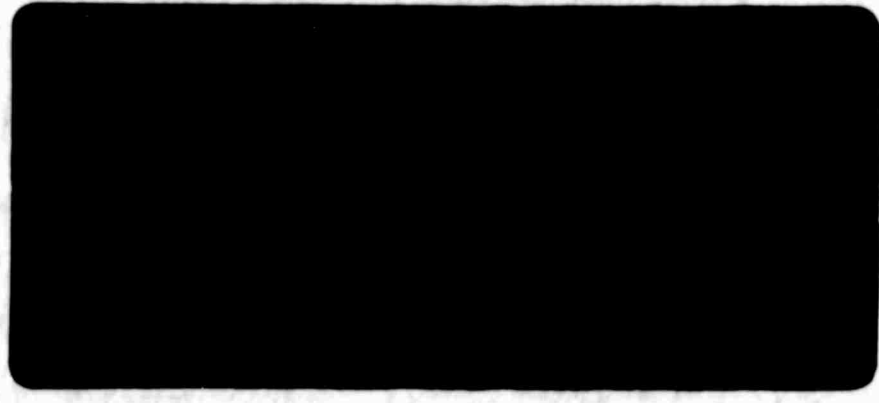

ARDE-PORTLAND, INC.
 100 WEST CENTURY ROAD
 PARAMUS, NEW JERSEY

DDC
REPRODUCED
 AUG 24 1964
DDC-IRA C

02-08-5037

DISCLAIMER NOTICE

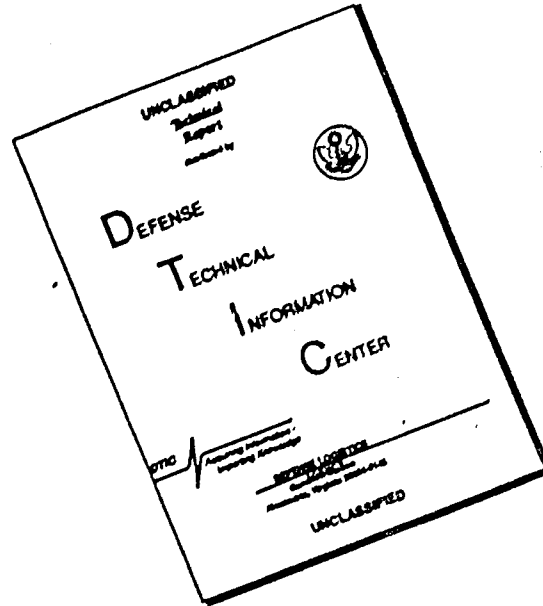

THIS DOCUMENT IS BEST QUALITY AVAILABLE. THE COPY FURNISHED TO DTIC CONTAINED A SIGNIFICANT NUMBER OF PAGES WHICH DO NOT REPRODUCE LEGIBLY.

605138

PROGRESS REPORT NO. 7
Period: December 21, 1960 to January 20, 1961
DEVELOPMENT OF ULTRA-HIGH STRENGTH
ROCKET MOTOR CASES BY CRYOGENIC STRETCH FORMING
AND
COOLED SOLID PROPELLANT ROCKET NOZZLES

Prepared For
United States Army
Contract DA-30-069-ORD-3099

Prepared by: R. H. Cooper

Approved by: J. M. Pearce

4
CONTENTS :

~~1. Introduction~~

2 -> Task A - Cryogenically Stretch Formed Rocket Cases :

~~2.1 Work Accomplished~~

~~2.1.1 Test Results~~

~~2.1.1.1 Vessel Tests ;~~

~~2.1.1.2 Metallurgical Investigation ;~~

~~2.1.2 Materials and Properties Evaluation ;~~

~~2.1.2.1 Strength - New Materials ;~~

~~2.1.2.2 Stress Corrosion ;~~

~~2.2 Work Projected~~

3. Task B - Cooled Solid Propellant Rocket Nozzles :

~~3.1 Work Accomplished~~

~~3.1.1 Mechanical Design ;~~

~~3.1.1.1 Coolant Reservoir ;~~

~~3.1.1.2 Spray Cooled Nozzle ;~~

~~3.1.2 Lithium Flow System Checkout,~~

~~3.1.3 Visit with Rocketdyne Personnel~~

3.2 Work Projected

1. INTRODUCTION

→ This report gives an account of progress on ~~Contract DA-20-060-ORD-2050~~ for the period December 21, 1960 to January 20, 1961. The information is presented in two (2) sections. The first section describes the work performed on Task A, Development of Ultra-High Strength Rocket Cases by Cryogenic Stretch Forming. The second section reports progress on Task B, Cooled Solid Propellant Rocket Nozzles. ↗

REPORT NO. _____

JOB NO. _____

PREPARED BY _____

DATE _____

2. TASK A

DEVELOPMENT OF ULTRA-HIGH STRENGTH

ROCKET MOTOR CASES

BY

CRYOGENIC STRETCH FORMING

CONTRACT DA-30-069-ORD-3099

2.1 Work Accomplished

One cylindrical vessel was tested during this report period. On a concurrent program for the Navy, several vessels were stretch formed in a forming die and these results are reported here, as pertinent to the program.

A revision of the cryogenic program plan was started, based on work done to this point in the program.

Studies of the effect of bosses in the head of a vessel during stretching were begun.

Designs were produced for fabricating vessels with a large port or boss on the hemispherical surface.

The metallurgical investigation of the area in the vicinity of welds was continued.

2.1.1 Test Results

2.1.1.1 Vessel Tests

One vessel was stretch formed in a cylindrical forming die. The objective of the test was to establish the degree of control which could be obtained on the cylindrical portion of the vessel. A high carbon vessel was planned but this was delayed to await additional results from metallurgical investigation.

The vessel was first pressurized to a pressure of 2400 psi at -320°F (equivalent to a true stress of 275,000 psi in a free formed vessel). At this pressure, the vessel was barrel-shaped and the center of the vessel just touched the I.D. of the die. The ends of the cylindrical portion, restrained by the hemispherical heads, were somewhat smaller in diameter. Additional increments of pressure were

applied until a major portion of the vessel conformed to the die. The final pressure applied was 2750 psi. At this stage the vessel was removed from the die for room temperature hydrotest.

The die I.D. was 12.62 inches. The vessel O.D., after spring-back, was 12.50 inches. Measurements of the cylindrical portion of the vessel showed a total variation of .015 inches from this 12.50 figure. Since the original preform dimension was 11.06", this represents a cryogenic diametral strain of 13%.

Hydrotest of this vessel was conducted after a temper at 500°F for 20 hours. This additional treatment was applied on the basis of data presented in Report #6.

Hydrotest results showed failure at a nominal stress of 260,000 psi at room temperature.

During this same period, two additional vessels, with a cylindrical portion 30" long, and with the same diameter as the vessel discussed above, were stretch formed in a die.

These two vessels were fabricated for another program. Figures 2.1 and 2.2 show their dimensions over most of the 30" length of cylinder after stretching. This data demonstrates the dimensional control possible on the cylindrical portion of a vessel.

2.1.1.2 Metallurgical Investigation

Welding - During this period, the metallurgical investigation concentrated on the reasons for apparent loss of properties at -320°F in the vicinity of the weld of the high carbon material.

Micro-photographs are being prepared for presentation in the next report.

A complete summary of the investigation will also be presented at that time.

At present, indications are that two types of failure have been occurring at -320°F . The first type, due to weld restraint in the low carbon material was dealt with in Report #6. The second type, associated with the high carbon materials, at present seems to be due to excessive carbide precipitation in the grain boundaries about extremely large grains formed during the welding of this material.

2.1.2 Materials and Properties Evaluation

2.1.2.1 Strength - New Materials

International Nickel Co. data has recently indicated that the response of cryogenically stretch formed material to post-stretch tempering can be increased by small additions of Cb or Al to the austenitic stainless steels.

Inco work has been performed on more stable varieties of the 300 series of stainless steel. We are attempting therefore, to obtain some heats for tensile testing which will consist of a 301 heat modified with Cb. We anticipate a very high strength material.

2.1.2.2 Stress Corrosion

A visit was made to Frankford Arsenal to discuss the methods for evaluating stress corrosion properties of the stretch formed materials. It was suggested by Frankford that stress corrosion evaluation be performed by contractors already doing work of this nature under technical supervision by Frankford personnel.

Arrangements were made for preliminary investigation of stress corrosion of cryogenically stretch formed 301 to be performed by Mellon Institute

2.2 Work Projected

Next period, completion of the revised program approach is expected.

In addition, a summary, to date, of metallurgical investigation of the welds will be completed.

Additional vessels will be stretched to compare more closely the strains occurring in head and cylinder.

Spheres will be stretched to study head strain independently of cylinder strain and to determine the differences in strengthening effect due to stretching biaxially with a 2:1 biaxiality (cylinder) and a 1:1 biaxiality (spheres).

Approaches to establishing the degree of notch sensitivity of these materials at high strength levels will be planned.

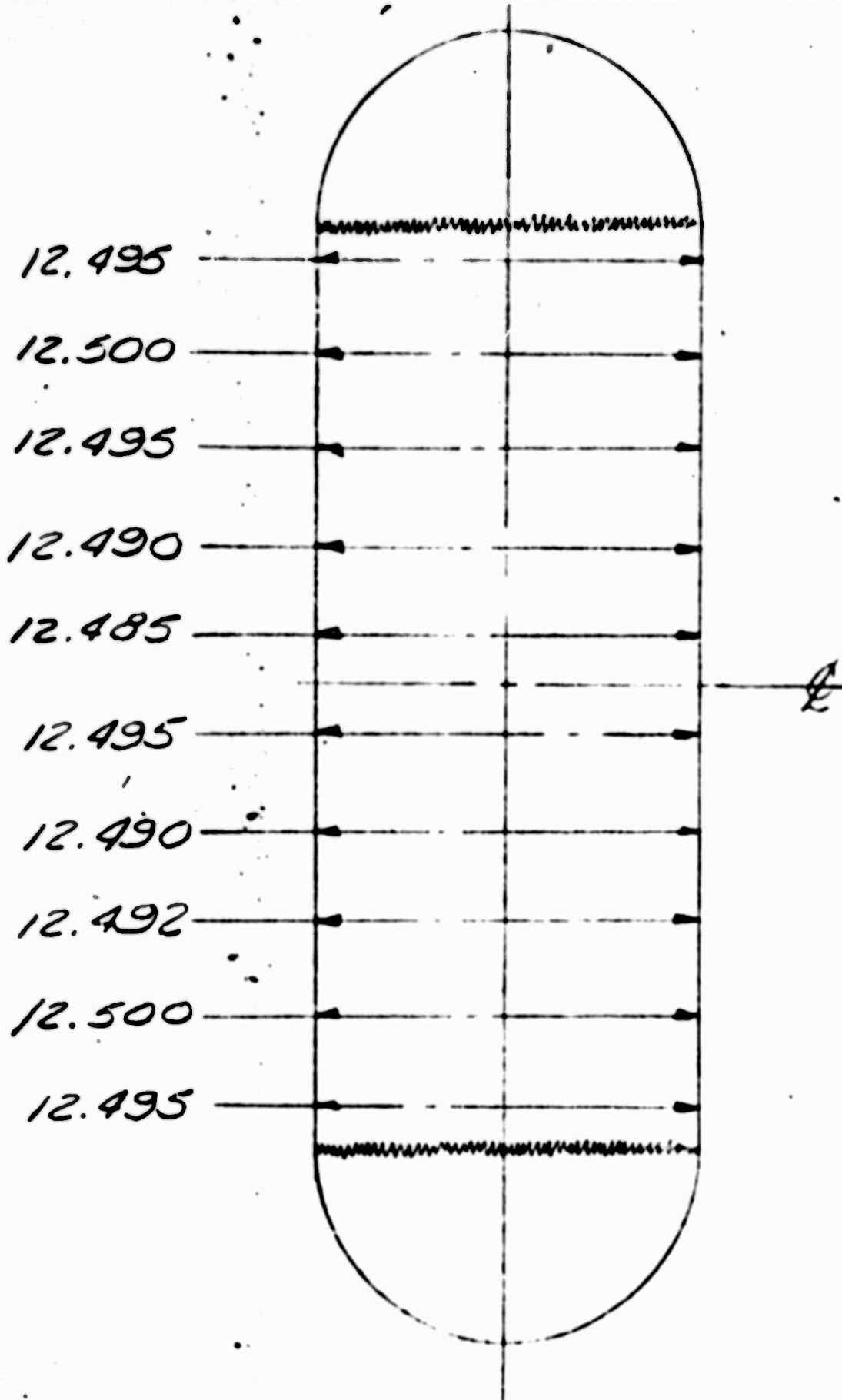

CASE DIMENSIONS AFTER STRETCHING

FIG. 2.1

REPORT NO. _____

JOB NO. _____

PREPARED BY _____

DATE _____

3. TASK B

COOLED SOLID PROPELLANT
ROCKET NOZZLES
CONTRACT DA-30-069-ORD-3099

REPORT NO. _____

JOB NO. _____

PREPARED BY _____

DATE _____

3.1 Work Accomplished

During this reporting period detailed design of an internally spray cooled nozzle was continued.

In addition a detailed design was started on a cold flow rig for the internal spray film cooled nozzle.

A request was made to NASA via OMRO for additional data of the same nature as that already done by that agency on "Heat Conduction in Hollow Cylinders". (See Report #6)

Procurement of lithium flow system components and the cooled nozzle continued during this period.

Arrangements were started at Portland for preparation of a test site for the checkout of the lithium flow system.

The coolant reservoir design, revised for supplemental heating, (as reported in last report) was released to the shop.

3.1.1 Mechanical Design - During this past period design activity concentrated on the internally spray cooled nozzle.

3.1.1.1 Coolant Reservoir

Additional drawings were provided to the shop for fabrication of the coolant reservoir with modified heating provisions. These modifications are shown in Drawings B 1816, E1873, E1888B, E1794C, B101833.

3.1.1.2 Spray Cooled Nozzle

The spray cooled nozzle design, in its present concept, will consist of a lithium injector fabricated of stainless steel.

REPORT NO. _____

JOB NO. _____

PREPARED BY _____

DATE _____

The lithium will be dispersed upon injection through small holes. The spray which results will be directed parallel to the wall. The design objective of the injector is to keep this spray against the wall and prevent it from mixing with the core gases.

The nozzle to be cooled is simply constructed from a molybdenum bar and is mechanically attached to the injector. This approach is presently being detailed.

It is evident that some testing will have to be performed to assure that the spray is not distributed across the core profile. Therefore, a cold flow rig is being designed so that the effect of spray hole pattern on distribution of the coolant may be studied. The rig will utilize heated nitrogen gas in the core, and water as the coolant.

3.1.2 Lithium Flow System Checkout - Preparation of a test site to evaluate the lithium flow system is under way at Portland.

An isolated location has already been selected. The test facility will consist primarily of a steel based platform with a remotely controlled power supply.

Flow controls will also be remotely operated. A blockhouse is already available and will be utilized as a control and observation center. The design of the test platform has started.

3.1.3 Visit with Rocketdyne Personnel - During report period #6, a meeting was arranged by QMRO between Rocketdyne and Arde-Portland to discuss and exchange information on cooled nozzles. A summary of this meeting is presented here.

REPORT NO. _____

JOB NO. _____

PREPARED BY _____

DATE _____

The meeting took place in Washington, D.C. at the ARS convention. Rocketdyne personnel were extremely cooperative and the following are highlights of the discussion:

1. The Rocketdyne approach to nozzle cooling is to cool from the outside of the nozzle with a spray of lithium.
2. There is no duplication of effort between the two programs.
3. Rocketdyne was helpful in presenting data concerning the handling of lithium, as well as heat transfer data which they have obtained.
4. Exchange of progress reports was arranged through OMRO.

3.2 Work Projected

During the next period completion of the design of the spray film cooled nozzle is anticipated. The cold flow rig design will also be completed.

Additional consideration will be given to the instrumentation of the spray film cooled nozzle.

Hardware procurement will continue.

NO. 1	NO. 2	NO. 3	NO. 4	NO. 5	NO. 6	NO. 7	NO. 8	NO. 9	NO. 10	NO. 11	NO. 12	NO. 13	NO. 14	NO. 15	NO. 16	NO. 17	NO. 18	NO. 19	NO. 20	NO. 21	NO. 22	NO. 23	NO. 24	NO. 25	NO. 26	NO. 27	NO. 28	NO. 29	NO. 30	NO. 31	NO. 32	NO. 33	NO. 34	NO. 35	NO. 36	NO. 37	NO. 38	NO. 39	NO. 40	NO. 41	NO. 42	NO. 43	NO. 44	NO. 45	NO. 46	NO. 47	NO. 48	NO. 49	NO. 50
-------	-------	-------	-------	-------	-------	-------	-------	-------	--------	--------	--------	--------	--------	--------	--------	--------	--------	--------	--------	--------	--------	--------	--------	--------	--------	--------	--------	--------	--------	--------	--------	--------	--------	--------	--------	--------	--------	--------	--------	--------	--------	--------	--------	--------	--------	--------	--------	--------	--------

LAND COUNTY
REGISTERED OFFICE
ARDE-PORTLAND
E1879

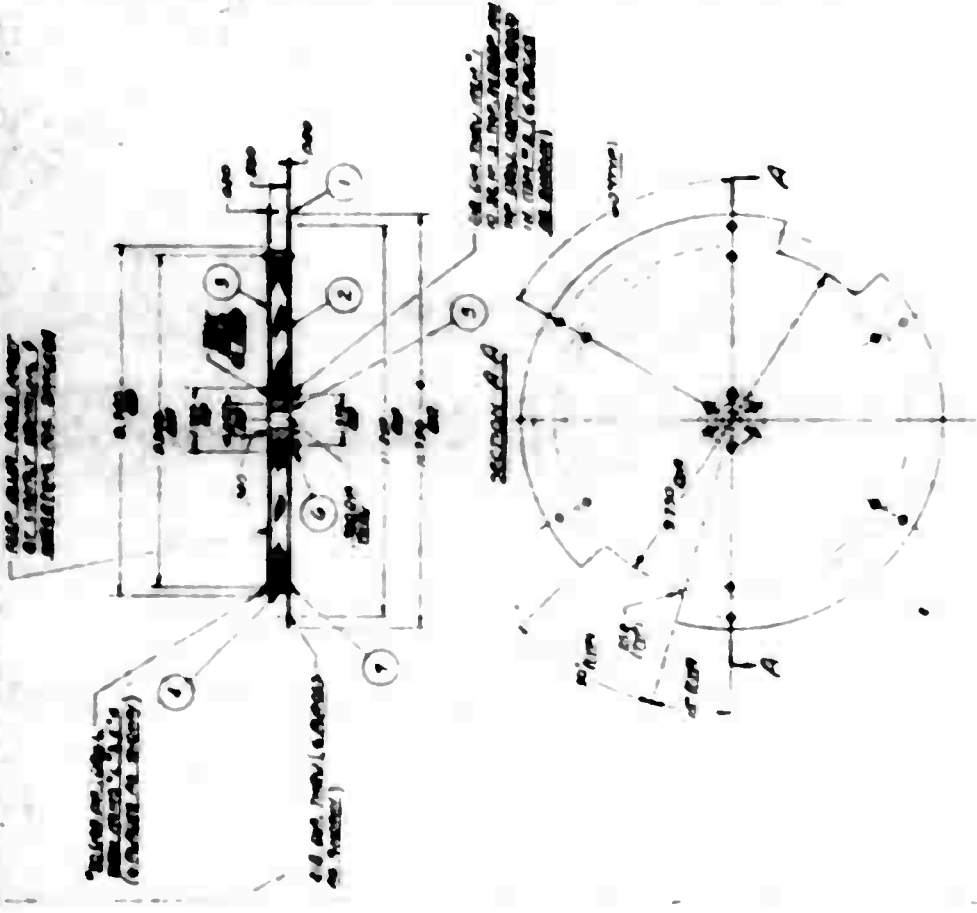

1	2	3	4	5	6	7	8	9	10	11	12	13	14	15	16	17	18	19	20	21	22	23	24	25	26	27	28	29	30	31	32	33	34	35	36	37	38	39	40	41	42	43	44	45	46	47	48	49	50
---	---	---	---	---	---	---	---	---	----	----	----	----	----	----	----	----	----	----	----	----	----	----	----	----	----	----	----	----	----	----	----	----	----	----	----	----	----	----	----	----	----	----	----	----	----	----	----	----	----

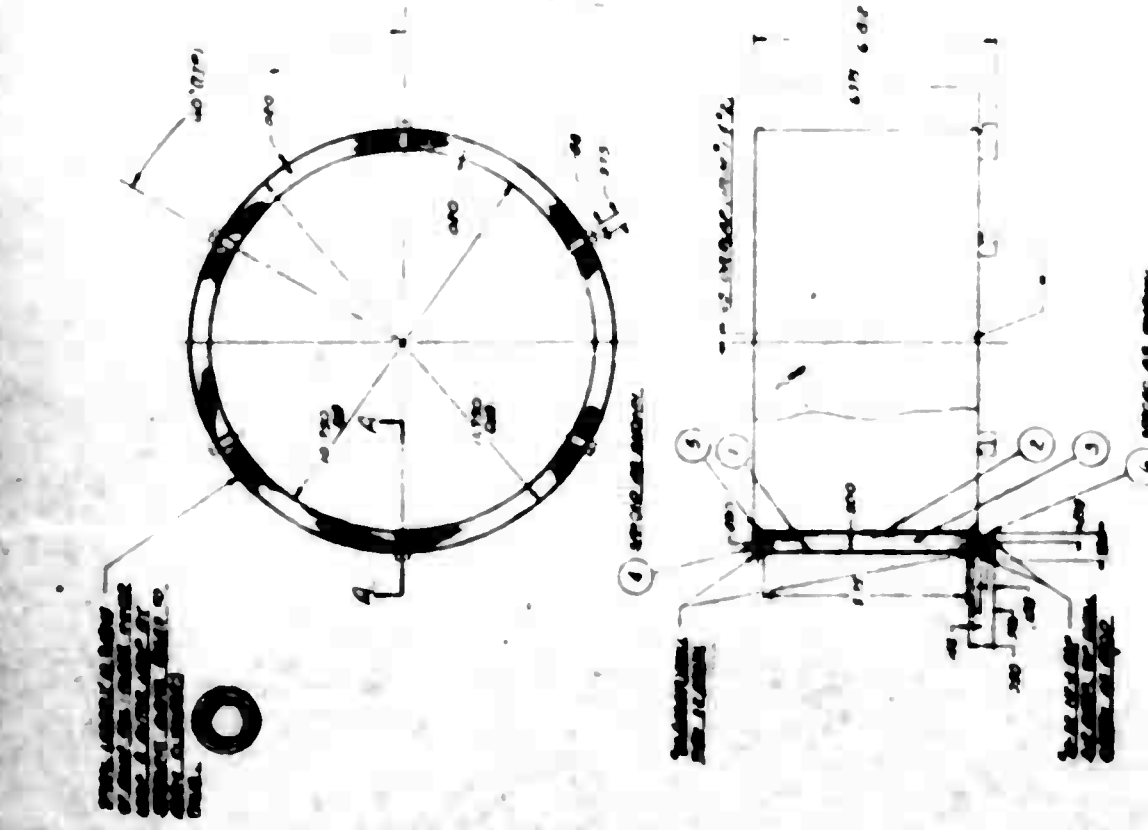

1	2	3	4	5	6	7	8	9	10	11	12	13	14	15	16	17	18	19	20	21	22	23	24	25	26	27	28	29	30	31	32	33	34	35	36	37	38	39	40	41	42	43	44	45	46	47	48	49	50
---	---	---	---	---	---	---	---	---	----	----	----	----	----	----	----	----	----	----	----	----	----	----	----	----	----	----	----	----	----	----	----	----	----	----	----	----	----	----	----	----	----	----	----	----	----	----	----	----	----

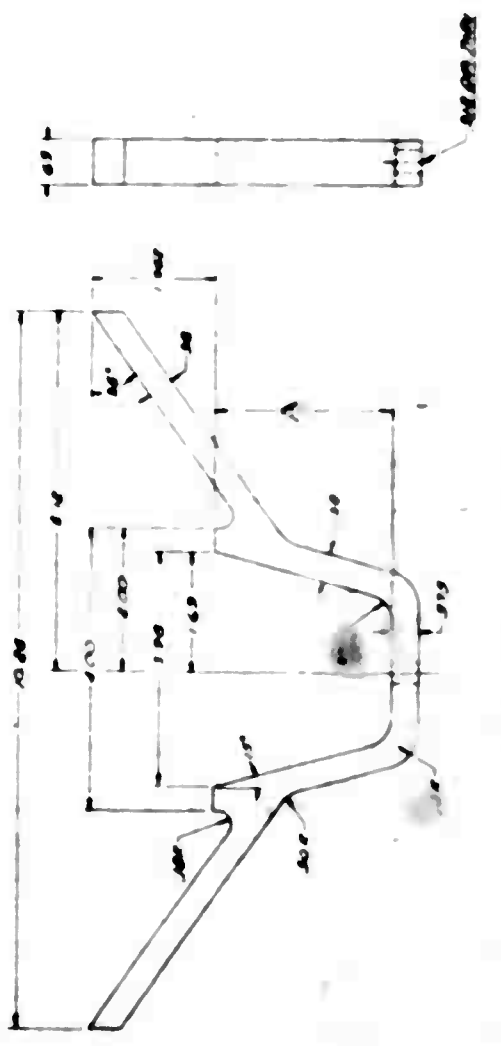

INSULATION ONLY
CONS. NO. E1879

1	2	3	4	5	6	7	8	9	10	11	12	13	14	15	16	17	18	19	20	21	22	23	24	25	26	27	28	29	30	31	32	33	34	35	36	37	38	39	40	41	42	43	44	45	46	47	48	49	50
---	---	---	---	---	---	---	---	---	----	----	----	----	----	----	----	----	----	----	----	----	----	----	----	----	----	----	----	----	----	----	----	----	----	----	----	----	----	----	----	----	----	----	----	----	----	----	----	----	----

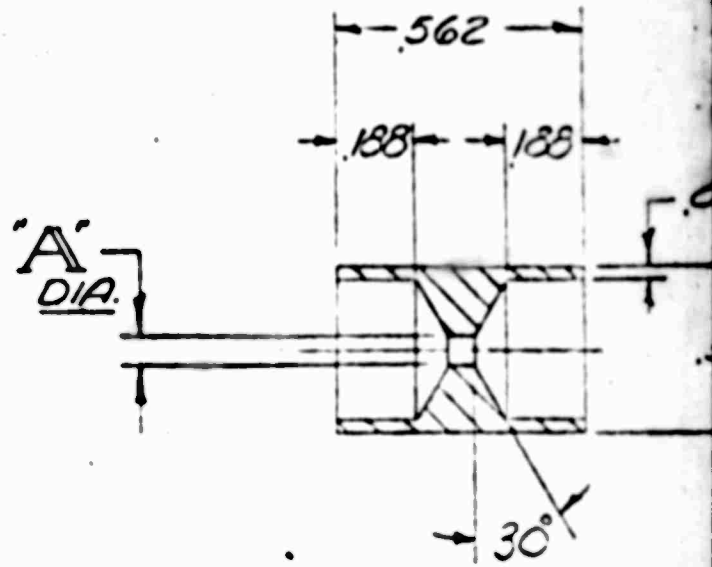
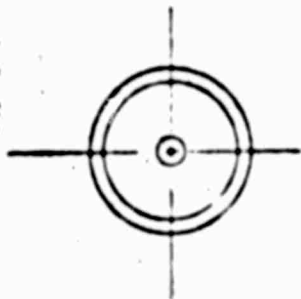

		MATL
		A15
		ST
		HEAT TR
REQ'D	ASS'Y	FINISH
USED ON		UNLES
REF. DWG.		
		ENT.

JOB # 5601

Handwritten signature

B101833
DWG. NO.

CHG.	DESCRIPTION	BY	DATE
------	-------------	----	------

B101833-1	.062
B101833	BLANK
PART NO	A ^{10.32} DIA.

20-7
5-22
SPECIFIED
GHT
QUAL

TITLE <u>RESTRICTOR</u>					
	NAME	DATE		NAME	DATE
DRAWN	DE MERBLE	1-7-61	STRESS ENGR.		
CHE'D	RD	1-10-61	HEAT TREAT ENGR.		
DES. ENG.	TRD	1-10-61	PROJ. ENGR.	W.H. Hall	1/11/61
NEWARK, N.J.					
ARDE-PORTLAND					
SOUTH PORTLAND, ME.					

READ ALL NOTES		
TOLERANCES UNLESS OTHERWISE SPECIFIED		
HUNDS <u>±.02</u>	ANGLES FRACT. <u>31°</u>	TROUS <u>±.010</u>
<p>NOTICE</p> <p>THE ENGINEER HEREBY CERTAINS AND WARRANTS IN THESE DRAWINGS THAT THE DIMENSIONS AND TOLERANCES SPECIFIED THEREIN ARE CORRECT AND COMPLETE AND THAT THE DIMENSIONS AND TOLERANCES SPECIFIED THEREIN ARE THE ONLY DIMENSIONS AND TOLERANCES TO BE USED IN THE FABRICATION OF THE PARTS SHOWN THEREON AND THAT THE DIMENSIONS AND TOLERANCES SPECIFIED THEREIN ARE THE ONLY DIMENSIONS AND TOLERANCES TO BE USED IN THE FABRICATION OF THE PARTS SHOWN THEREON.</p>		
SCALE <u>2 X SIZE</u>		
DWG. NO. <u>B101833</u>		

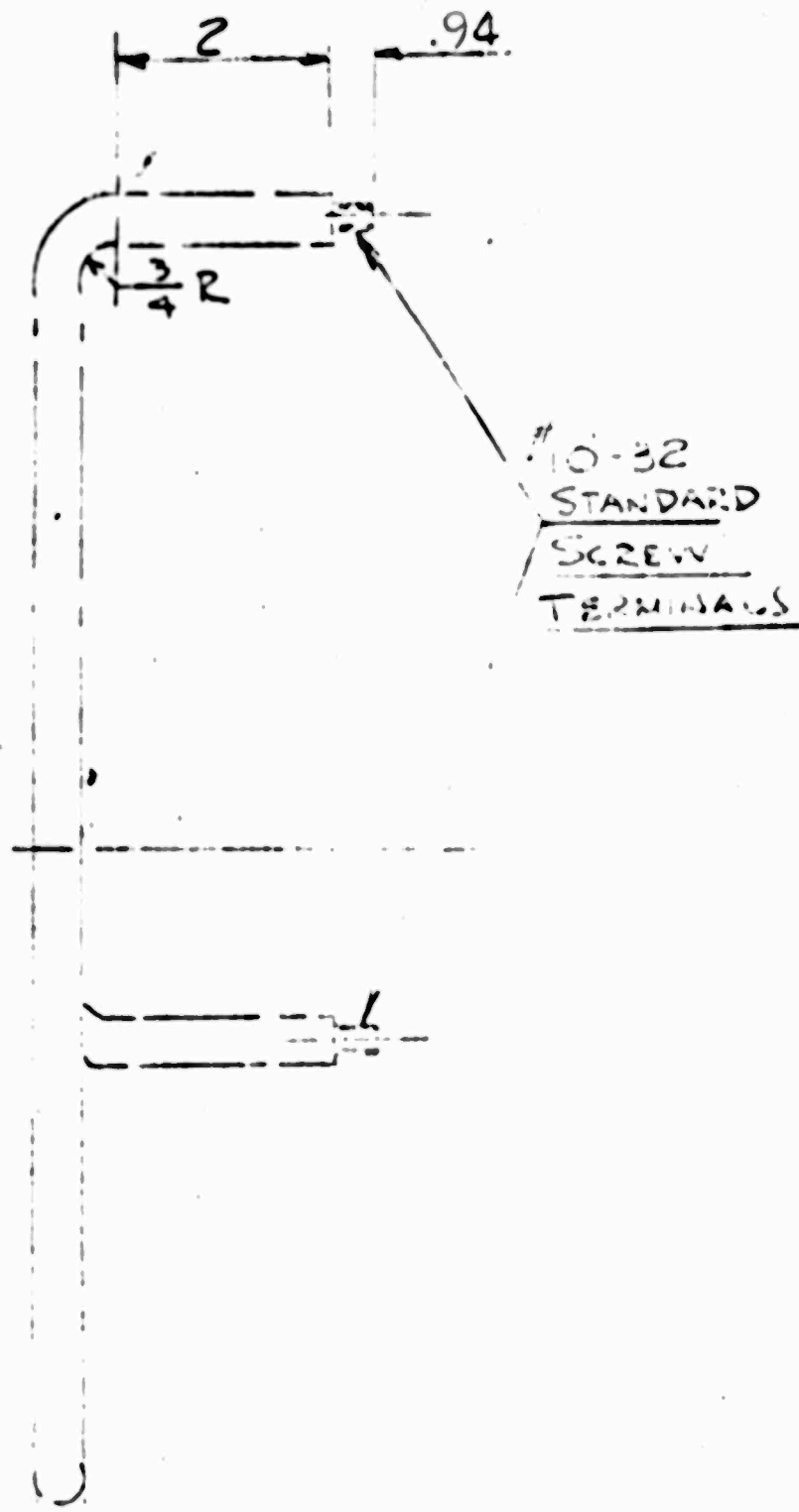

HEATER SPECIFICATION
 2500 WATTS - 240 VOLTS
 APPR. 6 SPIRAL COILS
CIRCUMFERENTIAL ORIENTATION OF
TERMINALS MAY VARY
COILS MUST BE CAPABLE OF
BEING DEFORMED TO 6.12R
HEMISPHERE WITHOUT MALFUNCTION
OR STRUCTURAL FAILURE.

R-11-61
 1-11-61

		MATL
		HEAT TR
REQ'D	ASS'Y	FINISH
USED ON		UNLESS
REF. DWG.		
		EST

91819

DWG. NO.

ENG.

DESIGNED BY

DATE

7-1

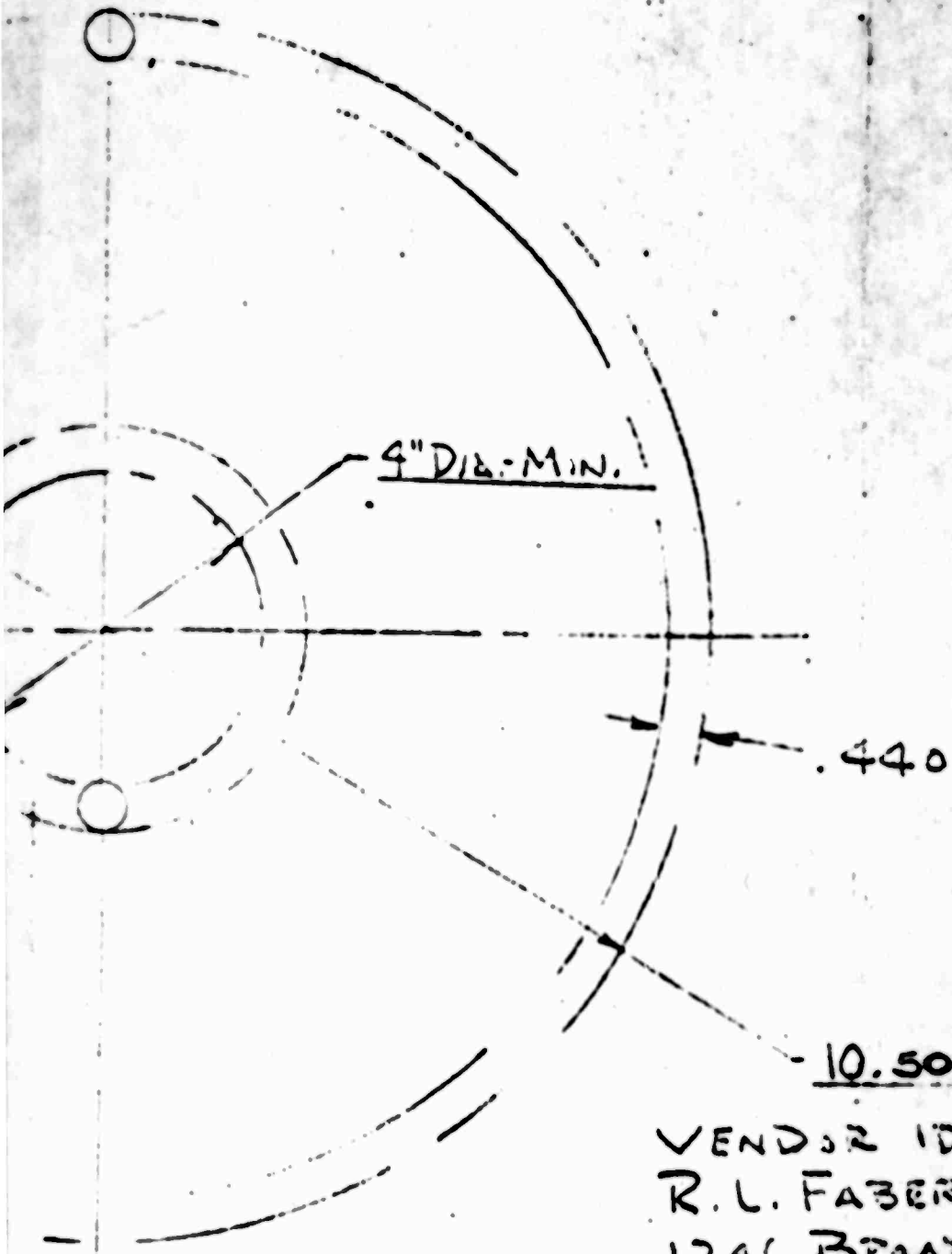

VENDOR IDENTIFICATION - PT TRI-106 XX
 R. L. FABER & ASSOCIATES, INC.
 1246 BEAD ST., BLOOMFIELD, N. J.
 PHONE - EDISON 8-6900

TITLE		NAME		DATE	
HEATER COIL-RESEVOIR					
DRAWN	RD	11-14-61	STRESS ENGR.		
CHK'D	RD	1-14-61	HEAT TRNSFR ENGR.		
DES. ENG.	RD	1-16-61	PROJ. ENGR.	W. H. W.	1/16/61

READ ALL NOTES		
TOLERANCES UNLESS OTHERWISE SPECIFIED		
DIMENSIONS	ANGLES	THOUS
±.02	FRACT.	
<small>THE ENGINEER ASSUMES NO LIABILITY FOR THE DESIGN OR CONSTRUCTION OF THIS EQUIPMENT UNLESS IT IS SPECIFICALLY STATED OTHERWISE IN THE CONTRACT DOCUMENTS.</small>		
<small>SCALE: AS SHOWN</small>		
DATE		ENG.
1-16-61		

NEWARK, N.J.

ARDE-PORTLAND

SOUTH PORTLAND, ME.

UNLESS OTHERWISE SPECIFIED

WEIGHT

ACTUAL