

R-64-438

(FINAL REPORT)

ORGANIZATIONAL MODELS FOR COMMAND POST INFORMATION SYSTEMS

TECHNICAL DOCUMENTARY REPORT NO. ESD-TDR-64-438

JUNE 1964

ESTI PROCESSED

DDC TAB PROJ OFFICER

ACCESSION MASTER FILE

DATE _____

ESTI CONTROL NR AL#-41775

CY NR 1 OF 1 CYS

DIRECTORATE OF COMPUTERS
ELECTRONIC SYSTEMS DIVISION
AIR FORCE SYSTEMS COMMAND
UNITED STATES AIR FORCE
L. G. Hanscom Field, Bedford, Massachusetts

ESD RECORD COPY

RETURN TO
SCIENTIFIC & TECHNICAL INFORMATION DIVISION
(ESTI), BUILDING 1211

COPY NR. _____ OF _____ COPIES

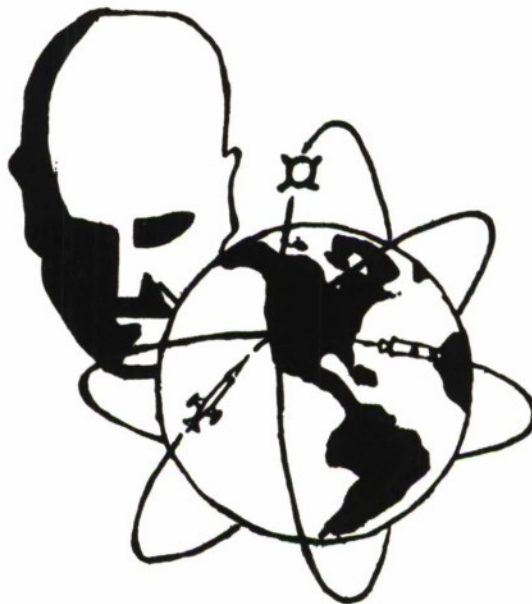

Project 2801

(Prepared under Contract No. AF 19 (628)-2960 by Aircraft Armaments Incorporated,
Cockeysville, Maryland.)

AD603969

When US Government drawings, specifications or other data are used for any purpose other than a definitely related government procurement operation, the government thereby incurs no responsibility nor any obligation whatsoever; and the fact that the government may have formulated, furnished, or in any way supplied the said drawings, specifications, or other data is not to be regarded by implication or otherwise as in any manner licensing the holder or any other person or conveying any rights or permission to manufacture, use, or sell any patented invention that may in any way be related thereto.

Do not return this copy. Retain or destroy.

DDC AVAILABILITY NOTICES

Qualified requesters may obtain copies from Defense Documentation Center (DDC). Orders will be expedited if placed through the librarian or other person designated to request documents from DDC.

Copies available at Office of Technical Services, Department of Commerce.

ORGANIZATIONAL MODELS FOR COMMAND POST INFORMATION SYSTEMS

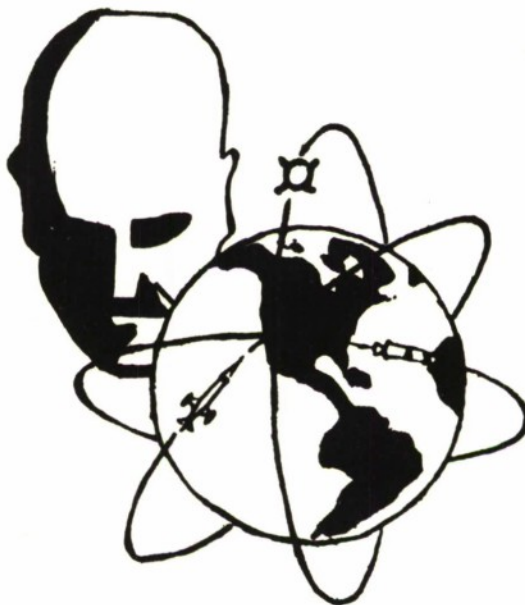

ORGANIZATIONAL MODELS FOR COMMAND POST INFORMATION SYSTEMS

ABSTRACT

This report attempts to clarify issues concerning the organization and functions of command post information systems (CPIS). The purpose of the report is to provide system designers with a better understanding of factors which influence the operation of a CPIS and which constrain system design alternatives. A CPIS is viewed as one of four systems making up a command post -- the others being a command system, a weapon system, and a support system. The Air Force organization is discussed in the light of this concept, with special emphasis being placed on the relationship of the Air Force to the Unified Commands and the "L" systems. The insights gained from this analysis are incorporated into a conceptual model. This model provides the system designer with a conceptual framework for designing an integrated CPIS. An evaluation model, permitting the system designer to test certain design alternatives has been suggested as an extension of the conceptual model. It is felt that application of these models by a system designer will greatly facilitate the design of a CPIS.

REVIEW AND APPROVAL.

This technical documentary report has been reviewed and is approved.

ROBERT P. SAVOY
Project Monitor

KEY WORD LIST

1. COMMAND & CONTROL SYSTEMS
2. COMMUNICATION SYSTEMS
3. ANALYSIS
4. DESIGN
5. MODELS
6. DECISION MAKING
7. BEHAVIOR
8. DATA PROCESSING SYSTEMS

TABLE OF CONTENTS

Section		Page No.
1.0	INTRODUCTION	1
2.0	DESCRIPTIVE MODEL OF A COMMAND POST	9
3.0	THE AIR FORCE ORGANIZATION	20
4.0	CONCEPTUAL MODEL OF A CPIS	29
5.0	CPIS DESIGN EVALUATION MODEL	39

FOREWORD

This report (AAI ER-3547) is the result of work completed on contract number AF 19(628)-2960. During the twelve-month contract period, we were to develop military organization models which could be used in the design of automated aids for command post information systems (CPIS). To accomplish this purpose we: (a) reviewed articles and papers pertaining to command post information systems, command-control systems, and decision theory; and (b) attempted to correlate evolutionary changes in the structure of command posts with changes in technology.

Our literature review led us to two conclusions: (a) there has been a great deal written on subjects pertaining to CPIS design within the past ten years, and (b) most of this literature is general in nature so that direct application to system design is extremely difficult.

Our attempt to correlate evolutionary changes in the structure of command posts with changes in technology produced some interesting findings. The command post selected for study was what is now an Air Defense Nike-Hercules Battery. This command post's predecessor was the Anti-Aircraft Battery, which was established from the old Coast Artillery.

A great many changes in structure and technology occurred during this evolution. In examining the Table of Organization and Equipment (TOE's) for Nike-Hercules Batteries over several years, we found: (a) the organization structure changed, with no apparent change in equipment; and (b) new equipments were incorporated without any apparent changes in organization structure. In other words, no consistent trends could be determined. Possibly, a more detailed study might have shown that informal changes in organization were accomplished before they were formally recognized in the TOE. However, it should be realized that changes in equipment are not the only, and perhaps not the prime, reasons for changing organization structure. Even at the battery level, political and social forces act to influence the organization structure.

Once the influence of such intervening factors was recognized, it was also apparent that the system designer could benefit from a consideration of such factors in the design of CPIS. If the configuration of the CPIS and the choice of component elements were geared to the political and social forces governing the structure of the military organization which would ultimately operate the CPIS, then the stresses of military accommodation to advanced technological innovations could be minimized. This proposition provided the basic orientation for the continued conduct of the study. Our goal has been to provide the system designer with a set of conceptual tools which would make a direct contribution to the technology of command post information system design.

1.0 INTRODUCTION

1.1.0 Purpose

This report discusses the concept of command post information systems (CPIS). The purpose of the discussion is to provide system designers with an improved insight into the characteristics of military command post information systems, so that certain chronic problems which center on the organizational structure and configuration of information processing functions can more readily be solved. The discussion concerns the interrelationships between the equipment facilities which are utilized by military command post information systems, the operations which such systems are called upon to conduct, and the way in which the military organizations which run such systems are structured.

The discussion is based on an analysis of information processing functions as they occur throughout a command post. This cluster of widely distributed and varied functions is treated as a distinct conceptual entity and given the label, Command Post Information System, or CPIS. The separation of information processing functions from other functions within the command post permits the identification of problems and the recognition of useful solution alternatives which are not usually salient in the conventional command post information design process.

One of the reasons why the point of view espoused in the present report is not ordinarily available to the designer is the way in which the design chore is divided between members of the design team. Assignments are usually made along subsystem lines such that different people are assigned responsibility for sensors, data processors, displays, and personnel subsystems as distinct tasks. Below the level of project supervision, no single person or group is likely to be responsible for all information processing functions, as such. System integration tends to be postponed under such an arrangement and, when it takes place, may require a series of compromises which do not contribute to system effectiveness, having been based in part on non-relevant criteria.

The content of the present report is intended to provide a central meeting ground for each of the specialist groups that contributes to command system design. These groups with their divergent talents, knowledge, vocabularies, and points of view, need a common conceptual framework whereby they can begin to integrate their unique abilities in a mutual effort to solve the problems of overall system design. The present report is an attempt to provide such a framework.

1.2.0 Background

1.2.1 Historical Perspective

Since the beginnings of recorded history, military commanders have had reason to complain about the quantity and quality of the information provided them as they considered critical strategic and tactical decisions. In spite of the slow pace of events, information about the enemy and even about one's own forces tended to be unreliable. In part, this was due to the necessary reliance on fallible humans for the observation of events, and the transmission and summarization of such observations. It was also due to the prevalent tendency of command to seek military advantage by extending operations to the limits of available communications technology.

In spite of operational deficiencies, however, the need for a self-conscious approach to the design of CPIS was not apparent until after World War II. Prior to that time, the equipment technology available for utilization in CPIS was not particularly complex. The ordinary commander in the field had no difficulty in comprehending exactly what capabilities were available for his use. Facilities were sufficiently simple that their configuration could be adjusted on the spot, if need be, to accommodate to a particular situation or the personal biases of the commander. In effect, the commander was given the raw materials of a CPIS in the form of men and equipment and literally configured his own CPIS.

Today, the situation is far different. Weaponry, electronic technology and, as a result, the conditions of battle, have all undergone revolutionary change. From the point of view of the military commander, the conditions of battle require a sophisticated CPIS facility, not just to overcome the fallibility of observers and communicators that has always existed, but to compensate for the amplification of the scope of battle. Some of the more prominent features of the modern military environment which have helped create the need for elaborate CPIS facilities are as follows:

1. Similar kinds of events may occur within the same narrow time frame at highly dispersed locations.
2. The distances between the location of an event and the location of the military decision-maker are likely to be large.
3. Many different kinds of events are likely to be significant to a single military operation or even to a single decision.
4. Some important events may not be detectable or interpretable without the use of special sensors.

5. Event occurrence is uncertain with respect to time and place.
6. The rate of event occurrence is uneven and may often exceed the acceptance capabilities of a single person.
7. For many types of events, a single occurrence is not significant -- only the advent of a series or cluster of events is relevant.
8. In those instances where serial pattern is critical, it is quite likely that the complexity, duration, or length of the series may exceed the retentive capacity of a single decision-maker.

In recent years, many people have thought that some of the technologies which have caused the increase in complexity of the military environment could be employed to reduce it. An intriguing example is provided by the book, "War - 1974," written by Lt. Col. Robert B. Rigg, in which he describes his concept of a futuristic command post information system in the following fashion:

"When the three men entered the van, the tall congressman was amazed at the crowded and conglomerate electronics the vehicle held. Along one wall were 44 twelve-inch TV picture screens, plus several radios. Mounted on the far end of the interior wall were nine 24-inch TV screens plus one 54-inch master TV screen.

'My god, where's the bar?' muttered the short congressman. Mounted on the other wall was a large plastic relief map of Central Asia.

'No grease pencils or acetate on this map?' remarked the tall congressman. 'You've got the strangest military map I ever saw. In fact, you haven't got a line on your map. General, I would say your situation is a blank one.'

'Roger! We thought you'd like to see how secret we can be!'

Suddenly, the relief map lit up like a Christmas tree as a maze of tiny colored lights; underneath the map showed up lines and symbols.

'Wonderful! How does it work?'

A staff major demonstrated.

'You see, there is an electronic screen underneath the map. It is made up of millions of tiny electronic dots smaller than pinheads. They light up and make the small colored symbols. Each tiny dot is prismatic and projects one of eight colors.'

'So your job, major, is to sit here and press buttons on this panel, and make the symbols show up on the map, as I used to do with a grease crayon when I was a captain.'

The major stiffened. He was obviously irked at the senator's ignorance of the map and his relation to it.

'No sir, I mainly read and interpret this map. In fact, you see that symbol change place? Well, that represents the 6th Cavalry group, and it, the unit I mean, moved the symbol automatically.'

'You mean to say, major, that when your subordinate units move, they automatically move symbols on your map?'

'Yes sir, the battle group commander, or division commander, has only to press a button upon arrival at a new location and we have it spotted. Actually, of course, a staff officer does it. He selects the map coordinate for the units' center of mass. He checks the position carefully, inserts the correct numbers into the automatic-map transmission system, and bang, we see a light go off in one place and pop up in another. In the case of a unit moving at night, there will be a change on the map every 20 minutes if such a change is necessary.'

'How about all that red stuff. Does the enemy report in too?'

The major was annoyed by the sarcasm, but he saw the congressman smile.

'No, but our electronic intelligence centers send their respective sector reports in automatically. You see, they are called OWL reports. After filtering, these reports are fed into automatic data-processing machines,

and so density patterns, discriminating patterns, and so forth, are determined. Then, the G2 centers, using enlarged sections of this map, translate the data into appropriate colors and locations. See those orange dots. These are Russian armored units. See the dots in magenta; those are short-range missile units. The purple dots indicate long-range rockets and missile outfits. It takes, we estimate, about a thousand OWL's to produce just one dot on this map and it is a complicated process, but a quick one, due to these automatic data-processing machines.'

'Major, I am amazed, I never appreciated that our military had progressed this far. I hope some day to be on a military committee. As it is, I am on the appropriation committee. Well, I still say, where is the bar?''

This is one military man's notion of how electronic technology could be used in an ideal command post information system. Basically, the CPIS would automatically provide the commanding officer with information about all events which were occurring in the battle area. This notion is based on the premise that if a commander has a complete, real-time description of "the situation," he will make effective decisions.

Such a proposition is too simple to be regarded as an overriding principle of system design. Many considerations will influence the design of an effective CPIS, besides technological capabilities and limitations. Some of these are discussed in the following sections.

1.2.2 System Design Task

Theoretically, the development of a new system is initiated in response to a national policy which results in a military need. This need is first formulated by field commanders who have been assigned the task of implementing the national policy. These field commanders file a request with higher commanders for increased capability. Administrative action then refines the need statement and an elaborate set of technical requirements is formulated. These requirements are supposed to be the means by which the problem is defined for the design engineer.

Although some system requirements undoubtedly follow this evolutionary pattern, other patterns are more typical. In the not too distant past, new technologies seemed to create their own requirements. New and more sophisticated mousetraps created military requirements for new mousetraps. Although this procedure has apparently been abandoned in actual practice, it may return to plague the system designer. More typically today, requirements are generated by special military groups. The field commander,

who must use the ultimate product of system development, may be outside the requirement formulation cycle. Thus, the system designer is presented with a set of requirements which were generated by a group of specialists who are knowledgeable with respect to the so-called big picture, but the system is evaluated by field commanders who had little to do with the requirement formulation. In the end, an engineering masterpiece may be an operational flop because the conditions of field utilization were not adequately considered.

Another factor coloring the design task is the stereotyped image of the military commander held by technically trained system designers. Part of the system designer's folklore is that the commander is unable to effectively utilize the results of technology because of his lack of a technical education. It is sometimes asserted that the commander is only vaguely aware of the technical resources which could be available to him. Furthermore, he is seen as being unable to translate his operational needs into terms which are compatible with the concepts and principles of system engineering. Evaluations conducted in the field are often interpreted as being trivial or unrealistic. In the face of these presumably trivial or impossible inputs, the system designer is tempted to assume a condescending attitude and determines to give the user "what he really needs" -- rather than what he wants. The determination of what the user "really" needs may be based solely on technical considerations related to the formal mission of the command post.

For better or worse, however, requirements get established with varying degrees of influence from the user, and with varying levels of concern with the ultimate environment in which the system will operate. The translation of requirements into a design follows a reasonably consistent pattern.

When a System Project Office is established to design a military system, it usually adopts the standard "systems" approach. This approach consists of:

1. Defining the missions that the system is supposed to accomplish.
2. Deriving the functions that must be performed to accomplish the missions.
3. Allocating the functions to different subsystem components, such as men, computers, sensors, etc.
4. Specifying performance requirements for each of the subsystem components, bearing in mind interface requirements, state-of-the-art and potential technological breakthroughs.

This sequence of activities is often supported by the formulation of an operational model of the system. This model typically includes a gross categorization of the functions which the system must perform to accomplish its military mission. Such a model is used to facilitate communication between team members and reduce the problems of system integration.

As a nucleus for system design activities, the model suffers from certain limitations. Of necessity, such models are abstract and tend to present an over-simplified picture of the system. Furthermore, the model is only as good as the assumptions upon which it is based. These assumptions will reflect technical prejudices as suggested above. If the assumptions do not include a consideration of military organizational and utilization factors, the design is likely to be deficient; not in a technical sense of being inoperative, but in a functional sense of being only partly compatible with the objectives of the user organization. The present report should contribute to the inclusion of organizational and utilization factors in the formulation of a system model.

1.2.3 Constraints

The designer never has free latitude in his selection of design alternatives. Some sources of constraints are: (a) national policies; (b) military strategy, traditions and established procedures; (c) technological fads and fashions; and (d) the economics of system development.

These constraints do not operate in any very simple or straightforward manner. For instance, advances in our military capability will influence the national policy adopted by State Department officials and others in much the same way as changes in enemy technology do. Moreover, the relationship between what is feasible by way of capabilities and what is desirable by way of incorporation into the system is less clear with time. For example, it has become feasible to consider the use of computers to make fine discriminations between electronically detected signals. Such use might not be desirable though, from the standpoint of susceptibility to intentional jamming by an intelligent enemy. Yet, such negative considerations conflict with the current vogue of employing computers to the utmost in military operations.

Military strategy determines the basic nature of the GPIS. For example, in strategic air war defensive fighting is done with missiles fired from the ground or from defensive fighter planes operating on, over, or near home or friendly territories. Offensive fighting, on the other hand, is done by bombers releasing bombs over targets in enemy territory, which may be on the other side of the world, and by long-range missiles directed against the same targets. The adoption of a strategy which is biased in favor of either a defensive or offensive posture will affect the type of forces needed to implement the strategy, and the information required to control these forces. The disposition of the military toward either strategy

will be substantially affected by political considerations. This follows from Clausewitz's dictum that the existence and use of military force is merely one of the means to attain political goals. Thus, national policy and changes in national policy resulting from other than military considerations will influence the design of at least some CPIS.

The designer, then, is someone who is given an engineering task in which his options are constrained in certain respects and ill-defined in others. Although we do not intend to dwell upon these constraints to any extent in this report, we feel that the designer needs to understand just what range of options exist before he can begin his job.

1.3.0 Summary

In summary, it may be concluded that the absolute necessity for effective CPIS design is a relatively recent requirement brought about by technological developments. There are several factors outside the control of the system designer which influence his task. To some extent, there are factors that the engineer must "design around." They include: (a) national and military policy factors; (b) technological factors -- both as they influence the military environment and as they influence potential CPIS functional capability; and (c) social-psychological factors.

The system designer cannot design an effective CPIS by focusing his attention solely on technical matters. He must be aware of other influences on the operation of the CPIS and upon his task. His concept of the CPIS should be sufficiently broad that he can take some of these influences into account in designing a CPIS. This report is intended to provide such a background.

2.0 DESCRIPTIVE MODEL OF A COMMAND POST

2.1.0 Structure and Function

A command post may be viewed as a military organization which contains four functional systems: a command system, an information system, a weapon system, and a support system. By definition, a command post is an organization which is responsible for allocating weapons during the conduct of a battle. Therefore, it must have a command system to allocate the weapons, an information system to supply the information needed to effectively allocate the weapons, a weapon system to allocate, and a system which provides for the maintenance and support of the other three systems.

The command system is reflected to some extent in an organization chart showing the formal structure of the command post. This structure follows a line-staff configuration at all command echelons. The commander at the upper echelon delegates some of his responsibilities and authority to subordinate line commanders. These commanders, in turn, delegate some of their responsibilities and authority to their line commanders. This chain of command defines formal communication channels between line commanders. In addition to delegating responsibilities and authority to subordinate line commanders, a commander also sanctions some degree of authority for his staff. This authority is typically restricted to the technical area which is the staff officer's specialty, such as logistics, communication, personnel, etc.

The primary function of the command system, composed of line commanders and staff officers, is to allocate the resources available to the command post in such a way as to maximize the probability of achieving the missions of the command post. To make these decisions, people in the command system require information. This information is supplied by the command post information system.

The position of a CPIS in the line-staff organization structure is somewhat anomalous. Some information is gathered and processed by staff support facilities. Other information is gathered and processed under the direct supervision of the commander. Still other information is gathered and processed by direct order of the commander, but under the supervision of a staff officer. In other words, the CPIS is distributed throughout the command post in a number of discrete units. The term CPIS will be used in this report to refer to all of the units, men and machines, which acquire, process, and present information to people in the command system. These units handle strategic or tactical information, as well as "housekeeping" information. The artificial distinction between housekeeping information (budget, logistics, personnel, etc.) and strategic or tactical information (enemy actions, weather, weapon status, etc.) confuses design issues because, at times, housekeeping information could seriously influence a tactical decision. The decision to

categorize certain data as housekeeping information and other data as tactical information is arbitrary at best. Within the present command post organizational structure, however, this distinction is maintained.

The weapon system represents the combat capability of the command post. In the command posts with which the Air Force is concerned, it is composed of aircraft and missiles, or some combination of the two. The weapon system is controlled by the line chain of command. The upper echelon commander has the responsibility for exercising control over the weapon system. The intermediate and lower echelon commanders are responsible for implementing the controlling orders of the upper echelon commanders.

The support system provides the men and material needed to maintain the command post. It repairs sensors, installs communication lines, keeps the weapons prepared and performs the other supporting chores needed to keep the command post operational. This system, like the information system, also has an anomalous position in the line-staff organization. One staff officer may be responsible for the performance of one support function, and another staff officer will be responsible for another, related, support function. Although these functions are performed under the direction of the commander, they are usually supervised by staff officers.

The functional organization of a command post is shown in Figure 1. Although this figure shows the information and support systems as integrated systems, it should be remembered that they are distributed throughout the command structure and are not usually treated as systems in the design of command post facilities.

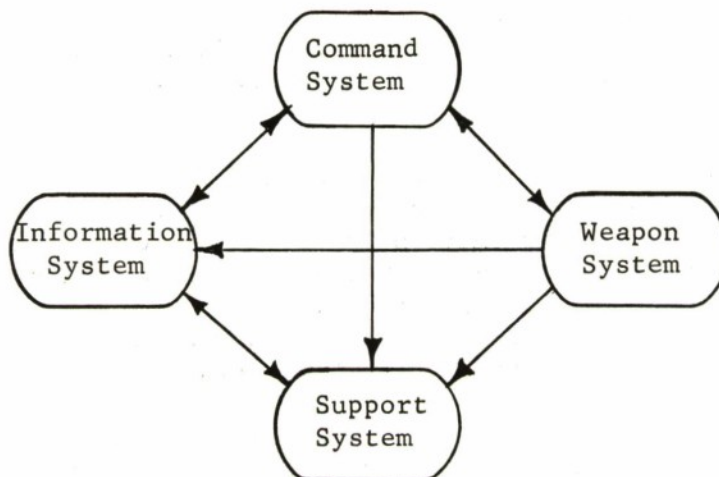

Figure 1. The functional organization of a command post.

2.2.0 The Staff as a Special Problem

The staff officer is in a peculiar position in the line-staff organization of a command post. At times, he is a member of the command system, being responsible for the allocation of some of the command post's resources. In this role, he must have an information unit which supplies him with the data he needs to properly allocate these resources. At other times, the staff officer is a member of the CPIS. In this role, he provides the commander with information about the resources for which he is responsible, as they relate to the operational capability of the command post. To perform this function, the staff officer draws upon the data provided by his information unit, his technical background and experience, and upon information supplied by other staff officers. At still other times, certain staff officers are directed by the commander to supervise the operation of selected units within the CPIS. These information units are responsible for providing either the staff officer or the commander with tactical or strategic information. Thus, a serious source of confusion derives from attempts to find some degree of agreement between an individual staff officer's information processing functions and his organizational role requirements.

As a member of a military organization, one of the prerequisites required of an officer for staff assignment is the possession of appropriate rank or seniority in grade. To a large degree, such seniority in grade is correlated with knowledge in one or more special areas of military content (e.g., supply, personnel, operations planning, etc.). The information processing functions which this same officer must fulfill, however, are increasingly likely to require special knowledge of electronics or associated technologies. As the use of computers as key elements in information processing facilities becomes increasingly common, knowledge of both the hardware and software aspects of computer operations will become necessary. Finally, as these computers become more sophisticated, more attention must be devoted to software issues including such matters as "incremental data assimilation" methods and esoteric storage and retrieval techniques.

While there is no reason why staff officers could not acquire the technical knowledge that is essential to the fulfillment of some of these functions, the attractiveness of such a solution is low. At best, an attempt to fulfill both the organizational role prescriptions and the information handling requirements of a staff assignment would lead to compromising strongly held military values. Rather than mixing even partially incompatible requirements and expecting a single individual to make whatever accommodation he can under the circumstances, it would seem more preferable to recognize the problem and to take steps to eliminate it both at the point of system design and at the point of structuring the command post organization.

2.3.0 Missions and Goals of a Command Post

As we stated earlier, the missions of command posts are theoretically the result of national policy. In general, there are four national objectives which require support from the military: (a) support peacetime interests, (b) deter premeditated war, (c) prevent inadvertent war, and (d) improve the outcome of unavoidable war. These objectives lead to four general categories of military missions which can be arbitrarily labeled: deterrent, defensive, conduct of limited war, and conduct of all-out war.

The deterrent mission of modern command posts is to threaten potential enemies with our capability to retaliate if we, or any of our allies, are attacked. The basic premise behind this mission is that the results of an attack upon us, or our allies, would result in an outcome which would be so terrible that it would be totally unpalatable to an enemy - thereby prohibiting him from launching an attack. The deterrent mission, then, is to be capable of massive retaliation -- and to make such a capability credible to any potential enemy before they attack.

In a sense, the deterrent mission is defensive. Its purpose is to cause an enemy to inhibit any tendencies it may have to attack us. However, what we are calling a defensive mission differs from a deterrent mission. Command posts with a defensive mission actively destroy enemy weapons that would otherwise fall on us. In other words, if the deterrent mission fails and the enemy launches an attack upon us, the mission of our defensive forces is to keep enemy weapons from destroying our population and facilities.

Historically, these are not new military missions. Although modern technological developments have provided new implements for accomplishing these missions, they have been traditionally assigned to a nation's military forces. The conduct of limited war, however, is a result of our times.

The mission of conducting limited war has, in part, grown out of our reluctance to rely completely upon a massive retaliation policy. The attractiveness of limited war as an alternative to total war stems from the fact that, as a matter of national policy, we have foresaken imperialism and foresworn total war. At the same time, we have some confidence that total war does not look much more attractive to the other side. The advent of the thermonuclear bomb seems to have had a decisive influence in this respect by making it highly probable that even a relatively small amount of retaliation would do a large amount of damage.

What distinguishes limited war from total war? The answer is that limited war involves an important kind and degree of restraint -- deliberate restraint. The minimum restraint is that strategic bombing of cities must be avoided. This restraint is a big one, particularly in view of the existing traditions within the Air Force, emphasizing the advantages of strategic bombing. The mission of conducting limited war, then, involves waging war

by conventional means, while exercising restraints which will prevent escalation to total war. The exercise of this mission is contingent both upon enemy actions and upon certain rules which have been established by diplomatic negotiations and by "gentleman's agreements".

In the current "peacetime" military organization, there does not appear to be any single, overall, command post with the primary mission of conducting an all-out war. This, presumably, will be the function of the National Military Command Post, when it becomes operational. Certainly, the conduct of an all-out war will be a primary mission for all military command posts, and the nation, in the event of an enemy attack.

The requirements placed on the design of CPIS will differ appreciably, depending on the command post's primary mission. A command post with a deterrent mission must have information about the enemy's defensive capability, and information about the capability of its own weapon system to penetrate these defenses in order to retaliate. A command post with a defensive mission must have specific information about enemy actions and about the capability of its own weapon system to defend against these actions. A command post with a mission to conduct a limited war, and keep it limited, must have even more information about enemy actions, the capabilities of its weapon system, and the constraints imposed on the use of its weapon system. A command post conducting an all-out war must have information about events occurring on a number of different fronts and about a number of different weapon systems.

It should be noted that a particular command post may have certain combinations of these four missions. For example, a command post which is conducting a limited war may also be responsible for threatening to retaliate if the enemy does not follow the "rules" of such a war. Also, those command posts with a deterrent mission will be instrumental in the conduct of an all-out strategic war, if they fail their cold war deterrent mission. It is the responsibility of the system designer to have a full understanding of the intent and complexities involved in the stated mission of the command post which he is designing.

The system designer should also be aware of the fact that there is a recognized fictional quality to the stated missions of command posts. This fiction is an inherent characteristic of modern military command posts and results from the fact that the people in the command post know that they may never be engaged in actual combat. This is particularly true of the command posts with deterrent and defensive missions. Paradoxically, if they demonstrate the capability of accomplishing their mission, in all likelihood they would not be called upon to exercise this capability.

Such a passive role provides inadequate incentives for the people in the command post. The difficulties derive from the fact that military personnel in such a situation are unable to constantly devote their efforts toward the fulfillment of their primary military mission. They have no means by which to evaluate their own success or lack of success. In order to make life meaningful for the people involved in maintaining these unused military capabilities, a whole set of artificial incentives must be established to provide the mechanism of motivational feedback. Some of these more immediate incentives are provided by external agencies in the form of training exercises and proficiency tests. However, many incentives are generated internally by the commander and his staff. These incentives and objectives are frequently based on military folklore and vested interests that are foreign to the system designer. One of the elements in the military culture, for example, is that promotions are partially contingent on the number of people in a command. Therefore, one of the goals of the command post may be to increase the number of people in the organization. Such a goal may be antagonistic to achieving the primary design goal of maximum effectiveness.

2.4.0 Modes of Operation

In addition to the complexity created by an array of real and artificial missions and objectives, other design problems are generated by the fact that command posts have multiple modes of operation. During most of the lifetime of a command post, it operates in what might be called a standby mode. At periodic intervals, it operates briefly in what might be called an exercise mode, which is a rough approximation of the anticipated combat environment. These exercises are somewhat fictional because no one has fought an all-out war using recent developments in military technology. The modern command post is several technological revolutions removed from any real experience in using the destructive products of advanced science and technology.

In the exercise mode, the commander recognizes that the data flow rate and content as well as other aspects of the information system's operation have been fictionalized. He further recognizes that the exercises provide measures of the performance of the command post as well as providing unit training. Therefore, the commander and his staff may be tempted to "beat the game" rather than trying to operate as they would in a combat environment. They will respond primarily to those attributes of the exercise mode which will influence the proficiency rating, ignoring superfluous data which could be important in the combat mode.

2.5.0 Information Usage in a Command Post

It is clear that there is a certain design paradox or conflict inherent in multi-mission and multi-modal command posts, in the sense that an organizational configuration which would provide effective information usage in the standby mode may not be effective in the exercise mode or in the combat mode. This appears to be one of the most crucial problems in the design of command posts and one that is largely ignored.

The information used in a command post shifts dramatically in both content and rate when the operational mode changes from standby to exercise (or combat). During standby operations, the command system pays only minimal attention to the tactical environment. Information about enemy actions is likely to be vague and more or less incidentally available to it. The pace of critical events is likely to be slow. The command system's activities are directed toward the attainment of internally generated goals such as maintenance or expansion of the command post's resources. Most of the command system's energies are devoted to the assessment of resources and to the planning and conduct of improvement programs. These goals require information about such factors as budget, personnel, facilities, and the status of collateral units. By and large, this information is obtained through internal communications. The major characteristics of these internal communications are: (a) the bulk of it is predictable in time of arrival, but only partly predictable in accuracy and validity; and (b) it is presented in either oral or written form.

The onset of a training exercise acts as a trigger to change the informational requirements in the command post, relative to the information required in the standby mode. In the exercise mode, synthetic information about the tactical environment becomes important, while information from the internal environment assumes a secondary role. It is only in the exercise mode that information about enemy actions is likely to have a direct impact on the command system, or is likely to be very rapidly paced.

The most dramatic portion of the tactical environment is the actions on the part of the enemy. Less dramatic subcategories within the tactical environment also constitute important information sources. These are: changes in weather conditions; other elements of the physical environment, such as geographical characteristics, changes in the characteristics of the ionosphere, etc.; action and status of allied and neutral military units; and changes in the capability of own weapon resources.

Information about enemy actions, weather conditions and other environmental factors are obtained through communication links associated directly with sensors. The major characteristics of these communications are: (a) communications about critical events are usually unpredictable in

time of arrival, accuracy, and validity; (b) the sensor information is perishable and must be perceived and integrated within a short period of time or it will be lost; and (c) the communications are the result of changing the original sensor energy form (electro-mechanical, infra-red, etc.) to another form (pictorial, written, or oral).

Although the general information requirements for the combat mode may be the same as those in the exercise mode, the characteristics of the information are substantially different. People in the command system have no alternative but to "believe" the information provided in an exercise. The command post is being evaluated on the basis of this information. On the other hand, in the combat mode, data will have varying degrees of validity associated with it. Even information about the status of internal resources may be false. Certainly, information about enemy actions will be distorted to whatever extent the enemy is able to employ deceptive tactics. In the combat mode, an effective command system will be highly suspicious of the information supplied by its information system.

It should be noted that the roles of the information handling units in the command post will shift dramatically when the command post goes from the standby to the combat mode. Those units which handle housekeeping information during the standby mode will assume a secondary role in the combat mode. Units providing information about the operational environment will assume a very important role during the combat mode. In fact, this role change is expected to be so dramatic that, to an outsider, it may appear that an entirely new CPIS comes into being. Those information units which will provide information about the tactical environment during combat may be viewed as a separate entity -- and, although this entity will be made up of portions of the CPIS, it will function in an entirely different manner. The design of the CPIS should be such as to allow this transition to take place quickly and effectively.

2.6.0 Decision Tasks in a Command Post

One essential characteristic of a military command post is that the command system must make tactical decisions. Because the potential implications of these decisions are so far-reaching, a high degree of responsibility rests with this system. Therefore, the command system is obliged to plan actions and operations with a considerable amount of attention to detailed information. These planning requirements are most important in the exercise and combat modes of operation. The requirements are less stringent in the standby mode, where more general policies and operating procedures can be laid down.

The decision alternatives available to people in the command system have to do with resource allocation. In the exercise and combat mode, the command system is concerned with allocating combat resources to meet enemy

(real or synthetic) threats. In the standby mode, the command system is concerned with the allotment of resources among the other systems. It should be recognized that, in either mode, the command system does not have a wide choice of options. Its decision alternatives are usually limited, in most cases, to two or three alternatives at any one time.

This is the case throughout the hierarchic levels of command posts. For example, when a high-level commander issues an order to a subordinate commander, he defines a set of decision alternatives for that commander. That is, the subordinate commander can implement the order in several different ways and these constitute his decision alternatives. He must select the most advantageous one. Having made a selection, he issues an order to his subordinate commander, who in turn, is faced with different ways of implementing the order. The way in which the order is finally implemented may be viewed as the product of a multiple-branched decision tree. The set of decision alternatives which are available to a commander at any level is defined by the decision of the commander above him. At each level, the command system requires information from its information system to select the most advantageous of these defined alternatives.

2.7.0 Interrelationships Between Command Post Descriptors

Clearly, each of the preceding descriptors (missions, modes of operation, information usage and decision tasks) are intimately interrelated. Some of these interrelationships are illustrated in Figure 2.

This figure shows that externally generated missions are primarily directed toward the combat mode and secondarily toward the exercise mode. Tactical information is used during these modes so that people in the command system can make decisions about the allocation of combat resources. Some information about the internal environment may be required during the exercise mode, where it is applicable to proficiency tests.

On the other hand, internally generated goals provide direction and incentives during the standby mode. Information regarding budgets, personnel, facilities and the status of collateral units is of primary concern during this mode. This information is required by members of the command system so that standby resources can be appropriately allocated.

DESCRIPTORS

CONDITIONS

Missions & goals

Modes of operation

Information required

Decision task

Externally generated by Hq.

Internally generated by comm. & staff

Combat

Exercise (simulated combat)

Standby

Tactical information -- such as

Synthetic tactical information

Housekeeping information -- such as

- a) enemy actions
- b) status of own resources
- c) weather
- d) other environmental factors
- e) status of friendly & neutral forces

- a) budget
- b) personnel
- c) facilities
- d) status of collateral units

Allocation of combat resources - men, weapons, and support materials.

Allotment of standby resources - personnel and facilities.

Figure 2. Some of the interrelationships between command post descriptors.

2.8.0 Summary

A command post can be viewed as an organization which contains four functional systems; a command system, an information system, a weapons system and a support system. The command post's primary mission is handed down from higher headquarters and is operative only during the combat mode of operation. During the standby and exercise modes of operation, the command post primarily operates under missions and goals which are generated by people in the command post. These missions and goals serve as motivational incentives. The inter-relationships between diverse missions and modes of operations have serious implications for system design. A CPIS which operates effectively under one set of conditions may not operate effectively under other sets of conditions.

3.0 THE AIR FORCE ORGANIZATION

3.1.0 Command Posts in the Air Force

The organization of the Air Force is shown in Figure 3 in relation to the Unified Commands which direct its weapons. It can be seen that no major Air Force organizations are independently responsible for the allocation of weapons during combat. For example, Strategic Air Command (SAC) personnel are trained, supported and administrated through Air Force structures, but they are utilized in the combat situation by a Unified Command directly under the control of the Joint Chiefs of Staff. Fighter interceptor personnel are trained, supported and administered in squadrons of the USAF; however, they are controlled by the North American Air Defense Command (NORAD), a unified inter-nation organization utilizing elements of all U. S. services, plus Canadian forces. The Tactical Air Command (TAC) trains and supports its missile and fighter squadrons. However, these tactical units are under the direction of Unified Theater Commanders and direct line control of tactical operations is drawn from the Joint Chiefs of Staff.

To provide a clearer understanding of this situation, the relationship of the USAF Air Defense Command (ADC) and the NORAD structure is shown in Figure 4. Headquarters ADC owes allegiance to two command elements, Headquarters USAF, and the Commander-in-Chief of the Continental Air Defense (CINCONAD) who is on the Joint Chiefs of Staff. Collectively, these agencies determine the needs and requirements for NORAD. Headquarters USAF is responsible for developing the weapons and training the personnel needed to man these weapons. A large portion of the technical talent of the Air Force is engaged in this work, part of which is administered by the USAF Systems Command, and another part by the USAF Air Training Command.

In the case of fighter interceptors, the pilots are trained under the administration of the Air Training Command, and located at USAF Air Bases. At this point in the organization, however, there is an interesting split. The fighter interceptors and pilots are assigned to a SAGE direction center, part of the NORAD structure. This center will control these interceptors in the conduct of operations related to air defense. Certain portions of the Air Force, then, may be viewed as being part of the support system for the NORAD command post.

3.2.0 An Operational Command Post

To learn something about a command post, we must look to an organization like NORAD. NORAD headquarters is the operational command post which is responsible for defending the air space over and around the North American Continent. To fulfill its mission, NORAD has a complex operational information system monitoring the environment, determining enemy threat, and evaluating weapons resources. Weapon resources are supplied by the Army, Air Force,

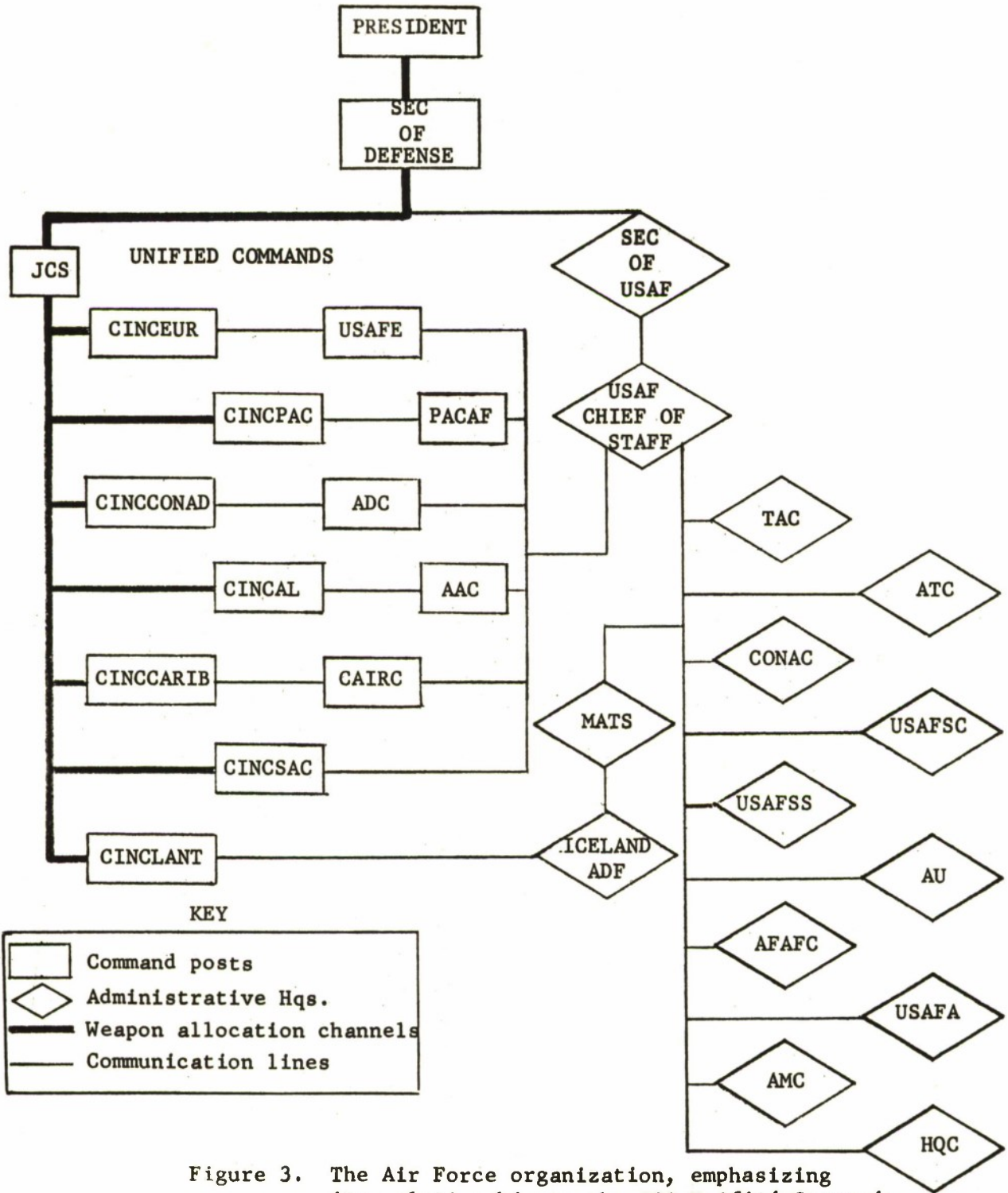

Figure 3. The Air Force organization, emphasizing its relationship to the JCS Unified Commands

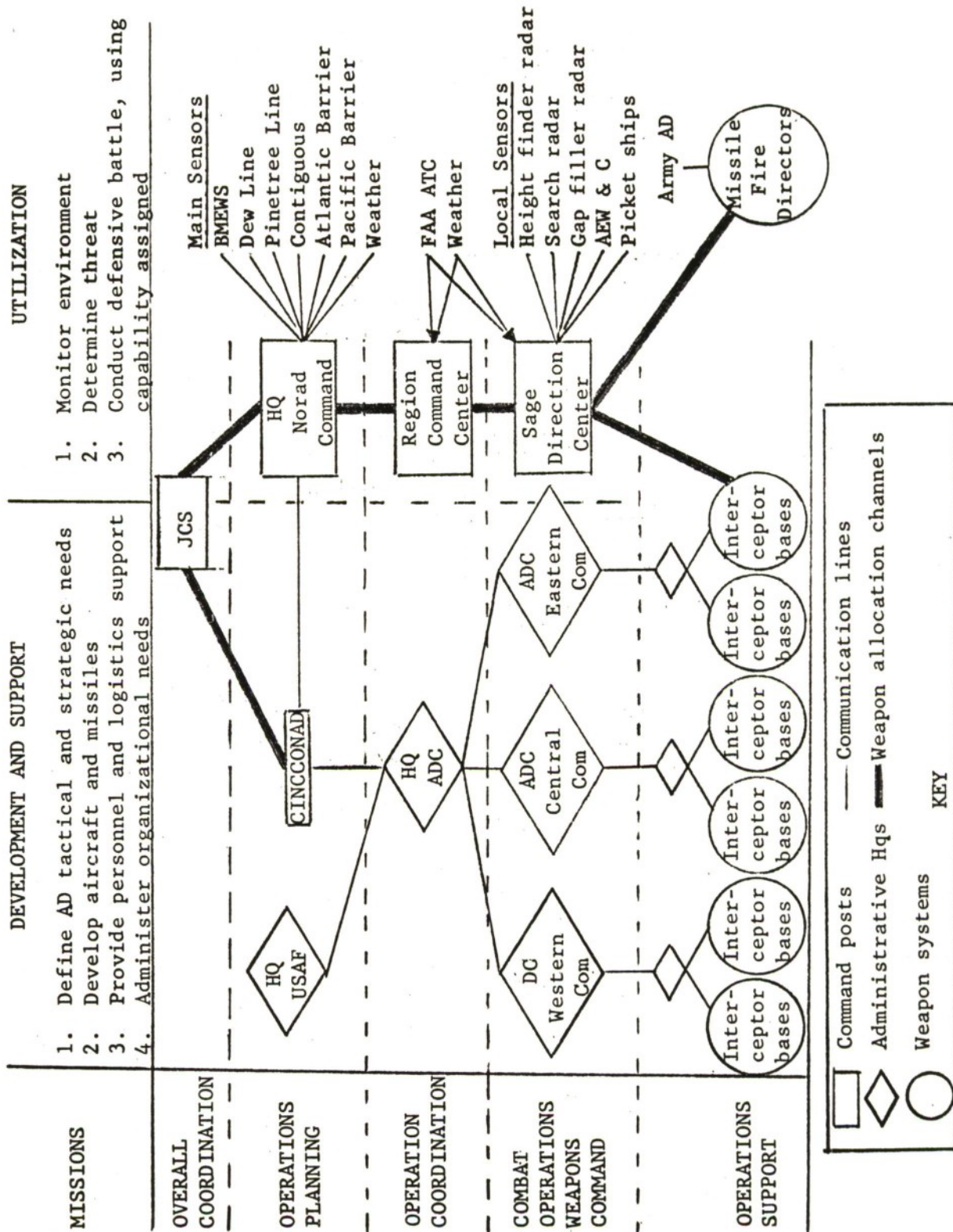

Figure 4. The relationship of ADC to NORAD

Navy, and Canadian forces, and they also provide the essential supporting elements to insure the operational capability of the weapon resources. In direct line, NORAD has SAGE direction centers, which are the command posts that are responsible for the conduct of air defense in prescribed sectors. There are 23 SAGE direction centers throughout the continental U.S. These command posts have locally assigned sensors to gather information regarding their air space and locally controlled interceptors and missiles to defend posts -- having a command system, information system, weapon system and support system.

During normal peacetime (or cold war) operations, a large number of communication and information channels are open in the Air Defense System. These channels can be characterized as direction channels, talk channels and command channels. Direction channels are used to transmit orders concerning administrative matters down the chain of command. Talk channels are used to transmit informal pieces of information, ideas and concepts laterally, up and down within the chain of command. Command channels are used to transmit orders about weapon allocation down the chain of command.

In the combat mode of operation, all direction and talk channels are minimized and the command channel assumes primary importance during the conduct of the air battle. It can be seen from Figure 4 that a large portion of the military structure which accounts for a significant portion of the communications during the standby mode is excluded from the communication loop during the combat mode. For example, ADC and USAF headquarters will be almost completely out of the communication picture during an attack.

In the standby and exercise modes, the CPIS requires many information units to process the amount and variety of information in the direction and talk channels. However, in the combat mode, where the information flow is constrained to the battle environment, a large portion of the CPIS assumes a secondary role. Only those elements which provide information about the tactical environment have a direct line of communication with the commander. It is these elements that Air Force system designers have concentrated on in the past. In its role of providing CPIS for the command posts which direct its weapons, the Air Force has developed a number of systems. These systems are discussed in the following section.

3.3.0 CPIS Developed by the Air Force

It is generally believed that all fifteen Air Force L-systems, which are either in operation or at some stage of advanced development, are CPIS. However, only six of these L-systems were designed to provide the information needed by a commander to control his weapons. These are: 425-L (NORAD's Combat Operations Center), 416-L (SAGE Air Defense System), 465-L (Strategic Air Command's Control), 481-L (CINSAC's Post Attack Command

and Control System), 412-L (Air Weapons Control System of TAC), and 473-L (Headquarters, USAF Command Control System).

The function of the 425-L system is to support NORAD headquarters in its operational functions. This is NORAD's Combat Operation Center. It is a CPIS which provides the NORAD commander with information about the air defense tactical environment. It collects, processes, and displays data to enable the commander-in-chief of NORAD to take full advantage of all aerospace weapons and warning systems available for continental air defense. The radar warning systems providing inputs to 425-L are shown in Figure 5. These consist of the DEW line and Pine Tree Line radar systems, plus the zone-of-the-interior "barrier" radars. In addition, there is the 474-L system, Ballistic Missile Early Warning System (BMEWS), which has major stations in the arctic and over-seas.

In a correlated warning function, we find the 477-L system, which is the Nuclear Detonation Detection and Reporting System (NDDRS) or (NUDETS). Its primary mission is to provide NORAD with information on nuclear detonations occurring within the NORAD zone of responsibility. The radar warning systems and 477-L (NDDRS) may be regarded as being primary triggers to the mobilization of 425-L. They provide sensor input services with some processing for 425-L. They represent a multitude of sensors in very tight communication linkages with 425-L.

On the output side, 425-L provides information downward in the chain of command to all military air defense command posts in the North American continent; both Canadian and U.S. From our standpoint, the primary linkages are directly through the NORAD system to the assigned weapons controlled by the SAGE Air Defense System, 416-L.

SAGE is scattered over the Zone-of-the-Interior at about 23 sites and has the responsibility for providing the information needed to control manned and unmanned interceptor weapons and missiles. It is through the agency of SAGE that NORAD influences Army Air Defense facilities such as Nike-Hercules installations. The data flow in a SAGE Direction Center is shown in Figure 6. Behind 416-L is another system designated 416-M. System 416-M may be regarded as a somewhat more primitive version of 416-L, which provides manual back-up for interceptor control in case a specific 416-L unit is disabled.

The Strategic Air Command Control System (SACCS), 465-L, is located at SAC Hq. near Omaha, Neb. The SAC commander has the ability to individually direct each SAC weapon, either manned aircraft or missiles, because of the information supplied by 465-L. The usual inputs to 465-L consist primarily of status information such as the location and combat readiness of SAC's operational weapons. 465-L will also obtain mission success data in the combat mode.



Figure 5. Norad radar warning net.

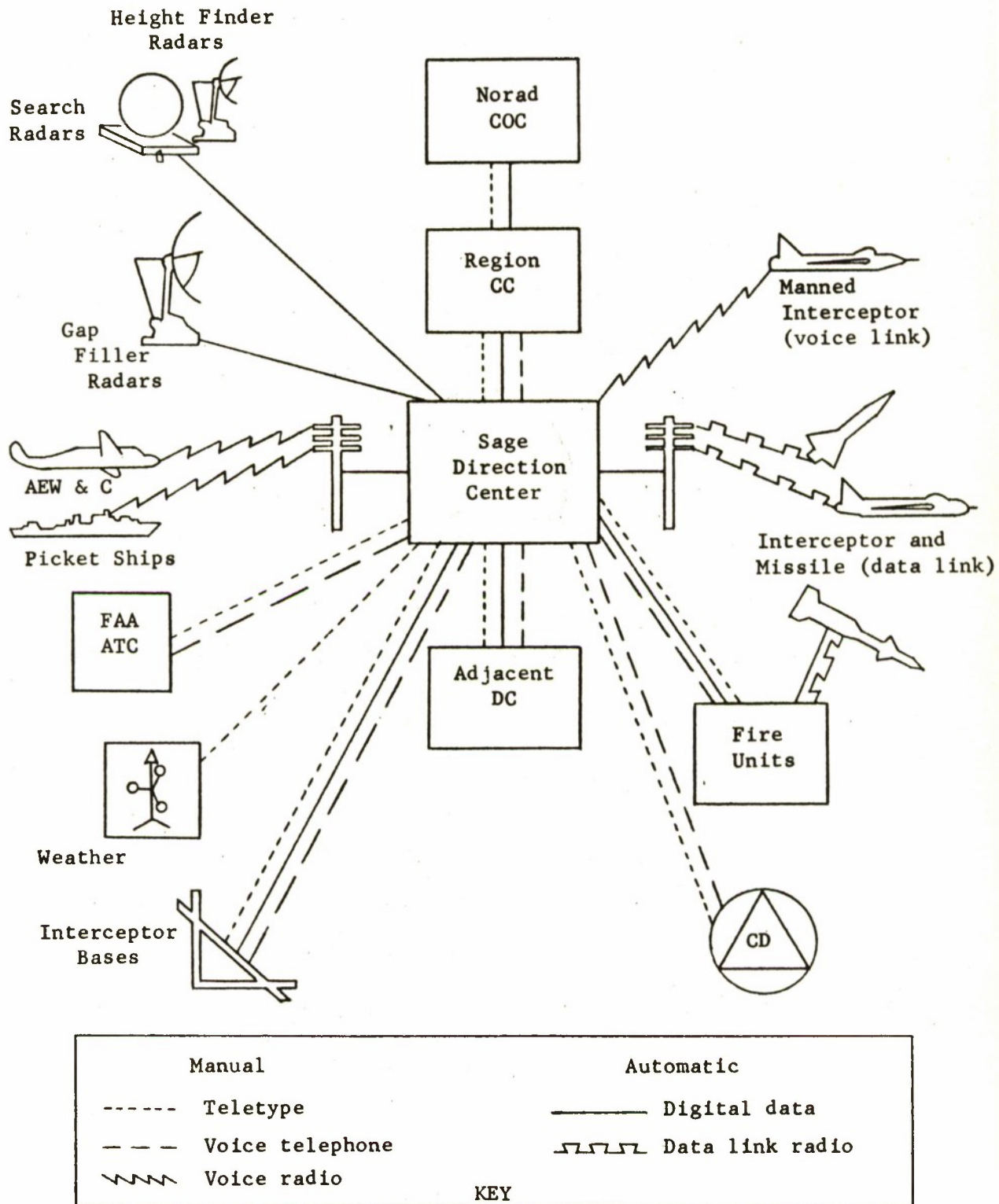

Figure 6. Data flow in a Sage Direction Center

System 481-L is a more compact version of 465-L and is called the Air-Borne Command Post for SAC. It provides an emergency back-up, post-attack reconnaissance facility for the SAC commander or his deputy. It will be used for force allocation over an extended conflict period in case the hardened SAC Hq. is destroyed.

Next, we come to the Tactical Air Command facilities designated as 412-L. This system was formally known in a pre-L series version as TAC-BADGE, and now is designated as the Air Weapons Control System of TAC (AWCS). This system is similar to 416-L in that it also exists at several sites and is part of a command post. It is a transportable command unit facility, which is intended to be able to provide strike control information for tactical air weapons, both manned and unmanned. Because of its tactical mission, 412-L is deployed overseas in its operational form under the cognizance of Tactical Air Command Theater Hq., or Tactical Air Command Divisions Hqs.

System 473-L operates in direct support of the Air Force Commander and his colleagues on the Joint Chiefs of Staff. Since these people exercise direct, though attenuated, control over weapons allocation, 473-L is part of a CPIS. The function of 473-L is to collect status data from all AF units, and also to integrate such status data with the status of allied forces and intelligence data concerning enemy forces, together with any other contextual information that would be relevant to the mounting of an exercise or combat operation.

Figure 7 shows all fifteen of the L-systems in relation to the Air Force organization and the Unified Commands associated with it.

3.4.0 Summary

A study of the Air Force Organization has shown that: (a) the Air Force supplies weapons and information systems for major command posts, but is not responsible for the direct allocation of weapons during the conduct of a battle; and (b) the information systems which are supplied by the Air Force are not integrated CPIS, but provide only tactical information.

Of the fifteen L-systems in existence today, only six are responsible for providing information about the tactical environment directly to a commander. The remaining L-systems provide support facilities for these tactical CPIS, or they provide intelligence data for other Air Force organizations.

4.0 CONCEPTUAL MODEL OF A CPIS

4.1.0 Purpose

A CPIS is a collection of elements which receives, processes and displays information needed by decision-makers to effectively allocate the command post's resources. These resources consist of weapons, personnel, material, energy, information, etc. The decision-makers who are responsible for allocating these resources are organized in a line-staff structure. Typically, the system designer has little to do with providing design inputs for this command structure because it is determined by the Joint Chiefs of Staff. It is accepted as a "given," and the system designer's primary goal is to provide a CPIS which can operate effectively within this structure.

The design options which are available to the system designer concern the type of elements to employ in the CPIS and the organization of these elements within the CPIS. The term, element, refers to a device which can accept information as an input, alter the nature of the input, and generate information as an output. The elements in a CPIS are electromechanical devices and people. The system designer's problem is to formulate a CPIS design composed of these elements which will operate effectively for the line-staff command structure.

The purpose of the conceptual model outlined in this section is to provide the system designer with a framework for designing an integrated CPIS. Such a concept is needed because a design approach which is based only on the requirements generated by the tactical mission and the characteristics of the combat environment is too restrictive.

For example, such an approach ignores the fact that most command posts spend the significant proportion of their existence in the standby mode. In this mode, goals are established by people in the command post which could be in conflict with the command post's primary combat mission. Furthermore, the commander and his staff become habituated to responding to certain channels of information which are related to maintaining the command post. Information about the tactical environment does not directly impinge on these people during standby operations. If the command posts are required to shift from the standby mode to the combat mode, the transition can be time consuming and ineffective. Finally, the information processing technology which has been brought to bear to aid the commander in making tactical decisions is not necessarily compatible with the facilities which he may use to help him make decisions regarding the daily operation of the command post. We believe that a concept which includes organizational factors in addition to mission factors will provide guidelines for the system designer which will result in the formulation of more effective CPIS.

4.2.0 Structure

The primary information channels which operate within a command post are illustrated in Figure 8. The CPIS receives information from the environment and from the command post's support and weapon systems. It processes this information and presents the processed information to decision-makers in the command post's command system. On the basis of this information, the decision-makers issue resource-allocation commands to either the support system or the weapon system. These commands should result in actions which ultimately bring about changes in the information flowing into the CPIS, thereby changing the information which is presented to the command system.

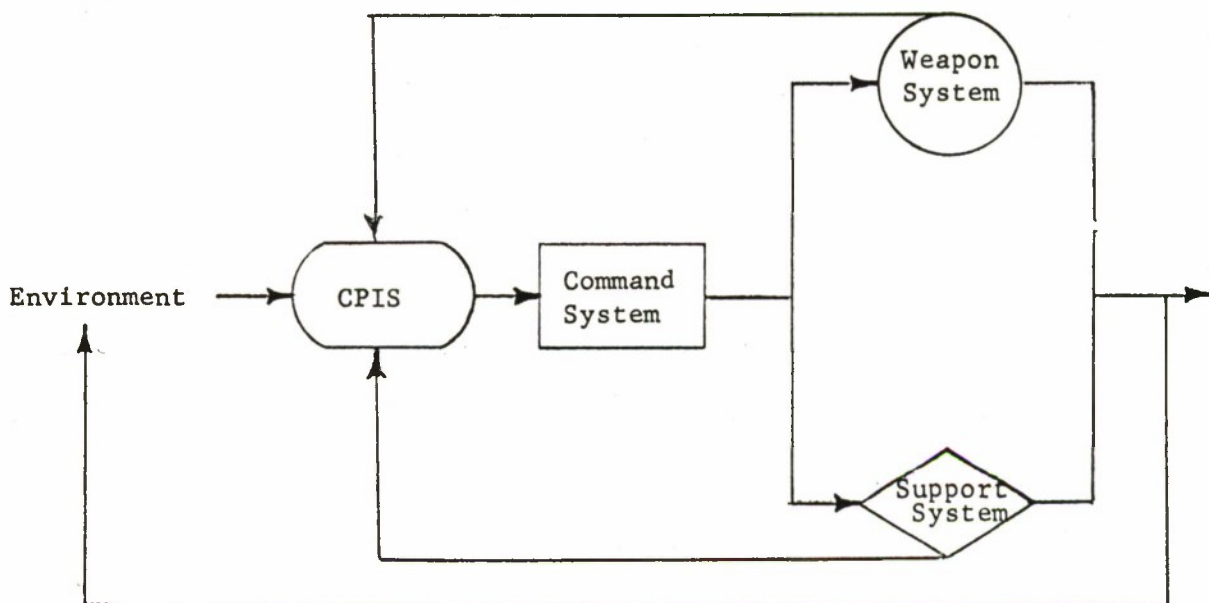

Figure 8. The primary information channels in a command post.

It is clear from this cursory description that command post operations are an entry in the broad category of adaptive or error-corrective phenomena. In this sense, command post operations can be analyzed and described in the terminology of cybernetics. However, it is a serious mistake to assume that such systems, because they have the basic attributes of error or discrepancy detection, corrective action initiation, and feedback, are necessarily analogous to servo-mechanisms. It is preferable by far to consider command posts as instances -- along with homeostatic processes, operant conditioning, and automatic control systems -- of one sub-class of closed-loop, adaptive phenomena. The elaborate and neatly quantitative models which have been developed to support the analysis and design of mechanical and electromechanical servo-systems are not particularly applicable to the analysis and design of command-post systems. Command-posts share only a few, highly abstract attributes with linear servo-devices. The parameters affecting command post performance are far less well understood.

Since most command posts are usually part of a larger military organization, there are information channels between collateral, higher echelon, and lower echelon command posts. A CPIS receives information from lower echelon information systems, processes it, and transmits this processed information upward to higher echelon CPIS. Commands regarding the allocation of weapons flow down the chain of command through lower level command posts. Collateral information flow provides for redundancy where there are overlapping information sensing units, and keeps the CPIS informed of the status of adjacent command posts.

The implications of this organization for the system designer are: (a) higher echelon command posts have more information inputs than lower echelon command posts, requiring more processing; (b) the higher echelon command posts have more reliable information than lower level command posts, where redundant sources of information exist; (c) people in higher echelon command systems make decisions in terms which are broad and abstract, while people in lower echelon command posts are responsible for implementing these decisions; and (d) people in higher echelon command posts suffer longer time delays in receiving information, have less control over the information they receive and suffer long delays in seeing their orders implemented.

4.3.0 Functions

As we have said before, the primary function of a CPIS is to provide the information needed to make allocation decisions. These decisions may be categorized into two types: the decision to allocate certain resources, and decisions concerning how to implement a decision to allocate resources.

4.3.1 Decisions To Allocate

The decision to allocate certain resources is contingent upon the perception by a decision-maker of a discrepancy between the way things are and the way they should be. In other words, the decision-maker's reference is either an explicit or implicit model of a desired state of the environment. When the perceived environment, as described by information from the CPIS, differs from the desired environment, the decision-maker is faced with a decision problem. This situation is illustrated in Figure 9. Whether he decides to allocate the resources which will change the perceived environment or not will depend upon the magnitude of the discrepancy between the perceived and desired state of the environment, and upon the availability of resources. If there is a discrepancy and no resources are available, the decision-maker may be dissatisfied, but no decisions will be forthcoming. Also, the availability of resources presumably biases the decision-maker's tolerance for a discrepancy between the actual and desired environments. If he is plush, he will have a lower tolerance than when he is strapped.

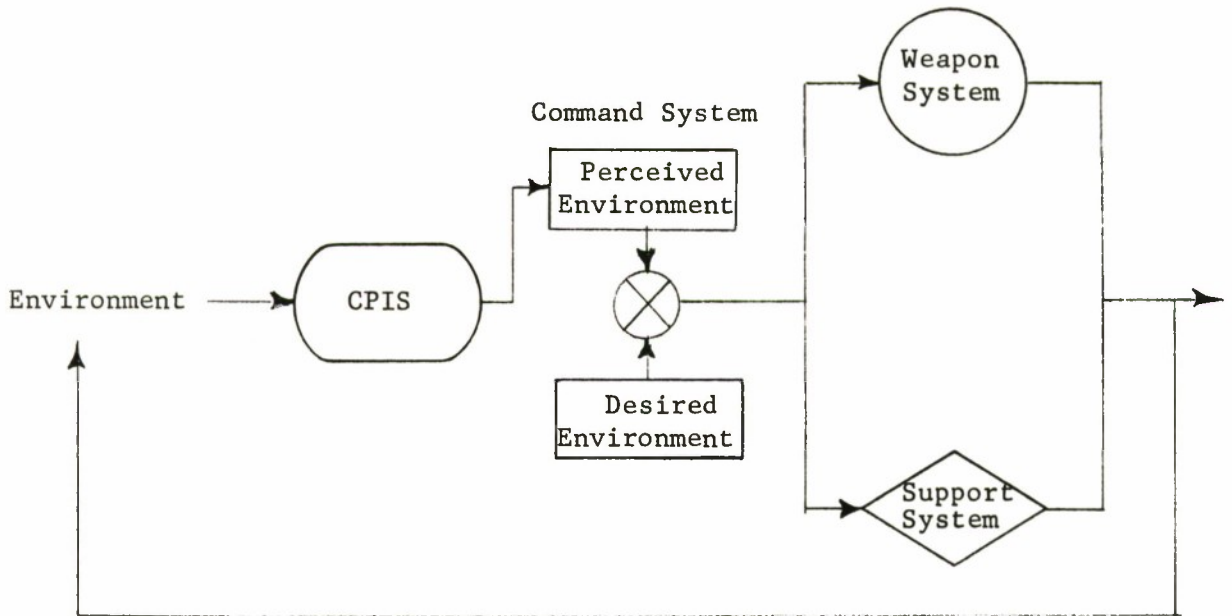

Figure 9. Representation of the comparison process required to allocate resources.

The CPIS must acquire information which can be used to describe the environment for the decision-maker. Ideally, these descriptors would match the descriptors used by the decision-maker to define the desired environment. For example, consider a command post with a deterrent mission. The desired state of the environment for the commander may be described as the absence of a nuclear attack on countries of the free world and the capability to launch a massive retaliation if they are attacked. However, the commander may describe his capability to launch a massive retaliation in terms of a number of descriptors, such as the number of bombers and missiles in readiness, their armament, their delivery accuracy, etc. In order for the commander to easily detect a discrepancy between his desired state of the environment and his perceived environment, the CPIS should describe his perceived environment in the same terms as the commander describes his desired environment.

The model of the desired environment in a combat situation should stem directly from the command post's missions. The correspondence between the commander's concept of a desired environment and the system designer's concept of the descriptors which the CPIS should provide will partially depend upon the explicitness of the mission requirements. If the mission requirements are very explicit, then the system designer should be able to design a CPIS which will provide descriptors of the actual environment which are the same descriptors used by the commander to describe the

desired environment. On the other hand, if the statement is vague, then the commander will rely on his past experience to define his model of a desired environment; and the correspondence between his model and the system designer's descriptors is likely to be less than perfect.

This concept has direct implications for the procedures which the system designer should employ to determine the data requirements for the system. Where mission statements are explicit, the system designer can derive appropriate descriptors of the tactical environment. Where the mission requirements are vague, the system designer should interview a number of potential commanders to determine what level and content of descriptors will be used by them to describe their desired state. It should be noted that, where there is a wide disparity in their answers, an inflexible CPIS design will not be acceptable to all commanders. The CPIS should be capable of encoding its information into a language which is compatible with the commander's vocabulary, to relieve the commander of the job of translating the CPIS information into his terms.

Some of the descriptors that will be useful during the standby mode of operation will depend on the goals established by the individual commander and his staff. However, there probably is a group of descriptors which is required by all command systems. The establishment of this group of descriptors would be very useful to the system designer.

4.3.2 Implementation Decisions

The decision to allocate certain resources automatically limits the number of implementation decision-alternatives facing the decision-maker. There are only so many alternative ways that a command post's resources could be allocated rationally. The decision-maker's task is to select that alternative having the highest probability of producing mission success. The act of selecting one alternative successively defines other sets of decision alternatives, until either the resources are allocated or another decision problem is imposed upon the decision-maker.

The decision-maker requires "information" to choose between the decision alternatives in each set. In this context, "information" is any measurable signal which is functionally related to the probability that a decision alternative will produce mission success. It is represented by I in the general expression,

$$P_{SA_1} = (f) \quad w_1 I_1^{n_1} + w_2 I_2^{n_2} + \dots + w_i I_i^{n_i}$$

where

P_{SA_1} is the probability of alternative one producing mission success.

w is a relative weighting factor normalizing the different metrics used to measure the signal.

n is an exponential weighting factor.

I_i is a measurable signal.

Theoretically, an effective CPIS would provide a simple ordering of the decision alternatives based on the probability of producing mission success for each decision alternative. The decision-maker's task would then be to select the alternative having the highest probability. As an aside, the utility of such a CPIS has been studied experimentally. The experimental CPIS was part of a simulated, airborne, anti-submarine warfare system. Although the results are not conclusive, they indicate that such a CPIS provides advantages that are lacking in more conventional CPIS's.

Looking at information as a measurable signal, which is functionally related to the probability of producing mission success for a decision alternative, has certain advantages from a system design standpoint. For example, it shows the system designer the fallacy of presenting a commander with a complete description of "the situation." In many cases, certain descriptors of a situation will not be related to the decision alternatives available to a commander. This is illustrated in a previous example where it was pointed out that specific descriptors tend to drop out as information travels up the chain of command until, at the level of the President, descriptors such as speed, heading, altitude, etc. of an incoming enemy target are completely superfluous. They are superfluous because the President may be limited to two decision alternatives: attack, do not attack. If he selects the attack alternative, the implementation of this alternative will be left to lower echelon decision-makers where specific descriptors may be needed as information. However, descriptors relative to potential enemy threat, possible enemy intent, etc. are much more important at the presidential level because they are related to the President's available decision alternatives.

In relatively simple systems, the relationship between the probability of success for alternative actions and descriptors used to describe the environment can be specified. Where this relationship can be specified, the elements in the command system can be electromechanical devices. However, most command posts are embedded in a very complex environment, and such relationships cannot be explicitly stated. Contingencies

may arise that a system designer cannot predict. A human decision-maker is required to select the relevant information, properly weight this information, integrate the weighted information and, thereby, estimate the probability of success for the decision alternatives which are available to him. The system designer can help the human decision-maker accomplish this task by designing the CPIS so that it performs some of the filtering and weighting of the information which is displayed to the decision-maker. He can do this by carrying his analysis of the alternatives available to the commander, and the relationship between the alternatives and probability of success, as far as possible.

4.4.0 The Staff Problem

In the past, the military commander could, if he wished, employ his staff as cooperative problem-solvers in dealing with a specific combat situation. He could say, "What should we do now?", and get by that means a better specification of the range of feasible alternatives. The staff could help define the action options available from which the choice could be made. Since the staff had neither final authority nor final responsibility, their thinking could be more open to novel and daring concepts. They also were informed of the alternatives with which the commander was faced, and could actively search for information related to these alternatives.

The formalization of staff functions leads inevitably to a condition where the participation of staff in any operation beyond the acquisition and presentation of specific facts is seriously impaired. Action selection by the commander is, under such conditions, supported primarily by the availability of the physical facts of the threat and the physical facts pertaining to status-of-forces. The staff subordinate does not have, and does not claim to have, any grasp of the contingency rules or cause-and-effect mechanisms which could or should be applied in the decision-making of the commander. The staff tends to become a set of functionaries in the bureaucratic sense, as contrasted with their historic roles as consultants, advisors, or partial substitutes.

It is a historical fact that many military disasters have been due to command failure in the selection of action alternatives. It is reasonable to suggest that such decision failures were not necessarily due to stupidity or lack of competence on the part of the officer in command. More likely, such a commander chose the best alternative from among those which were perceived to be available to him. The "correct" alternative might not have been perceived to exist and, thus, could not be either intelligently accepted or stupidly rejected. The perception of available alternatives is one of the primary functions of a commander's staff. If this staff contribution is lost, it could have a profound effect on the success of military operations.

A new concept of staff organization, reflecting the realities of technical facilities for information gathering, should be advanced. The new staff should be independent of the information system -- much as in modern industry -- where you have service functions such as market research, personnel, purchasing and so forth, under line managers, but the policy decisions are made in concert by an executive committee, whose members are free of day-to-day supervisory burdens and whose role is to conceive of and evaluate alternatives. The "information system" presents information to these executives simultaneously, and they all have an equal chance to exercise their particular talents and backgrounds in determining the alternatives which should be considered. They are also able to direct the "information system" to be responsive to the situation which is of immediate concern and to supply information which is related to this situation.

4.5.0 Discussion

The current design of CPIS reflects the conceptual model of a CPIS to a certain extent. Tactical data displayed at higher levels in the military structure are usually more general and broader in scope than the data displayed at lower command levels, because the people at higher echelons make more general decisions than do the people in lower echelons. This does not necessarily imply that the hierarchic structure of the military system corresponds exactly to a decision chain. One commander may make a number of successive decisions before passing an order down to his subordinates. In this case, he may need certain information to make one decision and different information to make other decisions in the series. This is one of the major problems in designing an effective CPIS for centralized commands. Typically, all possible data relevant to the commander's lowest decision level is either presented or on call. The commander must sort out and process the information he needs, when he is considering a higher level decision problem, from all of the detailed information which may be related to a lower level decision problem.

It should be realized that specifying the levels of decisions which are a commander's prerogative to make is not an easy task. Part of this difficulty lies in an inability to classify different "decision levels." For very simple tasks it is relatively easy to specify possible decision chains. However, complex decisions, like the decision to exercise a pre-emptive attack on a potential enemy, will present difficulties.

Although there is a problem in applying the conceptual model directly to CPIS design, the model is still useful to the system design team faced with a specific CPIS design problem. Practical limits and general categories for decision levels can be derived. For example, the decision to use certain weapons and to initiate certain offensive strategies rests with the President and the Joint Chiefs of Staff. The decision to refuel a specific SAC bomber flying over Omaha at 0900 rests with lower echelon commanders.

The decision alternatives which are available to a military organization are usually severely constrained. They are constrained by Standard Operating Procedures, the command post's mission, and military tradition. For example, in the combat mode those command posts with a deterrent mission are probably more constrained than those with a defensive mission, and those assigned the mission of conducting limited and total warfare are least constrained. Although decision alternatives cannot be specifically defined from the missions of the command post, the missions can be used to narrow the number of decision alternatives to certain classes that have to be considered.

Once the design team has placed the CPIS that is under design consideration into a general decision-level category and defined classes of decision alternatives, it can begin to define the information needed by the decision-makers in the command system. This will not be an easy task. However, portions of the task can be attacked by common sense and analytical methods. For example, common sense would lead us to believe that the decision to launch a massive attack against an enemy will depend very heavily on the type, place and strength of an enemy attack. If an enemy dropped thermo-nuclear bombs on New York, Chicago, Los Angeles, and Fort Worth, the decision would be straightforward. On the other hand, if a conventional bomb was dropped on the Arizona prairie, other factors would influence the decision.

This brief discussion has shown that direct application of the conceptual model to the design of a CPIS would be a difficult task. The specific procedures for applying the model have not been fully developed. There is little doubt that something like the conceptual model discussed in this section will have to be formulated and applied to CPIS design in the future.

The present value of the conceptual model lies not so much in its use as a design construction tool as in its use as an analytical tool.

4.6.0 Summary

The primary function of decision-makers in a military command post is to allocate resources. This involves two types of decisions: the decision to allocate certain resources, and decisions concerning the implementation of the decision to allocate. Both types of decisions are made in the standby and combat modes of operation. In the standby mode of operation support resources are allocated, and in the combat mode weapon resources are allocated.

To make these decisions, the decision-maker must have information. The decision to allocate resources depends upon the perception of a discrepancy between the way things are and the way they should be. The CPIS provides information about the way things are. If the decision-maker has

difficulty in relating the way things are to the way he thinks they should be, he probably will not make effective decisions. An efficient CPIS design would reduce this linguistic barrier as much as possible.

The selection of one way to implement a decision to allocate resources will affect succeeding implementation decisions. Theoretically, the most effective implementation decision would be the one which has the highest probability of producing mission success. Mission success is predictable, to some extent, from information about certain parameters. The CPIS should provide the decision-maker with information about these parameters and, ideally, it should process this information so that the derivation of the most effective implementation decision can be made easily.

The purpose of this conceptual model is to provide the system designer with a framework for designing an integrated CPIS. Although the model is not completely developed, it should prove helpful as an analytical tool for the system designer.

5.0 CPIS DESIGN EVALUATION MODEL

5.1.0 Purpose

Viewed generically, a model is a representation of a system and is used for the purpose of prediction. By performing manipulations on the model, a system designer can predict the effect of similar manipulations when they are imposed on the actual system. In recent years, many people have been concerned with providing models which will provide guidelines for designing CPIS. These models range from abstract mathematical models to very complex simulation models.

Mathematical models suffer from the criticism that the decision processes performed by most military command posts are too complicated to be represented by abstract models. Complex simulation models are subject to the complaints that they are so complex that they do not permit a system designer to understand the nature of the problem, and that adequate criteria of effectiveness are lacking.

The purpose of the evaluation model outlined in this section is to provide the system designer with a model which lies somewhere between these two extremes.

5.2.0 Overview

The basic notion behind the model is to provide a rationale for specifying the inputs to the elements in a command post and for evaluating the outputs of the command post. Specifically, known descriptors of an environment can be provided for the CPIS, a desired state of this environment can be specified for the decision-makers in the command post, and the probability of success for the decision alternatives which are available to the decision-maker can be defined. Once these parameters have been specified, the system design team could study the effect of different information processing functions performed by the CPIS and the performance effectiveness of the command system. Effective performance would be indicated by: (a) the decision to allocate resources when there was a discrepancy between the environment described by the CPIS and the specified desired state of the environment, and (b) the selection of the allocation alternative having the highest probability of success.

It should be noted that the model does not pretend to be "realistic" in the sense that an actual environment is represented. The system designer usually does not possess the necessary military skill and experience required to determine when to allocate and how to allocate resources in an actual military environment. Rather, the model creates an artificial environment where the inputs are specified and the outputs can be measured.

Between the inputs and outputs is a "black box." The functions and organization of the elements in the "black box" can be changed by the system designer so that he can evaluate different CPIS configurations.

5.3.0 Example of the Model

This example will be limited to the performance of a hypothetical Air Defense Commander operating in the combat mode. The desired state of the environment is zero THREAT from enemy aircraft. In the event that the CPIS detects an unidentified aircraft, the commander will be faced with three decision alternatives: (a) Interrogate by radio, (b) Intercept and Interrogate, and (c) Launch a missile. The CPIS will provide information about the enemy aircraft in terms of four descriptors: (a) Range, (b) Altitude, (c) Speed, and (d) Bearing. On the basis of the values of these descriptors, the commander will assess the THREAT. If the THREAT is low, he should employ the INTERROGATE tactic; if it is medium, he should employ the INTERCEPT tactic; and if it is high, he should employ the LAUNCH MISSILE tactic.

The relative threat values associated with the descriptors are shown in Table 1. The sum of the threat values associated with the information about each descriptor will represent the overall THREAT. The relationships between the THREAT and the probability of success for each tactic are shown in Figure 10.

Table 1. Threat values associated with each descriptor.

<u>Least Important Parameters</u>			<u>Most Important Parameters</u>		
Threat Value	Range (100 mi.)	Altitude (10,000 ft.)	Threat Value	Speed (100 knots)	Bearing (degrees)
6	1	1	12	12	12
5	2	2	10	10	24
4	3	3	8	8	36
3	4	4	6	6	48
2	5	5	4	4	60
1	6	6	2	2	72

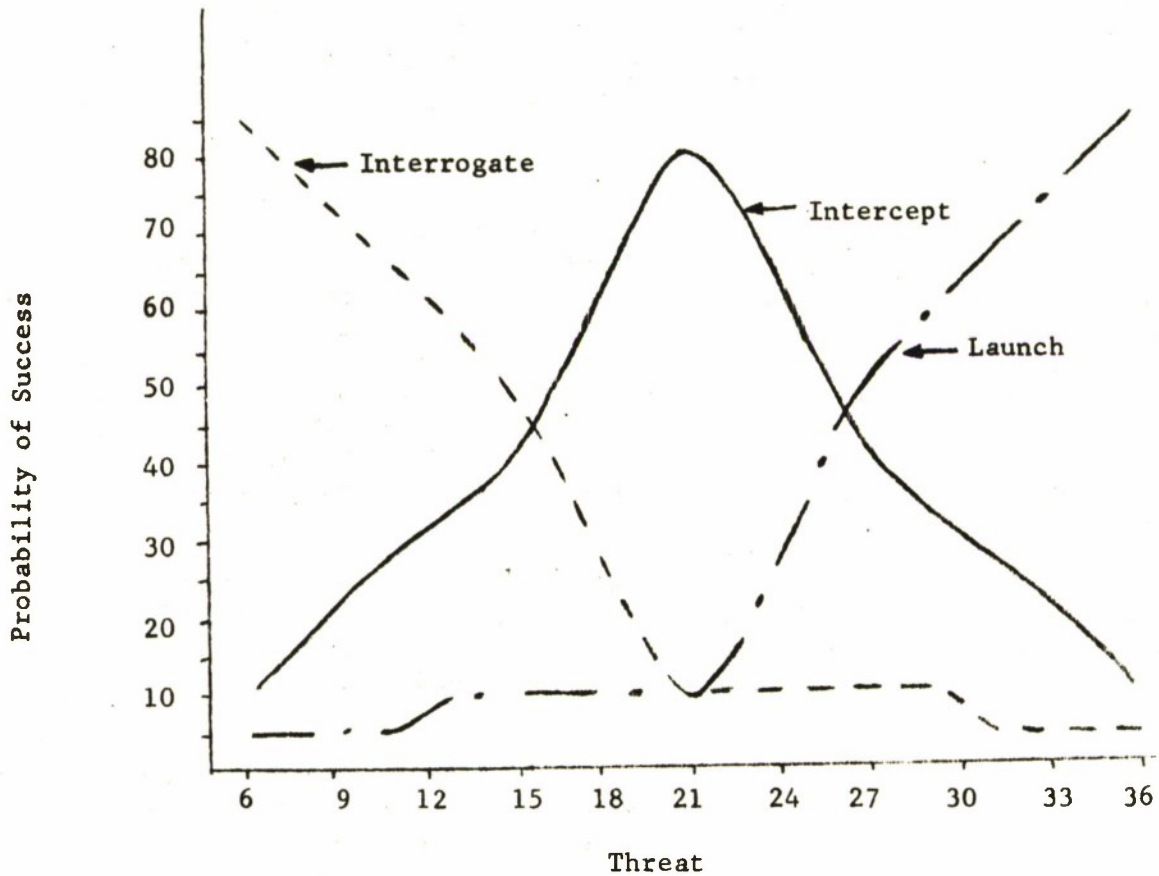

Figure 10. The probability of success associated with the threat value for each of three tactics.

Example: The information displayed by the CPIS about the four descriptors is:

Range (100 mi.)	Altitude (10,000 ft.)	Speed (100 kn)	Bearing (degrees)
5	6	12	48

Reading from Table 1, the THREAT values associated with this information are 2, 1, 12, and 6. The overall THREAT, the sum of these values, is 21. The probability of success for each of the three tactics associated with this threat value is: Interrogate, 0.10; Intercept, 0.80; and Launch, 0.10.

On the basis of the information provided by the CPIS, the commander will select one of the tactics. If the commander selects the tactic with the highest probability of success, he is performing adequately.

5.4.0 Discussion

This example describes the basic foundation for the model. Clearly, it is open to many variations. In this regard, the entire command system could be represented in the model, or parts of the command system could be ignored and only particular aspects of the line-staff structure could be studied. The effectiveness of the CPIS could be studied in the standby mode, involving one set of descriptors or several sets, and the combat mode, involving another set of descriptors. The lack of relevant information (information related to either the desired environment or available allocation alternatives), or the uncertainty associated with relevant information, could be studied.

The model could be "played" with pencil and paper by the system design team for relatively simple situations. More complex situations representing a number of sensors in the CPIS and expansive line-staff structures could be programmed for computer manipulation.

In our opinion, the model will help clarify a number of the design issues which face the system designer. It will also provide the conceptual background for the members of a system design team, so that they can understand how their particular talents contribute to the overall CPIS design.

5.5.0 Summary

The evaluation model is meant to provide the system designer with a method for evaluating the effect of a particular concept or device on the effectiveness of decision performance. The basic approach is to specify the input in such a way that an optimal output can be defined. Deviations from this output will provide indications that the CPIS design is not entirely compatible with the line-staff structure in a command post.

The approach could be implemented if the relationships between the data fed to the CPIS and the decisions which could be made were specified. Deviations from the relationships could then be attributed to the "black box," the CPIS, and the command structure.

DOCUMENT CONTROL DATA - R&D

(Security classification of title, body of abstract and indexing annotation must be entered when the overall report is classified)

1. ORIGINATING ACTIVITY (Corporate author) AIRCRAFT ARMAMENTS INC COCKEYSVILLE, MARYLAND		2a. REPORT SECURITY CLASSIFICATION UNCLASSIFIED	
		2b. GROUP N/A	
3. REPORT TITLE ORGANIZATIONAL MODELS FOR COMMAND POST INFORMATION SYSTEMS			
4. DESCRIPTIVE NOTES (Type of report and inclusive dates) FINAL REPORT			
5. AUTHOR(S) (Last name, first name, initial) NONE			
6. REPORT DATE JUNE 1964	7a. TOTAL NO. OF PAGES 47	7b. NO. OF REFS 0	
8a. CONTRACT OR GRANT NO. AF 19(628)-2960	9a. ORIGINATOR'S REPORT NUMBER(S) NONE		
b. PROJECT NO. 2801	9b. OTHER REPORT NO(S) (Any other numbers that may be assigned this report) ESD-TDR-64-438		
c.			
d.			
10. AVAILABILITY/LIMITATION NOTICES QUALIFIED REQUESTORS MAY OBTAIN COPIES FROM DDC. AVAILABLE FROM OTS			
11. SUPPLEMENTARY NOTES NONE	12. SPONSORING MILITARY ACTIVITY DIRECTORATE OF COMPUTERS HQS ESD L.G. HANSCOM FIELD, BEDFORD, MASS. 01731		
13. ABSTRACT <p>This report attempts to clarify issues concerning the organization and functions of command post information systems (CPIS). The purpose of the report is to provide system designers with a better understanding of factors which influence the operation of a CPIS and which constrain system design alternatives. A CPIS is viewed as one of four systems making up a command post -- the others being a command system, a weapon system, and a support system. The Air Force organization is discussed in the light of this concept, with special emphasis being placed on the relationship of the Air Force to the Unified Commands and the "L" systems. The insights gained from this analysis are incorporated into a conceptual model. This model provides the system designer with a conceptual framework for designing an integrated CPIS. An evaluation model, permitting the system designer to test certain design alternatives has been suggested as an extension of the conceptual model. It is felt that application of these models by a system designer will greatly facilitate the design of a CPIS.</p>			

14. KEY WORDS	LINK A		LINK B		LINK C	
	ROLE	WT	ROLE	WT	ROLE	WT
COMMAND & CONTROL SYSTEMS COMMUNICATION SYSTEMS ANALYSIS DESIGN MODELS DECISION MAKING BEHAVIOR DATA PROCESSING SYSTEMS						

INSTRUCTIONS

1. **ORIGINATING ACTIVITY:** Enter the name and address of the contractor, subcontractor, grantee, Department of Defense activity or other organization (*corporate author*) issuing the report.
- 2a. **REPORT SECURITY CLASSIFICATION:** Enter the overall security classification of the report. Indicate whether "Restricted Data" is included. Marking is to be in accordance with appropriate security regulations.
- 2b. **GROUP:** Automatic downgrading is specified in DoD Directive 5200.10 and Armed Forces Industrial Manual. Enter the group number. Also, when applicable, show that optional markings have been used for Group 3 and Group 4 as authorized.
3. **REPORT TITLE:** Enter the complete report title in all capital letters. Titles in all cases should be unclassified. If a meaningful title cannot be selected without classification, show title classification in all capitals in parenthesis immediately following the title.
4. **DESCRIPTIVE NOTES:** If appropriate, enter the type of report, e.g., interim, progress, summary, annual, or final. Give the inclusive dates when a specific reporting period is covered.
5. **AUTHOR(S):** Enter the name(s) of author(s) as shown on or in the report. Enter last name, first name, middle initial. If military, show rank and branch of service. The name of the principal author is an absolute minimum requirement.
6. **REPORT DATE:** Enter the date of the report as day, month, year, or month, year. If more than one date appears on the report, use date of publication.
- 7a. **TOTAL NUMBER OF PAGES:** The total page count should follow normal pagination procedures, i.e., enter the number of pages containing information.
- 7b. **NUMBER OF REFERENCES:** Enter the total number of references cited in the report.
- 8a. **CONTRACT OR GRANT NUMBER:** If appropriate, enter the applicable number of the contract or grant under which the report was written.
- 8b, 8c, & 8d. **PROJECT NUMBER:** Enter the appropriate military department identification, such as project number, subproject number, system numbers, task number, etc.
- 9a. **ORIGINATOR'S REPORT NUMBER(S):** Enter the official report number by which the document will be identified and controlled by the originating activity. This number must be unique to this report.
- 9b. **OTHER REPORT NUMBER(S):** If the report has been assigned any other report numbers (*either by the originator or by the sponsor*), also enter this number(s).
10. **AVAILABILITY/LIMITATION NOTICES:** Enter any limitations on further dissemination of the report, other than those

imposed by security classification, using standard statements such as:

- (1) "Qualified requesters may obtain copies of this report from DDC."
- (2) "Foreign announcement and dissemination of this report by DDC is not authorized."
- (3) "U. S. Government agencies may obtain copies of this report directly from DDC. Other qualified DDC users shall request through _____."
- (4) "U. S. military agencies may obtain copies of this report directly from DDC. Other qualified users shall request through _____."
- (5) "All distribution of this report is controlled. Qualified DDC users shall request through _____."

If the report has been furnished to the Office of Technical Services, Department of Commerce, for sale to the public, indicate this fact and enter the price, if known.

11. **SUPPLEMENTARY NOTES:** Use for additional explanatory notes.
12. **SPONSORING MILITARY ACTIVITY:** Enter the name of the departmental project office or laboratory sponsoring (*paying for*) the research and development. Include address.
13. **ABSTRACT:** Enter an abstract giving a brief and factual summary of the document indicative of the report, even though it may also appear elsewhere in the body of the technical report. If additional space is required, a continuation sheet shall be attached.

It is highly desirable that the abstract of classified reports, be unclassified. Each paragraph of the abstract shall end with an indication of the military security classification of the information in the paragraph, represented as (TS), (S), (C), or (U).

There is no limitation on the length of the abstract. However, the suggested length is from 150 to 225 words.

14. **KEY WORDS:** Key words are technically meaningful terms or short phrases that characterize a report and may be used as index entries for cataloging the report. Key words must be selected so that no security classification is required. Identifiers, such as equipment model designation, trade name, military project code name, geographic location, may be used as key words but will be followed by an indication of technical context. The assignment of links, rules, and weights is optional.