

2

53.05

SUMMARY REPORT

FEASIBILITY STUDY OF A STAND-OFF GAP SWITCH
IN EXPLODING BRIDGEWIRE INITIATOR

Summary Report

0539-01(06)FP

Handwritten signature

December 1962

U. S. Navy Contract No. N123(62738)26854A

602920

6029 ~~AD~~ No.

DDC FILE COPY

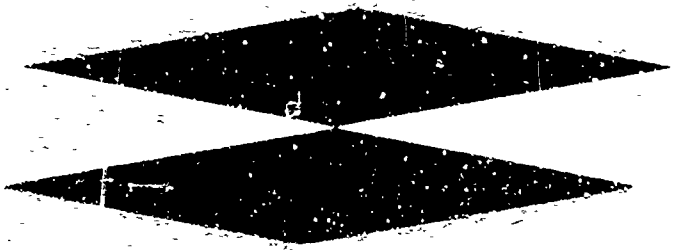

DDC
RECEIVED
JUL 27 1964
ORDNANCE DIVISION

Aerjet-General

CORPORATION



A SUBSIDIARY OF THE GENERAL TIRE & RUBBER COMPANY
AZUSA, SACRAMENTO, AND DOWNEY, CALIFORNIA

AEROJET-GENERAL CORPORATION
Ordnance Division
11711 Woodruff Avenue
Downey, California

FEASIBILITY STUDY OF A STAND-OFF GAP SWITCH
IN EXPLODING BRIDGEWIRE INITIATOR

Summary Report

0539-01(06)FP

U. S. Navy Contract No. N123(62738)26854A

Prepared by: Theodore N. Bryla

Date: 18 December 1962

Reviewed by: *L. Bernow*

No. of Pages: 82

L. Bernow,
Director of Research
Ordnance Division

Classification: UNCLASSIFIED

Approved by: *G. C. Throper*

G. C. Throper
Manager,
Ordnance Division

COPY NO. 9

ABSTRACT

Current design of exploding bridgewire initiators have introduced spark gaps, semiconductors, or diode discontinuity mechanisms within the electrical circuitry of the exploding bridgewire initiator header to meet rigorous electrical safety requirements.

The investigations conducted in this research and development program were to establish the feasibility of incorporating a high voltage switch within the electrical header of an exploding bridgewire initiator and to determine the electrical capabilities of the voltage switch to meet missile safety and functional requirements.

Two types of high voltage switches have been designed, developed, and fabricated within the electrical header of an EBW initiator. The electrical capabilities of these voltage switches have been evaluated under various environmental conditions. Their conformance to the required design parameters establishes the feasibility of including a high voltage switch within the electrical header.

Various stand-off gap switch (SOGS) and stand-off voltage switch (SOVS) engineering models were studied in the feasibility investigation. Fifty prototype SOVS initiator headers of the final design configuration were fabricated and delivered to NOL Corona, California. These units, designed for a coaxial input, utilize the electrical voltage breakdown characteristics of an aluminum-oxide coating for the voltage switch.

ACKNOWLEDGEMENT

Special thanks are extended Mr. F. E. Jacks of the Test Department, Ordnance Division, Aerojet-General Corporation, who assisted in many of the laboratory experiments.

Acknowledgement is also made to Messrs. T. Baxter and T. Harrison of the Sanford Process Co. , Inc. , for their valuable assistance in conducting the experimentation in thin metal oxide insulation coatings.

CONTENTS

	<u>Page No.</u>
1. INTRODUCTION	1
2. DISCUSSION OF STAND-OFF GAP SWITCH (SOGS)	1
2.1 Glass-to-Metal Seal	1
2.2 SOGS Spark-Gap Length and Voltage Breakdown	3
2.3 Final Design of Prototype SOGS Initiator Header	19
3. DISCUSSION OF STAND-OFF VOLTAGE SWITCH (SOVS)	22
3.1 Aluminum-Oxide Coatings	22
3.2 Electrical Characteristics of SOVS Initiators	27
3.3 Evaluation of Prototype Glass-to-Metal Seal Headers	44
3.4 Monitoring Bridgewire Continuity	49
4. CONCLUSIONS	49
REFERENCES	52
APPENDIX A - LIST OF REQUIREMENTS FROM REFERENCE 1	55
APPENDIX B - MANUFACTURING DATA FOR EXPLODING BRIDGEWIRE INITIATOR HIGH VOLTAGE SWITCH	58

ILLUSTRATIONS

<u>Figure No.</u>		<u>Page No.</u>
1	Adjustable Spark-Gap Assembly and Monitoring Instrumentation	4
2	Voltage Breakdown vs Gap Length	6
3	General Design Configuration, NOLC TM 55-80 Initiator	7
4	Prototype SOGS Electrical Header	8
5	SOGS Header, Engineering Model	11
6	Effect of Altitude on SOGS Headers	16
7	SOGS Electrical Heater	17
8	Effect of High Temperature on SOGS Voltage Breakdown Characteristics	18
9	Static Breakdown Voltage Curves for Five Environments	20
10	Final Design, Prototype SOGS Initiator Assembly	21
11	Test Header with Aluminum-Oxide Coated Terminal, and Instrumentation to Monitor Voltage Breakdown. .	24
12	SOVS Assembly and Monitoring Instrumentation	26
13	Engineering Model and Prototype SOVS EBW Initiator Assemblies	28
14	Test Instrumentation for Monitoring Voltage Breakdown and Current-Time Waveshapes	29
15	Voltage Breakdown Characteristics of Engineering Model Initiator Assemblies	34
16	Voltage Breakdown Characteristics of Prototype Initiator Assemblies	35

<u>Figure No.</u>		<u>Page No.</u>
17	Typical Waveshape of Voltage Breakdown Characteristics	36
18	Block Diagram of Instrumentation to Test Effects of High and Low Temperatures on SOVS	37
19	Prototype Models, SOVS Initiator Assemblies	38
20	Final Design, Prototype SOVS Initiator Assembly	42
21	Block Diagram of Instrumentation to Test Effects of SOVS in EBW Circuit	43
22	Prototype SOVS Assembly with 270 k ohm Resistor in Parallel	45
23	Block Diagram of Instrumentation Used with Initiator in Series and in Parallel with EBW Circuit	46
24	Final Design, Prototype Glass-to-Metal Seal Headers	47
B-1	Drawing 3594, Glass-to-Metal Seal Header	61
B-2	Drawing P-1002, Sleeve	62
B-3	Drawing P-1003, Glass Header Sleeve Assembly 3594	63
B-4	Drawing 3595, Glass-to-Metal Seal Header	65
B-5	Drawing P-1005, Electrical Connector	66
B-6	Drawing P-1004, Glass Header Sleeve Assembly 3595	67
B-7	Drawing P-1006, Aluminum-Oxide Coated Aluminum Electrode	68
B-8	Drawing P-1007, Voltage Switch Electrode Header Assembly	70

<u>Figure No.</u>		<u>Page No.</u>
B-9	Drawing P-1009, Coaxial Connector	72
B-10	Drawing P-1008, Outer Case	73
B-11	Drawing P-1001, EBW Initiator Voltage Switch Assembly	74

TABLES

<u>Table No.</u>		<u>Page No.</u>
1	Voltage Breakdown Characteristics of SOGS Engineering Model Electrical Headers with Gap Spacing of 0.0024 in.	10
2	Voltage Breakdown of SOGS Electrical Headers Utilizing Various Electrode Design Configurations and Materials	13
3	Voltage Breakdown of SOGS Electrical Headers, Various Electrode Materials at 350°F	14
4	Voltage Breakdown of 0.062-in. Dia Aluminum Electrodes Coated with 2 Mils Aluminum Oxide	25
5	Test Data for Engineering Model No. 1 SOVS Initiator Assemblies.....	31
6	Test Data for Engineering Model No. 2 SOVS Initiator Assemblies.....	32
7	Test Data for Prototype SOVS Initiator Assemblies.....	33
8	Voltage Breakdown Characteristics of Prototype Model SOVS Initiator Assemblies at High Temperature (+350°F)	40
9	Voltage Breakdown Characteristics of Prototype Model SOVS Initiator Assemblies at Low Temperature (-65°F)	41
10	Test Data for Prototype SOVS Glass-to-Metal Seal Headers	48

1. INTRODUCTION

The purpose of this research and development program was to design, develop, and establish the feasibility of incorporating a voltage switch within a glass-to-metal initiator header unit (NOLC TM 55-80) and to design and develop a prototype for such a unit. The initiator unit must meet the specified electrical safety requirements of Reference 1, which are listed in Appendix A.

Phase I of the program was to be the preliminary design and development of a voltage switch for use in the electrical header of the EBW initiator. Two types of voltage switches were studied; both switches make use of the insulating and electrical breakdown characteristics of an insulating material between two electrodes. One type uses gaseous insulation and is hereafter referred to as a stand-off gap switch (SOGS). The second type uses a solid insulating material (Al_2O_3) and is referred to as a stand-off voltage switch (SOVS).

Phase II, which ran concurrently with the work under Phase I, consisted of the designing and development of 20 engineering models to represent the development of the initiator assembly as the work progressed under Phase I. Various SOGS and SOVS engineering models were fabricated and studied in the feasibility investigation. Upon completion of the engineering models, 50 prototype SOVS initiator assemblies in the final design (the SOVS-type was selected as superior to the SOGS-type) were fabricated and delivered to Naval Ordnance Laboratory, Corona, California. These prototype assemblies represent the design action and experience gained in the investigations and evaluation program conducted under Phase I. The documentation of processing, fabrication, and assembling the selected switch within the electrical initiator header is presented in Appendix B.

The summary of the study relating to the SOGS is presented in Section 2. The summary of the study relating to the SOVS appears in Section 3. Conclusions are presented in Section 4.

2. DISCUSSION OF STAND-OFF GAP SWITCH (SOGS)

2.1 GLASS-TO-METAL SEAL

Discussions with manufacturers of electrical headers with glass-to-metal seals revealed that processes and materials were invariably considered proprietary. Literature on the science and manufacturing technology of glass-to-metal sealing was therefore reviewed. (Pertinent articles not referred to in the text of this report are listed as References 6 through 25).

A glass selected for bonding SOGS metal electrodes should meet five basic requirements: (1) the glass should "wet" and adhere to metal; (2) the linear expansion of the glass must match closely with that of the metal over a wide temperature range; (3) the glass should not "boil" when heated to fusion in making the glass-to-metal seal; (4) it should have dielectric properties sufficient to withstand 3000 v dc without current leakage or breakdown (when used to insulate the metal electrodes of the switch from the metal body or case of the proposed NOLC TM 55-80 header configuration); and (5) the glass utilized in the header should possess adequate density and suitable mechanical properties to enable it to withstand the transient shock forces produced by the initiation of the explosives of the detonator assembly. From consideration of the five requirements in relation to commercially available glass materials, and in conjunction with the following evaluation of metals and metal alloys, a borosilicate type glass, Corning 7052, was selected for use in fabrication of the engineering models.

The material for the metal electrodes of the SOGS header was required to meet these criteria: (1) the metal or alloy should have a low coefficient of expansion when heated from room temperature to the annealing temperature of the glass; (2) its linear expansion should match that of the glass; (3) its oxide at high temperature should be adherent to glass; (4) it should have good electrical and thermal conductivity and emission of electrons with a minimum of sputtering at the high electrical energy levels; (5) it should have satisfactory hardness, toughness, ductility, and machinability properties; (6) it should have good electroplating and organic finishing characteristics; (7) it should be suitable for fabrication by methods and equipment available to the manufacturer; and (8) it should be readily available at low cost.

Kovar, an alloy of iron, cobalt, and nickel, was selected for use in fabrication of the engineering models. As reported in Reference 2, this alloy has a "transition" during its thermal expansion that is almost identical with that of the standard borosilicate hard glasses. The transition occurs at the temperature at which ferro-magnetism is lost (Curie point). The magnetic transformation is accompanied by a three-fold increase in the rate of thermal expansion; namely from 4.75×10^{-6} to 14.25×10^{-6} cm/cm/°C. This particular alloy has the lower expansion of any ternary Fe-Ni-Co series whose magnetic transformation point is high enough to match the transition in the expansion of a corresponding glass.

The unique feature of the alloy is that this transition comes at the same temperature as that of borosilicate glasses, and that the increase in the rate of expansion is also approximately the same as that of the glasses. Hence, it is possible to find a glass whose expansion matches that of a Fe-Ni-Co with a high degree of accuracy over the whole range from 0°C to the softening point.

Kovar, or Fernico, is used extensively in glass-to-metal seal manufacturing. This material is commercially available at a relatively low cost. It has good mechinability properties and meets the requirements for the SOGS metal electrodes.

The investigations of glass and metal materials (reported in detail in Reference 3b) determined that Kovar metal and Corning 7052 glass have the desired physical, chemical, and electrical properties for meeting the specifications for the SOGS electrical header.

2.2 SOGS SPARK-GAP LENGTH AND VOLTAGE BREAKDOWN

A literature review indicated that a considerable amount of data had been compiled concerning two-electrode, spark-gap discharge. However, this data generally concerned larger diameter electrodes, longer gaps, and much higher voltages than are applicable in this study. Many classical theories have also been postulated as to the mechanisms of the breakdown, the significance of time effect, the influence of variables, such as density, electrode spacing, and cathode composition; however, the explanation of the observed phenomena is still highly empirical.

2.2.1 Adjustable Spark Gap Assembly

To establish the spark-gap spacing between the metal electrodes of the SOGS (for meeting the voltage breakdown requirement of 450 v to 900 v), an adjustable spark-gap apparatus with monitoring instrumentation was constructed.

The general view of the adjustable spark-gap apparatus and instrumentation is shown in Figure 1. Basically, the construction of this apparatus consisted of two 0.040-in. -diameter gold plated Kovar electrodes mounted in plastic insulators. One electrode, A in the figure, was mounted in a stationary phenolic insulator, C, and the other electrode, B, was mounted in an adjustable insulating arm, D. The ends of the Kovar electrodes were machined to provide hemispherhical, geometrical shapes. The spark-gap distance between A and B could be set to any desired length by adjusting the micrometer, G.

The test instrumentation used to monitor the voltage breakdown potentials of the various spark-gap lengths was a high voltage dc power supply (Associated Research Hipot, Model 5205). A 50-megohm limiting resistor was inserted in series with the gap to prevent electrode erosion and damage to the ammeter by the large current surge when gap breakdown occurs.

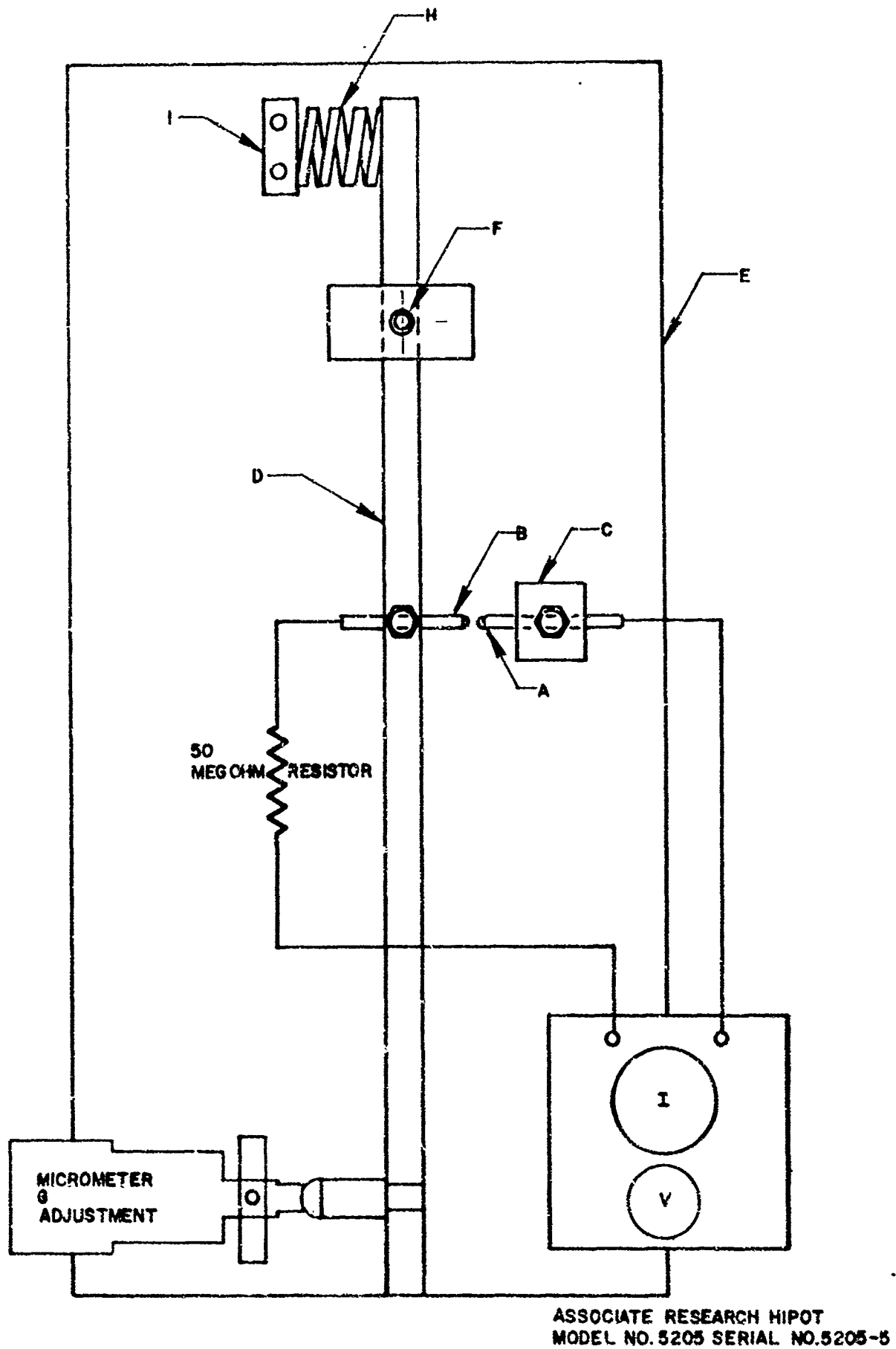

Figure 1. Adjustable Spark-Gap Assembly and Monitoring Instrumentation.

The electrode gap lengths of the assembly were adjusted from 0.000 to 0.010-in. and tested for the voltage breakdown potential under ambient conditions (80°F and 57% relative humidity). The voltage breakdown values were obtained by setting the electrode gap length at 10 mils and decreasing the setting progressively to zero, measuring the voltage breakdown at each setting. The results of the voltage breakdown vs the spark-gap length of the electrodes is shown in Figure 2. The curve indicates that the spark gap lengths for the voltage breakdown range of 450 v to 900 v is between 0.0007 and 0.003 in.

2.2.2 Engineering Model SOGS Headers

2.2.2.1 Voltage Breakdown Characteristics

Fourteen engineering model SOGS electrical headers, simulating the spark gap area configuration of the NOLC TM 55-80 initiator (Figure 3), were assembled for evaluation of the resistance and voltage breakdown characteristics of the SOGS within the header. The design of the engineering model SOGS header assembly is shown in Figure 4. The SOGS was fabricated in a glass-header assembly by press-fitting a phenolic insulator and a brass electrode subassembly into a recessed cavity of one of the glass-header electrodes. The phenolic insulator and the brass electrode of the subassembly were threaded with 0-80 UNF thread as shown in View A. The spark-gap length between the flat end of the Kovar electrode in the glass header and the hemispherical end of the brass electrode of the subassembly could be adjusted by rotation of the brass electrode. The adjustment of the spark-gap length was determined by 10° angular markings on a metal disc secured to the threaded brass electrode.

Each 10° angular rotation of the disc produced a displacement of 0.00035 in. between the electrodes. The electrode zero reference point was established by screwing in the brass electrode until electrical continuity was indicated by an ohmmeter. The disc was then rotated counterclockwise 70° from the zero reference point to give a 0.0024-in. gap between the electrodes.

The test instrumentation and electrical circuitry used to monitor the voltage breakdown characteristics of the SOGS within the prototype electrical header were similar to that of the adjustable spark-gap apparatus.

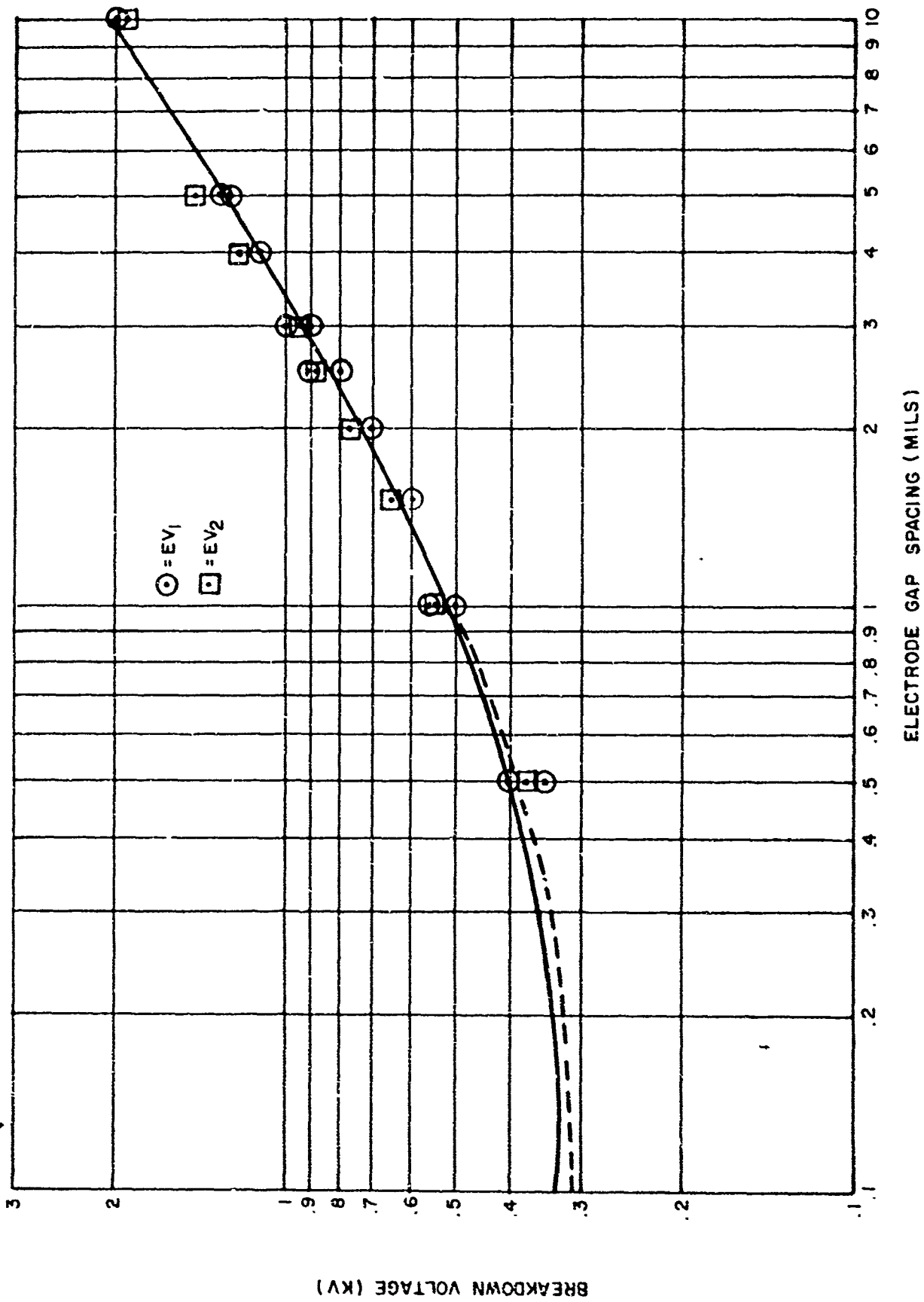

1935-2-1

Figure 2. Voltage Breakdown vs Gap Length.

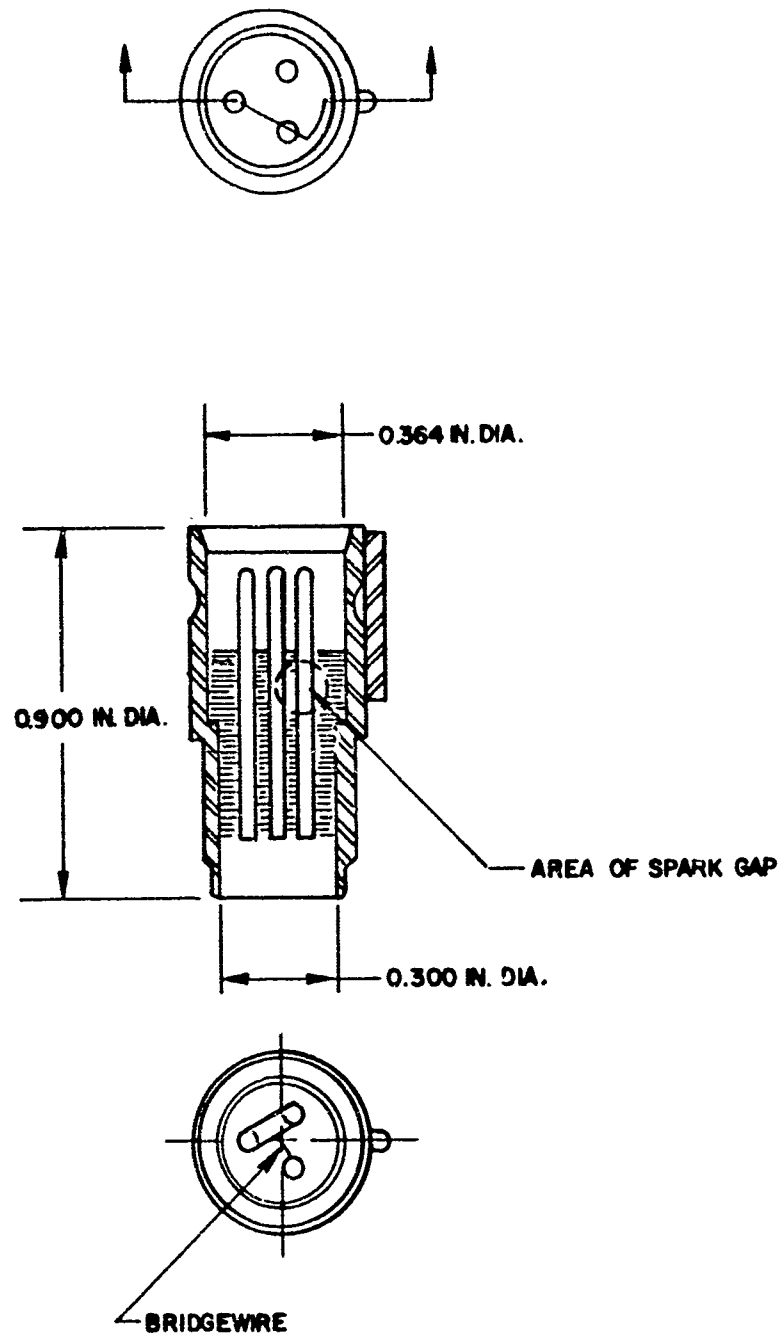

Figure 3. General Design Configuration, NOLC TM 55-80 Initiator.

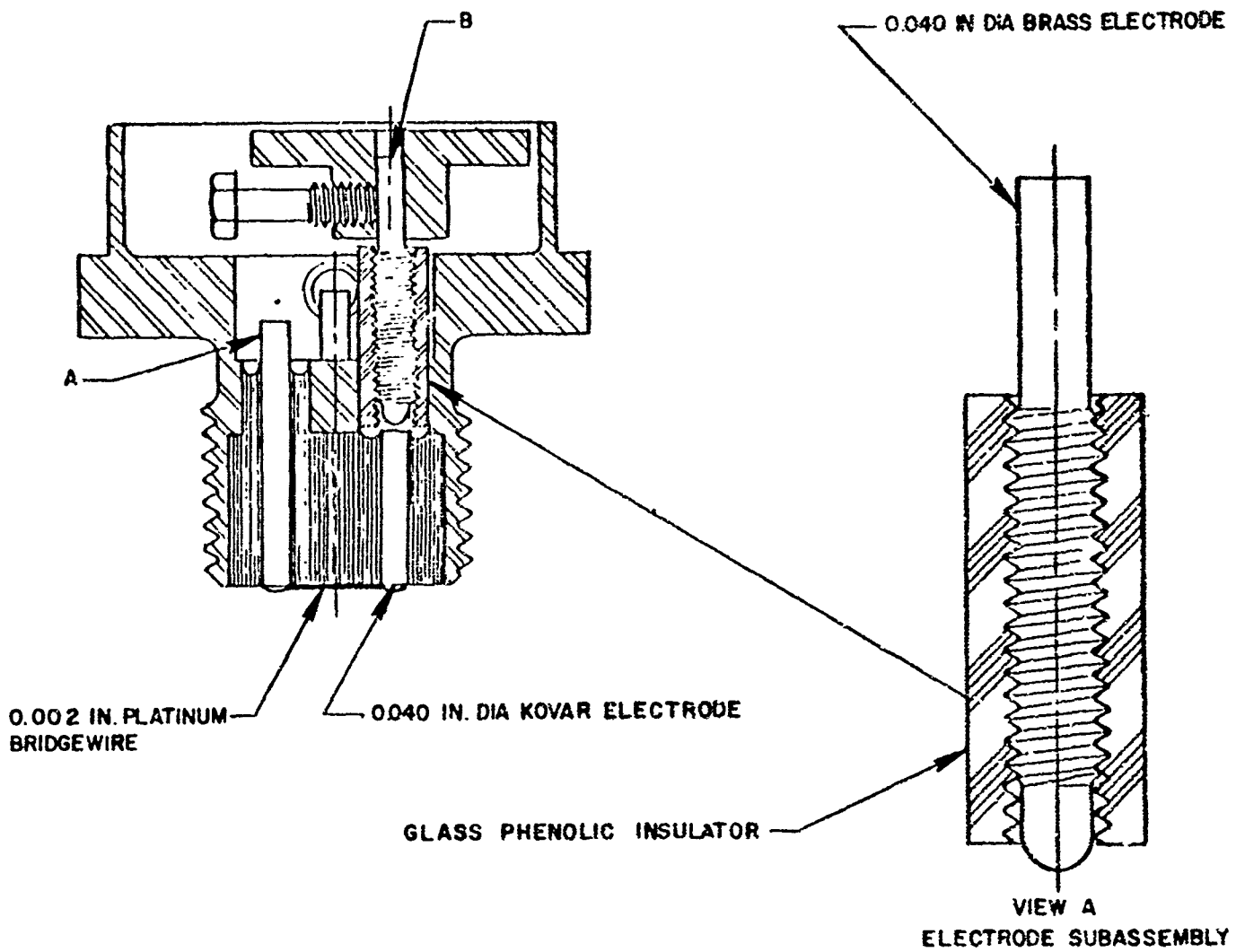
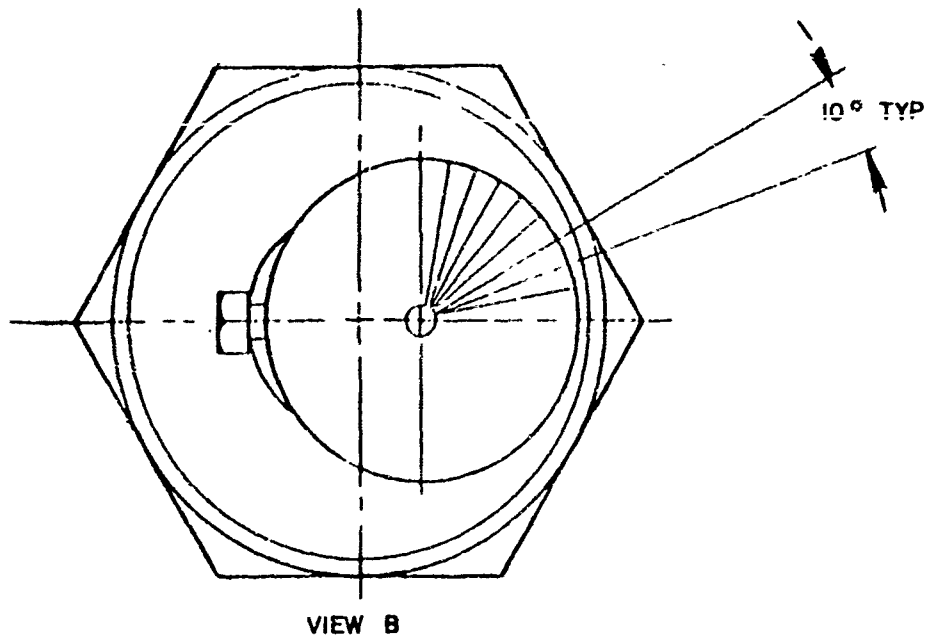

Figure 4. Prototype SOGS Electrical Header.

Table 1 presents the test results of the voltage breakdown of the SOGS within the electrical header when tested under ambient temperature and pressure conditions. The values in column EV_1 are the voltage breakdown measurements with the current flowing from the hemispherical end of the brass electrode to the flat end of the Kovar electrode, while the values EV_2 are the voltage breakdown measured with the current flowing in the opposite direction.

Analysis of the test results of the SOGS prototype header assemblies led to the following conclusions:

- a. The design and method of assembling the SOGS within the electrical header proved to be feasible and to meet the voltage breakdown requirement of 450 to 900 v when tested under ambient conditions.
- b. Reversing the polarity on the SOGS engineering model electrical headers indicated a maximum difference of approximately 7% in the voltage breakdown.
- c. The maximum-minimum voltage breakdown values of EV_1 and EV_2 are within 30% of the voltage breakdown value (800 v) determined for a 0.0024-in. gap in the adjustable gap assembly.

2.2.2.2 Effect of Material and Configuration Changes

Special engineering models of the SOGS header (Figure 5) were fabricated and assembled to test the effect that various materials and electrode configurations had upon the voltage breakdown characteristics. Kovar electrodes with hemisphere-to-hemisphere, point-to-point, and plane-to-plane designs were tested, as well as electrodes of 52 Alloy and cold-rolled steel (B1113) in hemisphere-to-hemisphere designs. The spark gap was adjusted from 0.0005 to 0.010 in. during these tests.

The SOGS engineering model body (A in Figure 5) was fabricated from Kovar material, and the two glass-to-metal seals, B, assembled into the header body were Kovar glass-to-metal seals, press-fitted and soldered into the cavities provided in the Kovar body. The internal diameter of the Kovar sleeves, C, of the glass headers were line-tapped with 0-80 UNF threads so that the threaded metal electrodes, D, would be in an accurate alignment.

The spark gap lengths of the various SOGS engineering model electrode designs were adjusted by mounting each assembly in a small vise on the traveling stage of a Bausch and Lomb micrometer comparator and positioning each assembly so that the gap length could be observed through the sight holes, E, in the body.

Table 1. Voltage Breakdown Characteristics of SOGS
Engineering Model Electrical Headers with
Gap Spacing of 0.0024 in.

SOGS Header No.	Breakdown Voltage, EV ₁	Breakdown Voltage, EV ₂	Current, I _{μa}
1	700	725	1.0
2	700	700	1.0
3	650	600	1.0
4	675	675	1.0
5	700	675	1.0
6	750	725	1.0
7	780	780	1.0
8	700	675	1.0
9	725	700	1.0
10	750	760	1.0
11	730	725	1.0
12	725	725	1.0
13	650	625	1.0
14	850	790	1.0

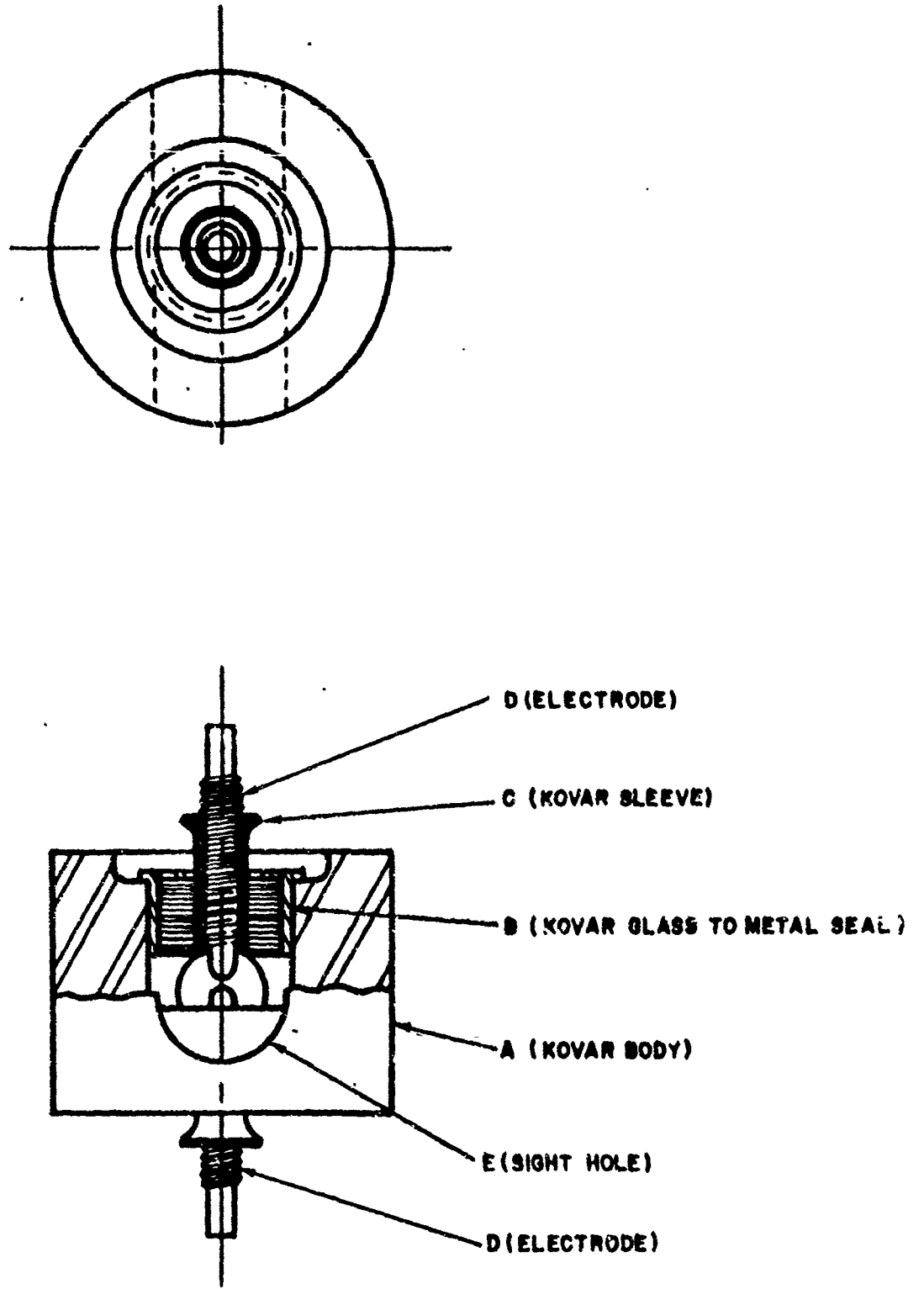

Figure 5. SOGS Header, Engineering Model.

1033-6-1

The instrumentation used to monitor the voltage breakdown characteristics was the same as that used in the previously described voltage breakdown tests.

Table 2 presents the results of the voltage breakdown characteristics at ambient temperature conditions. The test data indicated that the materials and design configurations under study had no adverse effect upon the voltage breakdown characteristics at ambient conditions.

2.2.2.3 Effect of High Temperature

Ten SOGS engineering models with hemispherical electrodes (Figure 5) were fabricated for testing voltage breakdown characteristics at 350°F. The bodies of the SOGS headers were fabricated from Kovar. Kovar glass-to-metal seals were soldered into the Kovar bodies with high-temperature solder. The electrodes were also soldered in the Kovar sleeve after the gap lengths were adjusted. The engineering models were placed in a Delta oven with Teflon coated electrical leads extending out of the oven. The leads were connected to the terminals of the Associated Research Hipot power supply and the voltage breakdown at +350°F was measured.

Table 3 presents the results of the voltage breakdown tests of the SOGS engineering models at 350°F. In general, voltage breakdown values decreased by between 75 and 100 v of the ambient values.

2.2.2.4 Effect of High Altitude Environment

Studies of the voltage breakdown or flashover voltage between electrodes and between an electrode and the metal case of the glass-to-metal seal headers were made by exposing in a vacuum bell jar the SOGS engineering models (Figure 5) to altitudes from sea level to 100,000 ft. The geometric spacing of the metal electrode to the metal case of the headers used in these tests was identical to that in the NOLC TM 55-80 header design shown in Figure 3.

Prior to testing the headers, the current leakage from the vacuum-chamber feed through terminal posts to ground was established at sea level and at 100,000 ft. At sea level and 78°F, with 5000 v applied, the current leakage from the terminal posts to the base plate was less than 0.05 μ a. With 2250 v applied at 100,000 ft and 78°F, the leakage between the terminal posts and from the terminal posts to the base plate was approximately 2 ma. This value dropped to 0.1 ma with 1300 v applied.

Table 2. Voltage Breakdown of SOGS Electrical Headers Utilizing Various Electrode Design Configurations and Materials.

SOGS Header Electrode Cap Length (Mils)	Breakdown Voltage of 0.040-in. Dia Kovar Electrodes with Hemisphere-to-Hemisphere Design (volts)	Breakdown Voltage of 0.040-in. Dia Kovar Electrodes with Plane-to-Plane Design (volts)	Breakdown Voltage of 0.040-in. Dia Kovar Electrodes with Point-to-Point Design (volts)	Breakdown Voltage of 0.040-in. Dia 52 Alloy Electrodes with Hemisphere-to-Hemisphere Design (volts)	Breakdown Voltage of 0.040-in. Dia Cold-Rolled Steel (B111) with Hemisphere-to-Hemisphere Design (volts)
0.5	325 150	275	400	373 400	400
1.0	500	500	500	550 600	500
2.0	700 725	700	700	750	600
3.0	875 880	875	800	900 925	800
4.0	1025 1050	1000	950	1025 1050	1050
5.0	1175 1200	1100	1050	1175 1200	1225
6.0	1325	1200	1200	1325 1350	1375
7.0	1435	1350	1300	1475 1500	1450
8.0	1550	1475	1450	1600 1625	1600
9.0	1700	1625	1600	1725 1750	1750
10.0	1850	1725	1800	1850	1900

Note: (1) Voltage Breakdown of SOGS electrical headers were tested at 76°F and Relative Humidity of 51%.
 (2) Voltage Breakdown of electrode gaps monitored with current flow of less than 1 μa.

Table 1. Voltage Breakdown of SOGS Electrical Headers, Various Electrode Materials at 350°F.

SOGS Electrical Header with 0.040-in. Dia Hemispherical 52 Alloy Electrodes-Cap Length (mils)	Initial Voltage Breakdown at 76°F and 56% Relative Humidity (Volts)	Voltage Breakdown of SOGS Headers when Exposed to 350°F Temperature Conditioning (Minutes)										Voltage Breakdown of SOGS Headers After Temperature Conditioning at Ambient Conditions	
		5	10	15	30	45	60	120	240	300			
SOGS Electrical Header with 0.040-in. Dia Hemispherical Kovar Electrodes-Cap Length (mils)	700	600	550	550	550	550	550	550	550	550	550	550	690
	1050	950	950	950	950	950	950	950	950	950	1000	-	
	1400	1350	1350	1350	1350	1350	1300	1300	1300	1400	1500	1650	
	1600	1550	1550	1550	1550	1550	-	-	-	-	-	-	
SOGS Electrical Header with 0.040-in. Dia Cold-Rolled steel (B1113) Electrodes-Cap Length (mils)	675	600	600	600	600	600	600	600	600	600	-	675	
	1050	1000	1000	1000	1000	1000	950	950	950	-	1050		
	1400	1300	1300	1300	1300	1300	1300	-	-	-	1500		
	1550	1500	1500	1500	1500	1500	1500	1475	-	-	1600		

Figure 6 illustrates the test results. Curve A represents the flashover voltage for pin-to-pin from 675 v at sea level to 500 v at 100,000 ft. Curve B illustrates the flashover voltage for pin-to-case from 2500 v at sea level to 550 v at 100,000 ft. Curve C shows the flashover voltage from the electrode, or metal terminal pin, to the metal case of only one glass-to-metal seal header.

Since the flashover voltage of the SOGS electrical header from terminal pin to metal case was approximately 550 v at 100,000 ft, application of 2,200 v will result in flashover and the bridgewire will not receive the energy necessary for initiating the explosive. From these data, it was apparent that the header assembly must include a positive hermetic seal to ensure the desired electrical function of the EBW initiator when it is subjected to high altitude conditions.

2.2.2.5 Effect of High Temperature on Hermetically Sealed Units

Investigations of problems related to electrical connectors for electrical initiators at high altitudes have found that the flashover voltage on typical electrical connectors varies with changes in air density. All types of exposed electrical terminations can be expected to behave in this manner. At the higher densities, high voltages may be used if the terminal spacing is widened; but at the low densities, or high altitudes, the effect of the spacing becomes less significant.

The breakdown voltage between electrodes is a function of the product of gas pressure and the length of the gap separating the electrodes, as stated by Paschen's Law. As the gas density and pressure decrease, the flashover voltage reaches a minimum; further decreases in pressure result in a slight increase of the breakdown voltage (Reference 4). A hermetic seal would control variations in this product by maintaining a constant pressure about the electrodes despite the effect of altitude.

To reduce variations in the value of Paschen's product when a SOGS is subjected to high temperature, two SOGS engineering model headers (Figure 7) were assembled and hermetically sealed under controlled atmospheric conditions. The units were placed in an oven, and a series of voltage breakdown measurements at temperatures from 78° F to 350° F were made. The results are presented in Figure 8, which shows a breakdown voltage increase around 500 v. Upon completion of the high temperature tests, the units were allowed to cool to room temperature, and voltage breakdown measurements were again made. The measurements were within 50 v of the original room temperature breakdown values.

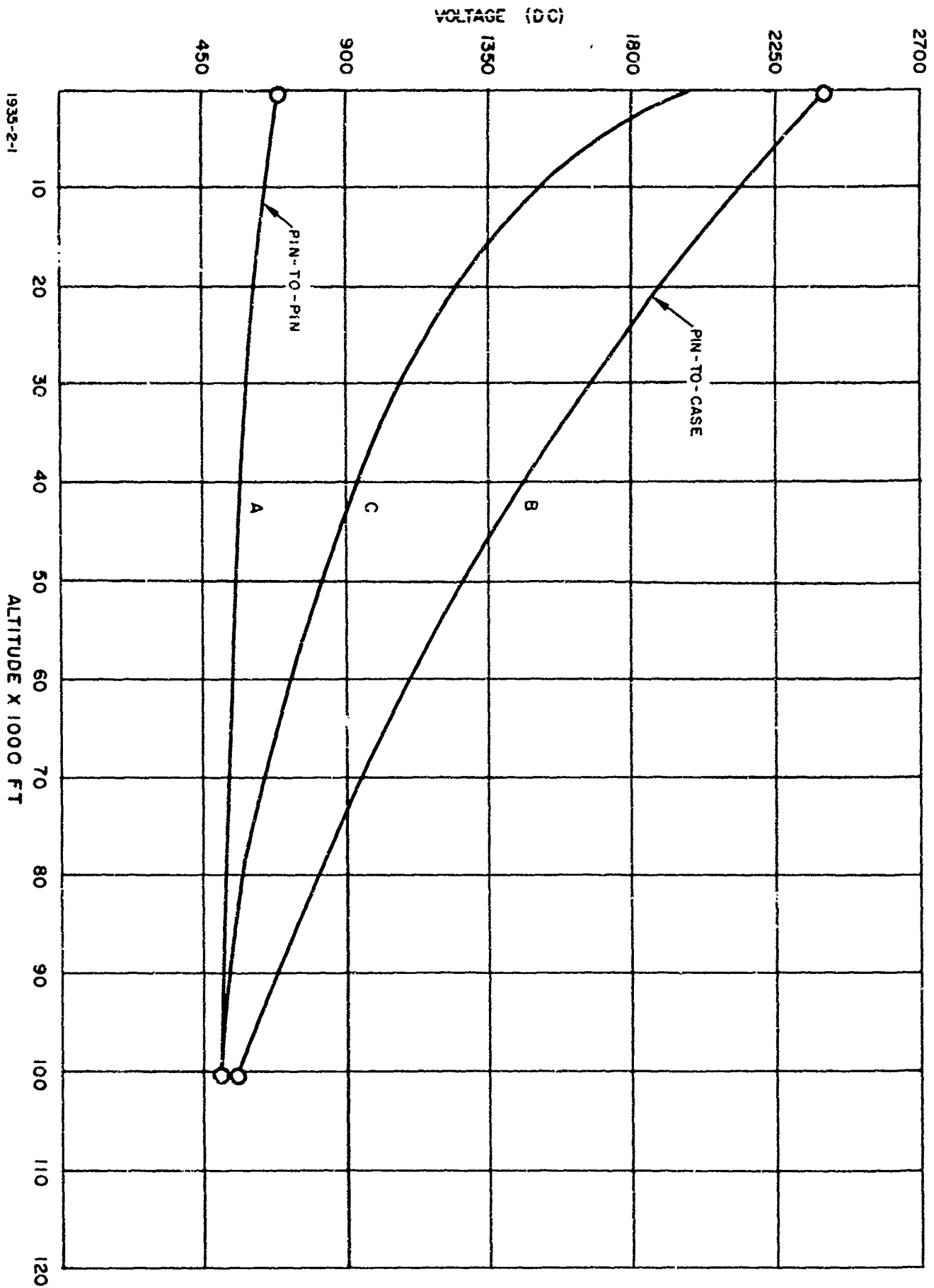
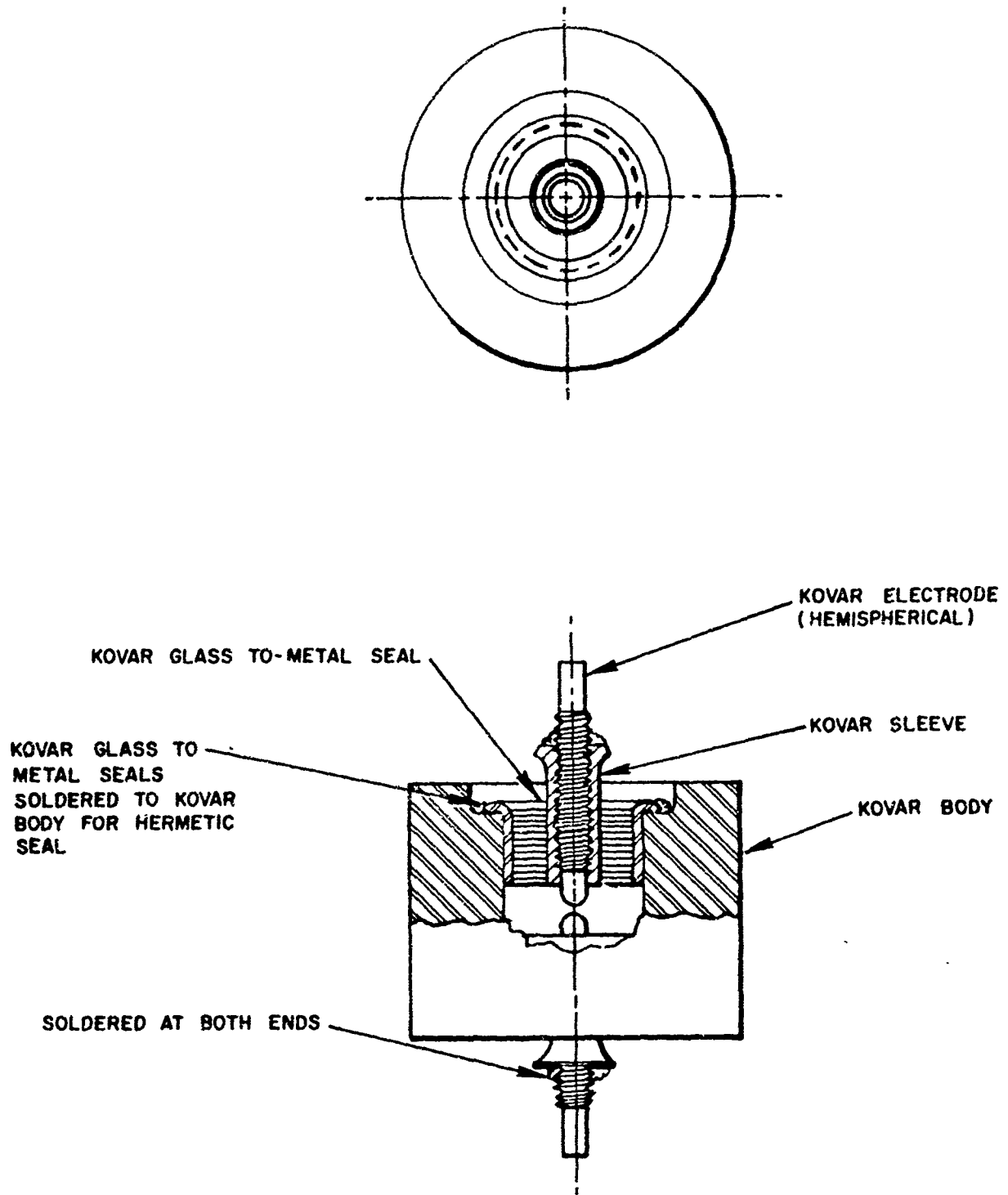
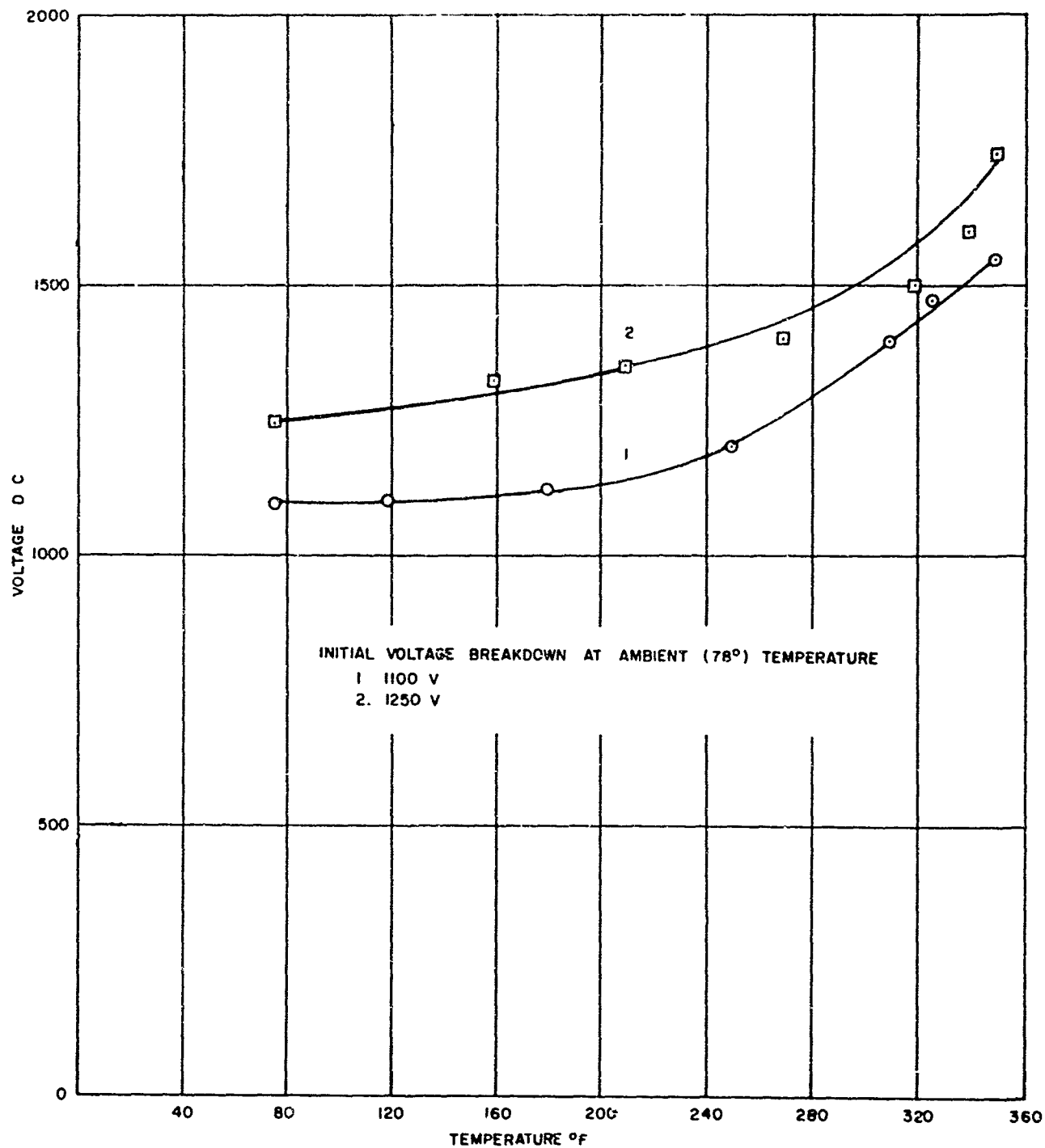

Figure 6. Effect of Altitude on SOGS Headers.



1936-8-7-1

Figure 7. SOGS Electrical Heater.



1935-5- -1

Figure 8. Effect of High Temperature on SOGS Voltage Breakdown Characteristics.

Unsealed SOGS engineering models exposed to temperatures of +350° F showed a decrease of 75 to 100 v in the voltage breakdown from the initial value at room temperature. The voltage breakdown of hermetically sealed SOGS increased by from 450 to 500 v upon heating to +350° F.

In relation to these findings, Meek and Craggs (Reference 5) studied the electrical breakdown of spherical electrodes in different environments. Figure 9 presents the pd (pressure-gap length) curves compiled from those studies of nitrogen, hydrogen, argon, helium, and air vs breakdown voltage. These curves indicate that use of the inert gases (argon or helium) in the sealed electrode cavity of the header would require a longer gap or higher pressure than the use of nitrogen or air for the equivalent breakdown voltage.

2.3 FINAL DESIGN OF PROTOTYPE SOGS INITIATOR HEADER

The study and analysis of incorporating the SOGS within the NOLC TM 55-80 initiator configuration resulted in requiring modification of the design. Altitude tests and energy transfer evaluation indicated that the header design should be modified to one with a coaxial type connector in lieu of the suggested multipin connector, for providing better insulation. Changes in the initiator design were also necessary for meeting the 3000 v pin-to-case stand-off voltage requirement. Hemisphere-to-hemisphere electrode design was determined to be the most easily reproducible without misalignment problems.

Figure 10 is the final design of the prototype SOGS initiator assembly. The header has an extension of approximately 0.250 in. of glass material, which mates into the Teflon sleeve of the DAGE 95712-2085-1 coaxial connector. This extension provides a longer insulating surface between the inner conductor and the outer conductor for high altitude conditions. When tested for voltage breakdown, this design met the minimum 3000 v pin-to-case requirement.

The SOGS is assembled in the initiator assembly in the following manner:

- a. The glass sleeves (1 and 2 in Figure 10) are given a glass-to-metal seal, then line reamed. The adjustable-electrode portion (1) is tapped with 0-80 UNF thread, thus ensuring perfect alignment for the assembly of the Kovar electrodes.

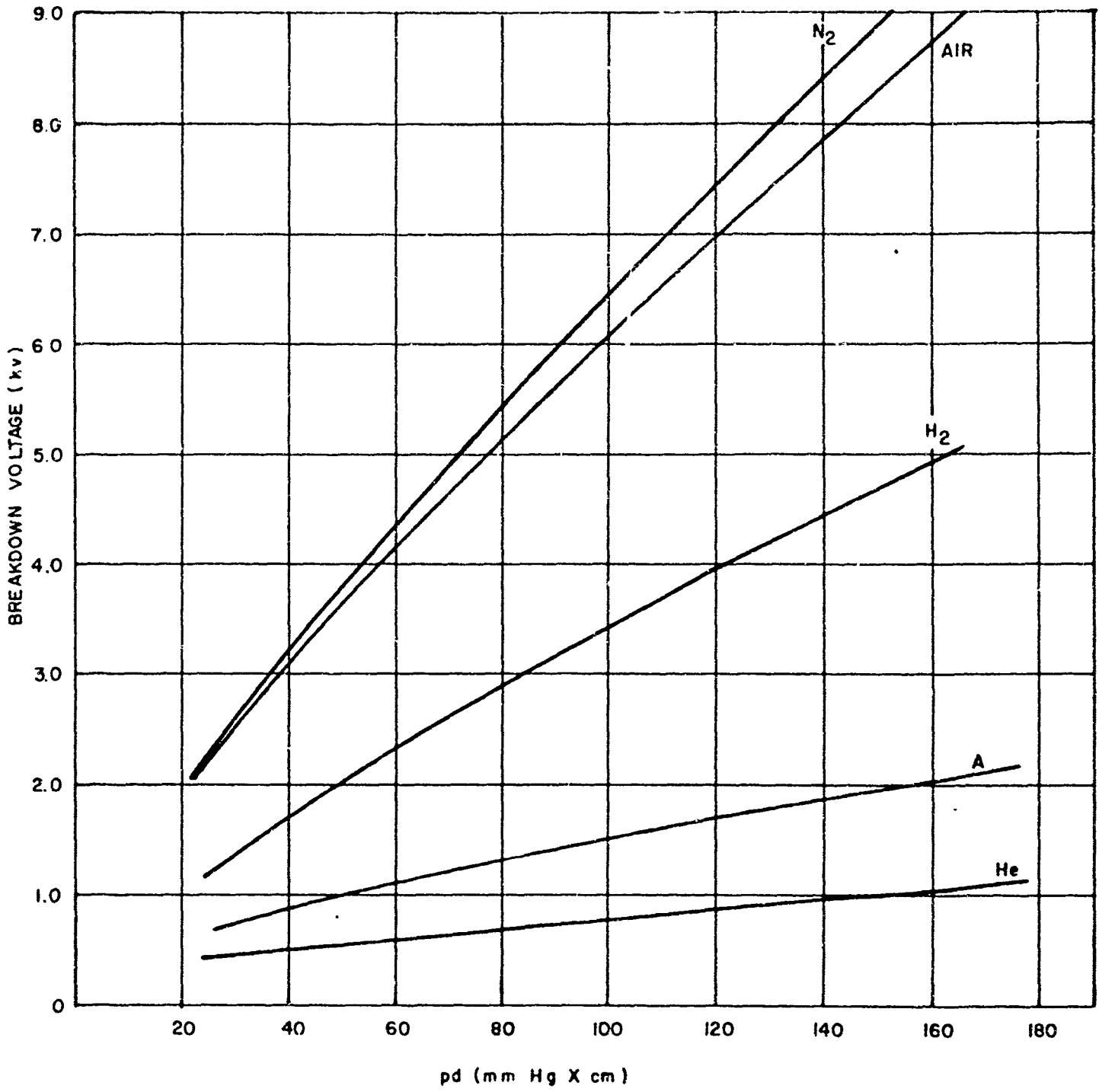

1935-9-1

Figure 9. Static Breakdown Voltage Curves for Five Environments.

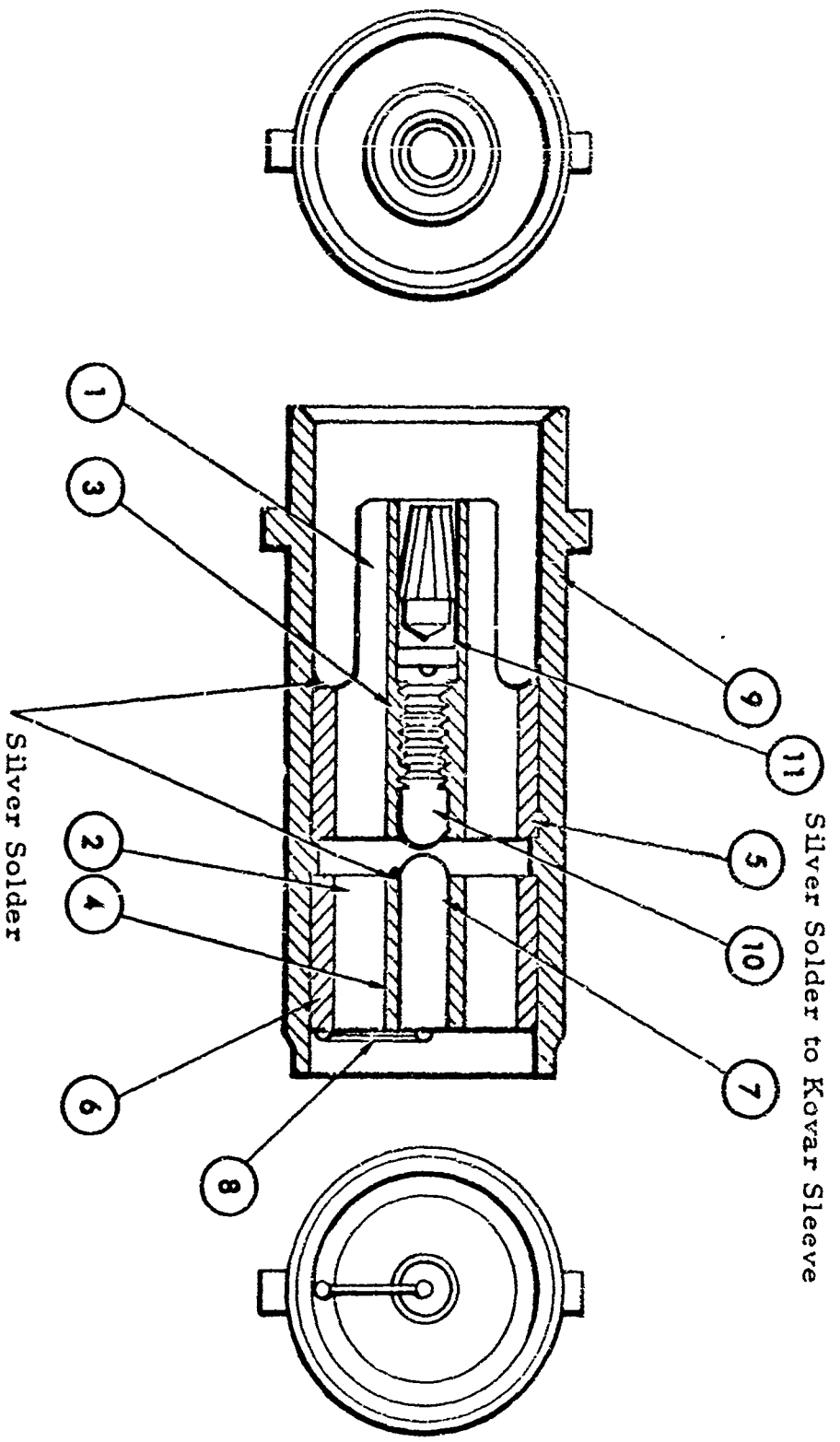

- LEGEND
- 1 and 2 - Glass Sleeves
 - 3, 4, 5, 6 - 7052 Glass to Kovar Metal Seal
 - 7, 10 - Herispherical Kovar Electrodes (0.040-in. dia)
 - 8 - Bridgewire
 - 9 - Kovar Outer Case
 - 11 - Electrical Socket Connector (DAGE 95712-UG-931U)

Figure 10. Final Design, Prototype SOGS Initiator Assembly.

- b. The stationary Kovar electrode (7) is press-fitted into the glass-to-metal inner sleeve (4) and induction soldered to it. The bridgewire (8) is mounted between the stationary electrode and the outer glass-to-metal seal (6) and soldered in place.
- c. This assembly is inserted into the outer case (9) and induction soldered to it.
- d. The threaded Kovar electrode (10) is assembled into the inner sleeve (3). This segment of the inner assembly is press-fitted into the outer case and induction soldered.
- e. The threaded Kovar electrode is adjusted to the desired gap length and is induction soldered into place.
- f. Electrical socket (11) is assembled into the extension of the sleeve behind the adjustable electrode and is induction soldered.

3. DISCUSSION OF STAND-OFF VOLTAGE SWITCH (SOVS)

3.1 ALUMINUM-OXIDE COATINGS

The study of literature on insulating materials suggested the use of electrolytically deposited coatings as an insulating medium in a stand-off voltage switch. Thin aluminum-oxide coatings appeared to be a suitable replacement for a gas-insulated gap switch. The ability of the aluminum-oxide coating to act as an electrical insulator is dependent upon its thickness. The thickness of an oxide film formed on the surface of an aluminum anode is substantially in direct proportion to the value of the applied potential used during electrolysis. The film offers a very high resistance to further passage of current and, with constant potential applied, the current will decrease to a minimum steady state.

Normal methods of electrolytically depositing aluminum-oxide on aluminum have been employed commercially for many years. The proprietary process most commonly used is Aluminite 226 (Hardas and Sanford). A more recent process developed by the Sanford Process Co. Inc. is similar in application to other anodizing processes except that the aluminum-oxide coating can be obtained in an exceptionally short period of time which permits the achievement of a deeper coating with high density and excellent hardness characteristics.

The exact nature of the process has not been disclosed, although it contains both a mineral acid, such as sulphuric, and an organic additive. The normal sequence of operation is vapor degreasing, immersion in the electrolytic bath for a controlled time, and controlled cold water rinsing. Temperatures range from 0° F to 15° F, considerably lower than in other processes. Voltage ranges from 15 v to as high as 150 v dc. The current density is 12 to 15 amp/sq ft.

Development of an aluminum-oxide coating for a SOVS within an electrical header to meet the required electrical characteristics was undertaken. Electrolytic deposition of high density aluminum-oxide in thicknesses of 0.0015 in. to 0.003 in. on 2-ft lengths of aluminum rod material (0.0625-in. diameter) of various metallurgical compositions was conducted by the License Division of the Sanford Process Co. Inc.

In preliminary investigations to evaluate the voltage breakdown characteristics of the aluminum-oxide coating ten test units were assembled as shown in Figure 11. Samples 1 through 5 were fabricated from 90% pure 250 aluminum. Samples 6 through 10 were fabricated with aluminum of the following chemical compositions: aluminum 99.54%, carbon 0.10%; manganese 0.25%; silicon 0.05%; sulphur 0.035%, and phosphorus 0.025%. The test results shown in Table 4 indicated that an aluminum-oxide coating of 2-mil thickness could be utilized for a stand-off voltage switch material.

Aluminum electrodes with 1.5- and 2.0-mil-thick aluminum-oxide coatings were tested in series for current leakage vs applied voltage, and for voltage breakdown characteristics. Figure 12a schematically represents the test situation to monitor the first indication of current leakage and Figure 12b is the test set-up for voltage breakdown. The electrical current path in both cases is from the brass terminal to a metal connector, through the oxide coating to the aluminum electrode, through the oxide coating on the other end of the aluminum electrode to a metal connector, and to the other brass terminal. The current thus passed through a total thickness of two oxide coatings. Prior to assembling the stand-off voltage switches, coated electrodes were boiled in distilled water and dried in an oven at 300° F for 2 hr. Every precaution was taken in the assembly of these units to prevent any contamination of the aluminum-oxide coating.

Five 1.5-mil-thick-coated electrode voltage switches were conditioned in an oven at 300° F and tested for voltage breakdown after removal from the oven. The breakdown voltage ranged from 650 to 750 v. The voltage breakdown for six other SOVS electrodes with a 1.5-mil-thick aluminum oxide coating were tested under ambient conditions of 88° F and relative humidity of 44%, the voltage breakdown ranged from 750 to 775. Three SOVS electrodes with a 2-mil-thick coating were tested under ambient

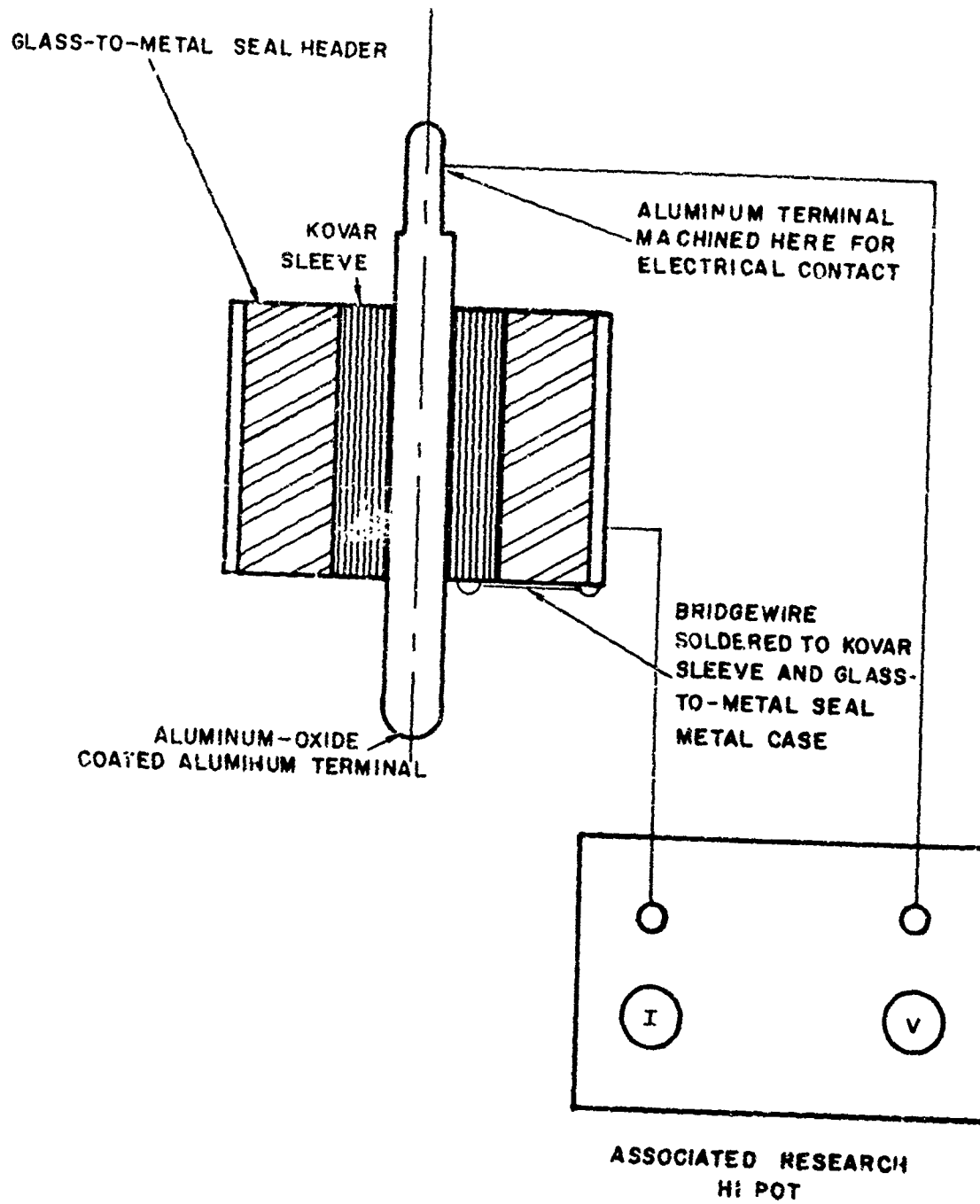
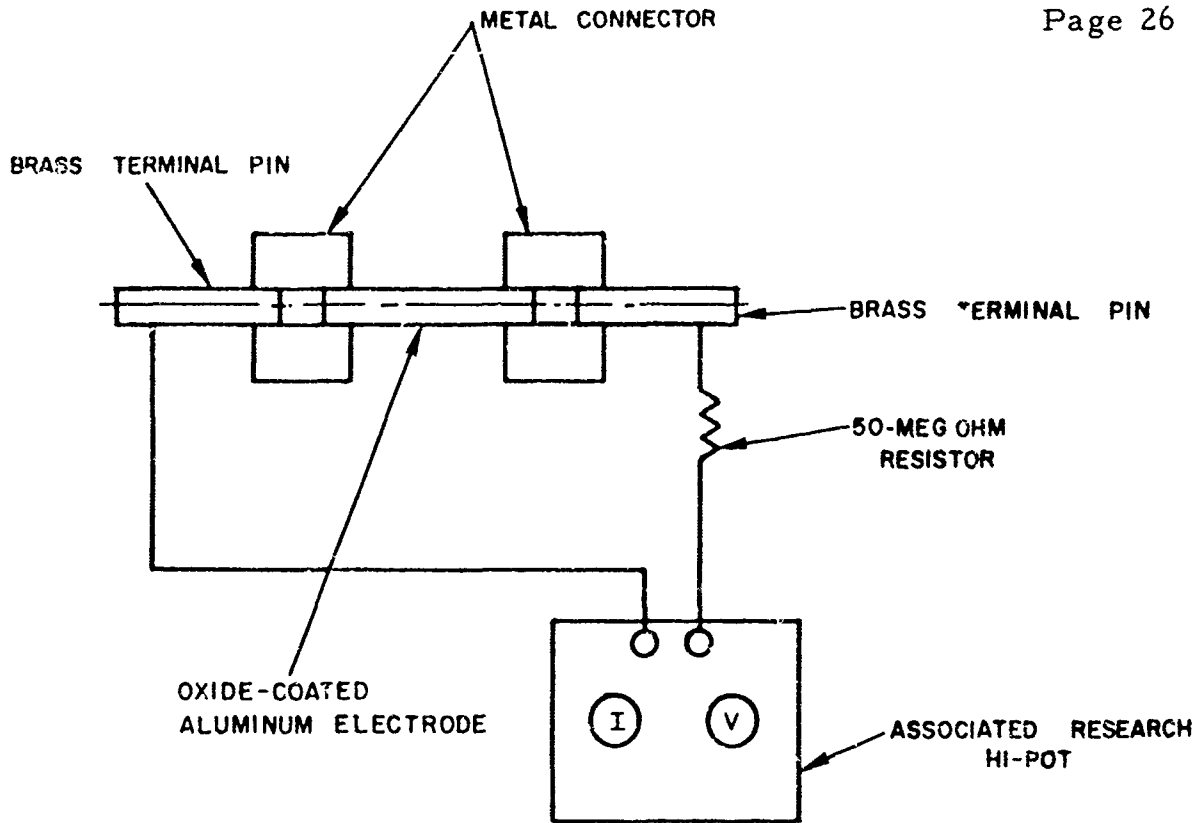

Figure 11. Test Header with Aluminum-Oxide Coated Terminal, and Instrumentation to Monitor Voltage Breakdown.

Table 4. Voltage Breakdown of 0.062-in. Dia Aluminum Electrodes Coated with 2 Mils Aluminum Oxide.

Sample Number	Type of Aluminum Material	Voltage Breakdown (volts)	Current Flow Prior to Al_2O_3 Coa. Breakdown (μa)
1	99% Aluminum (2SO Temper)	800	10
2	↓	750	20
3		750	30
4		700	20
5		750	20
6		99.54% Aluminum (Spec 4043)	600
7	↓	700	20
8		600	20
9		700	30
10		700	30



a. Assembly and Instrumentation for Current Leakage.

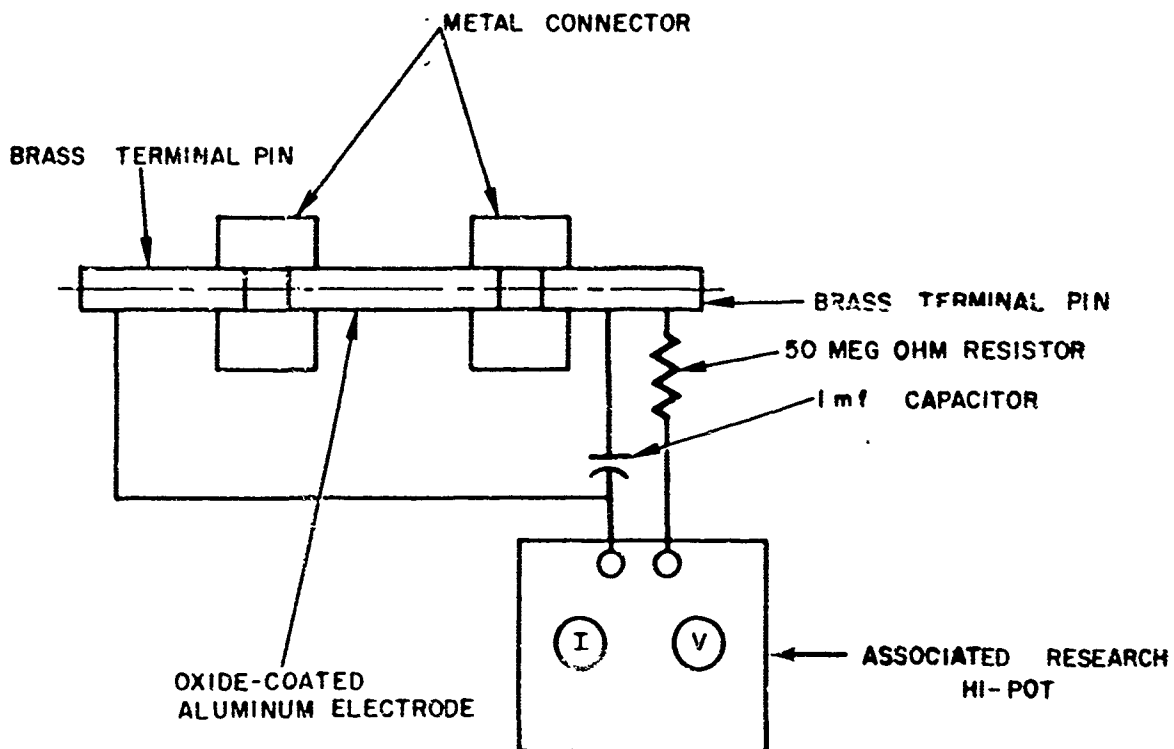

b. Assembly and Instrumentation for Voltage Breakdown.

Figure 12. SOVS Assembly and Monitoring Instrumentation.

conditions of 75 to 82°F at a relative humidity of 44 to 50%. The voltage breakdown of these switches ranged from 1000 to 1050v.

The tests with these aluminum-oxide coated aluminum electrodes indicated that the electrode with 1.5 mil aluminum-oxide coating, assembled as indicated in Figure 12, would meet the voltage breakdown requirements of the EBW initiator at ambient conditions.

3.2 ELECTRICAL CHARACTERISTICS OF SOVS INITIATORS

3.2.1 Tests at Ambient

To further evaluate the electrical characteristics of the SOVS utilizing the aluminum-oxide coated aluminum electrode, engineering and prototype model voltage switch initiators were assembled with a 2-mil aluminum-oxide coated aluminum electrode as shown in Figure 13.

When high voltage is applied to the engineering model SOVS initiator assembly, shown in Figure 13a, the current will flow through the metal adaptor (a-2) into the brass sleeve connector (a-3) through the aluminum-oxide coating and into the aluminum electrode (a-1). From the aluminum electrode, the current will flow through the aluminum-oxide coating into the metal connectors (a-11, a-10, a-9) into the stainless steel tube (a-8) to the bridgewire (a-5), and then to ground, completing the circuit.

When high voltage is applied to the prototype SOVS initiator assembly, the current will flow through the switch as shown in Figure 13b. The current will flow through the metal terminal pin (b-11), into the Kovar metal sleeve (b-9), into the copper sleeve (b-5), through the aluminum-oxide coating, into the aluminum electrode (b-6), through the aluminum-oxide coating into the copper sleeve (b-4), and into the Kovar sleeve (b-2) to the bridgewire (b-1) and to ground.

The test instrumentation shown in Figure 14 was used to monitor the engineering model and the prototype SOVS initiator assemblies for the initial, repetitive, and 24-hr voltage breakdown characteristics, and for current vs time waveshapes. A coaxial Park shunt was used to record the discharge current-time history of the exploding bridgewires of all prototype and engineering model SOVS initiators.

The initial voltage breakdown characteristics of the SOVS initiator units were determined when the 1μf capacitor discharged through the SOVS unit, exploding the bridgewire. The repetitive voltage breakdown tests were performed by pulsing the assemblies four times consecutively with high

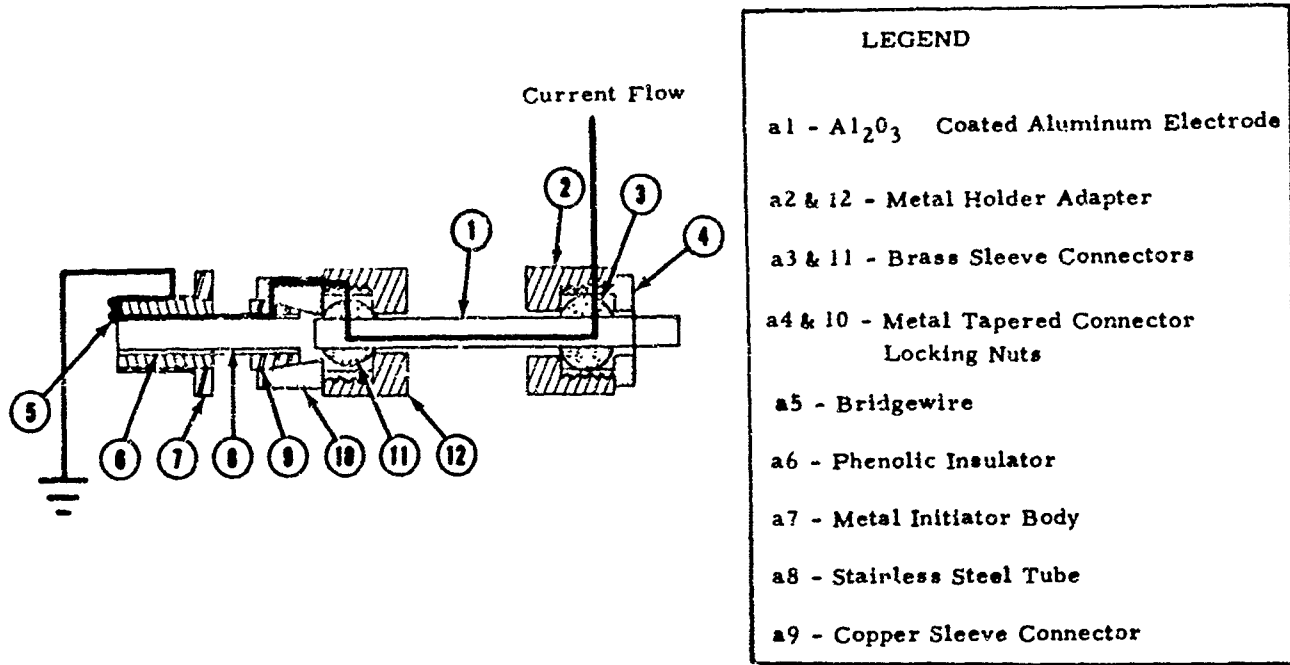

a. Engineering Model Assembly.

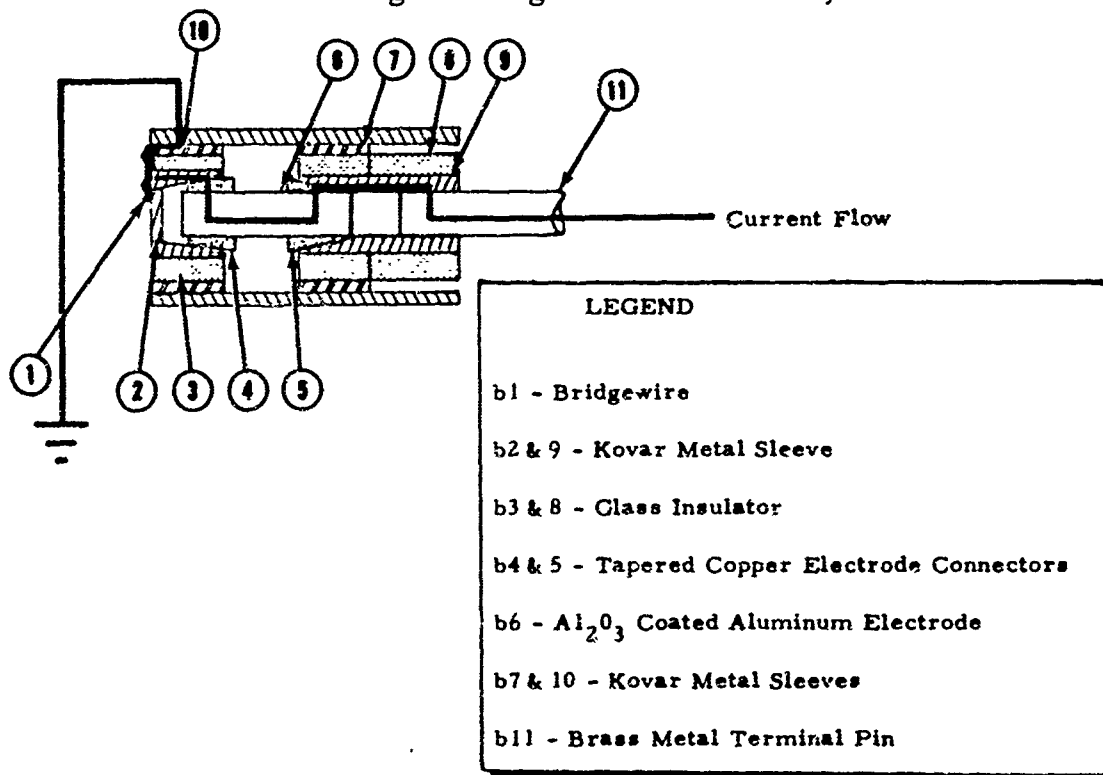

b. Prototype Assembly.

Figure 13. Engineering Model and Prototype SOVS EBW Initiator Assemblies.

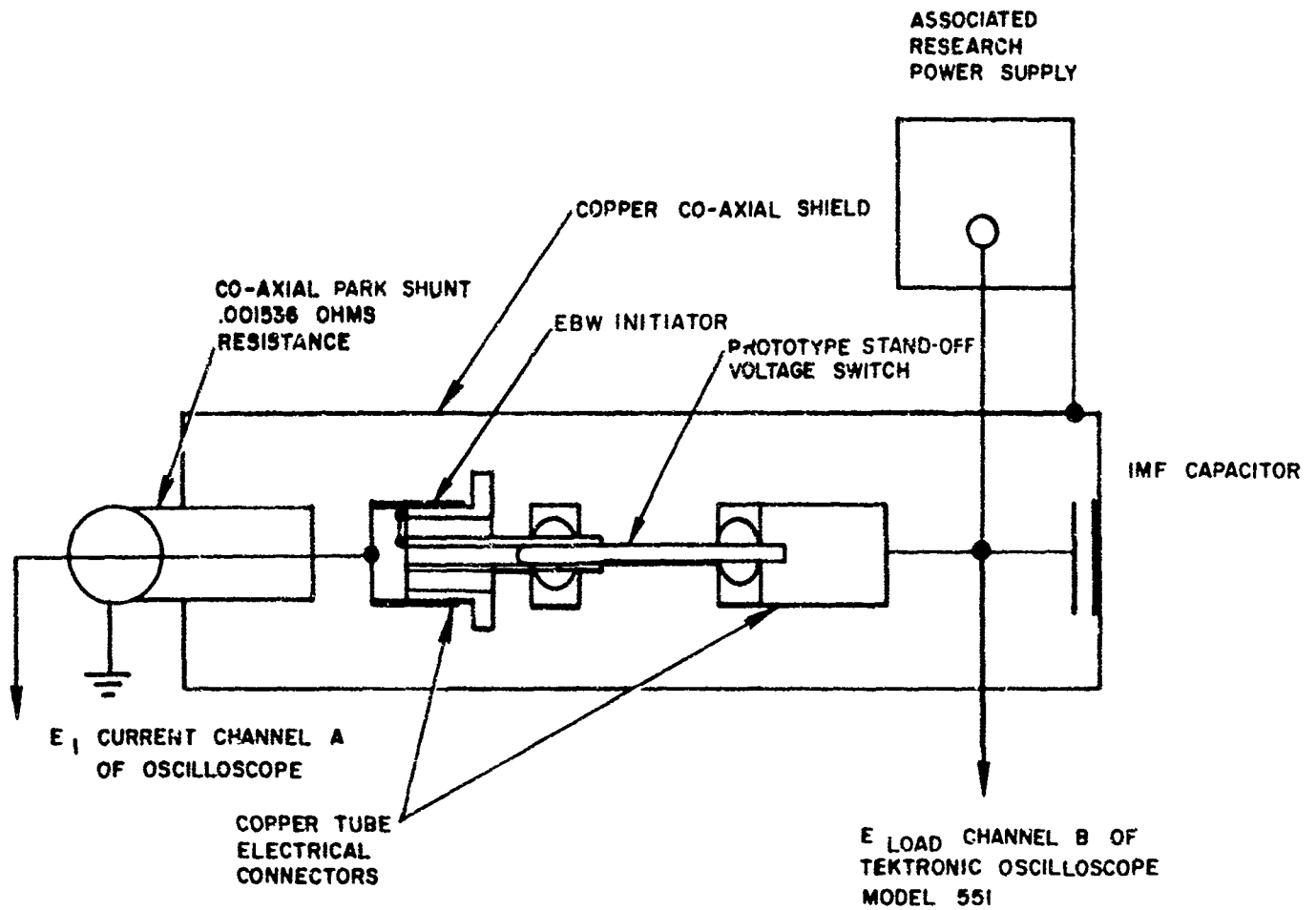

1939-3- -1

Figure 14. Test Instrumentation for Monitoring Voltage Breakdown and Current-Time Waveshapes.

voltages from the $1\mu\text{f}$ capacitor. New bridgewires were provided. The 24-hr recovery tests were performed after 24 hr had elapsed from the initial test.

Tables 5 and 6 present the test data for SOVS engineering models EM-1 and EM-2, respectively. Table 7 shows the test results for SOVS prototype models P-1, P-2, and P-3. These results are shown graphically in Figures 15 (for engineering models) and 16 (for prototype models). In summary, these results indicated that:

- a. The initial voltage breakdown ranged from 900 to 1050 v. (Typical current-time waveshapes of breakdown voltage and current pulse are shown in Figure 17).
- b. Repetitive voltage breakdown tests revealed no degradation of voltage breakdown characteristics.
- c. The first indication of functional degradation of the SOVS was noted in the EM-1 assembly after the ninth consecutive firing. Testing of the prototype assemblies was limited. Prototype P-3 functioned satisfactorily; four pulses produced no degradation.

3.2.2 Effect of High and Low Temperatures

The apparatus and instrumentation of Figure 18 was developed to monitor the electrical characteristics of the SOVS at high and low temperatures while introducing a minimum amount of inductance to the monitoring circuit. The SOVS initiator assemblies in the Delta environmental chamber were shielded with a 6-in. length of 1/2-in. copper tube, and the electrical circuitry extending from the assemblies to the coaxial electrical circuit was also shielded with two 9-in. lengths of 1/4-in. copper tubing. The method used to monitor the current-time waveshapes/and breakdown voltages was similar to that shown in Figure 14.

The prototype initiator assemblies (Figure 19) were final design glass-to-metal seal headers with 2-mil aluminum-oxide coating on 0.0645-in.-diameter aluminum electrodes assembled within the inner Kovar glass-to-metal sleeve. Since the ends of the electrodes were not coated, it was necessary to provide for a 0.015-in. air cavity in the individual headers to prevent arc flashover from the ends of the electrode to the inner Kovar glass-to-metal sleeve. In the P-1 prototype units, this was accomplished by counterboring the inner Kovar sleeve to 0.095-in. while the coated aluminum electrode was assembled into the remaining 0.065-in. ID of the Kovar sleeve. The P-2 prototype model was fabricated with a 0.095-in. ID in the inner Kovar sleeve which was tapered

Table Test Data for Engineering Model No. 1*
SOVS Initiator Assemblies.

Sample	Initial Voltage Breakdown (v)	Repetitive Voltage Breakdown (v)	24-hr Recovery Voltage Breakdown (v)	Current at Bridgewire (amp)	Time to Peak Current (μ sec)
1	950			800	0.6
2		900		780	0.6
3		875		732	1.5
4			600	532	0.6
5			850	800	0.6
6**			900	1332	0.8
7			800	732	0.6
8**			700	928	0.8
9**			600	732	0.8

* Engineering Model No. 1 has EBW initiator switch of the 2.0 mil aluminum-oxide coated aluminum electrode series, assembled 30 November 1961. Sample 3 bridged with 0.5 mil Tophet C. Samples 1, 2, 4, 5, and 7 bridged with 2.0 mil platinum-iridium 90/10 alloy bridgewire.

** No bridgewire; header shorted.

Table 6 Test Data for Engineering Model No. 2*
SOVS Initiator Assemblies.

Sample	Initial Voltage Breakdown (v)	Repetitive Voltage Breakdown (v)	24-hr Recovery Voltage Breakdown (v)	Current at Bridgewire (amp)	Time to Peak Current (µsec)
1	900			732	0.60
2		925		765	0.60
3		850		666	0.60
4		800		600	0.58
5		1100		732	0.60
6			900	732	0.60
7			900	732	0.60
8			1000	800	0.60

* Engineering Model No. 2 has EBW initiator switch of the 2.0 mil aluminum-oxide coated aluminum electrode series, assembled 6 December 1961. All test samples bridged with 2.0 mil platinum-iridium 90/10 alloy bridgewire.

Table 1 Test Data for Prototype SOVS Initiator Assemblies.

Prototype* SOVS Initiator Assembly	Initial Voltage Breakdown (v)	Repetitive Voltage Breakdown (v)	24-hr Recovery Voltage Breakdown (v)	Current at Bridgewire (amp)	Time to Peak Current (µsec)
P ₁	975	950		800	0.6
		600		800	0.6
				600	0.6
P ₂	950	950		732	0.8
		1050		732	0.8
		900		**	---
		800		**	---
P ₃	1050			750	0.8
				750	0.8
				**	---
			1000	750	0.8
			1000	**	---
			1000	750	0.8

* All assemblies bridged with 2.0 mil platinum-iridium 90/10 alloy bridgewire.

** No oscilloscope trace.

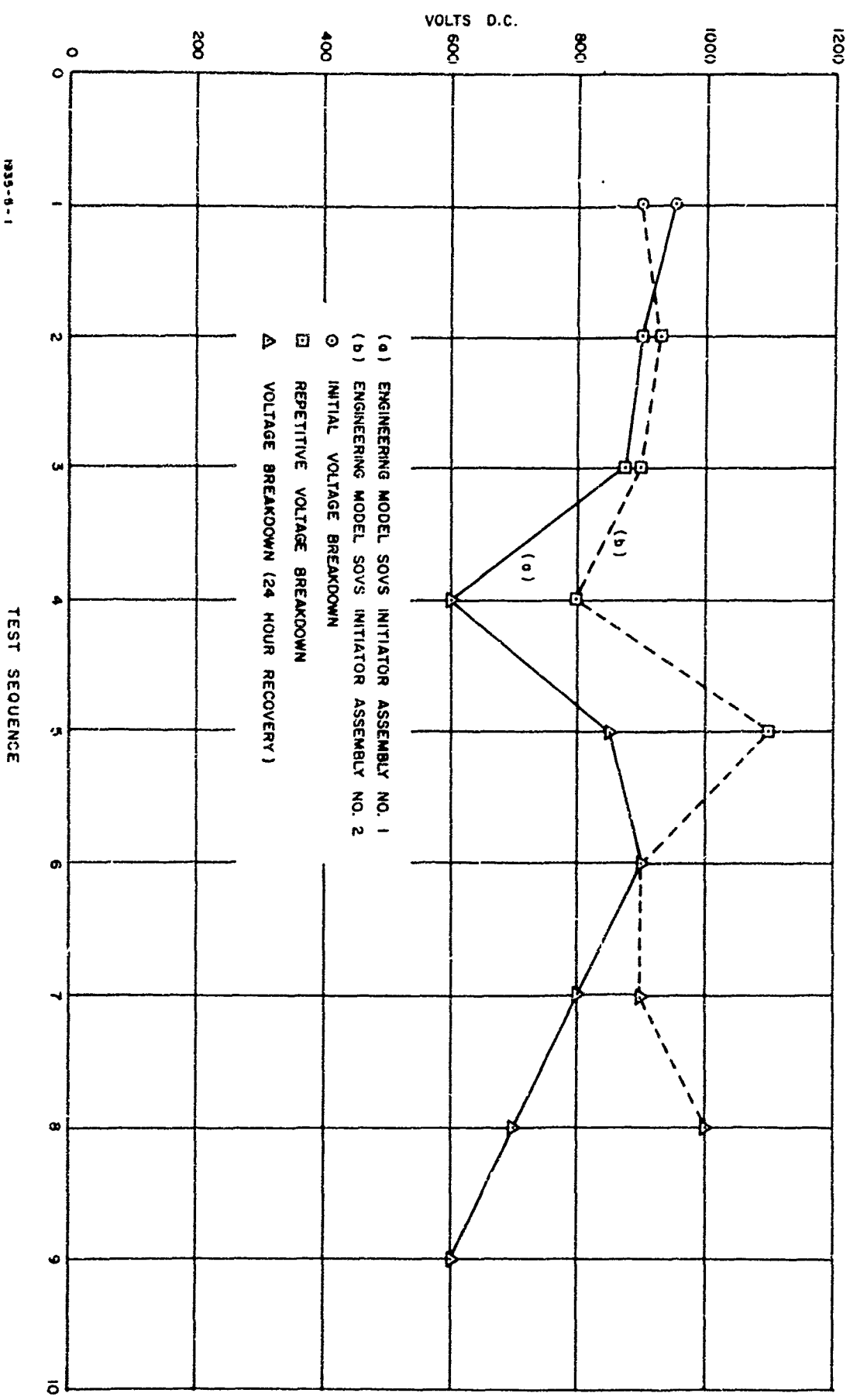

Figure 15. Voltage Breakdown Characteristics of Engineering Model Initiator Assemblies.

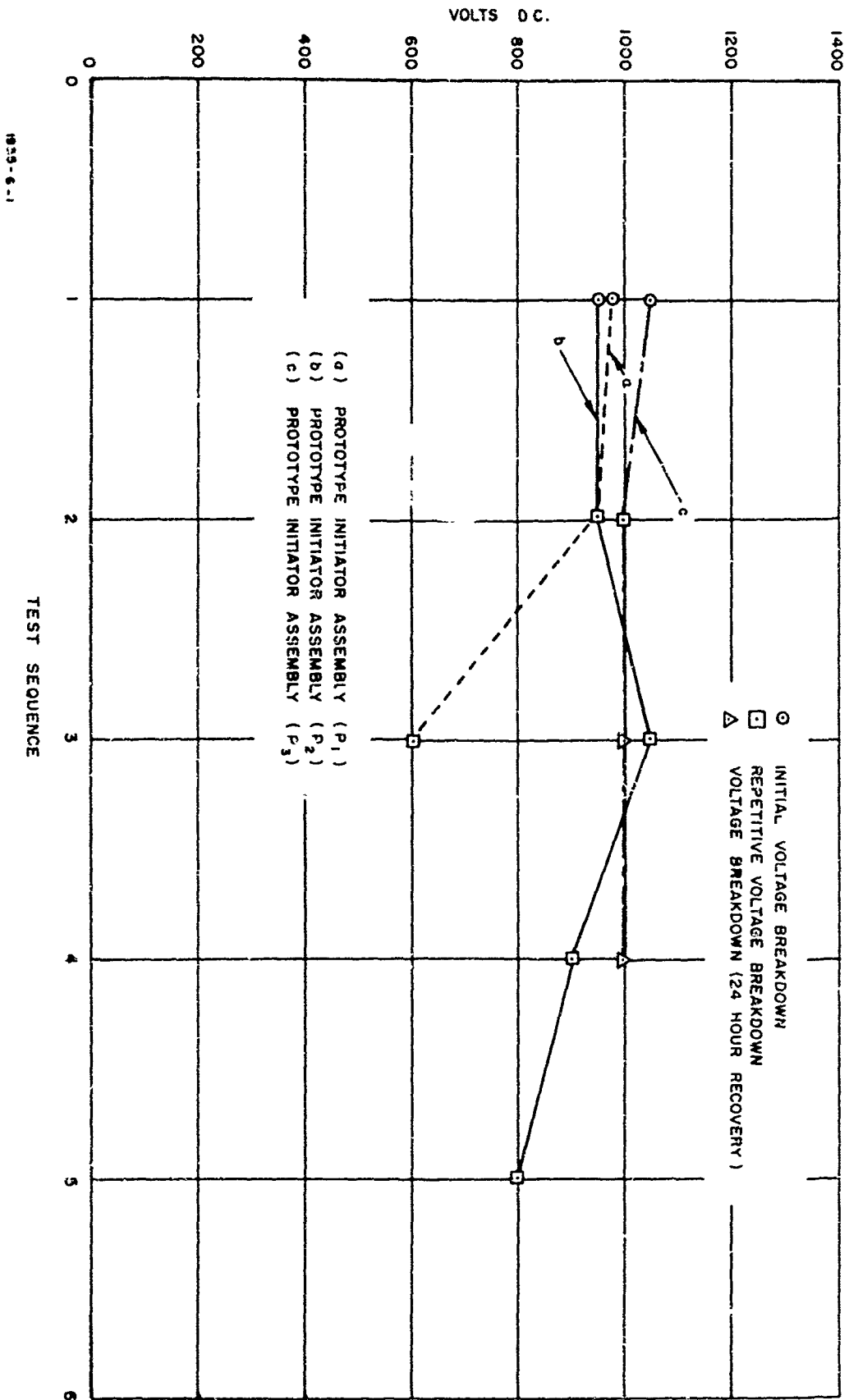
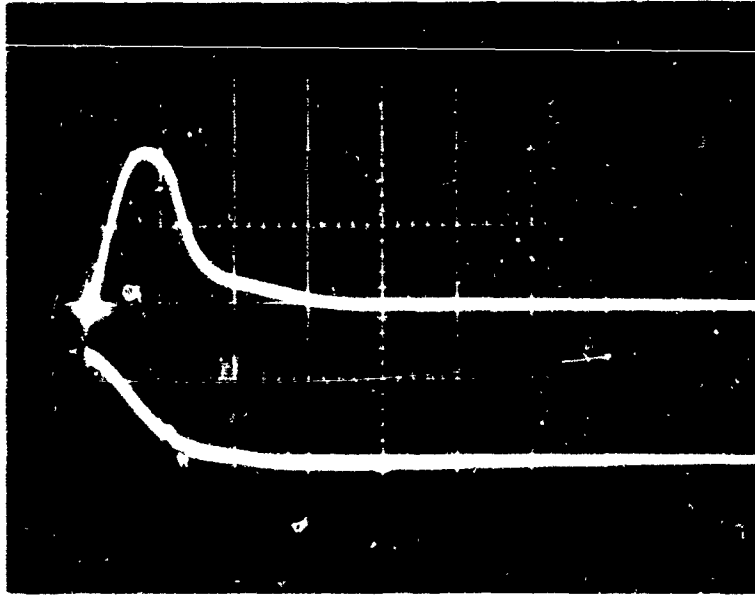

Figure 16. Voltage Breakdown Characteristics of Prototype Initiator Assemblies.



Legend

Upper Trace: Current at 333 amp/cm
Lower Trace: Voltage at 500 v/cm
Time Scale: 1 sec/cm

Results

670 amp Peak
700 v*
0.8 sec to peak current

*Breakdown voltage was monitored by a voltmeter while the 1- μ f capacitor was being charged slowly. The scope was triggered by the current pulse of the SOVS breakdown. At the moment of breakdown, the capacitor voltage was 950 v. The voltage of the capacitor dropped from 950 to 700 v at the time the current pulse triggered the scope.

Figure 17. Typical Waveshape of Voltage Breakdown Characteristics.

Figure 19 Prototype Models, SOVS Initiator Assemblies.

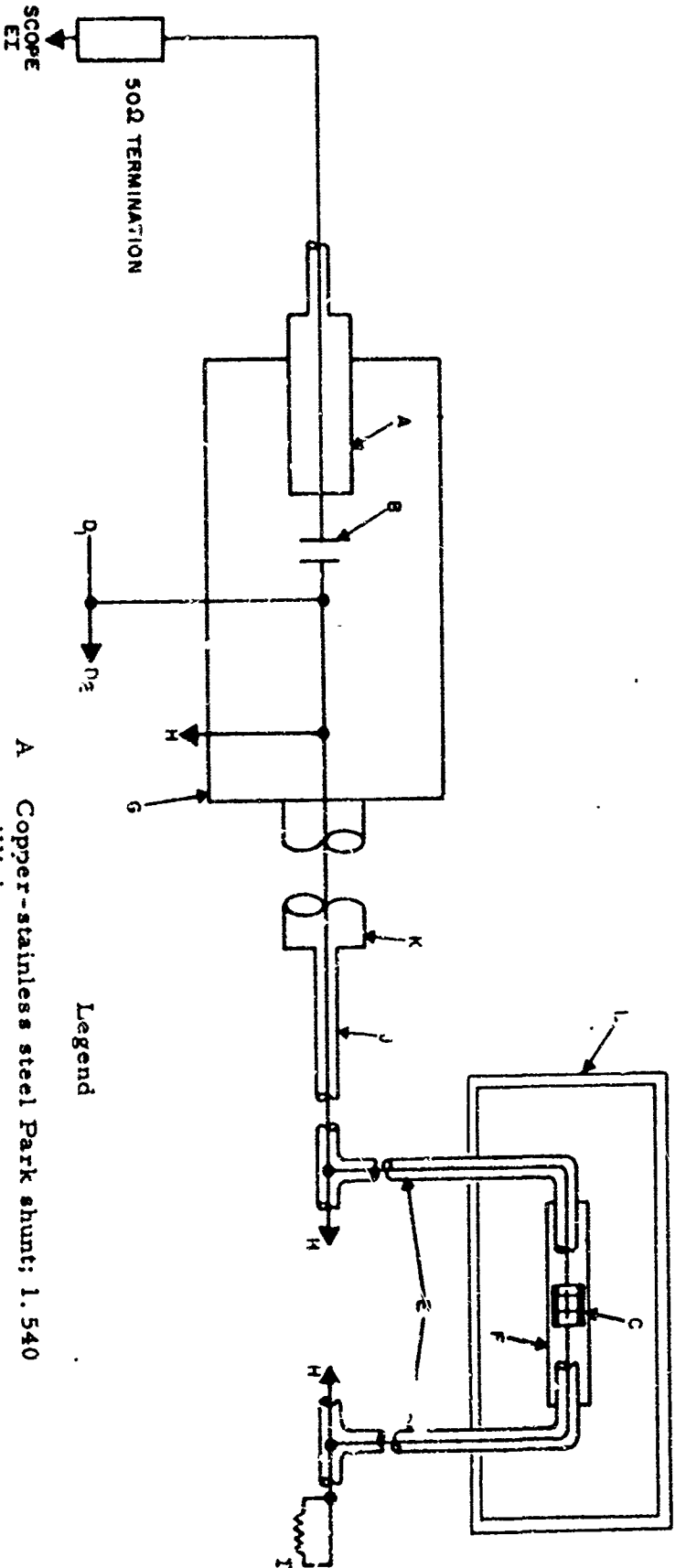

- Legend
- A Copper-stainless steel Park shunt; 1.540 milliohm
 - B Plastic capacitor; pulse; 1 μf, 2 kv+
 - C SOVS Initiator assemblies
 - D1 Associated Research Hipot Model 421, 0-10 k, 500 ma
 - D2 Capacitor input monitor; Keithley 210 w/2007, 1006.1 divider
 - E High temperature line, 9 in. of 1/4-in.-dia tubing with Teflon wire adapt to UHF
 - F Copper (1/8-in.-dia) tubing with 40 mil pin and socket to SOVS header assembly
 - G Copper coaxial firing unit with HV connector to RG8 to UNF connector
 - H High voltage probe, 1000-1 Tektronix 5015
 - I Load resistor (RL) on BNC to UHF connector
 - J Two ft RG8 coaxial connector
 - K HN connector
 - L Delta environmental chamber

1938-0-1

Figure 18. Block Diagram of Instrumentation to Test Effects of High and Low Temperatures on SOVS.

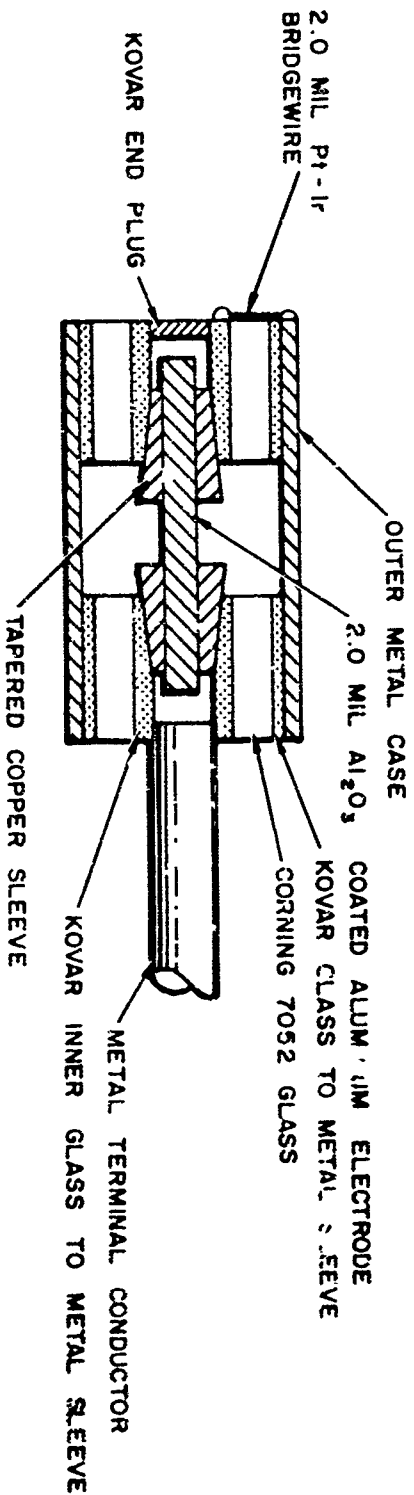
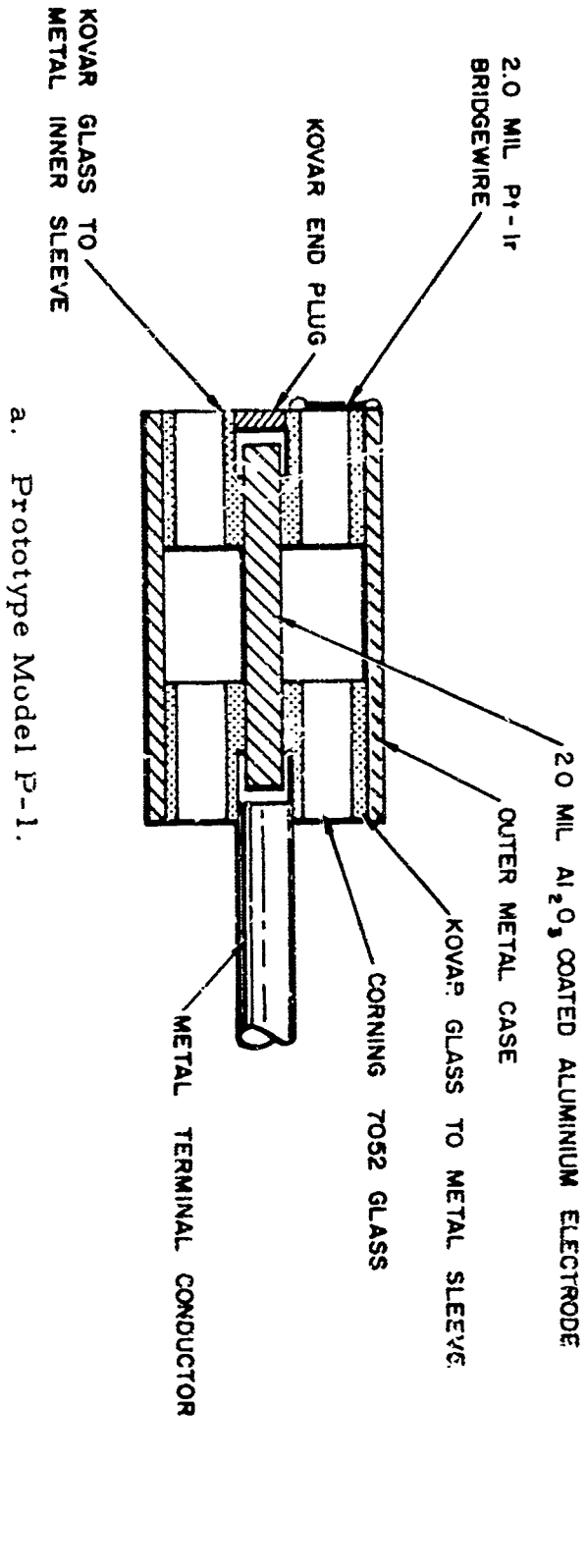

at one end to receive tapered copper sleeves into which the electrode was assembled.

Tables 8 and 9 present the voltage breakdown characteristics of the prototype initiators that were exposed to +350°F and -65°F in the Delta environmental chamber.

The average voltage breakdown values of the assemblies exposed to +350°F was 11% lower than room temperature values, while the values at -65°F were 9% higher.

3.2.3 Effects and Efficiency of the SOVS Initiator Assembly in EBW Circuitry

The effects of the SOVS initiator assembly on the exploding bridgewire circuitry were determined by comparing the current-time waveshapes of the conventional EBW circuitry (i. e., without the SOVS) with that of the final design prototype SOVS initiator assembly (Figure 20). Both tests used a 1-ohm coaxial load resistor. Other load resistors were also introduced in the EBW electrical circuitry of Figure 21. The NOL SK 204 6135 EBW Firing Unit was used to supply the high voltage pulse for firing the EBW initiator assemblies under study. The peak current measurements, when $R_L = 1$ ohm, indicated that the times to the current peaks were identical. The magnitude of the peak current pulse with the SOVS in the circuit was 4% less than the peak current without the SOVS. The efficiency of energy transfer, based on peak current measurements, was 91%. The following data illustrates, in summary, the current transfer efficiency of the SOVS when incorporated in an exploding bridgewire circuit.

Thickness of Aluminum Oxide Coating (mil)	Load Resistor R_L (ohms)	Peak Current Measurements		Current Difference (%)	Efficiency of Energy Transfer (%)
		Without SOVS (amps)	With SOVS (amps)		
2.0	1.0	1,120	1,075	4	91
2.0	0.1	1,650	1,450	12	78
2.5	0.1	1,650	1,400	15	72

Table 8. Voltage Breakdown Characteristics of Prototype Model
SOVS Initiator Assemblies at High Temperature (+ 350 °F).

SOVS Prototype Model EBW Initiator Assembly	Initial Voltage Breakdown (v)	Repetitive Voltage Breakdown (v)	Peak Current (amp)	Time to Peak Current (μsec)
P1 Sealed	800		480	0.8
		850	550	0.8
P2 Sealed	950		700	0.8
		550	400	0.8
		450	333	0.8
		600	366	0.8
		575	*	
P2 Sealed	1000		600	0.8
	975		580	0.8

* No oscilloscope trace.

Table 9. Voltage Breakdown Characteristics of Prototype Model* SOVS Initiator Assemblies at Low Temperature (-65°F).

Sample	Initial Voltage Breakdown (v)	Repetitive Voltage Breakdown (v)	Peak Current (amp)	Time to Peak Current (μsec)
1	1150		650	0.75
2		1100	700	0.75
3		950	620	0.80
4		1050	600	0.75
5		950	600	0.75

* Model P₁ with 2.0 mil platinum-iridium (90/10) alloy bridgewire; unit not hermetically sealed

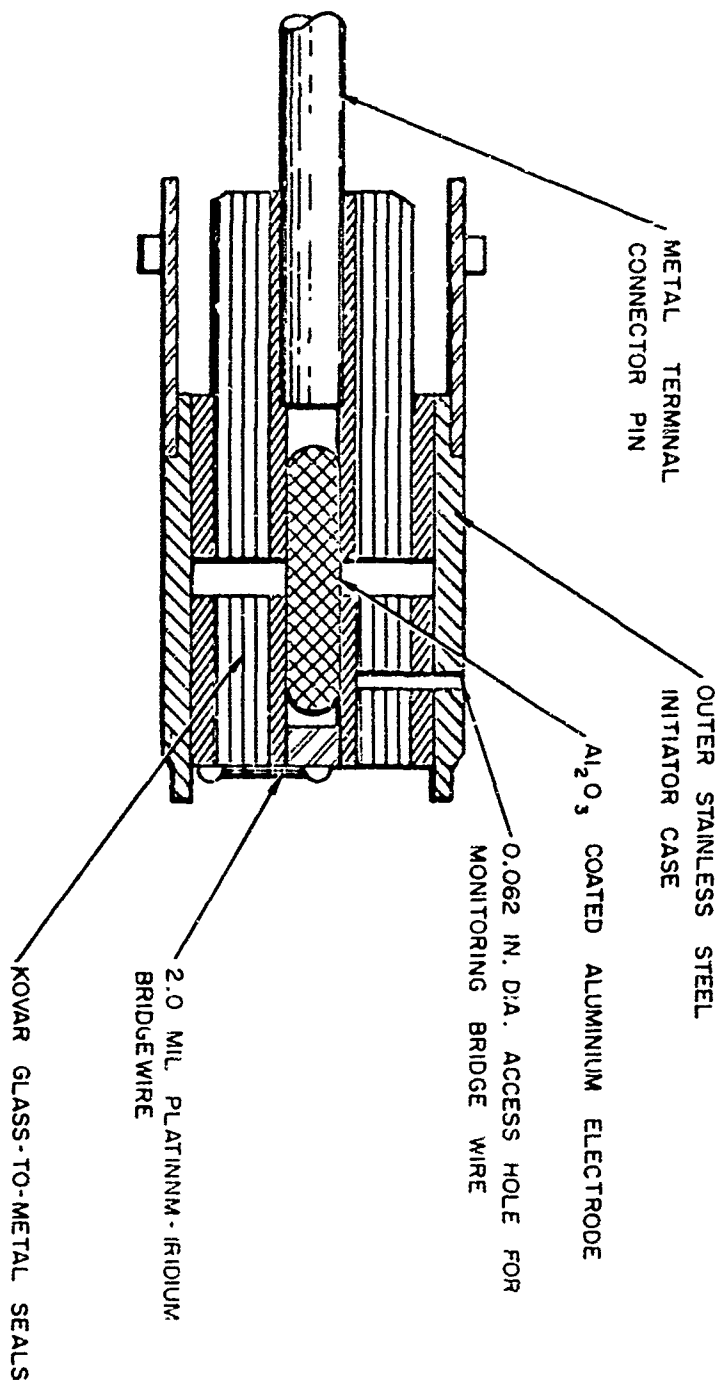

1935-6 - 1

Figure 20. Final Design, Prototype SOVS Initiator Assembly.

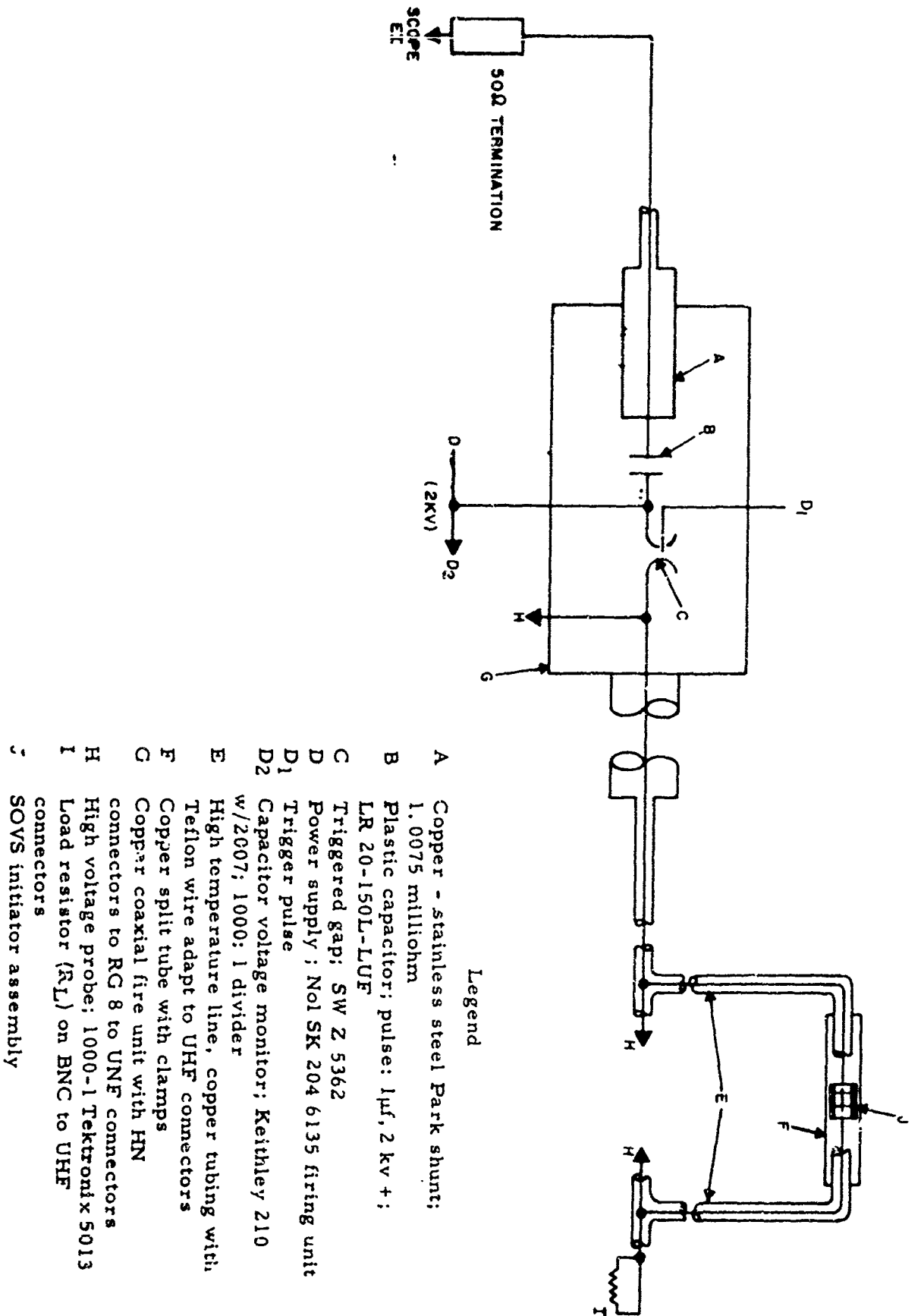

Legend

- A Copper - stainless steel Park shunt; 1.0075 milliohm
- B Plastic capacitor; pulse: 1μf, 2 kv + ; LR 20-150L-LUF
- C Triggered gap; SW Z 5362
- D Power supply ; Nol SK 204 6135 firing unit
- D1 Trigger pulse
- D2 Capacitor voltage monitor; Keithley 210 w/2007; 1000; 1 divider
- E High temperature line, copper tubing with Teflon wire adapt to UHF connectors
- F Copper split tube with clamps
- G Copper coaxial fire unit with HN connectors to RG 8 to UNF connectors
- H High voltage probe; 1000-1 Tektronix 5013
- I Load resistor (RL) on BNC to UHF connectors
- J SOVS initiator assembly

Figure 21. Block Diagram of Instrumentation to Test Effects of SOVS in EBW Circuit.

Previous tests indicated that a substantial change in oxide thickness would appreciably change the stand-off voltage characteristics, but the above data shows that oxide thickness changes do not appreciably affect the energy transfer efficiency.

3.2.4 Effect of a Resistor in Parallel with SOVS

The effects of introducing a 270 k ohm resistor in parallel with the SOVS (Figure 22) were determined by pulsing 2000 v from the 1- μ f capacitor into the circuitry and observing the current-time waveshapes. No appreciable effect on the current-time waveshapes was observed.

3.2.5 Effect of SOVS in Series and Parallel in the EBW Circuit

The effects of introducing SOVS exploding bridgewire initiators in series and parallel in the exploding bridgewire circuitry were studied. Two prototype SOVS initiator assemblies were introduced at J in Figure 23. Measurements of peak current were taken as the circuit was pulsed with 2000 v from a 1- μ f capacitor.

With two prototype SOVS initiators connected in parallel, the peak current was approximately 8% less than that obtained with no SOVS in the circuit. With one SOVS in the circuit, peak current was 12% less than that with no SOVS in the circuit. Two SOVS in series in the circuit gave 25% less peak current than that with no SOVS in the circuit.

Comparing the differences in peak current measurements of two SOVS units in series and two in parallel with respect to one SOVS unit indicates:

- a. Addition of the second SOVS in series reduces the capacitor discharge peak current by an additional 13%.
- b. Addition of the second SOVS in parallel results in the total capacitor discharge peak current being increased by 4%.

3.3 EVALUATION OF PROTOTYPE GLASS-TO-METAL SEAL HEADERS

Final design prototype glass-to-metal seal headers, shown in Figure 24, were evaluated for pin-to-case voltage breakdown performance and pin-to-case resistance. Table 10 represents the results of the pin-to-case voltage breakdown, first indication of current leakage from pin

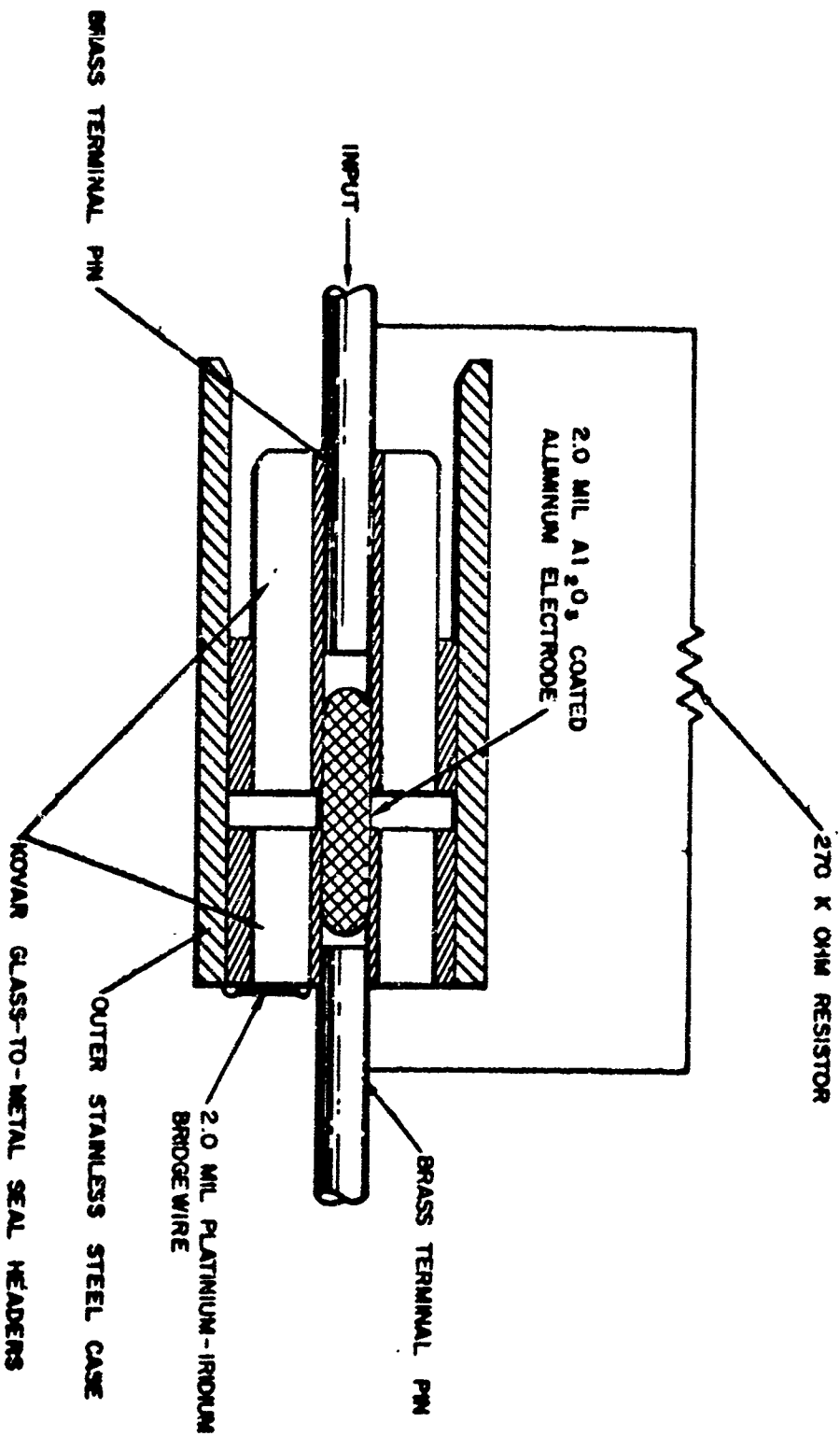

1985-6 - 1

Figure 22. Prototype SOVS Assembly with 270 k ohm Resistor in Parallel.

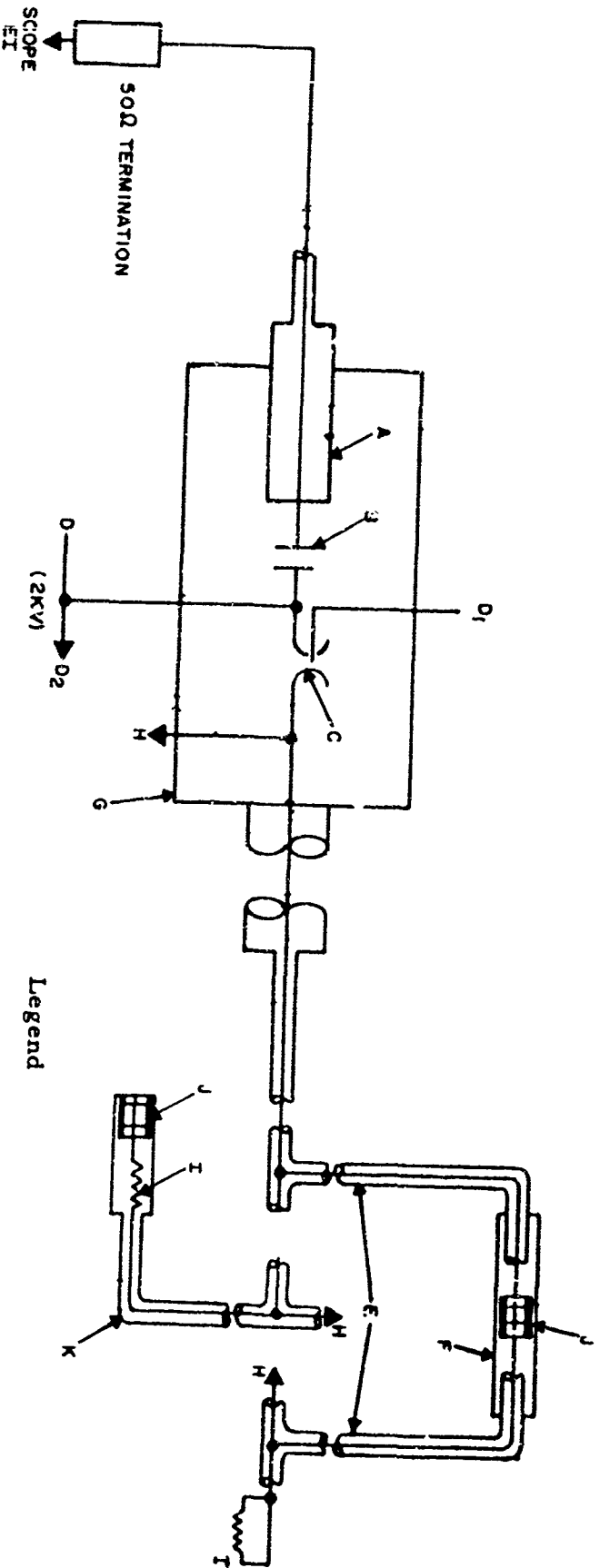

Legend

- A Copper-stainless steel Park shunt; 1.0075 milliohm
- B Plastic capacitor; pulse: 1 μf, 2 kv+; LR 20-150 L-LUF
- C Triggered gap, SW Z 5362
- D Power supply, null fire unit modified
- D1 Trigger pulse for null firing unit
- D2 Capacitor input monitor, Keithley 210 w/2007; 1000: 1 divider
- E High Temperature line; copper tubing with Teflon wire to adapt to UNF; 2.5 ft
- F Copper split tube with clamps outer conductor with 40 mil pin and socket connector to sample
- G Copper coaxial fire unit with HN connector to RG8 to UNF connectors
- H High voltage probe 1000-1 Tektronix 5013
- I 0.17 ohm manganin load resistors
- J SOVS prototype initial assemblies
- K 2.5 ft of RG-59 coaxial cable

Figure 23. Block Diagram of Instrumentation Used with Initiator in Series and in Parallel with EBW Circuit.

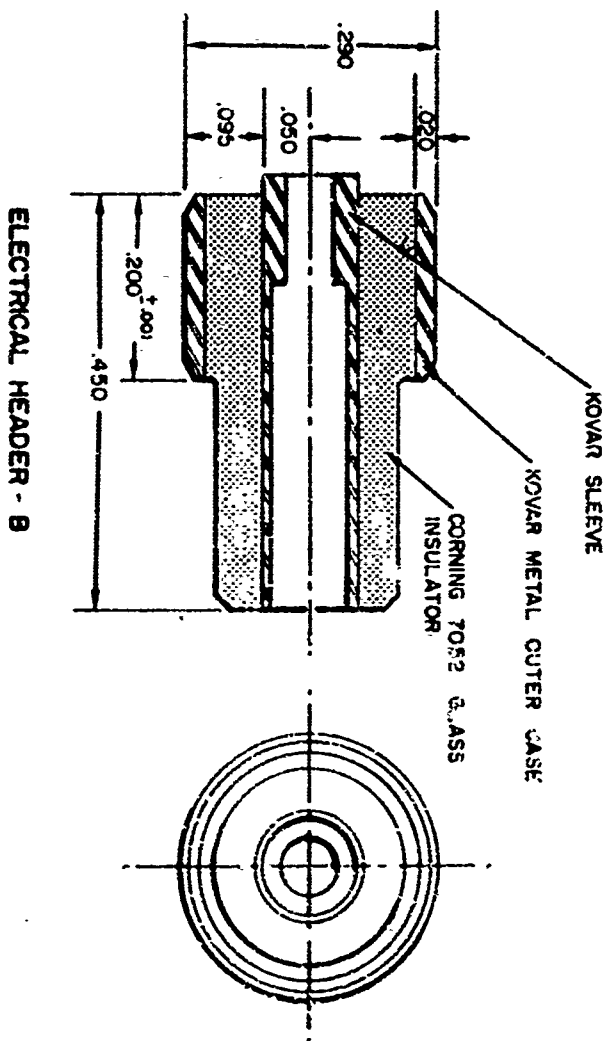
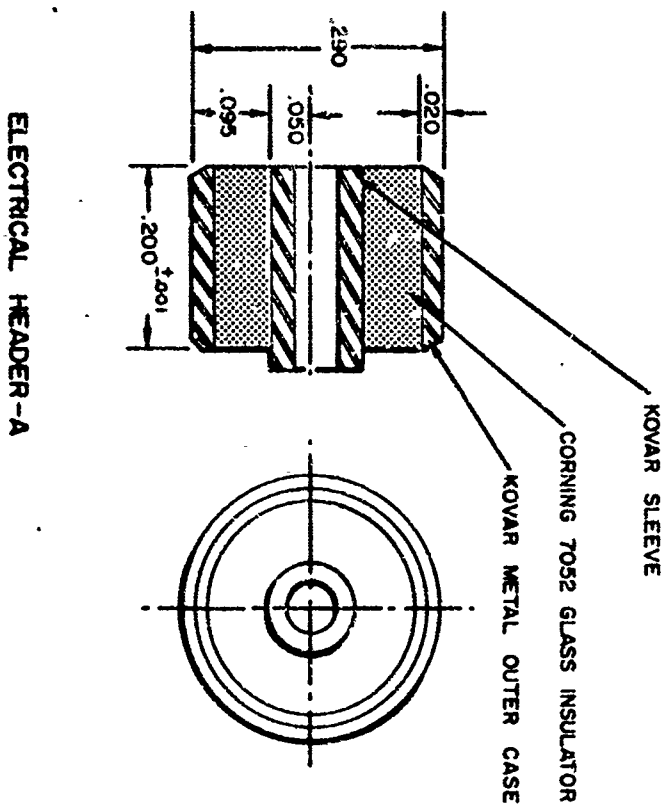

1955-6-1

Figure 24. Final Design, Prototype Glass-to-Metal Seal Headers.

Table 10. Test Data for Prototype SOVS Glass-to-Metal Seal Headers.

Prototype Header Sample	Pin-to-Case Voltage Breakdown (kv)	Current at First Indication of Voltage Breakdown (nanoamp)	Calculated ($I = E/R$) Pin-to-Case Resistance (teraohm)	Pin-to-Case Arc Flashover Voltage (kv)
1 A	3.0	0.10	30	4.0
2 A	3.0	0.05	60	4.0
3 A	3.0	0.05	0.5	3.2
4 A	4.5	0.05	80	6.0
5 A	3.0	0.03	100	4.7-5.5
6 A	3.0	0.10	30	3.6
7 B	3.0	2.0	1.5	4.0
8 B	3.0	4.0	0.7	4.2
9 B	3.0	3.0	1.0	3.2
10 B	3.0	6.0	0.5	4.1
11 B	3.0	3.0	1.0	4.8
12 B	3.0	5.0	0.6	4.2

to case, and pin-to-case flashover voltage.

The pin-to-case voltage breakdown of the headers tested met the 3000-v requirement of Reference 1. In addition, the electrical header flashover voltage ranged from a minimum of 3.2 kv to the maximum of 6.0 kv.

The pin-to-case resistance of the electrical headers ranged from 1.5 to 100 teraohms. These values were calculated using Ohm's Law. The current values used in these calculations were obtained by monitoring the steady state current with a Keithley microammeter at the pin-to-case voltage breakdown for each of the electrical headers.

3.4 MONITORING BRIDGEWIRE CONTINUITY

The continuity of the bridgewire circuit of the SOVS initiator assembly may be, by the very nature of its design, monitored by two methods:

- a. The conventional method by inserting one probe of the ohmmeter into the 0.062-in. -diameter access hole provided in the SOVS header assembly as shown in Figure 20 and connecting the second probe to the case.
- b. The current-leakage method by applying 500 v and monitoring the current leakage. The leakage current through these assemblies with 1.5-to 2.0-mil aluminum-oxide coatings was approximately 0.1 μ a with 500 v applied. This test, which also indicates that the unit has a satisfactory stand-off voltage, is valid only if the unit has been properly cleaned and assembled, and if the leakage current measured is that through the oxide coating only.

4. CONCLUSIONS

The investigations to include a stand-off gap switch (SOGS) within the electrical header of an exploding bridgewire initiator have established the design criteria (such as, the materials utilized for the fabrication of the voltage switch, electrode geometrical configuration, spacing of the electrodes within the electrical header, voltage switch, and initiator header dimensional parameters) and reproducibility of assembling the voltage switch initiators.

The test evaluation studies of the SOGS initiator assemblies indicated that these engineering models had limited electrical performance capabilities when exposed to high altitude and temperature conditions.

The design philosophy of the SOGS initiator header was changed from the three-pin-terminal header design of NOLC TM 55-80 to that of the single central electrode design as shown in Figure 10. This design not only proved versatile in reproducibility of the SOGS within the electrical header but also provided a method of connecting the initiator assembly to a coaxial connector design for high altitude electrical performance.

From studies of voltage breakdown characteristics of hermetically sealed SOGS initiator assemblies, it was found that the variation in the voltage breakdown was approximately 500 v when exposed to temperatures from room temperature to +350°F. This variation in voltage breakdown characteristics was dependent upon the product of the gas pressure and the separation of the electrodes. Investigations to reduce this variation led to the studies of a voltage switch which does not utilize the gas pressure and electrode separation properties for its electrical breakdown mechanism.

It was determined, in development and test evaluation studies, that the stand-off voltage switch (SOVS) utilizing the controlled dielectric breakdown of a thin aluminum oxide film (1.5- to 2.0-mil thick) formed electrically on the 0.062-in. diameter aluminum electrode, did not exhibit the variations in breakdown voltage when subjected to the specified temperature extremes. When assembled with an EBW initiator unit, all electrical safety and functional requirements were met.

The studies of the effects of the SOVS initiator assembly, when inserted in circuitry, disclosed that the energy transfer efficiency was approximately 78% when using a bridgewire load or a load having equivalent resistance. The feasibility of exploding two bridgewires by introducing the SOVS in series and in parallel in the EBW circuitry has also been demonstrated.

Reproducibility of the oxide-coated aluminum electrode SOVS within the exploding bridgewire initiator unit has been established. The simplicity of the SOVS assembly, which basically consists of four component parts, makes it relatively easy to assemble. The design of this voltage switch is unique in that:

- a. It eliminates the introduction of air or inert gas or plastic materials within the switching cavity. Air, inert gas, or plastic materials within the switch cavity adversely affect the voltage breakdown characteristics when the voltage switch assemblies are subjected to temperatures ranging from -65°F to +350°F.

- b. The thinly coated aluminum electrode is assembled into the switching cavity in such a manner that it is in physical contact with the metal conductor of the EBW header unit; therefore, the unit is more resistant to shock and vibration environments.

- c. It is possible to design an exploding bridge electrical header assembly with any desired characteristics by specifying the cross section, the aluminum-oxide thickness, and the sequential combinations of the coated aluminum electrodes.

REFERENCES

1. NOLC Design Objectives and Requirements for Special Electrical Headers for use in EBW Initiators, Appendix A to General Contract Requirements for NOLC Purchase Requisition 62738-1-0450 AO.
2. Physics, Volume 5, December 1934.
3. Feasibility Study of a Stand-off Gap Switch in EBW Initiator, Aerojet-General Corporation Progress Reports:
 - a. Report 0539-01(01)MP, August 1961
 - b. Report 0539-01(02)MP, September 1961
 - c. Report 0539-01(03)MP, October 1961
 - d. Report 0539-01(04)MP, November 1961
 - e. Report 0539-01(05)MP, December 1961
4. High Altitude Problems with Electrical Connectors, Bendix Aviation Corp., Scientific Division, Technical Report 602, Sidney, New York.
5. Meek, J. M., and Craggs, J. D., Electrical Breakdown of Gases, Oxford at the Clarendon Press, 1953.
6. Shand, C. B., Glass Engineering Handbook, 2nd ed., McGraw-Hill 1958.
7. T. J. Williams, SCTM 186-59-(14), The Theory and Design of the Triggered Spark Gap.
8. Park, John H., Shunts and Inductors for Surge Current Measurements, U. S. Department of Commerce, National Bureau of Standards, Research Paper, RP 1823, Volume 39, September 1947.
9. Dushman, S., Vacuum Technique, John Wiley and Sons, 1958.
10. Heyer, R. H., Engineering Physical Metallurgy, D. Van Nostrand.
11. Otley, K. O., Shoemaker, R. F., and Franklin, P. J., "A Voltage Sensitive Switch", Proceedings of I.R.I., October 1958.

12. Edels, H., "Properties and Theory of Electric Arc", The Institution of Electrical Engineers, February 1961.
13. Schmitt, R. W., "Thin Films", International Science and Technology, February 1962.
14. Tucker, T. J., and Neilson, F. W., "The Electrical Behavior of Fine Wires Exploded by a Coaxial Cable Discharge System," Sandia Corporation reprint Report SCR-92 TID 4500 14th Ed. Physics and Mathematics.
15. Tucker, T. J., "Possible Explanation of the Current Density - Dependent Resistivity of Exploding Wires", Journal of Applied Physics, Vol. 30, No. 11, 1841-1842, November 1959.
16. Andersen, G. W. and Neilsen, F. W., "Use of the Action Integral in E. W. Studies," Sandia Corporation reprint, Report No. SCR-94 TID 4500 14th Ed., Physics and Mathematics.
17. Tucker, T. J., "Square-Wave Generator for the Study of Exploding Wires," The Review of Scientific Instruments, Vol. 31, No. 2, 165-168, February 1960.
18. Moore, P. W., Sumner, J. F., Wyatt, R. M., "The Electrostatic Spark Sensitiveness of Initiators," Part 1: "Introduction and Study of Spark Characteristics", Ministry of Supply, Explosives Research and Development Establishment, Report 4R/56.
19. Mather, J. W., and Williams, A. H., "Some Properties of a Graded Vacuum Spark Gap", The Review of Scientific Instruments, Vol. 31, No. 3, March 1960.
20. Maitland, A., "New Derivation of the Vacuum Breakdown Equation Relating Breakdown Voltage and Electrode Separation," Journal of Applied Physics, Vol. 32, No. 11, 2399-2407, November 1961.
21. Moore, P. W., Sumner, J. F. and Wyatt, R. M., "The Electrostatic Spark Sensitiveness of Initiators," Part 2: "Ignition by Contact and Gaseous Electrical Discharges," Ministry of Supply, Explosives Research and Development Establishment, Report No. 5R/56.

22. David, E., "Physical Processes in Electric Wire Explosions," Picatinny Arsenal translation No. 57, October 1960, Translated by U. S. Joint Publications Research Services from Zeitschrift für Physik 150, 162-171, 1958.
23. Coats, A. L., High Altitude Problems with Electrical Connectors, Technical Report 602, Scintilla Division, Bendix Aviation Corporation.
24. Hammond, H. D., Voltage Altitude Problems as Related to Electrical Connectors, Report No. 601, AE Scintilla Division, Bendix Aviation Corporation, Sidney, N. Y.
25. Devins, J. C., and Sharbaugh, A. H., "The Fundamental Nature of Electrical Breakdown," Electro-Technology, February 1961.

APPENDIX A
LIST OF REQUIREMENTS FROM REFERENCE 1

1. REQUIREMENTS

1.1 PHYSICAL REQUIREMENTS

- a. The external configuration of the header shall be as described by the drawing (Figure 3 of this report).
- b. Total leakage through the header must be less than 5×10^{-8} standard cc/sec of helium gas at 15 psi differential pressure.

1.2 ELECTRICAL REQUIREMENTS

- a. Electrical circuitry of the header shall be as schematically represented in Figure 3.
- b. Breakdown potential of the SOGS shall be not less than 450 v nor more than 900 v under all conditions of initial pulse, repetitive pulse, variations of recovery time, temperature (within limits specified below), variations in pulse shape, etc.
- c. The off-resistance (see Figure 3) shall be not less than 50 k ohms nor more than 250 k ohms.
- d. Pin-to-case breakdown potential shall be not less than 3000 v dc at standard temperature and pressure.
- e. The SOGS shall be designed for a maximum attainable efficiency of electrical energy transfer from the discharge of a 1 μ f capacitor charged to 2200 v into a 1-ohm resistive load.

1.3 ENVIRONMENTAL REQUIREMENTS

The header-SOGS system shall be capable of meeting the requirements of the following Military Standard Tests. For purposes of these tests, the term "operable" shall be defined as being capable of meeting all

requirements of Sections 1. 1 and 1. 2; the term "safe" shall be defined as being capable of meeting the minimum requirements of Sections 1. 2 b and c.

- a. Jolt: MIL-STD-300.
- b. Forty-Foot Drop: MIL-STD-302.
- c. Transportation Vibration: MIL-STD-303.
- d. Temperature and Humidity: MIL-STD-304.
- e. Vacuum-Steam-Pressure: MIL-STD-358.

1. 4 GENERAL REQUIREMENTS

- a. The design and methods shall be readily adaptable to mass production techniques.
- b. The design shall have a minimum 5-year shelf life.
- c. First preference in the selection of parts and materials shall be given to those specified in NAVASANDA Publication No. 62. In the case of electronic and electrical parts, those listed in the Armed Services Electro-Standards Agency Publication ASES 49-1 shall also be given first-order preference. If no suitable part or material is listed in these publications, other JAN- or MIL- approved parts shall be considered. In the selection of specific approved parts and materials, preference shall be given to those which are in common use and which are readily available.
 - (1) Metals not inherently corrosion-resistant are to be rendered corrosion-resistant by the application of an approved plating or other surface treatment.
 - (2) Metals used are to be readily soldered and welded or brazed.
 - (3) Dissimilar materials which come in contact must be relatively compatible with regard to corrosion resistance.

- (4) All materials used must be chemically stable when in contact with common explosive materials such as RDX, tetryl, PETN, picrylsulfone, etc., and other common explosive powders which are not listed due to classification of their titles. Further, all materials must have no catalytic effects on these explosive powders.

0539-01(06)FP
Page 58

APPENDIX B

MANUFACTURING DATA FOR EXPLODING
BRIDGEWIRE INITIATOR HIGH VOLTAGE SWITCH

U. S. Navy Contract N123(62738)26854A

APPENDIX B
MANUFACTURING DATA FOR EXPLODING
BRIDGEWIRE INITIATOR HIGH VOLTAGE SWITCH

1. INTRODUCTION

The following describes the manufacturing processes and assembly procedures required to assemble the high voltage switch within the electrical glass-to-metal seal header of an exploding bridgewire initiator. These manufacturing processes and assembly operations must be followed explicitly to insure the desirous electrical functionality of the high voltage switch within the exploding bridgewire initiator assembly.

2. ASSEMBLY OF THE EXPLODING BRIDGEWIRE VOLTAGE
INITIATOR ASSEMBLY

2.1 EXPLODING BRIDGEWIRE VOLTAGE SWITCH
INITIATOR, ASSEMBLY DRAWING P-1001

2.1.1 Component Parts

The following are the component parts necessary for the assembly of the voltage switch initiator assembly:

- a. Glass-to-metal seal header, Drawing 3594 (Figure B-1)
- b. Glass-to-metal seal header, Drawing 3595 (Figure B-4)
- c. Sleeve, Drawing P-1002 (Figure B-2)
- d. Electrical connector, Drawing P-1005 (Figure B-5)
- e. Al_2O_3 coated aluminum electrode, Drawing P-1006 (Figure B-7)
- f. Outer case, Drawing P-1008 (Figure B-10)
- g. Bridgewire
- h. Coaxial connector, Drawing P-1009 (Figure B-9)

2. 1. 2 Assemblies of Initiator Voltage Switch

- a. Exploding bridgewire initiator voltage switch assembly, Drawing P-1001 (Figure B-11)
- b. No. 3594 glass header sleeve assembly, Drawing P-1003 (Figure B-3)
- c. No. 3595 glass header sleeve assembly, Drawing P-1004 (Figure B-6)
- d. Voltage switch electrode header assembly, Drawing P-1007 (Figure B-8)

2. 1. 3 Assembly Procedure for Glass Header Sleeve Assembly 3594

- a. Position the bridgewire across the glass-to-metal seal header and weld the bridgewire to the central terminal post and the edge of the metal outer case of the glass-to-metal seal header, using a capacitor discharge welder. Make certain that the bridgewire is not kinked or stretched during positioning.
- b. Trim excess bridgewire using Exacto knife.
- c. Using a No. 1683 Morse taper pin reamer (Size No. 5) that has been ground to 0.0646 in., ream the 0.064 (+0.000, -0.005)-in. internal diameter hole of the glass-to-metal seal header.
- d. Assemble the stainless steel sleeve P-1002 to the glass-to-metal seal header as shown in Drawing P-1003.
- e. Using Amco 121 acid flux and solder type AG-5-5, solder the stainless steel sleeve to the glass-to-metal seal header as shown in Drawing P-1003. Remove any solder material on the outer metal case area of the header.
- f. Clean the glass header sleeve assembly P-1003 in isopropyl alcohol for 15 minutes and then air dry. Clean in Naconal for 15 minutes and air dry. Put in ultrasonic cleaner with isopropyl alcohol for 5 minutes and then air dry. Put in oven set at 60-74°C for 15 minutes.
- g. Inspect with the aid of "black light" to ensure all the acid flux has been removed from this assembly.

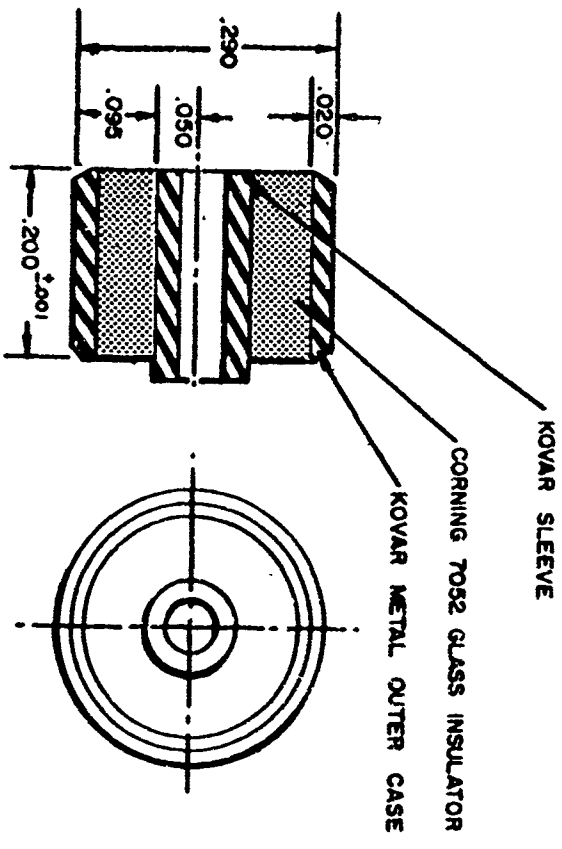
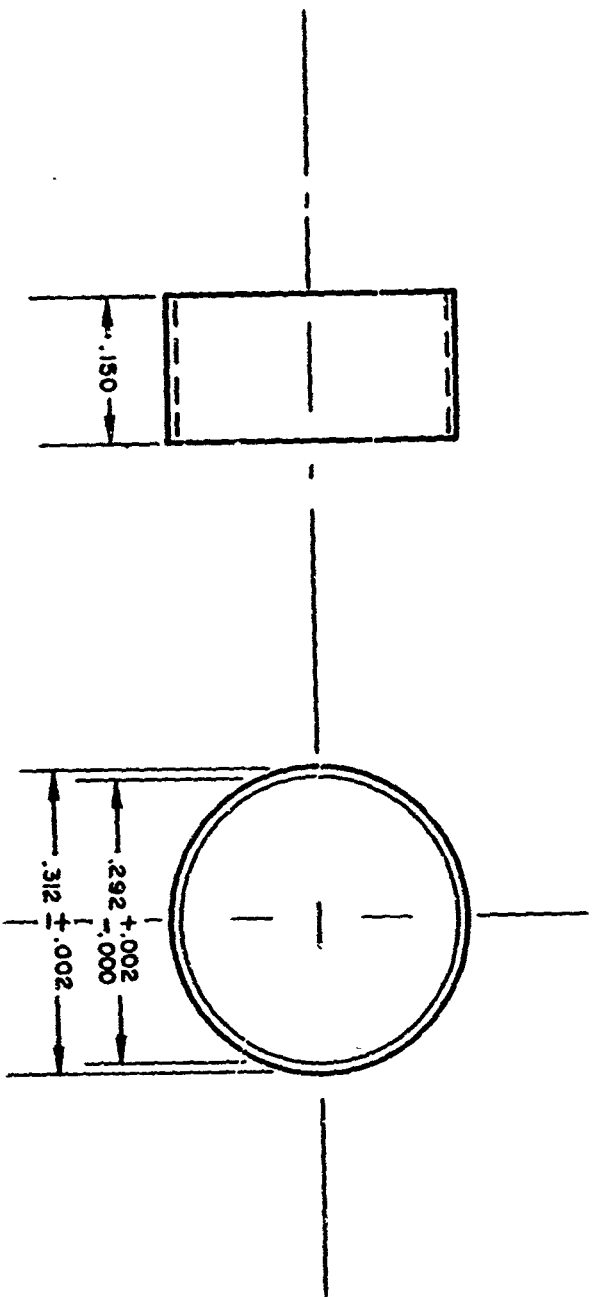

Figure B-1. Drawing 3594, Glass-to-Metal Seal Header.



- Notes:
1. Tin Plate in Accordance with MIL-T-10727 Type (0.002 to 0.000 4 in. Thick).
 2. Remove All Burrs and Sharp Edges

Figure B-2. Drawing P-1002, Sleeve (Stainless Steel Tubing, Type 321).

Notes:

1. Silver Solder Type AG 5. 5
Warp S-571
2. Avoid Solder on this Surface
3. Tin Plate Sleeve Per
Spec MIL-T-10727 Type 1
(0.0002 to 0.0004 in. Thick)

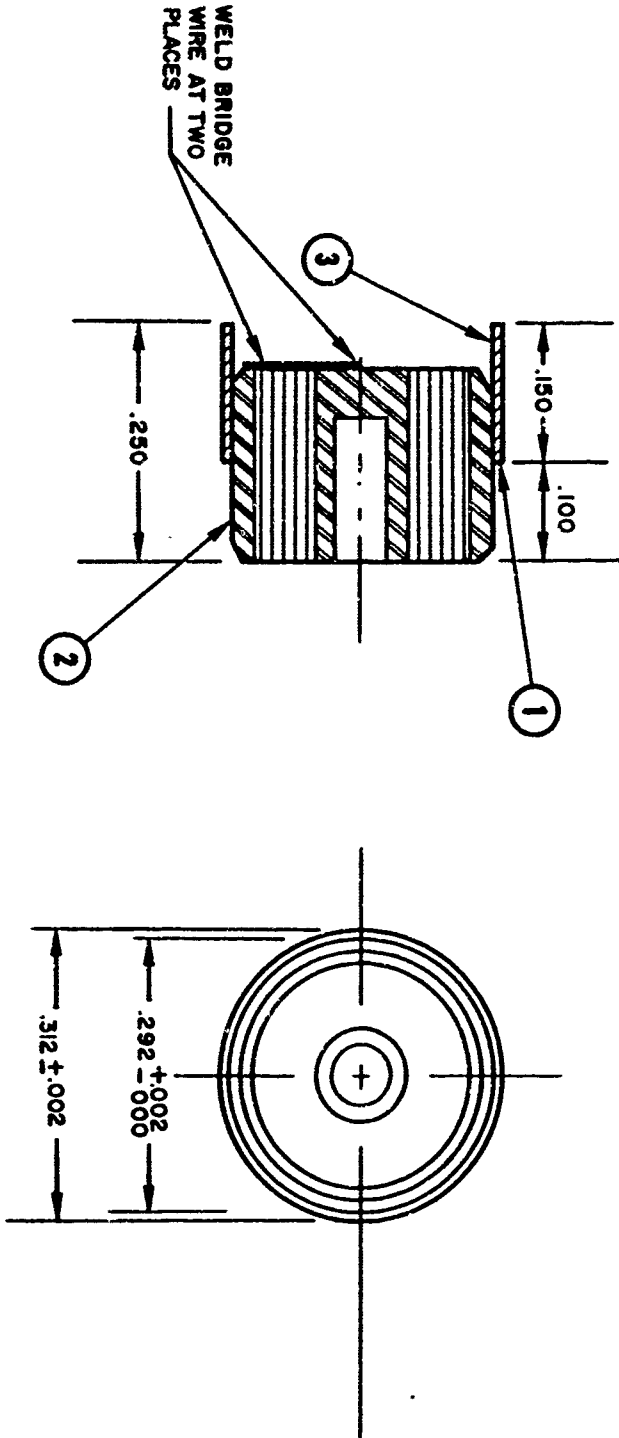

Figure B-3. Drawing P-1003, Glass Header Sleeve Assembly 3594.

2.1.4 Assembly Procedure for Glass Header Sleeve Assembly 3595

- a. Using a No. 1683 Morse taper pin reamer (Size No. 5) that has been ground to 0.0646 in., ream the 0.064 (+0.000, -0.005)-in. internal diameter hole of the glass-to-metal seal header.
- b. Clean the header with isopropyl alcohol and air dry.
- c. Assemble the electrical socket connector P-1005 into the 0.091-in. internal diameter of the glass-to-metal seal header as shown in Drawing P-1004. Using Amco 121 acid flux and solder type AG-5-5, warp S-571, solder the connector into the internal diameter of the header. Using Veeco leak detection, check soldered joints for leaks.
- d. Assemble the stainless steel sleeve P-1002 to the glass-to-metal seal header as shown in Drawing P-1004.
- e. Using Amco 121 acid flux and silver solder type AG-5-5, solder the stainless steel sleeve P-1002 to the glass-to-metal header as shown in Drawing P-1004. Remove any solder on the outer metal case of the header.
- f. Clean the glass header sleeve assembly P-1004 in isopropyl alcohol for 15 minutes and then air dry. Clean in Nacconal for 15 minutes and air dry. Put in ultrasonic cleaner with isopropyl alcohol for 5 minutes then air dry. Put in oven set at 60-74°C for 15 minutes.
- g. Inspect with the aid of "black light" to ensure all acid flux has been removed from this assembly.

2.1.5 Fabrication and Processing of the Voltage Switch Electrode

- a. Fabricate aluminum electrode according to Drawing P-1006.
- b. The electrolytic coating of the aluminum electrode is accomplished by the cold process method of the Sanford Process Co., Inc., of Los Angeles, Calif.

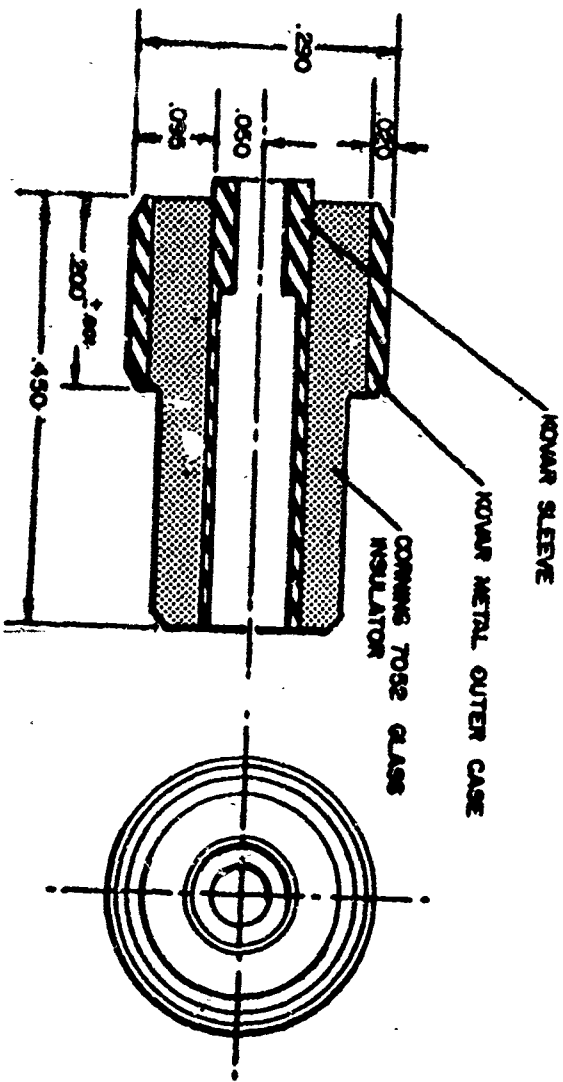

1335-0- -1

Figure B-4. Drawing 3595, Glass-to-Metal Seal Header.

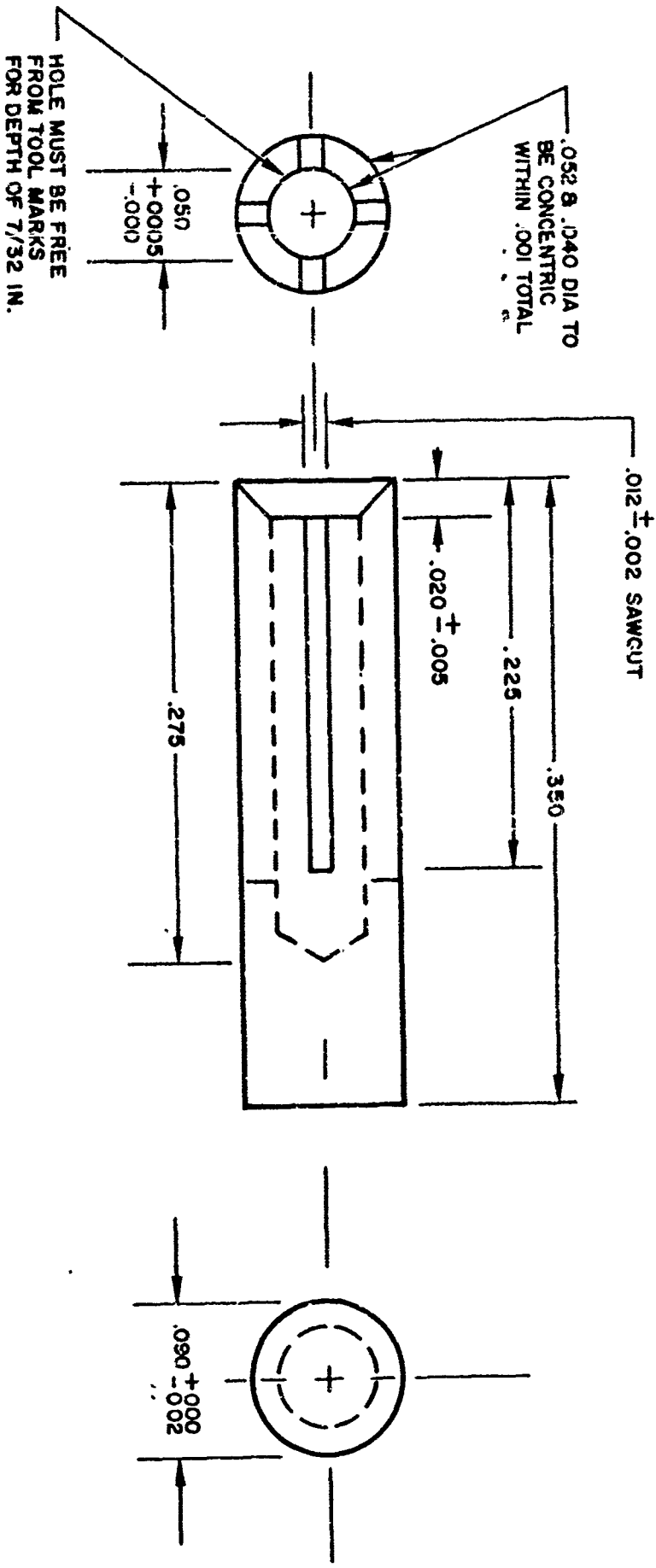

- Notes:
1. Saw Cuts must be Central Within 0.003 in.
 2. Saw Cuts and Holes Must be Free of Burrs and Chips
 3. Dimensions Shown are After Plating
 4. Tin Plate 0.0002 in. Thick; Type 1 MIL-T-10727

Figure B-5. Drawing P-1005, Electrical Connector (Phosphate Bronze Rod, Comp. A Spring Temper 7 No. 40, Spec. QQ-B-7469).

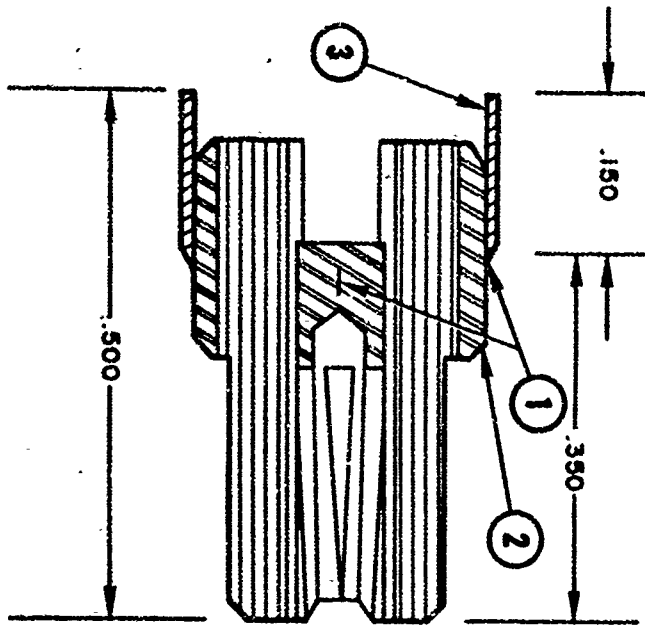

- Notes:
1. Silver Solder Type AG 5.5
Warp S-571
 2. Avoid Solder on this Surface
 3. Tin Plate per Spec
MIL-T-10727 Type I
(0.0002 to 0.0004 in. Thick)

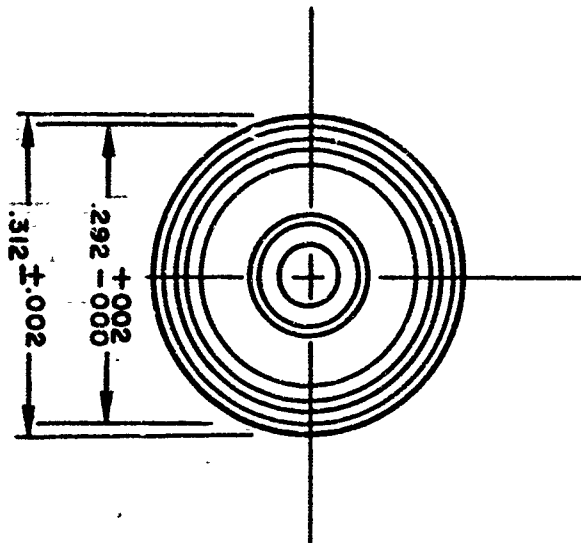

Figure B-6. Drawing P-1004, Glass Header Sleeve Assembly 3595.

- Note:
1. Electrolytically Coat
2 Mills Aluminum-Oxide
Over Entire Surface.
 2. Electrode Bare Metal
Contact Permissible
± 0.020 From Centerline
of Electrode

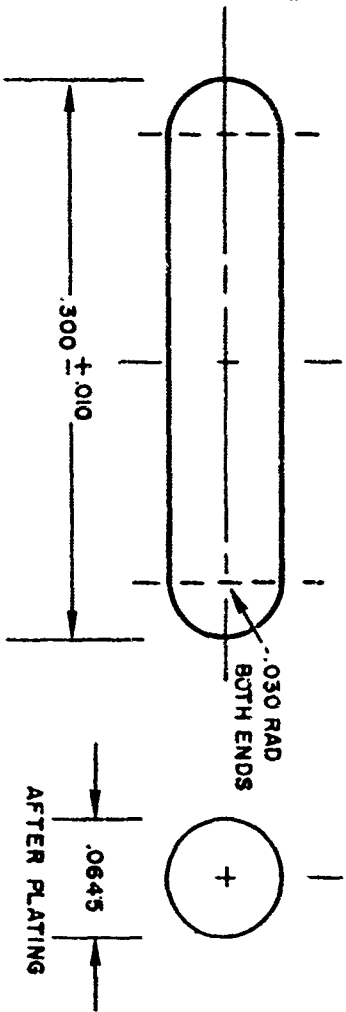

Figure B-7. Drawing P-1006, Aluminum-Oxide Coated Aluminum Electrode
(0.0625-in.-dia, 99% 250 Temper Aluminum).

- c. In a clean pyrex beaker, boil the aluminum-oxide coated aluminum electrode in distilled water (which has been previously filtered) for 30 minutes. Decant the distilled water and transfer the electrodes to a dry weighing bottle (Cat. No. 10-6280, Los Angeles Chemical Co.). Dry in oven at 120°F for 30 minutes.

2. 1. 6 Procedure for Assembling Voltage Switch Electrode Header Assembly

- a. In individual weighing bottles (Cat. No. 10-6280, Los Angeles Chemical Co.), dry the glass header sleeve assemblies P-1003 and P-1004 and aluminum-oxide coated aluminum electrodes in oven for 30 minutes at 120° to 150°F.
- b. Remove glass header assembly P-1004 and electrode P-1006 from oven and assemble electrode into the 0.0646-in. internal diameter of the glass-header assembly P-1004 with the aid of long nose round pliers (4-in. size, No. 36-300 1/2 Lindstrom). Assemble the electrode in the header's internal diameter to approximately 0.100 in. in depth.
- c. Remove the glass header sleeve assembly P-1003 from oven and assemble the electrode (opposite end of that assembled in the previous operation) in the 0.0646-in. internal diameter of the glass header sleeve P-1003. Maintain the 0.600-in. dimension of the assembly as shown in Drawing P-1003.
- d. With the long nose round pliers, expand the internal diameter of the RNF Thermofix plastic (Size 8 x 0.280-in. length) to permit its slipping over the outer diameter of the header sleeve assembly P-1003. Position the Thermofix plastic material on the voltage switch electrode header assembly as shown in Drawing P-1007. Place the assembly in oven at 260° to 270° F for 5 minutes to allow for the shrinkage of the plastic material to its recovered dimension.

Notes:

- 1. Silver Solder Type AG 5.5
Warp QQ-S-571

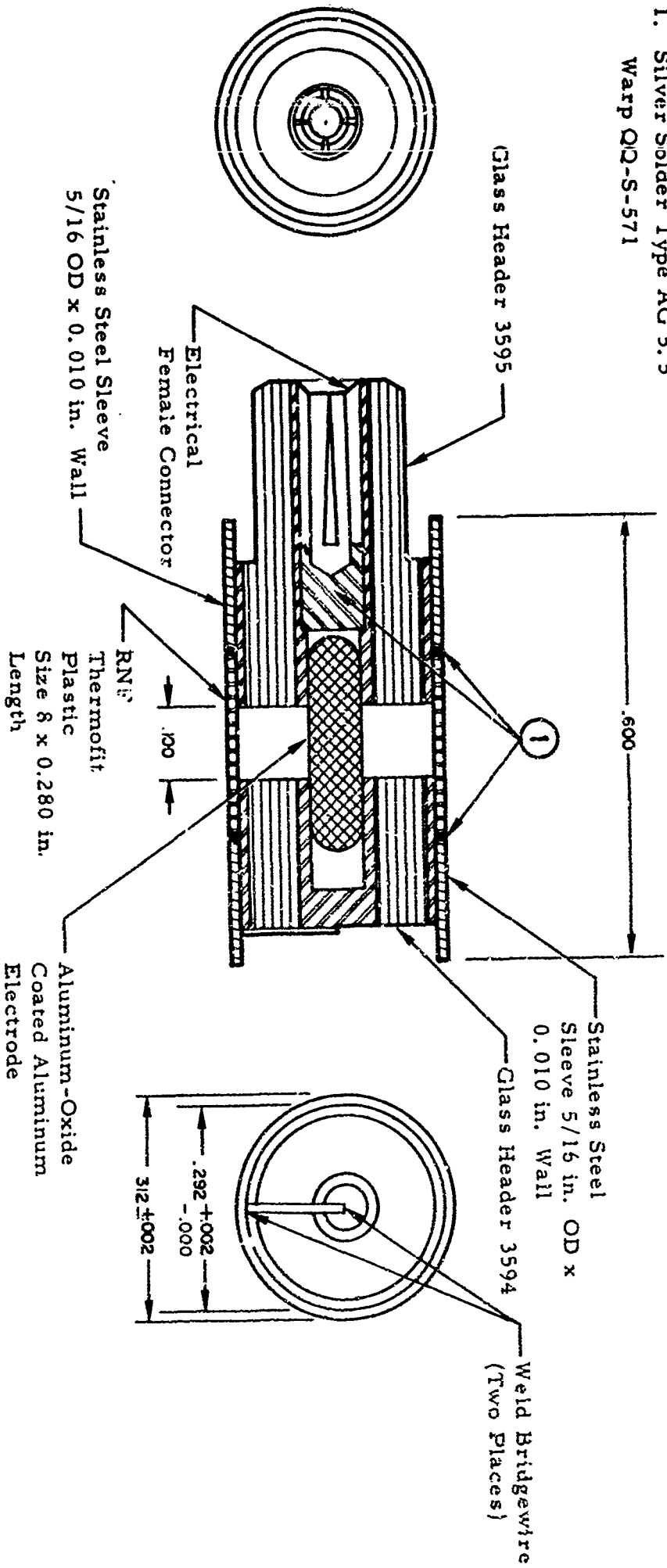

Figure B-8. Drawing P-1007, Voltage Switch Electrode Header Assembly.

2.1.7 Procedure for Assembling Exploding Bridgewire
Initiator Voltage Switch Assembly P-1001

- a. Clean coaxial connector P-1009 and outer case P-1008 in ultrasonic cleaner with isopropyl alcohol for 5 minutes. Air dry.
- b. Assemble the voltage switch electrode header assembly P-1007 into the 0.327 (+0.002, -0.000)-in. internal diameter of the outer case P-1008. Position the P-1008 outer case in relation to the P-1007 assembly so that the stainless steel sleeve extends approximately 0.020 in. beyond the end of the outer case.
- c. Using Amco 121 acid flux and soft solder type SN 60 WS QQ-S-571, solder both ends of the voltage switch electrode header assembly P-1007 to the outer case P-1008.
- d. Inspect the solder joints for hermetic seal using Veeco leak detector.
- e. Clean the above assembly in isopropyl alcohol and air dry. Clean in Nacconal for 15 minutes and air dry. Put in ultrasonic cleaner with isopropyl alcohol for 5 minutes; then air dry.
- f. Assemble coaxial connector P-1009 to the 0.327 (+0.002, -0.000)-in. outer diameter of the outer case and, using Amco acid flux and soft solder type SN 60 WS, solder the coaxial connector to the outer case.
- g. Clean the initiator voltage assembly P-1001 in isopropyl alcohol and air dry. Clean in Nacconal for 15 minutes and air dry. Put assembly in ultrasonic cleaner with isopropyl alcohol for 5 minutes.

1. Silver Solder Type AG 5. 5
Warp QQ-S-571.
2. Tin Plate in Accordance
With MIL-T-10727 Type 1
(0.0002 to 0.0004 in. Thick)

Notes:

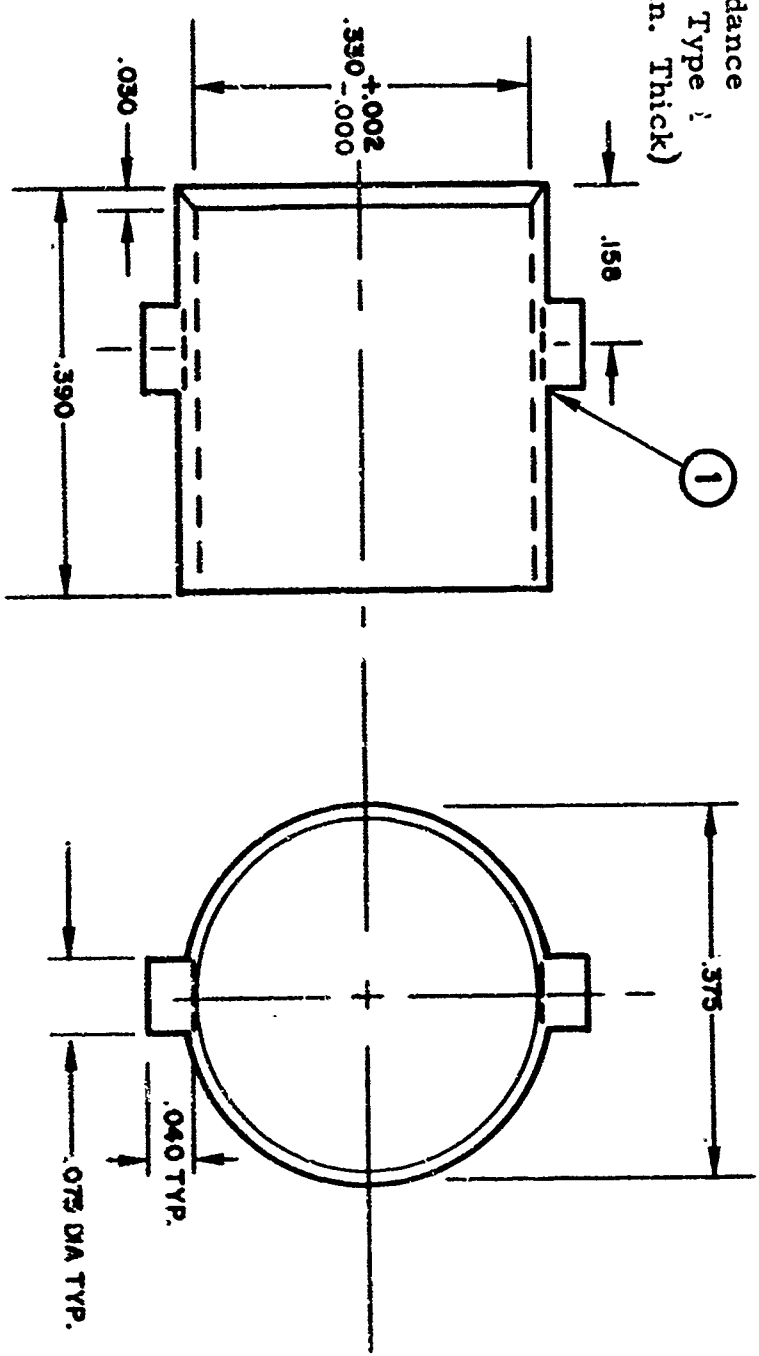

Figure B-9. Drawing P-1009, Coaxial Connector (Stainless Steel Tubing, Grade 321).

- Notes:
1. Remove All Burrs and Sharp Edges
 2. Tin Plate per MIL-T-10727 Type I (0.0002 to 0.0004 in. Thick)

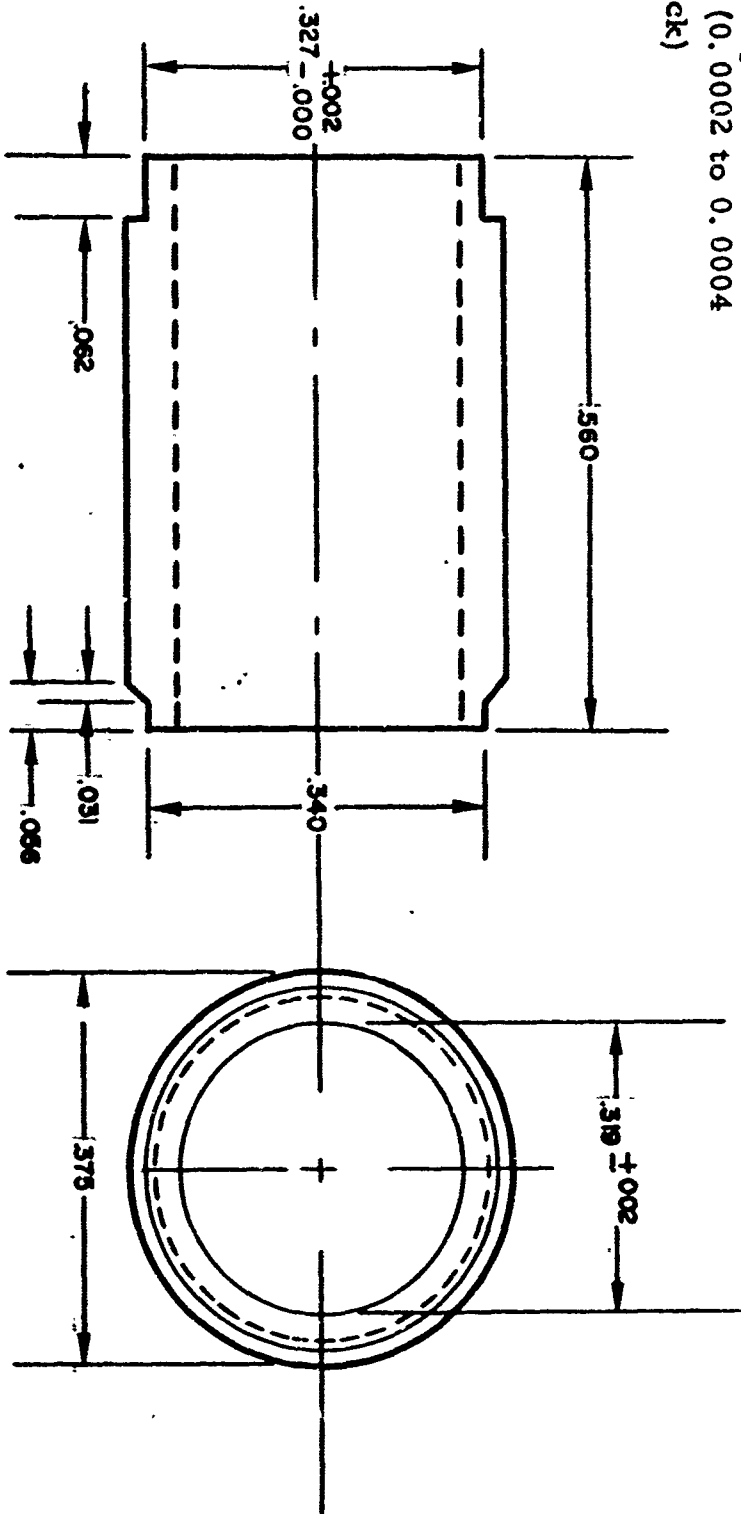
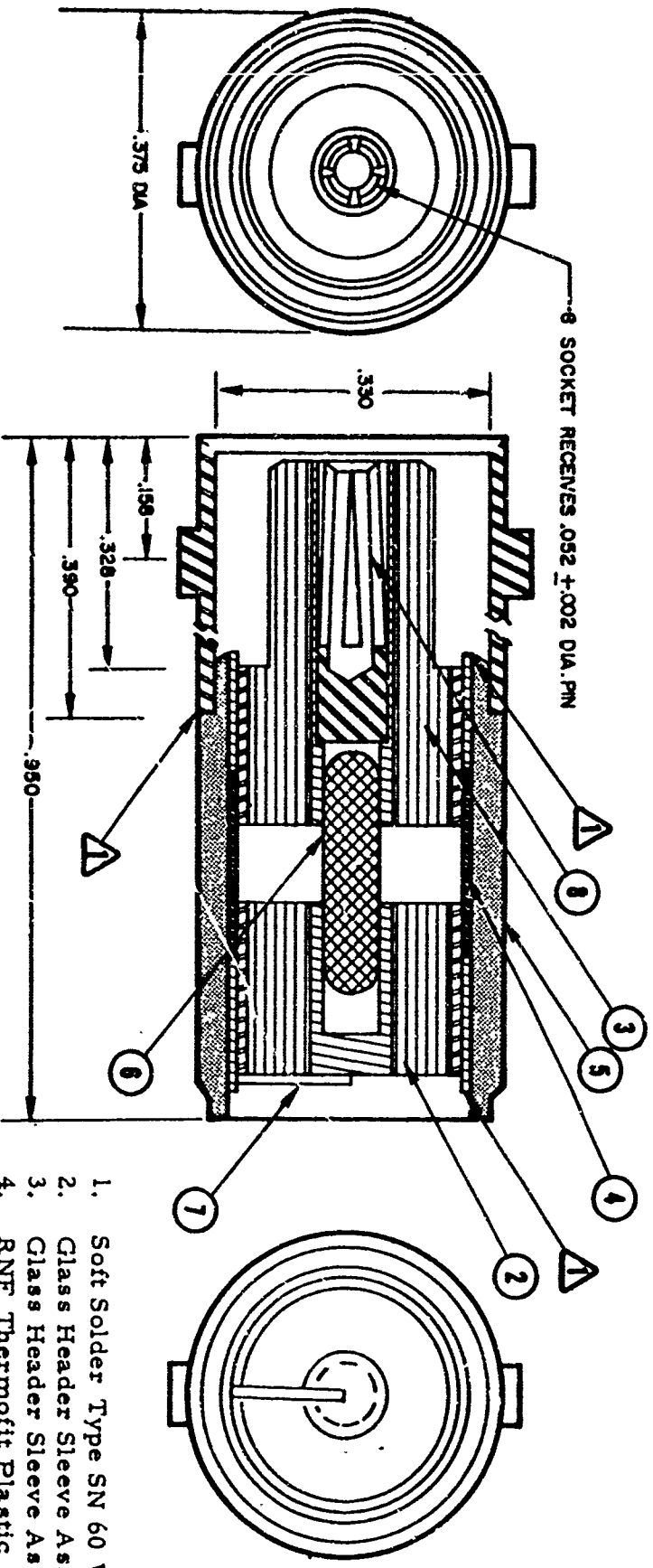

Figure B-10. Drawing P-1008, Outer Case (Stainless Steel Tubing, Grade 321).



1. Soft Solder Type SN 60 WS QQ-S-571
2. Glass Header Sleeve Assembly 3594
3. Glass Header Sleeve Assembly 3595
4. RNF Thermofit Plastic
5. Outer Case Assembly
6. Aluminum-Oxide Coated Aluminum Electrode
7. Bridgewire
8. Electrical Connector (Female Socket, Mates with Cable Plug Electrical Connector DAGE-95712-2085-1)

Figure B-11. Drawing P-1001, EBW Initiator Voltage Switch Assembly.