

UNCLASSIFIED

AD NUMBER

AD525180

CLASSIFICATION CHANGES

TO: UNCLASSIFIED

FROM: CONFIDENTIAL

LIMITATION CHANGES

TO:
Approved for public release; distribution is unlimited.

FROM:
Distribution authorized to U.S. Gov't. agencies and their contractors;
Administrative/Operational Use; 13 FEB 1973.
Other requests shall be referred to Army Assistant Chief of Staff for Force Development, Washington, DC 20310.

AUTHORITY

31 dec 1979 per document marking; AGO, D/A LTR
11 JUN 1980

THIS PAGE IS UNCLASSIFIED

THIS REPORT HAS BEEN DELIMITED
AND CLEARED FOR PUBLIC RELEASE
UNDER DOD DIRECTIVE 5200.20 AND
NO RESTRICTIONS ARE IMPOSED UPON
ITS USE AND DISCLOSURE.

DISTRIBUTION STATEMENT A

APPROVED FOR PUBLIC RELEASE;
DISTRIBUTION UNLIMITED.

SECURITY

MARKING

The classified or limited status of this report applies to each page, unless otherwise marked.

Separate page printouts MUST be marked accordingly.

THIS DOCUMENT CONTAINS INFORMATION AFFECTING THE NATIONAL DEFENSE OF THE UNITED STATES WITHIN THE MEANING OF THE ESPIONAGE LAWS, TITLE 18, U.S.C., SECTIONS 793 AND 794. THE TRANSMISSION OR THE REVELATION OF ITS CONTENTS IN ANY MANNER TO AN UNAUTHORIZED PERSON IS PROHIBITED BY LAW.

NOTICE: When government or other drawings, specifications or other data are used for any purpose other than in connection with a definitely related government procurement operation, the U. S. Government thereby incurs no responsibility, nor any obligation whatsoever; and the fact that the Government may have formulated, furnished, or in any way supplied the said drawings, specifications, or other data is not to be regarded by implication or otherwise as in any manner licensing the holder or any other person or corporation, or conveying any rights or permission to manufacture, use or sell any patented invention that may in any way be related thereto.

DISCLAIMER NOTICE

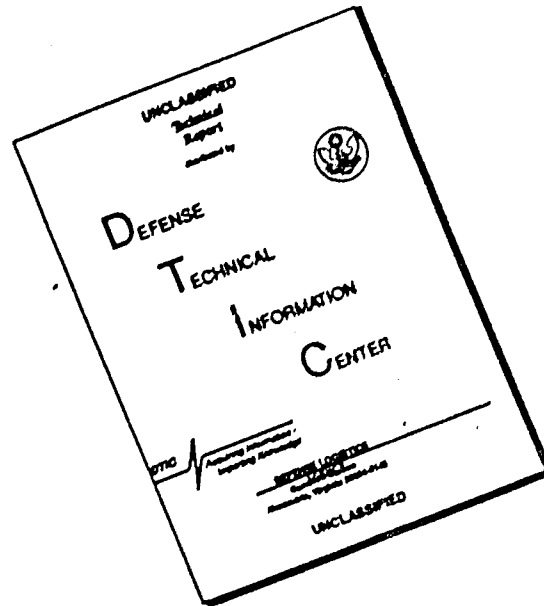

THIS DOCUMENT IS BEST QUALITY AVAILABLE. THE COPY FURNISHED TO DTIC CONTAINED A SIGNIFICANT NUMBER OF PAGES WHICH DO NOT REPRODUCE LEGIBLY.



CONFIDENTIAL

**DEPARTMENT OF THE ARMY
OFFICE OF THE ADJUTANT GENERAL
WASHINGTON, D.C. 20310**

IN REPLY REFER TO

DAAG-PAP-A (M) (21 Mar 73) DAMO-ODU

12 April 1973

SUBJECT: Senior Officer Debriefing Reports: Senior Advisors, ARVN, 1st, 3rd, 5th, 7th, 9th, 25th and 18th Infantry Divisions, Period Ending February 1973 (U)

AD 525180

SEE DISTRIBUTION

1. Reference: AR 525-14, Senior Officer Debriefing Report (U), 2 July 1971.
2. Transmitted herewith are reports of Senior Advisors to ARVN Infantry Divisions, for the period ending February 1973.
 - a. COL George Millener, Jr., SA, 1st ARVN Infantry Division, DAMO-ODU, 73B011, Inclosure 1
 - b. COL C. B. McCoid, SA, 3rd ARVN Infantry Division, DAMO-ODU, 73B014, Inclosure 2
 - c. COL W. F. Ulmer Jr., SA, 5th ARVN Infantry Division, DAMO-ODU, 73B006, Inclosure 3
 - d. COL William Davis, SA, 7th ARVN Infantry Division, DAMO-ODU, 73B009, Inclosure 4
 - e. COL Theodore C. Williams, Jr., SA, 9th ARVN Infantry Division, DAMO-ODU, 73B010, Inclosure 5
 - f. COL Harry A. Yoder, SA, 25th ARVN Infantry Division, DAMO-ODU, 73B013, Inclosure 6
 - g. COL John C. Evans, SA, 18th ARVN Infantry Division, DAMO-ODU, 73B022, Inclosure 7
3. These reports are provided to insure appropriate benefits are realized from the experiences of the authors. The reports should be reviewed in accordance with paragraphs 3 and 5, AR 525-14; however, they should not be interpreted as the official view of the Department of the Army, or of any agency of the Department of the Army.

Regraded unclassified when separated
from classified inclosure.

CONFIDENTIAL

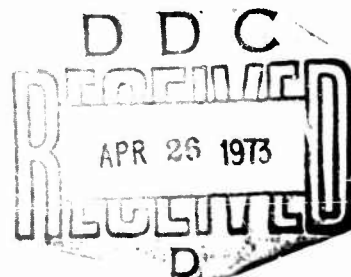

CONFIDENTIAL

4. Information of action initiated under provisions of AR 525-14, as a result of subject reports should be provided to the Deputy Chief of Staff for Military Operations, ATTN: DAMO-ODU within 90 days of receipt of covering letter.

BY ORDER OF THE SECRETARY OF THE ARMY:



VERNE L. B. LRS
Major General, USA
The Adjutant General

7 Incls
as

DISTRIBUTION

Commander

US Continental Army Command
US Army Combat Developments Command
US Army Materiel Command

Commandant

US Army War College
US Army Command and General Staff College
US Army Adjutant General School
US Army Air Defense School
US Army Armor School
US Army Aviation School
US Army Civil Affairs School
US Army Combat Surveillance &
Electronic Warfare School
US Army Engineer School
US Army Field Artillery School
US Army Infantry School
US Army Institute for Military Assistance
US Army Intelligence School
US Army Medical Field Service School
US Army Military Police School
US Army Ordnance School
US Army Quartermaster School
US Army Signal School
US Army Transportation School

Copies furnished:

Office, Chief of Staff, US Army (DWSA)
Deputy Chiefs of Staff
Chief of Research and Development
Assistant Chiefs of Staff
Chief of Engineers
Commanders in Chief
US Army, Europe
US Readiness Command
Commander, US Army Forces Southern Command

CONFIDENTIAL

DAAG-PAP-A (M) (21 Mar 73) DAMO-ODU
DISTRIBUTION (Continued)

12 April 1973

Commandant of the Marine Corps
Commandant

Armed Forces Staff College

The National War College

Defense Intelligence School

Senior Army Representative, Education

Center, Marine Corps Development & Education
Command

The Air University Library

Defense Documentation Center

Commander, US Army Logistics Doctrine Systems &
Readiness Agency

CONFIDENTIAL

HEADQUARTERS
UNITED STATES MILITARY COMMAND, VIETNAM
APO SAN FRANCISCO 96222



MACDO-341

13 FEB 1973

SUBJECT: Senior Officer Debriefing Report (RCS: CSFOR-74)

Assistant Chief of Staff for Force Development
ATTN: FOR OT UT
Department of the Army
Washington, DC 20310

1. Ref: AR 525-14 (C).

2. In accordance with reference as above, the Completion of Tour Report of Colonel George A. Millener, Jr., Senior Advisor, 1st Infantry Division (ARVN), is inclosed. A copy of the subject report has been forwarded to CINCUSARPAC, for information.

C M Talbott

C. M. TALBOTT
Major General, USAF
Director of Operations

UNCLASSIFIED INFORMATION
EXCEPT WHERE SHOWN OTHERWISE
Subject to Criminal

Not Releasable to Foreign Nationals

DAMO-ODU
73B011
Inclosure 1

CLASSIFIED BY SA. 1ST DAT
SUBJECT TO GENERAL DECLASSIFICATION
SCHEDULE OF EXECUTIVE ORDER 11652
AUTOMATICALLY DOWNGRADED AT TWO YEAR
INTERVALS
DECLASSIFIED ON 31 DECEMBER 1979

CONFIDENTIAL

CONFIDENTIAL

Not Releasable to Foreign Nationals

DEBRIEFING REPORT

Debrief Report by: Colonel George A. Millener, Jr.

Duty Assignment: Senior Advisor, 1st Infantry Division (ARVN)

Inclusive Dates: 20 May 1972 to 29 January 1973.

1. **INTRODUCTION:** The period of this report includes Division operations during the defensive battle to contain the North Vietnamese Army (NVA) Spring Offensive of 1972, the GVN counter-attack and stabilization of the tactical situation and the deployment of the Division at the effective time of the cease-fire. From the period 20 May to approximately 1 October 1972, the Division was entirely committed to the defense of Thua Thien Province and Hue City. All efforts and resources were devoted to the destruction of enemy forces, the restoration of GVN controlled territory, control of the tactical area of responsibility (TAOR) and protection of the populated lowland areas of Thua Thien Province, to include QL 1. During the same period, the Advisory effort was intensified due to the unprecedented use of US combat support assets; however, the Advisory establishment continued to phase down to austere manning levels. As a result, Vietnamization was accelerated to permit ARVN control of US combat support assets under Advisor monitorship, and in some cases supervision. During the period of this report US Advisory efforts were reduced commensurately with the reduction in Team strength. Ultimately the Advisory Team was only capable of maintaining an appreciation of the tactical situation and providing required reports to higher headquarters.

2. **ORGANIZATION:** The 1st Infantry Division is organized as shown in Inclosure 1. The division consists of four regiments rather than the normal three with the 51st Regiment being assigned on 1 September 1972. The regiments of the division continue to employ four battalions per regiment with the fourth battalion (strike force battalion) consisting of a reduced strength headquarters. The four battalion configuration is used principally to alleviate the command and control problem generated by the large TAOR.

3. **PERSONNEL:** a. General. There is virtually no advisor effort in the G1 area. During the report period, the G1 position has been filled by two highly qualified officers, LTC Chuong and LTC Tho. Both are excellent staff officers and professional administrators. Additional heavy emphasis on personnel management has been applied by the most recent commanding general, BG Than. Personnel losses incurred by the division since March 1972 severely depleted the ranks of junior officers and NCO leaders. Since October 1972 the CG has personally stressed and supported a comprehensive program to retrain and refit the maneuver battalions through a program of rotation from active combat areas to regimental rear areas where a combined division and regimental team conducted the program. Strength as of 19 January 1973 is shown in Inclosure 2. 2

6

CONFIDENTIAL

CONFIDENTIAL

Debrief Report, 1st Inf Div

b. Quality.

(1) Training. From the period April - August 1972, the division was totally committed to combat operations and sustained significant casualties among unit leaders. The reality of the tactical situation dictated that training would be accomplished in the fox hole. The division secured the initiative on approximately 1 September 1972 which permitted a greater opportunity to emphasize unit training programs and specialized training. Responsible leaders of the division are highly cognizant of the importance of training, particularly the training of unit level cadre, and have maintained steady pressure at every level to achieve the training goals. The unusual professionalism and competence of the general staff of the 1st Division should also be noted. In every staff functional area, particularly the G2, G3, and G4, the primary staff officer contributed immeasurably to the success of the division through a consistently superior performance of duty. The planning and decision making cycle at division level closely approximates doctrinal procedures for equivalent US staffs and its quality far exceeds that found at regimental and lower levels of the division.

(2) Leadership. As in any divisional size unit, the quality of leadership is distributed over a normal curve. The quality of leadership from the division through regimental and battalion levels is uniformly excellent. The quality of leadership at company and lower levels begins to become more erratic; although, it should be considered as generally good. During the period of this report there have been two division commanders and one acting division commander. The acting division commander was the ADC, Col Diem who is evaluated in para 3b(v) below. From May through August the division was commanded by MG Fhu who was relieved for reasons of ill health by BG Than.

(a) Commanding General, BG Than. Gen Than assumed command of the division on approximately 5 October 1972. He is an apparently highly skilled, intelligent and extremely professional soldier. It is difficult to rate Gen Than's ability to direct the tactical operations of the division in the same context as the previous commanders during the reporting period because of the grossly different tactical environment. Gen Than inherited a very stable TACD in which the opposing enemy forces had been thoroughly defeated during LAM SON 45. Notwithstanding the division's dominance in the TACD, operations continued in the same skilled and aggressive manner that have characterized division operations in the past. Taking advantage of an ability to travel to forward field locations, Gen Than began a program of daily visits to units engaged in combat to personally stress the improvement of the individual soldier. He is obviously respected and admired by his subordinates because of his ability, experience, and soldierly mien. Although untried in battle, to the extent of his predecessors, Gen Than displays the qualities of leadership which would seem to indicate his potential for success.

(b) Assistant Division Commander, Col Diem is an outstanding AIC. He accomplishes most of the current tactical planning and supervises the division scheme for the integration of fire support with maneuver. Col Diem is aggressive, has a "no nonsense" view towards military operations and

CONFIDENTIAL

Debrief Report, 1st Inf Div

has the respect of subordinates. For an extensive period of time, Col Diem performed as acting division commander in a highly commendable manner. Assuming command at a time when the tactical situation permitted more vigorous offensive action than since the beginning of the NVA offensive, he launched the division on a series of well planned operations that ultimately rendered the 324B NVA Division ineffective, restored the battle area, and placed the division in an advantageous defensive posture.

(c) Regimental Leaders. See para 9.

(d) Personnel Management. The morale of the division is good. The Commanding General has a keen insight into the psychological basis for esprit and ~~man~~. He constantly urges responsible leaders to establish incentives for performance and has developed a system for the recognition of achievement, reduction in AWOL and desertion rates, and assistance for dependents. The G1 and AG appear to manage the division's personnel assets with professional aplomb. The division strength is normally maintained at a relatively high level without serious shortfall in grade or MOS structure.

4. INTELLIGENCE: a. Government Intelligence Organization.

(1) Mission. The organization handling intelligence for the 1st Division is the G2, his staff and military intelligence detachment (MID). The mission of the G2 is to provide accurate and timely estimates on enemy intentions, capabilities, and the overall enemy situation within the Division's AC and adjacent AOs. The intelligence estimates are provided for the commanding general.

(2) Functions. The G2 derives information on the enemy from a variety of sources. Its organic ASTD, sensors, VR, PWs, documents, agents, radar, and an analysis of a combination of sources. The information is gathered by the subordinate section of the G2 and MID and analyzed and disseminated to the CC and Div Staff for input on operations.

(3) Organization. The G2 section is organized with four sections: Admin, order of battle, terrain, and weather, and a G2 air section.

(4) Capabilities. The G2 and his staff are very effective and produce considerable accurate and timely information for the CG and his staff. The current G2 was the MID commander for several years and worked under the former G2 who did an exceptional job in reorganizing and re-vitalizing the G2 section into the strongest staff section in the 1st Division TAGR. The ASTD has continually been the primary source of the G2's most accurate and timely information on the enemy. The G2 and his staff are most effective in exploiting enemy documents and VC/NVA PWs and Hoi Chanhs. Without exception when documents and PW/Hoi Chanhs appear at the Division HQs the G2 and his staff work until the job has been completed and produce a

CONFIDENTIAL

CONFIDENTIAL

Debrief Report, 1st Inf Div

report to the CG and for subordinate commands within the Div. This hard work and timeliness has paid off with considerable success in Div operations.

b. Evaluation of Intell efforts.

(1) Significant limiting factors. The lack of sufficient mobility to implant sensors, perform visual aerial reconnaissance of the AO, conduct Air Cav missions and long range reconnaissance patrolling into enemy held territory are probably the most significant limiting factors. The lack of technical training and ability also limits the G2 in collecting and properly understanding some forms of intelligence gathered. Although they have a technical intelligence section in the MID, the 1st Division G2 receives little information from this source. The G2 also fails to properly exploit captured enemy equipment. The departure of US assets is causing a serious problem to the G2. The receipt of photo coverage of the 1st Division AO is no longer timely and soon is expected to be close to non-existent. The targeting capabilities of the combined G2/G3/Arty sections have failed to produce a sufficient number of accurate hard targets for TAC air, although they have had some success for B-52 and massed arty strikes.

(2) Coordination between agencies. The G2 coordinates regularly with all intell agencies within the 1st Division, province, district, and the city of Hue. The coordination is effective, although, most of the information is provided by the G2. At times, each agency holds onto information refusing to give it to other agencies until it is too late for further reaction. This causes some inefficiency and inaccurate accounts between agencies.

(3) Penetration of Insurgent Forces in Infrastructure. This mission is no longer conducted by the 1st Division.

(4) Effectiveness of Communications. Communication security is one of the weakest areas within the 1st Division G2. A recent enemy PW stated the NVA intercept and understand ARVN intentions, operations, and dispositions from ARVN radio communications. Nearly all attempts to improve radio security have failed.

(5) Adequacy to Supply Counterintelligence Requirements. Counterintelligence is conducted by the Military Security Services (MSS) and is not under the G2, therefore the ARVN G2 has little to do with counterintelligence.

c. Counterintelligence.

(1) Mission. The Military Security Services (MSS) conduct all counter intelligence activities for the 1st Division. Their primary mission is to regulate movement of personnel in/on various basecamp locations. This is done through security checks conducted on civilian and military personnel in cooperation with the National Police.

(2) Function. The MSS conducts investigations on Vietnamese civilians and military personnel and reports to the CG. Interrogations are also

CONFIDENTIAL

CONFIDENTIAL

Debrief Report, 1st Inf Div.

conducted on VC/NVA PWs and Hoi Chanhs and this information is passed on to the G2. The MSS cooperates with many other agencies, comparing information and passing on their evaluations to the G2 and the CG.

(3) Organization. The MSS is subordinate to the G5 and has teams down to regimental level. The MSS Chief is a LTC slot, however, it is headed by a Cpt in the 1st Division.

(4) Capability. The MSS is only effective in its primary function of granting security clearances to Vietnamese civilians who enter ARVN installations. However, in this capacity they are basically inefficient and corrupt. They have little capability in denying enemy information from ARVN installations and seldom are accurate on pending enemy attacks. Aside from security clearances, they produce a lot of paperwork.

5. OPERATIONS: a. Goals (Mission). The mission of the division is to defend Thua Thien Province, Hue City, to include the port facilities, and to secure QL 1 within the TAOR. Concurrently, the division is engaged in a vigorous program of maximum assistance to the Sector forces in the form of POL/War programs aimed at maintaining the confidence of the population in the government's ability to protect them.

b. General Concept. During the period May-September 1972, the Division deployed its forces along the primary routes of approach to Hue from the A Shau Valley conducting a defense in the jungled mountains as deep to the southwest as possible. These routes were generally the Bo River and Road 77, Rt 547 and Gorman's Road with the primary approach being Rt 547. During the period September 1972-January 1973 the division assumed a monsoon posture by occupying fire bases along key terrain from which company-sized elements conducted offensive clearing operations to deny NVA/VC access to the populated lowlands and to uncover and destroy caches of war material. Operations during the monsoon season were largely dictated by the effects of heavy rains, limited visibility restricting all forms of air operations, and trafficability of the terrain. During the period November 1972-January 1973, the emphasis of division operations was placed on continuous offensive search operations along enemy infiltration routes to the populated areas prior to the cease fire. These operations served to spoil enemy plans to establish operating bases in the Piedmont areas adjacent to the lowlands, maintained the momentum of the initiative for division forces, and seriously depleted the enemy's capability to mount significant operations.

c. Summary of Operations of Note. During the reporting period, the division engaged in three major operations consisting of LAM SON 45/72, LAM SON 63/72, and LAMSON 1/73. LAM SON 45/72 was launched on 5 March 1972 in reaction to an apparent buildup of enemy forces and materiel in the Dong Cu Hong (YD 5802) - PSB Veghel (YD 549035) area. The attack was launched earlier than normal for the start of dry season operations. Although LAM SON 45/72 was initiated as an independent operation it became apparent after the NVA offensive of 28 March that 1st Division operations had pre-empted a coordinated offensive against Hue from enemy forces, operating on two major axes.

CONFIDENTIAL

CONFIDENTIAL

Not Releasable to Foreign Nationals

Debrief Report, 1st Inf Div

In the initial phase of the operation, i.e., prior to 28 March 1972, elements of two division regiments engaged the 6th NVA Regt at Dong Cu Mong. Assisted by massive fire support to include B-52 strikes, heavy casualties were inflicted on the enemy and friendly objectives were attained on 18 March 1972. The enemy was forced to prematurely commit major reinforcements from the 324B NVA Division consisting of the 29th and 803rd Regiments. Launching heavy attacks to include massive attacks by fire, enemy pressure forced friendly forces to withdraw from the battle area. To cope with the superiority in numbers of enemy forces, the 7th Cav Regt and the 54th Regt were committed to blocking positions along Rt 547 in the vicinity of FSB Bastogne (YD 625 096). Coinciding with the enemy offensive across the DMZ unprecedented enemy action was initiated against FSB Bastogne. Taking advantage of monsoon weather for movement, the density of enemy AA weapons, 57mm and 75mm RR weapons was greatly increased around FSB Bastogne which adversely affected the division's capability to resupply and medevac. By 1 April, division forces exploiting the delaying action forward of FSB Bastogne established a sound defensive line extending from FSB King (YD 623 143) to FSB Bastogne/OP Checkmate to FSB Birmingham (YD 704 102). The month of April saw the fiercest fighting of the war and became a battle of attrition by firepower with heavy use of indirect fire, tactical air and B-52 strikes. Due to the inability of the division to conduct aerial resupply or medical evacuation owing to the heavy concentration of AA weapons, FSB Bastogne was abandoned on 28 April. Friendly forces occupying the line King to Birmingham blocked further enemy advance and virtually destroyed the 29th Regt while it was withdrawing from the battlefield. On 15 May and 25 May FSB Bastogne and OP Checkmate were recaptured and the threat of further enemy advance against Hue from the southwest was greatly reduced. Throughout May and June friendly forces continued to defend, but with an offensive spirit. The area of friendly control was expanded with successful airmobile operations southwest of FSB King and southeast of Bastogne/Checkmate in the Son Na area (YD 6406). With the introduction of long range enemy artillery in the 1st Division TACR which was capable of attacks against Hue and key logistical and command and control facilities, it was required to establish greater depth to the battlefield. 1st Division forces launched a new attack to destroy remaining forces of the 324B NVA Division on 22 July 1972. This attack coincided with a renewed attack by the 324B Division. The Bastogne-Son Na area erupted in the bloodiest battle of the campaign with the greatest use of firepower by both sides yet seen in the war. Enemy forces in control of the high ground surrounding Bastogne to include OP Checkmate, whose loss presaged the new attacks, were able to frustrate friendly attempts to maneuver. On 26 July FSB Bastogne was again abandoned; however, friendly forces maintained a stable defensive line across Rt 547 only 2 kilometers northwest of Bastogne. Until 4 August, when Bastogne and Checkmate were re-occupied, US tactical air and B-52 strikes combined with massed artillery to relentlessly attack enemy positions and destroy them. In retrospect, it is now clear that the period 25 July to 4 August provided the climax of the 1st Division defense of Hue and was the most critical time since April. Massive use of B-52 strikes closely integrated with the scheme of ground maneuver as an innovative form of close air support was a primary reason for the eventual success of friendly forces in overcoming a tenacious enemy. The division seized

7
CONFIDENTIAL

CONFIDENTIAL

Debrief Report, 1st Inf Div

the initiative on 4 August and conducted highly successful clearing operations to the southwest ultimately restoring the TAOR as it existed on 5 March 1972, the beginning of LAM SON 45/72. LAM SON 63/72 marked the assumption of a monsoon posture. Division forces were deployed along a line of key fire bases and, more importantly, the lessons of the campaign were well learned with the occupation of key terrain features well forward of the monsoon line. With the key terrain dominating the routes of approach occupied by friendly forces a more judicious use of troops was accomplished permitting economy of force operations throughout the TAOR reaching from the Song Bo River in the northwest to the Hai Van Pass in the south east. During this period continuous search and clear operations were conducted resulting in the finding of large quantities of war materiel and the continued frustration of enemy attempts to establish a significant threat to Hue and the populated coastal low lands adjacent to QL 1. Commencing with LAM SON 1/73 the 1st Division focused its efforts on the protection of the population during the pre-cessate fire period. Using sector forces under its operational control for the mission of local protection of key points, inhabited areas, and the LOC division forces conducted search and destroy operations in the mountainous areas providing a refuge to enemy forces. While keeping the enemy off balance and unable to mass sufficient forces for significant operations, a vigorous program of patrolling and ambush was accomplished in the piedmont area to prevent infiltration for food collection, proselyting or contact with the VCI. Results of operations described above are as follows:

(1) LAM SON 45/72 (5 Mar-19 Sep 72)

Fri KIA	1201	En KIA	14,582
Fri WIA	4991	POW	32
		Ralliers	2
		Ind Wpns	2,640
		Crew	
		Served Wpns	1,123

(2) LAM SON 63/72 (20 Sep - 31 Dec 72)

FRI KIA	142	EM KIA	1,446
FRI WIA	560	POW	5
		Ralliers	1
		Ind Wpns	533
		Crew Served	
		Wpns	135

d. Training. During the conduct of LAM SON 45 a high percentage of casualties were inflicted upon unit leaders and individual soldiers. The criticality of the tactical situation coupled with the requirement for the total commitment of maneuver battalions in a large TAOR precluded normal training cycles. The effects of the loss of battle seasoned leaders further degraded the quality of training. Due to these circumstances the proficiency

CONFIDENTIAL

12

CONFIDENTIAL

Debrief Report, 1st Inf Div

of units and individuals was below the normal standards of the 1st Division for a brief period. During September with the advent of a more favorable and stable tactical environment, regular rotation of battalion sized units from combat operations to base areas for formal training and refitting was accomplished. Overall, the quality and quantity of training in the 1st Division is adequate with one often neglected exception, officer training. The area of formal training for officers particularly junior staff officers, except for on-the-job training, is notably deficient. The rapid expansion of the ARVN officer corps and limited opportunity for advanced and senior officer schooling has also contributed greatly to the problem. The effects of the problem most seriously impact on the functioning of staffs at battalion and higher levels. As the complexity of staff procedures increases the deficiency becomes more acute until at division level it serves as a crippling factor in the command and control system. The 1st Infantry Division Training Center located at Camp Nguyen Hue conducts individual and specialized training for the division and has successfully met the requirements of the division.

6. LOGISTICS: a. Supply. The supply system of the 1st Division is effective. LTC Nhon, G4 of the Division, meets weekly with the logistics personnel of the regiments and 1st Log Bn to insure supply problems are solved adequately and that requests and issues are promptly handled. However, more emphasis has to be placed on the necessity for current follow-up on requisitions and reconciliations of outstanding due outs. This is particularly important at company thru battalion, regiment to division levels. Regimental S4s are being encouraged to work closely with 1st Log Bn Supply Company. Personnel who work in the G4 section and support units appear to be adequately trained to perform their mission after attending the logistics training schools. Through participation in numerous operations, especially LAM SON 45 and LAM SON 63, their skills have been perfected. Supply shortages exist because of usage and losses sustained during LAM SON 45. Lensatic compasses, helmet liners, 81 and 4.2 mm mortar rounds and tubes for 105mm howitzers are considered by the Division as critical items. Advisors have been checking all available channels to determine the availability of 105mm tubes. However, no answer has been received. As a general rule, major end items are quickly received while other items of supply and repair parts may take considerable time.

b. Transportation. The Division has adequate 2½ ton trucks to accomplish its mission. Approximately 2/3 of the trucks deadlined occurs within artillery battalions, the logistics battalion and the transportation company. These units are continually engaged in transporting ammunition and supplies to field locations.

c. Maintenance. Major Ngsi, the maintenance company commander, has superb facilities and operates an excellent maintenance program. His personnel are well trained and experienced. This company repairs artillery pieces, small arms, radios, wheeled vehicles, and tracks. Repair parts accountability and

CONFIDENTIAL

Debrief Report, 1st Inf Div

and storage are excellent. However, the resupply of repair parts is slow causing considerable deadline of vehicles and artillery pieces. Requisitions have been checked by the advisor and found to be current and up-to-date. If the shortage of engines, transmissions, clutches could be solved, this company would be able to give the Division excellent maintenance support. The Transportation company also has experienced people, good equipment and facilities. This company receives many of its repair parts from the maintenance company. If the repair parts would arrive quickly a better maintenance activity could be maintained. The rebuild program continues to improve. The supply company is evacuating rebuild items in a timely manner while the rebuild depot has improved their maintenance and return of the finished item to the user.

7. COMMUNICATIONS. Day to day signal operations are well run with few problem areas. The planning and coordination by the divisional signal staff and execution by the signal battalion provides adequate communications support during operations. The division relies heavily on the use of telephone communications with all of the attendant problems particularly in the area of communications security. Generally communications security is deplorable particularly over command and operations nets where it should be most stringent. " Circe " type codes are distributed, but not used to any great extent. It has been noted that commanders unfailingly complain of shortages in the rate of supply for batteries to power the AN/PRC-25 radio.

8. COMBAT SUPPORT: a. Artillery. The 1st Division artillery is extremely effective and responsive to the fire support needs of the maneuver commanders. The division artillery has achieved two significant accomplishments even rarely found in comparable US organizations. As a result of MACV emphasis on the implementation of current doctrine for fire support coordination and improved accuracy of fires the division vigorously implemented the concept of a single manager system for fire support coordination by establishing fire support coordination centers under the supervision of the senior artillery man at each appropriate level. These FSCC effectively coordinated all fire support to include tactical air and naval gunfire. Great strides were made in the continuing effort to improve accuracy of fires. The dormant meteorological section was revitalized and provides two artillery met messages daily. A survey plan for the TAOR which included four schemes for the establishment of survey control was implemented and is close to completion. A target area survey to provide additional registration points is also underway. A program of daily registrations is emphasized. All of these programs, combined with careful gunnery techniques, have served to improve the accuracy of fires as well as providing the improved responsiveness through first round accuracy and conservation of ammunition through greater effectiveness.

b. Tactical Air. During the period May through August the division made heavy use of tactical close air support as well as B-52 strikes. The use of US provided air support was a key factor in the success of the division during LAM SON 45. Unfortunately the lavishness of use often

10

CONFIDENTIAL

14

CONFIDENTIAL

Debrief Report, 1st Inf Div

resulted in inadequate maneuver by ground forces and an over-reliance on the effects of air fire power. Too often the immediate application of organic indirect and direct fire weapons was needlessly delayed while waiting for tactical air to arrive in the target area. Conversely, the lack of an adequate airspace coordination system often needlessly precluded the simultaneous application of various forms of firepower on targets of high value. US advisors were most gainfully employed in the area of assisting the ARVN to properly use tactical close air support. If any expertise has been passed it is primarily in creating an awareness of fire support/air space coordination.

c. Aviation. US Army aviation support to the 1st ARVN Division has been outstanding. The selfless dedication and spirit of Army aviation and crewman marks a fitting end to the history of US Army Aviation in Vietnam. In an attempt to "Vietnamize" VNAF, division advisors gradually restricted the use of US assets in favor of VNAF utilization. Because of the extreme confidence of ARVN in the capabilities of US aviation versus VNAF it was often a difficult task; however, the non-availability of US aviation assets ultimately forced the conversion of ARVN particularly in the area of aerial resupply and medical evacuation. Unfortunately, the overall performance of VNAF helicopters in support of the 1st Division tends to be generally inadequate for a variety of reasons. At times VNAF helicopter support was superb, but an underlying current of uncooperativeness and a lack of sense of urgency undermines the close partnership that is necessary between the ground commander and his aviation support. This poor relationship caused by the separation of the airman from the command authority of a ground commander may prove to be an insurmountable problem. The poor support from VNAF helicopters is compounded by their lack of availability due to excessive down time.

d. Engineer. Engineer support for 1st Division combat elements is adequate. The combat engineers of the division are employed in an amazing variety of tasks ranging from road building to the construction of staff offices, and regardless of the scope of the project, appear to do a highly professional job.

9. COMBAT UNITS: See inclosures 3-6 for a discussion of regimental units and capabilities. The 1st Infantry Division is an exceedingly capable organization. It is capable of performing any mission it may be assigned within the bounds of normal doctrine for divisions of its type. The present division commander and his key leaders and staff officers compose a body of men who are cognizant of the capabilities and limitations of the men and machines available to the Division for the conduct of combat operations.

10. COMMAND AND CONTROL: a. How implemented. Command and control in the 1st Division is relatively unsophisticated. It is implemented almost exclusively

15'

CONFIDENTIAL

CONFIDENTIAL

Debrief Report, 1st Inf Div

through command channels with little staff influence. Once a decision has been reached by the CG, delegation of authority to regimental commanders for execution is nearly total. Many factors combine into what amounts to a basically inefficient, and, at times, counterproductive command and control system. Staff officers are relatively untrained and will not act independently. At division level, the TCC will not react to a given situation unless requested by a commander. This unsatisfactory condition may be attributed to a relative lack of experience in the conduct of coordinated division operations. Staff planning, control and monitorship of coordinated multi-regimental operations has improved; however, it is a vital area which is ripe for additional development.

b. Information Systems (To include battlefield reporting). Information systems parallel the command and control system. Battlefield successes are normally reported personally by commanders who may or may not provide the information through operations channels. In the cases of battlefield failures, reports are often deliberately subdued as well as delayed. Combat reporting is generally poor in terms of accuracy and timeliness. It is difficult to imagine why senior commanders do not realize the disservice accorded their units through distorted and untimely reporting precluding effective decision making and the responsive provision of needed combat support by higher headquarters. Yet, the condition prevails, and seems to flourish as a game of wits.

c. Effectiveness. 1st Division command and control has been effective as evidenced by the successful planning and conduct of I AM SQW 45 and 63. However, it is an extremely superficial system and varies erratically as the personalities vary. Without the continuity provided by a functioning staff empowered with a certain freedom of action to implement the policies and decisions of the commander, it is a dangerously weak area, and may be considered as the most serious deficiency in the division at this time.

10. ADVISORY EFFORT: a. Organization. The advisory team is organized as indicated in inclosure 7.

b. Personnel. Until the reduction in personnel reached the austere levels of the most current TD (1 Dec 72), the team was able to function and perform its mission of providing combat assistance to the major elements of the division. Reduction of team strength to the current manning level seriously degraded the viability of the advisory effort. It soon became apparent that the team's ability to function as anything more than an information collecting agency was doubtful. Concurrent with advisor strength reductions, the diminishing availability of US combat support assets further served to undermine the advisory effort of its most meaningful function, combat assistance.

c. Support. Support for the Advisory team was adequate.

11. OVERALL EVALUATION: The 1st Infantry Division must be evaluated as an

CONFIDENTIAL

Debrief Report, 1st Inf Div

outstanding organization. In many areas the quality of operations meets or exceeds that obtained by comparable US units. This is particularly noteworthy in consideration of the relatively limited assets available to implement comparable doctrine for division operations. The most significant problems are as follows:

a. Command and Control. The system of command and control is too highly personalized. As a result of the system, staffs from battalion through division are reticent, inactive, and generally a large reservoir of talent remains stifled and virtually unused.

b. Battlefield Reporting. Reporting is inaccurate and untimely. These deficiencies result in incomplete or inaccurate views of the tactical situation at various levels rendering the decision-making process cumbersome. Additionally, the responsive provision of needed combat support assets is unnecessarily delayed due to the ignorance of various staffs of the situation.

c. Officer Training. The command and control system stifles staff officer initiative and relegates their function to that of an automaton, i.e., a processor of requests and a collector of information. It is believed that a lack of formal training in the principles of staff and command among all ranks of the officer corps is the primary reason for the generally inefficient system.

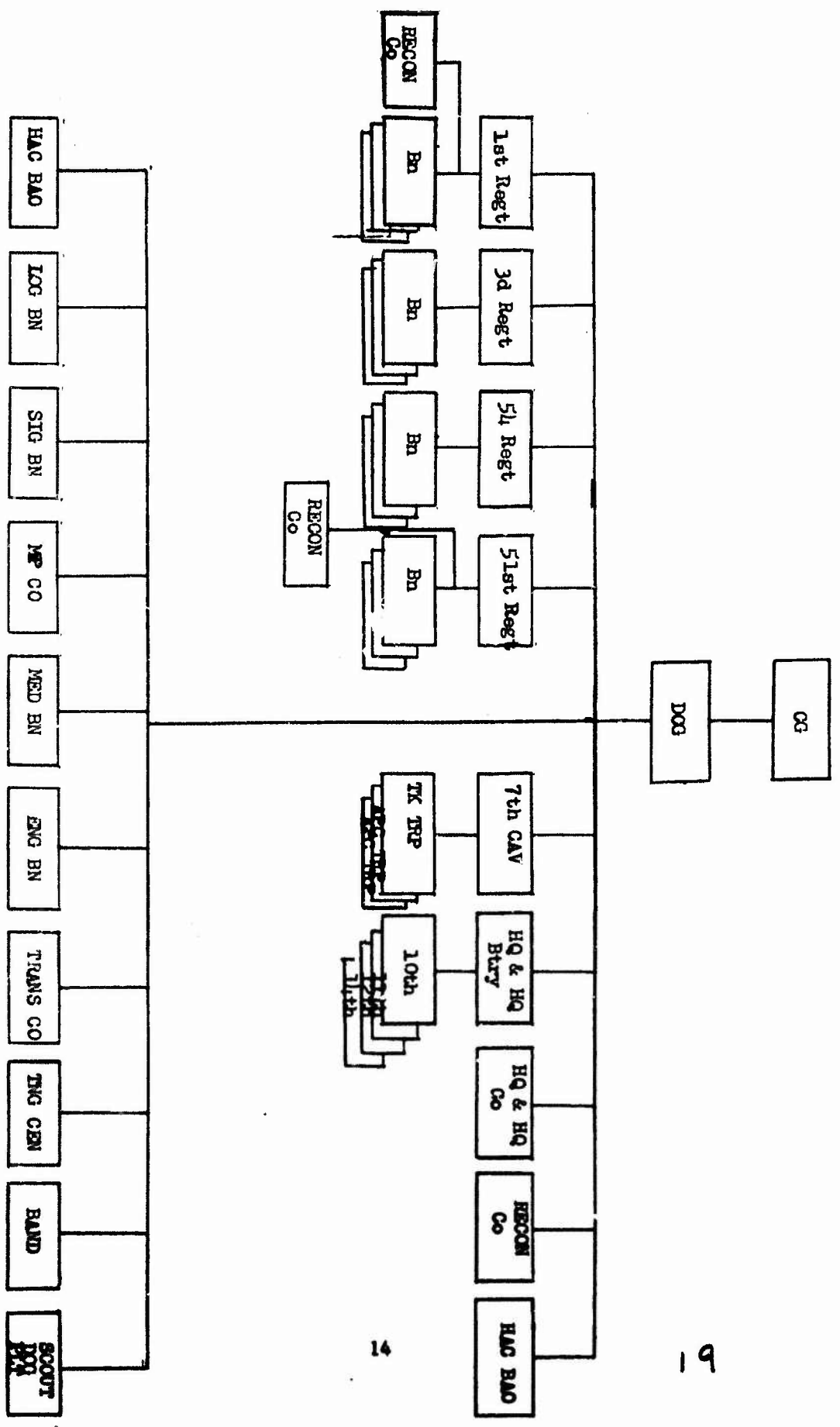

9

14

As of 19 January 1973

		<u>OFF</u>	<u>NCO</u>	<u>EM</u>	<u>TOTAL</u>
AUTH	STR	1105	3438	12,586	17,129
ASSGD	STR	1020	3353	11,384	15,757
WFD	STR	956	3170	10,715	14,841
PFO	STR	876 (80%)	2743 (80%)	10,133 (80%)	13,752 (80%)

CONFIDENTIAL

1st Regiment, 1st Infantry Division (ARVN)

1. INTRODUCTION: As the SA for the 1st Regiment since 24 May 1972, I have observed and participated in this Regiment's outstanding operations which virtually reduced the NVA's 6th and 29th Regiments to combat ineffective status for extended periods of time. The leadership displayed by commanders down through the squad leaders has been most gratifying. Evident by this leadership has been the Regiment's ability to completely win over the enemy in rapid successive operations regaining all territory lost to the NVA in their Spring Offensive from east of FSB Birmingham astride Highway 547 down to and including the area southwest of FSB Veguel.

2. ORGANIZATION: The 1st Regiment has 4 organic infantry maneuver battalions, a reconnaissance company, and a headquarters and headquarters company, with a D/S Arty (105) battalion reinforced with a 155 Army battery. An attached armored cavalry squadron and an engineer company are also present. The Regiment, with its supporting organization, is situated along Highway 547 from FSB Boyd to FSB Veguel. The Regiment since May 1972 has had up to 7 maneuver (inf) battalions, a D/S Arty battalion (reinforced), a cavalry regiment, a tank company (M48), the 1st Division reconnaissance company, and the division Hoc Bao company under its operational control.

3. PERSONNEL: a. The quality of personnel has generally been above the 90% level. However, excessive losses experienced in June-July caused the quality to diminish as a great deal of these losses were experienced NCOs and officers. As of 28 December 1972, a breakout of authorized, assigned and % of fill for officers, NCOs, and EM is shown as follows:

	OFF	NCO	EM	TOTAL
AUTH	142	503	2193	2838
ASSGN	143	522	2033	2688
%	100 +	100 +	93	95

b. The quality deteriorated when the Regiment initiated intensive offensive action. This problem area was somewhat overcome by hospital returnees and the return of experienced personnel from jobs in the rear back to fill positions. Additionally, the quality improved through an intensive training program as battalions stood down at the fire bases for refit and rest. The replacements from the training center as a whole were proved to be fine soldiers under fire. Their major drawback was in their knowledge of jungle warfare which was precisely what they were thrown into right out of the training center. Again, the training program executed by this regiment concentrated on the principle of jungle warfare and brought the replacements up to an acceptable level in minimum time. As a

CONFIDENTIAL

21

CONFIDENTIAL

Not Releasable to Foreign Nationals

1st Regiment (Cont)

matter of necessity, the basics were actually trained while at their fighting positions with a more detailed instructional phase conducted during standdown.

c. Personnel Management: No problems were observed in this area with the over all exception of the usual lack of skilled personnel in the technical fields.

d. Leadership: Leadership in the Regiment is overall the best of what I have observed. The regimental commander is beyond a doubt one of the best commanders in the ARVN. The battalion commanders range from one who is outstanding to the weakest who I consider to be an excellent commander lacking in his ability to rapidly exploit a favorable situation.

4. OPERATIONS: a. Mission:

(1) LAM SON 45: As translated by my interpreter - " control and patrol the high points occupied in the new AO." " Provide security for Nam Hoa." " Initiate operations south and southwest from FSB Birmingham astride Highway 547 to retake the terrain lost to the NVA and neutralize his artillery and rockets in order to prevent him from firing upon Hue and surrounding areas." " To stop his advances into Hue from the south west astride Highway 547."

(2) LAM SON 65: As interpreted - " Maintain terrain reoccupied during LAM SON 45." " Continue limited offensive actions forward of the FEBA to kill the enemy and destroy his logistical bases." " Prevent the NVA from advancing toward Hue and firing arty and/or rockets into the city and surrounding areas."

b. General Concept:

(1) LAM SON 45: The 1st Regiment initially employed 4 battalions in the attack with a reconnaissance company and/or any other attached fighting element providing security for FSB Boyd and FSB Birmingham. Supported by a heavy concentration of air and artillery, the maneuver battalions assaulted one by one the key terrain features which dominated Highway 547 all the way to Dan Cu Mong on the western flank and FSB Veguel on the eastern flank. After the successful assault on the Son Na Mountains, the occupying forces came under intense and prolonged harrassing mortar and arty fire. Sustaining an extensive number of casualties, the concept changed from a conventional type of warfare to a variation called the " Spider Web." Basically this variation changed the conventional attack and defense maneuver into a break up of tactical units down to platoon levels into small 7-10 men fighting cells. A detailed explanation of the " Spider Web " was submitted to the SA previously.

(2) LAM SON 63: The concept was basically the same as that conducted during the operation of LAM SON 45. The emphasis was on holding what we had retaken and establishing a strong defensive line anchored on

CONFIDENTIAL

CONFIDENTIAL

Not Releasable to Foreign Nationals

1st Regiment (Cont)

Hill 542 in anticipation of the impending rainy season which was soon to commence. Between 2 and 3 maneuver battalions were employed on the critical terrain features with the mission of conducting offensive actions to the south and southwest in order to keep the NVA off balance and destroy his logistical bases. The other 1 or 2 battalions would provide security for the fire bases and conduct training from 10-14 days. Added emphasis was placed on "working with the populace" during this phase. The reconnaissance company was dispatched to Nam Hoa district to work with the RF/PF forces and rear elements of the battalion were assigned specific hamlets in our area of responsibility to work with at night. In both cases, this has been highly successful. Civic action activities were increased as well. In both LAM SONs, the cavalry support concept was to keep Highway 547 open and neutralize any NVA armor thrust within the AO. The cavalry provided convoy support and security and fire base security as well. The engineers cleared the roads of mines, improved Highway 547, constructed roads for resupply through inaccessible terrain, and improved existing fire bases and constructed new ones throughout the operations.

c. The 1st Regiment was responsible for the operations to secure the following key terrain:

- Song Na Mountain Complex
- Checkmate
- Bastogne
- Nui May Nha
- Hill 542
- FSB Binh Dinh
- Dong Cu Mong
- FSB Veguel

The first 4 objectives were taken with a strong aggressive determination on the part of the Regiment's 3rd and 4th battalions. Fierce and tenacious resistance by the NVA was encountered. However, with the support of wall to wall B-52 strikes, the good overcame the evil. The remainder of the objectives were taken by an overcautious series of operations with relative ease. The enemy had simply fled the area leaving an excessive amount of equipment on the battlefield subsequently captured by the 1st Regiment.

d. Plans: The Regiment has demonstrated its ability to plan out tactical operations to the finest detail. There is no major shortcoming in this area.

5. TRAINING: a. General. The training program is superb, well organized, and professionally executed. The program is designed to improve the soldier's ability to fight as a professional in jungle warfare. Mission permitting, each battalion stands down on the average of 7 days each month. During this standdown, training is conducted each day according to a prescribed schedule.

b. Specialized: The Regiment has a staff training team which employs the "hands on" technique of providing training in administrative and logistics down to the company level. Crew drill for the TOW, 106mm ER are

CONFIDENTIAL

CONFIDENTIAL

Not Releasable to Foreign Nationals

1st Regiment (Cont)

periodically conducted on the fire bases. During LAM SON 45, the 81mm and 4.2 mm mortars were consolidated at regimental level where crews from each battalion were refreshed on their employment. All weapons were fired together and crews were trained during critical combat conditions. As the units became more dispersed, the 81mm mortars reverted back to battalion control. The 4.2 mm remained with the cavalry. Other specialized training, e.g., drivers, mechanics, is conducted at higher.

6. LOGISTICS: a. Supply: The source of major items of supply and the supply system in general is functional. The breakdown is the shortage of repair parts and items such as BA 4386 (batteries for PFC 25/77), ponchos, helmets, and liners, and compasses to name a few. This is no unique problem only to this Regiment. It is and has been prevalent throughout. Providing bullets and beans to the fighting forces has been outstanding in this Regiment. There has been some instances of delayed resupply but this was due to the weather or the inability to deliver the resupply by VNAF. In each case, the resupply was man packed from the nearest delivery point by the battalions to the squads in the field.

b. Transportation. With the exception of VNAF helicopter support, only minor problems have existed in this area.

c. Maintenance. A shortage of spare parts for the vehicles has been the major obstacle in this area. Until the ARVN quit relying on their spare parts coming from the Black Market and clamp down on the loss of the spare parts to the black market, the situation will not improve.

7. COMMUNICATIONS: Major discrepancy is their complete disregard for communications security. Shortage of batteries require use of batteries in the radio PFC 25 for over 7 days.

8. COMBAT SUPPORT: a. Arty. Responsiveness of arty is generally slow. More emphasis should be placed down at the firing battery level. Abandonment of serviceable ammo has been a major problem; however, strong pressure has been exerted in this area causing the improvement in ammo recovery.

b. TAC Air. Main problem is the lack of qualified personnel at company level to communicate with the US FAC.

c. Aviation. Tighter control of VNAF support is required before any appreciable improvement in the support needed is noted.

d. Engineer. Exceptionally good. The engineer support has included road improvement, road construction, mine clearing, demolitions, and base defense construction.

9. COMBAT UNITS: a. Capability. Each battalion is capable of conducting sustained combat for indefinite periods of time as long as resupply is made each 4-6 days. During intense rainy weather, elements operating in inundated areas should be rotated within 5-7 days in order to sustain morale and health.

CONFIDENTIAL

1st Regiment (Cont)

b. Evaluation: 1st Regiment overall, outstanding.

1st Bn - Excellent

2nd Bn - Excellent

3rd Bn - Outstanding

4th Bn - Outstanding

c. Adequacy. During war, each regiment should have 4 battalions TO&E. The number of personnel and types of weapons are adequate. Weapons should remain light and simple. Sophisticated weapons such as the TCW will become unserviceable over a period of time without US advisor's prodding them to get their batteries charged, etc.

d. Requirements. None recommended at this level. The breakout of weapons TO&E to this regiment are ideal for this environment.

10. **COMMAND & CONTROL:** a. Basically the Command and Control is conducted on a daily basis by radio. Being fully aware of the NVA's capability to monitor the non-secure transmissions, minimum essential traffic is transmitted. Periodic visits to the field by the Regimental CO, Deputy, or messenger relays detailed instructions to the battalion COs.

b. A tactical operation center operates 24 hours daily to receive reports from the field as well as to dispatch instructions to units in the field. The TCC maintains constant radio and telephone contact with the 1st Division TCC. The AK AC Code is the basic instrument used to receive and transmit sensitive reports. It should be mentioned that reporting between 0300 hrs and 0700 hrs is very poor to nonexistent. This has been brought to the attention of all concerned but the situation has not improved.

c. Effectiveness of this system is adequate but not outstanding. The system is definitely compromised by the NVA. The ARVN is aware of this but through the years not much progress has been made.

11. **ADVISORY EFFORT:** a. The organization and personnel is made up of 1 Senior Advisor.

b. Support from ARVN and Team # 3 has been outstanding.

12. **OVERALL EVALUATION:** This regiment has demonstrated its ability to conduct operations in an outstanding manner when compared to other ARVN regimental level organizations. Major problems do exist at the junior officer and NCO levels. This can be attributed to the losses sustained since April 1972. The problems are not necessarily from the lack of good training. Spare parts and lack of enough items such as batteries for PRC 25 radios continue to be a major concern. Nine out of 15 2½ Ton trucks are down due to lack of spare

CONFIDENTIAL

Not Releasable to Foreign Nationals

1st Regiment (Cont)

parts. Communication security will continue to be a problem because the typical ARVN soldier does not seem aware of the problem. The loss of US Advisors will not materially degrade their effectiveness. An area which the advisors will be missed in is the US air area. Both Air Cavalry and US TAC air will need US Advisor assistance if they remain in the war area.

13. SUMMARY: The 1st Regiment has been the vanguard for the 1st Infantry Division's offensive action against the NVA since May 1972. It has proven on numerous occasions that it is capable of accomplishing any mission assigned. Its "can do" attitude has been an inspiration to other organizations in the Division. Given the logistical support necessary, this regiment will continue to display the traits of an outstanding fighting organization for which it is noted today.

CONFIDENTIAL

CONFIDENTIAL

Not Releasable to Foreign Nationals

3rd Regiment, 1st Infantry Division
(ARVN)

1. INTRODUCTION: This report covers the period shown above or the 3rd Regt, 1st ARVN Div. Organization, capabilities and limitation during said reporting period.

2. ORGANIZATION: The 3rd Regt is organized as shown below: RECON CO. Detached to from Hoc Bou Co. 4th Bn (Provisional Bn formed from enternal Issely. No complete HQ Staff.

b. The primary operational area has been the Northern portion of the Divisional sector bordered by the Song Bo River. The Regimental CP is located at FSB T-Bone (Y) 653203 Primary Bn CP location at Semi-permantel aoupost are King (YD 623114) lion (YD 600189) Nui Mu Tha (YD 601103) and Hill 362 (YD 596121). The Regimental rear is located at FSB Sally (YD 637273).

c. The Artillery Support of this regiment is provided by the 14th Arty Bn (105) and one Btry 10th Arty 155. Primary Arty locations during this reporting period were as follows:

- (a) HQ Btry's one firing bly 105 at T-Bone.
- (b) One firing btry (105) at Lion.
- (c) One firing Btry (105) at Sally.
- (d) The 155 Btry primary location was at T-Bone. However, on certain occasions the Btry or projections of the 155 brty logs moved to lion to support tactical combat operations

3. PERSONNEL: a. Strength. The following is an average man strength of this Regiment I must be realized that strength vary from day to day forvarious reasons.

	AUTHOR		ASSIGNED	
	OFF	EM	OFF	EM
HHC	30	203	27	191
Recon Co.	9	102	3	96
1st Bn.	29	636	30	514
2nd Bn.	29	636	35	494
3rd Bn.	29	636	29	514
4th Bn.	15	462	22	461

TOTAL

b. Quality. The quality and training of the personnel of this Regiment seems adequate. Staff procedures as known by

CONFIDENTIAL

27

CONFIDENTIAL

Not Releasable to Foreign Nationals

3rd Regiment (Cont)

the US Army are not followed however, the capability of the commander and staff seemed adequate in the accomplishment and the regiments mission as well as the accomplishment and the 1st ARVN Division mission.

c. The Leadership and the Officers of the Regiment seems adequate. Listed below are the Key Commanders.

- (1) Regt CO: Col Nguyen Bui Quang (39 years old)
 - a. Dalat Academy graduate, class 10
 - b. Assumed command April 1971
 - c. Native of Hue City
 - d. Past Experience, Bn CO, District Chief, Regt S-3, Regt XO.
- (2) Regt XO: LTC Nguyen Phu Tho
 - a. Dalat Academy graduate, class 16
 - b. Native of North Vietnam, Family now resides in Saigon.
 - c. Buddhist
 - d. Post experience Co CO, Bn XO, Bn CO.
- (3) 1st Bn CO: Maj Phan Thanh Tri
 - a. Dalat Academy graduate, Class 20
 - b. Assumed Command 8 May 72
 - c. Native of Hue
 - d. Buddhist
 - e. Past experience, Co CO, Bn XO
- (4) 2nd Bn CO: Maj Phan Jan Thoai
 - a. Dalat Academy graduate, class 16
 - b. Attached US CGSC
 - c. Assumed Command Aug 72
 - d. Native of Siagon
 - e. Buddhist
 - f. Past experience Co CO, Bn S-3, Bn XO
- (5) 3rd Bn: Maj Le Van Can
 - a. Tu Duc officer School Class 16
 - b. Assumed Command 8 Sep 71
 - c. Native of Siagon
 - d. Buddhist
 - e. Past experience Co CO, Bn XO
- (6) 4th Bn CO: Cpt Nguyen My
 - a. Tu Duc Officer School
 - b. Assumed Command Oct 72
 - c. Native of Dalat
 - d. Buddhist
 - e. Prior Experience Plat ldr, Co XO

CONFIDENTIAL

28

CONFIDENTIAL

Not Releasable to Foreign Nationals

3rd Regiment (Cont)

c. Personnel Management. The personnel management of the battaion is concerend exellent. The Regt Commander has always in phe past expressed great care and concern in the assignment of per-sonnel throughout the regiment.

4. OPERATIONS: a. The operations of the regiment during the reporting period was to block enemy infultration toward Hue city. Daily small unit patrolles were conducted to search and clear the regiments assigned AO.

b. The present regimental AO, see over lay.

c. There were no significant contacts during this reporting period. Contacts made were primarily squad or smaller size actions.

5. TRAINING: The training of the individual whier tactically and considered adequate. During the stand-down period of each battaion the regimental commander instituted a retraining pogram in individual, small unit, all weapons training.

6. LOGISTICS: a. The logistical program throughout the heshalim is considered Generally good in the are of supply and transportation. However they are a few shortfalls in the area of maintenance, and supply economy.

b. Maintenance of weapons was considered good by 2 or 3 echilon personnel but poor by the individual soldier.

c. Maintenance of Ammunition was Considered poor. How- ever, some emprovement has been made.

7. COMMUNICATIONS: The Communications capability of the regiment is considered excellent.

8. COMBAT SUPPORT: a. Artillery. The Artillery support provided this regiment is knsidered excellent. Mantance of Artillery units in Direct Suppob of the Regiment were excellent, However, expenditure of Ammunition at time a was considered wastful based in the type used and situation.

b. Other combat suppot activities were considered excellent with the exception of Helicopter suppott, which i feel was unsatis- factory and in some cases hindered the regiments ability to accomplish its assigned mission.

9. COMBAT UNITS. The combat elements of the regiment are considered excellent. If forced to rate their effectiveness I would rate them as follows:

- 2 3rd Bn
- 3 4th Bn (Prov)
- 4 1st Bn

CONFIDENTIAL

29

CONFIDENTIAL

Not Releasable to Foreign Nationals

3rd Regiment (Cont)

10. During my tenure here I saw no problems in command and control.

11. ADVISORY EFFORT:

- a. Organization - one - OK
- b. Personnel - one OK
- c. Support - Adequate

12. OVERALL EVALUATION: I consider the 3rd Regiment one of the best Regiments in the 1st ARVN Division. The most significant problem noted was in due care of maintenance, which I feel the regiment has made significant progress.

CONFIDENTIAL
25

30

CONFIDENTIAL

54th Regiment, 1st Infantry Division (ARVN)

1. INTRODUCTION: During the past six months the 54th Regiment has participated in operations Lam Son 45/72, Lam Son 63/72, and is currently conducting Lam Son 1/73. On 20 July 1972 the Regimental CP moved to FSB Birmingham to control two of its manoeuvre battalions located astride the 547 approach route to Hue. The Regiment, limited by manoeuvre room and lack of manoeuvre battalions, met heavy resistance from advancing elements of the NVA 324 B Division but managed to hold positions in the vicinity of FSB Bostogne. After suffering heavy casualties in the forward elements, the Regimental CP and one battalion were ordered to move to Camp Eagle (Nguyen Hue) on 6 August 72 for refitting and rest. On 18 August 72 the Regimental CP moved to FSB ARSONAL with two battalions operating west and south-west, one battalion OPCON 1st Regt., and one battalion located at Camp Eagle for base defence. During this period enemy pressure abated and the effectiveness of Regimental operations greatly increased. On 19 September 1972 operation Lam Son 45/72 terminated and Lam Son 63/72 was initiated. The Regiment regained its 4th Battalion and conducted successful operations in the vicinity of Chuc-Mao mountain and Garman's Road Extension. On 4 Nov 72 the Regiment was moved to FSB Anzio (La-Son) in response to enemy pressure in the Phu-Loc area. The successful mechanical ambush techniques along Highway 1 and operations west and South-west of Anzio increased the confidence of the Regimental commander and his subordinates and thus greatly increased effectiveness throughout the entire scope of Regimental Operations. On 1 Jan 73 the Regiment assumed responsibility for the 51st Regiment's AO and on this date is continuing operations from Loc Bon village along the length of Highway 1 to vicinity of Lang Co with all four of its organic battalions.

2. ORGANIZATION: By TOE the Regiment is comprised of a Headquarters; three infantry manoeuvre battalions and organic support units however, the regiment continues to retain a fourth battalion that TOE wise was deactivated 31 March 1972. The regiment refers to this battalion as a combat force hence a XK designator is used instead of referring to a fourth battalion.

3. PERSONNEL: a. Strength. The authorized strength of the regiment is 2,822. As of this report the strength is 2,457 with the 3 line battalions averaging approximately 550 and the force battalion approximately 450. The regiments strive to fill 500 men in each line battalion and 425 in the force battalion.

b. Quality. (1) Training. As a result of heavy casualties during the first six months of the year, the regiment lost many of its combat wise leaders. Training was, in effort, conducted in the fox hole during the period July-August, however the regiment began in

CONFIDENTIAL

CONFIDENTIAL

54th Regiment (Cont)

September to conduct formal training as it rotated one battalion to the rear for a ten day period approximately every thirty days. A committee of seven officers was formed to assist this battalion in formal training. As of this report there are 53 personnel in a special training & school for NCO's. An additional 22 personnel are attending an engineer (demolition-type) training course, 5 NCO's are being trained in security operations, and 2 in the operation of the TOW system. (2) Leadership. Initially, leadership within the Regiment was practically nonexistent as a result of many factors. This included extreme pressure brought about by heavy combat losses and disention within the Regimental command group and between the Regimental commander and some of his subordinate commanders. LTC Nguyen Thanh Hanh, the Regimental Commander, was ineffective as a result of this multitudes of problems. However, with enemy pressure greatly reduced beginning in September and personnel changes within the command group as well as battalions, a more confident if not able leader began to emerge. As of this report LTC Hanh is firmly in command and although I'm certain there are more able commanders, he has demonstrated that he has the capability to be an effective if not slightly above average commander. The Regimental XO LTC Dai (former 3rd Bn Commander) is a strong leader and exhibits a fierce aggressive spirit. His assignment as XO has been a major factor in the improvement of Regimental Operations. The first battalion is commanded by Major Hung, a quiet and stable leader, with a great deal of combat experience at platoon and company level. Although not as aggressive as other commanders, he should improve with experience. Major Xuan Commands the 2nd battalion. He is the only commander to have been retired throughout this reporting period. Twice wounded during the period, he exhibits more experience and professionalism than the other commanders but is not as aggressive. However, the 2nd Battalion is second in the Division for the year as far as enemy KIA and weapons captured. The third battalion is command by major Chin (former 1st Bn XO). He is young and very aggressive but lacks experience. This battalion should improve as experience is gained. Captin Quang commands the XK or force battalion and is the most aggressive and competent field commander. His battalion "live's" for combat operations but tends to be undisciplined in a garrison situation. Overall this battalion rates as the strongest within the Regiment for this reporting period. Leadership and demonstrated performance on the part of all commanders has greatly improved during the later half of this reporting period. The Regimental Commander demonstrates a marked concern for the welfare of his troops and a fierce drive to improve the Regiment so as to insure the freedom of his country.

c. Personnel Management. The regiment has sound personnel management procedures and has been able to implament a more liberal leave policy now that enemy pressure has been reduced. The desertion

CONFIDENTIAL

54th Regiment (Cont)

rate was fairly high early in the period during heavy combat but through policies and procedures initiated by the Regimental CO has been reduced to the lowest in the division for the past few months. The Regiment has the highest reenlistment rate in the Division. From an early situation of low morale and spirit, the Regiment has rebuilt and currently demonstrates high qualities in these areas.

4. OPERATIONS: a. Goals (Missions) 1. 20 July-6 August. The Regiment's mission was to block the enemy drive along the northern side of approach route 547. (2) 18 August-3 November. The Regiment's mission was to engage and defeat enemy force in the assigned AO with the Regimental CP located at FSB Arsonel and battalions displayed to the south and south-west. (3) 4 November-1 January 73. The Regimental CP moved to FSB Anzio with a primary mission of moving security to the low lands and highway 1 in its assigned AO, disrupt enemy lines of communications and engage and destroy enemy forces located in the jungle and mountain areas. (4) 1 January-Present. Regimental mission remains the same as previous period but the redployment of the 51st Regiment forced the Regiment to assume an extended AO.

b. General Concept. The Regiment has changed AO's four times during the reporting period. During the first half of the period the Regiment normally had command and control of only two maneuver battalions with a third battalion under Division control for base camp defence and the fourth battalion opcon to another Regiment. The later half of the period found the Regiment in control of three battalions and occasional all four Battalions. When three or four battalions are available the Regiment attempted to rotate one battalion from field operations to base camp defense (Camp Eagle) for rest, refitting and retraining for approx 10 days every thirty days. Currently all four battalions are employed in the extended AO.

c. Summary of Operations of note. The Regiment's effectiveness began to increase during operations in the Chuc-Mao mountain area and along Garmans road extension during September and October. In November, with redeployment to a familiar area of operations in the vicinity of FSB Anzio, the Regiment utilized its extensive knowledge of the terrain and the enemies known mode of operation to initiate several successful mechanical ambushes. In addition, operations elsewhere in the low lands and piedmont area of the AO proved lucrative as commanders effectively utilized knowledge of the AO and retained the initiative against a less aggressive enemy. The Regiment's ability to operate in the lowlands amongst the population is of particular note. They have demonstrated effectively an ability to operate in populated areas, co-existing with the populace in such a manner, so as to encourage the flow of information on enemy movements and for gathering activities which has greatly reduced the enemies operations in the AO. Their civic action and mode of operation in populated areas is to be commended. A review of statistical data on enemy KIA and weapons captured versus losses on the friendly side for the calendar year finds the Regimental in a favorable position compared to the other regiments.

CONFIDENTIAL

54th Regiment (Cont)

Enemy	<u>KIA</u>	<u>Wpns Captured</u>
	4,825	1,265
Frindly	333	886

The accuracy of reporting will be discussed in a later paragraph.

d. Plans. The Regiment continues operations Lam Son 1/73. Future plans are unknown at this time.

5. TRAINING: Previously discussed under paragraph 3.b.1.

6. LOGISTICS: a. Supply. Are areas of supply adequate with the exception of repair parts. The S4 was replaced with a more competent individual recently and the entire logistical effort of the Regiment has greatly improved.

b. Transportation. The Regiment is limited in its transportation capability due to a shortage of 2½ ton trucks and repair parts for on hand but dead lined vehicles.

c. Maintenance. Generally combat equipment is maintained at adequate levels. However until recently, with the exception of command vehicles, vehicle maintenance left much to be desired. The new S4, Major Chau, has initiated an improved maintenance program to include weekly inspections which should improve vehical maintenance.

7. COMMUNICATIONS: The Regiment has on hand sufficient authorized communications equipment and experiences no major problems in maintaining continuous communications. However, communications procedures are weak and communications security is very lax resulting in possible enemy monitoring of Regimental plans and orders.

8. COMBAT SUPPORT: a. Artillery. The 12th Artillery battalion is the normal DS battalion for the Regiment. The commander insures that fire support planning and utilization is highly organized and responsive to Regimental needs.

b. Tactical Air. Tactical air during the initial period of this report was used very ineffectively. Control was weak and target planning did not exist. After a period of retraining, effectiveness increased and the Regiment is fully capable of planning for and employing TAC AIR to support all forms of Regimental operations.

c. Aviation. Aviation assets available to the Regiment in the form of command and control assets are nonexistent. In addition, VNAF resupply and MED-EVAC is very unresponsive.

CONFIDENTIAL

54th Regiment (Cont)

d. Engineer. Engineer assets, when available, are effectively employed.

9. COMBAT UNITS: a. Capability. All manoeuvre battalions are fully capable of performing their combat mission.

b. Evaluation. The XK or Force Battalion is the most effective unit in field operations. The 2nd Battalion performs well in the field and ranks first in over-all unit performance. The 1st and 3rd Battalion can effectively conduct all operations and are improving as their commanders gain additional experience.

10. COMMAND AND CONTROL: a. How implemented. There are two daily staff meetings held by the commander to keep abreast of daily operations. The commander has gained effective control of the unit and his subordinates route to plans and orders in an intensive and effective manner. The weakest link within this area is planning. Several periods of formal instruction were presented to the commander and his staff by the advisory team on staff planning and organization but this area is still in need of improvement. Initially, the commander made little effort to check on subordinate units, however, after constant urging on the part of this advisor as to the necessity and value, a definite improvement has been noted. The limiting factor, as previously mentioned is the non-availability of a C;C aircraft which greatly limits the commander's radius of effective control.

b. Information systems (to include battlefield reporting). Units reports are made fairly rapidly but somewhat sketchy. The Commander demands to be kept informed at all times by the Regimental staff of all reports and this appears to be accomplished effectively. Overall reporting from lower to Regiment and from Regiments to Division is too superficial. This area has been discussed with the commander but improvement is still needed. Battalion reporting appears to be inflated. Of the specific instances witnessed by this advisor the reports on enemy KIA were double the number of bodies actually viewed. However, insufficient examples have been witnessed to establish this as an accurate ratio. This area has been mentioned to both the commander and staff members with the result being an inscrutable smile and an indication that the count includes those believed to have been wounded.

c. Effectiveness. As previously mentioned staff coordination and planning are still weak areas. The commander could do much to improve the staff planning and has in fact taken steps to do so. With a stronger S3 and the Regimental XO'S assistance it is believed this area could be greatly improved. However, the S3 currently assigned lacks sufficient drive and the XO is habitually located in the light CP and unable to assist in the improvement of staff coordination.

CONFIDENTIAL

54th Regiment (Cont)

11. THE ADVISORY EFFORT: The Advisory effort which initially consisted of a three man team has subsequently been reduced to the Senior Advisor. It is the belief of this advisor that the 54th Regiment can effectively conduct all combat and combat operations without US support or Advice.

CONFIDENTIAL

CONFIDENTIAL

51st Regiment, 1st Infantry Division (ARVN)

1. INTRODUCTION: At the time this Advisor joined the 51st Regiment in June 1972, it was I Corps Reserve and a separate regiment. It had operated four months prior to our assignment without an advisor team due to its excellent combat record and the strong and capable leadership of its Commander, COL Truong Tan Thuc. A team was reactivated due to the critical situation which developed in I Corps during March and April 1972 and the likelihood that US Army and air assets would increase in the Regiment's AO. It became apparent that the 51st was experienced in coordinating US assets of all types and was receiving adequate support from both ARVN and US units. In the Quang Nhai area, 30 miles south of Da Nang, in June, the regiment's battalion's activity increased as they engaged NVA units and successfully restored the situation in a 4 week period. In anticipation of a drive to recapture Quang Tri City and surrounding hamlets, the 51st Regiment was ordered north of Hue to the vicinity of the My Chanh River, still I Corps Reserve, but OPCON to the Vietnamese Marine Division. While in this capacity, only small contacts with enemy sapper type units occurred. The Regiment was then relocated south of QL 1 to assist the 1st Division with the serious threat to Hue coming from the Highway 547 axis. The 1st Battalion of the 51st was made OPCON to the 1st Regiment, 1st Division who was bearing the brunt of the enemy effort, while the 51st took on the mission of screening the area to the left of the 1st Regiment. Small contacts developed with no difficulties encountered. The establishment of new regimental boundaries caused the 51st to move several times within the 1st Division AO and then on 1 September, the Regiment was permanently assigned to the Division. All during this period, the 51st performed satisfactorily. The combat units moved aggressively and made good use of supporting units. As a result, NVA units never had the initiative and in fact were kept off balance, forced to react to the constant pressure that was always hitting from these encounters which weakened the enemy to the point where they were forced to break contact. In September, the 51st moved to the area around FSB Anzio with the mission of preventing interdiction of QL 1 which was a daily threat and prevention of enemy capture of food in the lowlands. Deep penetration into the hills by 51st elements again forced enemy units to withdraw and active patrolling and ambushes seemed to prevent any serious disruption along QL 1. One of the primary means of achieving this success can be attributed to the excellent support that the Regiment's soldiers established in the civilian communities. Civic action resulted in gathering good information leading to successful ambushes. Several CAs were conducted in an effort to force contact of large size enemy units but did not realize any great success. These operations did however demonstrate the ability of the units to effect coordination. Small contacts were the norm until November when a large enemy force moved into and occupied a hamlet on QL 1. Poor reaction due to improper coordination and communications between the 51st and sector forces caused many enemy to escape what could have been a complete defeat. A lesson was learned in command and control however and hopefully will not be repeated in the 51st. Advent of Cease Fire talks in Paris in November and December saw a near cessation of contacts and only minor activity is taking place at this time.

32

CONFIDENTIAL

37

CONFIDENTIAL

51st Regiment (Cont.)

2. ORGANIZATION: The 51st is organized into a HQ Co, Recon Co, and 3 combat battalions. Without advisors at battalion level, it is difficult to evaluate the effectiveness of the battalions Hq control over its four rifle companies. In light of the shortage of experienced staff officers at battalion level, (Example, 2nd Lts, S-3s), proper coordination and control probably suffers somewhat. The Recon Co is a valuable asset and because of the highly trained people in it, it can, and has, performed missions not possible to units many times its size. HQ Co seems adequately organized to support the Regiment's needs.

3. PERSONNEL: a. While the 51st was a separate regiment, its strength was maintained in the high 90 percentiles. When the unit moved from Da Nang to the Hue area, high desertion rates were a constant problem and recognized as such. Efforts are being made to swap people from other units to solve the problem but to date it still exists. The S-1, under the constant vigilance of the Regimental CO, seems capable of performing his duties and the replacement flow is good.

b. Quality. The Regimental staff is under ranked but again, the tremendous knowledge and thoroughness of the 51st CO precludes and big problems from this. The support personnel in the HQ Co are up to their responsibilities. The Recon Co is in the best shape with seasoned officers and EM. Lack of officers and NCOs in combat battalions are the greatest weakness in the 51st. Although the 3 majors who now act as Battalion COs seem to do good jobs, much of it is due to the supervision and firm guidance of COL Thuc. They must be given their due however because as mentioned earlier, they have relatively inexperienced officers in their staffs. This problem to some degree stems from non-assignment of CoIs to Col slots and the subsequent necessity to place lesser ranking officers in slots for which they are inexperienced. This situation goes down to the lowest levels. COL Thuc is a true professional. Very knowledgeable and with a good ability to get the most out of his people. He takes an interest in all aspects of his command and his calm, assured manner maintains a well ordered headquarters under all conditions. He likes the army and is a very loyal individual to his military and civilian leaders alike. His worth is recognized by his superiors and they frequently value his opinion enough to ask for it.

c. Personnel Management. Not too many problems. Men get their pay but it isn't sufficient especially with the higher cost of living in the Hue-Da Nang area. Dependents are locked after on a continuous basis, and except for the deserter problem due to men assigned away from the vicinity of their families, no problems exist in the 51st that are not common to all ARVN. Movement of dependents from Da Nang to the Phu Bai area would no doubt improve morale were it possible, but lack of jobs preclude it.

4. OPERATIONS: a. Goals. To contact NVA and VC units, destroy them, and preclude mass movement of such units into lowland populated areas. To insure uninterrupted use of QL 1 in its AO.

CONFIDENTIAL

51st Regiment (Cont)

b. General Concept: Move units deep into the mountainous area south of QL 1 to preclude enemy observation and interdiction. Destroy enemy supply points and deny him bases near the populated areas from which he can make fast surprise sallies. Maintain good rapport with civilians to gain their confidence and information and work closely with RF/FF forces in the AO to provide mutual support. Establish a fast reaction force to counter any sizeable enemy force which establishes a foothold in the area.

c. Summary of Operations of Note. June - Quang Nhai - Enemy forces of company size had succeeded in moving into the populated area to capture rice and maintain active control. Heavy contacts resulted in fierce fighting taking place in well prepared enemy positions. Numerous arty and air strikes were called in but due to the rocky terrain and well located bunkers, the enemy had to be dislodged mostly by ground attacks. While OPCON to the 2nd Division during this brief 3 weeks, the 51st established the best kill ration of all the regiments involved. Nothing significant until around August. Heavy contacts around Liop and south of Lion. Contacts led to discovery of vacated regimental CP and from knowledge that supplies were cached in the vicinity. Operation results were a cleared area and denial of terrain critical to an enemy effort to move in strength towards Hue. From September to December, operations east of Hue between Phu Bai and Lang Co to protect QL 1 and deny food supply to enemy were not noted for large contacts with exception of the 2 day occupation of a hamlet by an NVA battalion. Enemy refusal to attempt contacts resulted in most activity occurring at night when ambushes were most successful. Phu Bai Installation was turned over to the 51st by US during period 20 October to 1 November. Inventory and turn-over of property between US and 51st was relatively smooth. Apparently, the installation is under observation from the enemy since it has been rocketed with 122s during times when battalions were using it for rest and recuperation.

d. Plans. The 51st will continue missions along QL 1 with emphasis on countering any enemy effort to grab terrain in the event of a Cease Fire.

5. TRAINING: a. General. Battalions have attempted to conduct refresher training but the poor weather conditions have not tended to improve the situation. With the troops living in the field, wet and cold and no adequate place to give the man some semblance of comfort, they cannot be expected to derive any benefit from the training.

b. Specialised. TOW training was conducted on a crash basis when the weapons were signed over to the Regiment. Maintenance was the biggest problem encountered but with the assignment of an officer to supervise and conduct training on a weekly basis, the situation has been corrected. Crews know how to operate the weapon but inability to conduct live firing for extended periods makes it impossible to verify proficiency.

6. LOGISTICS: a. Supply. Inadequate PRC 25 batteries pose the obvious problem of communications. Gas is also limited but can be solved with driving limited to absolute necessities. Rations, ammunition, clothing

CONFIDENTIAL

51st Regiment (Cont)

and weapons are handled in a routine fashion with few complaints.

b. Transportation - Adequate.

c. Maintenance - Regiment is apparently blessed with a good maintenance section. Occasionally spare parts slow up operations but not seriously.

7. COMMUNICATIONS: With the small independent unit operations critical to the Regiment's mission, additional PRC 25s are needed. This is apparent-an impossible request since the present battery quota is inadequate for the number of radios already assigned.

8. COMBAT SUPPORT: a. Artillery - adequate.

b. TAC Air - Adequate but there has been little need for the support of the Regiment during the time I have been SA.

c. Aviation - Air Cav support has been adequate for the most part but due to its heavy commitments it has not been as responsive as would have been best. Missions flown by Cav have been effective but at times utilization of the Cav has been bad. For the most part, COL Thuc has personally reviewed the use of the Cav and results have been favorable.

d. Engineers. Support has been less than desired on a few occasions but no serious problem to date.

e. Armored Cav. Lacking in aggressiveness and apparently little knowledge about its proper deployment. When infantry is requested to clear roads prior to movement of armored cav, something is seriously wrong. Little or no results have been attained during combined operations with the cav due to a " follow the same tracks of the APC in front " attitude.

9. COMBAT UNITS: a. Capability. All 3 battalions and recon co of the 51st are capable of carrying out their missions. They have demonstrated an aggressive nature and have enough combat experienced officers and NCOs to make them a reliable combat force.

b. Evaluation. The 1st Bn and recon co are the most capable in the Regiment. Leadership seems to be the reason for this in the 1st Bn and the " all volunteer " force working in the recon co is its reason for success. It is difficult to be more specific in the appraisal of these units for lack of advisors at battalion level, but each of the units have demonstrated a capability to coordinate with US air and cav units and obtain the necessary results. They all have English speaking individuals who make this possible.

c. Adequacy - All units are adequately trained and equipped to perform their TO&E missions.

d. Requirements. None

CONFIDENTIAL

51st Regiment Cont.

10. **COMMAND AND CONTROL:** a. How implemented: Orders are issued directly from the Regimental CO to his battalion commanders in most cases. He gives his commanders sufficient guidance to insure full understanding of what he wants but does not dictate the methods they must use. Staff members are encouraged to coordinate, especially the S-2s. On occasion, a regimental CP is established when units are operating in a wide front and control is important due to probable contacts. This is also true in cases where RF/PF units are operating in conjunction with a regimental unit. Little command is actually done from these CPs however, and LTC Nhon, the deputy RC is not forceful and does not enjoy the full confidence of Col Thuc. The CP actually performs more as a relay station than as a command. No serious deficiencies have resulted from this situation but Col Thuc is reluctant to absent himself from his CP if the situation warms up.

b. Information Systems. Spot reports are called from battalions into the Regimental TOC. Col Thuc will spend much time talking with his commanders either on the radio or on the ground if the situation permits. S-2s are definitely expected to coordinate and exchange information and this includes lateral units and sectors. Complaints have been made by Division that reports are lacking, late, and inaccurate but to my knowledge, the 51st has been conscientious in its reporting. Battalions and especially RF/PF units have been remiss in this area but I cannot judge the extent.

c. Effectiveness. Down to battalion level, no problem exists, but companies in many cases are commanded by 2nd Lts and many platoons are led by NCOs. At the squad level we can find some major problems in the area of control. As long as control is centralized at company level, no difficulties usually occur but even here we had a case in the 2nd Bn where a small VC unit attacking at night, caused a company CP to panic and withdraw from its night position, along with a rifle platoon. The shortage of seasoned officers and NCOs definitely reduces effectiveness at the small unit level.

11. **ADVISORY EFFORT:** From June to October 1972, the team consisted of a major as SA, a captain as deputy, and an SFC operations sgt. Drawdowns reduced the team to the major and SFC in October and finally to the major in November.

b. Support: Team support has been good since the 51st was assigned to the 1st Division but inadequate while the regiment was a separate entity. During this period, we were dependent upon the favors of anyone who would take pity on us. Our best benefactor even then was the 1st Division.

12. **OVERALL EVALUATION.** The 51st Regiment is able to fulfill its missions with little or no need of a US advisor, but they seem to lack confidence in their own ability at times. Most significant problem is the age old personnel problem.

13. **SUMMARY:** My observations of the 51st Regiment during my 7 months tour with it has led me to believe that it can and will conduct itself in an outstanding manner with or without an advisor. If properly led as it now is by Col Thuc, it will overcome its weaknesses and improve as it goes along.

CONFIDENTIAL 36

4142B

FRAC 1ST INF DIV (ARVN)

EFF 1 Dec 1972

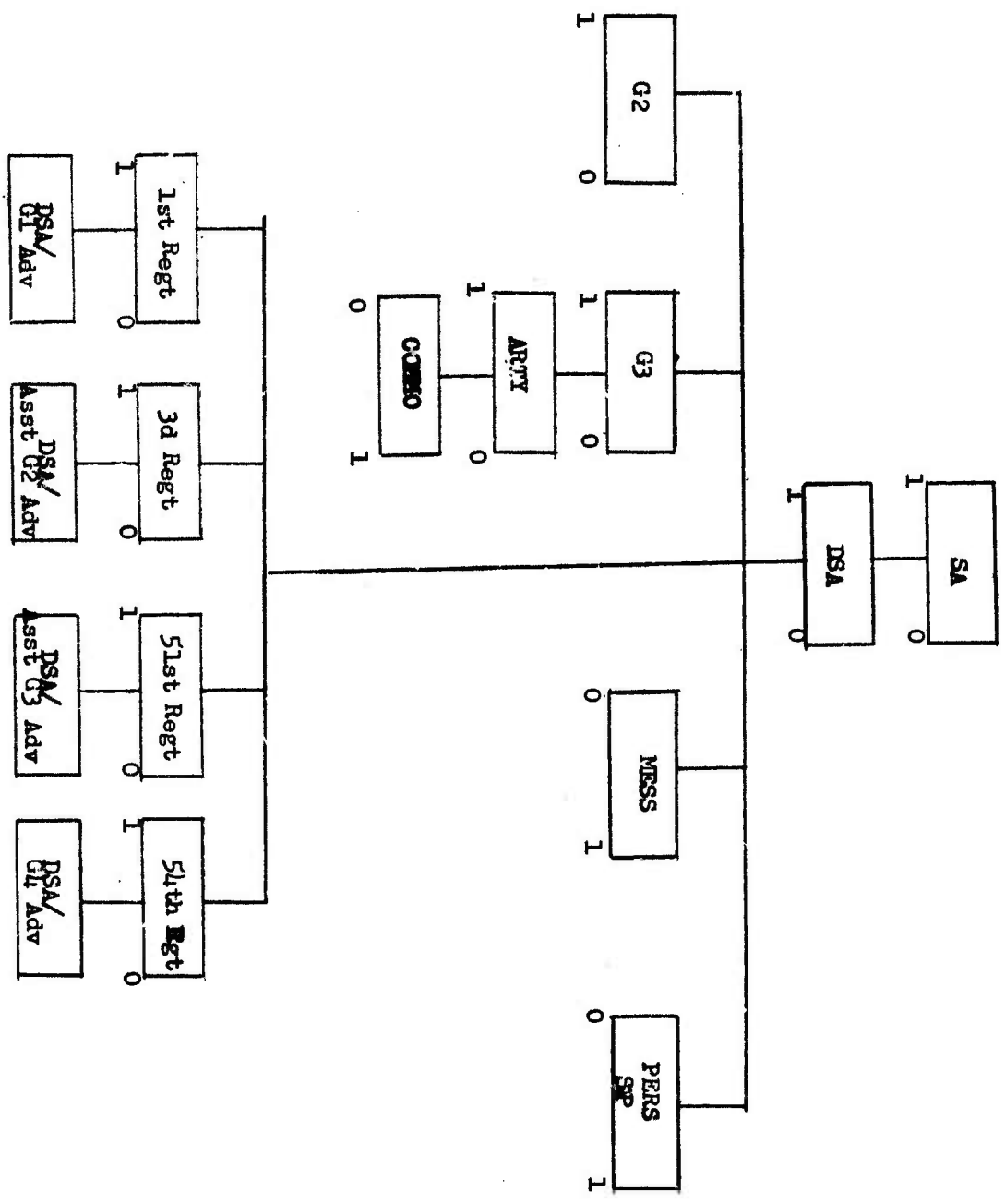

43
44B

CONFIDENTIAL

MACFR-OP (29 Jan 73) 1st Ind
SUBJECT: Senior Officer Debriefing Report

Headquarters, First Regional Assistance Command, AFO 96349, 1 February 1973

THRU: Commander, US Military Assistance Command, Vietnam, ATTN: MACDO-4,
AFO 96222

TO: Assistant Chief of Staff for Force Development, ATTN: FOR OT UT,
Department of the Army, Washington, D. C. 20310

The Debriefing Report prepared by COL George A. Millener, Senior Advisor to the 1st Infantry Division (ARVN), has been reviewed by this headquarters and no forwarding comments are deemed necessary.

FOR THE COMMANDER:

MICHAEL L. GARRIOTT
CPT, AG
Adjutant General

CONFIDENTIAL

HEADQUARTERS
UNITED STATES MILITARY COMMAND, VIETNAM
APO SAN FRANCISCO 96222



16 FEB 1973

MACDO-341

SUBJECT: Senior Officer Debriefing Report (RCS: CSFOR-74)

Assistant Chief of Staff for Force Development
ATTN: FOR OT UT
Department of the Army
Washington, DC 20310

1. Ref: AR 525-14 (C).

2. In accordance with reference as above, the Completion of Tour Report of COL C. B. McCoid, Senior Advisor, 3rd Infantry Division (ARVN), is inclosed. A copy of the subject report has been forwarded to CINCUSARPAC, for information.

John R. McGiffert
JOHN R. MCGIFFERT
Brigadier General, USA
Director of Operations

DAMO-ODU
73B014
Inclosure 2

47 48B

CONFIDENTIAL

CLASSIFIED BY COL C. B. McCoid
SUBJECT TO GENERAL DECLASSIFICATION
SCHEDULE OF EXECUTIVE ORDER 11652
AUTOMATICALLY DOWNGRADED AT TWO YEAR
INTERVALS
DECLASSIFIED ON 31 DECEMBER 1979

CONFIDENTIAL

HEADQUARTERS
MACV Advisory Team 155
3d Infantry Division (ARVN)
APO San Francisco 96349

MACFR-3D-SA

SUBJECT: Senior Advisor's Debriefing Report

Commander
First Regional Assistance Command (FRAC)
ATTN: G-3
APO SF 96349

Debrief Report By: Colonel G. B. McGOID
Duty Assignment: Senior Advisor, MACV Advisory Team 155
Inclusive Dates: 3 June 1972 to 27 January 1973.

1. INTRODUCTION: The period of this report saw the renaissance of the 3d Infantry Division (ARVN) which had been severely mauled in Quang Tri Province by the NVA Spring Offensive of 1972. At the outset it was doubtful whether the remnants of the Division were worth their logistical support. The actions taken to correct this unsatisfactory situation included, inter alia, replacement of personnel and the equipping and training of what constituted essentially newly formed units. As the Division's battleworthiness improved, it was ordered to DaNang and assumed the mission of defending the DaNang Vital area.

Since that event in late June, major activities of an operational nature conducted by the Division have included its campaign to retake Que Son District; recapture of Tien Phuoc District Town; Operation Quang Trung 81 to seize Hiep Duc District Town; and cease-fire preparations.

2. NARRATIVE: Following its hasty evacuation from Quang Tri Province, the badly shattered 3d Division faced horrendous problems with regard to shortages of combat essential equipment and personnel. These were compounded by a state of generally poor morale (evidenced by dirty, dispirited, and undisciplined troops) and by the defeatism exhibited by certain commanders. The new Division Commander, Brigadier General Nguyen Doy Hinh, arrived on 9 June. Within a few days, he completed his assessment of the Division's condition and undertook to get matters into hand. He established stern but evenhanded disciplinary policies and raised markedly the standards of performance by which subordinate units would be gaged.

CONFIDENTIAL

49

CONFIDENTIAL

MACFR-3D-SA

SUBJECT: Senior Advisor's Debriefing Report

The 3d Division underwent an extended period of organizational realignment, rebuilding, and retraining subsequent to its relocation at Phu Bai (Annex A Division Organization). The most awkward among the numerous personnel problems encountered, were the outrageously high ANOL and desertion rates. This situation was aggravated by the assignment of large numbers of men who had been former military prisoners to the Division. Individual records had been lost; this seriously affected the efficiency of pay and other personnel service actions. In addition to combat created problems, there were cases of corruption, as well as inefficiency, due to incompetent personnel performing in these areas. The Commanding General, 3d Division took personal interest in this serious situation. It was his belief that the elimination of corruption and the establishment of a smooth, efficient personnel management system were necessary as a basic foundation upon which to build effective fighting units. He felt that this was one way of gaining increased support and loyalty from his troops. Due to strong command emphasis, personnel management has shown marked improvement throughout the Division. Policies are clear and the interest and support of subordinate commanders in this area have been developed. Additional improvements are required; however, a viable system exists and emphasis continues to be given to this area. The Division Command Section has also taken positive steps to reduce ANOL and desertion rates. These actions are exemplified by the fact that these unauthorized absences have been considerably reduced. Nonetheless, ANOL's and desertions, in combination with losses due to casualties, compose the major existing problem in the personnel field.

Leadership in the Division has improved tremendously since the fighting in Quang Tri. This is exemplified by the noticeable improvement in the capability of the Division to function efficiently in conventional operations; and continued improvement in discipline, morale, esprit de corps, and proficiency (Annex B-Personnel).

Toward the end of the 3d Division's involvement in heavy fighting in Quang Tri Province, the intelligence activities of the Division in effect ceased operations. Since then, marked improvement in its capabilities to plan, collect, process, and disseminate intelligence information has been observed. However, significant limiting factors exist which hinder intelligence operations, the most notable of which is the quality of junior officers assigned to intelligence duties. They lack initiative and require constant prodding and supervision. This problem, of course, is prevalent throughout the Division. Of particular significance for its helpful effect, was a conference held in late July by the 3d Division for intelligence agencies in Quang Nam Province. Attendees included the Commanding General, 3d Division, 3d Division G2, Quang Nam Sector S2, and representatives from Da Nang Special Sector, the 2d, 56th, and 57th Regiments, the Quang Nam Phung Hoang Program, and the National Police. Based on the then existing situation, and those anticipated for the future, Essential Elements of Information (EEI) were developed and disseminated.

CONFIDENTIAL

MACFR-3D-SA

SUBJECT: Senior Advisor's Debriefing Report

The conference represented the first attempt at coordination of the overall intelligence effort in Quang Nam Province, and in fact, was the first such conference held by the 3d Division since its activation. Greater coordination with other intelligence agencies has been a major objective of the advisory effort at the 3d Division for more than eight months, and this conference provided the basis for regularizing the coordination effort in Quang Nam Province. The distribution of EEI also represented an advancement in the coordination effort, as well as in the G2 dissemination effort. Until July 1972, no EEI had ever been developed and distributed in this manner by the Division G2. This conference was only the first in a series of intelligence means, which have been utilized in coordinating with other agencies. These are exemplified by the conduct of liaison visits, exchange of information and estimates, updating of EEI, and conduct of conferences on a smaller scale. Of greatest importance is the emphasis placed by the Commanding General, 3d Division, on operational coordination and cooperation, especially in the area of intelligence (Annex C-Intelligence).

During its initial, post-Quang Tri retraining phase at Phu Bai, the Division conducted a vigorous program for its infantry battalions and reconnaissance companies. This instruction was presented by the MACV Special Forces Mobile Training Team during the period May through August 1972, culminating in six battalions and four reconnaissance companies completing two week training programs. The remaining two battalions are scheduled to receive this same type training at Hoa Can Training Center, near Da Nang, in April 1973. The program of instruction for its units included weapons, tactics, and reconnaissance techniques (Annex D-Division Training). On 19 June 1972, the 3d Division (minus its 57th Regiment which remained OPCOM to the 1st Infantry Division (ARVN) assumed responsibility for its current area of operations. Its assigned mission includes the conduct of operations in Quang Nam Province and destruction of enemy forces and supply bases in the area of operations; supervision and support for the pacification program and area development; prevention of enemy infiltration from Laos; and defense of Da Nang and Da Nang Air Force Base from long range fires. The Division's Command Group re-located its command post (CP) at the 196th Light Infantry Brigade's former base camp, west of Da Nang, on 28 June 72. The Division initially conducted battalion-size operations within its assigned area. Subsequently, the 2d Regiment began a seven day operation on 27 June, the purpose of which was to sweep from the Hai Van Pass into the Elephant Valley, along Highway 545, to the southwest. This effort reduced the enemy threat to interdict QL1, the north-south supply artery between Da Nang and northern MR-1.

On 1 August 1972, the 3d Division was capable of launching limited offensive operations. With one regiment still under the operational control of the 1st Infantry Division (ARVN) and one regiment (the 56th) deployed in the defense of the Da Nang vital area, the Commanding General employed the 2d Regiment in the western portion of the Que Son Mountains with the purpose of attacking the rear of the 711th NVA Division. This operation was the

51

3

CONFIDENTIAL

CONFIDENTIAL

MACFR-3D-SA

SUBJECT: Senior Advisor's Debriefing Report.

first multi-battalion operation conducted by the regiment since the fighting in Quang Tri. The experience gained thereby was to prove of tremendous value in the conduct of future operations. In early September, the Commanding General assumed full responsibility for all of Quang Nam Province (to this juncture, the 2d Division (ARVN) was conducting operations in Que Son District). Soon thereafter he was directed to clear the enemy from Tien Phuoc District, which lay well to the southward in Quang Tin Province. With this expanded responsibility, the Commanding General assigned the defense of the Que Son Valley to the 57th Infantry Regiment, which had returned to Division control on 18 September 1972, and subsequently deployed to Quang Nam Province. The 6th Regiment (of the 2d Division), was placed under the operational control of the 3d Division. This, together with the 2d Regiment, plus one battalion of the 56th Regiment, recaptured Tien Phuoc Town. This operation is especially noteworthy for it was the first multi-regiment operation conducted under Division control since the fighting in April and May (Annex E-Cumulative Results of Operation-Tien Phuoc District Town). On 31 October 1972, elements of the 38th and 270th NVA Regiments of the 711th NVA Division attacked and overran Que Son District Town. The 3d Division which was responsible for the area, conducted a successful counterattack, utilizing the 2d and 57th Infantry Regiments culminating in the recapture of the town and the infliction of heavy casualties upon NVA forces (Annex F-Cumulative Results of Operation-Que Son District Town). Following this successful campaign, the Commanding General established a policy of rotation between regimental assignments in the more active segments of the Division's area of operations. The 56th Regiment was assigned responsibility for the Que Son Valley, the 57th Regiment assumed control of the Da Nang Rocket Belt mission, and the 2d Regiment was held in Division Reserve for mobile operations as ordered. These missions were to be rotated on a three-month basis. In anticipation of a cease-fire, a combined action platoon program was initiated in December to strengthen the Popular Forces in Dien Ban and Hoa Vang Districts. The program's design included not only increasing the military effectiveness of the Popular Forces, but also effective psychological operations programs for GVN proselyting in these heavily populated areas. It has required two ARVN Company equivalents to support. In late December 1972 and January 1973, the 3d Division launched operations Quang Trung 81 and 81/A respectively. These operations took place in the Que Son Valley with the purpose of destroying the 711th NVA Division and recapturing Hiep Duc District Town. The concept of operations was to precede the attack by a demonstration into Antenna Valley, followed by a large scale attack in the Que Son Valley. The attack was planned in multiple phases. The first phase being the demonstration; second phase being the seizure of Firebase Lion and Nui Lac Son; and the third phase called for retaking Hiep Duc District Town. In execution, the first phase was successful in deceiving the enemy and drawing enemy forces into Antenna Valley. The second phase, was initiated on 27 December, utilized the 2d and 56th Regiments, and the 51st Regiment which was under the operational control of the 3d Division. Key terrain features such as Firebase LION and Nui Lac Son were seized and occupied by the 56th and 2d Regiments respectively prior to 2 January 1973. The 51st

52

4

CONFIDENTIAL

CONFIDENTIAL

MACFR-3D-SA

SUBJECT: Senior Advisor's Debriefing Report

attack on Firebase WEST was not successful, for it failed to secure the entire objective and, as of date of this report, the fighting for this important firebase is still in progress. It should be noted that even though the enemy resistance was relatively heavy, the primary reason for the Regiment's failure to seize this objective was the lack of aggressiveness of the regimental commander (Annex G-Cumulative Results of Operations Quang Trung 81 and 81/A).

Efforts to rebuild and reequip the division were initiated with the movement of the Division to Phu Bai and subsequently to Quang Nam Province. Initially, equipment and supplies were difficult to acquire due to a lack of priority. Logistics levels did rise slowly and, under the guiding hands of the Commanding General and the G4, significant advances were made in the reorganizing and streamlining this form of activity. Ultimately, many of the Division's supply, transportation, and maintenance problems were overcome. Quarterly logistical conferences and a Material Readiness Reporting System were initiated. Finally the Division Logistics and Engineer Battalions were formed and are now fully operational. Problems still exist nonetheless; these include, for example, the shortage of communications equipment, a lack of timely reporting of combat losses; a lack of adequate ground transportation (this hinders the movement of personnel, supplies, and equipment during combat operations), and nonexistence of an effective organizational maintenance program. Even with these shortcomings, the Division's capability to shoot, move, and communicate has not been effected too adversely (Annex H-Logistics and Communications).

In the area of combat support, artillery has been extremely effective. All four artillery battalions are adequately trained and respond energetically and enthusiastically to missions. Maintenance however, is a continuous problem; attempts are being made to rectify the situation. US Army Aviation support was particularly outstanding, but as US assets diminish, VNAF and ground transportation will have to fill the resultant void. Engineer support for the Division is especially noteworthy and all elements demonstrate an exceptional level of proficiency (Annex I-Combat Support).

In any assessment of the major subordinate elements of the 3d Division, it is reasonably accurate to say that each is led by an individual who is well grounded in infantry tactics and utilizes fair judgment in employing these. The main difference among the several commanders is their display of varying degrees of aggressiveness and enthusiasm. The greatest failing of all is their tendency to be overly cautious in tactical operations and reluctant to push their subordinates when the situation requires it. When permitted to choose between an aggressive course of action and one that affords less contact with the enemy, they trend to the latter. Notwithstanding this shortcoming, they are relatively effective commanders. Each regiment is capable of performing assigned missions. Of the three major infantry elements the 56th Regiment is the strongest, the 2nd Regiment stands second; and the 57th Regiment is the weakest. Recently however, under the leadership of a new commander, the 57th Regiment will improve

53

5

CONFIDENTIAL

CONFIDENTIAL

MACFR-3D-SA

SUBJECT: Senior Advisor's Debriefing Report

considerably (Annex J-Regimental Assessments).

Command and control techniques varied according to the Division's mission. Prior to assuming responsibility for Quang Nam Province, command and control in the 3d Division was implemented directly through command channels with little staff influence. Once the Commanding General arrived at a decision, delegation of authority was passed directly to regimental commanders for execution. This was due initially to the fact each regiment had an isolated area of operations and little or no coordination was required between regiments or through Division. With assumption of responsibility for Quang Nam Province and conduct of conventional offensive operations against NVA forces, however, changes were required. Since assuming an offensive posture in Quang Tin and Quang Nam Provinces, the regiments have operated in concert proximity against NVA forces. This has required unity of effort and the institution of stringent command and control measures. That the 3d Division has an extremely effective command and control system is exemplified by the conduct of successful operations during the past five months. Especially noteworthy were operation Quang Trung 81 and 81/A conducted in the Que Son Valley. Of considerable importance is the command and control required for the specific mission of Rocket Belt defense, which is unique to the 3d Division, due to the close proximity of Da Nang Air Force Base. As a result, the Commanding General exercises operational control of Quang Nam Sector and Da Nang Special Sector, thus insuring adequate coordination and cooperation in the employment of forces toward the accomplishment of this mission. (It should be noted that this mission made use of the Division's full combat power in a single operation an unattainable objective). (Annex K-Organization for defense of Da Nang vital area).

As far as the activities of the Advisory Team were concerned, efforts were "hamstrung" due to two serious reductions in team personnel. Personnel fill of advisory positions varied from 100% to a low of 94% of authorized spaces. Conflicts between the publicized MACV "120 days DEROS drop for excesses" policy and the actual working level requirements necessitated the reassignment of field personnel to critical logistical and administrative vacancies. The problem became more acute as the withdrawal plan was accelerated. The reduction of the Advisory Team to fifteen personnel (1 December 1972) had a significantly adverse impact on its ability to provide liaison with higher headquarters (Reporting of information) and providing advice to the commander and staff of the Division. Securing clearances for US FACAIR, Stinger, Nighthawk, and gunships; coordinating ARC light requests; etc) and simultaneously to provide advice to the Commander and Staff of the 3rd Division. The quality of advisory personnel appeared to be far above the US Army average, as a result of assignment priorities and of a more senior rank structure. Regimental advisory positions were retained despite reduction in the JTD; however, these teams each were reduced to 2 personnel. Although small in number, the regimental teams were still considered of great value, particularly in the areas of combat support coordination in conjunction with US assets. The mere presence of advisors in the field served as stimulation to command groups. In addition to operations and training, supply and maintenance were important areas at the regimental level where advisory assistance was required. One other important reason

54

6

CONFIDENTIAL

CONFIDENTIAL

MACFR-3D-SA

SUBJECT: Senior Advisor's Debriefing Report.

for maintaining the regimental teams was for the purpose of verification of field reports which, at times, have been inaccurate. As far as the headquarters of the advisory team was concerned, advisory staff functions were combined, such as the G2/G3 Section, in order to attain the maximum effort and effective use of available personnel. Initially, responsibility for administration of personnel belonged to the Headquarters Commandant. With the reduction of team personnel and changes to the JTD, the role of the staff advisors, as pure advisors, expanded to include the normal staff responsibility for advisor support (Annex L--Advisory Team Organization and Annex M--Letter to CG FRAC, Subject: Strength Reductions).

An overall evaluation of the contribution of the advisory team to the 3d Division indicates that advice and assistance pertaining to the conduct of operations and intelligence played an extremely important role during several key campaigns, especially those of an offensive nature. For example, extremely good intelligence pertaining to the location and strength of enemy forces were acquired from US assets and agencies. These proved invaluable in both the planning and execution phases of operations 81 and 81/A. Advice on tactics, accepted and acted upon by the Commanding General of the Division, resulted in the retaking and re-occupation of such important areas as Firebase LION and Nui Loc Son. Additionally, artillery and air support inflicted tremendous losses on elements of the 711th NVA Division, particularly its 31st, 38th, and 270th NVA Regiments. Assistance in the acquisition and effective use of US assets was essential. These involved such support as ARC Lights, Tactical Air, Air Cavalry, and Naval gunfire support. The inadequacy of logistical plans seemed to be the nucleus of logistical problems. Commanders and logistical staff officers were reluctant to prepare estimates and to plan for future operations and/or troop/unit movements. The need for improvement in this area was constantly stressed by the advisory element, resulting in the more adequate logistical planning. Although the requisitioning system was used satisfactorily, improvements were necessary, particularly in terms of follow-up action and the reporting of equipment losses. Equipment replacement, particularly major end items, cannot be obtained unless losses are reported and appropriate actions are taken to determine disposition or to fix responsibility. Follow-up action had to be conducted to insure, not only that the Divisional unit received the required item, but to exercise the system in providing the desired services. Accountability for supplies and equipment was somewhat irregular; this was due to a lack of checks, auditing, and inspections. Assistance provided in these areas proved valuable to the ARVN. Advisory techniques were designed to identify critical problem areas, provide informal advice and suggest solutions, and to follow-up with a memorandum to the Commanding General. When the Commanding General was aware of an unsatisfactory

55

7

CONFIDENTIAL

CONFIDENTIAL

MACFR-9D-SA

SUBJECT: Senior Advisor's Debriefing Report.

situation, immediate corrective guidance was issued, and he insisted that inspections be conducted regularly to determine whether his instructions were being obeyed. Because of his command interest, these advisory techniques were particularly effective. As a consequence of the advisory effort and General Hinh's command actions, refitting of the Division, rebuilding its leadership, and re-establishing the Division as a reasonably effective fighting force took place sufficiently quickly to permit it to contribute to a significant improvement in the level of security in central Military Region I.

3. SUMMARY: Following the 3d Division's defeat and subsequent withdrawal from Quang Tri, it underwent a near "up from the ground" reorganization, training, reequipping, and then conducted a series of reasonably successful minor operations. All of these actions, under the thrust provided by Brigadier General Nguyen Duy Hinh, culminated ultimately in an ability to conduct extensive Joint/Combined Operations. Indications exist that the Division is capable of functioning efficiently in conventional operations against a weak NVA force. It is not prepared, however, for the conduct of extended operations; this is due to shortfalls with respect to personnel strengths, equipment status and logistical support. Despite these deficiencies, the 3d Division has emerged as a reasonably effective fighting force.



C. B. McCOID
Colonel, Infantry
Senior Advisor

CONFIDENTIAL

ORGANIZATION 3D ARVN DIVISION

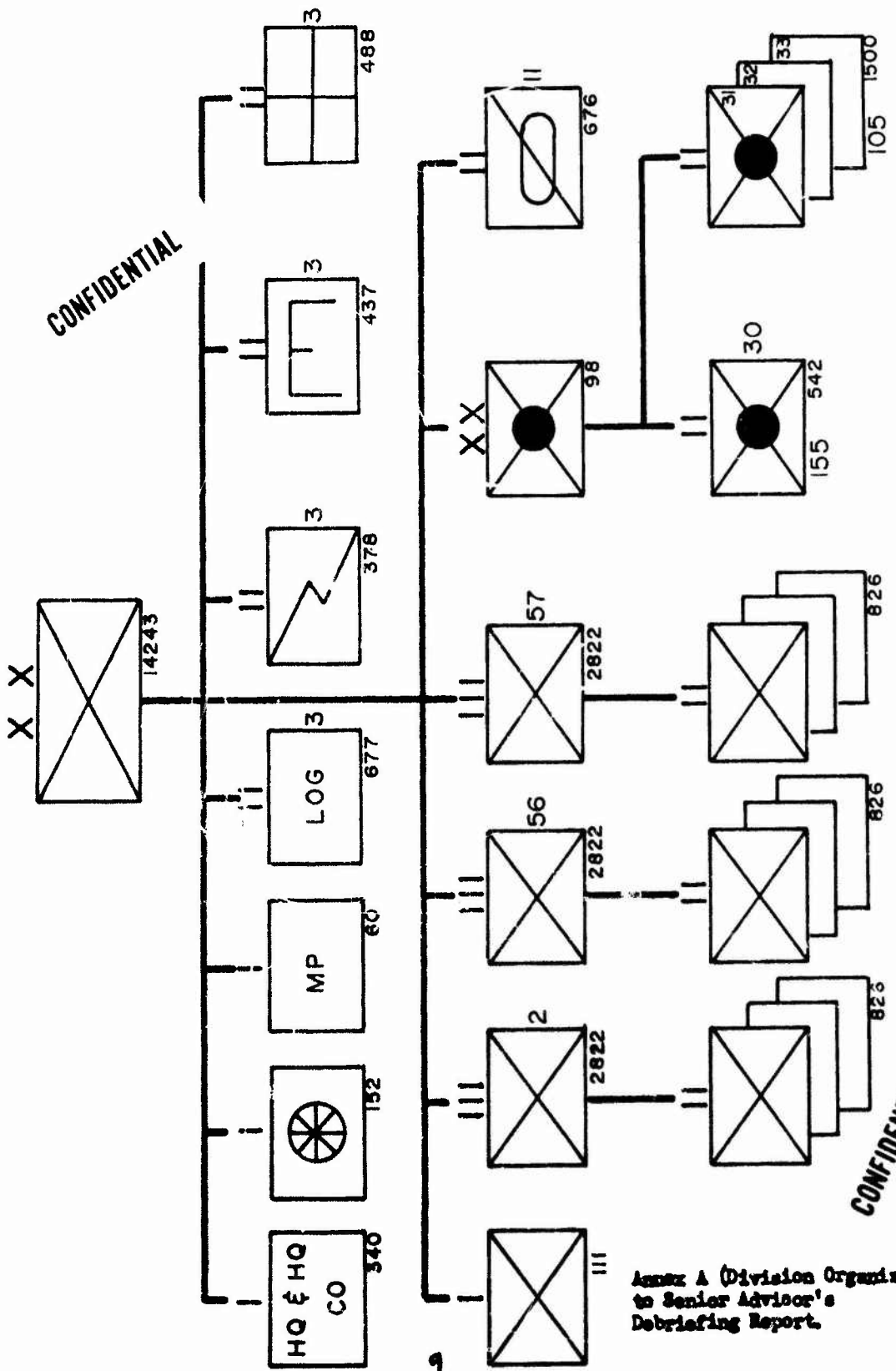

CONFIDENTIAL

CONFIDENTIAL

Annex A (Division Organisation) to Senior Advisor's Debriefing Report.

CONFIDENTIAL

PERSONNEL

1. General: There is little advisory effort required in the GI area. The previous GI, LTC Hien, was a highly qualified individual who served as the GI, First Special Brigade and on the GI Staff at I Corps. The present GI, LTC Nguyen Hoang Chuong, was recently assigned from the GI Section, 1st Division (ARVN). He is well aware of the problem areas and is striving to effect correction. He is being supported by the Commanding General who places strong command emphasis on the improvement of operational strengths of the combat maneuver battalions. AWOL's and desertions, combined with casualties, compose the major problem in the GI area. Lacking a high priority, replacements for the Division, especially the Infantry units, remain a serious problem hindering improvement of the Division's strength.

2. Strengths: At the end of May 1972, the 3d Division, following its retreat from Quang Tri, had an assigned strength of 10,618 of its authorized 14,243. Of the assigned strength, however, the Division could only account for 5,798 present for duty. With a concentrated effort, the Division gradually increased its strength to achieve a peak during September 1972, at which time, the assigned strength reached 84% and the present for duty strength reached 76%. During these months of gradual increase of strength, AWOL's and desertions continued to plague the Division. Many of the replacements provided for the Division were former military prisoners and the assignment of a tremendous number of this type of soldier was certainly a contributing factor to the high AWOL and desertion rate. During September, the Division had its highest assigned and present for duty strength achieved during CY 72. Assigned strength is currently at 84% of TOE and present for duty strength is 76%. The Division received 1,225 replacements during the month of September. Of these, only 36 were former prisoners. Currently, the only serious personnel shortages of the Division are in the Infantry Regiments; these are at 80% of authorized strength. The Division has recently received permission from the Joint General Staff (JGS) at Saigon, to allow prospective enlistees to volunteer for the 3d Division. This permission was granted for a three month period.

3. Quality

(1) Trainings: Recruitment input into the Division has been from the National Training Centers at Dong Da and Hoa Cam in Military Region I. The quality of training for the Division's replacements is considered to be satisfactory. In addition, the 3d Division conducts a one week familiarization course for replacements in order to better prepare them for the rigors of combat.

(2) Leadership

(a) Commanding General: Brigadier General Ninh is an excellent tactician and a professional soldier. Having taken command of the 3d Division (ARVN) on 9 June, during its reorganization after being mauled at Quang Tri,

ANNEX 3 (Personnel) to Senior Advisor's Debriefing Report

CONFIDENTIAL

he made a quick but thorough assessment of the weaknesses of his new command. He then began a wideranging program to revitalize his Division. Working energetically, he galvanized his staff and subordinate commanders. He placed greatest emphasis on the Division regaining it's capability to move, shoot, and communicate. He has concentrated on buoying morale and regaining individual self respect. Improvements were made across the board throughout the Division. He enjoys the respect of his subordinates because of his demonstrated ability, broad experience, and well deserved reputation for fairness. His impressive achievements, since assuming command of the Division, have represented a tour de force encompassing tactical acumen, solid managerial skill, inspired leadership, and great strength of purpose. He has every quality needed to become a very competent Corps Commander.

(b) Assistant Division Commander: Colonel Chung is a most capable soldier. He is an experienced combat leader whose background is broad and varied, and includes command at Regimental and Battalion levels. He has commanded the Division briefly on occasion. He maintains a firm, guiding hand on the Division Staff and requires high standards of performance. Visits are frequently conducted by Colonel Chung to subordinate elements in the field. Deep interest in the welfare of the men are reflected in his checking of quarters, mess facilities, and work areas. Colonel Chung readily grasps new ideas and welcomes and accepts advice that is innovative. Colonel Chung appears to be greatly respected by all ranks. His knowledge of tactical operations and administrative functions enable him to oversee the activities of subordinate commanders and lower level staffs. Relationships with advisory personnel are always warm and congenial. He is steady under pressure and remains completely calm regardless of the situation and circumstances.

(c) Chief of Staff: Lieutenant Colonel Bao performs his duties in a quiet unassuming manner, receiving guidance and instructions from the Commanding General and the Deputy Commanding Officer. LTC Bao is figuratively tied to his desk behind the mountain of paperwork received and originated by his subordinates on the staff. He does, however, make great efforts to visit units of the Division and has been able to do so with commendable frequency, as the improved experience of the staff makes these absences feasible. He is an avid inspector and demands high standards. He is an extremely thorough individual and demands that all staff actions be followed-up.

4. Personnel Management: Following the withdrawal from Quang Tri, the 3d Division's personnel administration was in a shambles. Individual records had been lost; this seriously effected the efficiency of pay and other personnel services actions. In addition to combat created problems, there were cases of corruption, as well as inefficiency, due to incompetent personnel performing duties in this area. The Commanding General, 3d Division, places strong command emphasis in this area. It was his belief that the elimination of corruption and the establishment of a smooth, efficient personnel management system was a necessary basic foundation upon which to build effective fighting units. He felt that this was the key to gaining increased support and loyalty from his troops. Due to the Commanding General's strong command emphasis, personnel management has shown marked improvement throughout the Division. Every case of corruption uncovered has been punished. Policies are clear and the interest of subordinate commanders in this area has been developed. A "good" evaluation is deserved by the 3d Division's personnel management system. There are additional improvements required, however, a viable system exists and emphasis continues to be given to this area.

59

CONFIDENTIAL

MONTHLY PERSONNEL STRENGTH STATUS

CONFIDENTIAL

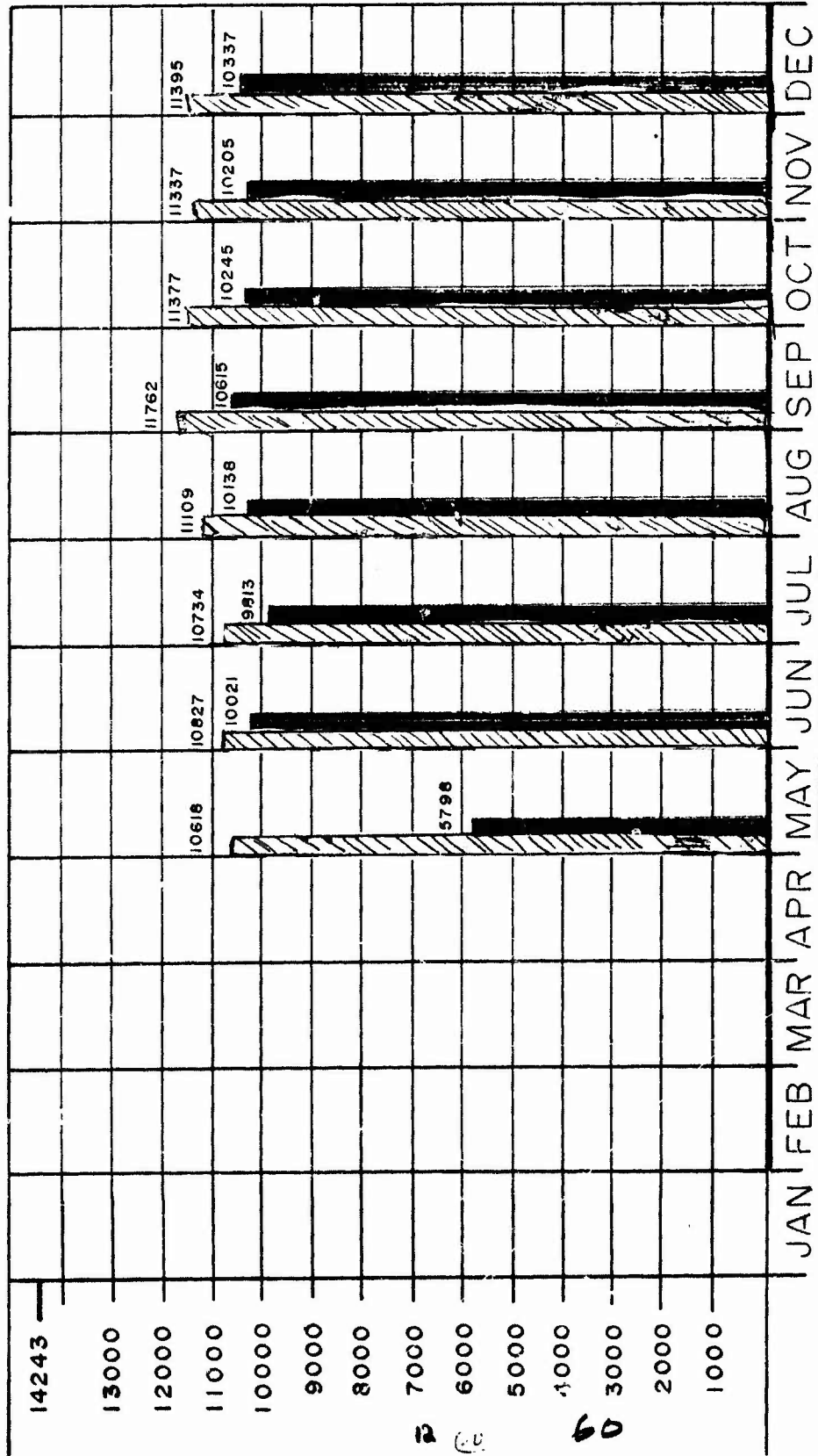

█ = ASG

█ = PFD

CONFIDENTIAL

ANNEX B (Personnel) to Senior Advisor's
 MONTHLY PERSONNEL STRENGTH STATUS) To ANNEX B (Personnel) to Senior Advisor's
 Briefing Report.

CONFIDENTIAL

DESERTION STATUS

	M O N T H											
	JAN	FEB	MAR	APR	MAY	JUN	JUL	AUG	SEP	OCT	NOV	DEC
700												
600												
500												
400												
300												
200												
100												
OFF	2	8	6	12	18	4	7	2	3	3	4	5
NCO	1	8	21	53	53	36	41	33	41	36	28	24
ENLISTEE	2	127	130	319	179	139	131	116	117	116	115	109
DRAFTEE	19	101	67	267	265	211	104	56	219	232	274	279
PRISONER		0	0	0	0	55	118	91	67	89	27	0
TOTAL	22	248	224	651	515	445	401	398	447	476	448	417

Appendix 2 (Monthly Desertion Status) to Annex B (Personnel) to Senior Advisor's Debriefing Report.

61

CONFIDENTIAL

CONFIDENTIAL **MONTHLY**
CASUALTY STATUS

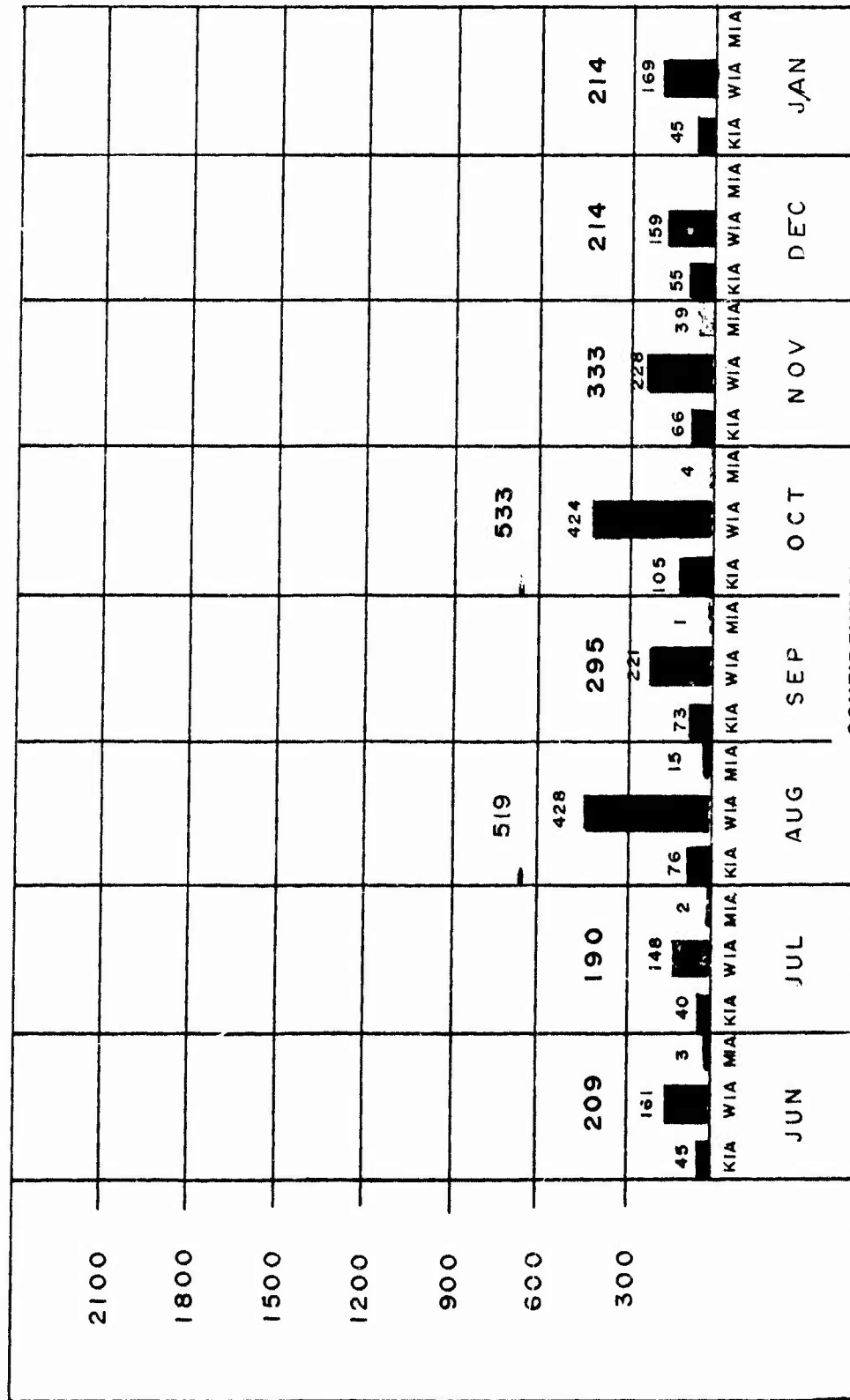

CONFIDENTIAL

Appendix 3 (Monthly Casualty Status) to Annex B (Personnel) to Senior Advisor's Debriefing Report.

CONFIDENTIAL

INTELLIGENCE

1. General: Toward the end of the 3d Division's involvement in the heavy fighting in Quang Tri Province, the G2 Section and its supporting military intelligence detachment in effect ceased operations, except for interrogation of prisoners and maintaining sketchy records of the battle. Each man seemed convinced of the futility of the Division's efforts and most awaited the resolution of uncontrollable events with fatalistic resignation. As a direct result, G2 morale was at an extremely low ebb. Very little was accomplished either operationally or in the reorganizational effort, by the G2 Section at the relocated Division Headquarters in Phu Bai. Since assuming operational responsibility for portions of Quang Nam Province, the attitude of the G2 Section has improved markedly, and the reorganization task has been undertaken with vigor and a growing sense of confidence. The G2, Major Quy, approached the reorganization of his section with a firm idea of how he wanted to operate and what he wanted to accomplish. It should be noted at this point that Maj Quy is a very accomplished G2. As of this date, the entire G2 Section is functioning efficiently and as integral part of the Division staff.

2. Organization and Functions: The G2 Section has settled into its new organizational mold after a period of transition and re-establishment of normal functions. An awareness of the value of integrating all available information has developed, particularly with regard to sensors, radar, IOS, and URS data, all of which provide immediately exploitable information concerning enemy movement and locations. Personnel now have the specific assignment of correlating such information.

3. Capabilities:

a. The G2 Section currently has at its disposal most of the means required to produce intelligence for the Division. Information collected by intelligence and intelligence related agencies are available to the G2. Aerial support, to include VR, APD, SLAR, and photo missions can be requested from higher headquarters. Because of limited assets and competing priorities elsewhere, however, such missions requested by the Division cannot always be flown. With regard to VR efforts, most of the VR information within the Division area of interest is derived from US Air Cavalry missions. VNAF fixed wing capabilities are limited and it is doubtful that they will approach the effectiveness of the US Air Cavalry Teams. When the US Air Cavalry units finally depart, they will leave a gap in the reconnaissance effort and it is doubtful that Vietnamese assets will be able to fill the resultant void.

b. The G2 publishes an Intelligence summary which is sent to subordinate S2's, with information copies to adjacent and higher headquarters. Additionally the G2 disseminates other information, as available, in separate messages. These messages deal with enemy locations, intentions, and activities. The G2 also compiles estimates of the enemy situation, based on current and updated information and are transmitted to subordinate, adjacent, and higher headquarters.

63

ANNEX C. (Intelligence) to Senior Advisor's Debriefing Report.

15

CONFIDENTIAL

CONFIDENTIAL

The momentum of his dissemination effort is definitely adequate.

4. Evaluation of Intelligence Effort:

a. Significant Limiting Factor:

(1) The junior officers assigned to the G2 Section require constant prodding and supervision. When instructions are issued, they are seldom followed up to determine or to assess the quality of the work.

(2) G2 Air personnel are intelligent and capable. However, at the same time they are unimaginative and unassertive, generating mission request or studies of available data only when specifically directed by the G2.

(3) Of particular concern is the lack of an orientation toward the "Big Picture", (Keeping the subordinate S2's informed on events in areas beyond their operational reach).

b. Coordination Between Agencies: On 24 July 1972, the 3rd Division held a conference for intelligence agencies in Quang Nam Province. Attendees included the Commanding General, 3d Division, 3d Division G2, Quang Nam Sector S2, and representatives from Danang Special Sector, the 2d, 56th, and 57th Regiments, the Quang Nam Phung Hoang Program, and the National Police. Based on an assessment of the current situation, Essential Elements of Information (EEI) were developed and disseminated. The conference represented the first attempt at coordination of the overall intelligence effort in Quang Nam Province and in fact, was the first such conference held by the 3d Division since its activation. Greater coordination with other intelligence agencies has been a major objective of the advisory effort at the 3d Division for more than 6 months and this conference provided the basis for regularizing the coordination effort in Quang Nam. The distribution of EEI also represented an advancement in the coordination effort, as well as in the G2 dissemination effort. Until 24 July 1972, no EEI had ever been developed and distributed in this manner by the Division G2. This conference was only the first step in a series of other means, presently being utilized, in coordinating with other agencies as is exemplified by the conduct of liaison visits, exchange of intelligence, updating of EEI, and conduct of conferences on a smaller scale. All the various means of effecting greater coordination are currently being utilized. Of extreme importance is the emphasis that the Commanding General, 3d Division, places on the conduct of coordination and cooperation, especially in the area of intelligence.

CONFIDENTIAL

CONFIDENTIAL

DIVISION TRAINING

1. General: The 3d Infantry Division Training Center (newly activated) is located at Freedom Hill (Khanh Son). It conducts a one week familiarization course for all Division replacements. To date, 2,876 replacements have completed this training. This program is conducted by selected cadre of the Division with emphasis being placed on weapons and tactics. This limited training capability is attributed to the shortage of qualified cadre with which to conduct other types of training. However, basic and advanced infantry training began late in January 1973. It should be noted, however, that in view of the scope and nature of combat operations, training has been conducted and progressed in a satisfactory manner. Internal unit training is not currently being conducted due to the scale of operations presently in progress.

2. Specialized Training:

(1) During 1972, the Division conducted a vigorous re-training program for its infantry battalions and reconnaissance companies. This instruction was presented by the MACV Special Forces Mobile Training Team during the period May through August 1972, culminating in eight battalions and four reconnaissance companies completing a two week training program. The program of instruction for the units included weapons, tactics, and reconnaissance techniques. The following units have completed the Division training program:

<u>UNIT</u>		<u>DATES</u>	<u>LOCATION</u>
2d Battalion, 56th Regiment	(837 personnel)	14-25 May	Phu Bai
3d Battalion, 2d Regiment	(652 personnel)	21 May-3 Jun	Phu Bai
2d Battalion, 57th Regiment	(638 personnel)	1-14 Jun	Phu Bai
2d Battalion, 2d Regiment	(556 personnel)	7-18 Jun	Phu Bai
3d Battalion, 57th Regiment	(338 personnel)	1-14 Jul	Phu Bai
1st Battalion, 2d Regiment	(350 personnel)	7-21 Jul	Phu Bai
3d Battalion, 56th Regiment	(636 personnel)	23 Jul-5 Aug	Phu Bai
Recon Company, 56th Regiment	(97 personnel)	6-29 May	Phu Bai
Recon Company, 3d Division	(103 personnel)	21 May-17 Jun	Phu Bai
Recon Company, 2d Regiment	(94 personnel)	21 Jul-18 Aug	Hoa Cam
Recon Company, 57th Regiment	(120 personnel)	21 Jul-18 Aug	Hoa Cam

The remaining battalions of the Division are scheduled to undergo training as follows:

1st Battalion, 56th Regiment	April 1973	Hoa Cam
3d Battalion, 57th Regiment	April 1973	Hoa Cam

(2) During 1972, 608 officers and men of the Division graduated from specialized or advanced training courses throughout the country. On 15 January 1973, sixty-nine personnel of the Division began a one week refresher training program conducted for platoon and squad leaders. As soon as operational commitments will permit, the Division plans to conduct a minimum of twenty-four hours of internal unit training per week.

ANNEX D. (Division Training) to Senior Advisor's Debriefing Report.

CONFIDENTIAL

65

CONFIDENTIAL

CUMULATIVE RESULTS OF OPERATION TIEN-PHUOC DISTRICT TOWN

1. Friendly:	KIA - 18 WIA - 78
2. Enemy:	KIA - 233 POW - 3
2. Weapons:	Crew Served - 24 Individual - 97
3. Other;	Tanks - 2 PT 76 Radios - 10 Telephones - 7

ANNEX E. (Cumulative Results of Operation Tien-Phuoc District Town) To Senior Advisor's Debriefing Report.

CONFIDENTIAL

66

CONFIDENTIAL

CUMULATIVE RESULTS OF OPERATION QUE-SON DISTRICT TOWN

1. Friendly: KIA - 27
 WIA - 91
 MIA - 15

2. Enemy: KIA - 203
 POW - 4

3. Weapons: Crew Served - 8
 Individul - 46

4. Other: Ammunition - 115 Rds, 82mm Mortar
 62 Rds, 61mm Mortar

ANNEX F. (Cumulative Results of Operation Que-Son District Town) to Senior Advisor's Debriefing Report.

CONFIDENTIAL

67

CONFIDENTIAL

CUMULATIVE RESULTS OF OPERATIONS QUANG TRUNG 81 AND 81/A

1. Friendly:	KIA - 119
	WIA - 583
	MIA - 2
2. Enemy:	Rallier - 12
	KIA - 1,495
	POW - 30
3. Weapons:	Crew Served - 102
	Individual - 290

ANNEX G. (Cumulative Results of operations Quang Trung 81 and 81/A) to Senior Advisor's Debriefing Report.

CONFIDENTIAL

68

CONFIDENTIAL

ANNEX H. (Logistics and Communications) to Senior Advisor's Debriefing Report.

LOGISTICS AND COMMUNICATIONS

1. Logistics:

a. General:

(1) Early in June, LTC Mai Xuan Tung, assumed the duties of Division 44 and immediately began reorganizing and streamlining the logistical activities of the Division. He initiated quarterly logistical conferences to disseminate information and to discuss logistical problems. To date, these conferences have been extremely successful, as all concerned are aware of logistical problems and the corrective actions required. Further, LTC Tung, instituted a uniform Material Readiness Reporting System which has enabled the Division Commander and staff to keep abreast of the Division's material status.

(2) In June, plans were formulated for the formation of the Division Logistics Battalion and the Division Engineer Battalion. In July, JCS approval was received to begin the formation of those two units on 1 August, and they were fully operational on 1 December 1972. Personnel and equipment for the Logistics Battalion was provided from 3d Division and IALC resources. For the Engineer Battalion, personnel were provided from ARVN wide resources and equipment was requisitioned through ARVN supply sources. These two important units are now operational.

b. Supply:

(1) As of 15 January 1973, the Division had 72% of its critical ordnance equipment, 57% of its critical signal equipment, and 56% of its critical equipment on hand. The most critical shortages exist in the following areas: wheeled vehicles, power generating equipment, dump trucks, vehicular mounted AM radios, radio teletype equipment, multichannel radio relay equipment and telephone sets. Although the Division has been successful in combat during the past 4 months, the shortages of equipment severely hampers tactical flexibility.

(2) Initially, the Division was extremely slow in reporting combat losses. However, with continued advisory emphasis on the necessity for timely reports of combat losses, the replacement of material has improved to some degree. Problems still exist, though, within the overall ARVN logistical system in reacting to critical requirements. This is especially true in repair parts supply. Continued emphasis has been placed on timely submission of repair part requisitions and the maintenance of adequate PII's and ASI's.

c. Transportation: Lack of adequate ground transportation assets has hampered speedy movement of personnel, equipment, and supplies during combat operations. Further, lack of adequate air support has hindered resupply operations in remote areas and timely MEDEVACS of wounded personnel. In some cases delays of up to 3 or 4 hours have been experienced in receiving aircraft for MEDEVAC missions.

ANNEX H (Logistics and Communications) to Senior Advisor's Debriefing Report

CONFIDENTIAL, 21 69

CONFIDENTIAL

d. Maintenance:

(1) With the establishment of the 3d Division Logistical Battalion, many of the Division's maintenance problems were overcome. There is, however, still no really effective organizational maintenance program throughout the Division.

(2) Excessive downtime rates continue for 2 1/2 ton trucks and artillery pieces. Part of this problem is attributed to the lack of sufficient tools at the organizational level. However, there is little emphasis on such basic items as keeping equipment clean and checking proper oil and fuel levels of mechanical equipment.

2. Communications:

a. Initially, acute shortages of communications equipment (35% on-hand as of June 1972) severely handicapped the Division Commander's ability to exercise adequate command and control over Divisional elements. However, by 15 January 1973, sufficient communications equipment was on hand to enable the Division and its subordinate elements to establish essential communications, with FM voice, SSB voice, and AM CW communications from Division Headquarters and Forward CP to each of the Regiments. Additionally, the Division is capable of establishing multi-channel radio relay systems from the Division Base or Forward CP to each of the Regiments and between the Division Base and Forward CP.

b. Communications personnel throughout the Division appear adequately trained. They perform well and establish and maintain required communications effectively and efficiently.

CONFIDENTIAL 22

70

CONFIDENTIAL

COMBAT SUPPORT

1. Artillery: Artillery support continues to be extremely effective. The organic battalions respond to requirements energetically and enthusiastically. The Division Artillery staff functions well as a control headquarters. In the past the Division Artillery Commander did not serve as the Division Fire Support Coordinator. This was due to the employment of the various Regiments throughout the area of operations with Artillery units dispersed in direct support of each Regiment where each Fire Support Base could be mutually supporting from at least one other Fire Support Base. But now as the Division is employed as an entity in operation Quang Trung 81/A, he is serving as the Division Fire Support Coordinator. Artillery maintenance is a continuous problem; however, attempts are being made to rectify this situation. A need exists for stronger control from Division Artillery to the various Artillery Battalions. Fires on suspected enemy locations, radar observations, and sensor activations are oftentimes excessive; controls should be placed on the amount of ammunition to be expended on these types of targets. ASR's have been established and improvement has been demonstrated in this area.
2. Tactical Air: The tactical air support provided by VNAF has become increasingly effective, however, US tactical air in a close support role continues to play a dominant role in operations. A problem still exists in the area of VNAF FAC coverage. A greater number of VNAF FAC's are required to adequately complete their assigned VR and FAC missions. At the time of this report, VNAF FAC's response to an ALO FRAG order for a specific mission is slow. Once they are on station, however, they process effectively all immediate tactical air requests to I DASC.
3. Aviation: US Army Aviation support, especially that provided by the 11th CAG and D Troop, 17th Cav, was outstanding. As US aviation assets diminish, Advisors are gradually restricting the use of US assets in favor of VNAF or use of ground transportation. It should be noted, however, that as US assets continue to be withdrawn, a gap will exist in the Air Cavalry reconnaissance support, unless support is provided from VNAF sources.
4. Engineers: Engineer support for the 3d Division combat elements is considered good. All Engineer elements demonstrate an exceptional level of proficiency. In addition to the usual firebase construction and improvements, one major engineering project undertaken during operations in the Que Son Valley has been the construction of roads, bridges, and repairs to existing roadways in order to improve and maintain the Division MSR. One problem area that continually plagues engineering elements, as it does other units, is maintenance of vehicles. Improvement is certainly required in this area.
5. Other Operational Assets: The 3d Division sensor program has expanded significantly with the assumption of responsibility for operations in Quang Nam Province. Especially noteworthy is the efficiency in control, utilization, and technical competence of operators, as well as the proper employment of assets. Now, the Division has full responsibility for the conduct of sensor operations within its area of operations, to include planning, implants, resupply, monitoring, and coordination with units for appropriate tactical action.

ANNEX I (Combat Support) to Senior Advisor's Debriefing Report.

CONFIDENTIAL

CONFIDENTIAL

REGIMENTAL ASSESSMENTS

1. 2d Regiment:

a. Leadership: The Commanding Officer, LTC Hoanh, has demonstrated only fair leadership in directing elements of the Regiment. He is well grounded in infantry tactics and utilizes fair judgment in employing these. He willingly accepts full responsibility for his own actions and those of his subordinates. The one leadership attribute that he completely lacks is that of aggressiveness. The 1st Battalion Commander, Major Nam, is a capable officer and practices the fundamentals of good leadership. He exhibits excellent moral and character of strength, appears to have the courage of his convictions, and displays calmness under pressure. The 2d Battalion Commander, Major Thao, has only recently assumed command of the unit (20 Jan 72). He seems to be a very capable officer and demonstrates the degree of alertness, intellectual honesty and courage required to command a unit in combat. The 3d Battalion Commander, Major Tan, is considered to be the best battalion commander in the Regiment because of his past successful action. He is calm under pressure and exhibits the leadership attributes of enthusiasm and initiative.

b. Personnel Management: Personnel management within the Regiment is good. Considerable command emphasis is placed on accurate personnel accountability.

c. Capability: Both the 1st and 3d Battalions are capable of performing well in a combat situation, as has been amply demonstrated. The 2d Battalion has performed well against VC forces, however, when NVA forces are encountered, the Battalion folds at the first evidence of medium resistance.

d. Evaluations: The Regiment is fully capable of performing any assigned mission. As far as the maneuver battalions are concerned, the 3d Battalion is the best battalion of the Regiment; the 1st Battalion is second; and the 2d Battalion is the weakest. However, under the leadership of Major Thao, it is anticipated that improvement will be forthcoming.

e. Adequacy: The Regiment has approximately 70% of its authorized TO&E equipment. From all indications, the personnel of the unit are well trained to perform assigned missions with the equipment currently on hand.

f. Requirements: Junior officers and NCO's assigned to the Regiment seem to lack the quality deemed necessary for individuals in their positions. Perhaps, the NCO School established by the Division will help to alleviate a portion of this problem, however, emphasis should also be placed on the development of junior officers.

2. 56th Regiment:

a. Leadership: The Commanding Officer, LTC Vinh Duc, is intelligent, aggressive, and dependable. He has commanded the Regiment since 4 April 1972

ANNEX J. (Regimental Assessments) to Senior Advisors Debriefing Report.

CONFIDENTIAL

24

72

CONFIDENTIAL

With considerable success while rebuilding the unit from an ineffective status. He is only 30 years old, but has gained vast experience by serving 10 years (total service) in various leadership positions. He should continue to perform well in his present position and he exceeds most in potential for higher command positions. The 1st Battalion Commander, Major Ngo Viet Tinh, assumed command of one of the best battalions in the Regiment in October 1972. In a short period of time, he has demonstrated that he is one of the best commanders in the Division. Major Tinh has accomplished the rare feat of leading his unit successfully in difficult combat situations while attaining extremely low AMOL and desertion rates. The 2d Battalion Commander, Major Vo Van Dat, has been in command since and prior to the enemy DMZ invasion in March 1972. After the Regiment's defeat at the DMZ, he was the lone commander to rally his battalion and lead it from enemy held territory. His battalion has been a consistent high performer and accomplished one of the Division's most noted successes involving the capture of Tien Phuoc in October 1972. The 3d Battalion Commander, Major Nguyen Van Chinh, has been in command since December 1972 and has had little opportunity to display his abilities. The 3d Battalion is rated as one of the poorest in the Division and Major Chinh was selected to command this unit due to his past performance as an able commander.

b. Personnel Management: Personnel management has improved from unsatisfactory, following disorganization of all Division units in May 1972, at Quang Tri, to satisfactory at the present time. The Regimental S1 and Finance Officer are competent, and with considerable command guidance from the Division Commanding General and Regimental Commander, their performance has improved tremendously. While some actions are difficult to accomplish concurrent with continual combat operations, improvement in all personnel functions have been noted.

c. Capability: The 1st and 2d Battalions are capable of performing all assigned missions. The 3d Battalion has not performed adequately since September 1972, however, with strong leadership, the battalion should perform satisfactorily in the future. The Regimental Reconnaissance Company has not adequately performed most missions and will not do so until a competent commander is assigned.

d. Evaluations: The 1st and 2d Battalions perform well in all types of missions. The 3d Battalion has functioned satisfactorily in security and rocket belt missions, but has not produced the desired results in the conduct of offensive operations. Current action being taken to bolster leadership in the 3d Battalion should eliminate this problem area.

e. Adequacy: All units possess the capability and experience to perform assigned missions. Most necessary supplies and equipment have been provided to enable accomplishment of ground support missions.

f. Requirements: Junior officer and NCO's of high quality are required in order to insure consistently high performance. In some cases, however Battalion and Regiment staff officers lack necessary experience. The unit has recovered from most essential equipment losses in Quang Tri, however, there are numerous items that remain unreplaced and are required to enable full, all around, TOE mission performance.

CONFIDENTIAL

3. 57th Regiment:

a. Leadership: The current Commanding Officer, LTC Pham The Vinh is an extremely intelligent, competent, and experienced commander. He assumed command of the Regiment in January 1973, and even though he has been with the Regiment for a short period of time, he exhibits a sincere concern for the welfare of his troops and displays a thorough knowledge of all aspects of command. He practices the fundamentals of good leadership and requires proficiency in the basic skills of his individual soldiers. The 1st Battalion Commander, Major An, is a young aggressive and eager commander. He tends to be impulsive on occasion; however, he is a capable leader. It should be noted, however, that at times, he tends to be over cautious which may be attributed to humanitarian feelings and the desire to sustain the least amount of casualties as possible. The 2d Battalion Commander, Major Chau, is a very capable officer and consistently displays the leadership abilities of knowledge, aggressiveness, and imagination. His unit consistently displays discipline, high morale, esprit de corps, and proficiency. The 3d Battalion Commander, Major Pham Huu Ba, is a relatively new commander. He assumed command of the battalion after its defeat by enemy forces in the attack on Que Son. He exhibits good leadership attributes and has had considerable success in the rebuilding and training of the battalion.

b. Personnel Management: Personnel management has improved tremendously from unsatisfactory, following the Quang Tri defeat, to good. However, continued improvement is required. The Regiment has sound personnel management procedures and a liberal leave policy consistent with operational demands. The Regimental Commander has taken positive steps to reduce the units AWOL and desertion rate. These actions are exemplified by the fact that since assuming command, the AWOL and desertion rate have been considerably reduced.

c. Capability: Each of the three battalions are capable of performing their assigned missions. Logistical support provided by the Regiment has been good and temporary shortages have not significantly effected the battalions capability to shoot, move, and communicate. Command and control of subordinate units is considered adequate.

d. Evaluation: The Regiment is capable of performing all of its assigned missions. Of the maneuver battalions, the 2d Battalion is the best battalion in the Regiment; the 1st Battalion is second; and the 3d Battalion is the weakest. However, under the able leadership of Major Ba, the 3d Battalion will improve considerably.

e. Adequacy: All units are adequately trained and equipped to perform their TO&E missions.

f. Requirements: The quality of junior officers and NCO's leaves a lot to be desired and, in a few cases, Regimental and Battalion staff officers are lacking in the necessary experience to accomplish assigned tasks. Emphasis should be placed on the development of junior officers and NCO's, and placement of individuals with sufficient experience to staff positions.

CONFIDENTIAL

CONFIDENTIAL

ORGANIZATION FOR DEFENSE OF DANANG VITAL AREA

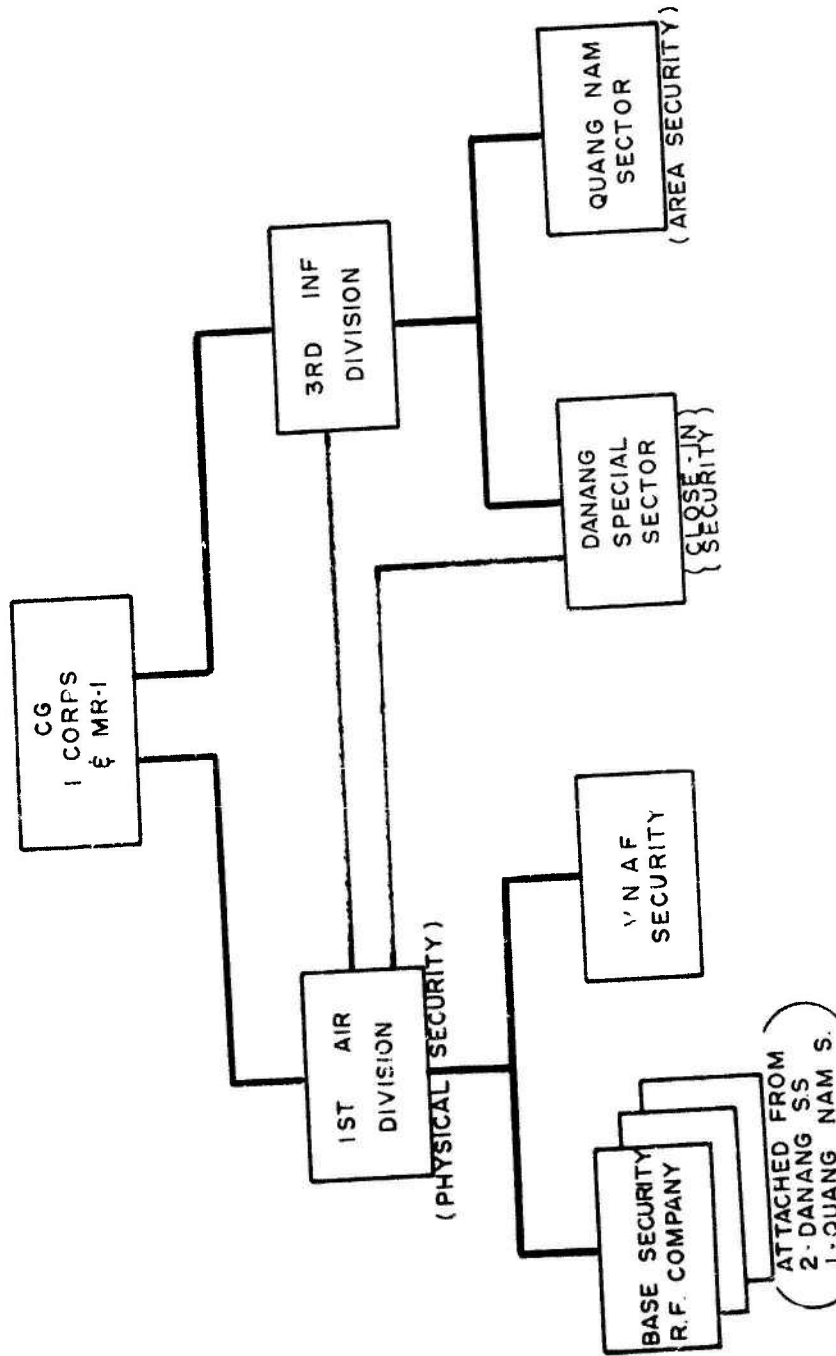

— COMMAND
 — OPCON
 — COORDINATION

Annex K. (Organization for Defense of Da Nang Vital Area) to Senior Advisor's Debriefing Report.

CONFIDENTIAL

75

MACV ADVISORY TEAM 155

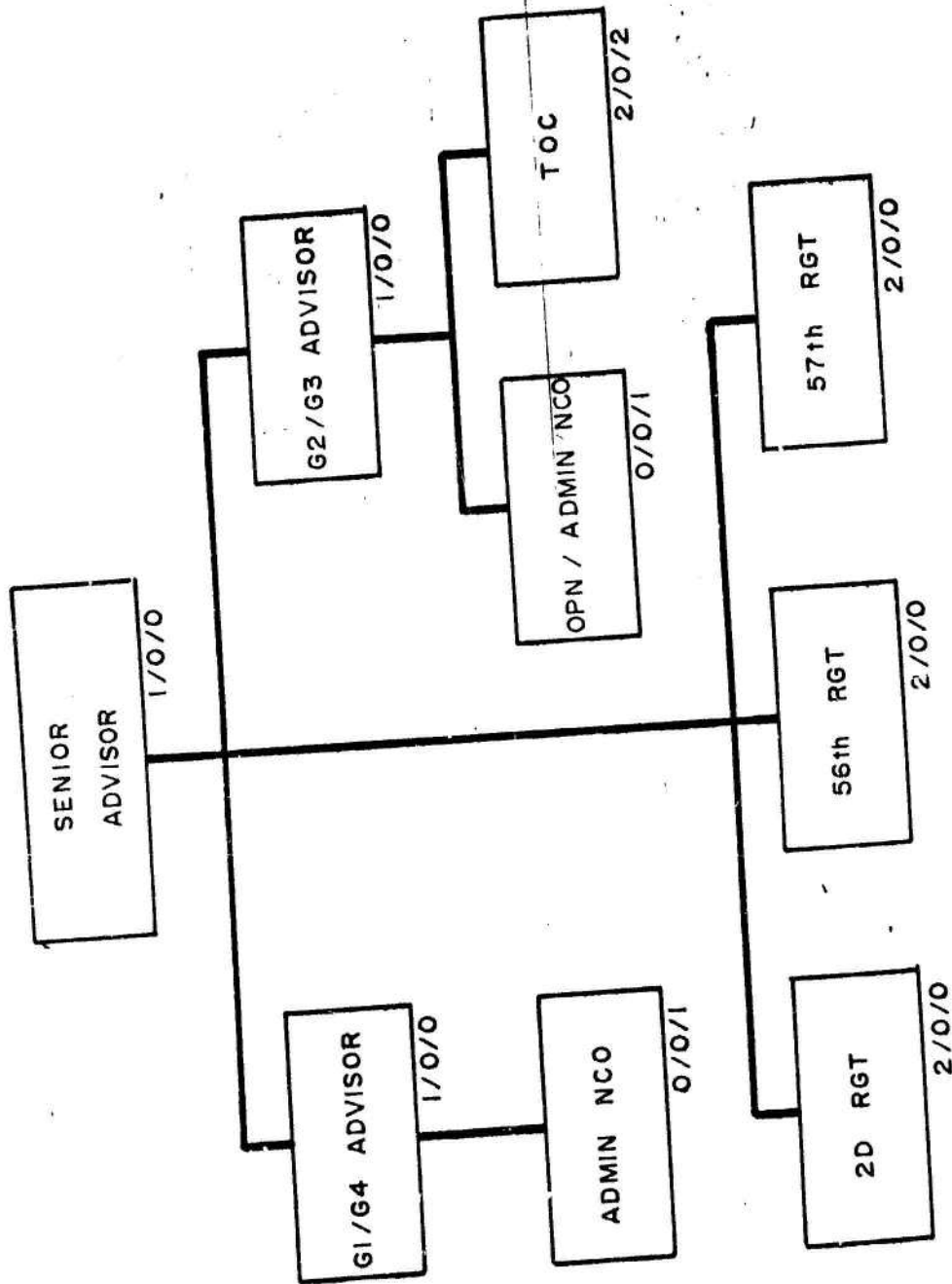

CONFIDENTIAL

Annex L (Advisory Team Organization) to Seniors Advisor Debriefing Report.

CONFIDENTIAL

28

76

CONFIDENTIAL

HEADQUARTERS
MACV Advisory Team 155
3d Infantry Division (ARVN)
APO San Francisco 96349

MACFR-3D-SA

13 November 1972

SUBJECT: Implications of the Reduction in Strength of Advisory
Team 155.

Commander
First Regional Assistance Command
APO 96349

1. The reduction of this Advisory Team by two-thirds will have a significant impact on its capability to provide liaison with higher headquarters and simultaneously to provide advice to the Commander and Staff of the 3d Division. A test under actual operational conditions was conducted between 18 and 22 October 1972, to determine the effect of the projected reduction. During that period, the Team operated two TOC's; one with the Division Light CP at FSB BALDY and the other at the Division Rear at Freedom Hill. The test revealed that this team, without augmentation, cannot operate two TOC's and still perform adequately its other assigned functions. In the 96 hour course of the test, the two TOC's were operated successfully, but there was no spare time in which to provide advice and assistance to the Division Staff. This suggests that anything beyond the Liaison function becomes all but impossible when the 15-man team is operating two Division level TOC's and continues to maintain three regimental level advisory cells.
2. Other findings were revealed by the test. These include the fact that reasonably efficient operation of a division level advisor TOC can only be insured when no less than two personnel are on duty at all times. These individuals are required to perform the essential liaison functions (reporting information; assisting in securing clearances for U.S. TACAIR, "Stinger", "Nighthawk" and gunships; coordinating ARC Light requests; etc). Thus, round the clock operations require that four of the nine personnel available at Division level be employed exclusively in one TOC. When viewed in isolation, this is an acceptable situation. Unfortunately, however, the 3d Division frequently finds it expedient to operate a forward tactical CP manned by the senior members of the General Staff. To maintain advisory effectiveness and to perform required liaison at the location of the Division's heaviest commitment, this requires that the Advisory Team establish a forward element to support this forward CP. TOC personnel must accompany the Division Command Group. This will have

Annex M (Letter to CG FRAC, Subject Strength Reduction) to Senior Advisor's
Debriefing Report.

99

CONFIDENTIAL

77

CONFIDENTIAL

the effect of leaving no one to oversee coordination of the US contribution to the defense of the DaNang Vital Area. Unlike the past when sufficient strength was available, it will not be possible to maintain advisory personnel in DaNang to coordinate US and ARVN Rocket Belt activities and to support the Division Main CP. The two man regimental advisory team located at Hill 55 might perform this task as an extremely short-term stopgap. Seventy-two hours would be the maximum time that the regimental team could perform effectively. If, however, all of the Division's regiments are employed operationally at some remove from the City, coordination for defense of the DaNang area must be assumed by some other headquarters.

3. In summary: With some strain and difficulty, Team 155 can accomplish all assigned tasks while operating one Advisory TOC. If CG, 3d ARVN Division, decides to move his Command Group to a forward CP, Team 155 will deploy forward also. In this manner, both the mission of advising the Commander and Staff of the 3d Division and of providing liaison with and coordination for higher headquarters can be accomplished. If the team is required to operate two TOC's, one or the other of these important functions will be slighted.

4. Recommendation: That Commander, FRAC direct that a system be established whereby responsibility for coordination of US tactical activity in the DaNang Rocket Belt, and clearance of fires associated therewith, be passed, when necessary, from Advisory Team 155 to Quang Nam Sector advisory personnel. Alternatively, that the role be assumed by Headquarters FRAC.

c.c.

3A, Quang Nam Sector

C. B. McCoid
C. B. McCOID
Colonel, Infantry
Senior Advisor

CONFIDENTIAL

CONFIDENTIAL

MACFR-OF (27 Jan 73) 1st Ind
SUBJECT: Senior Officer Debriefing Report

Headquarters, First Regional Assistance Command, APO 96349, 9 February 1973

THRU: Commander, US Military Assistance Command, Vietnam, ATTN: FACDO-4,
APO 96222

TO: Assistant Chief of Staff for Force Development, ATTN: FOR OT UT,
Department of the Army, Washington, D.C. 20310

The Debriefing Report prepared by COL C.B. McCoid, Senior Advisor to the
3rd Infantry Division (ARVN), has been reviewed by this headquarters and
no additional comment is necessary.

FOR THE COMMANDER:

MICHAEL A. CARLINI
CPT, AS
Adjutant General

CONFIDENTIAL

79 80B

HEADQUARTERS
THIRD REGIONAL ASSISTANCE COMMAND
APO SAN FRANCISCO 96266

MACTR-CS

10 January 1973

SUBJECT: Senior Officer Debriefing Report of COL W. F. Ulmer, Jr.,
Senior Advisor to 5th ARVN Infantry Division (RCS CSFOR-
74)

THRU: Commander
Third Regional Assistance Command
APO San Francisco 96266

Commander
US Military Assistance Command, Vietnam
ATTN: MACDO-34
APO San Francisco 96222

Assistant Chief of Staff for Force Development
ATTN: FOR OT UT
Department of the Army
Washington, D. C. 20310

1. This report is submitted as required by AR 525-14. It contains observations and comments derived from my assignment as Senior Advisor to the 5th ARVN Infantry Division from 8 May - 21 December 1972. The report is in four parts: (a) overview of 5th ARVN Division activities; (b) assessment of 5th ARVN Division operations; (c) advisory philosophy and methods; and (d) considerations for future planning. I assume that the readers of this paper are generally familiar with the advisory effort in Vietnam, the strategic and tactical environment in Vietnam in 1972, ARVN organization, and related pertinent background data.

2. Overview of 5th ARVN Division Activities:

a. From May through mid-July the 5th ARVN Division continued its important role facing the major NVA attack into Binh Long Province. At An Loc the enemy massed firepower, used antiaircraft weapons in significant numbers, employed several dozen tanks, and ultimately expended the bulk of three divisions in an unsuccessful attempt to overcome the stubborn ARVN defense. Massive US air support was a key

DAMO-ODJ
73B006
Inclosure 3

MACTR-CS

10 January 1973

SUBJECT: Senior Officer Debriefing Report of COL W. F. ULMER, JR.,
Senior Advisor to 5th ARVN Infantry Division (RCS CSFOR-
74)

factor in this campaign. The division lost several hundred killed and over 3,000 wounded or missing. Major equipment losses included 26 howitzers, 140 trucks, and more than 50 tracked vehicles. (Details of this battle, which approached what we term mid-intensity conventional warfare, can be found in the MACV after action report on the Binh Long Campaign.)

b. July through September saw the division performing security operations in Binh Duong, Hau Nghia, and lower Binh Long Provinces. Re-equipping and retraining proceeded on schedule, with particular emphasis on the 9th Regiment and the 1st Armd Cav Squadron, those units having been decimated in the Loch Ninh battle in April.

c. In October, enemy pressure increased as peace talks were revitalized, and division activities included several important road and hamlet clearing operations from the division base camp at Lai Khe south along highway 13 to the Bien Hoa provincial border. In November and December units were continuously repositioned in an attempt to provide security to routes and villages and to locate an elusive enemy whose capabilities for sustained offensive operations had been weakened severely.

3. Assessment of 5th ARVN Division Operations.

a. General Posture. At this writing the 5th ARVN Division seems to enjoy a relatively good reputation within Military Region III. As a unit the division is more confident and effective than it was several months ago, and possibly is better than it ever has been. This improved capability resulted from recent extended combat experience and the arrival of several senior officer replacements who are more competent and aggressive than their predecessors. The division can operate without a US advisory team in attendance, although the small US team remaining still enhances effectiveness to some degree. The division would be in a significantly better state of combat readiness had it not suffered severe battle losses among experienced NCO's and company grade officers.

MACTR-CS

10 January 1973

SUBJECT: Senior Officer Debriefing Report of COL W. F. ULMER, JR.,
Senior Advisor to 5th ARVN Infantry Division (RCS CSFOR-
74)

The present division commander is simply outstanding. He and the likes of him will save the country - if the system can regularly identify and promote such competent and dedicated professionals.

b. Dependence on Non-Divisional Resources. The TOE provides a relatively self-sustaining and balanced divisional structure. VNAF fixed wing close air support is excellent when available. VNAF helicopter support is erratic, sometimes excellent but more often unsatisfactory. The VNAF choppers operate as an independent force usually impervious to the pleas or threats of ARVN commanders. Placing helicopter units in VNAF instead of within ARVN was a basic mistake. Not providing RVNAF with some form of air cavalry unit leaves a big gap in ARVN reconnaissance capability.

c. Effectiveness of the Division Staff. ARVN staffs are usually intimidated by the commander, respond to his initiatives but not to their own, and carry a hefty share of deadwood. The 5th ARVN Division staff is no exception; however, great strides have been made. The staff has practiced and improved its functioning over the past months of heavy combat. The present division commander exploits staff capability to a greater degree than did the commander he replaced in September 1972. The staff now gets out to look around, but would resort to isolating itself with maps and radios if given the opportunity. Staff supervision has improved but requires continuous command prodding. Coordination among staff section is fair and improving. G2 now works closely enough to FSCC and G3 to permit prompt reaction to intelligence although the true initiative to act still comes from the commander himself. G2 does not give enough attention to directing the collection effort. The G1 was until recently merely an undermanned briefing section but now with an upgraded complement and the daily interest of the commander that section stimulates some interest in the gamut of personnel activities. The G4 section learned a lot in the Binh Long campaign, but is not quite up to influencing tactical decisions before the fact. The psywar section has been given a new lease on life and gets daily attention, although they remain behind the power curve and continue being a day late and a dollar

MACTR-CS

10 January 1973

SUBJECT: Senior Officer Debriefing Report of COL W. F. ULMER, Jr.,
Senior Advisor to 5th ARVN Infantry Division (RCS CSFOR-
74)

short. The division Artillery section is technically competent but falls short of effective staff action because of failure to supervise the execution of orders. In general the staff is perfectly competent to get the job done, and - their predilection for passivity notwithstanding - they will give the division commander whatever support he demands. They are individually and collectively more effective than they were six months ago. G2 is the strongest and G1 is the weakest. A chronic neglect of G1 activities is in my mind the weakest link in the ARVN, and the seemingly universal failure to adequately attend to selection, promotion, reassignment, leave and pass policies, and utilization of trained assets remains the major flaw in the total system.

d. Command and Cooperation Among Units. ARVN seems to relish complicated command arrangements with responsibilities and headquarters so intermixed that nobody knows who is in charge. This usually happens when non-divisional task forces are placed under operational control of the division. Orders keep mentioning that one unit will work "in coordination with" another unit, with nobody in firm command. Within the division this is not now a problem, although the care and feeding of attached units continues to be an internal as well as external problem. In the same vein is the problem of non-cooperation with adjacent units. Boundaries are sacrosanct and many ARVN officers apparently feel no moral responsibility for what is happening next door. Fortunately, the better commanders recognize this pitfall among subordinates and make special efforts to stimulate coordination among adjacent units. And when there is a mix of type units - Ranger, Armor, Airborne, etc., the problem is compounded. Parent "commands" such as Armor Command exert influence on personnel and technical matters even within divisional units, and this influence seems to be unfailingly bad.

e. Ability to Move, Shoot, and Communicate. The 5th ARVN Division continues to communicate better than any US division I know of. Logistical and airmobile movements are done well enough, although control of troops on a PZ under fire still has a high potential for a mob scene. Fire and maneuver is a long and complex story, and there is great variation among units in the degree of effectiveness. Firepower

MACTR-CS

10 January 1973

SUBJECT: Senior Officer Debriefing Report of COL W. F. ULMER, Jr.,
Senior Advisor to 5th ARVN Infantry Division (RCS CSFOR-
74)

is often used instead of maneuver. This has little to do with technical capability, although through disuse the 60mm and 81mm capability of some units atrophies, and artillery procedures get sloppy if command attention waivers. Nor does it have very much to do with the US Army's example of using maximum firepower to minimize casualties, although we have to take some of the blame for the stop-and-wait-for-air syndrome. Maneuver on the battlefield requires personal leadership, whereas fire support requires primarily technical skill. Fundamentally, ARVN minimizes the field leadership task whenever possible by transferring responsibility to the next higher echelon. The vehicle for this transfer process is the availability of artillery and air support. Where leadership is good, maneuver takes place in proper relationship to firepower; otherwise, fire support is substituted. The performance of armor in the division is a special case. Routinely it is not used well although the NVA/VC fear it. Tank direct fire was used recently along highway 13 with good results. But usually the commander hesitates to expose his vehicles to enemy fire, attacks with a single-vehicle front, and does not move rapidly. Lost opportunity for success is difficult to measure and cannot be neatly tallied on a briefing chart. Materiel losses are highly visible, and pressure to avoid them seems too often to stifle aggressiveness in armor units.

f. Small Unit Tactics and Techniques. The last six months have taken a heavy toll of experienced NCO's and aggressive junior officers. That is the source of most tactical problems. While unit confidence is quite high, there is still inadequate confidence in battalion organic weaponry. Eighty-one millimeter mortars are rarely used in the offensive. Use of small patrols, use of stay-behind forces, and conduct of operations at night must be increased. The NVA/VC still think the nights belong to them. Still, infantry operations are increasingly effective and the use of tactical air, artillery, and even tank fire was well integrated with maneuver during the many successful operations during the past month. Even after the bitter lessons at An Loc some artillery batteries fail to provide adequate overhead cover for ammunition. Regarding tactics and techniques, it is noteworthy that a great disparity exists among units. One artillery battery that is screwing

MACTR-CS

10 January, 1973

SUBJECT: Senior Officer Debriefing Report of COL W. F. ULMER, JR.,
Senior Advisor to 5th ARVN Infantry Division (RCS CSFOR-
74)

fuzes in by hand and therefore experiencing a high dud rate will be alongside a battery where fuse wrenches are always used and brass is policed. In other words, the "how to do it" is available within the organization, and when command pressure is applied there are few things that a company or battery cannot do correctly.

g. Individual and Unit Training. The division training center now provides a ten-week basic infantry training course with 1,100 trainees in attendance. The operation is fair overall, on a scale of good-fair-poor, and it is a pity that after ten years of US advice on training that we are still discovering some of the same flaws in ARVN training that we were discovering in the early 1960's. Here again the real problem has been the unwillingness to divert competent leaders from the battlefield to the training field. Unit retraining at company level (such as the two-week exercises being conducted by a US-ARVN training team) is needed and should be a continuing program.

h. Supply and Maintenance. BG Lich, the Division Commander, has made astounding progress since September in improving the two areas needing greatest attention: personnel management and logistics. They will continue to require command attention. All supply systems need pressure from both ends, and subordinates in ARVN units don't yell loud enough when requisitions are not filled. Units are reluctant to turn vehicles in for repair because they would rather have a truck on hand with a leaky radiator than have no truck at all because the maintenance system somehow never seems to get the truck back to them. On the supply economy side, there is none among the soldiers except that which is meticulously enforced. I can see no generalized progress whatsoever--from 1964 when I was an ARVN Infantry Regimental Advisor until today--regarding the typical soldier's inattention to field sanitation or conservation of resources. His view of the universe is such that these acts are, in his military environment, unnatural. On the other hand, ARVN soldiers will respond both tactically and administratively if they think their leaders are serious about something. If, as in some cases, there is a self-oriented staff officer on one end of the supply system, and a long-suffering fatalist on the other, only the constant attention of a dedicated and compassionate

MACTR-CS

10 January 1973

SUBJECT: Senior Officer Debriefing Report of COL W. F. ULMER, JR.,
Senior Advisor to 5th ARVN Infantry Division (RCS CSFOR-
74)

commander can make the system work. We must continue to interest all ARVN commanders in logistics details. This interest must be generated from the top.

i. The Infantry Regiments. All three regiments can do the job although the 9th is still stumbling periodically--with a few NVA outfoxing companies led by inexperienced ARVN lieutenants. The commanders are basically sound, the executive officers good, the staffs weak and a bit weary. Company commanders vary but are generally dependable and sometimes highly aggressive. But one good officer is about all that is left in each company and when he is absent everything stops. Desertion rates continue to be typically high, and that will continue until personnel policies and good junior leaders catch up with the legitimate needs of the troops. The infantry battalions are still putting more than 400 men in the field which is the best in the division's history. Most units are equipped quite well; however, there are shortages of PRC-25 radios and compasses, and one or two men in each platoon wear steel helmets without the benefit of helmet liners.

j. The Artillery. Division artillery could use a more aggressive commander. One battalion commander and a couple of the executive officers are outstanding by any standards; one is steady but slow; one is probably a crook; and one is a coward. When the commanders are straight so are the units. Unsupervised from above, the artillery soon gets sloppy: wire is not laid to the gun positions, registration is not conducted, ammunition is unprotected, and antennae are not properly assembled. Good SOP's do not exist. Units rely too heavily on engineer support to improve their positions. The officers are well schooled but the units need refresher training to compensate for combat losses of many personnel. Counter-battery operations are improving but I know of no good system for locating individual enemy guns or rocket launchers. In summary the artillery could be a lot better but still provides relatively reliable support and puts a lot of explosive on the target, with every round fired accounted for in briefings at least once a day.

MACTR-CS

10 January 1973

SUBJECT: Senior Officer Debriefing Report of COL W. F. ULMER, JR.,
Senior Advisor to 5th ARVN Infantry Division (RCS CSFOR-
74)

k. The Engineers. Generally, the unit does well. Division staff cannot seem to stop the habit of tasking the engineers to provide a bulldozer here and a bulldozer there instead of giving the battalion a mission and letting the battalion commander select the equipment to be used. The unit is short dump trucks (because of maintenance backlog based in part on a shortage of repair parts) as well as experienced officers. The shortages seem equally important although the commander is more concerned with the trucks.

l. The Cavalry Squadron. Since their defeat at Loch Ninh the squadron has been piecemealed and generally unmobile. I am not sure what it can do. Now and then a platoon bursts forth with a surge of shock action, but routinely the performance of ARVN armor is unimpressive.

d. Advisory Philosophy and Methods:

a. Division Combat Assistance Team Staffing. In early May the DCAT consisted of 35 officers and men. As of mid-December the team had 10 personnel authorized and 13 assigned, with three of the officers serving as regimental advisors. For this stage of Vietnamization, DCAT strength of 10-15 is about right, understanding that at least half of the effort must be devoted to nonadvisory housekeeping and recording chores. Everybody remains fascinated with current tactical operations, where advice to ARVN is least necessary and the effects most transitory. Team staffing and daily emphasis had to be refocused to ensure that US expertise in personnel systems and logistics--where in fact ARVN's needs are greatest--was being employed.

b. Situational Realities and Advisory Philosophy.

(1) In general, as US resources in support of ARVN operations dwindle, so does US influence in the field. (I say "in general" because there are a few advisor-counterpart relationships where mutual respect and congruence of professional objectives result in considerable US influence on a person-to-person basis--quite apart from the more typical quid pro quo basis.)

MACTR-CS

10 January 1973

SUBJECT: Senior Officer Debriefing Report of COL W. F. ULMER, JR.,
Senior Advisor to 5th ARVN Infantry Division (RCS CSFOR-
74)

(2) ARVN is a personality-oriented institution. Because of obvious cultural and political factors, the institutionalization of ARVN has never taken place sufficiently for a commonly understood professional ethic to have taken hold. The local organization is what the local leader is. The organization remains personality-responsive, not system-responsive. Accordingly, the effectiveness of elements of the 5th ARVN Division is subject to either rapid deterioration or to swift improvement if and when key leaders are change

(3) Years ago in the advisory business we should have addressed separately the two basic components of organizational functioning: technical skill and motivation. Our advisory effort should have handled these two items consciously and explicitly as different animals, with differing expectations of susceptibility to US methods of training and influence. Instead, we often pushed hard-skill training as a solution for motivational problems; and sometimes we asked ARVN to get the job done by their trying harder when in fact the technical expertise required to do the job had not yet been developed. We have always overestimated our ability to create within ARVN a motivational base which was self-sustaining. (With a few exceptions, the abiding loyalties of all but the most westernized Vietnamese are to their families and to the first supervisor in the chain of command who reflects the trappings of traditional oriental authority.) In any commentary on ARVN strengths and weaknesses we must distinguish clearly between those shortcomings which are skill-deficient and therefore reasonably amenable to change, and those shortcomings which are motivationally-deficient and therefore less amenable to rapid change through US influence.

c. Advisory Functions in 1972. At the present time we are performing three functions in order of importance as follows:

(1) We provide a psychological boost as representative of the US commitment to the Republic of Vietnam.

(2) We assist in the employment of air assets (much of this assistance is still essential because US aircrews are being employed).

MACTR-CS

10 January 1973

SUBJECT: Senior Officer Debriefing Report of COL W. F. ULMER, JR.,
Senior Advisor to 5th ARVN Infantry Division (RCS CSFOR-
74)

(3) We provide advice on staff planning, current operations, and technical matters to our counterparts. (In this latter function we serve as an auxiliary staff to the commander, and thereby compensate to some degree for the reluctance of ARVN staff officers to isolate problems, to initiate alternative solutions, and to propose unsolicited ideas to their commander.)

5. Considerations for Future Planning:

a. US Army Weapons and Techniques. In the Binh Long Campaign and particularly in the battle for An Loc the three NVA divisions were backed by armor (T54 tanks mostly, with a few PT76, ZSU, and BTR's), light and medium artillery, and antiaircraft weapons (51 Cal, 23mm, 37mm). The tanks were employed in such a sloppy, amateurish manner that they really didn't amount to much more than good targets and psychological rallying points for our friendly troops. (Most of the three dozen tanks knocked out within the town of An Loc were destroyed by ARVN soldiers using M72's at short range; cobras got a couple; 105mm direct fire got a couple; fixed wing US and VNAF tac air got a couple; and a couple got stuck in bomb craters.) The enemy artillery was extremely effective and our attempts to locate and destroy these weapons were never fully satisfactory. We need a portable or aircraft-mounted device for locating enemy artillery and mortars. The NVA also used antiaircraft weapons effectively, and a dozen or so weapons ringing An Loc caused significant degradation of both fixed wing and rotary wing operations - with helicopters having real difficulty operating above and in and out of An Loc from late April until mid-June. Antiaircraft techniques and counter antiaircraft techniques deserve hard study as we plan for future mid-intensity operations.

b. Advisory Priorities. ARVN units, for reasons previously mentioned and for other reasons well known, are hypersensitive to the quality and attitude of officer leaders. It is now late in the game, but continuing attention to personnel matters - particularly officer selection, assignment, schooling, and promotion is essential for long term independent effectiveness - or even survivability--of ARVN.

MACTR-CS

10 January 1973

SUBJECT: Senior Officer Debriefing Report of COL W. F. ULMER, JR.,
Senior Advisor to 5th ARVN Infantry Division (RCS CSFOR-
74)

c. The Problem of Institutional Memory. We seem to keep rediscovering the wheel. I have seen techniques "discovered" in 1972 that we "discovered" in 1963. And the 1963 discovery was probably not the first one. Short tour lengths, enthusiastic advisors who might sometimes erroneously equate their unit's progress with the magnitude and dedication of their own efforts, a complex military and sociological problem, a reporting system that often emphasized only good news, and most of all a weak communications link between one generation of advisors and another, resulted in awesome inefficiencies as well as monumental successes. The solution to this perennial difficulty rests in a number of different programs, many of which appear to be starting with the new OPMS. Greater use of officer special career fields, longer tours for advisors, promulgation of criteria by which advisor efficiency is evaluated, and an overseas assignment procedure which permits some overlap between departing and arriving officers may improve the situation.

d. Advisory Duty as a Learning Experience. I would not want a steady diet of advisory assignments. Yet I cannot think of a duty other than a field advisory assignment in which there is such extensive simultaneous learning about human beings in general, yourself in particular, a foreign army, and indirectly the US Army.



W. F. ULMER, JR.
Colonel, GS
Chief of Staff



CONFIDENTIAL

Headquarters

Delta Regional Assistance Command
7th Division Combat Assistance Team
APO 96359



SUBJECT: Senior Officer Debriefing Report

28 JAN 1973

Colonel William E. Davis
Senior Advisor, 7th Division (ARVN)
RCS CSFOR - 74

THRU: Commander, DRAC
APO 96215

COMUSMACV
APO 96222

TO: Assistant Chief of Staff for Force Development
ATTN: FOR OT UT
Department of the Army
Washington, DC 20310

Country: Republic of Vietnam

Debriefing Report by: Colonel William E. Davis

Duty Assignment: Senior Advisor, 7th Infantry Division (ARVN)

Inclusive Dates: 6 July 1972 - 27 January 1973

Date of Report: 28 January 1973

1. The observations and impressions contained in this report are compiled from close daily contact with divisional counterparts in forward field command posts during a period of intensive combat operations. Other than the Division Training Center conduct of

DAMO-ODU
73B009
Inclosure 4

95

CONFIDENTIAL

CLASSIFIED BY COL William E. Davis
SUBJECT TO GENERAL DECLASSIFICATION
SCHEDULE OF EXECUTIVE ORDER 11652
AUTOMATICALLY DOWNGRADED AT TWO YEAR
INTERVALS
DECLASSIFIED ON 31 DECEMBER 1979

CONFIDENTIAL

individual training for basic replacements, none of the Divisional Combat Units were permitted the luxury of withdrawal from combat operations to conduct refresher or operational readiness training. Improvements in tactics, techniques, and combat proficiency were accomplished on-the-job.

2. On 11 June 1972, the 7th Division was committed to the Elephant's Foot area of Cambodia to stop the advance of the NVA 5th and 6th Divisions. Through the month of July the Division was committed in this area with three regiments on line in a more or less conventional posture. Air support, both tactical close air and B-52 strikes, were used extensively. Introduced in this phase of operations by the enemy was the SA-7 surface to air missile. The Division lost some 13 aircraft, to include 2 Senior Advisor helicopters shot down by 51 caliber fire trying to avoid SA7's, and a US Fac shot down by an SA7. This required a modification of technique of employment of aircraft as opposed to a change in tactics. The Fac's simply flew higher, used binoculars to spot targets, and lost no effectiveness. The helicopters flew lower, generally over secure roads or routes, and bypassed where possible known areas of SA firings. Joy-riding VR's of the area of operations became a luxury not affordable.

3. By the end of July the enemy had disengaged in this area and had withdrawn to regroup in Cambodia after suffering over 3,654 KIA and 54 captured. Success in combat was a catalyst for the division and they actively sought contact in an expanded area of operations in Cambodia from the Parrot's Beak west to Cai Cai, and in Vietnam included Kien Tuong and Kien Phong Provinces. Because of the magnitude of the area of operations, the enemy attempted and to a degree was successful in infiltrating and by-passing the Division through the Plain of Reeds. The US Air Cavalry Platoons were utilized to assist in reconnaissance and screening of the area which was by this time flooded from the rising Mekong. Complicating the problem of location and detection of enemy infiltration was the fact that the Plain of Reeds, when flooded, serves as a gigantic fishing hole for the locals and all the sampans flew the yellow flags of South Vietnam. In an attempt to overcome this, the Reconnaissance Companies of the Division were issued sampans for mobility and the VNAF light fire teams (two gunships and a C & C) would fly low-level reconnaissance over the fishing sampans. This technique was extremely successful and the area southeast of Cai Cai is dotted with destroyed VC sampans and earned the nickname Sampan Alley.

CONFIDENTIAL

CONFIDENTIAL

4. Artillery support during this period in the Mekong Delta/Plain of Reeds area of operations required movement of guns, ammunition, and personnel by air most of the time. All supplies to the units in Cambodia and west of Moc Hoa were also made by air. Complete coordination was necessary to insure the resupply of the Division with the limited air assets available. Supply discipline, to include rigid adherence to the prescribed ASR, was enforced. Detailed reconnaissance and site selection were mandatory to insure that positions remained above water or were moved ahead of the flood. In spite of all these problems in normal fire support, the Division artillery provided mobile training teams to organic units and sector artillery to train forward observers and gun crews.

5. By command emphasis and coordination the assets of the Navy and Air Force were integrated closely throughout the Division AO to provide tactical and logistical support. Armored personnel carriers of the Division Cavalry Squadron were transported around the flooded Plain of Reeds and up the Mekong River into Cai Cai by the Navy and were successfully employed in Cambodian operations to the surprise of the enemy. Both day and night naval patrols of the major canal systems were instituted to counter enemy infiltration and ammunition resupply runs were made by the Navy to artillery positions adjacent to the canals.

6. In October, the 7th Division AO was further expanded to include the area from the Mekong River south of Neak Loeang, Cambodia, east to the tip of the Parrot's Beak and the Kien Phong and Kien Tuong Provinces of Vietnam. The area was split with one regiment east of Svay Rieng and one west operating in Cambodia and the other regiment operating in RVN. To tax the command control and resupply systems further, the regiment in Cambodia west of Svay Rieng had to be resupplied by a combination of air and naval assets; the regiment east was resupplied by APC's traveling cross-country, and the regiment in Vietnam was supported over existing road and canal combinations.

7. The tactical capabilities and successes of the Division continued to improve so that by mid-December the Division area of operations was further expanded to include Dinh Tuong and Go Cong Provinces, and the 14th and 15th Regiments were attached. Enemy operations during this entire period ran the gamut from harrassment by fire to squad-sized flurries to NVA regimental size operations. The Division reaction to contact was immediate, to include artillery and air fire support and movement of reinforcing units. There have been no incidents of overrun OB's or units and the ledger reflects a most favorable friendly/enemy

CONFIDENTIAL

915'

CONFIDENTIAL

kill ratio of 7,718 enemy to 613 friendly for the period 11 June 1972 to 24 January 1973.

8. The 7th Infantry Division (ARVN) is considered the best division in the Mekong Delta and probably in the Vietnamese Army. The Division has performed in a superior fashion over an extended period of time and now can move, shoot, communicate, and fight on a par with the best of the US combat divisions.

William E. Davis
WILLIAM E. DAVIS
Colonel, Infantry
Senior Advisor

CONFIDENTIAL

96

CONFIDENTIAL

HEADQUARTERS
ADVISORY TEAM 60 (9TH DIVISION)
Delta Regional Assistance Command
APO 96215

MACDR-60-CO

24 January 1973

SUBJECT: Senior Officer Debriefing Report
Colonel THEODORE C. WILLIAMS, JR.
Senior Advisor, 9th Division (ARVN), RCSCS FOR-74

THRU: Commander, BRAC ^{5/1/73}
~~APO 96215~~

THRU: COMUSMACV
APO 96222

TO: Assistant Chief of Staff for Force Development
ATTN: FOR OT UT
Department of the Army
Washington, DC 20310

Country: Republic of Vietnam Debriefing Report by:
Colonel THEODORE C. WILLIAMS, JR.

Duty Assignment: Senior Advisor, 9th Infantry Division (ARVN)

Inclusive Dates: 15 Feb 72 to 23 Jan 73

Date of Report: 24 Jan 73

1. (U) The following report is submitted in accordance with AR 525-14, dated 2 Jul 71. Professional judgements expressed in this report are my own and in most cases are supportable by specific, personal, direct experiences.

2. (U) Commentary is limited primarily to tactical operations at Division/Province and lower levels, including both RVNAF and US operations and the US Advisory effort. Experiences related here were derived during a period of high operational intensity, to include the reintroduction of US air and naval gun-fire support and concurrent rapid, significant US tactical advisory strength reductions.

DAMO-GDU
73B010
Inclosure 5

CONFIDENTIAL

CLASSIFIED BY COL Theodore C. Williams, Jr.
SUBJECT TO GENERAL DECLASSIFICATION
SCHEDULE OF EXECUTIVE ORDER 11652
AUTOMATICALLY DOWNGRADED AT TWO YEAR
INTERVALS
DECLASSIFIED ON 31 DECEMBER 1979

97

CONFIDENTIAL

9TH INFANTRY DIVISION (ARVN)

(C) During 1972, the 9th Div accomplished all of its assigned missions in the various areas of operations. Although suffering some local defeats (heavy casualties to a few maneuver battalions), it always recovered and continued operations.

(C) Organization and operation of ARVN units is one echelon below the intended organization. That is, battalions are run like companies, regiments like battalions and the division like an over sized brigade, i.e: division plans regimental operations. Below rifle company level there is little formal organization. This is predicated on several factors:

- lack of numbers and qualified NCO's and junior officers,
- lack of "paddy" strength in maneuver battalions (60-70% TOE),
- constant turnover of personnel due to casualties, desertions.

(C) Maintenance of strength throughout the year was adequate from point of numbers with maneuver battalions fluctuating somewhere between 350 and 450 present for operations in the field. Casualties and desertions produced an unacceptable level of turnover in units. Desertions in the 9th Division were probably encouraged by the mobile role of the division. In addition, as losses were replaced by a greater percentage of former deserters who repeated, the probability of incurring high desertion rates increased. The desertion problem is an amalgam of such deep-seated factors as the national will, quality of leadership, education and discipline of the population; therefore, the problem will take generations to solve and is largely beyond the capability of RVNAF to solve completely internally.

(C) Leadership in the 9th Division is a major problem in that leaders are inadequate in numbers and quality. Typically there is a very thin strata of excellent officers at each echelon. In this case, an excellent division commander (and atypically) an excellent AOC, excellent regimental commanders, and a majority of battalions with excellent commanders. Unfortunately, each echelon is about one deep in excellence. In addition to contributing to over centralization in decision making, the situation presses commanders to use subordinate leaders until they are killed or worn out. Currently ARVN (and the 9th Div is no exception) cannot get ahead of the leadership requirement curve, since ARVN supplies district, province, RF, police and other leaders and staffs as well as trying to staff its own recently expanded, leader-short, force and concurrently replace casualties.

- The effects of leader starvation are seen most vividly at the maneuver battalion level, where large groups of young replacements are controlled with a thin leader veneer. The units become very fragile, tending to lack aggressiveness, responsiveness to command, and over-all integrity when faced with, say, a surprise attack. They have disintegrated when the battalion or company commander became casualties.

- Leaders above battalion level, particularly at regiment, do not visit

CONFIDENTIAL

or get on the ground enough with the battalions. It is difficult for regimental commanders to control and visit widely dispersed units; however, it can be done in most areas by helicopter, road, boat, or walking. Currently, in the 9th Div, the troops in the field are visited more by the Division Commander than by the regimental commanders.

(C) Command and control

- Command and control is over centralized and compartmented. In view of current leadership shortage some centralization is required.

- The formation of temporary task forces of RF/PF and regular forces operating in the same objective area is an essential but apparently difficult concept for some Vietnamese to execute. The practice is generally to draw a boundary between adjacent forces allowing the multiple chains of command to exist and operate on a "cooperative" basis. This technique denies unity of command and seriously hampers fire support and maneuver coordination. It also tends to waste assets, as individual forces search the same areas in rotation rather than a large area at one time.

(C) Mobility of the division is excellent. It has demonstrated the capability to move battalions from area to area by boat, air, foot, truck and a combination of these. The division has shown an excellent capability to move in its entirety from area to area, having changed AO three times in one year

(C) Maneuver of division elements is less than desirable in many cases. A product of middle leadership shortage, battalions go generally where they are instructed to go; however, they may be careless in flank security, move too quickly on too narrow a front, not move to contact and fail to pursue. There seems to be an unwritten rule that pursuit and assaults will be delayed until maximum air and artillery has been applied. On the other hand, some of the best results have been attained when weather has prevented the application of close air support, and the battalions have conducted assaults early after contact. Contributing factors to the ARVN maneuver problem are troop fatigue caused by excessively heavy individual equipment loads borne in the field, by excessive time in continuous operations, and by reluctance to incur casualties.

(C) Fire support and firepower in general is employed on as massive a scale as possible; often over employed. In general, the organization and application of artillery and air support is excellent. Mortars and recoilless rifles are carried in the field by maneuver units. During the period of this report, artillery ammunition consumption has improved (lessened) markedly because of limitations placed on artillery by ammunition shortages.

(C) VNAF close air support is outstanding, possibly the best in the world for accurate precision bombing. VNAF helicopter support and organization are suffering problems to be expected in any newly formed operating unit. Performance is dependent largely on the personal motivations and discipline of each VNAF pilot, hence quality of support and responsiveness is extremely uneven. The sense of mission is not fully developed in this helicopter force; however, the trend has been one of improvement. Specific problems include such things as:

CONFIDENTIAL

- failing to fly over "hot" areas even when directed to do so by the ground commander.

- a lack of comprehension among many VNAF personnel of what the average "paddy" soldier does and what he has to face in accomplishing his mission.

- not being flexible enough to report at unusually early or late times for specific operations and refusing to forego or postpone the lunch period in order to accomplish the mission. VNAF medical evacuation has a notoriously low responsiveness to ground force requirements often failing to accomplish the evacuation mission at all or doing so days after required.

- Division and regimental commanders feel a sense of frustration at this situation. There is a channel through which complaints (and compliments) can be expressed and this is being used. Ground commanders see little they can do personally and observe that the corrective system is slow.

(C) Training

- Operational readiness training within the division was limited primarily because the 1972 VC/NVA offensive required maneuver and fire support units to be nearly 100 percent committed to combat operations.

- The Division Commander fully supported the training effort and consistently filled quotas for programmed leader, specialist and unit refresher training. The Division Training Center, cited as being one of the best in the RVN, is well managed and is producing acceptable training. This is largely due to the Division Commander's emphasis and interest in training.

(C) Communications within the 9th Division was excellent. The system was employed in a variety of situations, most including extended distance between stations. By a flexible use of relay points, "jump" CP's and other techniques, the inherent capabilities of the communications equipment were exploited to a maximum.

(C) Supply of critical major items has not been a problem for the 9th Division. The division is and has been short of some wheeled vehicles; however, shortages such as these have not affected combat capabilities. Some items of individual clothing and equipment such as helmet liners have on occasion been in short supply. In most cases these have been nation wide shortages. In mid 1972, 105 ammunition became critically short country wide; however, the resulting drastically reduced authorized ASR did not impair operations. In fact, over all, the reduction in firing may have been beneficial by reducing H&I fires and introducing a certain amount of fire discipline which had been lacking in the system.

(C) Distribution of supplies is accomplished by all means available and has rarely presented a critical problem. The system is flexible and somewhat complicated but logisticians and commanders are generally skillful in using it.

(C) Maintenance of major items remained at acceptable levels. Weapons such as M113 and artillery were maintained at US levels while many wheeled vehicles,

CONFIDENTIAL

although kept running, would have been deadlined by US standards. Lower level maintenance tends to be pushed up an echelon or two, with much operator and organizational maintenance being performed at division and higher levels. Although generally adequate to meet the demands placed upon it during the 1972 offensive, the maintenance system suffers from such problems as:

- reluctance on the part of commanders to turn unrepairable vehicles in.
- uneven ability to obtain tires, batteries and other high use items.
- avoiding the system by taking vehicles "on the market" to get more timely repairs.
- inability to obtain parts for low use items because demand has not been established for them (bulldozer road wheels).

- maintenance of individual and crew-served infantry weapons remained generally high. Individuals took good care of weapons even under adverse conditions in the field (chest high water operations). Some items of individual equipment such as helmet liners, ponchos, webbing, etc. were not well suited to withstand the constant immersion and rotting induced by Delta water operations. In addition some items such as ponchos found use in many unintended although necessary roles: body bag, shelter half, raft skin, etc.. Considering these factors in addition to the high personnel turnover rate, unusual replacement rates for some items were experienced.

(C) Medical services in the 9th Div were good. Units were evenly covered by professional personnel; although, the medic per man ratio was somewhat lower than the US experience. US advisory personnel depended on initial ARVN medical care and in every case it was found to be excellent. Medevac was accomplished by all means. In some cases, the combat situation prevented timely evacuation. Aerial medevac by VNAF was sporadic, scarce and often untimely. The situation is a product of interservice coordination problems and the developing capabilities of a young helicopter force.

(C) Engineer support was responsive and effective although not enough to meet requirements. The 9th Division, being the mobile division in the Corps, repositioned many times into new areas of operation. This created a massive requirement for engineer supported fire base construction, which, with other requirements, over loaded the division engineers. Nonetheless, they were employed intensively and efficiently.

(C) Intelligence system is comprehensive, complicated and therefore difficult to manage. The 9th Division intelligence system is properly organized and equipped. In the main, intelligence personnel are knowledgeable in intelligence techniques and the use of technical intelligence resources such as RDF. Division troops depend on both the 9th Division and GVN systems to produce intelligence on VC/NVA dispositions. The total intelligence output is generally accurate; however, it is rarely timely enough to insure a high probability of contacts in the field. On several occasions, hard information was produced and within a few hours troops committed and contacts made. These cases were primarily PW's reporting the locations of units which they had left only hours

CONFIDENTIAL

before. The capability to act quickly is good. The probability of contacts based on intelligence is small. It proved generally accurate enough to allow troops and firepower to be applied to spoil and preempt VC/NVA planned operations and campaigns.

CONFIDENTIAL

102

CONFIDENTIAL

US ADVISORY/COMBAT SUPPORT OPERATIONS

(C) The long line of US advisors who have worked to produce a strong, viable RVNAF can look with great pride on their accomplishments. During the final phases of the effort, it was a major objective of the 9th Division Advisory Team to insure that when the mission was completed, the officers and men of both the 9th Division and the advisory team could with mutual respect and admiration part with a sense of mission well done. The following selected observations are provided to give insights into areas which need improvement, possibly for future Army advisory assistance missions.

(C) Fire support

-US tactical and B-52 support made distinct contributions to the successful accomplishment of 9th Division missions. Close air was accurate and well directed; however, rules governing its use, and lack of certainty of availability both restricted its use and tended to require the scheme of maneuver to support the fire support means. Rules of engagement were well founded and necessary; however, in most instances they were over strictly applied.

(C) Advisory assistance

-A "we-they" advisory relationship was too much in play between some American tactical unit and province advisors who rather consistently maligned regular force units and operations. This was an initial impression which, as time passed and the Division Advisory Team moved from one AO to the next, was confirmed.

-In many respects Americans continued to be overinvolved in what should have been by then RVNAF and Vietnamese operations. For example, there was a reluctance, particularly prevalent among province advisory groups and in some more senior American officers, to let Vietnamese counterparts make decisions regarding the application of US air power. This reluctance to "let go of the war" manifested itself in those officers who continued to think of the divisions or provinces being "their" own or "yours". The total effect was to retard Vietnamization.

-There was a reluctance on the part of higher US HQ to rely on RVNAF data and reporting systems, even beyond the point that the US capability at the lowest echelons had become nil.

-Some US tactical advisors did not have a sense of mission unless they had been advisors previously; they did not know what their relationship to the counterpart unit/commanders should be. Inability to identify with the advised unit and willingness to share its dangers and successes, and to depend on it for personal security was particularly evident among those who had been in combat in the RVN with US units and who had not been advisors previously.

-Many advisors, particularly the MCO's, did not and often refused to relate to ARVN personnel. Many similarly insisted on maintaining a "US atmosphere" around them thus unnecessarily prolonging excessive US logistical support requirements.

CONFIDENTIAL

-Small advisory teams should be composed of all officers to maximize the advisory effort and to insure that US personnel are accorded an adequate standard of living. ARVN officers normally do not accept advice from NCO no matter how skilled or senior; therefore, when requirements dictate structuring every space to be an advisor space, care should be taken that all be filled with experienced selected officers. This too insures that team members will have adequate quarters, mess and support. While a US officer can be expected to live on the same basis as an ARVN officer of equivalent rank, a US NCO cannot be expected to.

-ARVN (interpreter) NCO augmentation to the advisory teams is essential to team operation and presents an unusual opportunity for the US to make a lasting impression on a relatively large number of relatively sophisticated, well educated Vietnamese. To exploit their many capabilities, ARVN augmentation personnel were integrated into the team and assumed actual operational duties, such as operations NCO, supply NCO, administrative NCO, etc.. After training, these ARVN NCO's dealt with both ARVN divisional personnel as well as with higher US HQ, US air assets, etc.. As the US element of the team dwindled, more operational functions were assumed by ARVN NCO augmentees. For these efforts, they were rewarded appropriately with ARCOM's for service and certificates of achievement. In addition, as they were tasked to a greater extent, they willingly produced even more. This nucleus of NCO's has been trained to operate with US resources and units. Consideration should be given to earmarking these men for contingency use should US support again be required.

CONFIDENTIAL

CONFIDENTIAL

MACDR-60-CO

SUBJECT: Senior Officer Debriefing Report
Colonel THEODORE C. WILLIAMS, JR.
Senior Advisor, 9th Division (ARVN), RCSCS FOR-74

3. (U) Ten years ago ARVN units kept pretty much to the province towns, going out on operations limited both in duration and size. Today, ARVN maneuver battalions are constantly in the field, constantly moving and operating. ARVN training center oriented training ten years ago was in the embryonic stage, with much program turbulence. Today, judging by the 9th Division Training Center, operations are routine, trainee flow and administration, although well over stated capacity, is being handled efficiently and effectively. These are only two examples of major improvements demonstrated by RVNAF. It is my estimate that the ARVN and the 9th Division are truly self sufficient and can be expected, with only minor continuing US advisory effort, to continue to do their part in insuring the independence of the RVN and preserve the right of the Vietnamese people to choose their own destiny. Vietnamization has succeeded in the 9th Infantry Division (ARVN). First part contains assessments of selected performance indicators.

4. (U) The US advisory effort, reinforced largely by US air support, has successfully completed its mission of assisting RVNAF to mold itself into a strong, viable force. First part contains indicators of the few areas which, if future advisory efforts are to be undertaken by the United States Army, require consideration for corrective action.

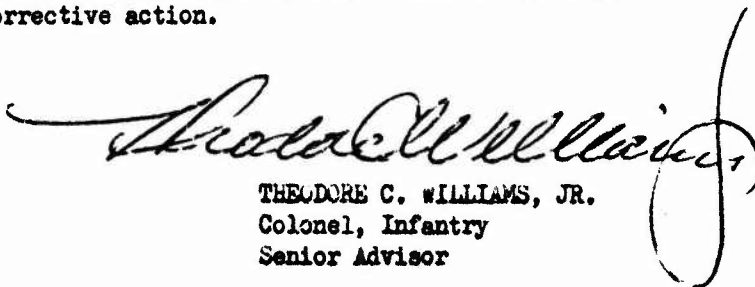
THEODORE C. WILLIAMS, JR.
Colonel, Infantry
Senior Advisor

Incl a/s

CONFIDENTIAL

CONFIDENTIAL

HEADQUARTERS
UNITED STATES MILITARY ASSISTANCE COMMAND VIETNAM
APO SAN FRANCISCO 96222



MACDO-341

16 FEB 1973

SUBJECT: Senior Officer Debriefing Report (RCS: CSFOR-74)

Assistant Chief of Staff for Force Development
ATTN: FOR OT UT
Department of the Army
Washington, DC 20310

1. Ref: AR 525-14 (C).
2. In accordance with reference as above, the Completion of Tour Report of COL Harry A. Yoder, Senior Advisor, 25th Division Combat Assistance Team, is inclosed. A copy of the subject report has been forwarded to CINCUSARPAC, for information.

John R. McGiffert
JOHN R. MCGIFFERT
Brigadier General,
Director of Operations

DAMO-ODU
73B013
Inclosure 6

CLASSIFIED BY: G3 TRAC
SUBJECT TO GENERAL DECLASSIFICATION
SCHEDULE OF EXECUTIVE ORDER 11652
AUTOMATICALLY DOWNGRADED AT TWO YEAR
INTERVALS
DECLASSIFIED ON 31 DECEMBER 1979

CONFIDENTIAL

CONFIDENTIAL

HEADQUARTERS
25TH DIVISION COMBAT ASSISTANCE TEAM, ADVISORY TEAM 99
THIRD REGIONAL ASSISTANCE COMMAND
APO San Francisco 96309

MACTR-25/SA

05 FEB 1973

SUBJECT: Senior Officer Debriefing Report, Colonel Harry A. Foder Jr.
(RCS OSFOR-74) (U)

THRU: Commander
Third Regional Assistance Command
ATTN: G3

TO: Assistant Chief of Staff for Force Development
ATTN: DAED-OTT
Department of the Army
Washington, D.C. 20310

Debriefing Report by: Colonel Harry A. Foder Jr.
Duty assignment: Senior Advisor to 25th ARVN Infantry Division
Inclusive dates: 4 August 1972 to 21 January 1973
Date of Report: 31 January 1973

1. (U) INTRODUCTION:

To understand, which is not necessarily to agree with, many of the ARVN actions or lack thereof, one must appreciate the philosophy and experience upon which they are based. I believe that many of the problems we see in ARVN have their cause, if not their solutions as well, buried in past political and socio-economic struggles.

2. (C) OPERATIONAL ENVIRONMENT

a. Area of Operations. During the period covered by this report the division found itself in three different types of operational areas:

(1) First, in Binh Long Province along Highway 13 south of an Loc between XT 7780 and south of Chon Thanh (AT 7750). The terrain was flat with tall grass (4 to 6 feet) on both sides of road developing into thick jungle at approximately 1000 to 1500 meters from the road. There were several small villages south of Chon Thanh but none to the north, east, or west within the area of operations.

CONFIDENTIAL

CONFIDENTIAL

05 FEB 1973

MACTR-25/SA

SUBJECT: Senior Officer Debriefing Report, Colonel Harry A. Yoder Jr.
(RCS OSFOR) (U)

(2) Second, in central Binh Duong Province north of Highway 313, the terrain was flat and dominated by rice paddies and some rubber with irregularly spaced draws and depressions leading into swampy areas thick with underbrush. A relatively populated area, it had numerous builtup areas.

(3) Third, southwest Binh Duong Province, Hau Nghia Province, and Tay Ninh Province.

(a) Southwest Binh Duong is characterized by heavy undergrowth to light jungle along the Saigon River. The area is commonly known as the Hobo Woods and Bo Loi Woods. Most of the population in these areas is VC controlled and it is a vital link in the infiltration routes from Cambodia through Tay Ninh into Binh Duong and south. The area was heavily booby trapped and mined and sanctuary areas had good defensive works. The river in this area is part of the main resupply route. The RVN Navy patrols the southern portion of the river just above Phu Cuong but this is largely ineffective.

(b) Hau Nghia Province is characterized by populated areas and rice paddies in the east separated from swamp in the west by the Van Co Dong river and some wooded areas along the river in the central portion of the province.

(c) Northern Tay Ninh Province is completely VC controlled and known as War Zone "C". It is composed of heavy jungle but with an extensive network of roads and trails running both west-east and north-south. South of Nui Ba Den, a prominent hill mass, the province is heavily populated with rice paddies and extensive rubber complexes. It borders Cambodia and contains Route 1.

b. Nature of the Enemy

(1) In Binh Long Province, from June to October 1972, the enemy was applying economy of force measures occupying the entire corps resources with two under strength divisions. By cutting the road between Chon Thanh and An Loc as well as between Chon Thanh and Lai Khe he enticed ARVN forces into a road opening operation which became costly to ARVN because of well prepared defenses along the road particularly at the points where the road was cut (the Tau-C River at XT 7672, and South of Chon Thanh at XT 7048). The enemy used these cuts to move troops and supplies east in preparation for the October offensive in Binh Duong Province. He defended the road and its blocks with a determined effort. When over run, the enemy cut the road at another point where ARVN forces were applying economy of force measures in order to develop sufficient combat strength to clear strong points elsewhere. The enemy's tactics here forced extensive aerial resupply and tied up a major portion of the corps armor and air assets.

CONFIDENTIAL

CONFIDENTIAL

05 FEB 1973

MACTR-25/SA

SUBJECT: Senior Officer Debriefing [redacted], Colonel Harry A. Yoder Jr.
(RCS G. FOR-74) (U)

(2) When the threat to Saigon became clear in early October, the road clearing operation was abandoned in favor of a strong point defense around An Loc, Chon Thanh, and Lai Khe/Ben Cat with minimal troops so as to release maximum combat power to defend population centers and particularly Saigon itself. In his initial assault, the enemy was successful in driving RF/PF forces from many villages particularly in Binh Duong Province. The 25th Division spent this period essentially in house to house fighting in thickly wooded villages where many houses contained well constructed bunkers that could be destroyed only by air. The enemy paid severely for this offensive but numerous villages and hamlets were destroyed in the process. When he failed to hold the population centers involved and the cease fire did not materialize, he withdrew north and west to rest and refit.

(3) From mid November until the cease fire, the enemy attempted to avoid contact with ARVN forces, resupply, and reposition himself for a cease fire or continued operations when he became strong enough to do so. Attack by fire was the order of the day. This tactic provided lucrative targets for tactical air and B-52 strikes, both of which were used effectively. On the ground, ARVN conducted traditional search and destroy operations with some success but few major victories were achieved.

3. (C) COMMAND RELATIONSHIPS: This remains one of more significant problems confronting the RVNAF. Combat effectiveness is degraded significantly because of the failure of regular forces and RF/PF forces to function as a team. Where the province chief and division commander were close, they approached a measure of unity of command. This was the exception. More often, operations of the two forces were uncoordinated. The unity of command problems will be discussed further under "Techniques of Employment".

4. (C) EXPERIENCE IN COMMAND:

a. Concept of Operation: Corps headquarters was overly dominant in this area usually outlining in detail for the division how everything should be accomplished. Boundaries were established arbitrarily according to grid lines often without regard for critical terrain features or provincial boundaries. During the period covered by this report, a defensive attitude on the part of the ARVN precluded the conduct of effective offensive operations which were called for to exploit friendly successes.

b. Command and Control: There still remains to a significant degree an inability of division and regimental commanders to assure that their orders are being followed, particularly as regards subordinate units actually going where they are supposed to go, doing what they are supposed to do once they get there, and then accurately reporting their activities in a timely manner. There are instances where subordinate commanders actually refuse or ignore orders if they disagree with the concept or feel the risk is too great. This is particularly true where a subordinate unit is not organic to the controlling headquarters.

CONFIDENTIAL

CONFIDENTIAL

05 Feb 1973

MACTR-25/SA

SUBJECT: Senior Officer Debriefing Report, Colonel Harry A. Yoder Jr.
(RCS OSFOR) (U)

c. Techniques of Employment: Cross attachment is often carried to such an extreme that units lose identity, Brigade headquarters are left without maneuver elements, and created task force headquarters have excessive span of control and inadequate experienced leadership to command the force effectively. At one point one of the division's regiments was attached to a province, another to a corps task force, and portions of the third to a task force under control of another division. Companies are passed back and forth between battalions disrupting unit integrity and inviting command and control problems which often result in ineffective operations.

d. Combat Operations:

(1) Planning is very professional due to the experience level of senior staff officers and commanders with respect to both the enemy and the terrain.

(2) Maneuver is practically non-existent as we know it in connection with the combined arms team. Armor is consistently used in a defensive posture. When employed offensively, it fails to utilize its fire power and shock action depending excessively, as the infantry does, on air strikes and artillery in an effort to keep casualties and equipment damage to a minimum. In most cases, the aggressive use of armor with an effectively coordinated fire and maneuver plan would have produced greater successes with fewer casualties and equipment losses. Part of the problem lies in the armor's being under the Armor Command even when it is attached to the Division. The attached armor unit looks to the armor command headquarters for guidance and orders. At the same time the division is reluctant to push too hard since should the losses be great, the repercussions from corps and JCS would be great. This inhibits the employment of armor in its most effective role.

(3) Fire Support: Employment of artillery was excellent.

(4) Combat Service Support was excellent.

e. Intelligence: The collection, reporting and processing of information into useable intelligence, its dissemination to subordinate units in the division in a timely manner, and their use of it has been excellent. Intelligence received from higher headquarters has become less timely since departure of US intelligence units and therefore often is stale.

f. Training:

(1) The division training center concept has merit since the trainee joins his division immediately, can generally plan to fight close to his home province, and gets first hand knowledge of the divisions area of operations and the nature of the enemy in it. However, a centralized system such as utilized by the US could be expected to raise standards and be more economical both in terms of manpower and facilities. Caution would have to be exercised to assure that graduating trainees were assigned to their home areas if the AWOL rate is not to increase.

CONFIDENTIAL

CONFIDENTIAL

05 FEB 1973

MACTR-25/SA

SUBJECT: Senior Officer Debriefing Report, Colonel Harry A. Yoder Jr.
(RCS OSFOR) (U)

(2) There is a need for NCO and junior officer training. Programs are being conducted to meet this need.

g. Personnel Management:

(1) Unit strengths are down somewhat from six months ago due to the continuous combat experienced by the division during the enemy's recent offensives. Deserter figures have played a large role here also. Recruitment by the division and subsequent graduations from the training center have not kept pace with casualties/desertions. However, foxhole strength in relation to support personnel has remained high.

(2) Morale, health, and welfare is surprisingly high considering continuous operations in the field for over a year.

(3) Discipline, law, and order is excellent. There were some allegations of looting during the Binh Duong operations but sufficient evidence was never produced to indicate clearly that it was regular forces as opposed to RF/PF or VC/NVA forces or civilians themselves. Prompt action was initiated by the division hopefully to preclude recurrence if in fact divisional forces were involved.

h. Logistics: Personnel in this field are efficient and experienced. The cause of major shortages can be traced to higher in the system or a non-availability country-wide.

i. Base operations/defense is effectively conducted. Minimal combat troops are used for these purposes.

j. Communications are outstanding in all respects.

k. Psychological operations are well planned and continuous.

5. (C) CONCLUSION: The war and being an "ARVN" is a way of life for the people here. It is all that they have experienced and all that many feel they can look forward to realistically. The philosophy shared more commonly in the lower grades and enlisted ranks-is-try to live long enough to be retired (since everyone is in for a "duration" which has no visible end to them). However it is these people at squad, platoon and company level that largely determine the effectiveness of a force, particularly in isolated areas where a command and control helicopter just can't live. The personal impatience for victory which motivates American aggressiveness, and a past which generates confidence, are just not part of the average ARVN's thought processes, even though his senior leadership understands the military soundness of such an approach.

CONFIDENTIAL

HARRY A. YODER JR.
Colonel, Infantry
Senior Advisor

CONFIDENTIAL

HEADQUARTERS
UNITED STATES MILITARY ASSISTANCE COMMAND, VIETNAM
APO SAIGON 96222



21 FEB 1973

MACDO-341

SUBJECT: Senior Officer Debriefing Report (RCS: CSFOR-74)

Assistant Chief of Staff for Force Development
ATTN: FOR OT UT
Department of the Army
Washington, DC 20310

1. Ref: AR 525-14 (C).
2. In accordance with reference as above, the Completion of Tour Report of COL John C. Evans, Senior Advisor, 18th Division Combat Assistance Team, is inclosed. A copy of the subject report has been forwarded to CINCUSARPAC, for information.

John R. McGiffert
JOHN R. MCGIFFERT
Brigadier General, USA
Director of Operations

DAMO-ODU
73B022
Inclosure 7

CLASSIFIED BY SA, 18th DCAT
SUBJECT TO GENERAL DECLASSIFICATION
SCHEDULE OF EXECUTIVE ORDER 11652
AUTOMATICALLY DOWNGRADED AT TWO YEAR
INTERVALS
DECLASSIFIED ON 31 DECEMBER 1979

Not Releasable to Foreign Nationals

CONFIDENTIAL

CONFIDENTIAL

HEADQUARTERS
18TH DIVISION COMBAT ASSISTANCE TEAM, ADVISORY TEAM 87
THIRD REGIONAL ASSISTANCE COMMAND
APO San Francisco 96266

SUBJECT: Senior Officer Debriefing Report (Colonel John C. Evans),
RCS CSFOR-74 (U)

THRU: Commanding General, Third Regional Assistance Command, APO San
Francisco 96266.
COMUSMACV, APO San Francisco 96222

TO: Assistant Chief of Staff for Force Development
ATTN: FOR OT UT
Department of the Army
Washington DC 20310

Debriefing Report by: Colonel John C. Evans, 297-18-2895, Infantry

Duty Assignment: Senior Advisor, 18th Infantry Division, ARVN

Inclusive Dates: 19 July 1972 to 1 February 1973

Date of Report: 1 February 1973

1. (C-NOFORN) Introduction. Prior to July 1972 the 18th Infantry Division, ARVN, had been assigned the role of General Reserve, and its regiments were normally widely dispersed in the four provinces (Bien Hoa, Long Khanh, Binh Tuy and Phuoc Tuy) east of the capital city of Saigon. The NVA Spring-Summer Offensive of 1972 caused the traditional reaction role to be continued through the months of April, May and June. In early July 1972, one week prior to the writer's assignment as Division Senior Advisor, the 18th Division was inserted by US aviation resources under fire into An Loc, Binh Long Province, to relieve the battered 5th Infantry Division, ARVN, which with massive US tactical air and B-52 support had defeated the efforts of three NVA divisions (the 5th, 7th and 9th), to seize the city. It was the first time the division headquarters and all the regiments were committed to a common mission. The mission, given directly by President Thieu, included: (1) Defend the provincial capital at all costs to deny the NVA/VC a recognized "capital"; (2) Deny the enemy the propaganda which could be derived from the launching of another major attack with accompanying world-wide publicity; and (3) Regain critical terrain which had been lost to the enemy in April, May and June ("critical" in this instance being applied to "name" places such as Quan Loi Airfield rather than to critical terrain as we use the term). The division remained in the An Loc Area until late November, when it was relieved and once again redeployed at widely dispersed locations in the defense of the capital city, the approaches thereto, and the major airbases of Bien Hoa and Tan Son Nhut. It operated in this role through the Cease Fire which found its battalions reinforcing regional and popular force units in repelling the enemy's "landgrab" efforts.

CONFIDENTIAL

CONFIDENTIAL

SUBJECT: Senior Officer Debriefing Report (Colonel John C. Evans),
RCS CSFOR-74 (U)

The four and one-half months of operations in An Loc, where the division was isolated from friendly forces and totally dependent on aerial resupply, afforded a unique opportunity to view the division. In this report I will assume the readers are knowledgeable of the ARVN organization, the Vietnamization Program, the diminishing US advisory effort, and overall strategic situation of the period. I will generally address the characteristics of the South Vietnamese encountered at Division Level and below, the effectiveness of the division staff, the division artillery, and the infantry regiments, and will conclude with selected observations applicable at this time of Cease Fire.

2. (C-NOFORN) The Characteristics of the South Vietnamese. This paragraph will not attempt to address the characteristics of the South Vietnamese as a whole but will address those facets which impact on day-to-day military operations, working relationships, and the accomplishment of assigned missions.

a. Deference to rank in many instances destroys unit effectiveness, as regimental commanders and key staff officers will not defend, and in some cases not even submit, recommendations on matters in which they have greater knowledge than the commander, simply because "he is senior." The situation carries over into staff relations as well; e.g., a division G4 will not admit logistical problems to corps or higher level G4's, but will blithely infer no problem exists and then return to struggle unsuccessfully with it. The same rank-is-right philosophy applies in reverse when many senior officers assume their staff and/or subordinate commanders are incompetent and could not survive unless all of their decisions are made for them. In some instances combat operations lose their effectiveness as the division commander enters battalion command nets and gives orders which differ from those of the regimental commanders.

b. The lack of a sense of urgency is one trait which I found extremely frustrating. Time and again there was a hesitancy to exploit success or to assist units in danger of being defeated piecemeal. Closely related to this is a near total lack of concern for contiguous units which are not part of the division. The cavalier attitude that "they got themselves in trouble, now they'd better get themselves out of it" applies, rather than seizing the opportunity to mass combat power against an enemy force that has been located.

c. Command presence, which is ingrained in the US Army Officer Corps, has little application with the majority of the South Vietnamese I encountered. Many are content to sit in a command post with maps and radios rather than to make on-scene evaluations, encourage the troops, etc. This attitude is in my opinion attributable to their thought that over many years of war, Vietnam has lost so many of its high caliber personnel that those surviving must save themselves for the long haul. There is also a concern that the

CONFIDENTIAL

CONFIDENTIAL

SUBJECT: Senior Officer Debriefing Report (Colonel John C. Evans),
RCS CSFOR-74 (U)

death of a senior officer provides a psywar advantage which the enemy can cleverly exploit against the ARVN soldiers.

d. Though considerable progress was noted during the assignment there is still far too little concern for the welfare of the troops in such basic areas as shelter, field sanitation, pay discrepancies, personal problems, and dependant housing.

3. (C-NOFORN) The Effectiveness of the Division Staff. The characteristic discussed above which degrades the efforts/capabilities of subordinates is particularly applicable in the relationship of the division commander with the division staff. The normal staff planning sequence common to our Army is totally ignored the majority of the time. The commander receives an order from higher, gives his order without calling upon the staff for estimates, and uses them merely to support the implementation of his order. Perhaps the single exception is that the G2 is called upon to provide enemy information, but that is all. After considerable urging by the undersigned the staff is being utilized to a greater degree and is receiving more guidance and training on staff coordination. However, in time of crisis the commander reverts to type and centralizes control.

4. (C-NOFORN) The Division Artillery. Great progress has been made in the employment of artillery. The single gun at a given location which was common during the early days of the war has been replaced by effective massing of fires, the use of TOT's, the inclusion of fire support in planning, etc. A large share of credit in this improvement must be given to artillery advisors who taught by example. Due to the harsh lessons of An Loc the division artillery is extremely adept at rapidly developing good fire bases with overhead protection for ammunition, and fire direction centers. The single major weakness is the lack of a sophisticated counter-artillery or counter-rocket capability. While counter-battery systems are in existence, those in the hands of the Vietnamese are restricted to defense of the capital rather than placed in the hands of the divisions in contact. The ARVN artillery battalion commanders seem to be above average in intelligence and initiative.

5. (C-NOFORN) The Effectiveness of the Infantry Regiments. The infantry regimental commanders range from good to excellent and have vast experience over this protracted war. Many, though, are on the verge of exhaustion from prolonged combat, multiple wounds, etc. The regimental executive officers are almost a new breed; experienced, yet enthusiastic; they may well be keys in the post-hostilities defensive role. The regiments are at probably their best present-for-operations posture at this time with each battalion fielding over five hundred troops. The shortage of good junior leaders, both officers and non-commissioned officers due to combat attrition, continues to present a major problem. Efforts are being made to rectify this situation through NCO courses and Battalion Refresher Training at

CONFIDENTIAL

CONFIDENTIAL

SUBJECT: Senior Officer Debriefing Report (Colonel John C. Evans),
RCS CSFOR-74 (U)

the Division Training Center.

6. (C-NOFORN) Miscellaneous Observations. The following observations, though not inter-related, are believed worth commenting upon:

a. The Vietnamese I observed seem to be incapable of effective combat operations above division level to include the attaching of elements of one division to reinforce another. There are several reasons for this deficiency.

(1). Mutual distrust among divisions; i.e., it is believed that elements attached to another division will be given the most difficult combat missions, will be denied adequate supporting fires and logistical support, and will not receive recognition for accomplishments.

(2). Possibly as a result of the preceding, commanders do not perform as effectively when they are detached from their normal chain of command; they seem to feel that these periods of attachment must be endured with minimum casualties until the order to return to the parent unit is received.

(3). The lack of concern for non-divisional units in contact as addressed in paragraph 2 above.

b. Training centers below corps level cannot be adequately staffed without aggravating the already serious shortage of combat-experienced junior officers and non-commissioned officers. Consolidation at corps or national level, which would also contribute to standardization of training, is recommended. Such consolidation would, however, require consideration of the fact that divisions recruit their own replacements. Personnel sent to the higher level training centers eventually must arrive at the division for which they were enlisted or the recruiting program must be revised.

c. Command and control procedures are made unnecessarily complex with unit redeployments frequently occurring for little purpose. The related principle of unity of command is violated routinely with commanders being called upon to defend in multiple directions and with external units interspersed within their area of operations.

7. (C-NOFORN) The Vietnamese Capability Today. At this time of Cease Fire, it can be unequivocally stated that the 18th Infantry Division, ARVN, is capable of sustained combat without US advisors.

John C. Evans
JOHN C. EVANS
Colonel, Infantry
Commanding

CONFIDENTIAL

UNCLASSIFIED

Security Classification

DOCUMENT CONTROL DATA - R & D

(Security classification of title, body of abstract and indexing annotation must be entered when the overall report is classified)

1. ORIGINATING ACTIVITY (Corporate author) DA, DAMO-ODU Washington, D.C. 20310		2a. REPORT SECURITY CLASSIFICATION Confidential	
		2b. GROUP	
3. REPORT TITLE Senior Officer Debriefing Reports: Senior Advisors, ARVN 1st, 3rd, 5th, 7th, 9th, 25th, and 18th Infantry Division, Period Ending February 1973 (U)			
4. DESCRIPTIVE NOTES (Type of report and inclusive dates) Senior Officer Debriefing Reports - Period Ending February 1973			
5. AUTHOR(S) (First name, middle initial, last name) COL George Millener, Jr. COL William Davis COL John C. Evans COL C. B. McCoid COL Theodore Williams, Jr. COL W. F. Ulmer, Jr. COL Harry A. Yoder			
6. REPORT DATE 15 March 1973	7a. TOTAL NO. OF PAGES 106	7b. NO. OF REFS	
8a. CONTRACT OR GRANT NO.	8b. ORIGINATOR'S REPORT NUMBER(S) 73B011 73B009 73B022 73B014 73B010 73B006 73B013		
9. PROJECT NO. N/A	8c. OTHER REPORT NO(S) (Any other numbers that may be assigned this report)		
10. DISTRIBUTION STATEMENT			
11. SUPPLEMENTARY NOTES N/A		12. SPONSORING MILITARY ACTIVITY DA DAMO-ODU Washington, D.C. 20310	
13. ABSTRACT			

DD Form 1473

UNCLASSIFIED

(This page is unclassified)