

UNCLASSIFIED

AD NUMBER
AD509166
NEW LIMITATION CHANGE
TO Approved for public release, distribution unlimited
FROM Distribution: Further dissemination only as directed by Assistant Chief of Staff for Force Development [Army], Washington, DC 20310, 28 Feb 1976, or higher DoD authority.
AUTHORITY
OAG D/A ltr, 29 Apr 1980

THIS PAGE IS UNCLASSIFIED

UNCLASSIFIED

AD NUMBER

AD509166

CLASSIFICATION CHANGES

TO: unclassified

FROM: confidential

LIMITATION CHANGES

TO:

Distribution: Further dissemination only as directed by Assistant Chief of Staff for Force Development [Army], Washington, DC 20310, 28 Feb 1976, or higher DoD authority.

FROM:

Controlling DoD Organization... Assistant Chief of Staff for Force Development [Army], Washington, DC 20310.

AUTHORITY

28 Feb 1976, GDS, DoD 5200.1-r; DoDD 5230.24, 18 Apr 1987

THIS PAGE IS UNCLASSIFIED

SECURITY

MARKING

The classified or limited status of this report applies to each page, unless otherwise marked.

Separate page printouts MUST be marked accordingly.

THIS DOCUMENT CONTAINS INFORMATION AFFECTING THE NATIONAL DEFENSE OF THE UNITED STATES WITHIN THE MEANING OF THE ESPIONAGE LAWS, TITLE 18, U.S.C., SECTIONS 793 AND 794. THE TRANSMISSION OR THE REVELATION OF ITS CONTENTS IN ANY MANNER TO AN UNAUTHORIZED PERSON IS PROHIBITED BY LAW.

NOTICE: When government or other drawings, specifications or other data are used for any purpose other than in connection with a definitely related government procurement operation, the U.S. Government thereby incurs no responsibility, nor any obligation whatsoever; and the fact that the Government may have formulated, furnished, or in any way supplied the said drawings, specifications, or other data is not to be regarded by implication or otherwise as in any manner licensing the holder or any other person or corporation, or conveying any rights or permission to manufacture, use or sell any patented invention that may in any way be related thereto.

CONFIDENTIAL

**DEPARTMENT OF THE ARMY
OFFICE OF THE ADJUTANT GENERAL
WASHINGTON, D.C. 20310**



IN REPLY REFER TO

AGDA (M) (23 Apr 70) FOR OT UT 701046 28 April 1970
SUBJECT: Operational Report - Lessons Learned, Headquarters, United States Army Vietnam, Period Ending 31 January 1970 (U)

SEE DISTRIBUTION

1. Subject report is forwarded for review and evaluation in accordance with paragraph 4b, AR 525-15. Evaluations and corrective actions should be reported to ACSFOR OT UT, Operational Reports Branch, within 90 days of receipt of covering letter.
2. Information contained in this report is provided to insure appropriate benefits in the future from lessons learned during current operations and may be adapted for use in developing training material.

BY ORDER OF THE SECRETARY OF THE ARMY:

Kenneth G. Wickham

KENNETH G. WICKHAM
Major General, USA
The Adjutant General

1 Incl
as

DISTRIBUTION:

Commanding Generals

- US Continental Army Command
- US Army Combat Developments Command
- US Army Materiel Command

Commandants

- US Army War College
- US Army Command and General Staff College
- US Army Air Defense School
- US Army Armor School
- US Army Aviation School
- US Army Civil Affairs School
- US Army Combat Surveillance School
- US Army Electronic Warfare School
- US Army Engineer School
- US Army Field Artillery School

JUN 10 1970

Regraded unclassified when separated from classified inclosure.

CONFIDENTIAL

AD 509 I 66

AD 509 166

PAGE 2
DISTRIBUTION

CONFIDENTIAL

DEPARTMENT OF THE ARMY
HEADQUARTERS, UNITED STATES ARMY VIETNAM
APO San Francisco 96375

AVHGC-DST

23 Feb 1970

SUBJECT: Operational Report-Lessons Learned of Headquarters, United States Army, Vietnam, Period Ending 31 January 1970 RCS CSFOR-65 (R2) (U)

THRU: Commander in Chief
United States Army, Pacific
ATTN: GPOP-DT
APO 96558

TO: Assistant Chief of Staff for Force Development
Department of the Army
Washington, D.C. 20310

1. (C) Operation: Significant Activities

a. (U) COMMAND.

(1) Commanders.

CG, USARV

1 November 1969 - 31 January 1970

GEN Creighton W. Abrams

DCG, USARV

1 November 1969 - 31 January 1970

LTG Frank T. Mildren

CG, Engineer Troops, Vietnam (Provisional)

1 November 1969 - 1 December 1969

BG Robert M. Tarbox

1 December 1969 - 31 January 1970

BG John A. B. Dillard

FOR OT UT
701046
Inclosure

1

**DOWNGRADED AT 3 YEAR INTERVALS;
DECLASSIFIED AFTER 12 YEARS.
DOD DIR 5200.10**

CONFIDENTIAL

CONFIDENTIAL

AVHGC-DST

SUBJECT: Operational Report-Lessons Learned of Headquarters United States Army, Vietnam, Period Ending 31 January 1970, RCS CSFOR-65 (R2) (U)

CG, US Army Construction Agency, Vietnam

1 November 1969 - 1 December 1969

COL William L. Barnes

1 December 1969 - 31 January 1970

BG Robert M. Tarbox

(2) Distinguished Visitor Summary. wd HQ, DA

b. (U) PERSONNEL, ADMINISTRATION, MORALE, AND DISCIPLINE.

(1) Morale and Personnel Services. Chaplain Activities. There was an increase of 72,688 personnel attending character guidance instruction

INCL

2

CONFIDENTIAL

AVHGC-DST

SUBJECT: Operational Report-Lessons Learned of Headquarters, United States Army, Vietnam, Period Ending 31 January 1970, RCS CSFOR-65 (R2) (U)

over the same quarter last year. There was also an increase of 713 character guidance instruction sessions. The percent of the Command attending weekly religious services was 20.4% compared to 18.7% for the same quarter last year. The number of services conducted per chaplain per week this quarter was 7.4 which is an increase over the 6.3 for the same quarter last year. Contributions by Chaplains' Funds to Vietnamese religious/charitable causes during 2d Quarter FY 70 totaled \$64,759.

(2) Medical Services and Medical Supplies.

(a) Surgical Care. High velocity weapons are causing extensive contusions or hemorrhage of the lungs. These casualties may develop respiratory insufficiency. Severe hypoxemia was formerly treated conservatively with poor results. Aggressive surgical removal of the contused lung tissue has resulted in survival of over 25 patients who would most likely have died under former methods of treatment.

(b) Division Optometry Support. The optometry sections which became organic to the divisions last year were initially located at base camps. Soldiers operating from forward combat areas requiring eye examination were required to come to the base camp for vision care. Many of these visits were for routine (non-emergency) problems such as verification of the adequacy of existing glasses, prescriptions, consultations for minor eye irritations or headaches, and vision tests for drivers' licenses or physical examination. The separated tactical deployments and existing transportation difficulties associated therewith, has caused significant delays in providing responsive service. Those factors have caused two-three day absences by the soldier from his unit, although the vision examination and fabrication of glasses were completed in one day. To alleviate this problem, optometry sub-clinics have been established in the forward areas to provide more responsive service for combat troops requesting routine optometric care. A number of sub-clinics are now located at the medical company supporting a brigade. Additional sub-clinics will be established within

INCL

AVHGC-DST

SUBJECT: Operational Report-Lessons Learned of Headquarters,
United States Army, Vietnam, Period Ending 31 January
1970, RCS CSFOR-65 (R2) (U)

present equipment and personnel limitations. Optometry officers organic to the division visit the sub-clinics on a periodic basis, usually one or two days a week.

(c) Quarantine Inspection of Retrograde Cargo. US military retrograde cargo shipments to CONUS must be processed in a special manner to insure compliance with US Government quarantine laws. A program for USDA/PHS/DOD inspection and clearance of retrograde cargo in RVN was implemented in the command in November 1969. Basic to this program was the premise that sufficient quantities of retrograde materiel would be available at intransit areas to insure that full shiploads could be obtained at single ports. No difficulties were envisioned in obtaining large retrograde cargo offerings under a program for rapid redeployment. However, under a policy of gradual redeployment, insufficient quantities of retrograde cargo were available and vessels have been routinely dispatched to more than one port to obtain full shiploads. This created special problems for USDA/PHS/DOD quarantine inspection and certification of cargo shipments. The arrival, loading, and departure of MSTS vessels from various ports nullified initial USPHS rodent and USDA inspection of vessels and increased the possibility for contamination of cargo by acceptance of partial loads from different areas. A special quarantine remand (referral) system was developed for USARV maritime ports. Quarantine inspectors conduct sanitary inspections on MSTS vessels after they have discharged all incoming cargo and are ready for backloading. The ship can be cleared to accept retrograde cargo for shipment to CONUS providing appropriate sanitary standards have been maintained on the vessel. The cargo manifest for a partial load can be certified by a military quarantine inspector (MQI) on duty at maritime ports. MQI's notify USARV Advisors as to the status of the vessel and the next port of call upon completion of partial backloading at the initial port. The ship is then remanded to the next RVN maritime port for continuation of quarantine surveillance and inspection. The MQI at the last port of call accomplishes the final inspection of the vessel and grants clearance

CONFIDENTIAL

AVHGC-DST

SUBJECT: Operational Report-Lessons Learned of Headquarters,
United States Army, Vietnam, Period Ending 31 January
1970, RCS CSFOR-65 (R2) (U)

by certification of the USPHS Quarantine Declaration and the cargo manifest. This system has proved successful and will be continued at all USARV maritime ports.

(3) Reduction of Civilian Personnel. During the 2d Quarter, FY 70, instructions were received from CINCUSARPAC providing revised End of Fiscal Year 70 strength ceilings for both DAC and ~~local-national~~ employment programs. These revisions in the ceiling reduced the DAC authorization 81 employees to 706 employees. The LN authorization was reduced 3,183 to 31,433 employees. In addition to reducing employment ceilings, these instructions required reduction in budgetary man year utilization - 40 DAC man years and 1,010 LN man years. The budgetary man year reductions required that the year end strength ceilings be placed in effect on 31 January 1970. Vouchers reflecting the new authorizations were issued to major subordinate commands during November and December.

c. (C) INTELLIGENCE.

(1) Significant Enemy Activities.

(a) General. During the quarter, enemy initiated activity generally was at a moderate level. The enemy apparently initiated his Winter-Spring Campaign, with the possible exception of I CTZ, during the period. He achieved a number of irregularly executed highpoints rather than succeeding in undertaking a coordinated country-wide general offensive. His activity was characterized, for the most part, by isolated attacks by fire, ground probes with sapper attacks and terrorist activity directed against the GVN pacification program. Particularly significant were the series of enemy ground and standoff attacks on Allied installations in the Bu Prang - Duc Lap area of II CTZ in November; the continuing harassment of Allied fire support bases in northern War Zone "C" of Tay Ninh Province and in Phuoc Long Province of III CTZ; and continued enemy attempts to infiltrate major maneuver elements from III CTZ to IV CTZ.

CONFIDENTIAL

CONFIDENTIAL

AVHGC-DST

SUBJECT: Operational Report-Lessons Learned of Headquarters,
United States Army, Vietnam, Period Ending 31 January
1970, RCS CSFOR-65 (R2) (U)

(b) I Corps Tactical Zone. Enemy initiated actions, in I Corps Tactical Zone, were predominantly undertaken by VC Local Force units. Major NVA maneuver elements remained elusive and out of contact, apparently engaging in logistical activity and preparing for the Winter-Spring Campaign. Allied operations in the Piedmont region during November resulted in uncovering large caches of rice. During December, the headquarters of the 3 NVA Division, along with its support units and the 2 VC Regiment moved from southern I CTZ to II CTZ. During January, elements of the division's third regiment (22 NVA Regiment) moved south towards the I - II CTZ boundary. The enemy again continued his attempts to disrupt the GVN pacification program by terrorist activities and attacking refugee camps throughout the Zone.

(c) II Corps Tactical Zone. Enemy initiated activity in II Corps Tactical Zone varied from a low to moderate level during the past three months. Activity was characterized by attacks by fire, sporadic ground and sapper attacks, interdiction of lines of communication (particularly QL 19) and terrorist activity. In November, the 28 and 66 NVA Regiments and the K-37 NVA Sapper Battalion, supported by artillery, conducted a series of attacks in the Bu Prang - Duc Lap area. Three friendly fire support bases in the area were evacuated in early November. However, enemy attempts to achieve a significant victory over ARVN forces were unsuccessful. The enemy forces around Bu Prang and Duc Lap apparently withdrew to the north in early December and have not been located. Two enemy sapper attacks at An Kho in November caused significant friendly losses in materiel and supply. In one attack, 19 helicopters were destroyed at Camp Radcliff and in another, approximately 200,000 gallons of POL were destroyed at a nearby POL tank farm. There were no enemy casualties. In late December, the 3 NVA Division Headquarters and the 2 VC Regiment moved to Binh Dinh Province from southern I CTZ. The 18 Regiment and the 95B NVA Regiment conducted and increased number of convoy ambushes and harassment along QL 19 in January. (Captured documents indicate the start of a period of widespread offensive activity in II CTZ in the latter half of January.)

6

CONFIDENTIAL

CONFIDENTIAL

AVHGC-DST

SUBJECT: Operational Report-Lessons Learned of Headquarters,
United States Army, Vietnam, Period Ending 31 January
1970, RCS CSFOR-65 (R2) (U)

(d) III Corps Tactical Zone. Enemy initiated activity in III Corps Tactical Zone increased noticeably during the period as the enemy evidently initiated the first phase of the Winter-Spring Campaign in early November. The period was further highlighted by the redeployment of two III CTZ regiments (88 and 101D Regiments) to IV CTZ. The enemy placed major emphasis on the fire support base belt in northern Tay Ninh Province and the Bu Dop - Bo Duc area of northern Phuoc Long Province. The enemy targeted these areas in an attempt to divert Allied operations from the interdiction of his fragile supply routes (the northern Tay Ninh diagonal infiltration route, Serges Jungle Highway, and Adam's Road). The success of Allied operations against these infiltration routes was evident in the discovery of a new major route, Jolley Road, located in mid-December. Jolley Road generally follows the II CTZ - III CTZ tactical boundary from Cambodia to the Dong Nai River, then turns westward following the Phuoc Long - Long Khanh provincial boundary to the vicinity of Rang Rang. Activity decreased slightly in early January as evidence grew of enemy preparations for increased offensive activity around the TET period. (Reports indicated that this activity would begin in late January.)

(e) IV Corps Tactical Zone. Enemy initiated activity in the IV Corps Tactical Zone remained at a low to moderate level. During early November and early December, there were marked increases in enemy activity. An expected increase in enemy activity early in January did not materialize until the middle of the month. Extensive friendly operations conducted during the reporting period have probably disrupted and delayed much of the enemy's planning for deploying his forces into an offensive posture. Of most significance during the period was the relocation of two additional regiments, both NVA, from III CTZ to IV CTZ. A prisoner captured in the 3 December attack against Long Khot identified his unit as the 2 Battalion, 88 NVA Regiment which is currently located in the Ba Thu area. Documents captured in Chau Doc Province, revealed the presence of the 101D NVA Regiment and possibly the 1 NVA Division Headquarters in the Seven Mountains area. Additional documents captured on 29 December revealed the possibility of the 101D NVA

CONFIDENTIAL

AVHGC-DST

SUBJECT: Operational Report-Lessons Learned of Headquarters,
United States Army, Vietnam, Period Ending 31 January
1970, RCS CSFOR-65 (R2) (U)

Regiment moving southwest of the Seven Mountains area to Ha Tieu and the 18B NVA Regiment relocating south to the Three Sisters area with a possible ultimate destination of the U-Minh Forest.

(2) Significant Intelligence Operational Activities. The following significant activities took place during the reporting period.

- | | |
|------------------|---|
| 1 November 1969 | Final edition of the Monthly Intelligence Review was published. |
| 20 November 1969 | A letter from the Acting Chief of Staff, HQ USARV, subject Operations Security (OPSEC), forwarded a CINCPAC OPSEC study, on the Enemy COMINT Threat to OPSEC in SVN, down to and including the company/battery echelon. |
| 23 November 1969 | Recent Sapper Activity and Current Indicators of the Future Actions Study published. |
| 7 December 1969 | Review of Recent Convoy Ambushes Study published. |
| 26 December 1969 | Military Intelligence Detachments reorganized in Corps/Field Force, Division and Separate Brigades. |
| 10 January 1970 | Third Quarter, FY 71, Combat Intelligence Lessons published. |
| 11 January 1970 | Resume of NVA/VC Sapper Tactics and Techniques published. |
| 18 January 1970 | The TET 68 Offensive, Post TET 69 Offensive and the Winter Spring Campaign 1969-70; Comparison and Projection Study published. |
| 20 January 1970 | Airborne Personnel Detector Pamphlet published. |

CONFIDENTIAL

AVHGC-DST

SUBJECT: Operational Report-Lessons Learned of Headquarters,
United States Army, Vietnam, Period Ending 31 January
1970, RCS CSFOR-65 (R2) (U)

31 January 1970 History of the 273d VC Regiment, July 1964
December 1969, published.

(3) A monthly intelligence briefing was conducted for all newly arrived and assigned officers and senior non-commissioned officers assigned duty with Headquarters, USARV. In addition, special intelligence briefings were given for visiting dignitaries as required.

(4) A weekly intelligence conference was held each Friday at 1330 hours. The agenda of the conference included summaries of the significant operations, enemy activity, and enemy order of battle updating. Weekly Intelligence Conference Notes were provided to all attendees including representatives from the local intelligence community and from the general and special staffs of HQ USARV.

(5) The Current Analysis Special Intelligence (CASI) Branch provided material to support a review of all-source intelligence which was presented to the Command Group and designated USARV staff members daily. In addition, the CASI Branch presented an all-source briefing each Saturday to the Commanding General, 1st Logistical Command, Commanding General, 1st Signal Brigade, and designated members of the USARV and subordinate staffs. Special briefings for the Deputy Commanding General, USARV, the Chief of Staff, and other members of the USARV staff were conducted as required.

(6) During November 1969, this headquarters commenced scheduling a NESTOR Demonstration Team at major subordinate commands. Purpose of the demonstration is to familiarize staff and operational personnel to the complete NESTOR family of equipment and to emphasize that the use of NESTOR equipment is the simplest and one of the most effective means available to counter the NVA/VC communications intercept threat existing within RVN. The display/demonstration is presented by personnel of the COMSEC Logistics Support Center, Long Binh. The presentation consists of a static display of all NESTOR equipment, and an operational demonstration of the PRC-77/KY-38.

CONFIDENTIAL

AVHGC-DST

SUBJECT: Operational Report-Lessons Learned of Headquarters,
United States Army, Vietnam, Period Ending 31 January
1970, RCS CSFOR-65 (R2) (U)

(7) During the period 31 December 1969 through 9 January 1970, this headquarters in coordination with MACJ22, scheduled the presentation of briefings at all major subordinate commands on the enemy exploitation of US tactical communications. The briefing relates information derived from the capture, on 20 December 1969, of an entire enemy communications intelligence team, intercept equipment, intercepted voice messages and operating instructions. It provides irrefutable evidence of how the disregard for communications discipline and the failure to use approved codes are being exploited by the enemy. In order to insure the widest dissemination of this information, COMSEC Radio Research units are also presenting this briefing to supported Army units throughout Vietnam.

(8) The 1st Military Intelligence Battalion (Aerial Reconnaissance Support) (MIBARS) continued to conduct in-country orientation courses to acquaint newly assigned Image Interpreter (11) and G2 Air personnel with interpretation and G2 Air problems peculiar to tactical operations in the Republic of Vietnam. The courses were presented monthly at the 1st MIBARS School in Saigon to approximately 90 students.

d. (C) PLANS, OPERATIONS AND TRAINING.

(1) The Redeployment of US Army Units from RVN.

(a) Phase II of reduction of forces in RVN, known as KEYSTONE CARDINAL, was completed 15 December 1969. The US Army portion of the increment consisted of 14,082 personnel spaces. Included were 14 active Army units and 10 reserve component units redeployed to CONUS for inactivation or demobilization, 38 units inactivated in RVN and 31 units and two accounts drawdown.

(b) The President announced Phase III of the reduction of forces in RVN on 15 December 1969. The US Army force level in RVN will be reduced by 29,443 manpower spaces through space authorization reductions, unit inactivations and unit redeployments.

CONFIDENTIAL

AVHGC-DST

SUBJECT: Operational Report-Lessons Learned of Headquarters,
United States Army, Vietnam, Period Ending 31 January
1970, RCS CSFOR-65 (R2) (U)

(c) The 1st Infantry Division will be reduced to a color guard detachment in RVN. The detachment, representing the 1st Inf Div minus the 3d Bde, will redeploy to Fort Riley, Kansas. The 3d Bde distinguishing flag, unit organizational colors, and guidons will be forwarded to USAREUR. The 24th Inf Div (M) will be inactivated NLT 1 May 70 and concurrently the 1st Inf Div will be reorganized as the 1st Inf Div (MECH) using assets currently assigned to the 24th Inf Div (M).

(d) The 3d Bde, 4th Inf Div will be reduced to a color guard detachment in RVN, and the detachment redeployed to Fort Lewis, Washington for appropriate inactivation ceremonies.

(e) Five other major units will be reduced to color guard detachments in RVN, and the detachments redeployed to Fort Lewis, Washington for appropriate inactivation ceremonies.

(f) In-country reductions and inactivations include:

1. Fifty-two units that are to be reduced by reorganization.
2. Forty-one nondivisional units to be inactivated in RVN.
3. USARV patient account which is to be reduced.

(g) Redeployments will be completed by 15 April 1970.

(2) Turnover of Base Camps. As a result of the transfer to RVN of increased responsibility for all aspects of the war in Vietnam and the reduction of US forces in RVN, planning for the closing and turnover of Dau Tieng, Lai Khe and Camp Enari was begun during the month of January and will continue in the subsequent months.

(3) Transfer of Facilities - Nha Trang Air Force Base. Following several months of preliminary meetings and negotiations between USARV and the 7th Air Force, final agreement was reached on 23 November 1969

//
CONFIDENTIAL

CONFIDENTIAL

AVHGC-DST

SUBJECT: Operational Report-Lessons Learned of Headquarters,
United States Army, Vietnam, Period Ending 31 January
1970, RCS CSFOR-65 (R2) (U)

to move Army units from the Long Van area to a portion of Nha Trang Air Force Base. The purpose of this move was to assist the RVNAF Improvement and Modernization (I&M) Program by making the Long Van area available to VNAF to establish an air training center. Several problem areas with regard to allocation of facilities were resolved during the negotiations, as well as the provision of facilities engineering support pending completion of a formal Inter-Service Support Agreement. The actual relocation began in mid-December for Army units, and was completed during the early part of January 1970. The VNAF training center began making desired modifications to the Long Van facilities immediately after the departure of the Army units.

(4) Deployment of the M551 Sheridan. During the quarter, Sheridans were issued to the following units: 1/1 Armored Cavalry Squadron, Americal Division - 18 each. USARV informed CINCUSARPAC that there was no requirement for the M551 to operate a vehicular mounted mine exploder but there was a continuing requirement for a vehicular means to detect and clear mines.

(5) Nighthawk. ACTIV provided a fact sheet which summarized the conclusions and recommendations of their evaluation of the Nighthawk system. The recommendations were:

(a) That the Nighthawk system be adopted for employment by US units throughout the Republic of Vietnam.

(b) The following BOI serves as a guide:

<u>TYPE UNIT</u>	<u>NUMBER OF SYSTEMS</u>
Infantry Division	4
Airmobile Division	8
Separate Brigade	1
Armored Cavalry Regiment	2
Separate Air Cavalry Squadron	3
Combat Aviation Group	2-5 (depending on mission requirement)

12

CONFIDENTIAL

CONFIDENTIAL

AVHGC-DST

SUBJECT: Operational Report-Lessons Learned of Headquarters,
United States Army, Vietnam, Period Ending 31 January
1970, RCS CSFOR-65 (R2) (U)

Authorization for 36 additional AN/VSS-3 searchlights was requested from ACSFOR. These searchlights will be given to units in I and II Corps to support Nighthawk.

(6) USCONARC Liaison Team Visit. During the period 14 through 28 January 1970, a USCONARC Liaison Team visited HQ USARV and subordinate commands. The team was composed of representatives from Headquarters USCONARC and selected Army Service Schools. The purpose of the visit was to determine through observation, conference and interview, the adequacy of USCONARC Service Schools and ATC training in preparing personnel for assignment to RVN.

(7) RVNAF OJT Program. A significant increase in RVNAF OJT occurred during the period. US units at all levels have initiated OJT training to teach and upgrade skills of the ARVN. The 1st Logistical Command's "Project Buddy" was the forerunner of our present RVNAF OJT program. With the added emphasis on the improvement and modernization program and redeployment of US units, the trend will continue upward. Some of the training programs are a result of tasking by MACV, while the majority are due to arrangements between local commanders and MACV advisors. These programs are well received and are proving highly beneficial for all concerned. Reports submitted by major commands to USARV show that 1,738 personnel have completed training and that 937 personnel are currently undergoing training. A USARV regulation has been approved for distribution. The regulation outlines procedures for conducting and reporting OJT.

(8) Sniper Program. Two of the six programmed sniper teams trained by the Army Marksmanship Training Unit arrived in RVN on 11 and 19 January 1970 and have been assigned to the 4th Inf Div and the 101st Abn Div (AM) respectively. The remaining teams are scheduled for deployment by the end of FY 70. A readjustment in the team requirement will be required by the redeployment of the 1st Inf Div.

CONFIDENTIAL

AVHGC-DST

SUBJECT: Operational Report-Lessons Learned of Headquarters,
United States Army, Vietnam, Period Ending 31 January
1970, RCS CSFOR-65 (R2) (U)

(9) NVA/VC Small Unit Tactics and Techniques Study, 1st Major Revision. The 1st major revision to the USARV NVA/VC Study, a comprehensive update and expansion of the original 22 March 1969 study, was approved for reproduction and distribution by the Chief of Staff on 5 December 1969. Distribution is expected to begin on 4 February 1970 and will be made to all agencies on the initial distribution list. The revised study provides information about the NVA/VC soldier, his tactics, communications, supply and medical procedures, political indoctrination, and various types of tactical unit and political organizational structure.

(10) Quick Reaction Lessons Learned (QRLL). Combat operations continued to be analyzed and material of value to tactical units was extracted and published in the form of Quick Reaction Lessons Learned. Eleven QRLLs were published and distributed during the reporting period. These were:

(a) Training Newsletters.

1. Training Newsletter Number 6-69 19 November 1969
Prevention of Skin Diseases of the Foot
and Boot Area
2. Training Newsletter Number 7-69 10 December 1969
Marking Helicopter Landing Sites

(b) Combat Lessons Bulletins.

1. Combat Lessons Bulletin Number 12 1 November 1969
Kit Carson Scout Operations

CONFIDENTIAL

AVHGC-DST

SUBJECT: Operational Report-Lessons Learned of Headquarters
United States Army, Vietnam, Period Ending 31 January
1970, RCS CSFOR-65 (R2) (U)

- | | |
|---|------------------|
| <u>2.</u> Combat Lessons Bulletin Number 13 | 17 November 1969 |
| Surveillance Task Force System | |
| <u>3.</u> Combat Lessons Bulletin Number 14 | 15 December 1969 |
| Taking the Night Away From Charlie | |
| <u>4.</u> Combat Lessons Bulletin Number 15 | 20 December 1969 |
| Sapper Operations | |
| <u>5.</u> Combat Lessons Bulletin Number 16 | 24 December 1969 |
| Air Delivered Munitions | |
| <u>6.</u> Combat Lessons Bulletin Number 17 | 27 December 1969 |
| Cache Finding Operations. | |
| (c) <u>Subject Letters.</u> | |
| <u>1.</u> Armor Operations in Vietnam | 23 November 1969 |
| <u>2.</u> Employment of Snipers | 6 December 1969 |
| (d) <u>Compilation of Lessons Learned.</u> | |
| Tips for Commanders | 11 January 1970 |

(11) ENSURE Program. ENSURE activities and events during the period 1 November 1969 to 31 January 1970 were:

(a) ENSURE 100: Iroquois Night Fighter and Night Tracker (INFANT). The INFANT system consists of a series of night vision image

CONFIDENTIAL

AVHGC-DST

**SUBJECT: Operational Report-Lessons Learned of Headquarters
United States Army, Vietnam, Period Ending 31 January
1970, RCS CSFOR-65 (R2) (U)**

intensifiers integrated with the weapons system for fire control, and mounted in the UH-1M helicopter. Three INFANT configured aircraft were received during the period for ACTIV evaluation. One was destroyed and is scheduled to be replaced.

(b) ENSURE 131.1: Boston Whaler: All deliveries have been completed for this ENSURE. A total of 485 Boston Whalers and 40 HP Johnson outboard motors have been provided. MACV advisor elements received 275 and USARV commands received 210.

(c) ENSURE 133: Air Cushion Vehicle (ACV). One of the three ACV's in the Army inventory was destroyed on 9 January 1970 after detonating what appeared to be a 500-pound dud bomb in the Plain of Reeds. The remaining two ACV's continue operations with the 3d Bde, 9th Inf Div.

(d) ENSURE 162.1: Armored Car. Final deliveries were received in December 1969. A total of 166 vehicles were provided for US, ROK, and RTAFV units.

(e) ENSURE 240: Sniper Rifles. Over 550 XM-21's (accrized national match M14 rifle with adjustable ranging telescope) arrived during the reporting period. The rifles are being distributed for issue through division sniper schools as the schools become operational.

(f) ENSURE 263: Multishot Portable Flame Weapon, XM 191: New Equipment Training (NET) and operational evaluation of the XM 191 commenced in October 1969. NET for USARV units will continue until February 1970 while the ACTIV evaluation will continue until April 1970. Three hundred launchers and 12,000 rounds of ammunition were received during the reporting period.

(g) ENSURE 272: Integrated Observation System (IOS). Four IOS's were delivered during the period for evaluation by ACTIV. An add-on ENSURE request was submitted for six more IOS's and is

CONFIDENTIAL

AVHGC-DST

SUBJECT: Operational Report- Lessons Learned of Headquarters
United States Army, Vietnam, Period Ending 31 January
1970, RCS CSFOR-65 (R2) (U)

pending validation by DA. The LOS consists of a laser range finder bore sighted with a NOD for night operations and a ten power ships binocular for day operations.

(h) ENSURE 318: Heavy Duty High Pressure Cleaning System-Water Blaster. The six water blasters in-country completed the ACTIV evaluation in November 1969. Fifteen additional systems have been requested to support retrograde operations. Deliveries are expected to commence approximately 1 February 1970.

(i) ENSURE 332: Replacement Radar for AN/TPS-25, RATAAC. A new ENSURE request was submitted to DA for this French/German developed radar system to be the follow-on to the AN/TPS-25. Thirty-one radars were requested. DA validated the requirement for 20 radars.

(j) ENSURE 333: Log Periodic Antenna, AS-2236. A new ENSURE request was submitted to DA for six AS-2236 Log Periodic Antennas for evaluation. The antenna is expected to permit direct secure voice communications at greater range than the standard AS-2169 currently authorized for Army divisions.

(k) ENSURE (unnumbered): Precision Para-Wing Aerial Delivery System (PPADS): A new ENSURE request for the PPADS was submitted in December 1969. The system is a 2000-pound cargo payload, radio controlled, delivery system to be employed by the 5th Special Forces Group. USARV requested 50 transmitters and 150 canopies. The request is pending validation by DA.

e. (C) LOGISTICS.

(1) Services Activities.

CONFIDENTIAL

AVHGC-DST

SUBJECT: Operational Report-Lessons Learned of Headquarters
United States Army, Vietnam, Period Ending 31 January
1970, RCS CSFOR-65 (R2) (U)

(a) Cargo discharged and handled in RVN ports (ST).

<u>Month</u>	<u>Discharged</u>	<u>Handled</u>
October	423, 307	600, 921
November	422, 247	580, 340
December	432, 813	594, 063

(b) Sea Land Container Service.

<u>Month</u>	<u>Dry vans</u>	<u>Reefer Vans</u>	<u>Total</u>
October	1, 884	360	2, 244
November	1, 435	239	1, 674
December	2, 085	575	2, 660

(c) Motor Transport Tonnage (ST).

<u>Month</u>	<u>Port and Beach</u>	<u>Local</u>	<u>Line</u>	<u>Total</u>
October	200, 345	241, 557	126, 304	568, 206
November	244, 936	237, 749	133, 141	615, 826
December	289, 980	188, 702	128, 903	607, 585
Total CY 69 Tonnage:		8, 216, 443		

CONFIDENTIAL

AVHGC-DST

SUBJECT: Operational Report-Lessons Learned of Headquarters,
United States Army, Vietnam, Period Ending 31 January
1970, RCS CSFOR-65 (R2) (U)

<u>Month</u>	<u>Vans</u>	<u>S&P's</u>
October	19	243
November	78	331
December	25	187

(e) Rail Tonnage (ST). During CY 69, a total of 617,342.6 ST of cargo was moved, making the CY 69 the second highest year since 1955 for cargo in RVN. (In 1967, a total of 680,000 ST of cargo was moved--much of which was rock for Phu Cat and Tuy Hoa Air Force Bases.) Rail tonnages for the past quarter are as follows:

<u>Month</u>	<u>US Military Sponsored</u>	<u>Non US Military Sponsored</u>
October	56,139.0	1,574.2
November	50,881.6	2,282.5
December	47,789.0	15,450.0

(f) Rail Passengers. During CY 69, 2,220,971 passengers were moved by rail. While only a little more than half as many passengers as were moved in 1956 and 1957 (approximately 4.2 million each year), CY 69 was the biggest passenger year since 1961. Passenger figures for the past quarter are as follows:

<u>Month</u>	<u>US Military Sponsored</u>	<u>Non US Military Sponsored</u>
October	219,954	4,239
November	219,856	6,819
December	238,543	9,559

CONFIDENTIAL

AVHGC-DST

SUBJECT: Operational Report-Lessons Learned of Headquarters,
United States Army, Vietnam, Period Ending 31 January
1970, RCS CSFOR-65 (R2) (U)

(g) Major Rail Accomplishments of CY 69.

1. On the Saigon Division, the M&M Spur and RMK (Thu Duc) Island spurs were opened in February. In May and June, passenger service was initiated between Saigon, Thu Duc, Thu Duc Island, Di An, Bien Hoa, and Long Binh (Ho Nai). By the end of December, the Saigon line had moved 922, 513 passengers; economically benefiting the villages along the rail line, saving the US Army a considerable sum of money, reducing traffic between Saigon and Long Binh, expanding the overall operational capability of the VNRS and aiding local internal development. At Ho Nai (North Long Binh), a new passenger check point was established as were security cargo holding yards.

2. On the Nha Trang Division, reefer cargo was first shipped in the Qui Nhon-Tuy Hoa area as the VNRS and 2d Military Railway Security (MRS) Battalion tightened up cargo security procedures in a joint effort to reduce pilferage.

3. On the Da Nang Division, the Da Nang-Hue section of the railroad was opened in early February and in May, reconstruction work commenced north of Hue towards Dong Ha. During the year, five of the ten major bridges north of Hue were rebuilt jointly by the VNRS and the Scebess, and three spurs were completed at Phu Bai, Camp Haskins, and Da Nang.

(h) Air Passenger Movements (Out-of-Country).

<u>Month</u>	<u>Programed</u>	<u>Allocated</u>	<u>Actually Moved</u>	<u>% Allocated Moved</u>
October	33,356	35,283	34,485	97.5
November	20,215	30,850	32,018	104.8
December	41,693	43,649	43,491	99.6

CONFIDENTIAL

AVHGC-DST

SUBJECT: Operational Report-Lessons Learned of Headquarters,
United States Army, Vietnam, Period Ending 31 January
1970, RGS CSFOR-65 (R2). (U)

(i) Intra-RVN Cargo/Passenger Movements.

<u>Month</u>	<u>Cargo</u>	<u>Passengers</u>
October	43,903	150,715
November	45,719	157,706
December	50,329	159,357

(j) Emergency Airlift Shipments.

<u>Month</u>	<u>Tactical Emergency</u>	<u>Emergency Resupply</u>	<u>Combat Essential</u>	<u>Total</u>
October	2	4	47	53
November	1	4	106	111
December	0	4	76	80

(k) Seat Utilization. Since 8 June 1969, redeployments have had a tremendous effect on personnel deploying via normal channel airlift. Despite the problems, USARV has managed to maintain excellent seat utilization during the last three months. Seat utilization for the past quarter is as follows and includes all traffic on all channels from RVN to CONUS:

<u>Month</u>	<u>Seats Programed</u>	<u>Seats Allocated</u>	<u>Personnel Moved</u>	<u>% Filled</u>
October	32,108	32,652	33,435	102.0
November	28,075	27,613	28,807	105.1
December	41,695	41,222	41,064	99.7

CONFIDENTIAL

AVHGC-DST

**SUBJECT: Operational Report-Lessons Learned of Headquarters,
United States Army, Vietnam, Period Ending 31 January
1970, RCS CSFOR-65 (R2) (U)**

(2) Graves Registration Operations. Summary of mortuary operations is as follows:

(a) Remains processed.

<u>Month</u>	<u>USA Mortuary, TSN</u>	<u>USA Mortuary, DNG</u>	<u>Total</u>
October	344	221	565
November	452	180	632
December	361	198	559

(b) Personal Property Depot Status.

Cases on hand 1 Oct 69	365
Cases received 1 Oct - 31 Dec 69	1,380
Cases shipped 1 Oct - 31 Dec 69	1,475
Cases on hand 31 Dec 69	270

(3) Class III Supply and Distribution. Consumption of bulk petroleum by US Forces, FWMAF, and RVNAF in II, III, and IV CTZ, and Army in I CTZ during the quarter was as follows:

October	2,603,900 Bbl
November	2,527,800 Bbl
December	2,697,400 Bbl

(4) Property Disposal Operations.

CONFIDENTIAL

AVHGC-DST

SUBJECT: Operational Report- Lessons Learned of Headquarters.
United States Army, Vietnam, Period Ending 31 January
1970, RCS CSFOR-65 (R2) (U)

(a) Summary of PDO Operations.

<u>Month</u>	<u>Proceeds</u>	<u>ST's</u>
October	\$ 392,429	7,313.9
November	155,009	2,659.9
December	354,624	10,014.0

(b) MAPEX Transfers.

<u>Month</u>	<u>Dollar Value</u>	<u>ST's</u>
October	\$ 796,410	693.72
November	1,640,452	1,369.56
December	1,300,248	739.49

(5) Command Maintenance Management Inspection (CMMI) Program.
During 2d Quarter, FY 70, 399 CMMI's were conducted in USARV with 132 units (33%) receiving an unsatisfactory rating. The standards used for USARV CMMI's are those listed in DA Pamphlet 750-10, Command Maintenance Management Inspection Handbook, 24 January 1969.

(a) Vehicle Spot Check Inspections. Increased emphasis has been placed on vehicle spot check inspections and during the quarter 1,270 vehicles were inspected by USARV teams. In addition to these inspections, each major subordinate command has implemented spot inspection programs. An 11 percent improvement in vehicle serviceability was noted during the quarter. This improvement can be indirectly attributed to the 35 percent increase in inspections and added command emphasis. Of the 1,270 vehicles inspected by USARV teams, 753 (59%) received an unsatisfactory rating. Since the majority of the

CONFIDENTIAL

AVHIGC-DST

SUBJECT: Operational Report- Lessons Learned of Headquarters,
United States Army, Vietnam, Period Ending 31 January
1970, RCS CSFOR-65 (R2) (U)

units in Vietnam retain the vehicle log books in the dispatch offices, the failure rate represents the actual condition of the vehicles and does not take into consideration repair parts on requisition nor maintenance deferred until the next scheduled services.

(b) Vehicle Utilization and Control. In combat areas, strict accountability is reduced through necessity, and as stability becomes a reality, recovery of excesses becomes paramount. To reduce the need for new theater assets and to gain maximum utilization of vehicular assets, the command initiated a positive vehicle utilization and control program. "No questions asked" turn-in points were established, military police patrols were designated to verify ownership of vehicles, requisition procedures for major items were strengthened and regulations were published requiring more strict control of assets. During 2d Quarter FY 70, military police patrols recovered vehicles valued at 1.6 million dollars indicating the success with which assets are being recovered.

(6) The Repair and Return Program For Communications-Electronics Equipment. As a result of increased inputs of repairables from Vietnam and budget cuts in CONUS, the R&R Program encountered serious difficulty during the Oct-Dec 69 time frame. In order to improve the R&R Program performance, USARV has:

(a) Designated specific DS/GS units authorized to evacuate R&R items.

(b) Deleted items from the R&R Program which can be supported through the supply system or maintained in-country.

(c) Initiated new follow-up procedures for RVN DS/GS units to insure receipt in CONUS of items evacuated on R&R.

(d) Limited evacuation of R&R items to those authorized in USAECOM Supply Information Letter 9-69 and subsequent revision.

CONFIDENTIAL

AVHGC-DST

SUBJECT: Operational Report-Lessons Learned of Headquarters,
United States Army, Vietnam, Period Ending 31 January
1970, RCS CSFOR-65 (R2) (U)

The above recent refinements in the R&R program constitute significant changes in procedures employed in the program. These refinements are in the process of being evaluated and should indicate some improvement in the program.

(7) (U) M16 Rifle Management. In early 1968, this Command experienced considerable malfunctions of the M16 rifle. In May 1968, USAMC Project Manager, Rifles, established a special M16 Field Office with three field grade officers and one senior NCO, all of whom were specialized in the small arms field. The intensive management of the M16 problem resulted in the reduction of malfunctions as shown below:

	<u>May 68</u>	<u>Nov 69</u>
Density of Weapons	153, 509	261, 261
Malfunctions per 1000 Weapons	3.247	.323

Due to the greatly reduced magnitude of the M16 problem, the Project Manager's office was inactivated on 1 Nov 69, and all activities and functions were absorbed by the USARV G4.

(8) Ammunition Supply.

(a) Four ammunition items were under Available Supply Rate (ASR) allocation management at the end of January 1970 as compared to seven at the end of October 1969. Items under ASR allocation management at the close of the period were:

*Ctg 40mm HE, B572	*Sig Illum WSP, L312
*Ctg 152mm HE-T, D592	*Sig Illum GSC, L314

*Items under DA ASR management.

CONFIDENTIAL

AVHGC-DST

**SUBJECT: Operational Report-Lessons Learned of Headquarters,
United States Army, Vietnam, Period Ending 31 January
1970, RCS CSFOR-65 (R2) (U)**

(b) Phase IV of the retrograde program was completed in December. A total of 10,767 ST were retrograded under Phase IV.

(c) Average Class V receipts over this period were more than the average issues (96,035 ST vs 77,802 ST).

(d) Bad weather causing large sea swells resulted in ammunition unloading at Qui Nhon to be modified in November. Waivers were obtained for discharge of Class V at the DeLong Pier. General cargo receipts were such that when the Class V was diverted to the DeLong Pier there was little or no impact. During the period there were shortages of some items in the Da Nang Support Command, because shipments into that command were disrupted by the inclement weather. Harbor discharge operations were severely curtailed because of high seas resulting in the diversion of two ammunition ships to Cam Ranh Bay and one to Qui Nhon. Bad weather influenced off loadings at Qui Nhon also. Qui Nhon lost 1775.5 hours in the discharge of ammunition ships during Nov - Dec, due to high seas. Weather conditions and high seas, experienced recently, are considered unusual by personnel of the Da Nang Support Command. In past years, time has been lost due to high seas during the monsoon season but never for such extended periods. The monsoon is at a diminishing stage and no extensive future delays are anticipated.

(e) Suspension of the D381, 152mm HEAT-T, caused problems in USARV. USARV was required to airlift, on short notice, some 6,000+ substitute rounds, D592, 152mm HE-T to satisfy immediate requirements. Additionally, USARV was required to recall to the ASP's all D381 rounds suspended and impose strict ASR management on the available D592 rounds. The suspension of the D381 round was lifted in mid-January, thereby relieving the situation.

(f) Americal Div investigated the regular digging by Vietnamese in the Vicinity of Duc Pho whereupon an old ASP, which had blown several years ago, was discovered. Americal Div undertook the task of

CONFIDENTIAL

AVHGC-DST

SUBJECT: Operational Report-Lessons Learned of Headquarters,
United States Army, Vietnam, Period Ending 31 January
1970, RCS CSFOR-65 (R2) (U)

security and clearance of the area in order to deny further munitions to the enemy. Coordination has been effected between EOD and engineers in an effort to clear the area--considerable earth movement is required to get deep enough to recover, for disposal, those munitions buried by the blow and time.

(g) Comprehensive reviews of available repship information coupled with extensive follow-up and coordination with transportation agencies by USARV caused the system to respond more favorably in November and December. The foregoing was brought about by ammunition shipments arriving well after the required delivery date (RDD). In some cases, the RDD was missed by more than 30 days.

(h) Although the number of artillery and mortar tubes available to USARV decreased with the impact of KEYSTONE EAGLE and KEYSTONE CARDINAL, a corresponding lowering in ammunition usage cannot be expected. Firing units remaining are required to increase their rate of fire to compensate for the loss of redeployed units. This fact is apparently in conflict with DA theory that as troops withdraw ammunition consumption decreases in a straight line relationship. This is simply not the case in RVN where the war is fought from hundreds of island type bases instead of from within conventional Army, Corps, Division, etc. boundaries. Tubes remaining after troop withdrawals still have the entire area to cover and the only way to cover it is with more fire from fewer tubes. Heavy expenditures of artillery and mortar ammunition has prevented the enemy from massing to launch a significant attack, keeps him engaged at long range with the end result being the saving of lives.

(i) The USARV offshore reserve was recently required to provide significant quantities of munitions in order to sustain ground combat in RVN. Use of the offshore reserve is an established "way of life" and without it USARV would be in considerable difficulty when the issues appreciably exceed the receipts for two or more months in succession.

CONFIDENTIAL

AVHGC-DST

**SUBJECT: Operational Report - Lessons Learned of Headquarters,
United States Army, Vietnam, Period Ending 31 January
1970, RCS CSFOR-65 (R2) (U)**

f. (U) COMMAND MANAGEMENT: Destruction of Series 661 MPC.

(1) Subsequent to Conversion Day (C-Day), 11 August 1969, plans were developed by this headquarters to decentralize the destruction of invalidated Series 661 MPC to division, separate brigade, and support command level.

(2) The centralized destruction of MPC after the first C-Day, 21 October 1968, resulted in complete disruption of the Funding Division, US Army Central Finance and Accounting Office, Vietnam for approximately five months. This headquarters recommended the decentralized destruction concept to the Comptroller of the Army in order to minimize security hazards, decrease transportation costs, alleviate the disruption of the Funding Division, reduce the time required to destroy the MPC to a minimum, and provide for a more equal distribution of workload and experience. The Comptroller of the Army authorized the decentralized destruction of Series 661 MPC as an exception to AR 37-103 on 4 October 1969.

(3) The reconciliation of Series 661 MPC was completed and submitted to Comptroller of the Army on 25 November 1969 for approval. Approval was received on 5 December and the decentralized destruction began on 10 December 1969. Detailed policies and procedures to be used during the destruction of the invalidated MPC were provided by this headquarters. The actual destruction was accomplished by burning. Total destruction of approximately \$285,000,000 in MPC was completed by 15 January 1970.

(4) The decentralized destruction concept was considered a complete success with a minimum of problems experienced. An after action report is being prepared for submission to the Comptroller of the Army requesting a change in the invalidated MPC destruction procedures prescribed in AR 37-103.

CONFIDENTIAL

AVHGC DST

SUBJECT: Operational Report-Lessons Learned of Headquarters,
United States Army, Vietnam, Period Ending 31 January
1970, RGS CSFOR-65 (R2) (U)

g. (U) INSPECTOR GENERAL.

(1) During the period, 425 complaints and 1,845 requests for assistance were processed. Of the 425 complaints received, 121 (or 29%) were determined to be justified. The total number of complaints received represents a considerable increase over the previous quarter. This increase can be attributed, in part, to an increased vocalism through IG channels. There is an apparent reluctance on the part of enlisted men to use the normal chain of command, i. e., first sergeant and commanding officer, since many complainants are writing directly to the President, members of Congress, and other government officials without first making the grievance known to the unit commander. The largest group of complaints were again in the areas of unit administration, alleging improper handling of disciplinary matters and undue harassment. A relatively small number, 26 (6% of the total received), alleged racial discrimination. Of these, none were found to be substantiated. Overall, there was no indication of problem areas or trends which could result in conditions detrimental to the efficiency or reputation of the command.

(2) HQ USARV conducted annual general inspections of 34 USARV organizations during the period. Areas most often found to be unsatisfactory or deficient were: Failing to publish directives outlining the commander's plaster expenditure reduction program or not specifying the 10 dollars per man per month voluntary goal; making expenditures from the unit fund prior to council approval; failing to establish incentive awards programs to recognize unit and individual accomplishments in fields related to logistic readiness; citing the wrong authority on unit orders announcing assumption of command; failing to include all elements of the transaction code in unit orders; failing to establish controls to insure that morning report entries were made on EDCSA and other effective dates; failing to appoint primary censorship officers on the basis of one for each 100 personnel assigned or attached; failing to include a requirement for semi-annual familiarization firing and chemical warfare training in training programs; and

CONFIDENTIAL

AVHCC-D3T

SUBJECT: Operational Report-Lessons Learned of Headquarters,
United States Army, Vietnam, Period Ending 31 January
1970, RCS CSFOR-65 (R2) (U)

failing to establish property book accountability for items of organizational clothing and equipment. Common deficiencies noted in the areas of maintenance management and maintenance of tactical equipment were: failing to establish on-the-job training programs for maintenance personnel; failing to establish preventive maintenance schedules for small items of engineer equipment (generators, chain saws, compressors, etc); erroneously assigning issue priority designators 02 and 05 to requisitions for repair parts not essential for mission accomplishment, and failing to provide for proper operator maintenance.

h. (U) COMMAND INFORMATION. None.

i. (U) CIVIL AFFAIRS.

Three civil affairs publications were prepared during the reporting period and forwarded to USARPAC on 26 January 1970. These were: Civil Affairs Estimate; Civil Affairs Handbook; and an Area Study for RVN.

j. (U) COMMAND HISTORY.

(1) Organization. A request was submitted to withhold an MHD from Phase III Redeployment. The request was approved and the MHD, when it becomes available, will work with the USARV Command Historian to provide historical coverage of the advisory effort in III CTZ.

(2) Historical Activities. Emphasis continued to be placed upon recording historical action and events throughout RVN. The 13th MHD, 21st MHD, and 45th MHD collaborated in collecting material and taping interviews concerning the action in the Duc Lap-Bu Long area in November.

k. (C) AVIATION.

CONFIDENTIAL

AVHGC-DST

SUBJECT: Operational Report-Lessons Learned of Headquarters,
United States Army, Vietnam, Period Ending 31 January
1970, RCS CSF OR-65 (R2) (U)

(1) Air Operations.

(a) Joint Air Operations Group (JAOG). The fourth quarterly meeting of the MACV JAOG was held on 12 January 1970. The results of this meeting were:

1. The meeting was chaired by BG John H. Herring, Jr., Commander, 834th Air Division, representing the Commander, 7th Air Force. At the conclusion of the meeting, chairmanship was transferred to BG George W. Putnam, Jr., representing the Deputy Commanding General, USARV. BG Putnam is the chairman of the JAOG for third quarter FY 70.

2. Actions of the JAOG working groups are of continuing nature and no major changes in the exercise of air operations were presented for consideration by the JAOG.

3. VNAF representation as a member of the JAOG was proposed and accepted by the JAOG. Action to solicit VNAF representation will be forwarded through MACV and RVNAF Joint General Staff.

(b) Dedicated C-7A Aircraft Support. A study was conducted to determine the adequacy of present dedicated C-7A aircraft support rendered USARV units and to establish requirements for this type of support. The results are based on replies to a questionnaire submitted to major field commanders. The conclusions are that dedicated C-7A aircraft support is responsive to the assigned users; however, the level of support is not adequate to meet requirements. The study determined that approximately two additional squadrons of dedicated C-7A or follow-on STOL aircraft are needed to meet USARV requirements. This study was forwarded to MACV for use as input for the on-going review of dedicated airlift requirements being conducted by the Joint Army and Air Force New Focus Inter-Service Coordinating Teams. A copy was also furnished the CDC Aviation Agency for use in the STOL Utility Fixed Wing Aircraft Study presently being conducted.

CONFIDENTIAL

AVHGC-DST

SUBJECT: Operational Report-Lessons Learned of Headquarters,
United States Army, Vietnam, Period Ending 31 January
1970. RCS CSFOR-65 (RZ) (U)

(2) Aviation Training.

(a) AH-1G: During the reporting period, the AH-1G training team transitioned 80 aviators, graduated 16 aviators from the two Instructor Pilot/Standardization Instructor Pilot (IP/SIP) courses conducted, and qualified 11 additional aviators as IP/SIP's during non-school training time.

(b) OH-6A: The Program of Instruction (POI) for the OH-6A Transition and Instructor Pilot courses was revised to increase the output of transition students. Forty-two students were transitioned and 40 instructor pilots and 12 standardization instructor pilots were trained.

(c) OH-58A: The New Equipment Training Team (NETT) transitioned 64 aviators and trained 104 maintenance personnel. On 11 January 1970, the transition course was reduced from 11 days to 7 days resulting in a greater student output and a reduction in the time an aviator is required to be away from his unit.

(d) T-55-1-11 Engine NETT: Seven maintenance personnel were trained before the NETT contract for the T-55-1-11 Engine expired 15 November 1969.

(e) CH-47C SAS & Speed Trim NETT: The NETT arrived in RVN 17 January 1970 and began training on 26 January 1970. Eight maintenance personnel were trained.

(f) The Army Aviation Refresher Training School (AARTS) continued to operate at maximum capacity. A total of 831 personnel were graduated during the reporting period.

(3) Logistics.

(a) The scheduled transfer of 15 UH-1H aircraft from USARV to VNAF was completed 18 January 1970. MACV directed that an

CONFIDENTIAL

AVHGC-DST

SUBJECT: Operational Report-Lessons Learned of Headquarters,
United States Army, Vietnam, Period Ending 31 January
1970, RGS CSFOR-65 (RZ) (U)

additional nine UH-1H aircraft be issued to the VNAF as advanced attrition replacement aircraft. This action was completed on 7 January 1970. The nine advanced attrition aircraft will provide the VNAF a temporary maintenance float until the VNAF helicopter fleet expands.

(b) Aircraft Armament:

1. The first six XM-35 armament subsystems (20mm automatic gun) were received in RVN during December 1969. Initial functional firing tests were conducted 7 January 1970 and new equipment training is in progress.

2. Ninety XM-59 armament subsystems (.50 Cal MG) were received in December 1969. Mounting trials disclosed that 33 pintle post assemblies were not compatible with the dimensions of the base mount tube assembly. Six were correctable in-country and 27 were returned to CONUS.

3. Evaluation of the Nighthawk system (incorporating the XM-27E1 armament subsystem as a pintle mounted minigun, a Xenon searchlight and a night observation device) has been completed and a BOI developed establishing a requirement for 64 systems. DA has been requested to provide XM-93 (pintle mounted minigun) subsystems as a standard replacement for the XM-27E1 in this usage.

4. A USARV aircraft armament inventory survey has been completed and asset reconciliation and redistribution is in progress.

(c) Avionics: An EIR has been submitted requesting the redesign or relocation of the AN/URC-68 (survival radio) on-off switch. Units reported the tendency of the batteries to fail quickly which may be due to inadvertent activation of the on-off switch. A field "fix" of placing a small piece of tape over the switch has been disseminated.

CONFIDENTIAL

AVHGC-DST

SUBJECT: Operational Report-Lessons Learned of Headquarters,
United States Army, Vietnam, Period Ending 31 January
1970, RCS GMPOR-55 (R2 0)

(4) Aviation Safety: USARV Supplement 1 to AR 95-5 has been published implementing the transfer of responsibility for issuing RVN control numbers for aircraft parts analysis from USARV Aviation Safety Division to the 34th General Support Group. This action should improve the accident/incident parts analysis program by permitting units to deal directly with the agency that processes requests.

1. (FOUO) ENGINEER.

(1) Operations.

(a) The 70th Engineer Battalion (Combat) was deployed from Ban Me Thuot to CONUS and inactivated.

(b) The 554th Engineer Battalion (Construction) was deployed from Cu Chi to Lai Khe to assume responsibility for construction of QL-13.

(c) The 544th Engineer Company (Construction Support) was deployed from Nui Ba Den to Gia Kiem to operate the industrial site at that location.

(d) The 513th Engineer Company (Dump Truck) was deployed from Khanh Duong to Phan Rang to provide haul capability in that area.

(e) The 523d Engineer Company, (Port Construction) was deployed from Vung Tau to Binh Thuy as a result of the plan to reduce the presence of US military elements at Vung Tau.

(f) In order to accommodate directed manning cuts, the 100th Engineer Company (Float Bridge) and the 500th Engineer Company (Panel Bridge) were combined as a provisional float and panel bridge company.

AVHGC-DST

SUBJECT: Operational Report-Lessons Learned of Headquarters,
United States Army, Vietnam, Period Ending 31 January
1970, RCS CSFOR-65 (R2) (U)

(2) USARV Engineer Reorganization.

(a) USARV has been considering ways to reduce the number and strengths of headquarters elements since troop unit redeployments were initiated in the 1st Quarter FY 70. An initial step was taken to reduce USARV headquarters by 134 military spaces in Phase II, an overall reduction of approximately 10 percent. Of these, 23 spaces were taken from the USARV Engineer Section. The diagram at inclosure 1 shows the organization of the USARV Engineer Section.

(b) In October 1969, the Chief of Staff directed the USARV Engineer to study the feasibility of consolidating and/or realigning the engineering functions now being performed by the HQ USARV staff, USAECAV and the 18th and 20th Engineer Brigades, which are:

1. The USARV Engineer Section advises the DCG, USARV and his staff on engineer matters and assures proper utilization of Army engineer resources through planning, coordination, and supervision.

2. The US Army Engineer Construction Agency Vietnam (USAECAV) is charged with the management and execution of the USARV facilities engineer and real estate programs. It also manages the MCA and LOC construction programs. The diagram at inclosure 2 shows the organization of USAECAV.

3. The two engineer brigades are TOE organizations responsible for directing the execution of engineer combat/operational support and programmed construction missions. Their functions are independent of those performed by the USARV Engineer Section and USAECAV. The number of brigade headquarters, required for command and control purposes, is related to the characteristics of the terrain and the major combat forces supported, as well as the size of the nondivisional engineer force structure.

AVHGC-DST

SUBJECT: Operational Report-Lessons Learned of Headquarters,
United States Army, Vietnam, Period Ending 31 January
1970. RGS CSFOR-65 (R2) (U)

(c) During October 1969, the USARV Engineer conducted an extensive study of existing and projected future engineer missions and functions, together with a number of organizational alternatives, in response to the Chief of Staff's guidance.

1. Part of the study concerned the reduction of engineer brigade and group headquarters as troop strengths and the scale of operations are reduced. The need for these command and control elements was shown to be related directly to the number of engineer battalions and separate companies in the active USARV force structure. The study recommended that the present structure of engineer group and brigade headquarters be changed only concurrently with the future redeployment of engineer battalions as follows:

a. Redeploy one of the six engineer group headquarters during the next phase.

b. Redeploy a second group headquarters after the total number of engineer battalions to be controlled is reduced below twenty.

c. Redeploy one engineer brigade headquarters after the total number of group headquarters is reduced to four and the total number of engineer battalions is less than twenty.

2. Part II of the study concerned consolidation of the engineer staff and management functions performed by the USARV Engineer Section and by USAECAV. It was concluded that consolidation was both feasible and desirable because:

a. Overlap of functions exists in certain areas.

b. The headquarters of USAECAV and the USARV Engineer Section are collocated at Long Binh.

c. The reduction of manpower resources in the USARV Engineer Section necessitated some internal reorganization.

AVHGC-DST

SUBJECT: Operational Report Lessons Learned of Headquarters,
United States Army, Vietnam, Period Ending 31 January
1970, RCS CSFOR-65 (R2) (U)

d. An overall personnel savings of approximating 15 per cent would be possible through consolidation.

(d) The USARV Engineer Organization Study was forwarded to the ACofS, Comptroller on 1 November 1969, recommending prompt action to organize the US Army Engineer Command, Vietnam (Provisional), (USAECV) (P), with the dual mission of performing the current functions of both the USARV Engineer Section and USAECAV. The diagram at inclosure 3 shows the organization of USAECV.

(e) The Chief of Staff approved the USARV Engineer Organization Study on 8 January 1970.

(f) Action was taken to organize USAECV (P) effective 1 February 1970. When added to the reduction already experienced by the USARV Engineer Section, the overall personnel savings through consolidation 17.1 percent.

(3) Airmobile Engineer Equipment. In order to provide relief for the critical USARV airmobile engineer equipment shortages, DA initiated special procurement of selected major items of equipment. This equipment is expected to become available during May 1970. USARV requested that the airmobile backhoe be added to the list of items selected for procurement which are airmobile compactors, graders, bulldozers, and scoop loaders. As an interim measure, USARV is redistributing the limited quantities of airmobile engineer equipment assets in equipment pools to the airmobile units in order to sustain operational capability.

(4) ARVN Land Clearing Organization. ARVN has scheduled three land clearing companies for activation. One company is presently undergoing training and the other two companies will be trained at a later date. Equipment for these units will be provided by transfer from US land clearing companies and the US company will be inactivated following transfer. All training will be provided by the 62d Engineer Battalion (Land Clearing) (Provisional).

AVHGC-DST

SUBJECT: Operational Report-Lessons Learned of Headquarters,
United States Army, Vietnam, Period Ending 31 January
1970, RCS CSFOR-65 (R2) (U)

(5) Mapping and Intelligence.

(a) Mapping projects continue to receive maximum effort with emphasis being placed on map revision and photomosaic production. Significant progress is being made in increasing the participation of GVN National Geographic Directorate (NGD) in the mapping activities.

(b) The engineer terrain intelligence activities have been terminated in I CTZ as the field office of the 579th Engineer Detachment located at Phu Bai was closed.

(c) The Hydrographic Survey Team continues to be engaged in reconnaissance of waterways south of Saigon.

(5) Supply.

(a) To date, all 123 items of the supplemental LOC-MCA equipment purchase have been shipped from CONUS and 107 have been received and issued.

(b) Equipment transfers to one ARVN construction battalion and one ARVN heavy equipment company are progressing on schedule. To date, 53 percent of the equipment for the construction battalion and 84 percent of the equipment for the heavy equipment company has been transferred.

m. (U) COMMUNICATIONS AND ELECTRONICS.

(1) Automated Telecommunications Center. During the quarter, USARV developed the necessary documentation for the automation of the USARV Communication Center as directed by the DOD plan of communications economy for writer to reader record communications. The automation of the USARV Communication Center will provide a basic message processing system allowing for expansion to full automation at a later date. The necessary documentation was submitted

CONFIDENTIAL

AVHGC-DST

SUBJECT: Operational Report-Lessons Learned of Headquarters,
United States Army, Vietnam, Period Ending 31 January
1970, RCS CSFOR-65 (R2) (U)

to USARPAC in January 1970 for the development of a subsystem
project plan and inclusion in the FY 72 program.

(2) USARV C-E LOI-1. On 30 December 1969, a new USARV
C-E LOI-1, Integrated AUTODIN/Teletype Network, was published
and distributed throughout the command for implementation. LOI-1
reconfigures the common user network and eliminates the dual role
where some tributary communication centers were also functioning
as teletype relays. LOI-1 also allows the number of relays to be
reduced from eight to six. LOI-1 implementation to date is
approximately 25 percent.

2. (C) Lessons Learned: Commander's Observations, Evaluations,
and Recommendations.

a. (U) PERSONNEL: Forecasting Special Leaves.

(1) OBSERVATION: Commands had difficulty in forecasting
personnel desiring to take special leave during the month of December.

(2) EVALUATION: The regulation allows personnel who extend
in RVN to take leave to a destination of their choice utilizing space
required transportation. The majority of special leaves taken during
December are to CONUS for the Christmas holidays. Because of the
difficulties experienced during December 1968, commands were
requested to provide the USARV AG with the number of special leaves
forecasted to CONUS for the month of December as of 5 December 1969.
Approximately 6,000 were reported by the Army commands. The
number of special leaves moved by 31 December totaled 8,597, an
increase of 2,597 over and above those reported. Space required
personnel must be forecasted in advance in order that transportation
can be provided. The influx of unprogramed special leaves caused
a build-up in the replacement battalions while additional airlift was
being procured.

CONFIDENTIAL

AVHGC-DST

**SUBJECT: Operational Report-Lessons Learned of Headquarters,
United States Army, Vietnam, Period Ending 31 January
1970. RGS CSFOR-65 (R2) (U)**

(3) **RECOMMENDATION:** No action by higher headquarters required. Action within the command is for personnel desiring special leave during the Holiday Season (December) to initiate the action prior to 1 December each year. This will provide some reaction time to adjust airlift to handle the increase in passenger requirements. Only unusual or exceptional cases will be permitted to take special leave during December after the cut off date.

b. (C) INTELLIGENCE.

(1) Removal of the MMQ-2 Vans from SEA.

(a) **OBSERVATION:** The Manual Meteorological Station (MMQ-2 Van) was deployed to 16 locations throughout RVN. In its present configuration, the MMQ-2 Van has proved to be less than an ideal observing shelter for supporting the Army in a combat situation in this environment. Many problems have been encountered in using the van. The internal generator, the air conditioning unit, and the sophisticated meteorological sensors are one-of-a-kind items and are not compatible with other pieces of equipment in the inventory. The vans were introduced into the theater lacking spare parts, applicable technical orders, and inadequate maintenance technicians. One by one the vans or component parts failed and were unrepairable in RVN. When the internal generators failed and base power was available, the vans were tied into base power but the voltage fluctuations in power that is normal at outlying installations created situations that were incompatible with and caused serious damage to the sensitive meteorological sensors.

(b) **EVALUATION:** The MMQ-2 Vans and their associated components introduced unneeded sophistication to the weather support for the US Army, Vietnam. The equipment is too sensitive and not maintainable in the SEA environment. As a result, all vans were removed from service and are being returned to the CONUS for repair and reissuing to stateside units. The replacement vans and their component parts are older but more reliable. This equipment is rugged, simple to maintain, and has been in the weather equipment inventory for years.

CONFIDENTIAL

AVHGC-DST

SUBJECT: Operational Report-Lessons Learned of Headquarters,
United States Army, Vietnam, Period Ending 31 January
1970, RCS CSFOR-65 (R2) (U)

(c) RECOMMENDATION: To support future conflicts, two different types of weather observing stations are recommended; one for semi-permanent installations and one for rapid-reaction type operations (CWT locations).

1. Semi-permanent Operations: "Tactical Mobile" weather observing equipment is needed to support ground forces when sufficient advance notice and time can effect a move and relocate in a new area. Equipment developed for observing teams supporting this type operation would be:

- a. Rugged for field (combat) use.
- b. Relatively simple but capable of providing facilities for professional observation.
- c. Capable of providing soil and atmospheric information in preparation of soil trafficability and chemical/biological forecasts.
- d. Simple to erect and strike.
- e. Maintainable by a 5-level weather equipment repairman with a minimum of intermediate maintenance support.

2. Rapid-Reaction Operations: "Tactical Portable" weather equipment is needed to support ground forces that have a capability to relocate to new areas with a minimum of advanced notice. Equipment required by observing teams supporting this type of operation should be:

- a. Especially rugged for rough field (combat) use.
- b. Simple but capable of giving the type observations required by Visual Flight Rules type operations.

CONFIDENTIAL

CONFIDENTIAL

AVHGC-DST

**SUBJECT: Operational Report-Lessons Learned of Headquarters,
United States Army, Vietnam, Period Ending 31 January
1970, RCS CSFOR-65 (R2) (U)**

c. Capable of providing soil and atmospheric information in preparation of soil trafficability and chemical/biological forecasts.

d. Erect and strike in minimum time.

e. Maintainable by a 5-level weather observer.

(2) Dissident Activities.

(a) **OBSERVATION:** Efforts by dissidents and agitators to promote anti-Vietnam War demonstrations and "peace" movements originating in the United States have surfaced in US Army, Vietnam. These dissident activities and other activities include two recent attempted anti-Vietnam War demonstrations aimed at involving US military personnel in Vietnam, which resulted in failure. A "Fast for Peace" was publicized as scheduled to take place at the 71st Evacuation Hospital, Pleiku, during the Thanksgiving Day Dinner. No demonstrations took place, though an estimated 25 personnel allegedly abstained from dinner (but ate Thanksgiving meal in billets). Similarly, a "Peace Happening" was held on Christmas Eve in John F. Kennedy Square, Saigon, instigated by an ex-Overseas Weekly reporter, Richard Boyle. While six to eight US military personnel appeared in the square, they quickly departed when advised that Army Regulations prohibit demonstrations by military personnel and directed to leave the area.

(b) **EVALUATION:** It is evident that an increasing effort is being made to involve US military personnel stationed overseas in anti-Vietnam War demonstrations. For example, the Student Mobilization Committee to End the War in Vietnam (SMC) is stressing GI participation and has dispatched one of its "Executive Committeemen," ex-US Army soldier Allen Myers, on an around-the-world trip to "coordinate international anti-Vietnam War activities." He expressed a desire to meet with military dissenters (overseas) whenever possible. When informed of Myers' background, Republic of Vietnam (RVN) officials

CONFIDENTIAL

CONFIDENTIAL

AVHGC-DST

SUBJECT: Operational Report-Lessons Learned of Headquarters,
United States Army, Vietnam, Period Ending 31 January
1970, RCS CSFOR-65 (R2) (U)

barred his entry into RVN. Effective command action has thwarted and can continue to thwart dissident activity. In the case of one of the abortive demonstrations above, the CG, 44th Medical Brigade, issued guidelines on handling demonstrations to all his subordinate commands prior to Thanksgiving, reminding them that US Army personnel are not permitted to demonstrate while in uniform or while serving overseas. In the second instance, the Christmas Eve "Peace Happening" in Saigon, similar guidance was announced by the United States Army Headquarters Area Command Provost Marshal to military personnel present and they left the area immediately. The efforts of known dissidents/subversives to enter RVN and to agitate dissidence and dissent can be thwarted by the GVN. Efforts to organize dissident activities in Vietnam have been ineffective to date, continuing attempts to agitate dissidence and dissent can be expected.

(c) RECOMMENDATION: No action by higher headquarters required. Action within the command requires all commanders to be thoroughly familiar with the provisions of para 46, AR 600-20 (prohibiting demonstrations by military personnel) and that command actions be prompt, yet represent low-keyed efforts aiming at the identification, removal from the scene and isolation of agitators while avoiding undue physical confrontation and minimizing adverse publicity.

c. (C) OPERATIONS. Planning for Base Closures and
Redisposition of Troops.

(1) OBSERVATION: Initial planning considerations for base closures and troop redisposition have not been coordinated with field commands prior to the development of redeployment troop lists.

(2) EVALUATION: Current procedures for the development of troop lists for phased redeployment packages require planners to assume that certain base closures and in-country troop unit redispositioning will be accomplished in conjunction with the redeployment phase; troop lists are developed accordingly. Subsequent to these actions, representatives from field commands are brought in to confer

CONFIDENTIAL

AVHGC-DST

SUBJECT: Operational Report-Lessons Learned of Headquarters,
United States, Army, Vietnam, Period Ending 31 January
1970, RCS CSFOR-65 (R2) (U)

with USARV planners and to present operational concepts based on guidance received from the major tactical commanders. Experience has revealed that, in many instances, there is considerable disparity between field commanders' concepts and those assumptions upon which planning has been based. A problem is thus created in that certain support units which have already been committed to the redeployment troop list, in order to satisfy total space requirements, are still required to fulfill in-country support missions or to satisfy new support requirements based on troop allocations. The procedure, as described, has created difficulties in the logical development of troop lists for phased redeployment of US Forces from RVN.

(3) RECOMMENDATION: No action by higher headquarters required. Action within the command is that planning affecting troop redeployments will be coordinated with the field commands and MACV before any commitments are made in the selection of units for inclusion on redeployment troop lists.

d. (U) ORGANIZATION: Civil Affairs Support.

(1) OBSERVATION: US Army Civil Affairs companies, as organized under TOE 41-500D, are most effectively used to provide civil affairs support to tactical and logistical units.

(2) EVALUATION: US Army Civil Affairs companies were organized and deployed to RVN to provide civil affairs support to US Army tactical and logistical units. However, in most cases, these units have been employed in direct support of province senior advisors. The PSAs need US military personnel with a few specific skills, but do not need an entire CA platoon. Consequently, one or two platoon members are effectively used, but the other members perform tasks which are not commensurate with their abilities or the mission of the CA unit. The most effective use of CA platoons, as organized, is to provide civil affairs support to US military units, and coordination between US units and advisory personnel.

AVHGC-DST

SUBJECT: Operational Report-Lessons Learned of Headquarters,
United States Army, Vietnam, Period Ending 31 January
1970, RCS CSFOR-65 (R2) (U)

(3) RECOMMENDATION: No action by higher headquarters required. Action taken within the command is to advise MACV that US Army civil affairs units should be used to provide civil affairs support to US military units. Support for advisory teams should be by assignment of individuals with specific required skills.

e. (U) TRAINING. Sentry Dog Manual.

(1) OBSERVATION: The inherent problems from frequent personnel rotations in Vietnam cause a requirement for continuous on-site training in sentry dog units. A need exists at each location where sentry dogs are employed for a field manual that provides detailed guidance in such aspects as the correct maintenance of records, training and utilization.

(2) EVALUATION: At present the only Department of the Army guidance on sentry dogs is contained in AR 190-12, Sentry Dogs. While FM 20-20, Military Dogs Training and Employment, addresses sentry dogs, it is too general in application as it relates to all types of military dogs. There is presently in existence Air Force Manual 125-5, USAF Sentry Dog Program, 15 Nov 67, which provides the information needed by Military Police Corps sentry dog organizations.

(3) RECOMMENDATION: That Air Force Manual 125-5 be designated as a joint service manual to provide the reference needed at the unit level. This recommendation was submitted to TPMG by letter, this Headquarters, subject: Sentry Dog Manual, 25 Oct 69.

f. (U) LOGISTICS.

(1) Menu for Royal Thai Army.

(a) OBSERVATION: Although a special ration has been developed for the Korean Army in Vietnam, the Royal Thai Army Volunteer Force (RTAVF) is being issued the same Field Ration A that is issued to U.S. Forces in RVN.

AVHGC-DST

SUBJECT: Operational Report-Lessons Learned of Headquarters,
United States Army, Vietnam, Period Ending 31 January
1970, RCS CSFOR-65 (R2) (U)

(b) EVALUATION: The RTAVF is not able to properly utilize this A Ration since it contains so many unfamiliar food items and issue factors of meat, bread, flour, and many other items are much too high. A great deal of this food is exchanged with the Vietnamese for food items that conform more closely with the Thai diet. The dietary consultant, by working with 1st Logistical Command, the Thai Army, G4, and the Food Service Office of II Field Forces, has devised a 28 day menu utilizing food items on the existing A Ration menu plus some fresh produce from Thailand, that is an integral part of the Thai diet. The RTAFV approved the menu changes and 1st Logistical Command has agreed to buy the necessary produce from Thailand. MACV approved the Thai menu on the 9th of January for implementation by the 1st Logistical Command.

(c) RECOMMENDATION: That the standard menu be adjusted to meet dietary habits of other nations when the U.S. Army is providing ration support to Allied Forces.

(2) Maintaining Non-Standard PSYOP Equipment

(a) OBSERVATION: US Army combat units have experienced difficulty in maintaining non-standard PSYOP equipment.

(b) EVALUATION: In 1967 and 1968, USARV units received approximately 57 AEM-ABS-4 Public Address Systems. However, this equipment was not placed on MTOE or MTDA documents, definitive supply and maintenance procedures were not established by USARV units, and field expedient measures were often applied to maintain equipment. As a result, the Army logistical system was not exercised, and units suffered high levels of non-operational PSYOP equipment. Recently, maintenance units providing general and back-up direct support for PSYOP equipment were designated. Emphasis has been placed on using the MILSTRIP system, and improvement of logistical support has resulted.

(c) RECOMMENDATION: No action by higher headquarters required. Action within the command is for direct and general support units to be designated to provide supply and maintenance support for all non-standard PSYOP equipment. Tactical units are encouraged to use MILSTRIP for this support.

AVHGC-DST

SUBJECT: Operational Report-Lessons Learned of Headquarters,
United States Army, Vietnam, Period Ending 31 January
1970, RCS CSFOR-65 (R2) (U)

(3) Turn Over of Ports.

(a) OBSERVATION: The local US/RVNAF committees studying the program of transferring port facilities to ARVN have been drafting agreements for the transfer of port operations without the benefit of guidance and concurrence from respective higher headquarters.

(b) EVALUATION: The concept, as envisioned by the Central US/RVNAF Committee, was that the local committees would coordinate and draft the agreement for the turnover of ports in their areas of responsibility. These agreements would be submitted to the Central Committee, and, if concurred in, be signed at the MACV/RVNAF JGS level. This procedure circumvents all intermediate headquarters and, consequently, there is no coordination between headquarters to lessen potential problem areas.

(c) RECOMMENDATION: No action by higher headquarters required. USARV will recommend to MACV that agreements be drafted by representatives of all headquarters concerned. Furthermore, each agreement should be staffed for comments, evaluations and recommendations by each headquarters. The necessary interaction between US and ARVN should be accomplished at the MACV/RVNAF JGS level.

(4) Pilferage of Rail Cargo.

(a) OBSERVATION: Pilferage of US cargo on the Vietnamese National Railway System (VNRS), especially in the Saigon Division and the Qui Nhon-Tuy Hoa portion of the Nha Trang Division, deterred US shippers from offering cargo for rail shipment, thus limiting full utilization and available VNRS assets and resulting in an excessive work load for available motor transport.

(b) EVALUATION: The missing keystone in the pilferage reduction program was the lack of any responsible party or means to enforce pilferage reduction. Several meetings between MACV, Traffic Management Agency (TMA), the Military Railway Security (MRS) Battalion advisors, the VNRS, and this headquarters resulted in a general agreement that the VNRS was the responsible agency but lacked an enforcement

AVHGC-DST

SUBJECT: Operational Report-Lessons Learned of Headquarters
United States Army, Vietnam, Period Ending 31 January
1970, RCS CSFOR-65 (R2) (U)

ability. It was further agreed that when MRS troops were available, as they were responsible for the security of the train passengers, and VNRS property, that they should also secure the train cargo from pilferage. In the Qui Nhon-Tuy Hoa area, the 2d Region TMA now has the VNRS and the 2d MRS Bn jointly signing for the train with a resultant reduction of pilferage and increase in cargo shipped via rail mode.

(c) RECOMMENDATION: No action by higher headquarters required. Action within the command was to request that MACV coordinate with GVN to have TMA, the VNRS and MRS troops expand their pilferage reduction campaign into the Saigon and Da Nang divisions as soon as possible.

(5) Excess Equipment and Supplies.

(a) OBSERVATION: Units are retaining excess equipment and supplies.

(b) EVALUATION: USARV Readiness Assistance Team reports reveal that units are retaining excessive amounts of equipment and supplies. This has burdened support facilities, caused errors in MTO&E computations, hindered the establishment of adequate maintenance basis, and resulted in waste of needed assets. Sufficient personnel were not programmed initially to conduct property account audits thereby causing serious discrepancies in accountability.

(c) RECOMMENDATION: Supply inspection and audit teams be established early in a campaign to insure best utilization of all available assets.

(6) Vehicle Serial Numbers.

(a) OBSERVATION: Vehicle serial numbers can easily be lost or modified.

(b) EVALUATION: Vehicle serial numbers are located on removable data plates. This permits loss of identity of vehicles thru removal or modification of data plates thereby increasing the difficulty in accountability as required by regulations. The ease with which a serial number can be changed also increases susceptibility to theft.

AVHGC-DST

SUBJECT: Operational Report-Lessons Learned of Headquarters,
United States Army, Vietnam, Period Ending 31 January
1970, RCS CSFOR-65 (R2) (U)

(c) RECOMMENDATION: Vehicle serial numbers should be stamped into the frame of all vehicles.

(7) Material Readiness Data.

(a) OBSERVATION: It is extremely difficult to gather valid and timely materiel readiness data.

(b) EVALUATION: USARV has consistently submitted late Materiel Readiness Reports to the Logistics Data Center, Lexington, Kentucky. The causes for the delays are wide geographical dispersion of units, some mechanical problems with key punch and data processing equipment, and most important, the fact that the key punch and data processing equipment for many units is not available within command channels. To prepare an accurate and timely Materiel Readiness Report within the allotted time frame, a working relationship between the personnel responsible for the data processing aspects of the report and the preparing unit is required. The geographical dispersion, high personnel turnover rates, and the fact that in many cases this working relationship is outside of direct command channels, make it extremely difficult to significantly improve the timeliness and accuracy of the report.

(c) RECOMMENDATION: That to the extent possible, responsibilities for the data processing of logistical reports remain within command channels where units are widely dispersed and have limited telephone contact.

(8) Maintenance vs Supply.

(a) OBSERVATION: Maintenance problems can be obscured by supply action.

(b) EVALUATION: In early 1969, a unit reported that it has experienced problems with the M102 fire control. The problems were not reflected on the Artillery Command Deadline Report, USARV, G4 initiated a survey to determine the extent of the problem throughout RVN. The survey revealed that unit maintenance activities were exchanging fire control hardware at a very high rate; however, the M102 was not deadlined due to the availability of sufficient serviceable hardware on-

AVHGC-DST

SUBJECT: Operational Report-Lessons Learned of Headquarters,
United States Army, Vietnam, Period Ending 31 January
1970, RCS CSFOR-65 (R2) (U)

had to permit immediate return of the M102 to service. Queries to the field on the problems in April 1969, resulted in the identification of inherent internal weaknesses which were apparent during firing and movement of the weapon. The problems were referred to AMC and actions were taken to strengthen the internal construction of the hardware as an interim measure while field evaluations were in progress aimed at producing a better design for the system. Ten sets of the completely re-designed fire controls are now being tested in RVN. The major new features include modified gear trains, a trail mounted shockproof carrying case, and quick mount/dismount feature. No conclusive test results are yet available, but the new material appears to offer significant improvements in reliability.

(c) RECOMMENDATION: That appropriate doctrinal guidance and courses of instruction include examples such as this with recommendations to user and support commanders, along with logistics staff officers, to be alert to situations of this type.

g. (U) COMMUNICATIONS. None.

h. (U) MATERIEL. Equipment Faults Found After Deployment.

(1) OBSERVATION:

a Equipment faults discovered after equipment is deployed adversely affect operational readiness rates and user confidence in the equipment.

b The M551 Sheridan offers several specific examples of equipment faults discovered in a major item subsequent to its deployment to Vietnam. Nearly all vehicles have had the recoil seals replaced at least once, in some instances immediately after firing the main gun for the first time. The grenade launchers on this weapons system have also presented some problems. The launchers are easily damaged, seldom used and in some cases dangerous to the crew. The sophisticated turret electrical components frequently fail and cause vehicle deadlines.

AVHGC-DST

SUBJECT: Operational Report-Lessons Learned of Headquarters,
United States Army, Vietnam, Period Ending 31 January
1970, RCS CSFOR-65 (R2) (U)

c Other significant examples of equipment failures discovered after deployment include: high incidence of cracked frames on 5-ton trucks, cracked steering arms on 10-ton trucks causing dangerous accidents, and design weaknesses of the XM571E1 articulated carrier. More realistic test standards are needed to detect probable equipment failure prior to deployment.

(2) EVALUATION:

a Because of operational considerations, maintenance in a combat environment must often be accomplished in the field on an unscheduled basis with minimum periods available for stand down or reversion to non operational status. Additionally, maintenance is often conducted on site by the crew with limited technical and tool support from organizational and higher echelon maintenance personnel. In view of such operational constraints, it is essential that equipment be de-bugged and made as rugged and soldier proof as practicable prior to combat deployment.

b Test requirements should ensure that any equipment adopted is, in fact, capable of sustained efficient operation under the combat environment in which it will probably operate.

(3) RECOMMENDATION: That the USA Test and Evaluation Command (USATECOM) use more realistic testing standards and criteria in order to determine materiel failures before equipment reaches the field. Tests should be structured to expose the equipment, operator, crew and supporting maintenance personnel to stresses, protracted utilization periods and other adverse operational considerations experienced in a combat environment.

i. (U) OTHER. Nmo.

FOR THE COMMANDER:

4 Incl
1, 2 & 3 as
~~4. Distribution List~~
Incl 4 wd HQ, DA

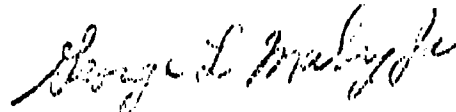

GEORGE L. MABRY, JR.
Major General, US Army
Chief of Staff

GPOP-DT (23 Feb 70) 1st Ind (U)
SUBJECT: Operational Report of HQ, US Army, Vietnam, for Period Ending
31 January 1970, RCS CSFOR-65 (R2) (U)

HQ, US Army, Pacific, APO San Francisco 96558 1 APR 1970

TO: Assistant Chief of Staff for Force Development, Department of the
Army, Washington, D. C. 20310

1. This headquarters concurs in subject report.
2. Reference paragraph 2f(7), page 52. The procedures for submission of the Material Readiness Report, DA Form 2406, have been revised effective with the submission of the 3d quarter report for reporting period ending 20 April 1970. Under the revised procedure, the hard copies of the DA Form 2406 will be mailed direct from US Army, Vietnam, to Lexington Blue Grass Army Depot.

FOR THE COMMANDER IN CHIEF:



C. L. SHORTT
CPT, AGC
Asst AG

USNAV Engineer Section
(TDA Authorizations)

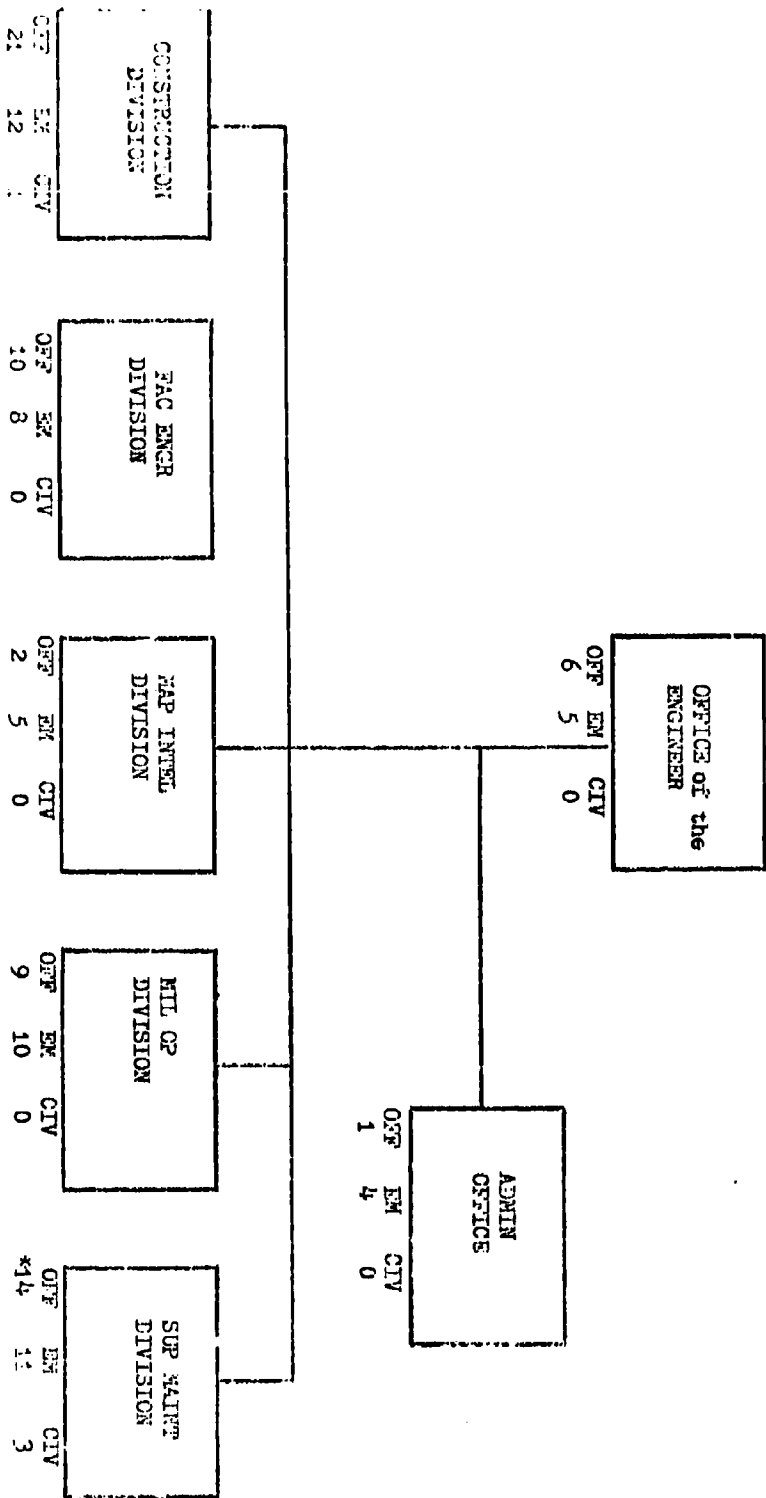

TOTALS
*OFF - 53
EM - 57
CIV - 3
TOTAL - 113

* Includes one warrant officer

USARCAV Organization

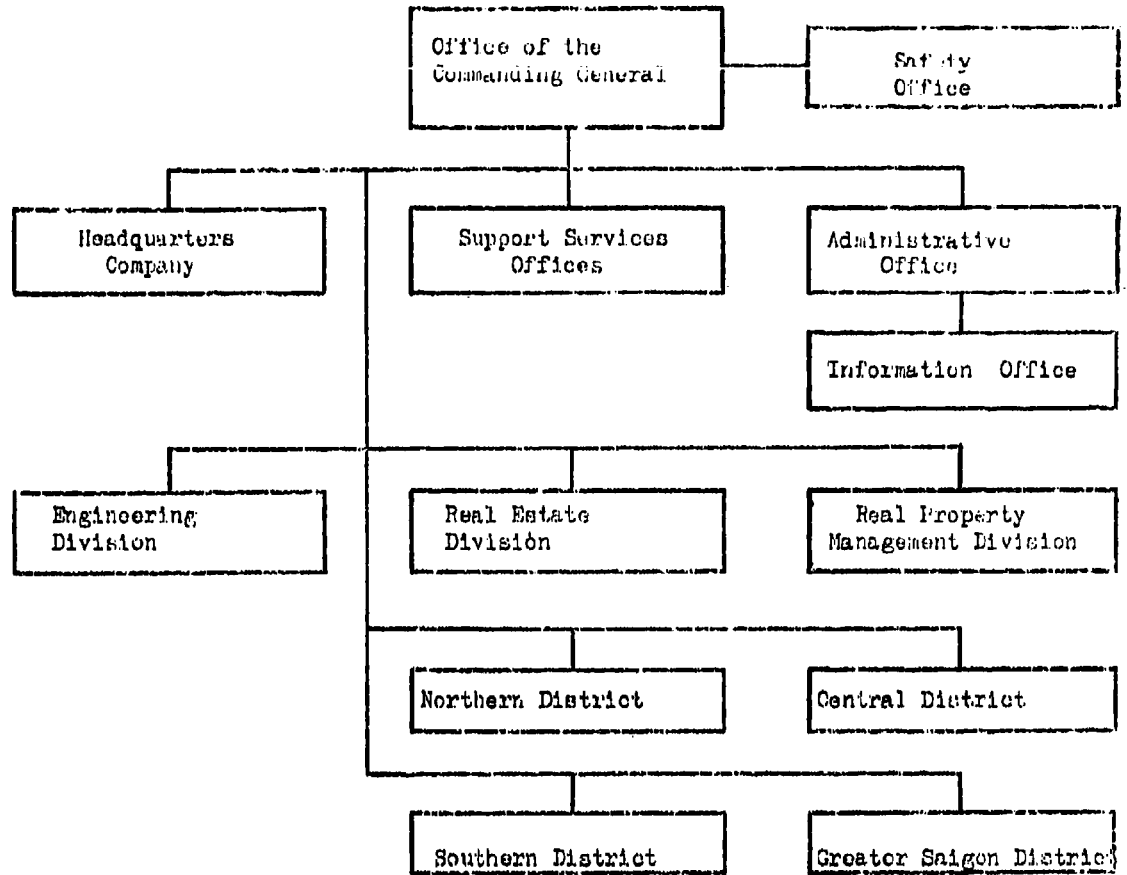

HQS PSNL AUTH

OFF - 94 US - 18
 EM -125 LN - 60
 WO - 3

TOTAL - 300

US ARMY ENGINEER COMMAND, VIETNAM (PROVISIONAL)

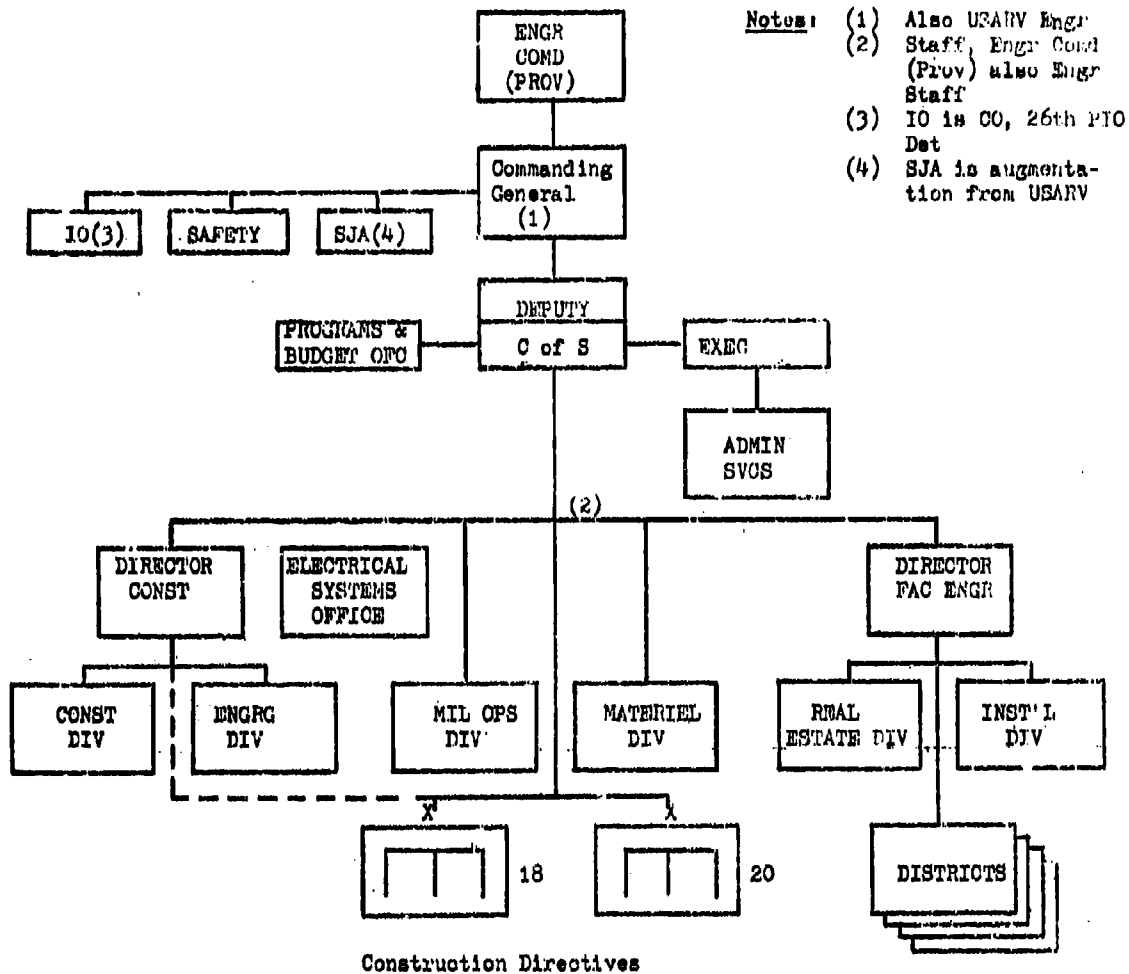

- Notes:**
- (1) Also USARV Engr Staff, Engr Cond (Prov) also Engr Staff
 - (2) IO is CO, 26th PTO Det
 - (4) SJA is augmentation from USARV

UNCLASSIFIED

Security Classification

DOCUMENT CONTROL DATA - R & D

(Security classification of title, body of abstract and indexing annotation must be entered when the abstract report is classified)

1. ORIGINATING ACTIVITY (Corporate author)		2a. REPORT SECURITY CLASSIFICATION	
HQ, OACSFOR, DA, Washington, D.C. 20310		CONFIDENTIAL	
		2b. GROUP	
		4	
3. REPORT TITLE			
Operational Report - Lessons Learned, HQ, United States Army, Vietnam			
4. DESCRIPTIVE NOTES (Type of report and inclusive dates)			
Experiences of unit engaged in counterinsurgency operations, 1 Nov 69 to 31 Jan 70			
5. AUTHOR(S) (For name, middle initial, last name)			
CG, United States Army Vietnam			
7. REPORT DATE		7a. TOTAL NO. OF PAGES	7b. NO. OF REFS
23 February 1970		58	
8. CONTRACT OR GRANT NO.		9a. ORIGINATOR'S REPORT NUMBER(S)	
9. PROJECT NO.		701046	
N/A			
c.		9b. OTHER REPORT NUMBER(S) (Any other numbers that may be assigned this report)	
d.			
10. DISTRIBUTION STATEMENT			
11. SUPPLEMENTARY NOTES		12. SPONSORING MILITARY ACTIVITY	
N/A		OACSFOR, DA, Washington, D.C. 20310	
13. ABSTRACT			