

UNCLASSIFIED

AD NUMBER

AD493816

LIMITATION CHANGES

TO:

Approved for public release; distribution is unlimited.

FROM:

Distribution authorized to U.S. Gov't. agencies and their contractors;  
Administrative/Operational Use; 01 JUL 1947.  
Other requests shall be referred to Office of Naval Research, 875 North Randolph Street, Arlington, VA 22203.

AUTHORITY

ONR ltr dtd 13 May 1970

THIS PAGE IS UNCLASSIFIED

JUL 22 1954

AD-493816

UNITED STATES NAVY

PROJECT SQUID

QUARTERLY PROGRESS REPORT

1 July, 1947

NEW YORK UNIVERSITY

POLYTECHNIC INSTITUTE OF BROOKLYN

PURDUE UNIVERSITY

CORNELL AERONAUTICAL LABORATORY

PRINCETON UNIVERSITY

AD-493816

QUARTERLY PROGRESS REPORT

PROJECT SQUID

CONTENTS

New York University . . . . .	1
Polytechnic Institute of Brooklyn . . . . .	17
Purdue Research Foundation and Purdue University . . .	55
Cornell Aeronautical Laboratory . . . . .	47
Princeton University . . . . .	33

QUARTERLY PROGRESS REPORT

1 July 1947

PROJECT SQUID

New York University  
New York, N. Y.  
Navy Department Contract  
N6ori-11, Task Order II

## INTRODUCTION

During the second quarter of 1947, technical progress attained by Project Squid at New York University has begun to give a real idea of the future possibilities of research in the directions of attack chosen by this group. Combustion studies are continuing, with several interesting and original observations and ideas having been developed. Instrumentation problems are becoming ironed out for most of the types of observational instruments thus far studied or designed. Theoretical work for the most part necessarily waits on the outcome of the fundamental experimental studies, but where the data have become available, as in the moving flame studies, satisfactory results have been achieved. The field tests, which originally were planned for securing much of the fundamental physical data, have finally started and show great promise of fulfilling the expectations.

The Squid staff has now become more unified by moving most of its members to the University Heights laboratories. This will help in making the interchange of ideas and results easier and more rapid. Because much of the future work will be done in field tests, the test equipment and facilities of many kinds are being mounted in mobile units which have recently been acquired. This equipment includes an electronic instrumentation trailer, a power and air supply truck, a shop truck, a blower trailer, a general field trailer, and a trailer mount for the JB-2 pulse jet.

## PHASE NO. 1

In connection with pulsating jet engines: to undertake theoretical and experimental investigations of (1) flame motions with controlled initial turbulence, (2) stationary flames with controlled turbulence, (3) suitable theoretical models based on the above observations, and (4) statistical mechanics of non-uniform gases.

### SUMMARY

Work on flame velocity and combustion has continued mainly with an accumulation of experimental data and the theoretical application of this data. The Merlin engine blower for stationary flame studies is nearing completion.

### EXPERIMENTAL

Moving Flames in Tubes. Experiments are being undertaken in order to provide data for a theory of combustion and flame propagation in media with eddy turbulent motions.

In the first series of experiments, a waffle-like grid containing twenty-one openings one centimeter square was placed four inches from the top of a vertical pyrex tube which was four feet long. The top end was closed, and contained a spark igniter. The tube was filled with a stoichiometric propane-air mixture. Motion of the flame down the tube to the bottom end was photographed with a high speed camera (1000 frames per second).

Figure 1 is an average curve of velocity of flame propagation versus distance from igniter. This average curve duplicates, quite satisfactorily, a curve given for a single experiment in the Semi-Annual Report of January 1, 1947 (Figure 3, curve 1a of that report). For individual runs, the timing device is not yet as accurate as could be desired, and this is being rectified.

Photographs were also taken of flame propagation in an eight-foot tube of four-inch diameter. The same grid was placed as before at four inches from the igniter. Figure 2 shows a representative curve giving a plot of distance of flame front from igniter versus time. A distinguishing characteristic of the curves obtained in this tube is their wavy nature, the cause of which is being studied.

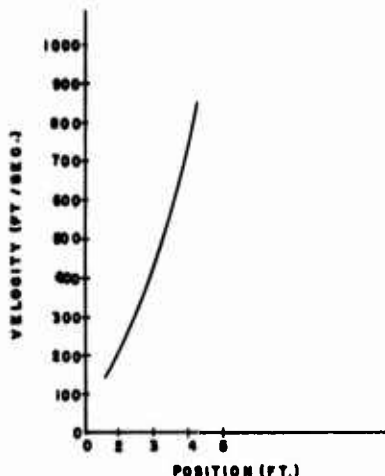

Figure 1.

Four-foot Tube with Grid

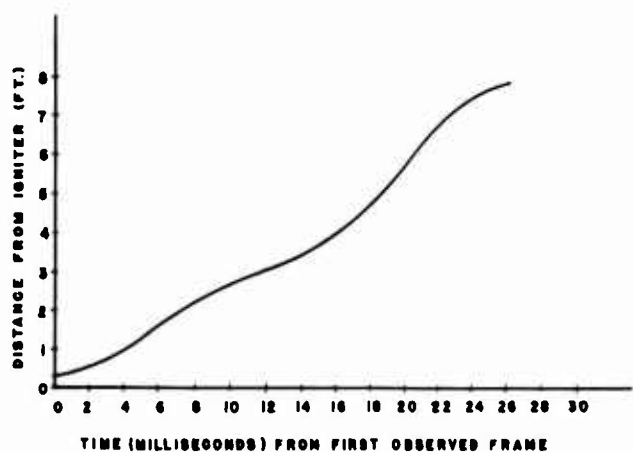

Figure 2.

Eight-foot Tube with Grid.

Similar experiments were made of flame propagation in the eight-foot tube with no grid. An example of the results obtained from these experiments is graphed in Figure 3 where again time is plotted versus distance of flame front from igniter.

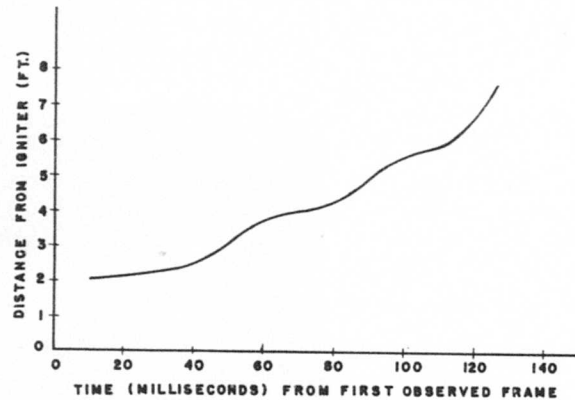

Figure 3

Eight-foot Tube without Grid

Velocities in these cases average 40 feet/second, which was the average velocity in the four-foot tube without grid.

A schlieren system has been set up using a spherical mirror (16-3/4" chord, radius of curvature 90") to study the gas flow at the outlet of the four-foot flame tube. The light source is a Western Union 100 Watt zirconium lamp. Figure 4 reproduces six frames of schlieren movies taken at the bottom of a tube containing no grid.

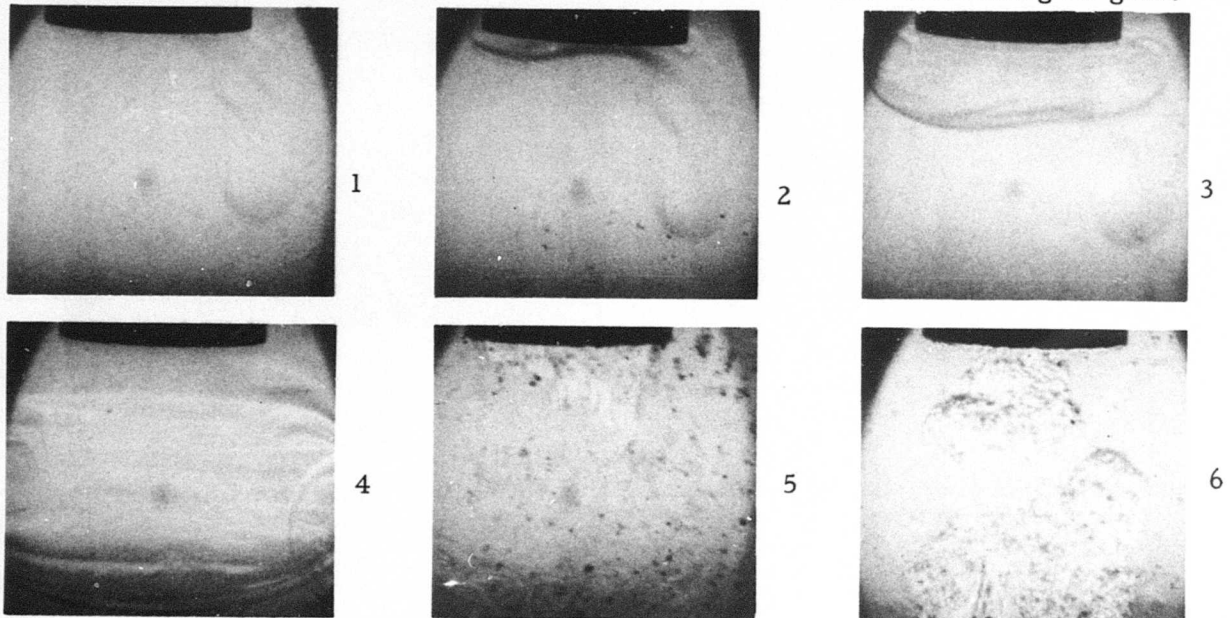
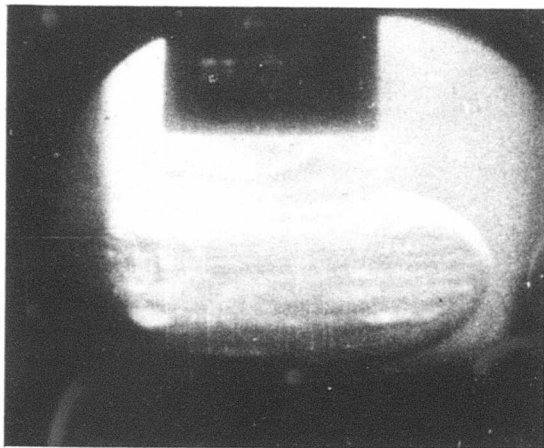
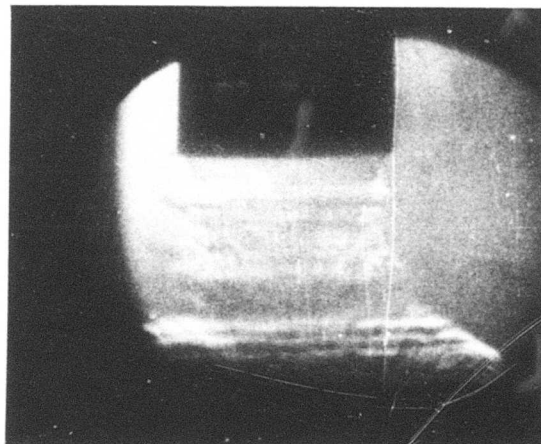

Figure 4. Schlieren photographs of gas flow from the end of a moving-flame tube before (Frames 1-4) and after (Frames 5,6) the burning gas reaches the end.

The first five pictures shown were made at intervals of about ten milliseconds. The sixth frame was made four milliseconds after the fifth. The first four frames show the propane-air mixture flowing from the tube as burning is taking place in the upper part of the tube. The last two frames are presumably pictures of the burning gases. Figure 5a shows propane-air mixture issuing from the mouth of the tube after ignition and before the flame front reaches the end of the tube.



1



2

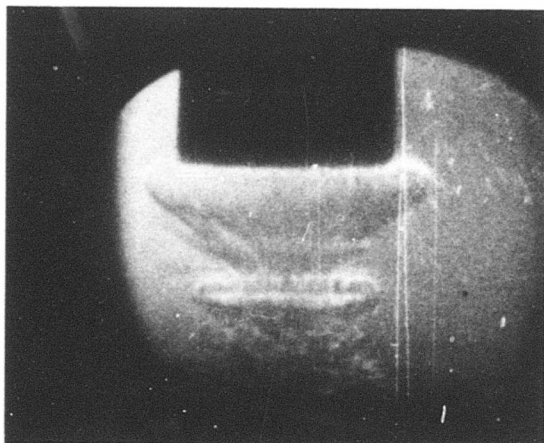

3

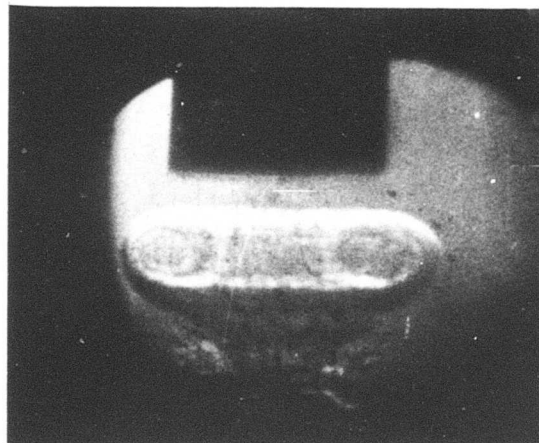

4

Figure 5a. Propane-Air Mixture issuing from mouth of four-foot flame tube after ignition and in front of flame.

This tube was without a grid. Figure 5b shows the same type of performance except that the No. 2 grid has been placed 6" from the top of the four-foot tube.



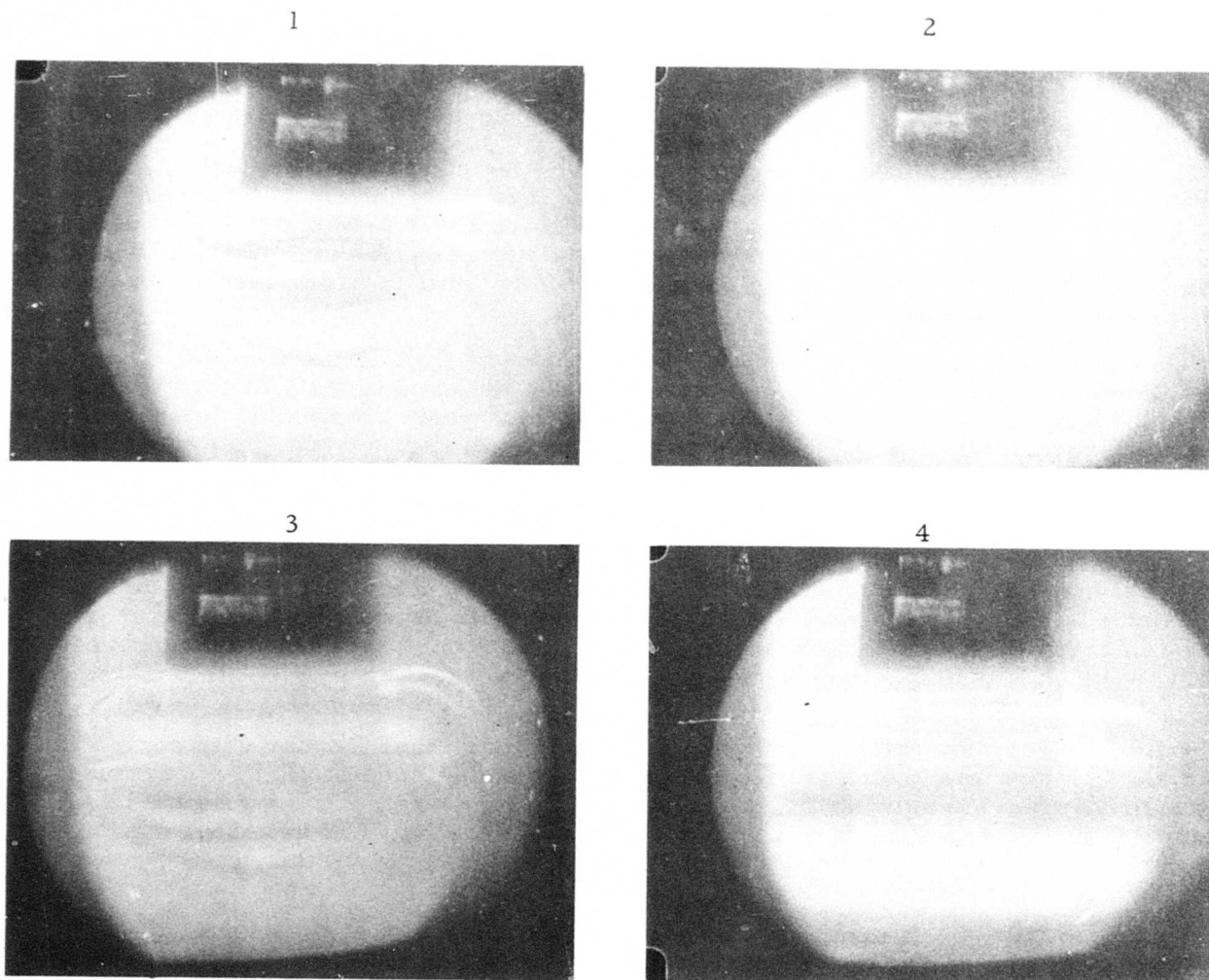

Figure 5b. Propane-Air Mixture issuing from mouth of four-foot flame tube in front of flame.  
#2 Grid six inches from top of four-foot tube.

Studies are proceeding with a view to application to the inflow problem at the tail pipe of the jet.

Figure 6 reproduces three frames of non-burning gas flowing from the tube in an experiment in which a grid was placed at the bottom end of the tube.

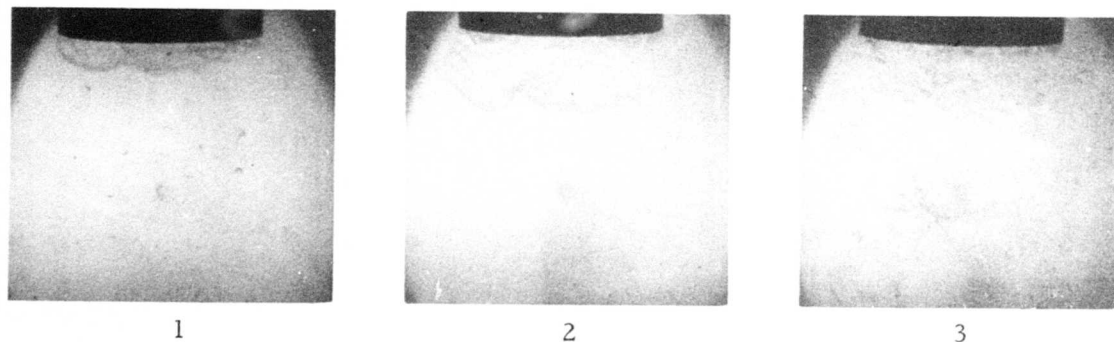

Figure 6. Non-burning gas flow from the moving flame tube in which a grid has been placed near the opening.

This grid contained three in-line holes one-half inch square. Gas issuing from the three holes can be seen in the pictures. Approximately eight milliseconds elapsed between the frames.

Preliminary attempts have been made to study the effect of sound waves on flame in the tube. An audio signal tuned to the 5th harmonic resonant frequency of the eight-foot tube, was fed into the bottom of the tube, and a 5-watt drive was used. There did not appear to be much effect on the flame, possibly due to the low power used. A transducer has been designed and is being built in order that a more powerful signal can be used.

Shock Ignition. Work on the shock tube has been mainly concerned with design problems because of the necessity of performing the experiments at high temperatures. Much time was devoted to testing of various gasket materials to check operating characteristics at 900° C. and 600 psi. A method of bursting the sheet metal diaphragms with a probe in order to generate a shock wave, was found to be unsuccessful, and a new method has been devised which utilizes the discharge of seven 3000-volt, 14 MFD condensers connected in parallel across a spark gap in the compression chamber. Tests show that sufficient shocks have been developed through the condenser discharge to break diaphragms which ordinarily require 35 psi hydrostatic bursting pressure. Thus the new method is to build up the pressures in the compression chamber to within a few psi of bursting pressure and then to discharge the condensers, creating a small additive pressure sufficient to break the diaphragm.

Stationary Flames: Meker Burner. A remodelled Meker Burner with controlled gas and air flow has been used for this work. It is designed so that temperature, turbulent diffusion angle, and mean flow velocity measurements may be made. A temperature map was made of the flame, using the sodium line reversal method, i.e. temperatures were measured along two directions, one up through the center and the other horizontally across the flame.

In refinements of our previously reported experiments, the diffusion angle will be measured by photography of the spread of sodium vapor from a probe inserted in the flame, and the gas velocity will be measured either by injection of fine metal particles and the use of a high speed motion picture camera or streak photography of the sodium boundary as the probe is withdrawn.

Stationary Flames: Merlin Engine Blower. In order to study under quasi-steady conditions the effect of large scale eddy turbulence on the velocity of a flame, it is planned to try to "hold" a flame stationary in a tube through which a combustible turbulent mixture is flowing. Since effects of turbulence are presumed to vary with the size of tube used, a flame tube of approximately four-inch diameter was chosen as being the minimum size that could safely be used. To provide the desired maximum air velocities in the flame tube, it was necessary to have an air compressor with a maximum capacity of approximately 18,000 pounds of air per hour (5 lbs/second).

Mr. George Hudson - NYU - Project  
(Bronx) Lead

For the purpose of obtaining this air, a Merlin Engine with a 2-stage supercharger has been modified to operate as a naturally aspirated engine, while the superchargers are used as air compressors. Figure 7 shows how the engine is mounted on a trailer and how the controls and the cabinet for the electrical system are being installed.

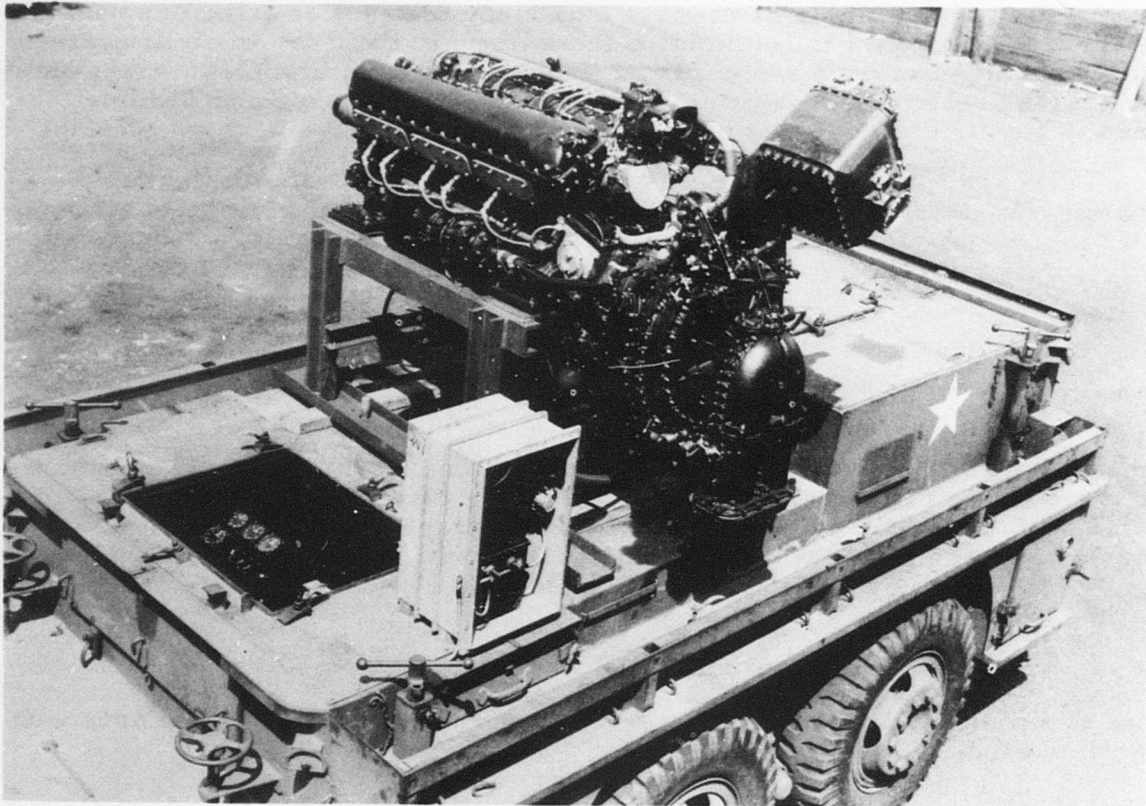

Figure 7. The Merlin Engine Blower mounted on the trailer.

V-1650 →

In addition to the equipment shown, a flywheel, constructed from a Curtis-Electric propeller hub, will be mounted on the engine; an oil tank, a coolant tank, an oil cooler, a compressed air cooler, and mufflers will be mounted on top of the trailer. The fuel tank will be installed inside.

#### THEORETICAL

Combustion in Flame Tubes. Work is in progress on incorporating data obtained in the moving flame experiments in a theory using the same type of one-dimensional formulation indicated in the AMG Report 152 referred to in the Semi-Annual Report. First order perturbation calculations have been completed for slow and for fast flames respectively, corresponding approximately to those in the flame tube with and without the grid. The resulting theoretical curves agree well, in general, with the observations. The first order perturbation is being checked against a detailed numerical solution of the non-linear aero-thermodynamical equations, using the method of multiple characteristics. In these theoretical treatments the flame speed relative to the medium, and the effective rate of release of heat in the combustible mixture, are treated as constant.

Flow at End of Jet Tubes. Of particular interest from the viewpoint of theory is the projected experimental study of the flow pattern at the end of real and simulated pulse jet tubes, using schlieren and illuminated particle techniques.

Non-Uniform Gases. At present the work on the mathematical theory of non-uniform gases is being extended to the case of reaction intermediates in equilibrium with a non-uniform chemically inert gas. This study involves as a first approximation the solution of the Maxwell-Boltzmann equation up to the first order derivatives in velocity and temperature for arbitrary force laws between colliding molecules. This part of the problem has, in principle, been solved by Enskog and Chapman. It is planned to clarify and systematize their work and make numerical calculations in the coming months.

#### FUTURE PLANS

Further data is to be obtained in the moving flame experiments using a tube of rectangular cross section and schlieren technique. Studies of the unsteady flow pattern at the ends of jet tubes will be intensified. The effect of sound waves on combustion in the moving flame tube is to be investigated.

#### PHASE NO. 2

In connection with liquid rockets and pulsating jet engines: To study (1) measurement of temperature dependence of conductivity and heat capacity of steels and other materials, (2) adiabatic calorimetry and metallography, (3) characteristics of heat transfer between hot flowing gases and walls, using measurements of gas velocity and temperature by radiation and thermocouple devices, (4) calculation of temperature changes in jet and rocket walls.

#### SUMMARY

Because of a change in personnel, this work has proceeded slowly. The apparatus is being remodeled.

#### EXPERIMENTAL

Earlier experiments on the specific heat of steel specimens under high rates of change of temperature have shown that radiation losses would have to be much reduced to obtain quantitative data. Accordingly, a glass vacuum chamber is now placed around a specimen, and the inner walls of this chamber are silvered. It is planned to record temperature versus time, as heretofore, by amplifying the output of a thermocouple welded to the center of the specimen. Voltage and current will also be recorded.

#### FUTURE PLANS

The specific heat studies are to go on as before with the study of a small specimen in an evacuated chamber rather than in a nitrogenous atmosphere.

### PHASE NO. 3

In connection with liquid rockets and pulsating jet engines: (1) to observe flame and particle motion, pressures, temperatures, densities, and effects of turbulence in pulsating and rocket jet devices; (2) to study water stream analogues for gas motion in pulsating jets and rockets in order to determine characteristics of simple theoretical models, and (3) to use the above for theoretical treatments of the internal ballistics of jet devices on the basis of justified simple models.

#### SUMMARY

Field tests of full-scale pulse jet engines have been made, and streak photographs taken of the flame motions within the tube.

#### EXPERIMENTAL

Boundary Conditions. A study of the operation of the valves in a pulse jet is being made. This includes studies of the effect of the ratio of the open area of the valves to the frontal area of the pulse jet, and of the types of end boundary conditions which should be used at the valves for theoretical purposes.

Full-Scale Pulse Jet. The setup of the PJ-31 engine at Lake Denmark, New Jersey, for experimental study and operation, using the JB-2 Pilotless Aircraft as a test stand, was completed and is shown in Figure 8.



Figure 8. The PJ-31 Pulse Jet Engine mounted on the JB-2 Pilotless Aircraft at Reaction Motors, New Jersey.

Valves  
Open

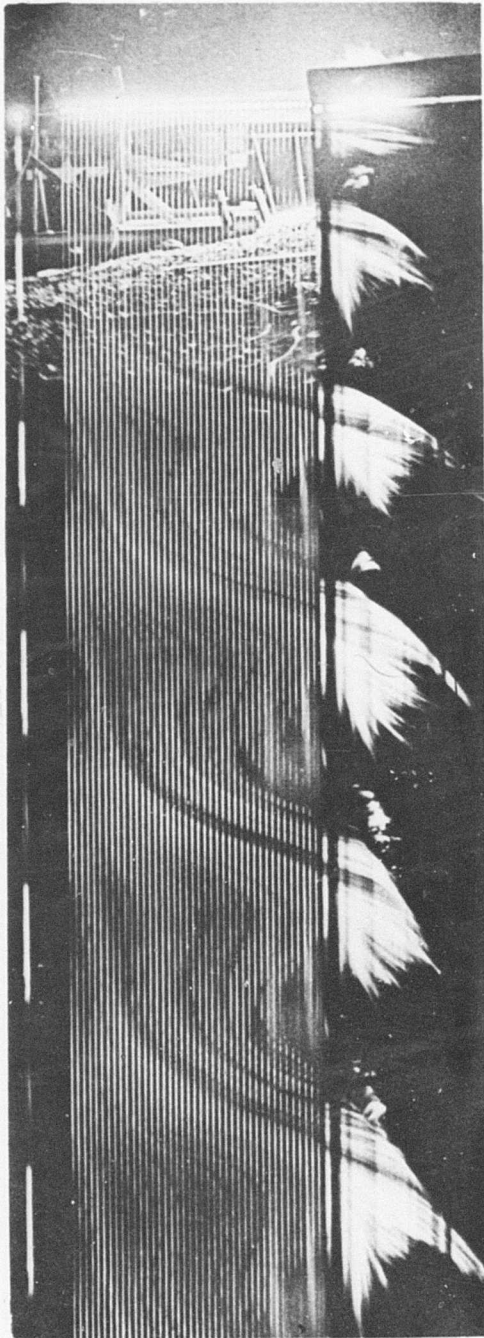

1 cycle  
25 milli-  
second  
period

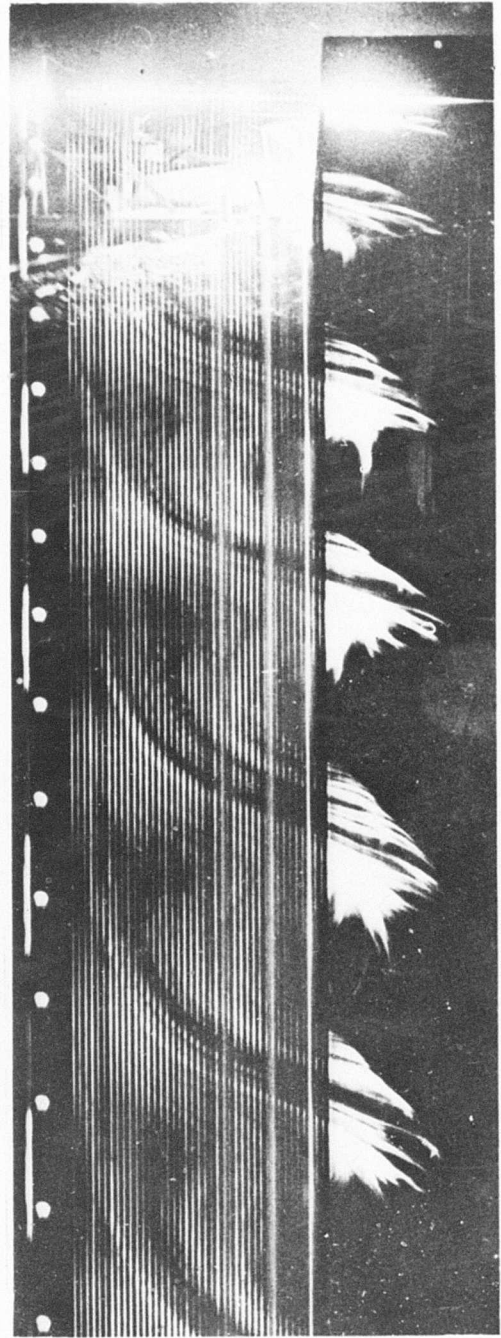

Figure 9

The PJ-31 engine in operation. Note the mirror ahead of the engine which reflects light transmitted through the reed valves, when open, from the interior.

**Figure 9-a  
(Holes Uncovered)**

Note the return flow followed quickly by the closing of the valves. A slit has been placed between the exhaust and the camera to delineate the flame motion out of the tailpipe.

**Figure 9-b**

(Holes covered with pyrex glass windows). Note that the burning areas are much more distinct here. Apparently part of the flame in each cycle is exhausted just prior to the appearance of the flame at the end of the tailpipe in the next cycle, due to the return flow.

The engine was started on June 11. After running the engine several times in the standard condition, 1/4 inch holes were drilled in a double row at three-inch intervals down the combustion chamber and tail pipe, as shown at the top of Figures 9-a and 9-b. It was thus possible to photograph the flame motions through these holes with a streak camera.

Figure 9-a shows these motions with the holes in the pulse jet uncovered, whereas 9-b shows the flame motions under steady normal operating conditions with the holes covered with pyrex glass windows. Also shown in these figures are overall conditions of the valves, that is, either open or closed. This was done by placing a mirror at the front of the engine to reflect any light, transmitted from the flames inside through the valves, into the camera. Timing marks are also shown in figure 9-b, from which the pulse frequency of about 40 per second may be inferred. A full analysis of these data has not yet been attempted.

Further preparations for extending these tests are being made. A camera is being mounted above the fuselage forward of the engine to photograph the valve action. A smoke generator is being prepared to study the flow at both ends of the engine during the run, using a sheet of light to illuminate the smoke.

#### **FUTURE PLANS**

It is planned to refine some of the techniques used in the field tests, and obtain more streak photographs of the flame motions, high-speed photographs of the valve action, and smoke photographs of the flow near the exhaust and intake ends of the pulse jet. Small jet studies are also to continue.

## PHASE NO. 4

In connection with liquid rockets and pulsating jet engines: to develop instruments for recording transient thrust and pressures, temperatures and densities of hot oscillating gases, and gas velocities.

### SUMMARY

Temperature measuring devices and pressure gauges have been developed and are in the final stages of calibration preparatory to using them in field tests.

### TEMPERATURE MEASURING DEVICES

A small quartz window was inserted in the combustion chamber of a Dyna-Jet engine. A photo-electric pickup with a sodium D-line filter in front of the cell is now used to record the flames in the chamber. This setup is shown in Figure 10.

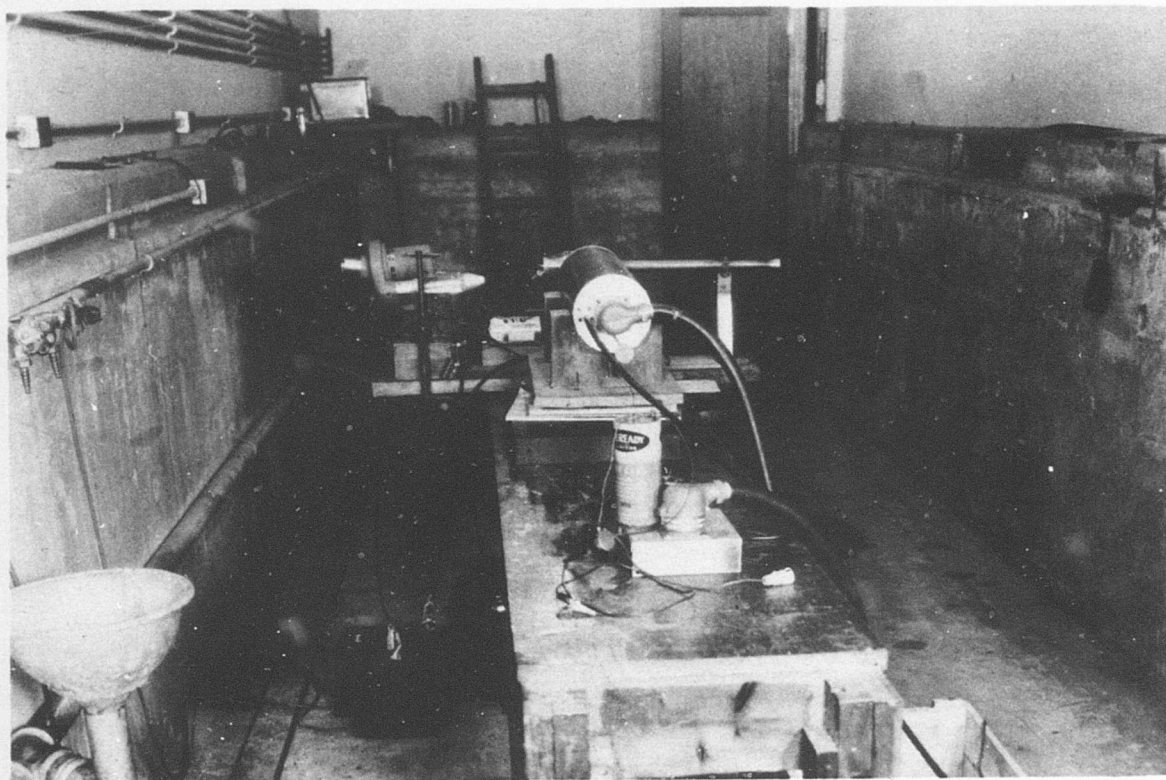

Figure 10. The Photo-multiplier Pick-up (center, foreground) in position for observing the flames in the Dynajet Engine (center, background)



Considerable response was obtained from the oscillating gases without the use of additives. When dry sodium salt was sprayed into the valve inlet of the Dyna-Jet, the response increased considerably.

Output from the cell is fed through an inverter circuit to a 5-inch cathode ray tube. The principal difficulty is that the frequency of the inverter is too low. Changes are being made in this circuit.

A calibration system for this photo-electric pickup is being developed, using a sodium lamp standardized at one point in the temperature scale, by a ribbon lamp and pyrometer. The general temperature response, presumed to follow Planck's law, will also be checked.

Also under consideration is a possible two-color system without the use of additives. Experiments will be conducted with the glass-walled jets to study the flame absorption and possible deviations from Planckian radiation.

Drawings have been completed and a contract let for the new wedge-type quartz thermocouple specially designed to record temperature in rocket walls.

#### PRESSURE PICKUPS

Condenser Gauge. Successful runs were made using the condenser gauge and frequency-modulation system to measure the pressure in a Dyna-Jet combustion chamber. The gauge was mounted in an improved water-cooled jacket, and temperature drift was noticeably reduced. Part of the oscillogram of pressure is shown in Figure 11.

#### DYNAJET PRESSURE CYCLE

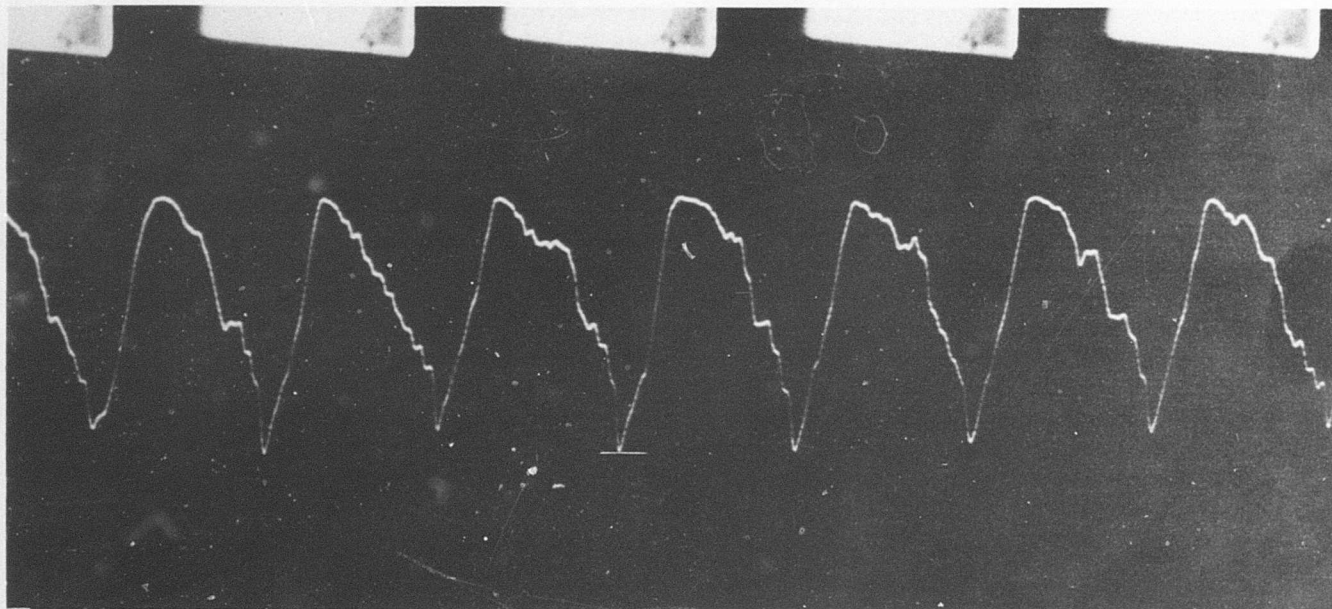

Time. Marks 120/sec.

Figure 11. Pressure Time Curve.  
DynaJet 200 cycles/second.  
Peak to peak pressure 10.5 pounds.

The repetition frequency was approximately 200 cycles per second and peak to peak pressure was approximately 10.5 pounds.

The gauge was calibrated by mounting it in a pressurized chamber and releasing  $15\frac{1}{2}$  pounds pressure suddenly by bursting a diaphragm. A sample calibration is shown in Figure 12.

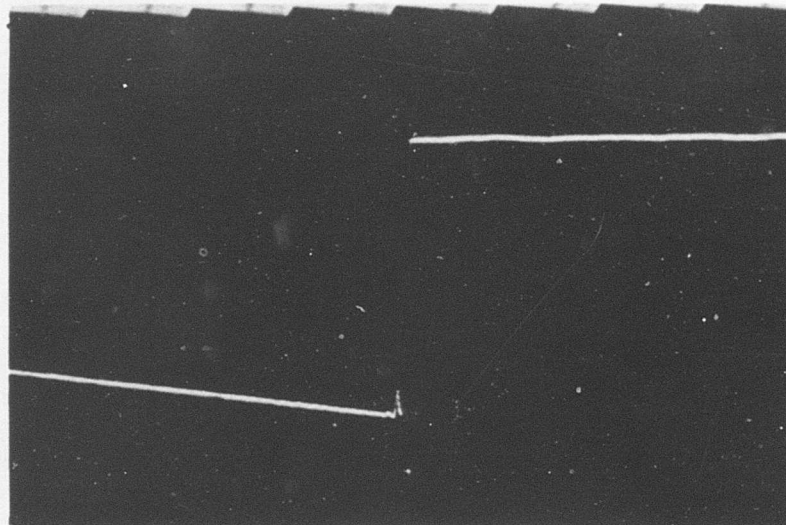

Figure 12. Calibration Curve F.M. Gauge.  
Pressure change =  $15\frac{1}{2}$  psi.  
Time scale .120 marks/second.

A study of the magnitude of the perturbing effect of the cooling jacket on the response of the gauge is planned, using a pulsed air jet. The effectiveness of the cooling will be studied by use of thermocouples.

Magneto-striction Gauge. Several runs of a Dyna-Jet engine with the magneto-striction gauge mounted on the combustion chamber have been made. Attempts are being made to eliminate a high harmonic component which is present. These high harmonics have also appeared when attempting to calibrate this gauge by the bursting diaphragm method.

A new diaphragm of rubber and cotton is being constructed for the periodically-varying-pressure calibrator.

#### FLUID VELOCITY MEASUREMENT

Tests are being carried out on a thermistor type anemometer. A gasoline flow meter of this kind has been designed, and special thermistors, flake sandwich type, are under construction by the Western Electric Company. Various types of circuits for use with the flow gauge are being investigated.

#### FUTURE PLANS

The temperature and pressure instrumentation will be used on field tests with the full-scale pulse jet engine, as will the flow meters when fully developed. It is also planned to develop instrumentation for making air velocity measurements in and around jet devices.

In connection with liquid rockets and pulsating jet engines: to study drag characteristics of pulsating jet and other devices under conditions of non-steady or of supersonic flow, using firing range photography, wind tunnel measurements, and theoretical investigation.

## SUMMARY

An analytical treatment of unsteady flow for compressible fluids is in progress, based on successive approximations alternating between flow around infinite cylinders and infinite planes.

## THEORETICAL

The bulk of the work in this period consisted in the analysis of the non-steady, compressible flow outside the jet tube, the flow assumed being generated by intake and exhaust fluid velocities of given form and time dependence, such as  $a + b \sin(\omega t + \alpha)$ . Preliminary experimental data with no ram air indicate fluid velocities around the tube of the order of 0.5M, except in a limited region near the exhaust end where velocities perhaps reach 0.8 or 0.9M.

In the absence of intimate knowledge of the mechanism of pulsed jets, the assumption of a potential flow (except for viscosity) was originally adopted. For a first approximation, the wave equations were linearized by dropping the products and squares of the ratios  $\frac{u}{c}$ ,  $\frac{v}{c}$  etc.; also viscosity and heat effects were disregarded. Several approaches were investigated for developing a workable method for the formulation of adequate wave functions, subject to the given boundary conditions. In the main, basic functions of the source-sink type, or Bessel-Fourier and Bessel-Spherical functions were employed and combined toward this end. In either case, use was made of the method of meeting boundary conditions at a series of discrete points; this is a parallel to the Collocation method and appears to be promising in cases, such as the present one, where simple analytical expressions may not be set up for the boundary conditions. Methods of successive approximations were also investigated. In particular, one was based on the distribution of velocities on planes and fictitious half-infinite cylinders, considered consecutively.

In the light of some preliminary photographic data obtained recently, the validity of the original assumption of a potential flow was re-examined and found questionable. There is evidence of definite vorticity at the exhaust end, in so far, at least, as the initial stages of gas ejection are concerned. The existence of discontinuity surfaces, regions of dead fluid, instability, etc., is also considered as likely. Whether such phenomena will also exist in a pulsating flow, and if so, under what form, is as yet unknown. The basic mechanism of jets is now under study, as is experimental work aimed at disclosing such information as may be necessary for a clear understanding of the pulsating flow phenomenon, preliminary to its analytical formulation.

## FUTURE PLANS

It is planned to continue the study of the mechanism of unsteady flow from and into jet tubes.

QUARTERLY PROGRESS REPORT

1 July 1947

PROJECT SQUID

Polytechnic Institute of Brooklyn  
Brooklyn, N. Y.  
Navy Department Contract  
N6ori-98, Task Order II



## INTRODUCTION

Research work on Project Squid at the Polytechnic Institute of Brooklyn has progressed during the past quarter to the point where it is expected to undertake experimental work on Phases 1, 3, and 4 in the near future. Test facilities, particularly for the testing of pulse jets under Phase 1, are still being investigated. It was expected that by this time pulse jet testing facilities of the Navy near Williamsport, Pennsylvania, would be available. Final decision by the Bureau of Aeronautics for use of these facilities has not as yet been reached.

Some members of the staff visited various research facilities and attended symposia as described below.

Dr. Yuan and Dr. Harrington attended the Sweat Cooling Conference held at Wright Field. In view of the progress of Dr. Yuan's work on Phase 3, he was invited at the meeting, along with Professor Henry, to visit the facilities at JPL/CIT in Pasadena to confer with Drs. Duvez, Tsien, and Summerfield. It appears that Dr. Yuan will be called upon to carry out the bulk of the analytical work in this field. Mr. Meyerhoff attended the Supersonic Symposium at Langley Field and Professor Henry, en route to California, attended the High-Temperature Materials Symposium at the NACA Engine Laboratories at Cleveland. Professor Harrington was a guest of the Navy at a recent conference and inspection of the Air Material Center facilities at Johnsville, Pennsylvania, and at League Island, Philadelphia.

An instrumentation program has been started in view of the expansion of experimental research now contemplated. Four projects have been inaugurated which apply more or less to all four phases. They can be stated simply as follows:

- (1) The use of x-ray methods for determining the density distribution in supersonic flows.
- (2) The use of x-ray methods for the determination of surface temperatures in combustion chambers and elsewhere.
- (3) Hot-wire anemometry for the measurement of temperature and velocity at a point in a flow field in the high subsonic and supersonic ranges.
- (4) The use of ultrasonic waves for the determination of temperature and velocity of flow in combustion chambers.

Dr. I. Fankuchen, head of the Division of Applied Physics, is cooperating on items (1), (2), and (4) above. The facilities of his division are available on these projects.

Some headway can be reported on item (2).

The macroscopic thermal expansion of solids reflects the more fundamental expansion of the crystal lattice. Back reflection x-ray scattering is very sensitive to change of lattice constants and can, therefore, be correlated to temperature. It was estimated that within the temperature range at which materials give reasonably sharp diffraction lines (upper limit not known for most materials), temperatures can be measured to less than 20° F. Three developments underway are:

- (1) The determination of the upper temperatures at which the method ceases to be useful.
- (2) The development of Geiger counter recording for the measurement of the x-ray scattering and consequent temperature measurement over short time intervals.
- (3) The incorporation of more refractory crystalline materials in walls to aid in the temperature determination.

Experiments have been conducted using a back reflection flat cassette camera on a specimen of stainless steel which is heated from the rear with an oxy-acetylene torch. The chromium radiation used was unfiltered. The specimen was located at

a distance of about  $2\frac{1}{2}$  cm. from the camera. The temperature change at the surface of the material was indicated by a change in the diameter of the resulting rings on the x-ray film. Results of the preliminary tests are shown in Figure 1.

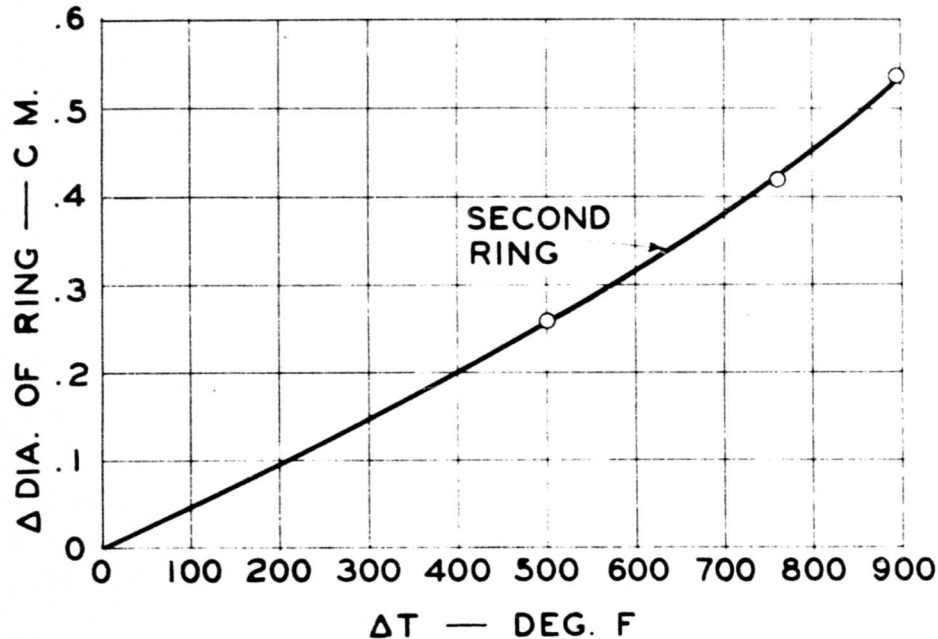

Figure 1.

Since the diameter of the rings can easily be measured to a tenth of a millimeter, temperature indications of less than  $20^{\circ}$  F can be detected. The sensitivity appears to increase slightly with increase in temperature up to the maximum temperature so far investigated. It is expected that the accuracy can be further increased by using other x-ray targets.

It appears that the method can be applied for measuring surface temperatures inside combustion chambers by directing the x-ray beam through a metallic window whose characteristics are such that the least possible absorption of the x-ray radiation used is obtained. It is expected to employ a Geiger counter to determine the position of the rings, rather than the photographic method, so that readings can be taken in about 10 seconds.

The principles used in attacking the fourth instrumentation project are outlined briefly as follows:

The velocity and gas temperature of flows in and external to combustion chambers are difficult to determine. It is felt that a well focused, approximately parallel beam of ultrasonic waves can be used to determine these quantities. A beam of ultrasonic waves aimed across a jet from one wall to the other would be deflected from its original path an amount depending on flow velocity and temperature. The deflection can be measured by means of a single moveable receiver or a set of fixed receivers on the side of the stream opposite the transmitter. By projecting such focused beams in varying directions, different paths for the beam would be produced as functions of mean flow velocity. Moreover, such beams can be pulsed and, in this way, the time of transmission beam propagation velocity and stream temperature can be accurately determined. The combination of these two types of data will, therefore, give definite information about both gas velocity and temperature. With

an appropriate receiver system, measurement of fluctuating velocity and temperature fields will probably be possible.

Work on instrumentation projects (1) and (3) have not progressed sufficiently to permit reporting details at this time.

## PHASE NO. 1

To study performance of reciprocating and rotating valve mechanisms at subsonic and supersonic velocities; namely, (1) the aerodynamic forces exerted in periodic compressible flow on periodically moving valve surfaces and (2) the dynamics of the valve mechanism itself under the action of the aerodynamic forces obtained from the first part.

### SUMMARY

The theoretical analysis of the inflow through periodically moving reed valves has resulted in a general solution for the hinged-type valves. A similar solution for the clamped-type reed valves is nearly completed.

The simplified gas-dynamical analysis of the pulse jet is in the process of solution and will provide the basis for the study of the actual aero-thermodynamical process.

An experimental setup for a wind tunnel investigation of the inflow variables and of the resulting turbulence in the combustion chamber is being prepared.

### PROGRESS

#### Analytical Work.

Reed Valve Studies: The formulation of the problem, the reasons for investigating both hinged and clamped reed valves, and the method of approach for the analysis were stated in earlier reports on this phase. The basic lines of the analysis can be summarized as follows:

- (1) Two methods have been developed for the study of the inflow through periodically moving reed valves. Both are based on the assumption of non-steady, compressible flows with isentropic change of state of the gas. The one method stipulates a two-dimensional and the other a quasi one-dimensional flow.
- (2) Different boundary conditions have to be satisfied for the hinged and the clamped reed valves at the supports.
- (3) The elastic and inertia properties of the reed have to be adapted to the time variable stream line pattern.

Using the quasi one-dimensional method of approach, the appropriate boundary conditions have been satisfied for the inflow through hinged reed valves, together with the condition that the mass distribution of the reeds must either be constant or space variable only. The most appropriate form of the velocity function was found to be a product of a time and space function  $[u = X(x).T(t)]$ . Pressure as well as area function are then expressed in terms of X and T, where X and T are expressions adaptable in form and arbitrary constants to the conditions mentioned above.

A similar solution for the clamped reed valve problem is expected to result shortly. The numerical evaluation of the examples for various initial and end conditions will be started in the near future.

Gas Dynamical Analysis: The study of the thermal dynamics of a pulse jet has further progressed. The problem has been simplified in the following manner:

The analysis of a quasi one-dimensional, compressible gas flow with heat input

and turbulent friction in a duct of constant or variable cross section was formulated. The velocity function was chosen as a trigonometric expression, variable in time, with coefficients, variable in space. A certain freedom was kept for the adaptation to the conditions of operation. Though the treatment is idealized, it contains the essential features, and the results will serve as a basis for comparison with experiments and for a refinement of the theory.

### Experimental Work

Test Model of PIBAL No. 1: The drawings of the test model of the pulse jet with rotating air intake valves and a tail pipe have been completed. Manufacture of the model will start as soon as workshop facilities are available. This model will be tested in the PIBAL wind tunnel. The purpose of these preliminary tests will be the determination of the flow phenomena through such valves and also of the scale of the resulting turbulence in the combustion chamber due to such an intake.

Instrumentation. Available information on the suitability of various pressure, density, and temperature recording instruments has been studied. A decision regarding the most suitable types will be made shortly. Further development work on instrumentation is mentioned in the introduction to this report.

### PLANS

Experiments to determine flow velocities and gas temperature in pulse jets by means of supersonic pressure waves will be started. The method for such measurements has been suggested by Dr. I. Fankuchen, Professor of Physical Chemistry at this Institute.

The analyses of the inflow through reed valves and the gas dynamical mechanism of pulse jets will be continued.

Suitable testing instruments will be prepared or acquired for the experimentation.

A thorough survey of the Williamsport site will be made to determine necessary additions to and modifications of the existing equipment.

### PHASE NO. 2

(1) To investigate causes of metal failure thus far encountered by evaluation of use tests on developed materials and (2) To investigate and develop new alloys to resist pressure, temperature, and erosion conditions existing in propulsion units by (a) modification of present alloys, (b) development of new alloys, and (c) use of powder metallurgy methods.

### SUMMARY

Studies of fatigue specimens are being continued. The first experimental extensometer for the modified creep machines has been completed.

Qualitative confirmation of the metallographic and hardness method of determining temperature is reported.

### PROGRESS

Note: Work in this quarter was considerably delayed due to moving of the metallurgical laboratories which are now in the process of being set up.



High Temperature Fatigue. Considerable progress has been made on the Henry High Speed Fatigue machine, using thesis students not connected with Project Squid. As the results are pertinent to our problems, they are being reported in some detail.

This machine is a resonance type device using the motion of permanent magnets past the specimen at controlled speed to induce resonant vibration of the specimen. Various specimens are being studied to determine which shape will be most suitable for high temperature work.

Figure 2. a, b, c, shows several types of beams that have been studied.

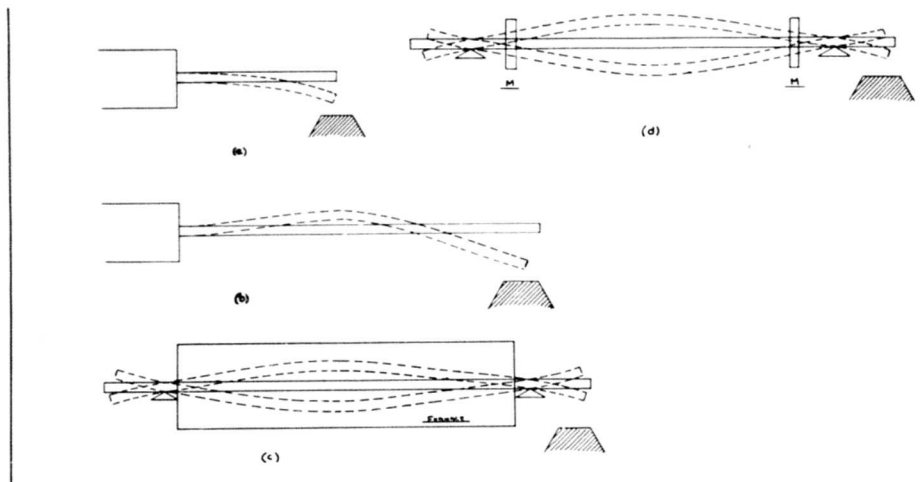

Figure 2.

Both 2a and 2b break at the vise, and therefore are difficult to adapt to high temperature study. By drilling a hole in 2a near the vise, it can be made to break away from the vise. However, the specimen is harder to tune, and high temperatures will increase this difficulty. 2c can break at the center or nodes. This specimen has many advantages, as it can be excited at its end or in the central part. It is also long enough to permit heating of the central portion for high temperature studies. A furnace is sketched in Fig. 2c to illustrate this point. Figure 2d is a modification of 2c to permit tuning, with the masses M, and also to confine failure to the center of the specimen. As yet, its characteristics have not been studied.

#### Tensile Type Tests

Modified Creep Machines. Work is continuing on the construction of two modified creep machines in which temperature will be varied while the load is applied. In one case a constant load will be applied and the elongation of the specimen will be observed. In the second case the specimen will be elongated at a constant strain rate, and the stress required to produce this constant rate will be observed.

Machine design has been modified several times to effect more simply automatic operation. The takeup nut is now motor driven and controlled by strain on a stress bar which acts as the loading system. It is expected that these machines will be operating and producing data soon.

High Temperature Extensometer. In connection with the above modified creep machines, extensometers are required. These are being built because conventional creep extensometers of the recording type operate satisfactorily in one direction only.

In Fig. 3a is shown our first extensometer, now nearing completion.

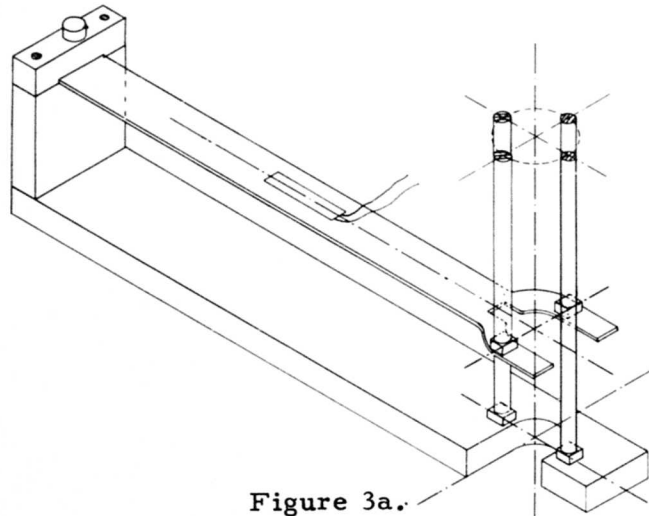

Figure 3a.

In this device the elongation of the specimen flexes a spring cantilever by means of the extension bars. The flexure of the cantilever affects an SR-4 strain gage mounted thereon.

In Fig. 4, a and b are two alternate circuits that can be used to record changes in the cantilever.

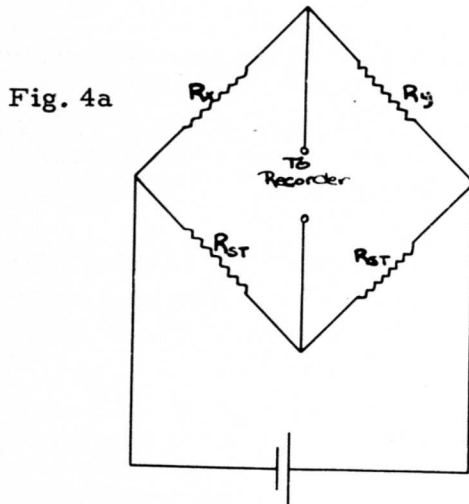

Fig. 4a

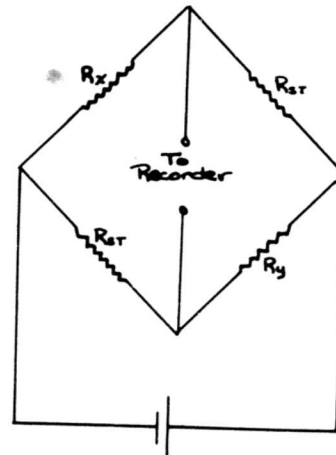

Fig. 4b

In circuit 4a the change of resistance in the pair of SR-4's ( $R_x$  and  $R_y$ ) is doubled, one gage being in compression and the other in tension. The  $R_{st}$ 's in the circuit are the reference standards. In circuit 4b changes are doubled but both gages are either in compression or tension. In each case the unbalance in a Wheatstone bridge circuit is recorded.

Calibration will be accomplished in an extension fixture. This will mechanically act as an elongating specimen except that the amount of extension will be known. The corresponding changes in millivolts will be recorded, and extension vs. millivolts plotted for the calibration.

In Fig. 3b is a proposed extensometer.

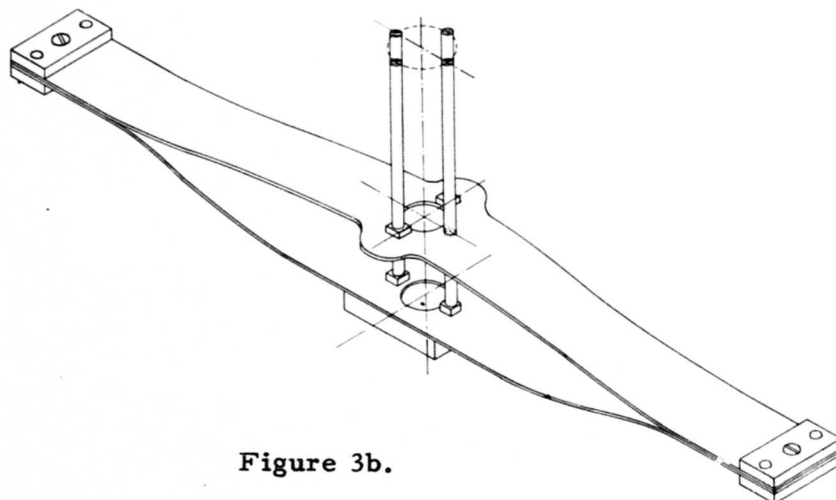

Figure 3b.

This design was developed to overcome several undesirable features of the extensometer shown in Fig. 3a.

In the new design, the extension rods will move in a parallel manner during the extension; while in Fig. 3a the motion is slightly non parallel due to the movement of the flexing cantilever through an arc. This last characteristic has been known all along. However, as this device is calibrated in terms of extension these errors should be overcome in the calibration.

Upon completion of testing of the 3a system, construction of the new extensometer will be undertaken.

Dilatometer. A simple dilatometer is being built for use in conjunction with these tensile tests. As the specimens are undergoing a changing temperature, a correction corresponding to normal thermal changes must be applied to the elongation observed.

Temperature Distribution Studies: Active work is now underway on this project.

Qualitative results are being reported here, which results are confirmed by Professor Morris Cohen and his co-workers who had other objectives in mind in their work on the tempering of high carbon steels. Ref. 1, 2, 3, and 4.

The method proposed for determining temperature distribution is as follows: Produce the machine or part to be studied of a suitable steel. Heat treat and quench to obtain a martensitic structure. The part will then be assembled and put into actual service. Operating temperature and time in service will temper the part, altering both the metallographic structure and the hardness. The temperature will be determined by comparison with a set of standards produced under known conditions. Time in the standards must be the same as the time in service.

An experiment to show the validity of this hypothesis was tried. A  $1/4"$  rod,  $2\ 3/4"$  long of high C steel (C - 1.35%, Mn - 0.52%, Si - 0.28%, S - 0.017, P - 0.006) was quenched in water after 15 minutes at  $1900^{\circ}\text{F}$ . This rod was then heated at one end by an oxy-acetylene torch, while the other end was in a water bath, thus producing a temperature gradient. Gradient was controlled by mounting a very light gauge thermocouple at the center of the specimen, temperature of  $600^{\circ}\text{F}$  being maintained at this point for 15 minutes. Temperature at the hot end reached an estimated  $1450^{\circ}\text{F}$  while the temperature of the water reached  $130^{\circ}\text{F}$ . The specimen was mounted in clamps in one piece, then wet ground to avoid any further tempering action. Longitudinal mounting was used so that temperature gradient could be observed metallographically. Mount was polished in one piece using optical emery. Etching was with 3% Nital. Eight points along the gradient were selected as per Fig. 5.

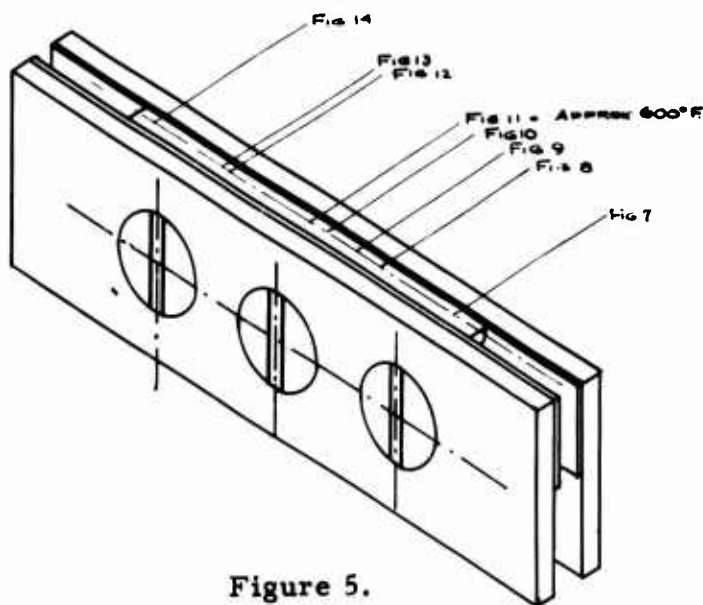

Figure 5.

Corresponding temperature and hardness determinations are shown in Figs. 6a and 6b.

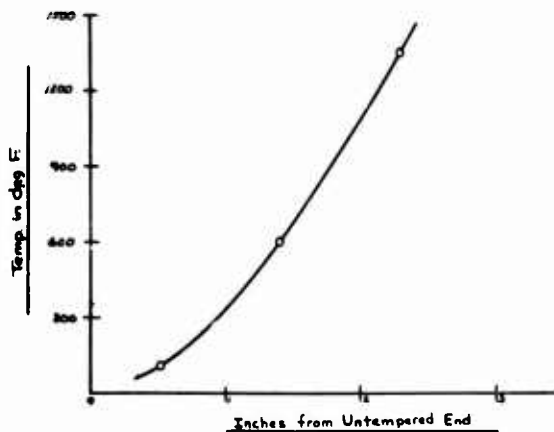

Figure 6a

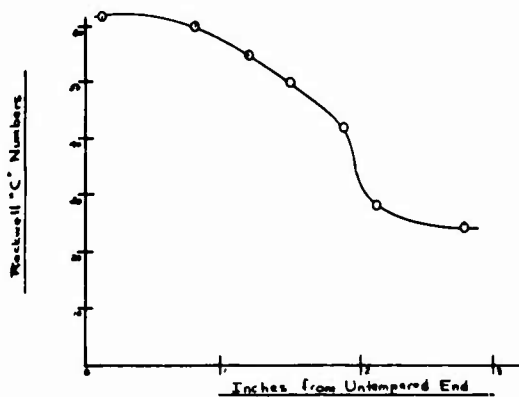

Figure 6b

Photomicrographs at 1000x for these points are shown as Figs. 7 through 14.

These hardness results and photomicrographic structures illustrate the qualitative validity of the method.

We are indebted to Professor Morris Cohen for the steel used in this qualitative work and for its analysis. This steel has many flaws and is probably unsuitable for accurate quantitative work. Three special H.C. steels are now on order for the quantitative program.



Figure 7.



Figure 8.



Figure 9.



Figure 10.



Figure 11.

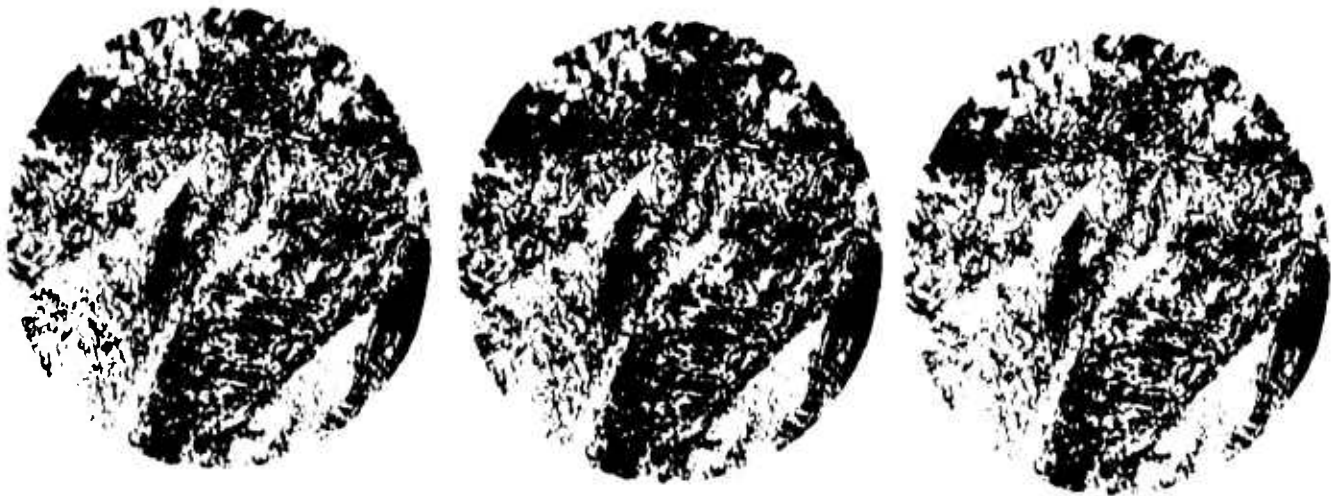

Figure 12

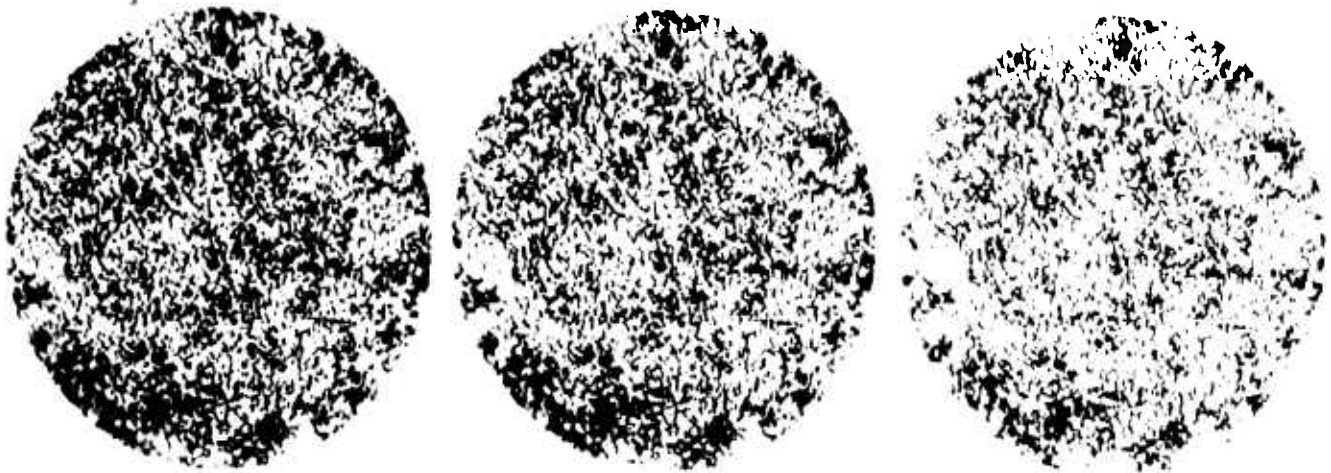

Figure 13.



Figure 14.

System Be-Cr. Investigation of the system Be-Cr has been stopped, due to moving of the laboratory and resultant damage to the Ajax furnace. The high frequency generator has been repaired and will soon be in operation. In the interval, library work has been continued.

Carbides and Nitrides. Literature study and some experimental work has been continued. Additional refractory metals for study have been ordered. Some study of the preparation of the carbides and nitrides that are not available has been initiated.

## REFERENCES

1. Tempering of Toolsteels (Part 1). Morris Cohen. Metal Progress, Vol. 51, #5, May, 1947. pg. 781-788.
2. Structural Changes during the Tempering of High Carbon Steel. Antia, Fletcher, Cohen. Trans. of the A.S.M. Vol. XXXII. 1944. pg. 290-332.
3. The Effect of Carbon on the Tempering of Steel. Fletcher and Cohen. Trans. of the A.S.M. Vol. XXXII. 1944. pg. 333-362.
4. Tempering of Nickel and Nickel Molybdenum Steels. Antia and Cohen. Trans. of the A.S.M. Vol. XXXII. 1944. pg. 363-380.

## PHASE NO. 3

(a) To investigate the metallurgical, fabrication, and design problems involved in cooling rocket and intermittent jet motors by the diffusion of fluids through porous metal combustion chamber liners. (b) To study analytically and experimentally (1) the diffusion of fluids through porous media under high pressures and temperatures and (2) the effects (of this diffusion) on the internal aerodynamics. (c) To study problems in the field of physical chemistry pertinent to (a) and (b) with consideration given to the clogging of pores, the use of catalysts imbedded in the liner walls, and endothermic diffusion processes.

## SUMMARY

A theoretical investigation of the laminar boundary layer flowing along a porous flat plate with a fluid injected through porous cells of the plate was made. Temperature distributions in this boundary layer were calculated for different values of the Prandtl number. Wall temperatures on the hot gas side can be determined from the above results in terms of the ratio of injected coolant velocity and stream velocity for a given hot gas temperature  $T_i$ , and coolant temperature  $T_o$ .

## PROGRESS

The theoretical study of the aero-thermodynamic problems involved was started by the investigation of the flow of a hot gas over a porous flat plate under the condition of uniform gas injection from the bottom of the plate. The momentum equation and the corresponding energy equation for the boundary were set up with the velocity of injection assumed to be uniformly distributed along the plate.

In the solution of the laminar layer equation, the momentum and energy equations were reduced to the integral relation form similar to the Karman integral relation of the Prandtl equation. The velocity and temperature profiles were assumed as a polynomial of the fourth degree in exponential forms. Since the velocity at the boundary layer is constant for the flow over a flat plate, linear differential equations for the boundary layer and the direction of flow, i.e.  $F(\sigma)$  and  $F(X)$ , were obtained and solved. The results of the solution are shown in Figs. 15 and 16.



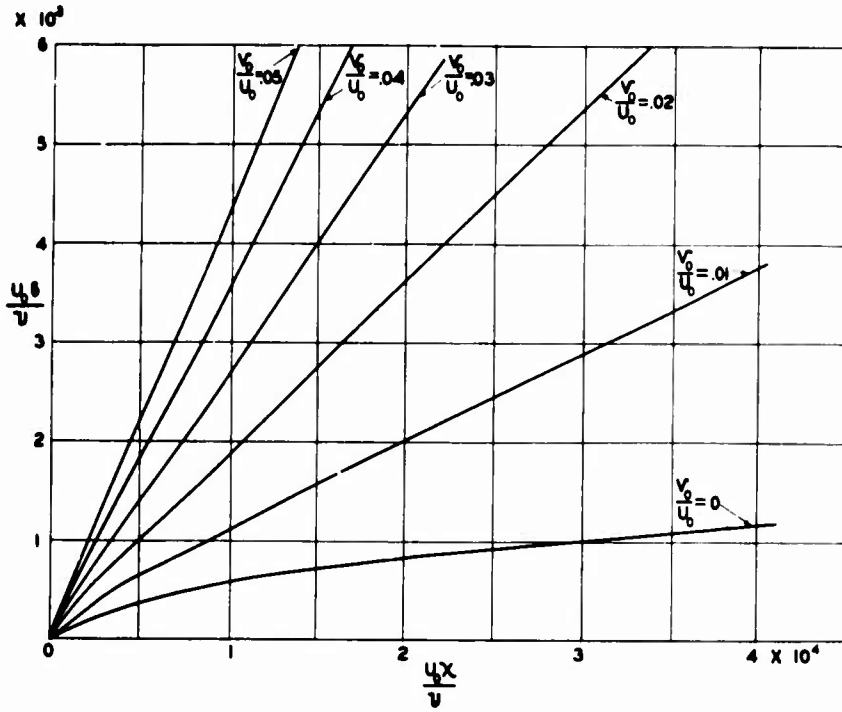

Figure 15.

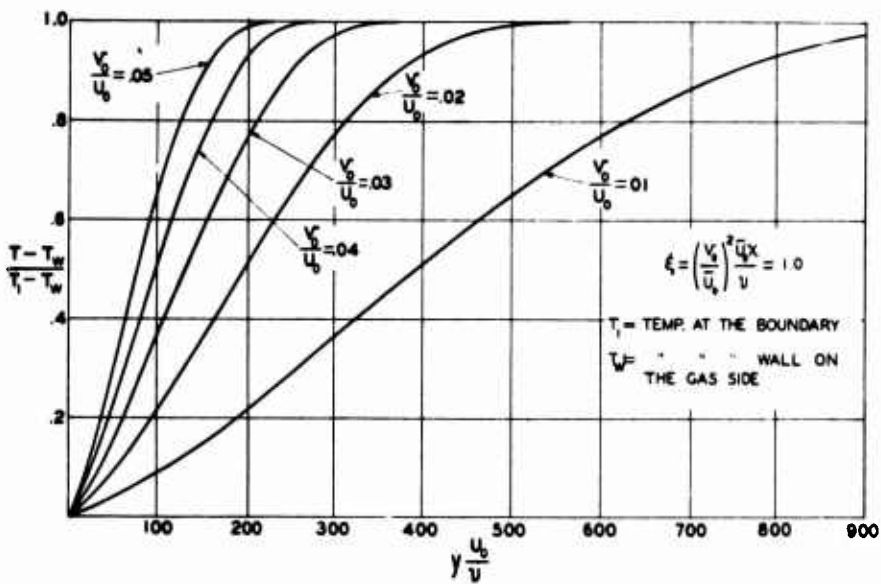

Figure 16.

Since the relation between  $F(\delta)$  and  $F(x)$  are linear (except in the neighborhood of the leading edge of the plate) a constant ratio,  $\xi$ , was assumed for the temperature layer  $\delta_t$  and the velocity layer  $\delta$ . This ratio is independent of the distance  $x$  in the direction of flow. With this assumption the temperature distribution in the boundary layer was obtained in terms of  $R_x = \frac{u_0 x}{\nu}$ ,  $\frac{\nu}{u_0}$ ,  $\xi$  and the Prandtl number. Temperature profiles were plotted at various  $\frac{\xi}{u_0}$  ratios.

From the condition that the quantity of heat removed by the plate per unit area is equal to the quantity of heat absorbed by the coolant per unit area, a relation between the wall temperature and the amount of coolant needed can be established. This relation is shown in Fig. 17 for various Reynolds numbers.

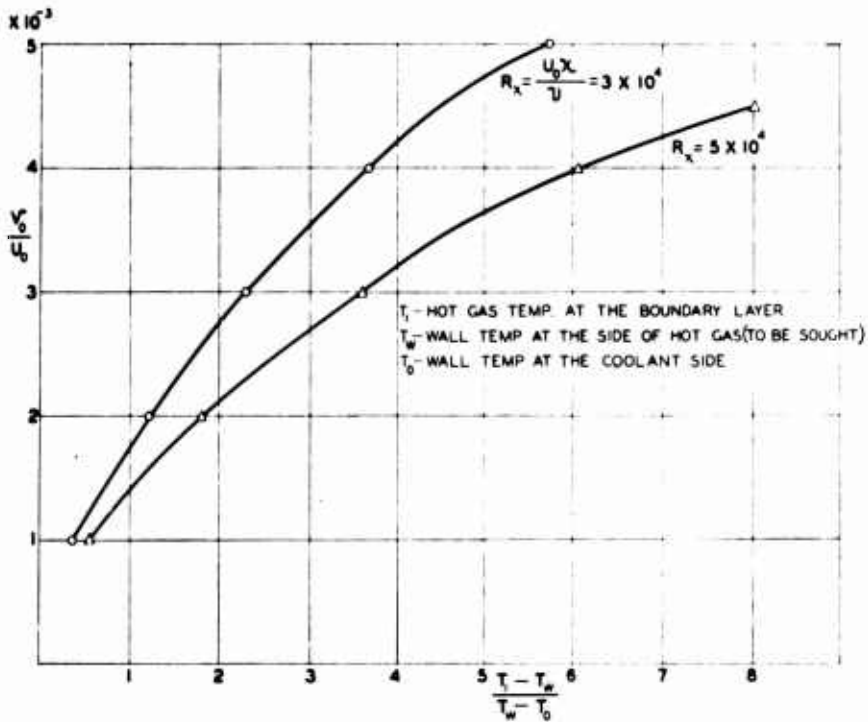

Figure 17.

The above analysis was based on an incompressible fluid, i.e., the mass density and viscosity of the fluid were assumed to be constant. The analysis for a compressible fluid in which the mass density and viscosity are functions of the temperature is underway.

## PLANS

Fundamental experiments on laminar boundary along a porous flat plate with fluids injected through porous cells were discussed with Dr. Duvez, Dr. Rannil, and Mr. Thiel at the JPL/CIT. The growth of a boundary layer along the direction of flow, and the location of the laminar separation are especially interesting. The purpose of these experiments is to verify the theoretical investigation and establish some fundamental theory for the flow along a porous surface, rather than to obtain the immediate applications.

QUARTERLY PROGRESS REPORT

1 July 1947

PROJECT SQUID

Purdue Research Foundation  
and  
Purdue University  
Lafayette, Indiana  
Navy Department Contract  
N6ori-104, Task Order I

## PHASE NO. 1

Development of a method of measuring instantaneous gas temperatures fluctuating at frequencies from 50 to 100 cycles per second in a range of temperatures from room temperatures to 3000°F. (pulse jet gases).

### SUMMARY

The survey of the available literature at Purdue University has been completed. Apparatus has been designed and tested for detecting, amplifying, observing, and recording the electrical impulses from thermocouples. Special welding techniques have been developed for fabricating small-wire thermocouples.

### DISCUSSION

Because of several factors that have been discussed in previous reports, the experimental staff decided to limit the study to the measurement of gas temperatures by means of thermocouples. It is recognized by the investigators that the problems involved in the possible use of thermocouples for measuring the temperatures of gases under transient conditions are many and perhaps unsolvable. However, for engineering use, the advantages of a system based on a thermocouple are obvious. It may be possible to devise a satisfactory system employing thermoelements that may not measure the actual temperature, but that, with suitable correction factors, may be used to determine the temperature within plus or minus 10 per cent. This type of system would find wide use in engineering design. The investigators, therefore, elected to proceed along this line of development work. The progress of the work is discussed in the paragraphs that follow.

### PROGRESS

(1) A survey of the literature available to the research staff at Purdue University has been completed.

Methods and apparatus used for measuring the temperature of gases flowing at subsonic and supersonic velocities have been studied.

(2) The thermocouple, the emf chopper, the amplifier, and the photographic recorder have been constructed and tested, and the operation of the equipment has been found to be quite satisfactory. A report covering this part of the work has been submitted.

(3) Several types of thermocouples have been constructed, and preliminary tests conducted. Various techniques for welding very fine wire have been developed. This part of the work is being continued in order that better couples may be obtained. An apparatus is being designed so that the response of very-fine-wire thermocouples may be determined.

### PLANS

The work dealing with the study of the response of small thermocouples will be continued.

## PHASE NO. 2

To study continuous process combustion, defining the effects of combustion-chamber size and shape, fuel and oxidizer distribution, and turbulence with available fuels and oxidizers.

**SUMMARY**

During the period covered by this report activities have been concentrated on four phases, namely: (1) the creation and measuring of turbulence in a small Bunsen-type burner and observation of the effects of turbulence on combustion; (2) investigation of the factors involved in flame-holding devices and the study of a flame holder of radical new design; (3) modification and improvement of the intermediate-sized burner previously referred to as a small-scale burner; (4) continuation of planning, procuring, and construction of equipment and facilities for large-scale combustion studies.

**PROGRESS**

Because of hazardous operating conditions, research on the intermediate-sized burner has been kept to a minimum until the new building is available at the Purdue University Airport. Work on the Bunsen-type burner has been expedited to determine the possible relationship between turbulence and rate of flame propagation in the combustion process.

The designation, "Bunsen-type", is really a misnomer, since the only purpose served in this case by the Bunsen burner is the mixing of gas and air before introduction into the contracting-jet nozzle which serves as the burner. This can be seen in the accompanying sketches, Figures 1 to 3 inclusive.

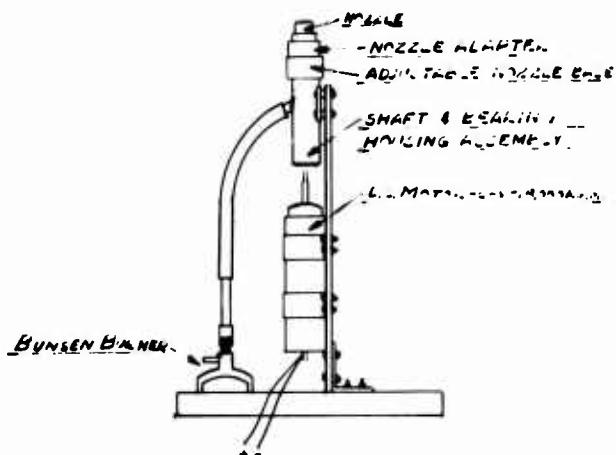

Figure 1.

Rotating Rod Turbulence Creator Assembly

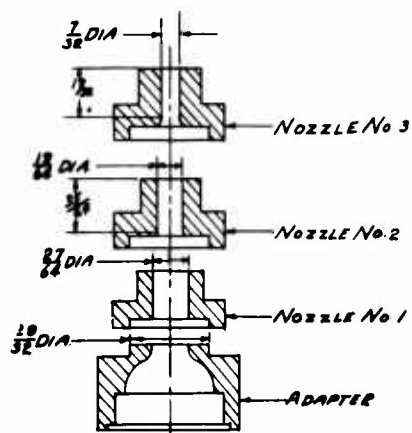

Figure 3.  
Rotating Rod  
Turbulence  
Creator  
Nozzles

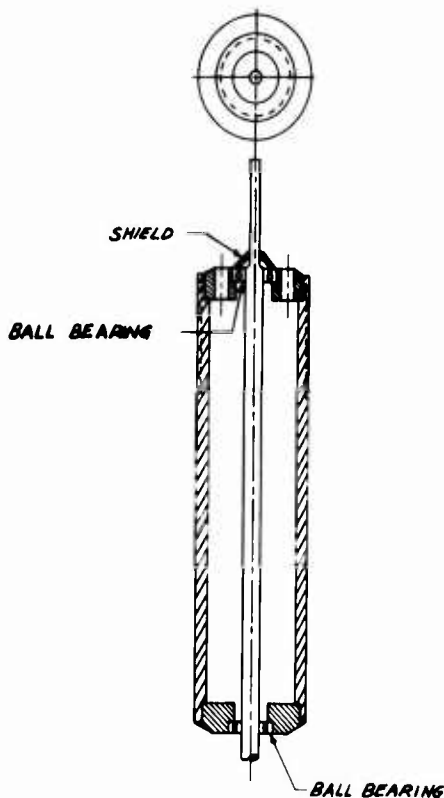

Figure 2.

Rotating Rod Turbulence Creator  
Shaft and Bearing Housing Assembly

The gaseous fuel and air, after mixing in the Bunsen burner, are supplied to the housing (Fig. 2) which serves the dual purpose of supporting the high-speed bearings for the rotating shaft and mount for the nozzle adapter. The latter is adjustable in an axial direction and supports the various types and sizes of nozzles (Fig. 3). The adjustable feature permits study to be made of the relationship of the rod-end position with respect to the nozzles on the flame configuration. The variable-speed motor permits operation at any speed between zero and 18,000 r.p.m.

Observation of the change in the inner cone of the flame with changing shaft speed indicated a rather pronounced effect. The cone changed from the usual geometric shape of a cone with a slightly rounded tip to one having the upper portion inverted within the lower portion of the cone. The inverted tip could be made to assume a definite position with respect to the nozzle discharge end when stable operation was attained.

A hot-wire anemometer, built in accordance with National Advisory Committee for Aeronautics Technical Note TN 990 by Dr. J. Weske, was used to determine the effect of the speed of the rotating-rod turbulence creator on intensity of turbulence and velocity gradients across the discharge of the nozzle. There was good indication of the relationship existing between the intensity of turbulence, velocity of mixture, and flame front. Figure 4 shows the distribution of velocity of mixture, and flame front. Figure 4 shows the distribution of velocity and turbulence intensity in a line of a plane parallel with the burner axis.

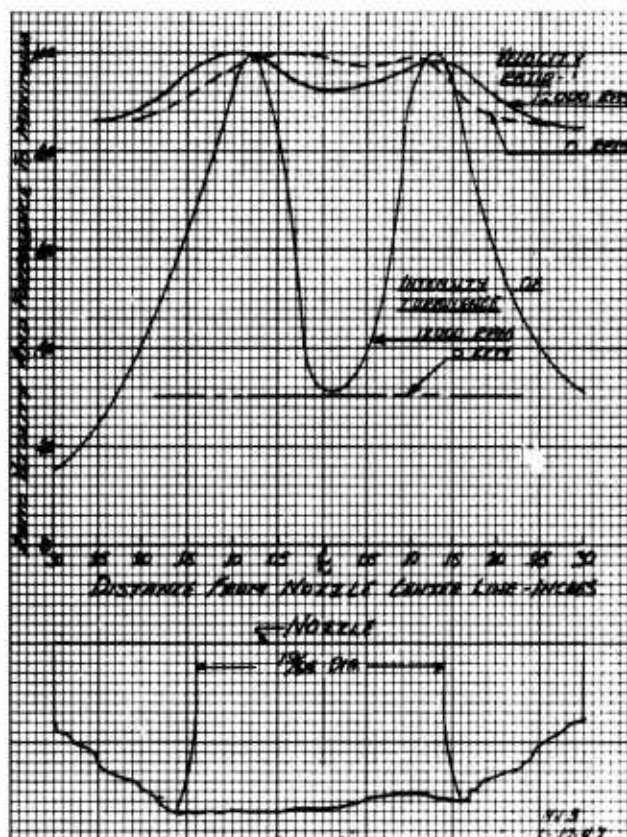

Figure 4

Effect of Rotating Rod on gas velocity and intensity of turbulence in contracting jet nozzle.

It can be seen that the ratio of turbulence intensity to the maximum value reaches a maximum just inside the extension of the nozzle bore. The radial position at which this peak value occurs changes with the distance of the line of traverse above the nozzle. The minimum value of turbulence intensity occurs at approximately the center line of the nozzle and at a region considerably beyond the bore of the nozzle. The existence of an isotropic turbulence is indicated by the broken line showing a nearly constant level of intensity when the rod is stationary. The survey was not extended to determine the place at which the intensity of turbulence for zero r.p.m. would decrease, but it is probably that it would occur in a region closer to the center line of the nozzle than at 12,000 r.p.m.

It is of interest that the velocity peaks are at about the same points as the intensity of turbulence. The slight dip in the velocity curve for zero r.p.m. is expected, because of the rod location. Also, the peaking of the velocity can be seen to occur closer to the center line than is the case at high speed. The slight vortex created by the rotating rod would tend to create this difference.

No attempt has been made as yet to correlate the measurements obtained with the flame-propagation velocity. The work of Guoy<sup>1</sup> and more recently that of Damkohler<sup>2</sup>, and of Garside, Forsythe, and Townend<sup>3</sup>, will be followed to see if it is possible to use the inner cone area of the flame to obtain burning velocity. The sharply defined configuration observed for the inner envelope under turbulent conditions may permit empirical formulation of relationship.

Figure 5 shows a sketch of the flame-holding contracting nozzle and its relation to the mixing chamber, the propane supply nozzle, and the retracting ignition system.

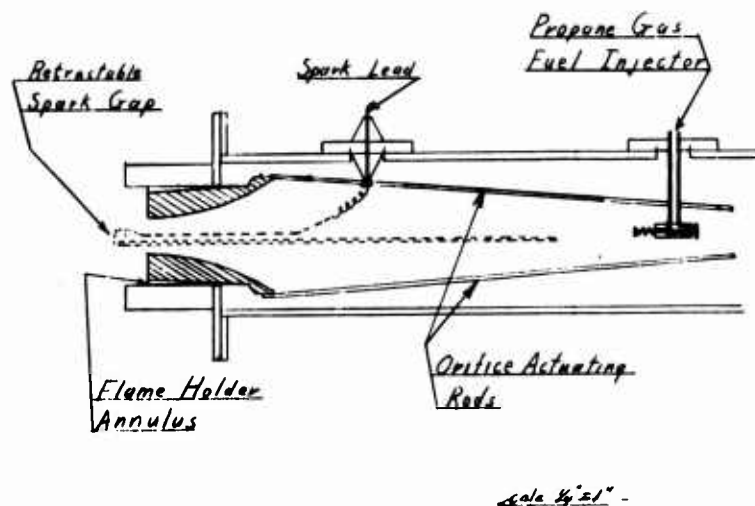

Figure 5. Installation of flame holder

1. M. Guoy. *Annales de Chemie et de Physique*, Series 5, Vol. 18, pp.27-35 (1879)
2. G. Damkohler. "The Effect of Turbulence on the Flame Velocity in Gas Mixtures", NACA TM 1112.
3. J. Garside, J. Forsyth, and D. Townend. "The Stability of Burner Flames" Institute of Fuel, August 1945, p. 175

This nozzle consists of two members with a conical annulus formed between. Positioning ribs are on the outside of the inner member to retain exact radial position. The extremely small angular difference between the two members which form the annular passage is designed to obtain extreme ranges of mixture velocity through the nozzle and yet, by means of the reduced velocity in the annulus to retain the flame. The position of the flame front in the annulus would move axially until the flame-propagation burning rate equals the velocity of the gases in that portion of the annulus. A retracting device is also available for positioning the inner member to allow study of the effect of the area at the entrance to the annulus on permissible velocities in the throat of the nozzle before flame retention fails.

Although only one run has been made up to this time, the results have far exceeded expectations. Mixture velocities of 300 feet per second have been reached in the nozzle throat with no indication of the occurrence of flame blow-off. Higher velocity will be attempted as soon as a larger by-pass around the compressor can be incorporated to eliminate the surging which has prevented study of the effect of high-mixture velocities. Furthermore, it will be necessary to confine combustion within a chamber, instead of permitting burning in the atmosphere, to ascertain definitely the possible benefits of this device. Previous experiments have indicated that greater velocities can be obtained when combustion is confined.

Rapid progress is being made on the construction of the combustion laboratory. It is anticipated that occupancy will be possible in July and the experimentation started before fall. All the various systems required for the operation of the engines and superchargers have been fabricated; however, the final assembly will require appreciable time. Fabrication of air-supply ducts of suitable capacity presents a major problem.

## PLANS

Plans for the immediate future call for the continuation of experiments with the Bunsen-type burner and parallel work with the intermediate-sized burner, as well as the investigation of flame-holding devices.

## PHASE NO. 3

This phase undertakes the study of corrosion in connection with jet propulsion. The purpose of the research is to identify the corrosion products, and to investigate the process of corrosion as affected by the chemical and physical properties of the materials and the conditions of exposure.

## SUMMARY

The oxidation of an 18-chrome-steel has been investigated by x-ray methods at 775°C and 900°C. At both temperatures the oxide first formed is rich in chromium; but, as the oxidation proceeds, the percentage of chromium in the oxide decreases, whereas the absolute amount of chromium remains essentially constant, an indication of the formation of a protective layer of high chromium content. Both the percentage of chromium in the oxide and the absolute amount of chromium are greater at the higher temperature. The initial oxide layer is probably of a structure intermediate between  $\text{Fe}_2\text{O}_3$  and  $\text{Cr}_2\text{O}_3$ , tending toward the former as the layer thickness increases.

An electron diffraction camera suitable for experimentation at high temperatures has been developed.



A systematic investigation of binary and commercial heat-resistant alloys is outlined. Two new methods of examining the distribution of the components in alloys and in the oxide layers are proposed.

## PROGRESS

The x-ray investigation of the oxidation of 18-chrome-steel has been continued. The absorption method of analysis previously reported (1 April 1947) has been applied to oxide layers too thin for satisfactory analysis by their diffraction patterns. In this method the weakening of a base metal diffraction line by absorption in the superimposed oxide layer is compared for two radiations,  $\text{CuK}\alpha$  and  $\text{FeK}\alpha$ , which lie at wavelengths on either side of the characteristic absorption discontinuity of iron. It has been established that the ratio of the two absorption coefficients so found is a calculable function of the percentage of chromium in the layer and nearly independent of the state of oxidation. After determination of the percentage of chromium present, the percentages of iron and oxygen that will give agreement with the two observed absorptions simultaneously may easily be found. The total weight of oxide and the weight of each constituent can then be computed.

Recently, a second method of reducing the observed data has been found, which gives the amount of iron in the oxide layer without the use of trial calculations or assumptions concerning the nature of the layer. The x-ray absorption coefficients of all elements are known to vary (between characteristic discontinuities) proportionally with the cube of the wavelength of the radiation. Hence, it is possible to compute, from the measured weakening of the two radiations used, what intensities would be found for the two wavelengths (essentially coincident) on either side of the iron characteristic discontinuity and adjacent to it. The ratio of these intensities depends only on the amount of iron in the layers; the absorption due to any other element cancels out. The values obtained by this interpolation method are shown in parentheses in Table I.

The results of oxidation of 18-chrome-steel in oxygen at one-atmosphere pressure at temperatures of  $775^{\circ}\text{C}$  and  $900^{\circ}\text{C}$  are shown in Table I. At the higher temperature a loose scale was formed in addition to an adherent scale. This loose scale was removed and analyzed separately. In this case the absolute values (marked \*) depend upon an estimate of the ratio of the area of collection of sample to the area of the specimen prepared for measurement, and are not as reliable as the relative values.

It is evident, at both temperatures, that the initial oxide is rich in chromium and that the percentage decreased with increasing time. Over the range of time as shown, the actual amount of chromium in the adherent layer approaches a constant value, and the increase in total adherent oxide is due to the addition of iron oxides. This implies that a protective layer of a fairly definite composition is built up and that iron diffuses outward through the layer at a greater rate than does chromium. The chromium that does penetrate goes into the loose scale, while part of the iron forms adherent scale. It will be noted that the initial percentage, and also the absolute amount, of chromium involved in this layer are considerably greater at the higher temperature than at the lower temperature. Since the initial chromium enrichment of the oxide must be at the expense of local chromium impoverishment at the alloy surface, the diffusion rate of chromium in the alloy must increase more rapidly with temperature increase than does the rate for iron. The experiments will be extended to include other samples and for longer periods of time in order to find how general these trends may be.

It has been possible to obtain some x-ray diffraction patterns of these layers. For the thicker ones there is very little, if any, deviation from the structure of  $\text{Fe}_2\text{O}_3$ . From the compositions given, 20 to 27% chromium, one should expect some devia-

tion of the patterns toward the similar but slightly different one of  $\text{Cr}_2\text{O}_3$ . Stoichiometrically, the intermediate pattern of  $3\text{Fe}_2\text{O}_3 \cdot \text{Cr}_2\text{O}_3$  is highly probable, but there is little positive evidence of its presence. For the layers with the higher percentages of chromium, there is some evidence for the existence of the oxides intermediate between  $\text{Fe}_2\text{O}_3$  and  $\text{Cr}_2\text{O}_3$ . The Phillips recording spectrometer is not suitable for this work, since the only radiations available are strongly absorbed in these chromium-iron samples. Diffraction work is therefore being continued on other instruments in which CrK and MoK radiations may be used, with the resultant higher precision of the measurements made.

The vacuum furnace for oxidation and investigation of the surface structure of samples in the electron diffraction camera, without intervening cooling, has been finished and completely tested. It has been used successfully up to temperatures of  $650^\circ\text{C}$ . A routine program of experiments with this equipment has begun.

The optical and electron microscope examination of cross sections through oxidized surfaces has been successful for heavy layers on low-chrome alloys. A definite layering structure has been found. Efforts to improve the technique and extend it to the harder alloys is continuing. Binary alloys for systematic investigation of the effects of composition and conditions of exposure on the oxidation process have been received and preliminary measurements made, but the materials in the "as cast" form show too much dendritic formation to be satisfactory. Heat treatment and working are now being carried out to affect homogenization and grain refinement.

## PLANS

A program of investigation of the binary alloys available will be undertaken as outlined. The outlined program, in part, will be extended to include certain commercial heat-resistant alloys.

1. Preparation of sample. Examination of surface before and after heat treatment and polish.
2. Exposure to corroding atmospheres (oxygen, dry and moist, air, etc.) at various temperatures and pressures for increasing periods of time.
3. Examination of the corrosion layer.
  - a. Optical and electron microscopy - surface and in section.
  - b. X-ray microradiography - surface and in section.
  - c. Determination of corrosion products by x-ray, electron diffraction, microscope, etc.
  - d. Determination of thickness and rate of growth.
  - e. Steps (1) and (3) combined in the electron diffraction camera, possibly also in x-ray methods.
  - f. Electrical and physical measurements pertaining to the protective nature of layers.

In reference to 3-b, wherein the purpose is to obtain the distribution of components in the oxide layer, two additional methods are being investigated.

It has been found (J. J. Trillat, private communication) that segregations may be identified as follows: A fine-grain photographic plate is put in contact with the surface and irradiated with 200 K.V. x-rays. There is sufficient differential in the efficiency of release of photoelectrons to produce an image on the plate, the blackness of which is characteristic of the type of atom present.

The second method contemplates irradiation of the surface with suitable chosen x-rays so that the photoelectrons are released with energies characteristic of the type of parent atom. By means of an electric or magnetic lens, an enlarged electron image of the surface can be formed with electrons of each of these energies, to give a direct photograph of the corresponding distribution of the atoms.

TABLE I

## OXIDATION OF 18-CHROME-STEEL BY OXYGEN AT ONE-ATMOSPHERE PRESSURE

Sample	Temp., °C.	Time, Hrs.	Nature of Oxide	Cr, %	mg/cm <sup>2</sup>		
					Total Oxide	Cr	Fe
2	775	10	yellow-brown, adherent	26	0.38	0.10	0.167 (0.178)
	775	10 + 10	yellow-brown, adherent	24	0.69	0.165	0.317 (0.316)
	775	10+ 10 + 10	yellow-brown, adherent	79	0.78	0.151	0.397 (0.393)
1b	900	1	rough, gray-brown, adherent	42	0.744	0.312	0.208 (0.194)
	900	1 + 4	gray-brown, adherent, loose scale	21	0.765	0.101	0.375 (0.35)
1c	900	1	gray-brown, adherent and loose gray scale	45	0.53	0.238	0.13 (0.08)
	900	1	after removing loose scale	45	0.434	0.195	0.108 (0.10)
	900	1 + 4	gray-brown adherent and loose gray scale, after removing loose scale	27	0.87	0.235	0.373 (0.34)
900			the removed scale	20	0.94*	0.189*	0.47*(0.465)*
	1 + 4 + 5	gray-brown adherent and loose gray scale, after removing loose scale	17.8	1.30	0.232	0.678(0.665)	
		the removed scale	18	1.46*	0.263*	0.76*(0.763)*	

\*Absolute values depend on an unreliable estimate of the ratio of the area of collection of the sample to the area of specimen prepared for measurement.

## PHASE NO. 4

### STATEMENT OF PROBLEM

The purpose of this research is to study, by means of bomb or continuous-flow experiments, temperatures, pressures, and concentration of reactants for various oxidation reactions of materials that may be of value for a rocket or a jet engine.

### SUMMARY

Equipment is being assembled for the study of the oxidation of hydrazine or perhaps hydrazine hydrate by air-oxygen mixtures and possibly by pure oxygen and pure hydrogen peroxide. The preliminary experiments will be carried out in a constant-volume bomb, and the investigation will be limited to the non-explosive region.

### PROGRESS

The apparatus will consist of a pyrex reaction vessel attached to vacuum pumps, charging vessels, a manometric system and a constant temperature bath, as shown schematically in Figure 6.

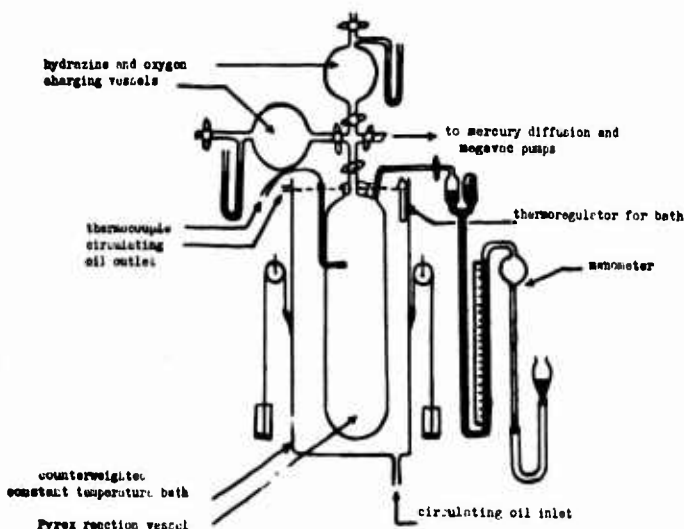

Figure 6.

The apparatus will be designed to permit the study of the effect of the varying of the surface to volume ratio on the rate of both the oxidation reaction and the thermal decomposition of hydrazine or hydrazine hydrate, in order to determine the rate of the reaction of the homogeneous or heterogeneous system, as may be the case. No chemical analyses will be made during these first runs, except the analysis of the final products at the end of the reaction period. After the initial studies have been made, a new reactor will be constructed with facilities for removing micro-samples during the course of the reaction by means of a Toepler pump arrangement. This will permit the study of several variables, such as concentration of reactants, temperature, and pressure in an effort to determine the mechanism of the oxidation reaction.

## PLANS

The plans for the immediate future call for the completion of the construction of the equipment, after which data will be obtained on the rate of pressure rise with time for the oxidation of hydrazine or hydrazine hydrate as carried out in the static system.

## PHASE NO. 5

The purpose of this research is to determine, for liquid-fuel rockets and pulse jet engines, the radiation factor and its contribution to heat-transfer coefficients inside a pipe with gas flow at low and also at high temperatures.

## SUMMARY

The assembly and installation of equipment are about complete. The carbon dioxide absorber, the water-vapor absorber, and the rotameter were completely installed during this quarter. The temperature controller was partially installed and construction of the electric preheater and test section was initiated. Trials of the gas-fired furnace at maximum temperatures proved satisfactory.

## PROGRESS

Considerable progress was made during this period in the assembly and installation of equipment. The soda-lime absorber and the silica-gel absorber were constructed and installed for the removal of carbon dioxide and water vapor, respectively, from the laboratory air supply. The air, thus purified, is to be used in the first test runs in the determination of convection coefficients of non-radiating gases, which are to be used in predicting the convection coefficients of radiating gases in later phases of the work.

The rotameter to be used in measuring the gas flow rates was received and installed. The mechanism for controlling the gas temperatures entering the test section was received in part and has been installed as completely as possible.

Approximate maximum gas temperatures attainable from the gas-fired pre-heater were determined for working mass rates of flow. Several arrangements of the baffles were tried in the furnace until one was found that allowed the nichrome heating coil to reach its maximum operating temperature of 2100°F. Under these conditions, the exit gas reached a maximum temperature of 1520°F. at a flow rate of 10 cubic feet per minute (corrected to standard conditions). As these results are slightly better than the design figures, the furnace is considered satisfactory.

A modification of the plans for the test section was found necessary when it was learned that the 2-inch nichrome pipe for the test section originally ordered in January, will still be unavailable for several months. As a temporary expedient, 2-inch nichrome tubing has been procured for both the electric heater and the test section. This construction is now under way.

## PLANS

It is hoped that construction of the apparatus will be completed during the next quarter. After that, a considerable amount of time will be spent in perfecting the thermocouple arrangements.

## PHASE NO. 6(F)

The purpose of this research is to determine experimentally the heats of formation and combustion, the specific heats, and other thermodynamic properties of various fuels and oxidizers used in pulsating jet engines. If possible, a correlation of thermodynamic properties of these fuels will be made, so that calculations may be extended to include new fuels.

### SUMMARY

An adiabatic calorimeter using a modified Emerson oxygen-bomb calorimeter and a Daniels adiabatic-jacket has been assembled and is ready for calibration. Upon completion of the calibration experiments, the heats of combustion of selected substances suitable as fuels and oxidizers in pulsating jet engines will be determined. Two substances are available and are awaiting purification.

### PROGRESS

The greater part of the time during the past quarter has been spent on assembling the equipment for determining heats of combustion. The calorimeter assembly to be used for this work is a modified Emerson oxygen-bomb calorimeter equipped with a Daniels adiabatic-jacket. To approach adiabatic conditions, the temperature of water in the outer jacket is maintained at the same temperature as the weighed quantity of water in the calorimeter can, by passing a current of electricity through the jacket water during the time combustion is taking place.

The difference in temperature between the calorimeter water and the jacket water will be visually indicated by means of a differential Copper-Constantan thermopile connected to a Rubicon spotlight galvanometer. The thermopile to be used will contain sufficient elements to approach adiabatic conditions within  $0.01^{\circ}\text{C}$ . difference between the temperature of the two water baths. The electrical energy for the heater in the outer water jacket will be controlled by means of an automatic photocell relay control unit. The temperature rise of the weighed quantity of water in the calorimeter can well be measured by means of a Beckman differential thermometer calibrated by the Bureau of Standards. The temperature rise may be measured to  $\pm 0.001^{\circ}\text{C}$ . by using an ordinary magnifying lens, or to about  $\pm 0.0005^{\circ}\text{C}$ . by using a more elaborate magnification system. All of the equipment has been delivered and assembled except the photocell relay unit to be used for controlling the current to the heater in the outer water jacket. The combustion and absorption tubes for purifying the oxygen supply to the bomb have been assembled and are ready for use. The calorimeter assembly will be calibrated by using standardized benzoic acid obtained from the Bureau of Standards, and the methods of comparative measurements will be followed. Eight to twelve calibration runs will be made before beginning experimental determinations of selected compounds. Calibration runs will be made at intervals thereafter in order to check the performance of the apparatus.

Samples of three materials (dinitropropanes) have been obtained with which the heats of combustion are to be determined after the equipment has been calibrated. These samples are in the impure form and will be purified before any experimental determination.

## FUTURE PLANS

Calibration of the equipment will start within the next few weeks. After the equipment has been calibrated, it is planned to determine the heat of combustion for one or two compounds of which the heat of combustion is already known in order to check the equipment and the technique employed. The work will then be directed toward determining the heat of combustion of the selected three samples and certain additional compounds which will be prepared this summer.

### PHASE NO. 6(G)

The subject of the research on Phase No. 6(G) is the determination of heats of combustion of various chemical compounds suitable as high-energy fuels and oxidizers.

### SUMMARY

Combustion experiments with methyl nitroacetate have been continued and many of the problems encountered in the ignition of this compound have not been completely solved. Selection of other compounds to be examined is being continued along with a study of methods by which the selected material may be purified. One of the compounds selected for heat-of-combustion determination is 3-nitro-p-toluidine.

### PROGRESS

The report of progress on this phase of Project SQUID includes (1) modification and improvement of the apparatus, (2) the beginning of combustion experiments with methyl nitroacetate, (3) the selection of further compounds, including 3-nitro-p-toluidine, of which the heats of combustion will be determined, and (4) the procurement and purification of some of these compounds.

It became apparent to the investigators during the past few months that, with the advent of hot, humid summer weather, it would be necessary to shield the apparatus in order to reduce stray electric currents. To this end, the thermels, the heater circuit, and the ignition system have been shielded; the galvanometer and the battery systems will be shielded as soon as the remainder of the material needed is received. Improvements to eliminate "drift" in the audible interval-timer were made. The addition of a heater with a greater temperature range improved the temperature control of the air bath. The double-valve Parr oxygen bomb was received, as well as the weights needed for use with the large balance. These weights were calibrated before use.

Early in the establishment of the research program it had been decided to determine the heats of combustion of three metal-organic compounds which were to be furnished by Aerojet Corporation. When these compounds failed to arrive, it was decided to postpone consideration of these compounds, and attention was directed instead to methyl nitroacetate, an oxidizer which has found use in rocket fuels under development at Purdue University. This compound was purified, and combustion experiments were begun.

The ignition of this compound is a problem that has not been satisfactorily solved. The use of combustion promoters has been successfully tried but promoters will not be used except as a last resort, because methods utilizing them are less precise. Because of the extreme hygroscopic nature of methyl nitroacetate, it is necessary to place the sample within a glass ampoule. When enclosed in glass ampoules, the compound is difficult to ignite because the glass breaks so slowly that the ignition wire is consumed before the sample is completely burned. Some success has been obtained with two-necked flattened-sphere ampoules. Work is continuing on the problem of obtaining ampoules fragile enough to break easily when the ignition wire burns.

The compound 3-nitro-p-toluidine has been investigated and seems to be adaptable to our method of measurements. A sample of 40 grams of 3-nitro-p-toluidine (Eastman Kodak Company) has been purified by being recrystallized three times from aqueous ethyl alcohol and finally sublimed. The resulting sample of 10 grams will be checked for purity and its heat of combustion determined. From theoretical calculations of the expected heat of combustion, samples of about 1.1 grams will be required for each determination.

#### PLANS

Future work will consist of measuring the heats of combustion of selected substances, especially those suitable as high-energy fuels.



QUARTERLY PROGRESS REPORT

1 July 1947

PROJECT SQUID

Cornell Aeronautical Laboratory  
Buffalo, N. Y.  
Navy Department Contract  
N6ori-119, Task Order I

## PHASE NO. 1

In connection with pulsating jet engines: to undertake theoretical and wind-tunnel investigations on flows and losses in diffuser inlets, diffusers, intake valves, exhaust nozzles, and thrust-augmenting ducts for subsonic and supersonic pulsating jets.

### SUMMARY

The study of gas flow in half-open pipes was brought to a temporary conclusion and the analytical relations obtained were assembled in a preliminary report. A report was also prepared on the electrical analogy of gas waves of large amplitudes. Work on the hydrodynamical model experiments is now being started, and the arrangement to measure gas densities by means of light absorption in a smoke filled atmosphere has been completed. The motion of shock waves in supersonic diffusers with periodically varying boundary conditions was studied both theoretically and experimentally.

### PROGRESS

*Start*  
*is*  
*done*  
*done*  
*planned*  
*study?*

The study of gas flow in half-open pipes yielded a number of analytical relations showing the influence of the shape of the pipe on infinitesimal oscillations and the additional effect of finite amplitude. In view of the very simplifying assumptions which had to be made, the results have to be treated with caution until experimental proofs become available. A preliminary report on this work has been prepared. Experimental checks will be based on measurement of the transient gas density in pipes which are filled with air at higher-than-ambient pressure and which are suddenly opened at one end. Addition of smoke will increase light absorption sufficiently to make photoelectric measurements possible. Both ammonium chloride and titanium-tetrachloride seem to be suitable. However, it might not be possible to fill the whole pipe uniformly with smoke and in this case measurements will have to be restricted to the region near the closed end. The experimental arrangement has been completed, and tests will start as soon as the cathode-ray oscillograph which is on order is delivered. Gravity surface waves on water will also serve to test the theoretical results, and work on the design of the setup for this experimentation has been started.

The study of the electrical analogy of gas flow led to the conclusion that the approach considered would not be practicable. A report on this work was prepared. No further work will be done on this problem unless a more promising approach can be found.

Testing of the two-dimensional supersonic diffuser with controlled, periodically varying back pressures was continued in an attempt to determine the effects of frequency and amplitude of such pressure fluctuations upon the instantaneous shock pattern and the range of travel of the normal shock inside the diffuser. The pressure was controlled by means of a butterfly valve, rotated by an electric motor drive.

High-speed striae motion pictures were made of the wave pattern, at 1000, 2000, and 3000 frames per second, while the valve was operating at 5000 r.p.m. In order to detect any effect of the tunnel boundary layer on such patterns, the tests were conducted with and without removal of this boundary layer. A report describing the experimental procedure and summarizing the results of the tests conducted so far, is being prepared.

## PLANS

The analogy experiments of gravity surface waves on water and gas flow in pipes will be undertaken soon. It is also planned to investigate the Bodine free-piston type pulse jet, following a suggestion by the Navy Bureau of Aeronautics. Preliminary experiments replacing the piston by the membrane of a loudspeaker indicate that such a system develops measurable thrust at a certain frequency. When the pipe is filled with smoke, a definite jet forms at that frequency. Further study of this phenomenon by means of stroboscopic observation and theoretical treatment based on the method of characteristics is planned.

The theoretical and experimental study of unsteady flow in diffusers will be continued. The investigation will be extended to cover the cases of shrouded pulse jet diffusers and of diffusers of pulse jet shrouds.

## PHASE 2

In connection with pulsating jet engines: to study the theory of combustion, effect of turbulence on flame propagation and cooling, and to verify and augment existing theories by means of experimental investigation of ignition, combustion, flame holding, flame propagation, and cooling.

## SUMMARY

The work on the combustion chamber with the magnetically driven spark has been temporarily discontinued because a strike is still preventing Indiana Steel Corporation from delivering the magnet. A new electronic flame speed recorder to be used in combination with ionization gaps or other detecting systems for the study of flame propagation in pipes has been designed and is under construction. It has not yet been possible to use this device for the measurement of flame speeds, because of a delay in the delivery of the required oscillograph.

A study of flame propagation under turbulent conditions was undertaken, following a novel method of approach. A laminar Bunsen burner flame is disturbed by means of an alternating electric field or sound waves. Both frequency and intensity of these disturbances can be measured and varied. Photographs of the disturbed flame front can be used to measure its surface and to study the mechanism of propagation of particular types of disturbances. These experiments led to the discovery of an electric flame holding effect.

A burner and its instrumentation have been installed for the purpose of investigating the possible catalytic influence of combustion chamber wall material. The design of this apparatus is essentially described in the previous Quarterly Report. In trial runs in Inconel, 4130 steel, and 304 stainless steel tubes, only vague evidence of broadening of the flame front with increased fuel in-put has been obtained. The data more nearly coincide with the behavior to be expected, if the concept of instantaneous burning in a narrow flame front was in effect.

Some work has been done toward the development of methods for measuring the amount of heat release in combustion and its time factors.

The preparatory work for the first issue of the Instrumentation Bulletin was completed and plans were made by the Instrumentation Panel for future organization of this work. A report was prepared on the previous study of the required frequency response of pressure pickups for pulse jets.

## PROGRESS

During the first experiments with the ionization gaps to measure flame propagation velocities it became clear that the gaps did not become deionized quickly enough to make the position of the oscillograph trace steady. To eliminate this effect, definite pulses were introduced in the oscillograph by an electronic device. A circuit was designed which will trigger the single sweep each time the flame reaches one of the gaps. The length of the trace depends then on the time required for the flame to travel between the gaps. In addition, succeeding sweeps are slightly displaced vertically from each other, so that consecutive traces are separated. Timing will be achieved by modulation of the beam intensity. This instrument may be built for any desired number of ionization gaps. A trial circuit is now being built. Other flame detection methods, such as the Calcote detector developed by Princeton University, are also being studied. Although much more elaborate than the simple ionization gaps, the Calcote detector may be useful in checking whether ionization gaps interfere with flame propagation in any way.

The problem of flame propagation under turbulent conditions was attacked by means of an indirect approach. It was felt that the deformation to which a flame front is subjected in a turbulent flow is too complicated to allow a quantitative investigation of the phenomena involved. In order to investigate flame fronts distorted in a simpler way, a study of Bunsen burner flames subjected to periodical disturbances was started. It is hoped that this method will allow a check on the assumptions upon which present theories of flame propagation in turbulent streams are based, and will provide information for modifying and improving the theory.

Alternating electrical fields and sound waves were chosen as means for creating the disturbances. The electrical field is applied between the metallic burner nozzle and a spherical electrode located close to the outer flame cone. The acoustical disturbances are created by means of a loudspeaker. The flame is observed through a stroboscopic disc. Synchronism of the disturbance with the disc was found indispensable for photographic registration of the flame pattern. It was achieved by deriving the voltages fed to the loudspeaker, or to the high voltage transformer, from the amplified output of a photoelectric cell exposed to a light beam interrupted by the disc. A standing wave pattern appears on the surface of the distorted inner flame cone observed through the stroboscope. Measurements of the wave lengths of the patterns indicate that the disturbances travel upwards along the cone with a velocity approximately equal to the streaming velocity of the gas. Area measurements of the distorted cone surfaces are now under way, which so far seem to confirm the theoretical prediction that the burning velocity is independent of amplitude, phase, and frequency of the disturbance, for constant mixture composition.

While investigating the influence of a. c. fields on flames, it was observed that the blow-off limit of Bunsen flames was raised by the field. The same effect was also observed with d. c. fields if the nozzle was made the negative electrode. An increase of the gas flow velocity at blow-off by a factor of two could be achieved with the highest fields obtainable. The upper limit was reached when sparking at the electrodes set in. A technical report covering this investigation is being prepared.

A 6" x 4" engine was designed and built, to be used as a working pulse jet model for exploratory experimentation and as a test vehicle for reed designs and materials.

Difficulties were encountered in obtaining proper fuel-air mixing for satisfactory operation. In general, commercial fuel nozzles (which have been tried in numerous arrangements) did not appear to be satisfactory for internal fuel injection. Other methods for internal fuel injection are being investigated.

Commercial fuel nozzles located outside of the combustion chamber upstream of the intake valve spraying directly into the intake valve gave good performance. With such a configuration, a fuel specific impulse of over 1000 seconds was realized in static operation.

A burner and its instrumentation have been installed for the purpose of investigating the possible catalytic influence of combustion chamber wall material. The burner is comprised of a 1/2" tube (only metals have been tested to date) which is insulated on all sides by at least 10" of Sil-O-Cel. A flame arrester, composed of numerous stainless steel discs, was located in the tube and adjusted so that the flame front would fall well within the insulated zone. Through a small side arm welded to the tube just downstream from the flame arrester, an igniter and a flame holder were inserted. Beginning at the flame arrester, thermocouples were attached to the outer surface of the tube at 2" intervals on the upstream half of the tube and 3" intervals on the downstream half of the tube. These were used to record the gas temperature in lieu of a thermocouple probe, because calculations had shown that a probing thermocouple would read essentially the wall temperature when used under the empirical condition in the burner, namely, a narrow tube operating at equilibrium conditions.

A pre-mixed fuel was supplied through a series of valves so that a wide variation in gas velocity could be obtained for any given air/fuel ratio. A hydrocarbon gas, Natoxoline, which is essentially propane, and compressed air were individually metered through the burner. This fuel supply was sufficiently versatile so that wide variations in the air/fuel ratio and in the total amount of fuel supplied to the burner could be rapidly varied.

Numerous tests have been run in the Inconel burner. The wall temperatures at various positions along the tube have been recorded and plotted against tube length. Plotting these temperatures in this manner produce a graph which rises sharply to a maximum and then gradually recedes. As the velocity increased, the position of maximum temperature moved downstream. No broadening of the maximum temperature zone was observed.

Various types of flame holders have been introduced into the burner to hold the flame at a fixed point and, thus, to facilitate broadening of the area of maximum temperature. The flame holders were either metal or refractory. Cylindrical, conical, and hemispherical shapes were tried. A wire coil was also tested, as was a cylindrical flame holder in which an acetylene pilot light was inserted. None of these have proved successful, for the maximum temperature zone still moved downstream with increased fuel input. A cylindrical porcelain flame holder with a cross section similar to that of a capital D, was used as a standard for further tests.

Tests were run in which the air/fuel ratio was maintained constant and the fuel input was gradually increased. A family of curves, wall temperature versus tube position, was plotted. The initial slope of each member of the family was nearly the same. This indicates that instantaneous burning of the gas is taking place and that end effects are being introduced by the downstream end of the tube. The position of maximum wall temperature was a function of gas velocity.

Maintaining the air/fuel constant also did not increase the area of maximum temperature nor did it retard the change in position of the maximum temperature as the velocity was increased.

Next, tests were run in which the gas velocity and the air/fuel ratio were held constant in an attempt to establish full equilibrium over the length of the tube, as well as to broaden the zone of maximum temperature. A thermocouple was inserted in the Sil-O-Cel refractory material surrounding the burner tube. This thermocouple was placed 1-1/4" from the wall of the tube at a position of maximum temperature. The test was run for 2-1/4 hours during which readings were taken every 1/4 hour. After two hours the increase in temperature recorded at the thermocouple imbedded in the Sil-O-Cel was negligible and the downstream thermocouples were also essentially constant. Increasing the length of time of the test did not increase the area of maximum temperature nor did it produce any appreciable change in the type of curve previously obtained.

The 2-1/4 hour test was repeated at a higher velocity and again no favorable results were obtained. The results at a higher velocity were similar to those previously discussed, except that the zone of maximum temperature could not be held at a fixed point. With all conditions held constant, the position of maximum temperature slowly moved downstream.

A 4130 steel 1/2" diameter burner tube was constructed and tested. However, the tube burned out before any data could be recorded.

A 304 stainless steel 1/2" diameter burner tube was constructed and tested. The results obtained were very similar to those obtained with Inconel.

Some work has been done on the development of methods for measuring the amount of heat release in combustion and its time factors. The exact efficiency of a water cooled sampling tube in freezing the dissociation reactions of CO<sub>2</sub> and H<sub>2</sub>O has been masked by the difficulties encountered in establishing a satisfactory equilibrium mixture of either of these gases. Previously reported attempts to establish an equilibrium for CO<sub>2</sub> were only partially successful. Hence, it was planned to eliminate the troubles by using a new high temperature apparatus. The essential part of this apparatus is an impervious ceramic U-tube which can be heated above 2700° F. Such a tube has been ordered, but delays in its delivery have prevented further experimental efforts.

Contributions for the first Instrumentation Bulletin were collected, and at a meeting of the Instrumentation Panel in New York on 16 June, a sample issue was assembled. This, together with recommendations for the editing of future issues, was submitted to the Technical Committee.

#### PLANS

The application of striae and shadow techniques to the work on burner flames is planned, and the necessary equipment has been ordered. Extension of the range of frequencies of the disturbances to values corresponding to wave lengths of the order of the thickness of the flame front is contemplated. In addition to flames seated on the nozzle, lifted flames, either burning freely in the gas stream or held by a flame holder, will be investigated.

#### PHASE NO. 3

In connection with pulsating jet engines: To undertake experimental investigation of temperature- and fatigue-resistant materials for intake valves and coatings, and of fabrication methods and techniques to cover said materials.

## PART I - VALVE MATERIAL STUDY

### SUMMARY

Preliminary tests on the fatigue machine revealed some difficulties of operation which necessitated redesigning the machine and furnace for heating the specimens. The new machine has proven satisfactory. Further testing is delayed pending arrival of materials and parts.

### PROGRESS

The pneumatic-resonant fatigue machine has been redesigned and constructed. The new machine eliminates the difficulties encountered in the use of the old design. Suitable adjustments were incorporated so that the nozzles can be adjusted vertically and rotated about a horizontal axis. These adjustments allow the nozzles to be aligned with the specimen regardless of the amplitude. Difficulties were also encountered with the use of the resistance wound furnaces. The nichrome wire that was used has an operating temperature limit of 1800° F. In order to obtain this temperature in the furnace chamber, the elements must be at a considerably higher temperature. It was decided, therefore, to construct a furnace which will utilize Globars as a heat source. The furnace is built and will be tested as soon as the Globars arrive.

Lack of auxiliary equipment is still the major source of delay. The electronic tachometer has been received and the only other large piece of equipment that is needed is the temperature controller.

A small Dyna-Jet model airplane power plant has been run for temperature determinations on the materials. The Dyna-Jet was obtained with the thought that valve materials could be evaluated in actual operating conditions. This was found to be impractical, due to the design difference involved.

### PLANS

It is planned to start testing specimens of high temperature materials as soon as the complete unit is assembled. Curves will be established for temperature versus fatigue life (amplitude constant for different materials) and amplitude or stress versus fatigue life (temperature constant). From these curves and data accumulated from high temperature tensile tests, a correlation between high temperature tensile strength and high temperature fatigue life should become apparent for each given material. Materials will also be compared with each other as to fatigue life at high temperature.

## PART II - HIGH TEMPERATURE METALLOSCOPE

### SUMMARY

Improvements have been found necessary on both of the original designs of furnaces, one of which was heated by induction and the other by resistance elements. Delivery of the optical equipment is the primary cause of delay at present.

## PROGRESS

The original microscope stage furnace heated with a resistance winding proved to be difficult to evacuate because of the gases that were absorbed and occluded in the refractories. A new design was constructed in which all refractory insulation was placed outside the evacuated chamber. This design eliminates the above difficulty and will attain temperature up to 2000° F. The design for use with induction heating has also been improved and is now being constructed. The brass top is being ground to match the tapered seal on the glass bottom. Temperatures up to the melting point of the metal should be possible with this type of furnace.

Some of the glassware for the vacuum system has arrived but the bulk of the auxiliary equipment is still undelivered. Delivery is expected on all items within the next sixty days.

## PLANS

It is planned to start experimental work as soon as the optical system arrives and is assembled. The resistance furnace will be used, and studies will be made of common metals, such as steel and aluminum, at comparatively low temperatures (800° F to 1500° F). When the technique is properly worked out, studies will be extended to high temperature alloys at elevated temperatures. The induction heated furnace should be available by this time.



QUARTERLY PROGRESS REPORT

1 July 1947

PROJECT SQUID

Princeton University  
Princeton, N. J.  
Navy Department Contract  
N6ori-105, Task Order III

## THE OFFICE OF THE PROJECT ORGANIZER

This office has the responsibility under the Policy Committee for the overall coordination and management of Project SQUID. In addition, the Technical Survey Group of this office has been undertaking certain technical work and technical liaison duties.

### FIELD SURVEY REPORT

The preparation of this report has been conducted by Engineering Research Associates, Inc. under a subcontract with Princeton University and is described under Task Order No. 2 with that organization.

### SPECIFIC PROBLEM

Engineering Research Associates, Inc., shall prepare a Field Survey Report concerning the technical fields relating directly and indirectly toward the development of liquid rocket and pulse jet engines. This report shall contain a detailed review of all existing work sponsored by Government agencies at the present time with a detailed presentation of the work with respect to cost, personnel and facilities, with consideration for related research projects in support of the specific development and production activities. Upon completion of this report and the assembly of these data, the finished draft shall be submitted to Princeton University for printing.

### SUMMARY

During this quarter the Technical Survey Group made up of ERA and Princeton personnel has visited additional research facilities to complete the information necessary for preparing the Field Survey Report. Rough drafts of each part of the survey report were prepared during April and May; where possible these were checked for accuracy with the government contractors reported on and with authorities in each field for guidance on the presentation of the material. Following numerous staff conferences with the Princeton members of the Technical Survey Group, the final form of the report was firmly established during May. Final drafts of each part were prepared and submitted to Princeton on 16 June 1947. These were reviewed by members of the Policy Committee or their designated representatives. The changes suggested by these reviewers are now being incorporated into the report. All of the corrected parts will be ready for editorial review by Princeton not later than 16 July; these will be forwarded immediately for printing. Arrangements are now being made for the selection of the printer.

## PHASE NO. 1

In connection with liquid rockets and pulsating jet engines; to investigate theoretically and experimentally

- (1) the stability of laminar boundary layer,
- (2) the interaction of boundary layer with external flow field at supersonic velocities as it affects pressure distribution around bodies of revolution, airfoils, etc., and
- (3) interaction of shock waves in channels and diffusers.

### SUMMARY

Construction of the supersonic wind tunnel has been started and considerable effort is being devoted to this assignment.

Theoretical investigations are under way considering the problem of non-steady flow in a tube with heat addition.

### PROGRESS

Equipment and Building Alterations. Alterations to the old Concrete Testing Laboratory were completed. Concrete foundations were installed for the two Worthington compressors and the driving motors, and this equipment was moved onto its foundations. The electrical contractor has assembled all necessary equipment, and work on the electrical installation is expected to begin shortly. Work has begun on the erection of the concrete platforms to which the air bottles will be bolted.

Major details concerning the regulator-reducing valves and piping layout and fittings have been settled with the contractors.

Two professional draftsmen are now employed full-time on the detailed design of the wind tunnel proper.

Optical Apparatus and Instrumentation. The Naval Gun Factory has made considerable progress on the fabrication of the plates for the 4" interferometer. The tunnel "windows" are first being finished to schlieren quality, but it is planned to re-finish the "windows" to interferometer quality next year.

Schlieren apparatus and light sources for both large and small tunnels have been ordered. Some thought is being given to detection of oxygen and nitrogen condensation in the supersonic nozzle by means of light scattered by the liquid droplets behind the condensation shock. Such observations would supplement the schlieren photographs.

Several concerns have submitted detailed specifications of sensitive pressure gauges, and these specifications are being studied. Particular attention is being paid to the problem of measuring the low pressures over the upper surface of the test airfoils at high Mach numbers and high angles of attack. (Theoretical calculations of the airfoil pressure distributions are now in progress).

Pilot Tunnel. A considerably more desirable location for the Pilot Tunnel has been found at one end of the horizontal firing range. The detailed layout of the tunnel is completed, and a contractor selected who will fabricate the piping, fittings, and settling chamber. The reducing-regulator valves have been ordered and should be delivered in a month.

## THEORETICAL STUDIES

Non-steady Flow in a Tube with Heat Addition. A theoretical study is in progress to determine the physical phenomena that occur when heat is suddenly added to a section of a straight tube in which a gas is flowing with uniform velocity. The analysis is based on the Riemann equations for plane wave propagation, with the heat addition terms retained. These equations are integrated numerically by the method of characteristics.

Of particular interest is the mechanism by which a new steady flow is established when sufficient heat is added to "choke" the original flow. When the phenomena are better understood, the methods developed in the present investigation will be applied to the processes in the pulse jet tube. It is hoped that the problem of a suitable model for the flame motion, and therefore the heat addition, can be attacked with the aid of recent experimental data.

### PHASE NO. 2

To study (1) the characteristics of combustion in high velocity fuel-oxidant streams, ignitibility, efficiency, after-burning, thrust, etc., (2) effects of sub-atmospheric pressures, (3) interactions between ionization and flame, (4) observation of optical and mass spectra, and (5) theory of adiabatic exothermic reaction.

This phase is jointly sponsored with U. S. Bureau of Ordnance APL-JHU associated contract number NOrd-7920, Task PRN-3.

### SUMMARY

Experimental and theoretical investigations are under way on burning velocities in Bunsen-type burners.

Further work has progressed on addition agents as igniters for hydrocarbon vapors.

Work has been undertaken on the development of new instrumentation for flame measurements.

### PROGRESS

Experimental and theoretical work to date has been concerned with burning velocities in Bunsen-type burners which are shielded to prevent access to external air. Feed rates are limited to the equivalent of Reynolds numbers below 2000 (laminar flow). It appears that burning velocities are mainly determined by the rate of back-diffusion of atoms and radicals from the flame front. As a first approximation the linear flow velocity,  $u$ , to the flame front, which is equivalent to the burning velocity, can be written

$$u = \left( \frac{k C c_o D}{Q} \right)^{\frac{1}{2}}$$

where

$k$  = a reaction rate constant;

$C$  = average concentration of reactant;

$c_o$  = calculated equilibrium concentration of atom or radical in the flame front at flame temperature;

$D$  = coefficient of diffusion of atom or radical into unburned gas;

$Q$  = amount of fuel or oxidant (whichever is less) in unit volume.

Since hydrogen atoms diffuse most easily, they are of greatest importance. Calculations indicate a general dependence of burning velocity on the square root of hydrogen atom concentration as required.

The effect of reducing the pressure is of interest. Experiments indicate an increase in burning velocity within a limited range of pressure. This is attributed to the increase in diffusion coefficient,  $D$ , which over-balances the decrease in H-atom concentration.

Substitution of helium for the nitrogen of air triples the burning velocity for hydrocarbons. This is due mainly to the higher H-atom concentration, which in turn depends on the higher temperatures achieved on substitution of helium with a lower heat capacity.

Attempts are being made to ignite hydrocarbon vapors in air by means of addition agents. Boron tri-ethyl vapor will ignite a butane-oxygen mixture. However, a liquid mixture of boron tri-ethyl and pentane would not ignite when sprayed into air. Aluminum borohydride vapor will also ignite a butane-oxygen mixture provided there is moisture present.

Two types of flame detectors have been devised. In one of these the change in loading characteristics of a tank coil circuit on passage of the flame in a glass tube is used to trigger a timing circuit. In the other, two strips of aluminum foil are wound around the glass tube. One strip is connected through a 7 megohm resistance to one side of a 700-volt power supply. The other side of the power supply and the other strip are grounded. Passage of the flame produces a pulse (presumably due to ionization) which again triggers the timing circuit.

Work is also going forward on optical spectra; and in addition the utility of a helium-detecting mass spectrograph is being investigated.

FORM NO. 1 (10 FEB 47)

U.S. Navy Dept.

DIVISION: Guided Missiles (1)

SECTION: Production (10)

CROSS REFERENCES: Missiles, Guided - Production -  
Design (63250); Squid (63250)

ATI- 13568

ORIG. AGENCY NUMBER

REVISION

AUTHOR(S)

AMER. TITLE: Project Squid - Quarterly progress report, 1 July 1947

FORG'N. TITLE:

ORIGINATING AGENCY: U.S. Navy Department, Washington, D.C.

TRANSLATION:

COUNTRY	LANGUAGE	FORG'N. CLASS.	U. S. CLASS.	DATE	PAGES	ILLUS.	FEATURES
U. S.	Eng.		Unclass.	Jul'47	54	36	photoe, tables, diagre, graphe

ABSTRACT

Work on all phases of Project Squid showed much progress during the period covered by this report. Field tests were scheduled to begin shortly. New machines have been developed to aid the research program, along with new instruments to observe and record all types of data. Many conclusions are drawn from the theoretical and experimental analyses, and some phases of work have progressed far enough to permit drawing up of preliminary reports.

DISTRIBUTION OF THIS REPORT IS LIMITED. COPIES CAN BE OBTAINED ONLY THROUGH TSEPP-9, AIR MATERIEL COMMAND, WRIGHT FIELD.

T-2, HQ, AIR MATERIEL COMMAND

Air TECHNICAL INDEX

WRIGHT FIELD, OHIO, USAAF

DTIC-0-11 MAR 47

EDITION (B K 07)  
New York Univ.

DIVISION: Guided Missiles (1) 25  
SECTION: Production (10) 4  
CROSS REFERENCES: Missiles, Guided - Development (62920); Combustion - Rate of flame propagation (23650); Missiles, Guided - Ground handling (62950)

ATI- 13569  
ORIG. AGENCY NUMBER  
REV. 5

AUTHOR(S)

AMEL. TITLE: Project Squid - Quarterly progress report, 1 July 1947

FORG'N. TITLE:

ORIGINATING AGENCY: New York University, New York.

TRANSLATION:

COUNTRY	LANGUAGE	FORG'N. CLASS.	U. S. CLASS.	DATE	PAGES	ILLUS.	FEATURES
U.S.	Eng.		Unclass.	Jul '47	15	12	photos, graphs

#### ABSTRACT

Where data have become available, as in the moving flame studies, satisfactory results have been achieved. Because much of the future work will be done in field tests, the test equipment and facilities of many kinds are being mounted in mobile units which have recently been acquired. This equipment includes an electronic instrumentation trailer, a power and air supply truck, a shop truck, a blower trailer, a general field trailer, and a trailer mount for the JB-2 pulse jet.

DISTRIBUTION OF THIS REPORT IS LIMITED. COPIES CAN BE OBTAINED ONLY THROUGH TSEPP-9, AIR MATERIEL COMMAND, WRIGHT FIELD.

T-2, HQ., AIR MATERIEL COMMAND

AIR TECHNICAL INDEX

WRIGHT FIELD, OHIO, USAAF

17-0-21 (MAR 47)

TITLE: Project Squid - Quarterly Progress Report - 1 July 1947 25 →

AUTHOR(S) : (Not known)

ORIG. AGENCY : Polytechnic Institute of Brooklyn, Brooklyn, N.Y.

PUBLISHED BY : (Same)

ATI- 13570

REVISION

(None)

ORIG. AGENCY NO.

(None)

PUBLISHING NO.

(None)

DATE	U. S. CLASS	COUNTRY	LANGUAGE	PAGES	ILLUSTRATIONS
July' 47	Unclass.	U.S.	English	14	photos, diagrs, graphs, drwgs

ABSTRACT:

Theoretical analysis of inflow through periodically moving reed valves has resulted in a general solution for the hinged-type valves. A method for determining the temperature on the hot gas side of a porous plate with a fluid injected through the porous cells of the plate has been found, and it is felt that this method, which depends on the injected coolant velocity and the stream velocity, will aid in the study of the cooling of reaction motors.

DISTRIBUTION: Copies of this report obtainable from CADDO.

DIVISION: Power Plants, Jet and Turbine (5)  
SECTION: Combustion Chambers (12)

SUBJECT HEADINGS:

Combustion - Thermodynamics (23659)  
Materials - Thermal properties (60500).  
Project Squid (75406); Valves, Reed (96319)

ATI SHEET NO.:

Central Air Documents Office  
Wright-Patterson Air Force Base, Dayton, Ohio

AIR TECHNICAL INDEX



TITLE: Project Squid - Quarterly Progress Report, 1 July 1947

AUTHOR(S) : (Not known)  
ORIG. AGENCY : Purdue University, Lafayette, Ind.  
PUBLISHED BY : (Same)

ATI- 13571

REVISION  
(None)

ORIG. AGENCY NO.  
(None)

PUBLISHING NO.  
(None)

DATE	U. S. CLASS	COUNTRY	LANGUAGE	PAGES	ILLUSTRATIONS
July '47	Unclass.	U.S.	English	13	table, graph, drwgs

ABSTRACT:

Apparatus has been designed and tested for detecting, amplifying and recording of the electric impulses from thermocouples. The effects of combustion-chamber size and shape, mixture distribution, and turbulence on continuous process combustion have been studied. It has been found that the oxide layer in jet engines is essentially chromium. Experimentation in the oxidation of fuels is being conducted. A study of the radiation factor as related to jet engines is ready to be started.

DISTRIBUTION: Copies of this report obtainable from CADO

DIVISION: Power Plants, Jet and Turbine (5)  
SECTION: Combustion Chambers (12)

SUBJECT HEADINGS:  
Combustion chambers (23883)  
Thermal measurement (93486)  
Project squid (75406)

ATI SHEET NO.:

Central Air Documents Office  
Wright-Patterson Air Force Base, Dayton, Ohio

AIR TECHNICAL INDEX

FORM 69 (13 MAR 47)

Cornell Aeronautical Lab.

DIVISION: Power Plants, Jet and Turbine (5)

SECTION: Combustion Chambers (12)

CROSS REFERENCES: Combustion - Rate of flame propagation (23650); Thermal measurement (93500)

ATI- 13572

ORIG. AGENCY NUMBER

REVISION

AUTHOR(S)

AMER. TITLE: Project Squid - Quarterly progress report 1 July 1947

FORG'N. TITLE:

ORIGINATING AGENCY: Cornell Aeronautical Lab., Buffalo, N. Y.

TRANSLATION:

COUNTRY	LANGUAGE	FORG'N. CLASS	U. S. CLASS.	DATE	PAGES	ILLUS.	FEATURES
U.S.	Eng.		Unclass.	Jul'47	7		

## ABSTRACT

The study of gas flow in half-open pipes was concluded, and results prepared in a preliminary report. A study of flame propagation under turbulent conditions was undertaken. Some work has been done towards the development of methods for measuring the amount of heat release in combustion and its time factors. Preliminary tests on the fatigue machine revealed some difficulties of operation which necessitated redesigning the machine and furnace for heating the specimens.

TITLE: Project Squid - Quarterly Progress Report, 1 July 1947

AUTHOR(S) : (Not known)  
ORIG. AGENCY : Princeton University, Princeton, N.J.  
PUBLISHED BY : (Same)

ATI- 13573

REVISION

(None)

ORIG. AGENCY NO.

(None)

PUBLISHING NO.

(None)

DATE	U. S. CLASS	COUNTRY	LANGUAGE	PAGES	ILLUSTRATIONS
July '47	Unclass.	U.S.	English	5	(None)

ABSTRACT:

Construction of a supersonic wind tunnel has been started, and theoretical investigations are under way considering the problem of non-steady flow in a tube with heat addition. Experimental and theoretical investigations are under way on burning velocities in Bunsen-type burners. Further work has progressed on addition agents as igniters for hydrocarbon vapors. Work has been undertaken on the development of new instrumentation for flame measurement.

DISTRIBUTION: Copies of this report obtainable from CADO

DIVISION: Power Plants, Jet and Turbine (5)  
SECTION: Combustion Chambers (12)

SUBJECT HEADINGS: Combustion chambers (23683);  
Combustion - Rate of flame propagation (23650);  
Wind tunnels, Supersonic (99125); Flow through tubes  
(41250)

ATI SHEET NO.:

Central Air Documents Office  
Wright-Patterson Air Force Base, Dayton, Ohio

AIR TECHNICAL INDEX

**TITLE:** Project Squid - Quarterly Progress Report (1 July 1947)

ATI- 33404

**AUTHOR(S):** (Not known) (Cornell Aero Lab., Princeton University)  
**ORIGINATING AGENCY:** New York Univ., Polytechnic Inst. of Brooklyn, Purdue Univ.,  
**PUBLISHED BY:** Bureau of Aeronautics, Washington, D. C.

**DIVISION**  
(Nooe)

**ORIG. AGENCY NO.**  
(None)

**PUBLISHING AGENCY NO.**  
(Nooe)

**DATE**  
July '47

**DOC. CLASS.**  
Unclass.

**COUNTRY**  
U.S.

**LANGUAGE**  
Eng.

**PAGES**  
59

**ILLUSTRATIONS**  
photos, diagrs, graphs

**ABSTRACT:**

A quarterly progress report is given on the technical progress attained by Project Squid. Work on flame velocity and combustion has continued mainly with an accumulation of experimental data and theoretical application of these data. An analytical treatment of unsteady flow for compressible fluids is in progress, based upon successive approximations alternating between flow around infinite cylinders and infinite plane. An instrumentation program has been started in view of the expansion of experimental research now contemplated. The simplified gas-dynamical analysis of the pulse jet is in progress of solution, and it will provide a basis for the study of the actual aero-thermodynamical process. Studies of fatigue specimens are being continued, and active work is now under way on temperature distribution studies.

**DISTRIBUTION:** Copies of this report obtainable from Air Documents Division; Attn: MCIDXD

**DIVISION:** Guided Missiles (1)  
**SECTION:** Design and Description (12)

**SUBJECT HEADINGS:** Missiles, Guided - Development (62920);  
Flames, Combustion (37382); Project squid (75406)

ATI SHEET NO.:R-1-12-31

Air Documents Division, Intelligence Department  
Air Materiel Command

AIR TECHNICAL INDEX

Wright-Patterson Air Force Base  
Dayton, Ohio