

UNCLASSIFIED

AD NUMBER
AD493465
NEW LIMITATION CHANGE
TO Approved for public release, distribution unlimited
FROM Distribution authorized to U.S. Gov't. agencies and their contractors; Administrative/Operational use; 31 Aug 1947. Other requests shall be referred to Signal Corps Engineering Labs, Fort Monmouth NJ.
AUTHORITY
USAEC ltr, 27 Jul 1971

THIS PAGE IS UNCLASSIFIED

DDC FILE COPY,

AD 493465

**NOTICE**

This document is the property of the United States Government. It is furnished on a loan basis and shall be returned as specified, or upon recall by ASTIA to the following address: ASTIA Reference Center, Technical Information Division, Library of Congress, Washington 25, D.C.

**RETURN TO:**  
**ASTIA REFERENCE CENTER**  
**LIBRARY OF CONGRESS**  
**WASHINGTON 25, D.C.**

UNANNOUNCED

1

Progress Report  
Report No. 1

Project No. 1992

450025  
C942

THE FRANKLIN INSTITUTE  
LABORATORIES FOR RESEARCH AND DEVELOPMENT  
PHILADELPHIA 3, PENNSYLVANIA

Chemical Engineering and Physics Division

FILE COPY  
NAVY RESEARCH SERVICE  
SCIENCE DIVISION  
LIBRARY OF THE SERVICE  
TO BE RETURNED

493465

9 Progress Report NO. 1, 10 May - 31 Aug 47

6 R. P. Coleman  
Activities in Connection with Basic and Technical  
Work Pertaining to the Development of Thermocouples  
for Use in Thermoelectric Generators

15 Prepared under Contract No. W-36-039-sc-33654  
for  
Signal Corps Engineering Laboratories  
Squier Laboratory  
Fort Monmouth, N. J.

11 31 Aug 47

Since this investigation is still in progress, the  
conclusions expressed in this report are tentative.

12 22 p.

FILE COPY  
Technical Information  
Division  
NO BE RETURNED

SEP 19 1967

Approved by:

Nicol H. Smith

Nicol H. Smith  
Division Director

Approved by:

C. H. Greenall

C. H. Greenall  
Executive Director

Copy No. 42

mk

( 200 900 ) De

DISTRIBUTION LIST

Copy  
Number

1 - 50    Transportation Officer  
          Signal Corps Engineering Laboratories  
          Evans Signal Laboratory  
          Building 42  
          Balmar, New Jersey

For: Signal Property Officer SCKL  
Marked File No. 5182-PH 4791 (4128)

TABLE OF CONTENTS

	<u>Page</u>
1. FOREWORD . . . . .	1
2. PURPOSE . . . . .	1
3. SUMMARY . . . . .	1
4. DISCUSSION . . . . .	2
5. EXPERIMENTAL WORK . . . . .	17
6. PROPOSED EXPERIMENTAL PROCEDURES . . . . .	19
APPENDIX A . . . . .	21

### 1. FOREWORD

A program of theoretical and experimental research is being conducted with the purpose of improving the understanding of thermoelectric properties of materials and of developing a thermocouple of improved efficiency for use in thermoelectric generators.

### 2. PURPOSE

The purpose of this report is to present the results of studies carried on during the period May 10 to August 31, 1947.

### 3. SUMMARY

In this first progress report the general program and the immediate program is outlined.

A general analysis is made of factors affecting the efficiency of a thermoelectric generator. This analysis brings out the dominant importance of finding materials having the highest possible value of the parameter equal to the thermoelectric power squared divided by the ratio of thermal conductivity to electrical conductivity. An approach to the problem of relating this parameter to atomic theory is indicated.

Two lines of experimental work are reported. In one, the efficiency analysis is checked by heating a wire thermocouple electrically and measuring the electromotive force obtained. In the other experiment, simultaneous measurements of thermal emf, thermal and electrical conductivity of silicon are made.

#### 4. DISCUSSION

##### 4.1 General Program

It is planned to attack this problem by concurrent theoretical and experimental procedures. The broad program of research is to include:

- a. Patent and literature search to analyze previous work.
- b. Theoretical study of factors determining efficiency of thermocouples.
- c. Theoretical study of thermoelectric effects based on new approaches to the study of metals and alloys to determine or predict which materials will be the most efficient.
- d. Construction of experimental thermocouples based on theoretical studies.
- e. Experimental tests on thermocouples suggested by theoretical studies to determine specific resistance, thermal conductivity and efficiency.
- f. Study of relationship of crystal size, orientation, etc. to thermoelectric effect.

##### 4.2 Immediate Program

The immediate program includes:

- a. Study of recent literature.

- b. Analysis of efficiency of a thermoelectric generator in terms of the measurable properties of materials and general physical laws.
- c. Derivation of analytical expression for maximum efficiency consistent with thermodynamics, etc.
- d. Study of atomic theory expressions to find possible theoretical limits to efficiency.
- e. Study of theoretical results and published data in order to choose classes of materials that look most promising.
- f. Building of an "efficiency meter" to test the theoretical results on conventional thermocouple materials.
- g. Building of equipment suitable for measurement of thermoelectric power, electrical and thermal conductivity, all on the same sample of material.
- h. Starting tests on silicon as a representative of a material with a reported high thermoelectric power.

4.3

Study of the Literature

A complete list of references and abstracts will be included in the next quarterly report.



#### 4.4 General Analysis of Factors Affecting the Efficiency of a Thermoelectric Generator.

##### 4.4.1 Thermodynamic Considerations

A thermoelectric generator may be thought of as a heat engine in which the working substance is the electron gas whose flow constitutes the electric current. From the most elementary consideration of a thermocouple circuit containing a hot junction at temperature  $T_1$ , and a cold junction at temperature  $T_0$ , a theoretical upper bound can be placed upon the efficiency. For it is known that no heat engine operating between temperatures  $T_1$  and  $T_0$  can have an efficiency exceeding the value

$$\eta_z = \frac{T_1 - T_0}{T_1}$$

Furthermore, by the Thomson effect, some heat will be given out at intermediate temperatures depending upon the current and the temperature gradient. Thus, thermodynamic reasoning alone, by considering only reversible processes fixes an upper bound to the efficiency at somewhat less than

$$\eta_z = \frac{T_1 - T_0}{T_1}$$

depending upon the Thomson coefficient of the thermocouple materials. These considerations indicate the desirability of a large operating temperature ratio,  $T_1/T_0$ .

Thermodynamic considerations likewise imply a set of equations involving the thermal emf, the Peltier coefficient, and the Thomson coefficient.

These equations are known as Kelvin's relations and may be written

$$\frac{dE}{dT} = \frac{\pi}{T}$$

$$\frac{d^2E}{dT^2} = \frac{\mu_1 - \mu_2}{T}$$

All three of the quantities  $\mu$ ,  $\pi$ ,  $E$  are thus determined when one of them is given as a function of temperature.

#### 4.4.2 Analysis of relations between useful power, losses and efficiency of a thermoelectric Generator.

The complete problem of evaluation of efficiency of a thermoelectric generator involves a complicated problem in heat transfer. For the purpose of the present study, however, a preliminary evaluation of efficiency has been made by making certain simplifying assumptions that facilitate the calculations without too greatly impairing their validity.

Studies of efficiency of groups of thermoelectric elements connected in series and parallel and with the resulting output leads connected to a load resistance indicate that the ratio of the total battery resistance to the load resistance is the important parameter influencing the method of connection. It follows that fundamental studies involving a single thermoelement and a suitable load will be sufficient to give the essential information that can be applied also to groups of elements in series and parallel.

The thermoelectric circuit analyzed is shown schematically in Figure F4-1. The circuit is assumed to consist of conductors of two different materials, A and B, joined at two junctions and containing in the circuit also a resistance,  $R_L$  representing the useful load. A certain length of the circuit including one junction is assumed to be in a furnace that maintains its temperature at a uniform value  $T_1$ . Another section of the circuit including the other junction and the load are assumed to be maintained at a uniform cold temperature  $T_0$ . The intervening lengths of conductor are assumed to be surrounded by perfect thermal insulation. This analysis omits the losses in transfer of the heat from the fuel to the hot junction, and the surface heat losses

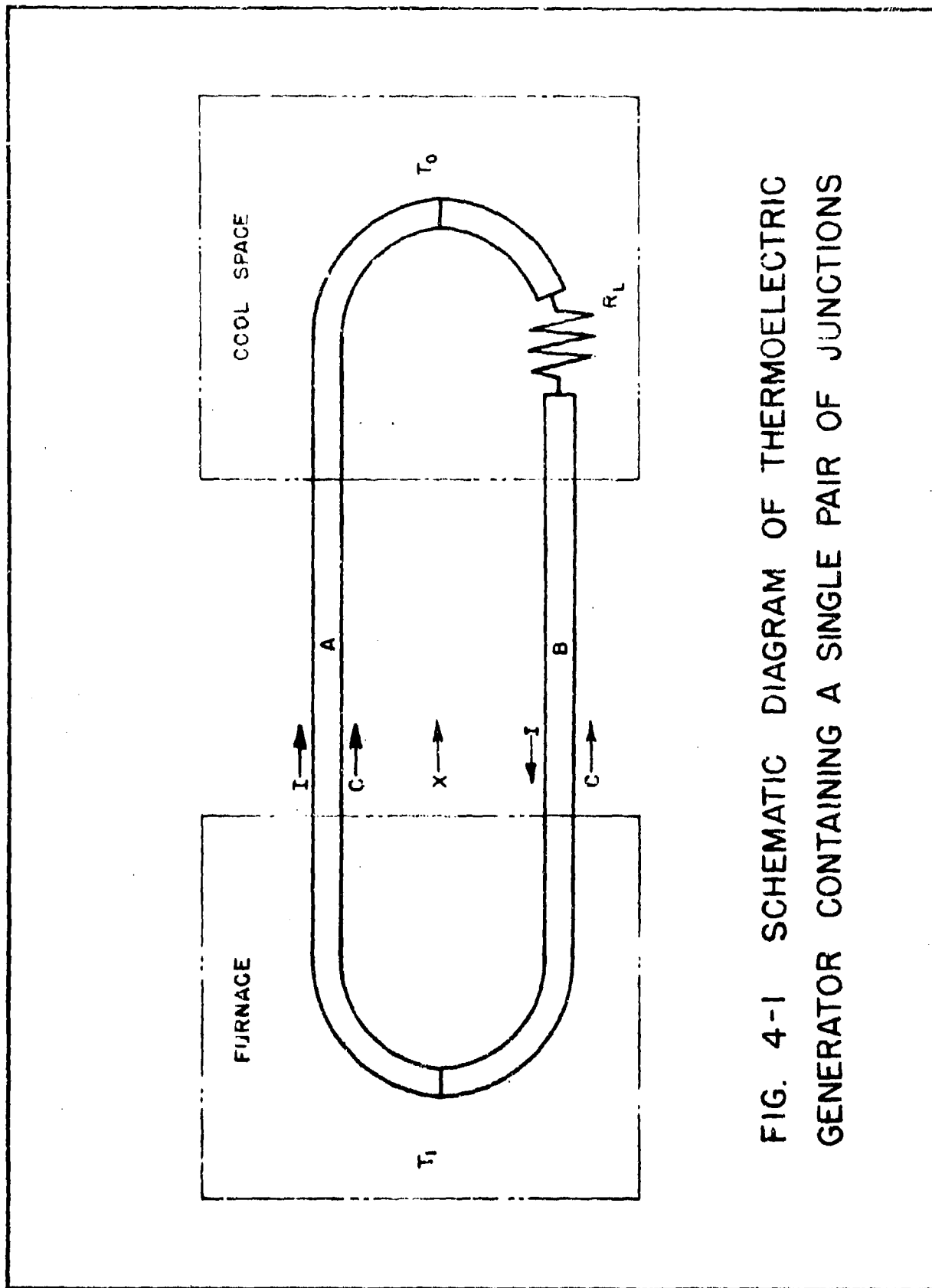

FIG. 4-1 SCHEMATIC DIAGRAM OF THERMOELECTRIC GENERATOR CONTAINING A SINGLE PAIR OF JUNCTIONS

from the part of the leads that are above the cold junction temperature.

An alternative circuit might have been considered in which the temperature distribution in the leads was specified rather than the condition of no surface heat loss. This case is perhaps easier to treat theoretically, but it seems more artificial than the case here treated.

The effects considered include:

- a. Heat required to maintain temperature of conductor at  $T_1$ , inside of furnace. This quantity is the Peltier heat minus the Joule heat inside the furnace plus the heat conduction through the leads.
- b. The heat conduction in the leads, which depends upon the thermal conductivity, the Joule heat, and the Thomson heat in the leads.
- c. The emf which depends upon the materials and the temperatures  $T_1$  and  $T_0$ .

The following equations are readily derived:

Heat added per unit length in the leads is zero.

$$-\frac{d}{dx} \left( \kappa a \frac{dT}{dx} \right) - \frac{I^2}{\sigma a} + \mu I \frac{dT}{dx} = 0$$

Heat added at hot junction is

$$\pi I$$

Heat added to conductor inside of furnace is

$$\pi I - \int_{\text{FURNACE}} \frac{I^2}{\sigma a} dx - \left( \kappa a \frac{dT}{dx} \right)_A - \left( \kappa a \frac{dT}{dx} \right)_B$$

The current is

$$I = \frac{E}{R_L + R_P + R_A + R_B + R_C}$$

The efficiency is

$$\eta = \frac{I^2 R_L}{\pi I - \int_{\text{FURNACE}} \frac{I^2}{\sigma a} dx - \left( \kappa a \frac{dT}{dx} \right)_A - \left( \kappa a \frac{dT}{dx} \right)_B}$$

The evaluation of the heat conduction losses requires a knowledge of the temperature gradient at the furnace wall. This temperature gradient is found by solving the differential equation

$$\frac{d}{dx} \left( \kappa a \frac{dT}{dx} \right) - \mu I \frac{dT}{dx} = - \frac{I^2}{\sigma a}$$

with the boundary conditions

$$T = T_1 \quad \text{AT} \quad x = 0$$

$$T = T_0 \quad \text{AT} \quad x = l$$

With these equations it is possible, in principle, to compute the current, power, and efficiency of a generator when the dimensions and physical parameters are given. However, the variation of  $\kappa$ ,  $\mu$ , and  $\sigma$  with temperature may make the heat conduction equation so difficult to solve that it is desirable to make further simplifying assumptions, in order to arrive at the most useful theoretical results.

Several special cases of the above general method of analysis have been considered. Some of these will be outlined. The general scheme in the solution is to make a sufficient number of simplifying assumptions so that an analytical expression for the maximum efficiency can be found.

It is fairly obvious, in the first place, that any extra length of leads in either the  $T_1$  or  $T_0$  constant temperature regions will decrease the

available useful voltage and the efficiency. In the following, the resistances  $R_F$  and  $R_C$  are consequently assumed to be zero.

Case A. Neglect effect of current upon heat flow in the leads. Assume proportionality of thermal and electrical conductivity in accordance with Wiedemann-Frans law. Neglect  $R_F$  and  $R_C$ . Leads A and B are assumed to have equal resistance.

The differential equation for heat flow becomes

$$\frac{d}{dx} \left( \kappa a \frac{dT}{dx} \right) = 0$$

Hence

$$-\kappa a \frac{dT}{dx} = C, \text{ constant thermal current.}$$

By Wiedemann-Frans law, put

$$\kappa = \sigma LT$$

Then

$$C = -\sigma a LT \frac{dT}{dx}$$

The resistance of lead A is

$$\begin{aligned} R_A &= \int_0^L \frac{dx}{\sigma a} = - \int_0^L \frac{LT}{C} \frac{dT}{dx} dx \\ &= \int_{T_0}^{T_1} \frac{LT}{C} dT = \frac{L}{2C} (T_1^2 - T_0^2) \end{aligned}$$

Or

$$C = \frac{L}{2R_A} (T_1^2 - T_0^2)$$

The efficiency then becomes.

$$\eta = \frac{I^2 R_L}{\pi I + \left(\frac{1}{R_A} + \frac{1}{R_B}\right) \frac{L}{2} (T_1^2 - T_0^2)}$$

Putting for the total battery resistance

$$S = R_A + R_B$$

and assuming

$$R_A = R_B$$

and using the relation

$$I = \frac{E}{R_L + S}$$

we obtain

$$\frac{1}{\eta} = \frac{\pi}{E} \left(1 + \frac{S}{R_L}\right) + \frac{G}{E^2} \frac{\left(1 + \frac{S}{R_L}\right)^2}{\frac{S}{R_L}}$$

where

$$G = \frac{L}{2} (T_1^2 - T_0^2)$$

The maximum efficiency, corresponding to the minimum value of  $1/\eta$ , can now be found by equating to zero the derivative of  $1/\eta$  with respect to  $S/R_L$ .

$$\frac{d}{d\left(\frac{S}{R_L}\right)} \left(\frac{1}{\eta}\right) = \frac{\pi}{E} + \frac{G}{E^2} \left(1 - \frac{2}{S/R_L}\right) = 0$$

then

$$\frac{S}{R_L} = \frac{1}{\left(1 + \frac{\pi}{E} \frac{E^2}{G}\right)^{1/2}}$$

Then the maximum efficiency is

$$\eta_{\max} = \frac{E}{\pi} \frac{\lambda - 1}{\lambda + 1}$$

where

$$k = \frac{R_L}{3} = \left(1 + \frac{\pi}{E} \frac{E^2}{G}\right)^{1/2}$$

It should be recalled that

$$T = T \frac{dE}{dT}$$

Case B. Consider Joule heat in leads, but neglect Thomson heat. Assume  $\kappa$  and  $\sigma$  are independent of temperature and put  $\kappa = \sigma L T$  where  $T$  represents an average temperature.

The differential equation for heat flow becomes

$$\frac{d}{dx} \left( \kappa \frac{dT}{dx} \right) = - \frac{j^2}{\sigma}$$

with boundary conditions

$$T = T_1 \quad \text{AT} \quad x = 0$$

$$T = T_0 \quad \text{AT} \quad x = l$$

The solution satisfying these boundary conditions is

$$T = T_1 + \left( \frac{T_0 - T_1}{l} + \frac{j^2 l}{2 \kappa \sigma} \right) x - \frac{j^2}{2 \kappa \sigma} x^2$$

The heat conduction loss in one lead is

$$\begin{aligned} - \left( \kappa a \frac{dT}{dx} \right)_{x=0} &= \kappa a \left( \frac{T_1 - T_0}{l} - \frac{j^2 l}{2 \kappa \sigma} \right) \\ &= \kappa a \left( \frac{T_1 - T_0}{l} \right) \left[ 1 - \frac{I^2 R_A^2}{2 L T (T_1 - T_0)} \right] \\ &= \kappa a \left( \frac{T_1 - T_0}{l} \right) \left[ 1 - \frac{E^2}{2 L T (T_1 - T_0)} \frac{R_A^2}{(R_A + R_0 + R_L)^2} \right] \end{aligned}$$



With the substitutions

$$\kappa = \sigma L T = \sigma L \frac{T_1 + T_2}{2}$$

$$\frac{\sigma a}{2} = \frac{1}{R_A}$$

The heat conduction loss in one lead becomes

$$C_A = -(\kappa a \frac{dT}{dx})_{x=0} = \frac{1}{R_A} \frac{L}{2} (T_1^2 - T_2^2) \left[ 1 - \frac{E^2}{L(T_1^2 T_2^2)} \frac{R_A^2}{(R_A + R_0 + R_L)^2} \right]$$

With the same substitutions as in Case A, we obtain

$$\begin{aligned} \frac{1}{\eta} &= \frac{\pi}{E} \left( 1 + \frac{S}{R_L} \right) + \frac{G}{E^2} \frac{\left( 1 + \frac{S}{R_L} \right)^2}{\frac{S}{R_L}} \left[ 1 - \frac{E^2}{2G} \frac{S^2}{(S + R_L)^2} \right] \\ &= \frac{\pi}{E} \left( 1 + \frac{S}{R_L} \right) + \frac{G}{E^2} \frac{\left( 1 + \frac{S}{R_L} \right)^2}{\frac{S}{R_L}} - \frac{1}{2} \frac{S}{R_L} \end{aligned}$$

The maximum efficiency is determined from

$$\frac{d \left( \frac{1}{\eta} \right)}{d \left( \frac{S}{R_L} \right)} = \frac{\pi}{E} - \frac{G}{E^2} \left( \frac{R_L^2}{S^2} - 1 \right) - \frac{1}{2} = 0$$

$$\frac{S}{R_L} = \frac{1}{\left[ 1 + \frac{E^2}{G} \left( \frac{\pi}{E} - \frac{1}{2} \right) \right]^{1/2}}$$

Then

$$\eta_{\max} = \frac{\lambda - 1}{\frac{\pi}{E} (\lambda + 1) - 1}$$

where

$$\lambda = \frac{R_L}{S} = \left[ 1 + \frac{E^2}{G} \left( \frac{\pi}{E} - \frac{1}{2} \right) \right]^{1/2}$$

Case C. Consider both Joule heat and Thomson heat in leads.

Assume  $\kappa$ ,  $\sigma$ , and  $\mu$  are independent of  $T$ .

The differential equation for heat flow is

$$\frac{d}{dt} \left( \kappa a \frac{dT}{dx} \right) - \mu I \frac{dT}{dx} = - \frac{I^2}{\sigma a}$$

with the boundary conditions

$$T = T_1 \quad \text{at } x = 0$$

$$T = T_2 \quad \text{at } x = l$$

The solution is

$$T = \left( T_0 - T_1 + \frac{Ib}{\mu\sigma a} \right) \frac{\left( \frac{\mu I x}{ka} - 1 \right)}{\left( e^{\frac{\mu I b}{ka}} - 1 \right)} - \frac{I x}{\mu\sigma a} + T_1$$

And the temperature gradient at  $x = 0$  is

$$\left( \frac{dT}{dx} \right)_{x=0} = \frac{T_0 - T_1 + \frac{Ib}{\mu\sigma a}}{\left( e^{\frac{\mu I b}{ka}} - 1 \right)} \frac{\mu I}{ka} - \frac{I}{\mu\sigma a}$$

With the substitutions

$$K = \frac{ka}{l}$$

$$R_A = \frac{l}{\sigma a}$$

$$\kappa = \sigma L \left( \frac{T_1 + T_0}{2} \right)$$

The heat conduction loss in lead A, where  $I$  is positive, is

$$C_A = - \left( ka \frac{dT}{dx} \right)_{x=0} = \frac{1}{R_A} \frac{l}{2} (T_1^2 - T_0^2) \left[ \frac{1 - \frac{I R_A}{\mu(T_1 - T_0)}}{e^{\frac{\mu I}{K}} - 1} \frac{\mu I}{K} + \frac{I R_A}{\mu(T_1 - T_0)} \right]$$

In the expression referring to lead B, it is necessary to write

$-I$  in place of  $I$ .

The efficiency can now be computed for any particular set of values of the parameters. The analytical expression for maximum efficiency is more complicated than in case A or B and has not been explicitly obtained.

#### 4.4.3 Use of Material having High Resistivity

Examination of published data on resistivity and thermoelectric power indicates a degree of correlation between high resistivity and high thermoelectric power. The material selected as most efficient for a thermoelectric generator is likely, therefore, to have a high resistivity. A brief theoretical study has been made of factors determining the upper limit of high resistance material which it is desirable to use.

In the analysis of efficiency it is the total resistance rather than resistivity that appears, so that high resistivity material can be used efficiently by having a sufficiently small path length between hot junction and cold junction.

Thin films (large section, short length) of high resistivity material appear to be equivalent to greater path lengths of better conducting material. The practical limit to the use of thin films will depend upon matters of technique which cannot readily be specified in a simple theoretical analysis. If a series of materials of increasing resistance and increasing thermoelectric power followed the theoretical Wiedemann-Franz law, then this simple analysis would indicate that the material of highest resistivity was best.

The Joule heating effect can hardly be the limiting factor by causing damage to anything if the temperature does not exceed the hot junction temperature. The condition that the highest temperature due to Joule heating just equals the hot junction temperature can be found from Case B above and is

$$1 - \frac{E^2}{2G} \frac{S^2}{(S + R_L)^2} = 0$$

This condition implies an extremely high value of  $E^2/G$  and an extremely high efficiency. The heating effect is therefore very unlikely to be the limiting factor in the design of a thermoelectric generator.

#### 4.5

#### Indications from Atomic Theory

The analysis of efficiency of a thermoelectric generator has shown that the main problem is to find the pair of materials having the largest value of the quantity  $E^2/G$  for a convenient temperature range. The problem for theoretical study is therefore to obtain information about the attainment

of high values of  $E^2/G$ .

It is almost equivalent and more convenient to consider the quantity  $Q^2/L$  instead of  $E^2/G$  in considering materials.

The modern theory of solids, based on quantum mechanics indicates, in principle, the way to compute the thermoelectric power etc. of specific substances, but the structure of solids is generally too complicated for these computations to be carried out for specific materials entirely from first principles. Instead, a combination of theoretical and empirical study seems to offer the best chance of success in this problem.

One type of attack on this problem is to look for theoretical indications of an upper limit to possible values of  $E^2/G$  or  $Q^2/L$ . Such a study is likely also to lead to suggestions as to specific materials or to a correlation of these parameters with other physical properties of solids.

Not enough progress along this line has yet been made to make it possible to speak of results. Only some indications of lines of thought can be given. One line of thought follows from the treatment of thermoelectricity given in the book, "Properties of Metals and Alloys", by Mott and Jones.

The electric current density,  $I/a$  and the heat current density,  $C/a$ , in a wire are given on page 306 as linear functions of the electric field,  $F$ , and the temperature gradient of  $dT/dx$ .

$$\frac{I}{a} = a_{11} F + a_{12} \frac{dT}{dx}$$

$$\frac{C}{a} = a_{21} F + a_{22} \frac{dT}{dx}$$

where

$$a_{11} = e^2 K_0$$

$$a_{12} = e K_0 \left( \frac{E}{T} - \frac{\partial E}{\partial T} \right) - \frac{e K_1}{T}$$

$$a_{21} = e K_1$$

$$a_{22} = K_1 \left( \frac{E}{T} - \frac{\partial E}{\partial T} \right) - \frac{K_2}{T}$$

$K_0, K_1, K_2$  are defined by

$$K_n = -\frac{2}{\pi^2} \frac{1}{8\pi^3} \int \epsilon^n \left( \frac{\partial \epsilon}{\partial k_x} \right)^2 \frac{\partial f_0}{\partial \epsilon} \tau(\underline{k}) d\underline{k}$$

where  $\epsilon$  refers to energy of an electron in the metal

$f_0$  is the Fermi distribution function

$k_x, \underline{k}$  are wave number and wave vector

$\tau(\underline{k})$  is the relaxation time of the change in the Fermi distribution due to collisions

$\xi$  is the Fermi energy

In this notation the expression for the electrical conductivity

is

$$\sigma = \sigma_{11} = e^2 K_0$$

The thermal conductivity with zero electric current is

$$\kappa = \frac{\sigma_{12} \sigma_{21}}{\sigma_{11}} - \sigma_{22} \\ = -\frac{\left( \frac{K_1^2}{K_0} - K_2 \right)}{T}$$

The Thomson coefficient is

$$\mu = -\frac{T}{e} \frac{\partial}{\partial T} \left\{ \frac{1}{T} \left( \frac{K_1}{K_0} - \xi \right) \right\}$$

so that the thermoelectric power defined for a single substance as

$$Q = \int_0^T \frac{\mu}{T} dT$$

THE FRANKLIN INSTITUTE Laboratories for Research and Development

is given by

$$Q = \frac{1}{\epsilon} \left\{ \frac{1}{T} \left( \frac{K_1}{K_0} - \mathcal{F} \right) \right\}$$

Values of  $\sigma$ ,  $\kappa$ , and  $Q$  can now be computed for any special set of assumptions about the quantities determining  $K_n$ . In Mott and Jones, the integral  $K_n$  is evaluated as follows: let us denote by  $\phi(\epsilon')$  the integral.

$$\phi(\epsilon') = \frac{1}{\hbar^2} \frac{1}{8\pi^3} \iint \left( \frac{\partial \epsilon}{\partial k_x} \right)^2 \tau \left( \frac{1}{2} \right) \frac{dS}{|grad \epsilon|}$$

the integration being over the surface  $\epsilon(k) = \epsilon'$  in  $k$ -space. Then

$$-K_n = \int_0^\infty \phi(\epsilon) \epsilon^n \frac{\partial f_0}{\partial \epsilon} d\epsilon$$

Since  $\partial f_0 / \partial \epsilon$  vanishes except in a small range about the point  $\epsilon = \mathcal{F}$ , the above integral may be expanded in ascending powers of  $T$ , we obtain

$$K_n = \mathcal{F}^n \phi(\mathcal{F}) + \frac{\pi^2}{6} (\mathcal{L}T)^2 \frac{d^2}{d\mathcal{F}^2} \left\{ \mathcal{F}^n \phi(\mathcal{F}) \right\} \dots$$

The first approximation leads to

$$\kappa = \frac{\pi^2}{3} \mathcal{L}^2 T \phi(\mathcal{F})$$

$$\sigma = \mathcal{L}^2 \phi(\mathcal{F})$$

$$Q = \frac{\pi^2}{3} \frac{\mathcal{L}^2 T}{\mathcal{L} \mathcal{F}} \kappa$$

where  $x$  comes from the assumption that

$$\sigma(\epsilon) = \text{const. } \epsilon^x$$

This result appears at first to indicate that  $Q$  can be increased without limit by decreasing  $\mathcal{F}$ , but this conclusion is limited by the neglect of higher terms in the Taylor's expansion for  $K_n$ .

This expansion has been worked out beyond what is given in the book.

The next higher approximation yields.

$$Q = \frac{\mathcal{L}}{\epsilon} \frac{\frac{\pi^2}{3} \frac{\mathcal{L}T}{\mathcal{F}} \kappa}{1 + \frac{\pi^2}{6} \left( \frac{\mathcal{L}T}{\mathcal{F}} \right)^2 x(x-1)}$$

$$\frac{K_1}{\sigma T} = \mathcal{L} = \left( \frac{\pi^2}{3} \frac{\mathcal{L}^2}{\mathcal{L} \mathcal{F}} \right) \frac{1 - \frac{\pi^2}{6} \left( \frac{\mathcal{L}T}{\mathcal{F}} \right)^2 x^2}{1 + \frac{\pi^2}{6} \left( \frac{\mathcal{L}T}{\mathcal{F}} \right)^2 x(x-1)}$$

Although this expression for  $Q$  indicates the existence of a maximum value, it is felt that more study is needed before such a result can be interpreted with confidence.

#### 5. EXPERIMENTAL WORK

In order to check some of our theoretical calculations it was decided to set up an "efficiency meter" for measuring the efficiency of conventional thermocouple materials. A set up was desired which would measure the efficiency of the thermocouple itself without having to consider the furnace losses. In a thermocouple which is heated by an external heater a large amount of heat is lost which never gets to the thermocouple. For this reason it was decided to heat the thermocouple junction by the Joule heat produced when a current was passed through it. A vibrator was used which alternately connected the thermocouple to the battery supplying the heating current and to an external measuring circuit for determining the output power. A schematic diagram of this circuit is shown in Figure 5-1.

A chromel-P-alumel thermocouple was used with this circuit. Output power was computed from the emf measured on the potentiometer with an assumed external load whose resistance was equal to that of the thermocouple. Experiments were done with thermocouple leads of various lengths. The best efficiencies were obtained using very short thermocouples. The thermocouples were mounted in a vacuum to eliminate convection current and conduction losses due to surrounding air.

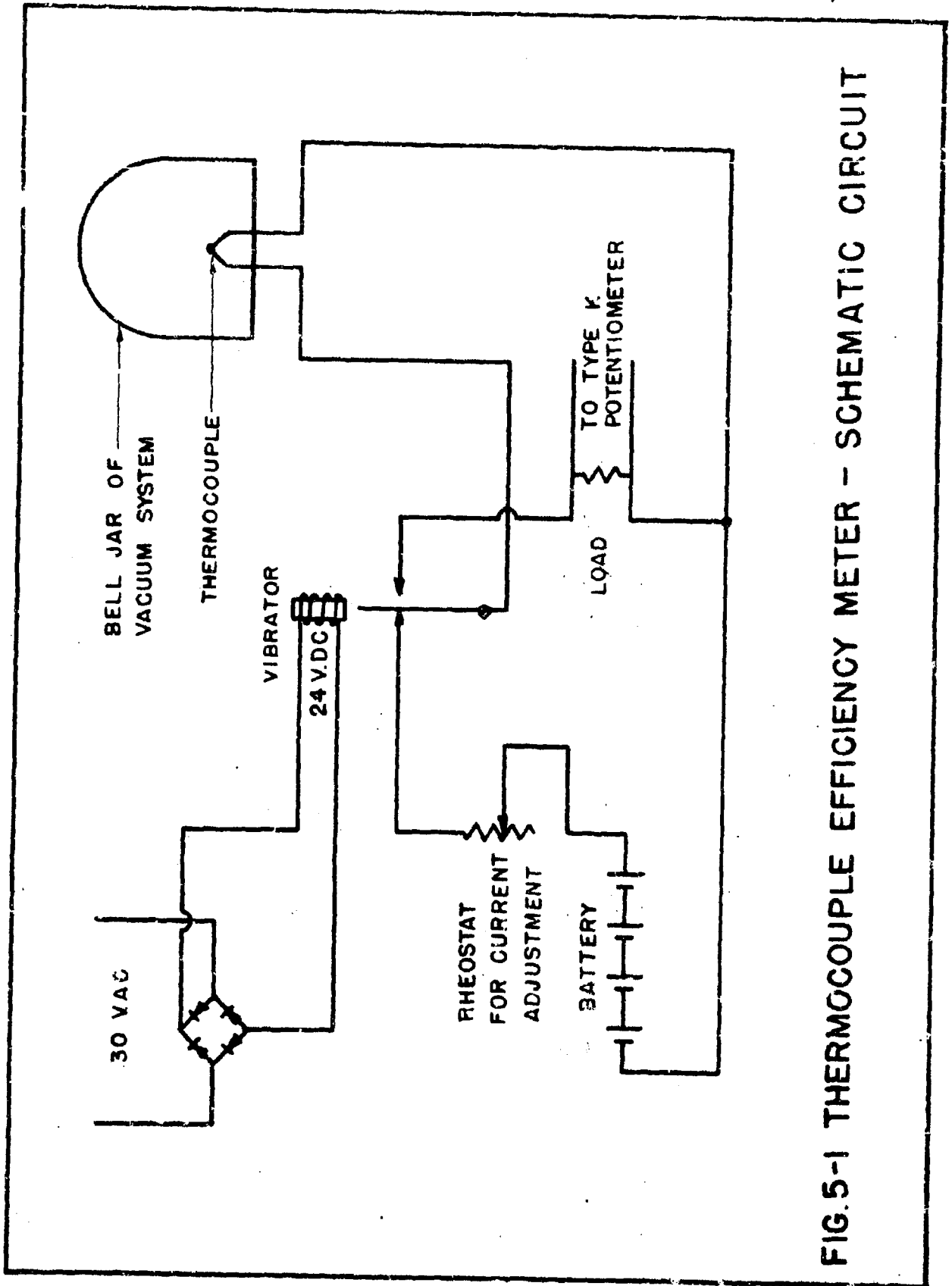

FIG. 5-1 THERMOCOUPLE EFFICIENCY METER - SCHEMATIC CIRCUIT

12

0



Our work indicates an efficiency of .42% for the shortest length thermocouple used. The leads to this thermocouple were 0.3 cm long. Below is shown a computation for a chromel-P-alumel thermocouple using the normal value of the Wiedemann-Franz ratio for metals and emf's and temperatures taken from standard thermocouple tables.

$$\frac{1}{\eta} = \frac{\pi}{E} \left( 1 + \frac{S}{R_L} \right) + \frac{G}{E^2} \frac{\left( 1 + \frac{S}{R_L} \right)^2}{\frac{S}{R_L}}$$

S is assumed equal to  $R_L$

$$G = 2L(T_1^2 - T_0^2)$$

$$\frac{\pi}{E} = \frac{T_1}{T_1 - T_0}$$

$$\frac{1}{\eta} = \left( \frac{1093}{795} \right) (2) + \frac{(2)(2.45 \times 10^{-8})(4)(1093^2 - 300^2)}{.0331^2}$$

$$= 2.8 + 198 = 200.8$$

$$\eta = 0.005 = .5 \%$$

$$\text{OBSERVED } \eta = 0.42 \%$$

This calculation shows good agreement with the observed data.

A special type of furnace was built which enabled us to measure the thermoelectric power, the thermal conductivity and the electrical conductivity of powdered semi-conductors. This furnace has been used only to measure properties of powdered commercial silicon. A diagram of the furnace is shown in Figure 5-2.

The data indicate that silicon has a very high thermoelectric power in the temperature range in which observations were made. Although

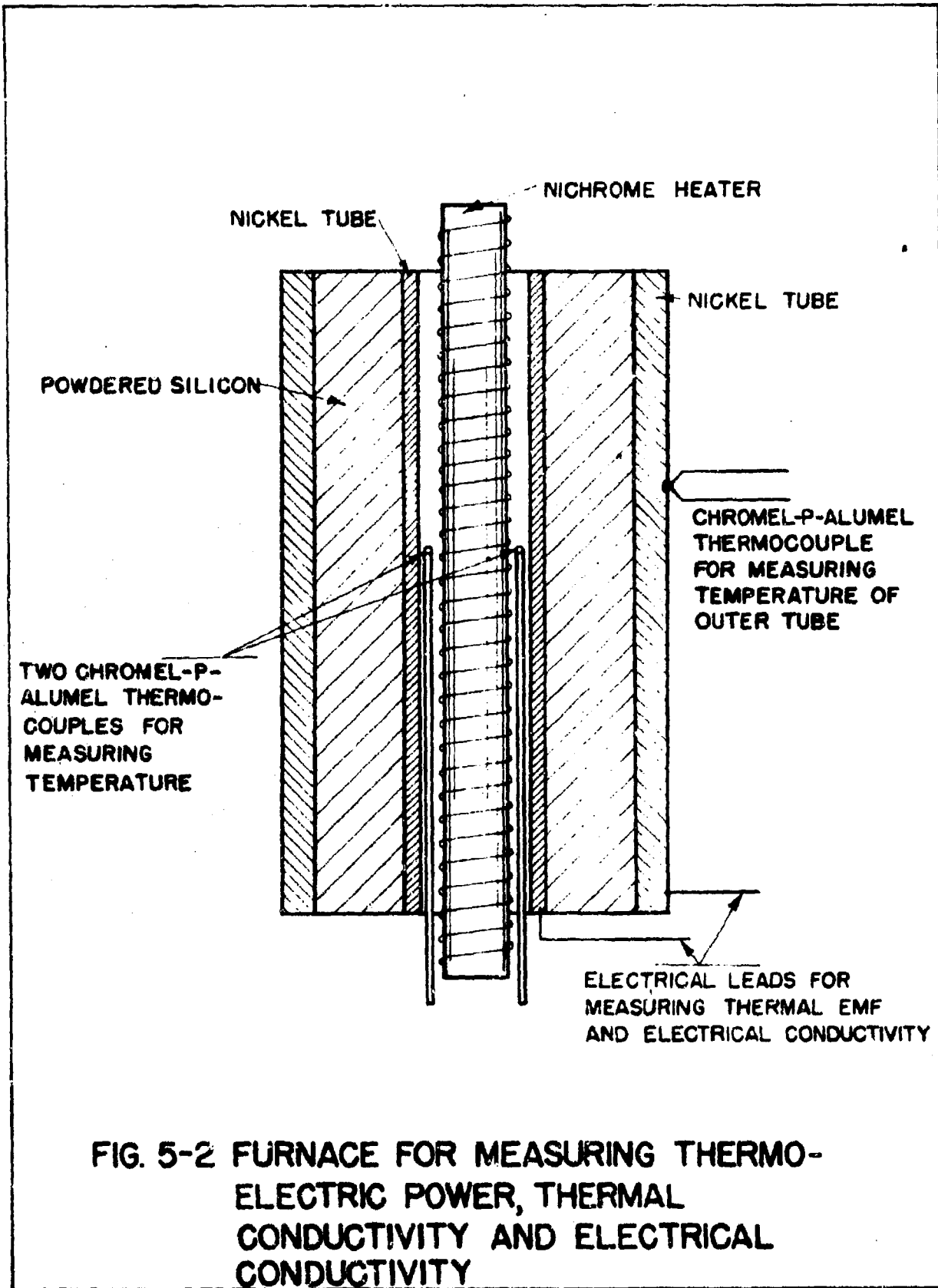

FIG. 5-2 FURNACE FOR MEASURING THERMO-ELECTRIC POWER, THERMAL CONDUCTIVITY AND ELECTRICAL CONDUCTIVITY

some unexplained erratic effects were encountered, an apparent thermal emf of approximately 1.8 volts was observed at a hot junction temperature of 664°C when the temperature of the cold junction was 254°C. This thermal emf decreased rapidly as the temperature was increased reaching zero at a hot junction temperature of 856°C and a cold junction temperature of 317°C. At hot junction temperatures below 600°C the resistance of the silicon became too great to make accurate readings of the thermal emf. More work will be necessary to determine exactly the temperature at which the peak in this curve occurs.

#### 6. PROPOSED EXPERIMENTAL PROCEDURES

Since silicon shows promise of being a good material for use in thermoelectric generators it is proposed to conduct a number of experiments on silicon to determine more exactly what these properties are and how they can be controlled.

The thermoelectric properties of silicon are probably largely due to impurities and it is known that silicon can have a positive or negative sign of the thermoelectromotive force, depending on the impurities present. For these reasons some highly purified silicon has been ordered. We hope with this material to add impurities in controlled experiments to obtain a thermocouple material of high efficiency.

The length of a thermocouple should be short and the cross section should be large in order to be able to obtain larger currents. It is possible that thermocouples formed by evaporating silicon on a metal or by evaporating metal onto silicon which has been melted in a vacuum may have high efficiencies when used in thermoelectric generators.

Considerations will be given to methods of preparing samples such as melting, sintering and evaporating.

More experimental work will be needed to obtain simultaneous data on thermoelectric power and electrical and thermal conductivity on the same sample of material.

R. P. Coleman

*R. P. Coleman*  

---

Research Physicist - Project Head

## APPENDIX A

## List of Symbols

- $a$  = cross section area
- $g_1, g_{12}, g_{21}, g_2$  = quantities defined in section 4.5
- A = referring to material A
- B = referring to material B
- C = thermal current
- E = thermal electromotive force
- $e$  = electronic charge
- F = electric field strength
- G = the quantity  $2L(T_1^2 - T_0^2)$
- $h$  = Planck's constant divided by  $2\pi$
- I = total electric current
- J = electric current density
- K = thermal conductance,  $\kappa a/l$
- $K_n, K_1, K_2$  = integral expressions occurring in atomic theory. Used collectively as  $K_n$
- $k$  = Boltzmann's constant, substitution for  $R_L/5$  in expressions for  $\eta_{max}$
- $k_x$  = wave number along x axis
- $\mathbf{k}$  = wave number vector
- L = Lorentz number
- $l$  = length of thermocouple lead
- Q = thermoelectric power
- $R_L$  = resistance of load
- $R_A, R_B$  = resistance of leads of materials A and B

- $R_f$  = resistance of conductor inside of furnace
- $R_c$  = resistance of conductor in the cool space
- $S$  = total resistance of thermoelectric circuit excluding useful load
- $T$  = temperature, °K
- $\bar{T}$  = average temperature, °K
- $T_h, T_c$  = temperature of hot junction and cold junction
- $x$  = coordinate along thermocouple wire
- $\epsilon$  = energy
- $\xi$  = Fermi energy
- $\eta$  = efficiency
- $\eta_I$  = ideal thermodynamic efficiency
- $\kappa$  = thermal conductivity
- $\mu$  = Thomson coefficient
- $\Pi$  = Peltier coefficient
- $\sigma$  = electrical conductivity