

AN EARTH'S FIELD MAGNETOMETER THAT
UTILIZES THE FREE PRECESSION OF PROTONS

CHARLES H. BOWEN, JR.

AD 485101

Library
U. S. Naval Postgraduate School
Monterey, California

AN EARTH'S FIELD MAGNETOMETER
THAT UTILIZES THE FREE
PRECESSION OF PROTONS

Charles H. BOWEN, Jr.

AN EARTH'S FIELD MAGNETOMETER
THAT UTILIZES THE FREE
PRECESSION OF PROTONS

by

Charles H. Bowen, Jr.
" "
Lieutenant, United States Navy

Submitted in partial fulfillment

of the requirements
for the degree of
MASTER OF SCIENCE
IN
ENGINEERING ELECTRONICS

United States Naval Postgraduate School
Monterey, California

1954

Thesis
B74

This work is accepted as fulfilling
the thesis requirements for the degree of

MASTER OF SCIENCE
IN
ENGINEERING ELECTRONICS

from the
United States Naval Postgraduate School

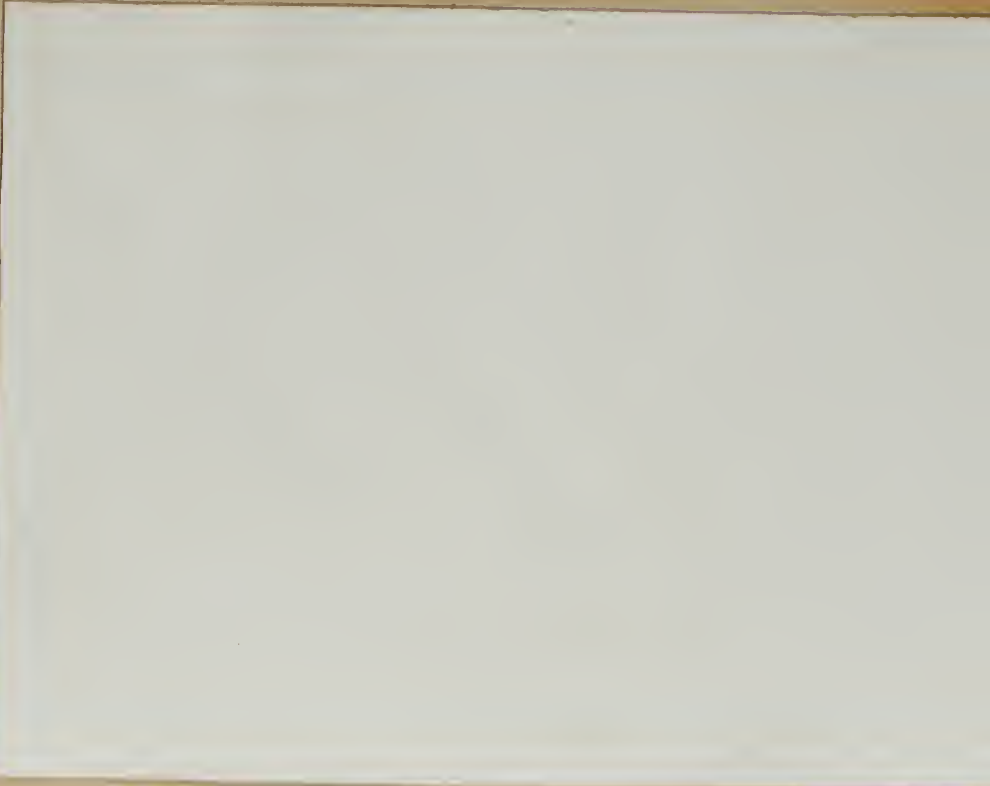

25283

PREFACE

This paper describes the instrumentation of a new type of device for measuring the absolute values of, as well as small changes in, the earth's magnetic field.

The author's work on this device was accomplished at the Varian Associates research Laboratory at Palo Alto, California, during the period January to March, 1954, while a student in the Electronics Engineering curriculum at the U.S. Naval Postgraduate School, Monterey, California.

The idea that the technique described in this paper would be a feasible method for measuring the earth's magnetic field was conceived by Dr. Russell Varian and a basic patent on use of this technique was granted to him in 1948.

The author wishes to express his appreciation to Varian associates, to Messrs. Dolan Mansir and John Drake for their cooperation and especially to Dr. Martin Packard, the Director of Nuclear Spectroscopy at the laboratory, for his help and encouragement.

TABLE OF CONTENTS

	Page
Preface	ii
Table of Contents	iii
List of Illustrations	v
Chapter I Introduction	1
Chapter II Other types of Magnetometers	
1. Dip Needles	2
2. Earth Inductor	2
3. Schmidt-Type Magnetometer	2
4. Magnetic Airborne Detector	
a. Gulf Airborne Detector	3
b. NOL Magnetic Airborne Detector	3
5. Station Magnetometer	3
Chapter III Method of Attack	
1. Theoretical Background	5
2. A New Type Magnetometer	16
Chapter IV Experimental Equipment	
1. Polarizing Coils	26
2. Receiving Coil	29
3. Water Sample	31
4. Preamplifier	31
5. Amplifier, Narrow Band	32
6. Gating and Counting Circuits	37
7. Analoging Circuit	42
Chapter V Experimental Results	44
Chapter VI Conclusions	
1. Possible Errors	46
2. General Comments and Applications	46

TABLE OF CONTENTS

	Page
Appendix I	48
Appendix II	57
Appendix III	58
Appendix IV	59
Appendix V	86
Bibliography	87

LIST OF ILLUSTRATIONS

Figure		Page
1.	Precession of nuclear magnetic moment about the polarizing field	8
2.	Position of polarizing and R.F. coils	8
3.	\vec{H}_0 , \vec{H}_1 and \vec{M} vectors	9
4.	Components of vector \vec{M}	11
5.	Proton resonance for .1 molar solution of <i>Mn SO₄</i> in water	12
6.	30 M.C. R.F. Head	14
7.	Nuclear spectroscopy tape for ethyl alcohol	15
8.	Direction of vector \vec{M} after polarization	17
9.	Orientation of receiving coil	19
10.	Block diagram of earth's magnetic field measuring equipment	19
11.	Input to first stage of preamplifier	21
12.	Exponential rise of sine wave signal impressed on a high Q circuit	22
13.	Waveform produced by signal $Ae^{-\alpha t}$ impressed on a circuit with a Q of 200	23
14.	Timing wheel	27.
15.	Polarizing coil circuit	28
16.	Transient response of polarizing coil	29
17.	Preamplifier	32
18.	Q multiplier circuit	33
19.	Photographs showing result of impressing a sine wave on a high Q circuit	35 36
20.	Narrow band amplifier	36

LIST OF ILLUSTRATIONS

Figure		Page
21.	One stage of binary circuit	38
22.	Binary gating counter	39
23.	Timing wheel	40
24.	Diurnal change in earth's magnetic field	45

CHAPTER I

INTRODUCTION

The measurement of the earth's magnetic field has long been of interest to various magnetic observatories throughout the world, to those interested in magnetic prospecting, and to the military in anti-submarine work. This paper describes the instrumentation of a new type magnetometer that measures the earth's field by measuring the free precession frequency of the protons in water.

Results obtained indicate that with the present equipment configuration the earth's magnetic field can be measured to within $2 \gamma^*$ (out of 50000 γ) on an absolute basis and that changes of $\frac{1}{4} \gamma$ can be detected. This technique probably represents the most accurate method presently available for measuring the absolute value of the earth's magnetic field. Further, changes of much less than $\frac{1}{4} \gamma$ could be detected by this method if it were necessary or desirable simply by increasing the frequency of the crystal controlled source in the counting system.

Possible applications include: use as a station magnetometer for a magnetic observatory, use for magnetic surveying or prospecting, and use in harbor defense and air anti-submarine work.

$$* 1 \gamma = 10^{-5} \text{ gauss}$$

CHAPTER II

OTHER TYPES OF MAGNETOMETERS

1. Dip Needles

This is simply a compass needle free to move in a vertical plane with an adjustable weight attached on one side of the pivot. A balance is achieved between gravitational and magnetic torques. Changes in the vertical component of the earth's magnetic field changes the magnetic moment and results in an unbalance in the forces.

This device measures changes in the earth's magnetic field and will detect anomalies of approximately 300 γ . The earth's magnetic field, as mentioned in the introduction, is about 50000 γ .

2. Earth Inductor

This instrument is frequently used by magnetic observatories for measuring the inclination of the earth's magnetic field. It consists of a high speed rotating coil which generates a voltage for all orientations except those for which its axis is parallel to that of the magnetic field being measured. It can also be used as a crude device for measuring the magnitude of a magnetic field since the voltage generated by the rotating coil is proportional to strength of the magnetic field whose flux is being cut. When used to measure the absolute value of the earth's magnetic field it is accurate to within about 1000 γ .

3. Schmidt-Type Magnetometer

This device is widely used in magnetic prospecting. It is similar to the dip needle in that there are opposing gravitational and magnetic torques. It is much more sensitive than the dip needle, however. It consists of a magnet that is pivoted--but not pivoted at its center of mass. By careful adjustment it can be made to detect changes in the

earth's field of a few gamma—even one gamma under favorable conditions.

4. Magnetic Airborne Detector

a. Gulf Airborne Detector (9)

This device is also known as the flux-gate magnetometer or saturable reactor. It utilizes a ferro magnetic element of high permeability such that the earth's field can very nearly saturate it. If an alternating field, obtained from a coil, is superimposed on the earth's field the core will saturate each cycle. The phase of each cycle at which saturation occurs gives a measure of the earth's field. Small changes of a fraction of 1% can be detected in this way. The instrument does not provide an absolute measure.

b. NOL Magnetic Airborne Detector (6)

The magnetic airborne detector developed by NOL (Naval Ordnance Laboratory) and Bell Laboratories operates on a slightly different principle. Here a single core is driven into saturation about 2000 times a second. A back electromotive force is set up in the magnetizing coil which has even harmonics when there is an external field in the direction of the axis but only odd harmonics when there is no such field. The amplitude of the even harmonic content as recorded on a tape is proportional to the field strength. This instrument measures changes of a fraction of one% but does not measure the absolute value of the earth's field.

5. Station Magnetometer

Even a brief description of a station magnetometer would be too lengthy for a paper of this sort. McComb, (5) in a U.S. Department of Commerce Publication, describes in detail how a magnetic observatory

should be set up and equipped. The Coast and Geodetic Survey maintains two magnetic observatories in this country--one at Tucson, Arizona and the other at Cheltenham, Massachusetts. A station typically has a triple walled building with sawdust between one pair of walls and air between the other pair to reduce temperature and humidity changes in sensitive equipment. Standard magnets are used and complex optical equipment is necessary. This is mentioned to illustrate the difficulty previously encountered in making earth's field measurements. Accuracy of better than 5 % for an absolute earth's field measurement was very difficult to obtain.

CHAPTER III

METHOD OF ATTACK

1. Theoretical Background

An entirely new approach to the magnetometer problem was opened by the field of nuclear induction or nuclear magnetic resonance. Bloch, Packard and Hansen (2) at Stanford and Purcell, Torey and Pound (8) at Harvard pioneered in this work. A brief amount of background material follows. The notation used follows that of Block (2) and Packard (7).

The phenomenon of nuclear induction is possible because of two inherent properties of the nuclei: their angular momentum and magnetic moment. The unit for magnetic moments is the Bohr magneton

$$\mu_B = \frac{e \hbar}{2 m c}$$

where e is the charge on an electron, m represents its mass, c is the velocity of light and \hbar equals 1.05×10^{-27} erg-sec. ($2\pi\hbar$ is Planck's constant). The nuclear magneton is related to the Bohr magneton simply by the ratio of the mass of the proton to that of the electron. For the nuclear magneton

$$\mu_{nm} = \frac{e \hbar}{2 m c} = 5.049 \times 10^{-24} \text{ erg/gauss}$$

However, careful measurements have shown that for the proton, since it is not simply a spinning spherical shell of mass m and charge e , that its magnetic moment is 2.7935 times the theoretical value. The measured ratio of magnetic moment of proton to that of the electron is 1/660.

The second characteristic property is the angular momentum, \vec{a} , and is given in units of \hbar .

The angular momentum and magnetic moments are related by the gyromagnetic ratio gamma, γ . (This γ is unrelated to the unit of magnetic field).

$$\vec{\mu} = \gamma \vec{a}$$

The vectors $\vec{\mu}$ and \vec{a} are either parallel, in which case γ is positive, or anti-parallel and γ is then negative.

We wish to have a relationship between magnetic field strength and frequency. This can be obtained by considering the energy difference E between the Zeeman levels for a material placed in magnetic field of strength H .

$$E = \frac{\mu H}{I} = \omega \hbar$$

and since $\mu = 1.41 \times 10^{-23}$ erg/gauss and $I = 1/2$ for protons, then $\omega = \left(\frac{\mu}{\hbar/2} \right) H$

The quantity in the parentheses in the gyromagnetic ratio and we have ω equals γH . The frequency is termed the Larmor frequency and for protons,

$$\frac{\gamma_P}{2\pi} = 4.2578 \text{ kc/gauss}$$

For example, if H equals 7000 gauss, the corresponding Larmor frequency is approximately 30 mc. As indicated on the previous page the ratio of the magnetic moment of the proton to that of electron is $\frac{1}{1836}$. The frequency of precession for the electron in a magnetic field is less by this same factor.

Nuclear moments can be detected because they contribute to the total susceptibility. (A paramagnetic substance is one with a positive susceptibility while a diamagnetic material has a negative susceptibility.) The average value of the magnetic moment for each nucleus is:

$$\bar{\mu} = \frac{I + 1}{3I} \left(\frac{\mu^2 H}{kT} \right) \quad \text{if } \frac{\mu H}{kT} \ll 1$$

$K = 1.37 \times 10^{-16}$ ergs/degree (Boltzmann's constant)
 Total magnetization per unit volume, \vec{M} , is μ times number of nuclei per unit volume. Further \vec{M} equals $\chi \vec{H}$ where χ is the susceptibility, for the proton at room temperature:

$$\begin{aligned} T &= 291^\circ \\ \mu &= 1.41 \times 10^{-23} \text{ erg/gauss} \\ N &= 6.9 \times 10^{22} \text{ cm}^{-3} \\ I &= \frac{1}{2} \\ \chi &= 3.4 \times 10^{-10} \end{aligned}$$

So that, if a magnetic field is applied to a paramagnetic substance, there is a total magnetization induced along the axis of the applied field. However this value is not reached instantly after applying a magnetic field but approaches this value exponentially depending on a time constant T_1 .

(For electron resonance the final value is approached in microseconds.)

T_2 for protons may vary from seconds to hours. During this time between application of a magnetic field and final alignment of the nuclear moment, a precession occurs about the external field at the Larmor frequency. The precessing nuclear magnetic moment vector, \vec{M} , is shown in figure 1.

Nuclear induction was obtained at Stanford by the "crossed coils" method. If H_0 is approximately 7000 gauss then the frequency of precession is approximately 30 mc as mentioned earlier. H_0 will be termed the polarizing field. The change to be observed is a voltage produced by the change in orientation of the nuclear moments. If the field H_0 was created by two polarizing coils with their common axis the z axis (or by a magnet similarly oriented) and if to this is added two coils placed with their

axis along the x axis, then we would have the setup shown in figure 2.

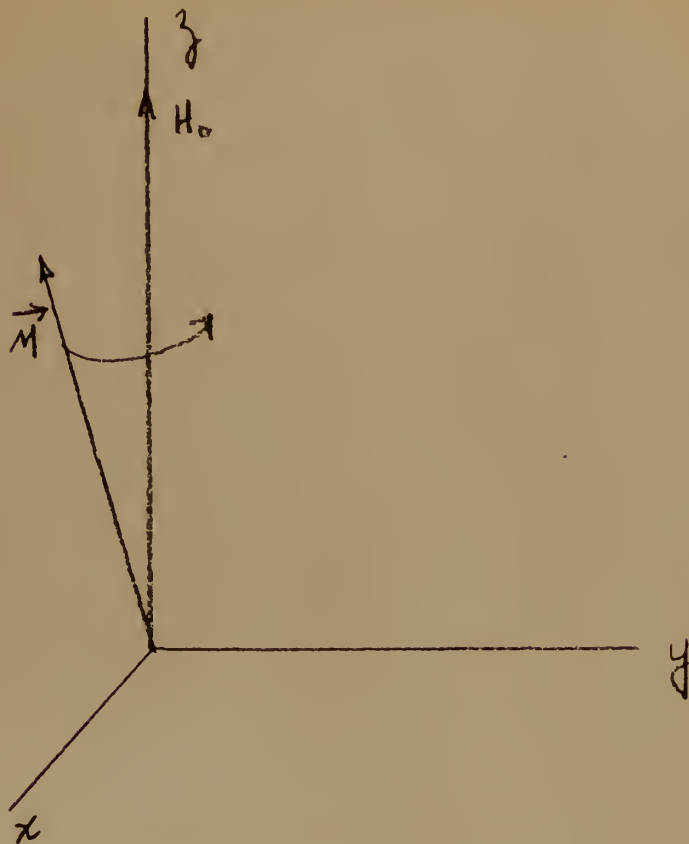

Figure 1. Precession of nuclear magnetic moment about polarizing field.

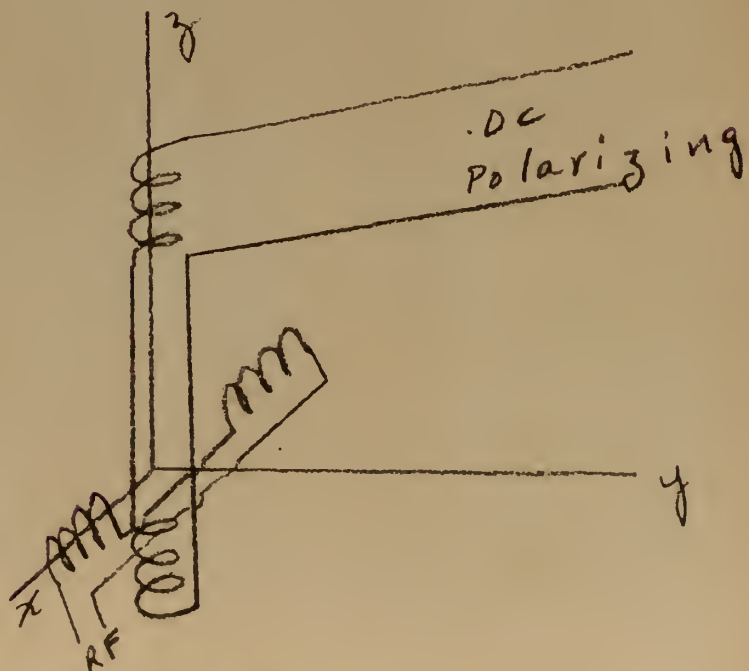

Figure 2. Position of polarizing and R.F. coils

If the coils oriented along the x axis are excited at a frequency near the Larmor frequency of 30 mc, it is possible for the nuclear moment, which has been precessing about the polarizing field H_0 , to absorb energy from the source of R.F. voltage. (The R.F. field is termed the H_1 field and is small as compared with H_0). It is convenient to think of the R.F. as composed of two vectors rotating in opposite directions. Thus, as long as no sample was present to be polarized, the R.F. vectors have components along the x axis but components along the y axis are cancelled to zero. However, the presence of a polarized sample provides a vector which adds to one or the other of the two rotating R.F. vectors depending on the direction of rotation of \vec{M} . This vector, \vec{M} , is initially precessing about the z axis and the angle ϕ , indicated in figure 3 is rather small.

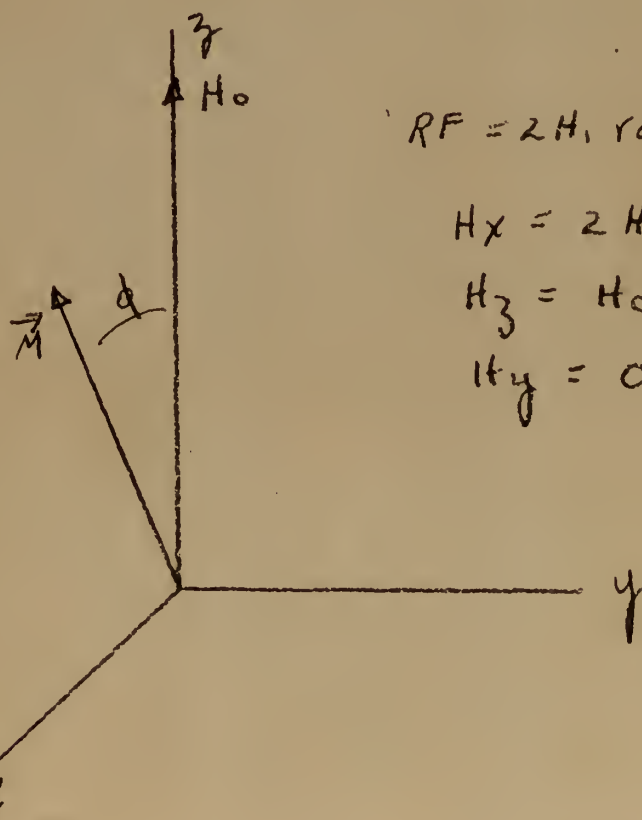

Figure 3. \vec{H}_0 , \vec{H}_1 and \vec{M} vectors

However, as the vector attempts to precess about the field that is the resultant of H_0 and H_1 , ϕ increases so that \vec{M} , at resonance, is rotating in the xy plane and is in phase with one of the two R.F. vectors previously discussed. The R.F. vectors are then no longer equal and so no longer cancel to zero along the y axis.

$$\begin{aligned} \text{If } \vec{A} &= \text{Angular momentum} \\ \vec{T} &= \text{Total Torque} \\ \frac{d\vec{A}}{dt} &= \vec{T} \\ \vec{T} &= \vec{M} \times \vec{H} \end{aligned}$$

Where \vec{M} equals resultant nuclear magnetic moment per unit volume.

$$\begin{aligned} \vec{M} &= \gamma \vec{A} \\ \vec{A} &= \frac{\vec{M}}{\gamma} \\ \frac{d\vec{A}}{dt} &= \frac{1}{\gamma} \frac{d\vec{M}}{dt} \\ \frac{1}{\gamma} \frac{d\vec{M}}{dt} &= \vec{M} \times \vec{H} \\ \frac{d\vec{M}}{dt} &= \gamma (\vec{M} \times \vec{H}) \end{aligned}$$

The above equation describes the time variation to be expected from the polarization vector \vec{M} . It can be seen that the maximum value, i.e., resonance, will occur when \vec{M} is in the xy phase if H_0 is along the z axis. For resonance ω equals γH_0 . If we assume that $\omega_0 - \omega$ is $\ll \omega_0$

and $H_1 \ll H_0$, then

$$H_x = 2 H_1 \cos \omega t$$

$$H_y = \pm 2 H_1 \sin \omega t$$

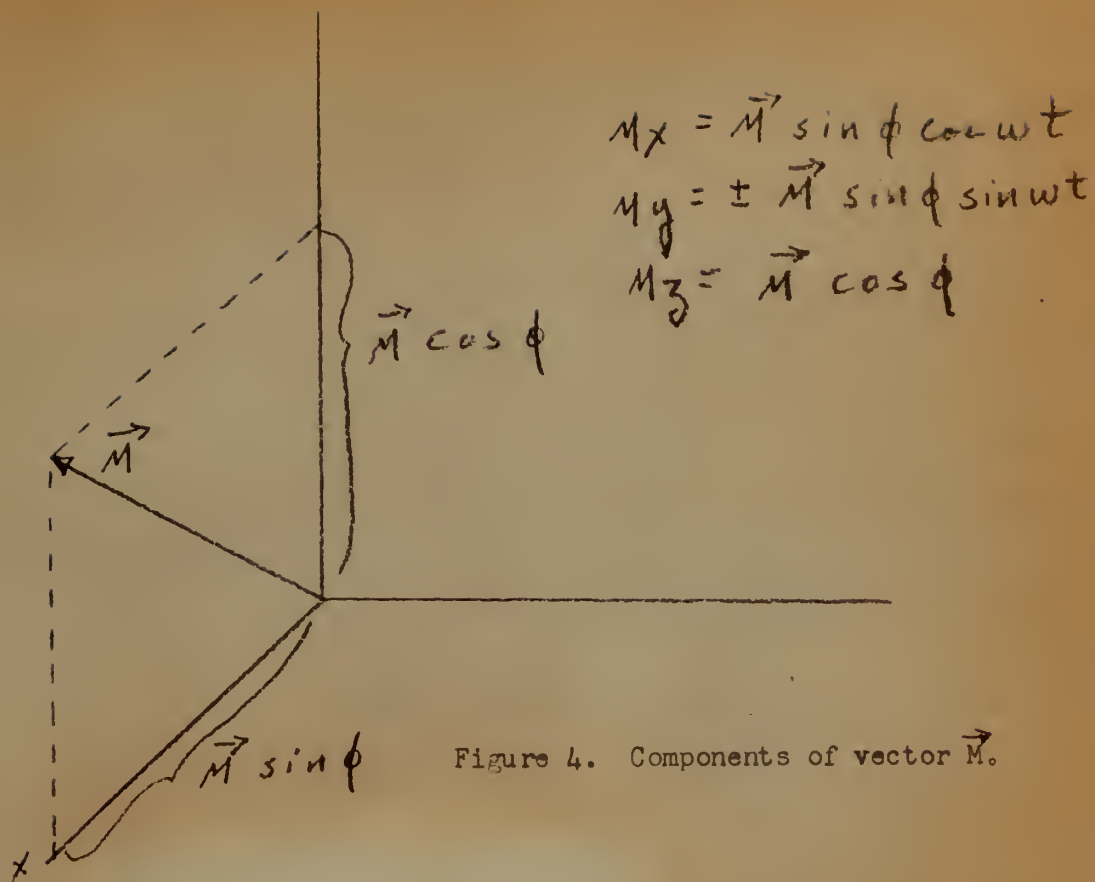

So that when ω equals γH_0 equals ω_0 we have resonance, ϕ equals 90° and $\tan \phi$ equals ∞ . The \pm is used since γ may be either positive or negative in sign.

It is often easier to obtain resonance by having a constant R.F. frequency and start with a value of polarizing field that is near that required for resonance. Then by modulating the amplitude of the magnetic field along the z axis with sweep coils at an audio rate, the nuclear moment \vec{M} can be made to pass thru the xy plane and, hence, resonance, at an audio rate.

If, in addition to these coils already described, there is added still another whose axis is along the y axis, termed the receiving coil, a small signal on the order of microvolts will be induced in the receiver coil by M_y as the vector \vec{M} passes thru resonance.

The transmitter coils, receiver coils, sample, plus certain matching networks are usually contained in an R.F. head called a probe. A photograph of a 30 Mc probe built by the author is shown in figure 6. The signal induced in the receiver coil of this probe is amplified and detected—usually with a crystal detector when working at 30 Mc. The type of presentation of the signal depends on the purpose of the equipment. For magnetometer work in high fields of 7000 gauss for example, an oscilloscope presentation may be satisfactory. Figure 5 shows an oscilloscope picture of the resonance of protons in water. The line width is .1 gauss. It has been determined that the line width can be affected by the addition of certain paramagnetic ions. In this case the solution was .1 molar of $MnSO_4$ in H_2O .



Figure 5. Proton resonance for .1 molar solution of $MnSO_4$ in water.

One of the difficulties in realizing great accuracy with the magnetometer operating in the 30 megacycle region is the difficulty of reading within a line width. The signal shown in figure 5 has a waveform given by Bloch as:

$$\frac{\gamma H_1 T_2}{1 + (\gamma H_1)^2 T_1 T_2 + (\Delta \omega T_2)^2}$$

Where T_1 and T_2 are relaxation time constants and other factors have been previously given. The exact shape is difficult to determine. Further, the narrowest "line" (an electron resonance line) is approximately 20 milligauss or 2000 γ . Therefore, for extremely accurate readings of field strength, the exact position of the resonant peak must be determined to 1 part in 2000 if accuracy to within 1 gamma is desired. The problem of reading within a line is quite complicated because of inhomogeneities that may exist in the field and because of the possibility of assymetry that may exist in the wave shape due to a mixture of u and v "modes" as described by Bloch. (1)

A common and very useful application of nuclear induction is in the field of nuclear spectroscopy. This is a tool used primarily by chemists. For example, the various proton lines of some substance such as ethyl alcohol can be resolved into fine line structure as shown in figure 7. Moving to the right along the abscissa on the tape of figure 7 corresponds to increasing the magnetic field. The total signal occurs within a field change of about 20 milligauss. The technique requires that the intensity of the magnetic field be known to the degree of line resolution desired. The sample being studied is placed in an R.F. head which contains the transmitter and receiver coils plus matching circuits. The R.F. head used to obtain the tape in figure 7 is shown in figure 6.



Figure 6. 30 M.C. R.F. Head

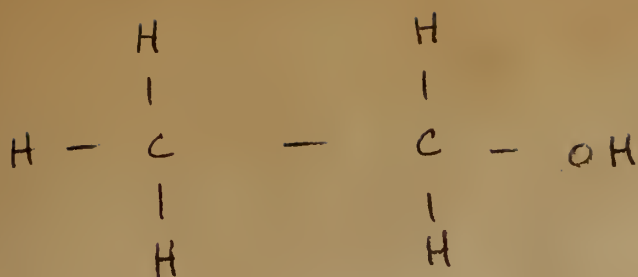

Fine splitting of an ethyl alcohol signal. $\text{CH}_3 \text{CH}_2 \text{OH}$

OH is left hand peak

CH_2 next is a quadruplet

CH_3 next right is a triplet

coupling between electrons of the two carbons causes interaction.

The tape indicates resolution of about 1.5 milligauss.

Figure 7. Nuclear Spectroscopy tape for Ethyl alcohol.

2. A New Type Magnetometer

In nuclear spectroscopy work the relationship ω equals γH is made use of in determining fine line structure. This same relationship can be used in magnetometer applications. For a given frequency the magnetic field H required to produce resonance in the protons of water is well known. Thus we have the inherent possibility of being able to measure field strength H by measuring frequency ω . This fact is made use of in magnetometers working in high fields and at R.F. frequencies with little difficulty since information to within .1 gauss is usually sufficiently accurate. A magnetometer that will operate in small fields with comparable accuracy is more difficult to come by. One approach to the problem was to make use of electron resonance. For the fixed frequency of 30 Mc, proton resonance occurs at about 7000 gauss while electron resonance occurs in fields of only a few gauss for the same frequency. This possibility, the use of electron resonance for low field measurement, was investigated by Levinthal and Rodgers. (4) They found that accuracy of $\pm .02$ gauss or $\pm 2000 \gamma$ could be obtained.

The material that follows will describe a new technique that utilizes the free precession of protons in water to measure the small magnetic field of the earth. In this method a sample of water is polarized with a large magnetic field (large as compared with that of the earth). This polarizing field is oriented approximately 90 degrees to the earth's magnetic field. It is necessary to polarize the sample of water with a field H_0 in order to orient the vector \vec{M} approximately 90 degrees to the earth's field. The reason for this will become more apparent later.

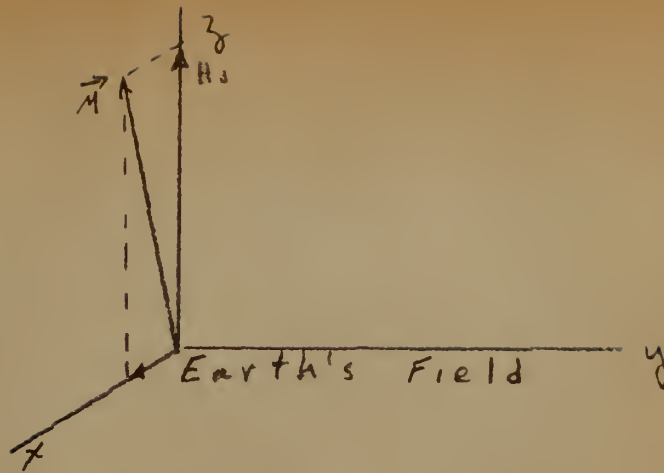

Figure 8. Direction of vector \vec{M} after polarization.

The polarizing field H_0 is left on for a time long as compared with T_1 , where a time equal to $5 T_1$ is required for alignment of the induced moment \vec{M} approximately along H_0 . After $5 T_1$ \vec{M} would actually be aligned along a line that is a resultant of H_0 and the earth's field but if H_0 is much greater than the earth's field then the vector \vec{M} would be positioned approximately along H_0 .

If this large polarizing field is now suddenly cut off, the vector representing the overall magnetic moment is left free to precess, with exponentially decreasing amplitude, about the only magnetic field remaining, that of the earth.

\vec{M} will precess about the earth's field in the same way that it precessed about H_0 immediately after H_0 was impressed. However, the frequency of precession is quite different in the two cases because H_0 is much greater than the earth's field and the frequency of precession is definitely related to field strength as shown by the equation for ω equals γH on Page 7 which leads to a precession frequency of:

$$f = 4.2578 \text{ Kc} \times \text{field in gauss}$$

Thus, for the 30 Mc probe discussed earlier, the field associated with it was about 7000 gauss. Now, however, with the earth's field of .5 gauss, the frequency of precession is seen to be an audio frequency just over 2 Kc.

If a receiving coil were placed 90 degrees to both the earth's field and the polarizing field, a small signal of a few microvolts would be induced in it by the precession of the vector M^z about the earth's field after H_0 was cut off.

An important factor in practical application of this equipment should be noted here. It is not necessary that H_0 be exactly 90 degrees to the earth's field in order to determine the frequency of precession and thus the earth's field strength. If H_0 is not 90 degrees to the earth's field, then the amplitude of the signal induced in the receiving coil is reduced but its frequency is unchanged. Thus, if H_0 is 45 degrees to the earth's field, the ultimate signal is reduced to .7 of its previous amplitude but its frequency remains the same.

If the signal induced in the receiving coil after the magnetizing field is turned off is amplified, and the exact frequency determined, it would be possible to thus obtain a measure of the earth's magnetic field. A block diagram of the required equipment is sketched in figure 10.

It has been shown by Bloch (1) that the signal to noise ratio is proportional to the volume of the sample. This is true because the greater volume provides a larger number of dipoles. Therefore a fairly large sample should be used.

In nuclear spectroscopy the line resolution possible is limited by inhomogeneities in the big magnetic field, H_0 . For example, if the field

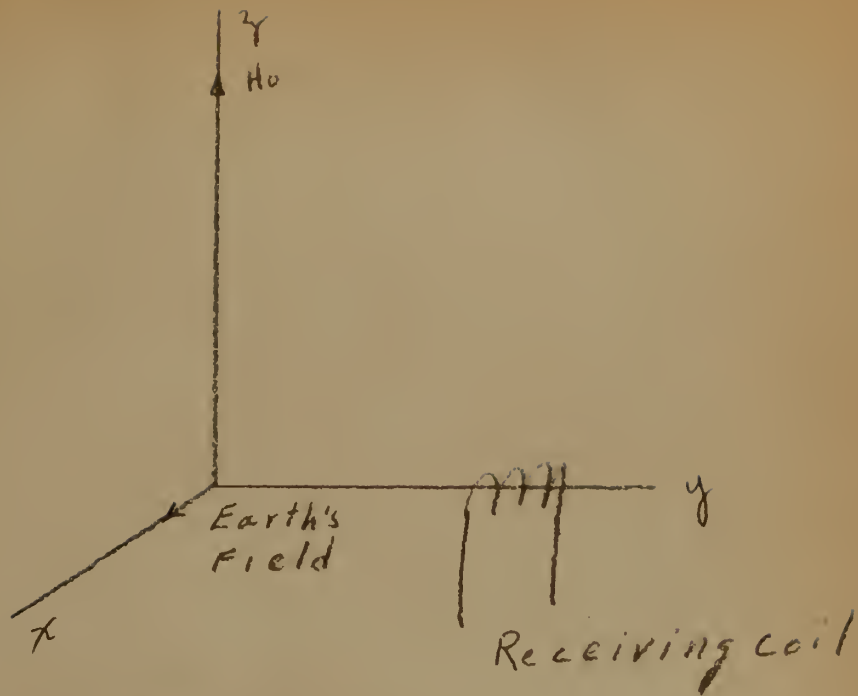

Figure 9. Orientation of receiving coil.

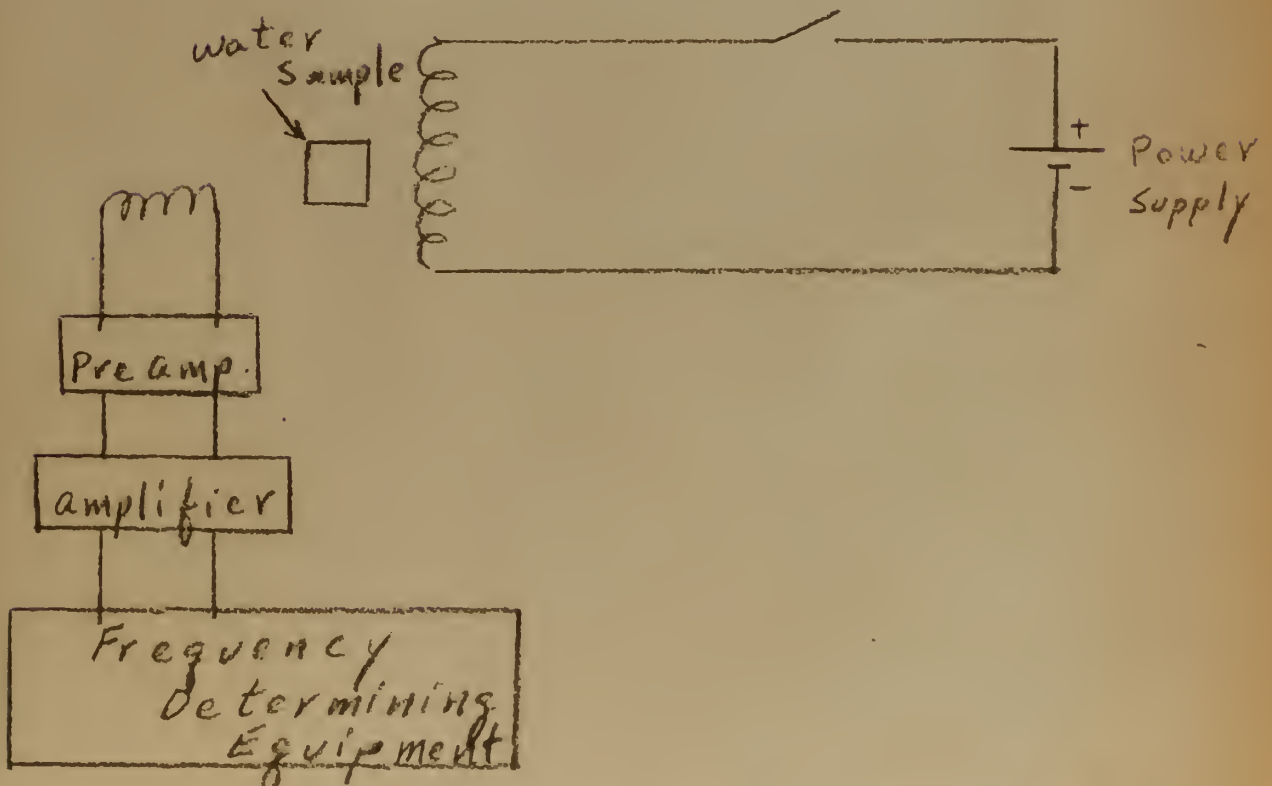

Figure 10. Block diagram of Earth's magnetic field measuring equipment.

across the sample is homogeneous to within .001 gauss, then spectrum lines separated by less than .001 gauss cannot, in general, be resolved. Since it is difficult to create a magnetic field of 7000 gauss that is homogeneous over a large area, the samples used in spectroscopy are necessarily small, being on the order of one cubic centimeter. However, the earth's magnetic field is homogeneous over a very large area and this makes it possible to use quite large samples and thus obtain better signal to noise ratios.

The polarizing coil should be capable of providing a magnetic field of at least 100 gauss in order to produce a magnetic field that is 200 times that of the earth's magnetic field.

The open circuit voltage, which can be considered as being introduced in series with the coil has been shown by Packard (7) to be:

$$V_{\text{open circuit}} = 4\pi N A M \omega \cos \omega t \times 10^{-8} \text{ volts}$$

N = number of receiver coil turns

A = area of cylindrical sample in cm^3

M = χH

= susceptibility $\times H = 3.4 \times 10^{-10} H$

H_0 = 100 gauss polarizing field

N = $6.9 \times 10^{22} \text{ cm}^{-3}$

μ = $1.4 \times 10^{-23} \text{ erg/gauss}$ = magnetic moment for each nucleus

K = $1.37 \times 10^{-16} \text{ erg/degree}$ = Boltzman's constant

T = 291° = absolute temperature in degrees Kelvin for room temperature

The voltage across the capacitor shown in figure 11 which is the voltage applied to the grid of the first stage of the preamplifier is Q times V_{oc} . The rms value of the grid voltage is $Q \frac{V_{oc}}{\sqrt{2}}$ where Q is the Q of the

receiver coil. For the above values the maximum rms volt. at the grid is: $V_{rms\ max}$ equals $41.6\ NAQ$ micro micro volts.

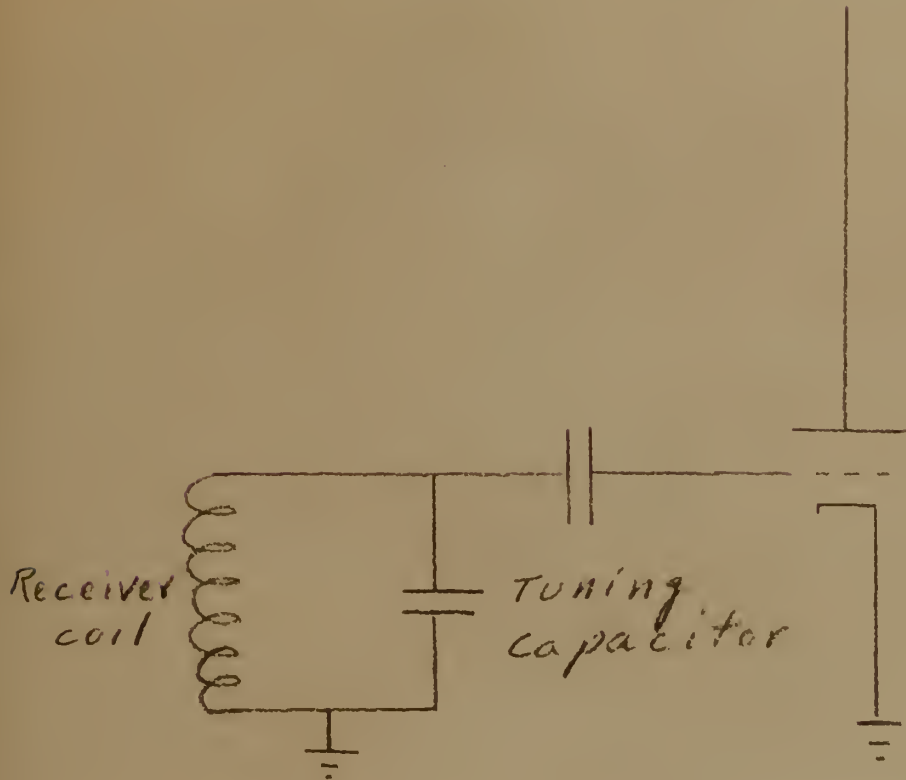

Figure 11. Input to first stage of preamplifier.

Therefore, in order to theoretically have an input signal of 41.6 microvolts, NAQ must equal 10^6 . Thus, a large number of receiver coil turns, a large sample area, and a high Q is desirable.

In the counting circuit, to be described later, it is possible for noise to cause an erroneous count. Therefore, it is desirable to reduce noise to as low a level as possible while still retaining the signal.

The signal was centered about a frequency of 2182 cycles. A shift of 1 cycle would correspond to a shift in the earth's field of approximately 25γ . Diurnal fluctuations based on data from the Coast and Geodetic Survey's station at Tucson, Arizona, are about 40γ , corresponding to less than two cycles. Large magnetized material near the equipment could cause somewhat greater fluctuations than this but it is apparent that a very narrow band amplifier is feasible. Noise N equals $4KT\Delta f$ where Δf represents the bandwidth. A bandwidth of a few cycles seems advisable. However, a very narrow bandwidth brings in other considerations. If a sine wave is impressed on a tuned circuit with a given Q , the ensuing oscillations do not commence at maximum amplitude instantly but build up exponentially to their maximum value in $\frac{5Q}{\pi}$ cycles of the impressed sine wave.

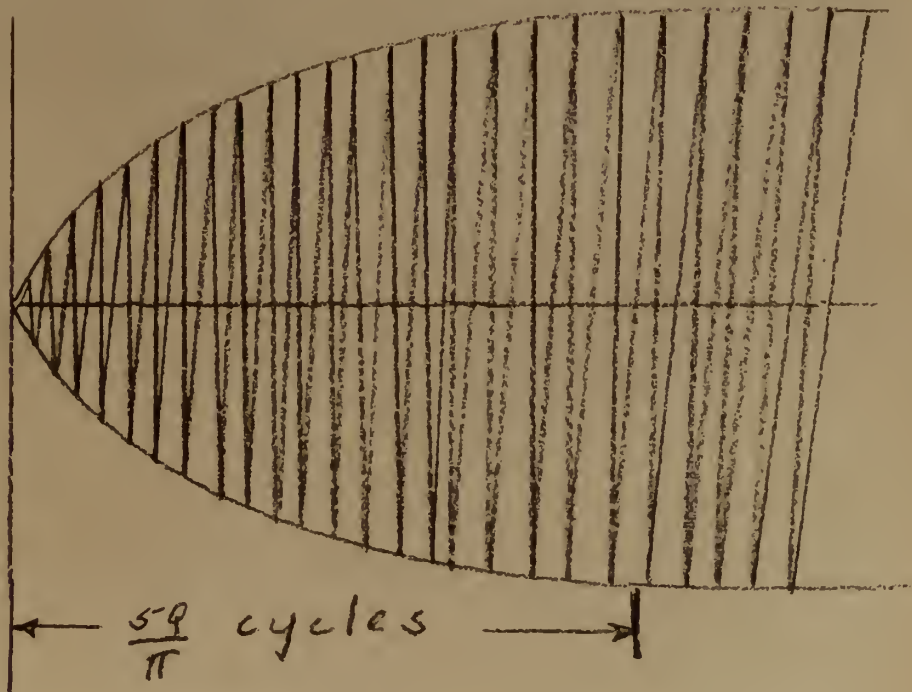

Figure 12. Exponential rise of sine wave signal impressed on a high Q circuit.

The signal occurring in the receiving coil is an exponentially decreasing sine wave $A e^{-\lambda t} \sin \omega t$. If this signal were applied to a low Q circuit it could be expected to build up very rapidly while if it were applied to a very high Q circuit it would build up more slowly. Since the time constant of the exponential decay was approximately 1.6 seconds, it was important that the signal not build up too slowly for, if it did, it would be decaying into noise before a satisfactory count could be obtained. This problem was investigated with Laplace transforms and is included as appendix I. The results showed that for a Q equal to 200, i.e., a bandwidth of approximately 10 cycles, the envelope of the waveform produced would be as sketched below.

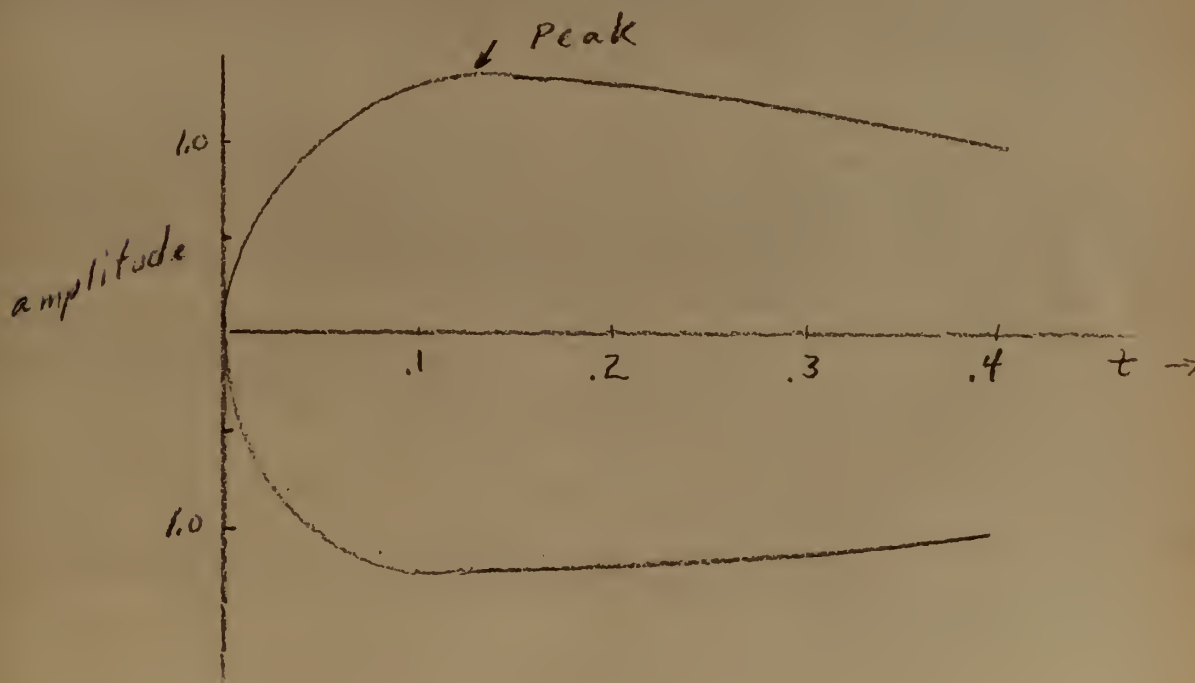

Figure 13. Waveform produced by signal $A e^{-\lambda t} \sin \omega t$ Impressed on a circuit with a Q of 200.

The waveform shows that the transient condition caused by the high Q circuit lasts only about one-tenth of a second which is not serious since the total counting time expected to be available before the signal decays into the noise is approximately two seconds.

The frequency of precession could be determined in various ways. One direct way that immediately suggests itself is to amplify the signal to sufficient amplitude and count the frequency with some device such as a Hewlett Packard 524A counter. The H.P. 524A will count a 2 Kc audio frequency by more than one method. It will count for 1 second of the signal frequency with an uncertainty in the count of 1 cycle of the signal frequency which corresponds, for a one second count, to an uncertainty in the earth's field of 25γ . Another method of counting possible with the H.P. 524A is to use the signal frequency, the 2 Kc, to gate on and off a 100 Kc crystal controlled frequency that is generated inside the H.P. 524A. In its normal use the gate would be kept open for 10 cycles of the signal frequency during which 500 cycles of 100 Kc is counted with a possible error of 1 cycle out of 500. Therefore, the count must continue for much longer than 10 cycles of the signal frequency if accuracy on the order of 1γ is to be obtained. If the count were continued for 4000 cycles of the signal frequency, 2 seconds of time, the number of 100 Kc cycles occurring between the gating on and gating off pulses would be approximately 200,000 and the uncertainty of one count in the 100 Kc would correspond to a $\frac{1}{4} \gamma$ uncertainty in the earth's field.

It might seem at first glance that the count should be continued as long as any signals were available to count. This is not true because of noise bursts that can occur and cause errors in the counting. The accuracy

will decrease by a factor $1/e$ each time the range is doubled after reaching some S/N ratio that first causes some small error to exist in the counting. This is the "critical" S/N ratio. Thus there are two opposing effects--one that produces a factor of two improvement in accuracy each time the range is doubled; the other a $1/e$ decrease in accuracy each time the range is doubled after reaching the critical S/N ratio. The count should always be continued to the critical value of S/N and to $.567$ of one time constant thereafter. This conclusion is justified in appendix II.

CHAPTER IV

EXPERIMENTAL EQUIPMENT

The following system components will be described:

1. Polarizing coils
2. Receiving coil
3. Sample of water
4. Preamplifier
5. Amplifier, Narrow Band
6. Gating and counting circuits
7. Analoging circuit

1. Polarizing coils

These two coils each consisted of 1200 turns of #18 wire. The D.C. resistance of each coil was 25 ohms. They were wound on drum-like coil forms that could be moved relative to one another. The total inductance when the coils were placed as close together as possible was 1 henry. The field created by the coils with two amperes of current flowing was 172 gauss which is 244 times that of the earth's field. This field meets the requirement of being large as compared with that of the earth. The inside diameter was 8" which permitted use of a quite large water sample. It was necessary to polarize the coil by supplying current for a period of several seconds in order to allow the sample sufficient time to reach its steady state of maximum magnetization. Following this the current must be cut off. This switching was accomplished by a microswitch actuated by a slowly rotating wheel containing two notches.

The wheel rotated at 2 rpm which permitted one cycle of polarize and then count during each 15 second period. A schematic diagram of the

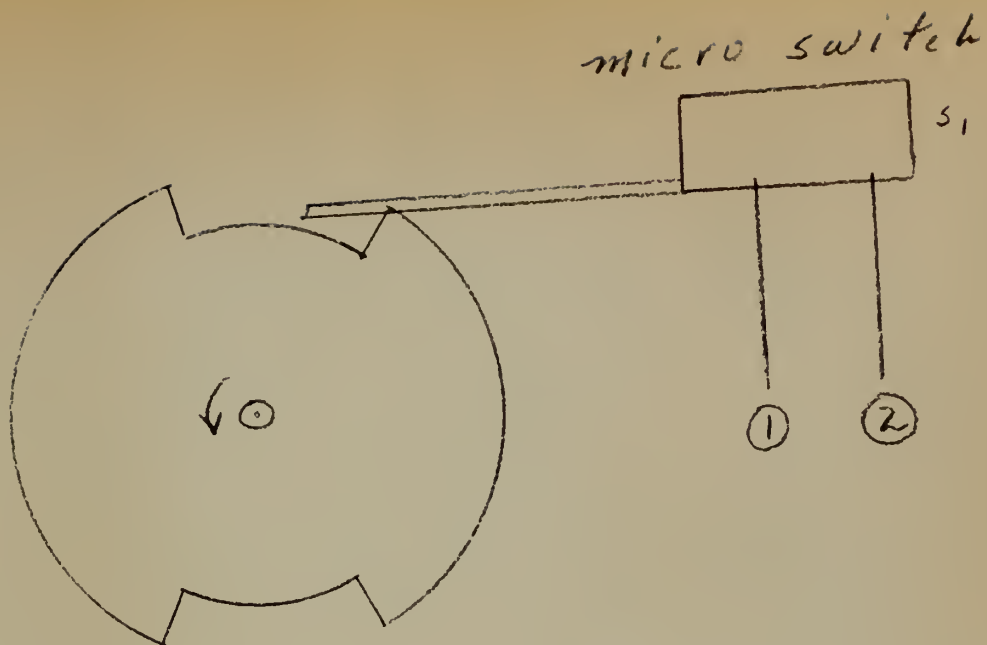

Figure 14. Timing wheel.

polarizing coil circuit is shown on page 28. Terminals 1 and 2 are also indicated in the figure.

The sequence of action was as follows: when the microswitch was out of the notch, s_1 was closed. This in turn closed s_2 and s_3 . These relays caused s_4 and s_5 to close. In this condition, which lasted for approximately 10 seconds, the power supply provided two amperes of current to the polarizing coils and the water sample was thereby polarized. As the rotation of the wheel continued, the microswitch arm dropped into the notch causing s_1 to open. Switches s_2 , s_3 , and s_4 open immediately leaving the polarizing coils in series with a resistor R_1 (220 ohms) and a capacitor c_1 (80 μ f). This causes an overdamped pulse of current to flow in the polarizing coil whose duration is approximately 20 milliseconds.

There is a delay of several milliseconds between the opening of s_2 , s_3 , and s_4 , and that of s_5 . C_2 was 80 μ f and R_2 was approximately 31 K.

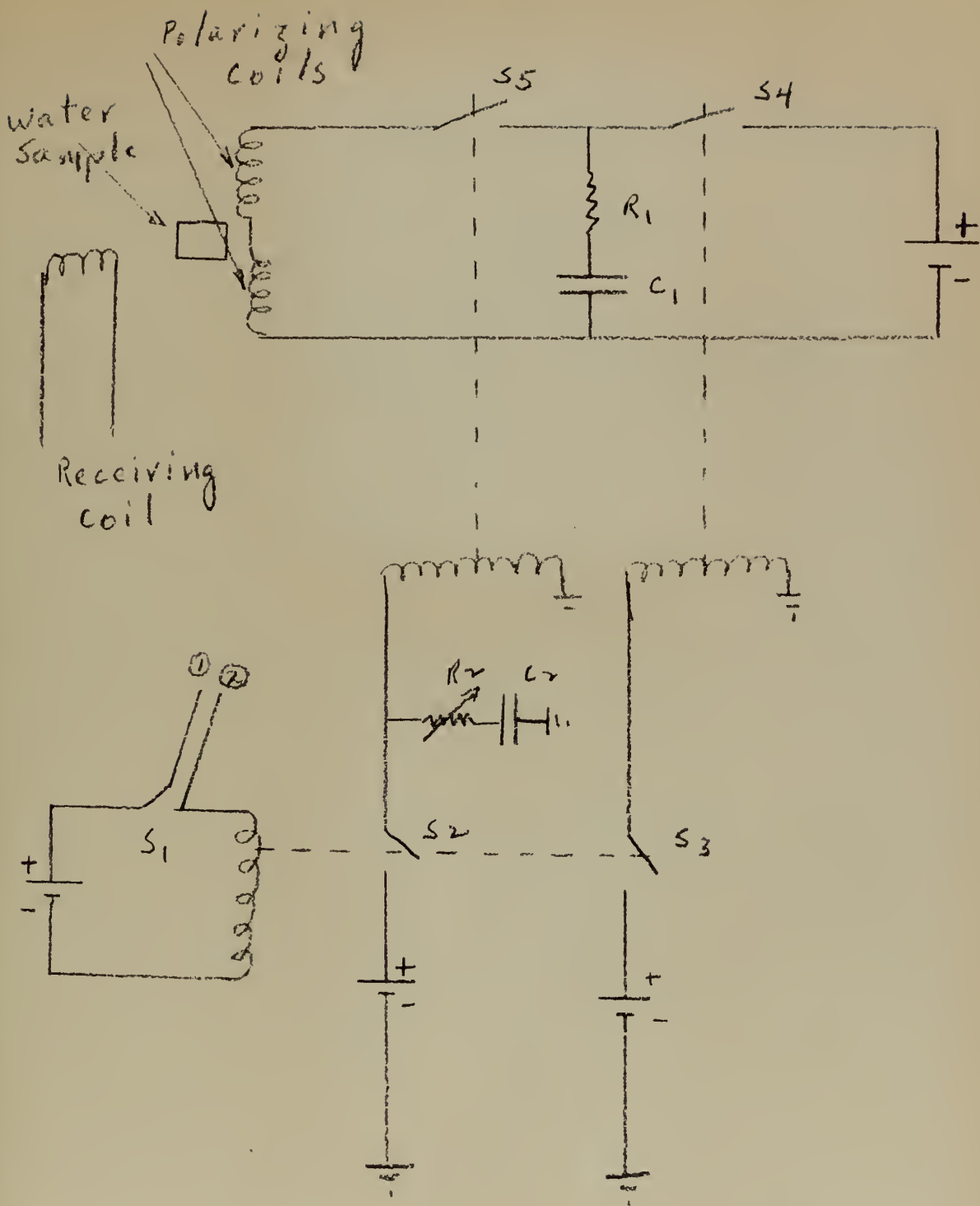

Figure 15. Polarizing coil circuit.

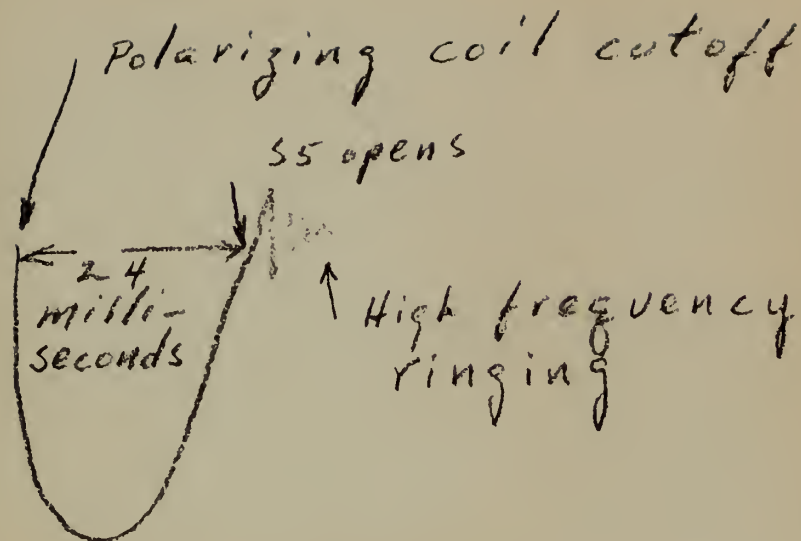

Figure 16. Transient response of polarizing coil.

The opening of s_5 leaves the polarizing coils free to ring at the high frequency but low amplitude determined by the inductance of the coils and their distributed capacitance. See figure 16. The voltage rises initially then decays for 24 milliseconds before the high frequency ringing commences. This two-step cutoff was devised by Varian and greatly simplifies the transient problem. This is true because large transients in the polarizing coils induce large, unwanted signals in the receiving coil which block the amplifying stages and cause ringing of the high Q circuits.

2. Receiver coil

This coil was 4" long and had a 3.5" inside diameter. It consisted

of 3500 turns of #26 wire and had an inductance of .235 henry. The D.C. resistance was 95 ohms. The A.C. resistance equals the D.C. resistance at the audio frequency of 2 Kc.

$$Q = \frac{\omega L}{R} = 34$$

Sufficient capacity to resonate the receiving coil was placed across it.

In the cutoff of the polarizing coils it is desirable to have a rapid cutoff so that the many small nuclear moments which combine to form the vector \vec{M} will start precessing in phase and thus produce a coherent signal. Experience has shown that if cutoff is too rapid a smaller signal results. This is tentatively accounted for by a fanning out of the nuclear moments that combine to form \vec{M} with a resultant destructive phase interference.

On page 20 the equation for the maximum rms voltage at the grid of the first stage of the preamplifier was given. It depended on several factors such as the Q and number of turns of receiving coil, magnitude of polarizing field, area and susceptibility of sample and frequency of precession. Using the values just given in the description of the polarizing coils and receiving coil, the theoretical value of maximum rms voltage to be expected at the grid of the first stage of the preamplifier is 1.8 millivolts. (The sample area used was 213 sq. cm.)

Later, it was desired to check this value of 1.8 millivolts at the grid of the first stage of the preamplifier to see how it compared with the amplitude of the signal at this point obtained from an actual water sample. In order to accomplish this a water sample was polarized and then allowed to precess about the earth's field. The output amplitude

after preamplification was observed on an oscilloscope. An artificial signal from a signal generator was then introduced at the first grid of the preamplifier and its amplitude at that point adjusted until the preamplifier output as shown on the oscilloscope was the same as that obtained with the actual signal. By this substitution method it was found that the signal from the actual sample of water produced a voltage of .1 millivolt at the grid of the first stage of the preamplifier rather than the computed value of 1.8 millivolts. The reason for this difference is not fully understood. Possible explanations include the fact that the equation used is for a long cylindrical sample which did not in fact exist. Further, signal reduction can be caused by coil orientations that are not optimum.

3. Water sample

This was enclosed in a glass jar that was fitted inside the receiving coil, so that the coupling would be close. The actual sample area was 3" or 7.62 C_m in diameter and 3.5" or 8.9 C_m long.

"A" equals area of sample and was 213 sq. cm. Volume of sample was 1620 cm^3 . This can be compared with approximately 1 cm^3 samples that are used in most spectroscopy work. Thus a great many more nuclei are being polarized here and the resulting signal is larger than that obtained in spectroscopy work.

4. Preamplifier

This device was placed near the transmitting and receiving coil. It was built of miniature tubes and was powered with batteries on both filaments and B+ to reduce noise and 60 cycle hum. The schematic diagram is shown below. All tubes were ck 628 Ratheon miniatures.

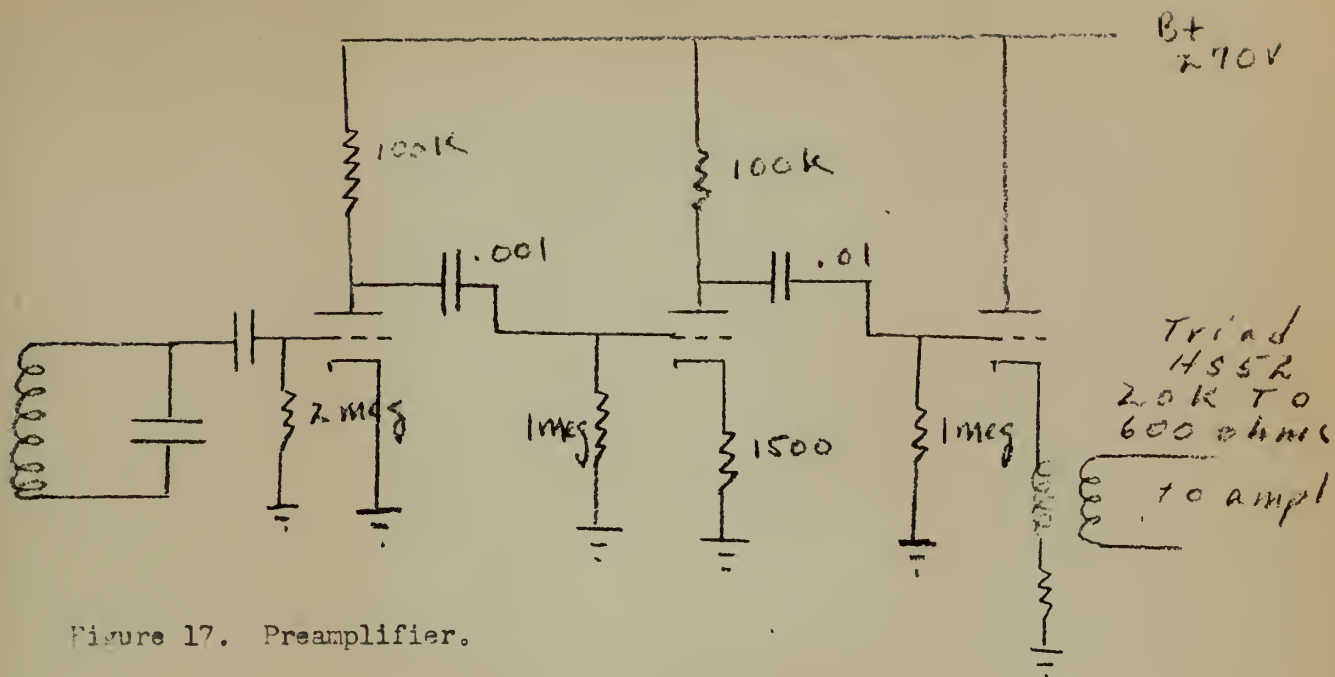

Figure 17. Preamplifier.

This preamplifier provided amplification of the signal from .1 millivolt to 7 millivolts. Thus, the gain was 37 db.

5. Narrow band Amplifier

There were no tuned circuits placed in the preamplifier so narrow banding was required in the amplifier in addition to further amplification. The required amplification could be obtained with one or two additional stages. However, it was desirable to have an amplifier whose bandwidth could be changed readily in order to observe the effect of narrow banding on the signal. With this in mind a narrow band, Q multiplier circuit (3) was constructed.

The Q multiplier circuit consists of a cathode follower that has a tuned circuit at the grid. It has an adjustable positive feedback thru resistor R.F. shown in the schematic diagram, figure 15.

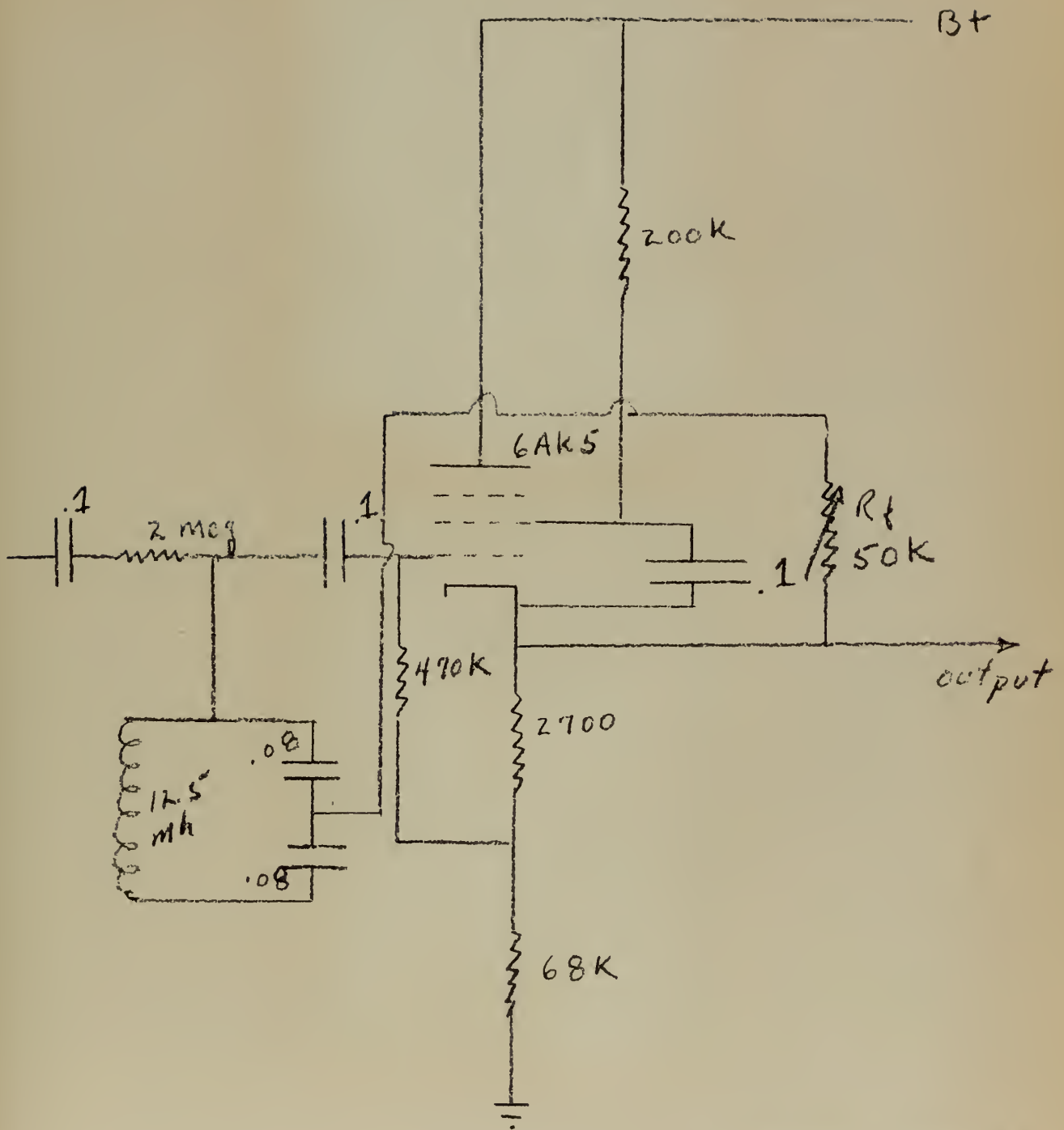

Figure 18. Q multiplier circuit.

Oscillation will occur in a circuit with positive feedback only if Ak equals one, i.e., if the gain times the feedback factor equals one. In a cathode follower the gain is somewhat less than one. Therefore, by keeping the feedback also just slightly less than one, the feedback can be kept below a critical value that would cause oscillating to ensue. The feedback provides, in effect, a negative resistance that cancels a part or the equivalent parallel resistance of the tuned circuit thereby increasing its Q . It was found that Q 's of 2000 were possible at 2 Kc signal input with a resulting bandwidth of 1 cycle. With the circuit shown in figure 18 a bandwidth of 28.7 cycles was measured for an input frequency of 2182 cycle with resistor R_f all in. As R_f was reduced, the Q of the input circuit increased to 200 while retaining good stability.

It was found that if the Q was increased to 570 a slight overshoot due to instability occurred when a sine wave was suddenly impressed. This is shown in the three photographs of figure 19. The first photo shows the signal that resulted when the feedback resistor was disconnected. The rise of signal to final amplitude was very rapid. (Signal was supplied by Hewlett Packard audio signal generator). The Q of the tank circuit at the grid of the tube when considered alone was found to be 57. The second picture shows the rise due to impressing a wave on the circuit with R_f adjusted so that the Q was increased to 200. There is a measurable rise time evident as would be expected. In the third photo the Q was 570 and some overshoot is evident. Q 's used during the tests never exceeded 275.

It is obviously impossible to read the bandwidth of a circuit with a Q of over 500 from the frequency dial of an audio signal generator when the center frequency is 2182 cycles. The bandwidth measurements were

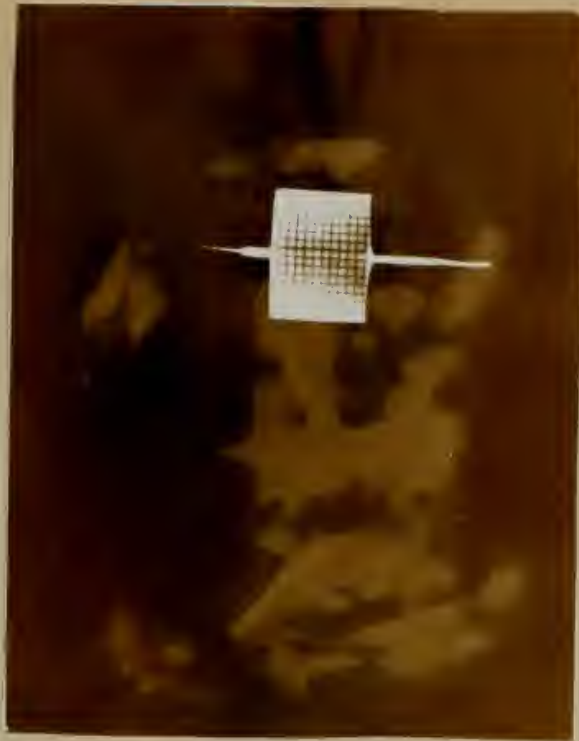

Figure 19. Photographs showing result of impressing a sine wave on a high Q circuit. (Continued on next page)



Figure 19. Photographs showing result of impressing a sine wave on a high Q circuit.

made by H.P. 524A counter plus the binary scaling circuit which was constructed to be used as an integral part of the overall system. This counting system will be described in the next section.

Having constructed a circuit to provide a narrow bandwidth it was also necessary to have two untuned stages of amplification in order to have an output signal of approximately 10 volts maximum amplitude.

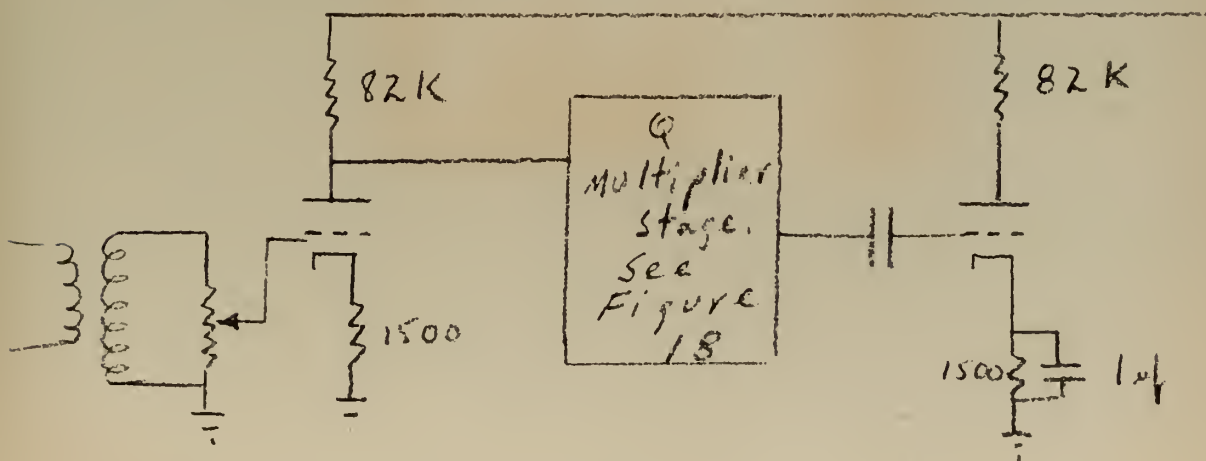

B+

Figure 20. Narrow band amplifier.

6. Gating and Counting circuits

There is available out of the amplifier a signal of frequency near 2182 cycles. Its initial amplitude is approximately ten volts and it is exponentially decaying with a time constant of approximately 1.6 seconds. It has an initial S/N ratio of 20 or 30 to 1. During the 1st 100 milliseconds a transient condition exists that must be avoided. The frequency of this signal must be determined to within a small fraction of one cycle.

The H.P. 524A required .85 volts of input signal to trigger the first squaring and amplifying stages. An input signal sine wave greater than .85 volts would (with the frequency-period switch set to period) produce positive rectangular pulses (shaped signal pulses) of about 30 volts amplitude at pin one of the decade divider socket. This decade divider then supplies output pulses to pin 2 of the same socket that are 1/10 the frequency of the incoming signal. These pulses act as gating pulses for the internally generated 100 Kc. This decade divider was removed and the positive rectangular pulses into pin 1 were inverted and utilized to trigger a binary gating counter. This binary circuit produced pulses spaced 4096 cycles apart or, by switching out one or more stages, it would provide pulses 2048, 1024 etc. cycles apart. The reason for using the binary circuit was to reduce the last count error to a value equivalent to approximately $\frac{1}{4}$ γ change in the earth's field as discussed on page 24.

The schematic diagram of the binary circuit is shown on the next two pages.

The binary scaling circuit consisted of 13 stages which would actually permit output pulses to be spaced by as many as 2^{13} or 8192 cycles, though this number was not used.

a 6527 UNIT

C_1 40 μ f	T_1 6H6
C_2 .01 μ f	T_2 6SL7
R_1 100K 1W	R_4 1.0M $\frac{1}{2}$ W
R_2 33K $\frac{1}{2}$ W	R_5 470K $\frac{1}{2}$ W
R_3 68K 1W	R_6 (B) 40K $\frac{1}{2}$ W

a 65N7 UNIT

C_1 50 μ f	T_1 6H6
C_2 .01 μ f	T_2 6SN7
R_1 18K 2W	R_4 200K $\frac{1}{2}$ W
R_2 4700 $\frac{1}{2}$ W	R_5 100K
R_3 15K 2W	R_6 10K 1W

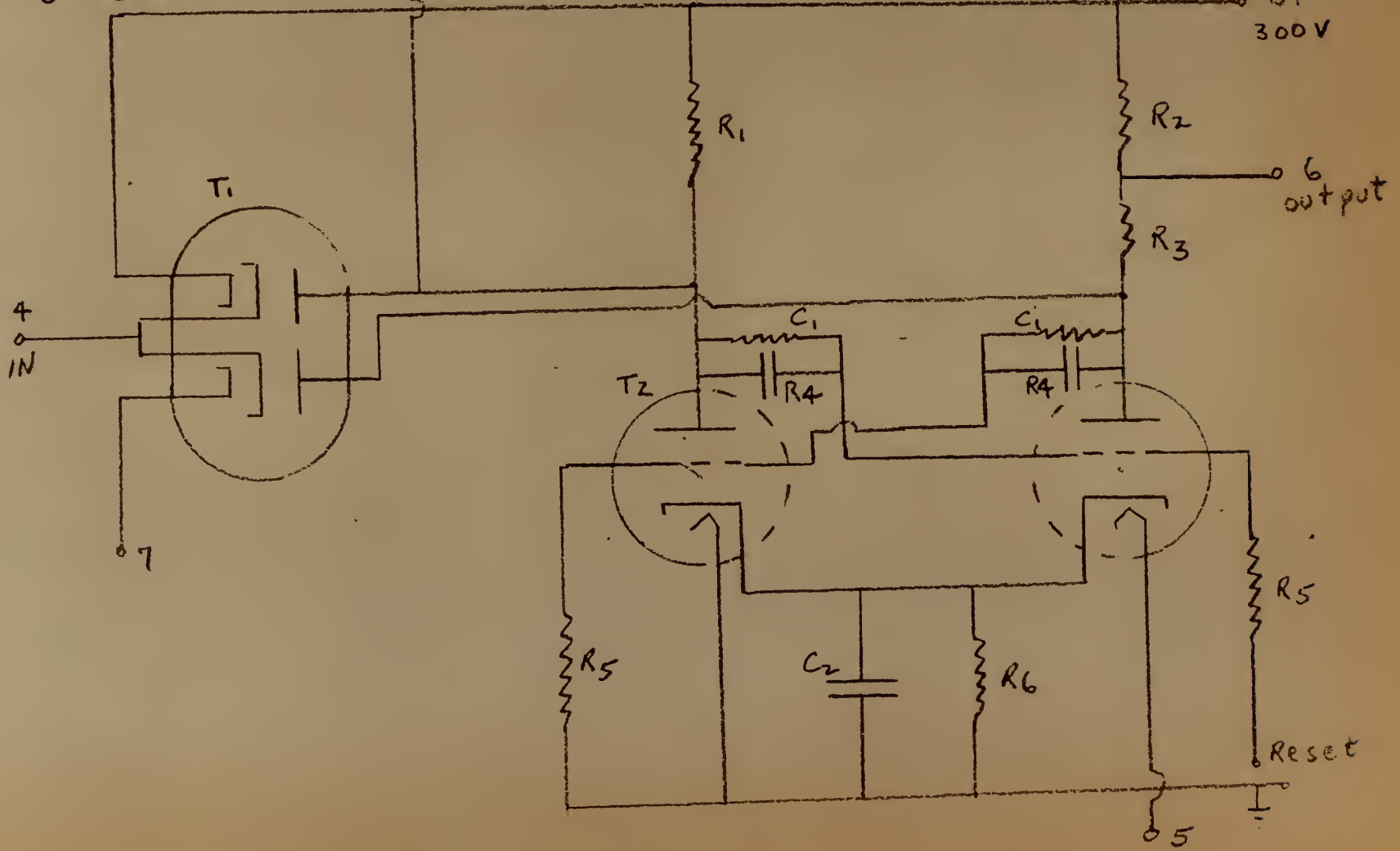

Figure 21. One stage of binary circuit

1st two stages are 6SN7 then 6SL7

B $\xrightarrow{6.3V}$ ac

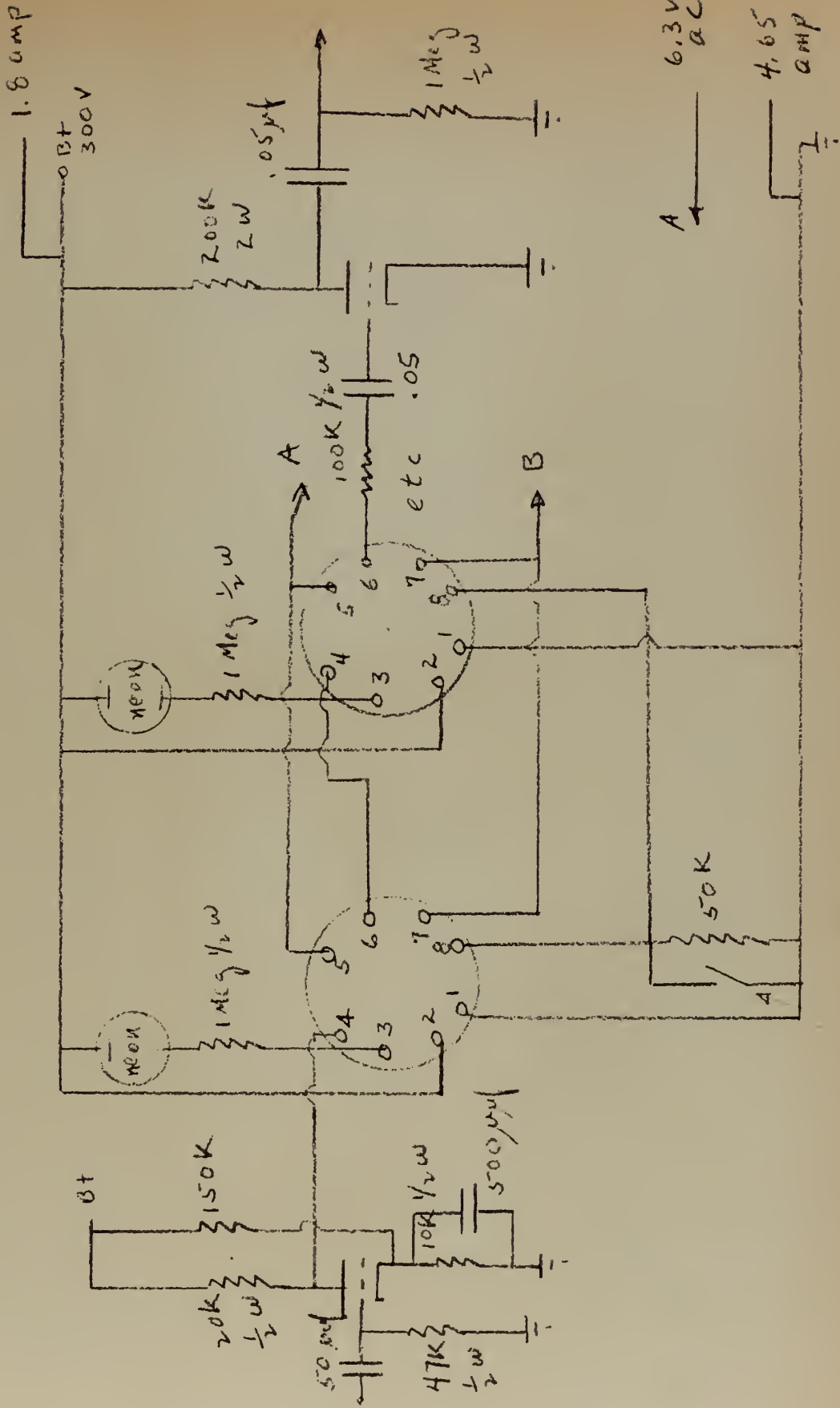

Figure 22. Binary gating counter.

It was important that the counting not commence until 100 milli-seconds after the polarizing coil was cut off in order to avoid a transient condition. (See page 23 and Appendix I) However, no further delay was desirable if the maximum counting time was to be utilized. The delay was introduced by placing a second microswitch so that it was on the opposite side of the slowly rotating wheel from the polarizing coil micro-switch.

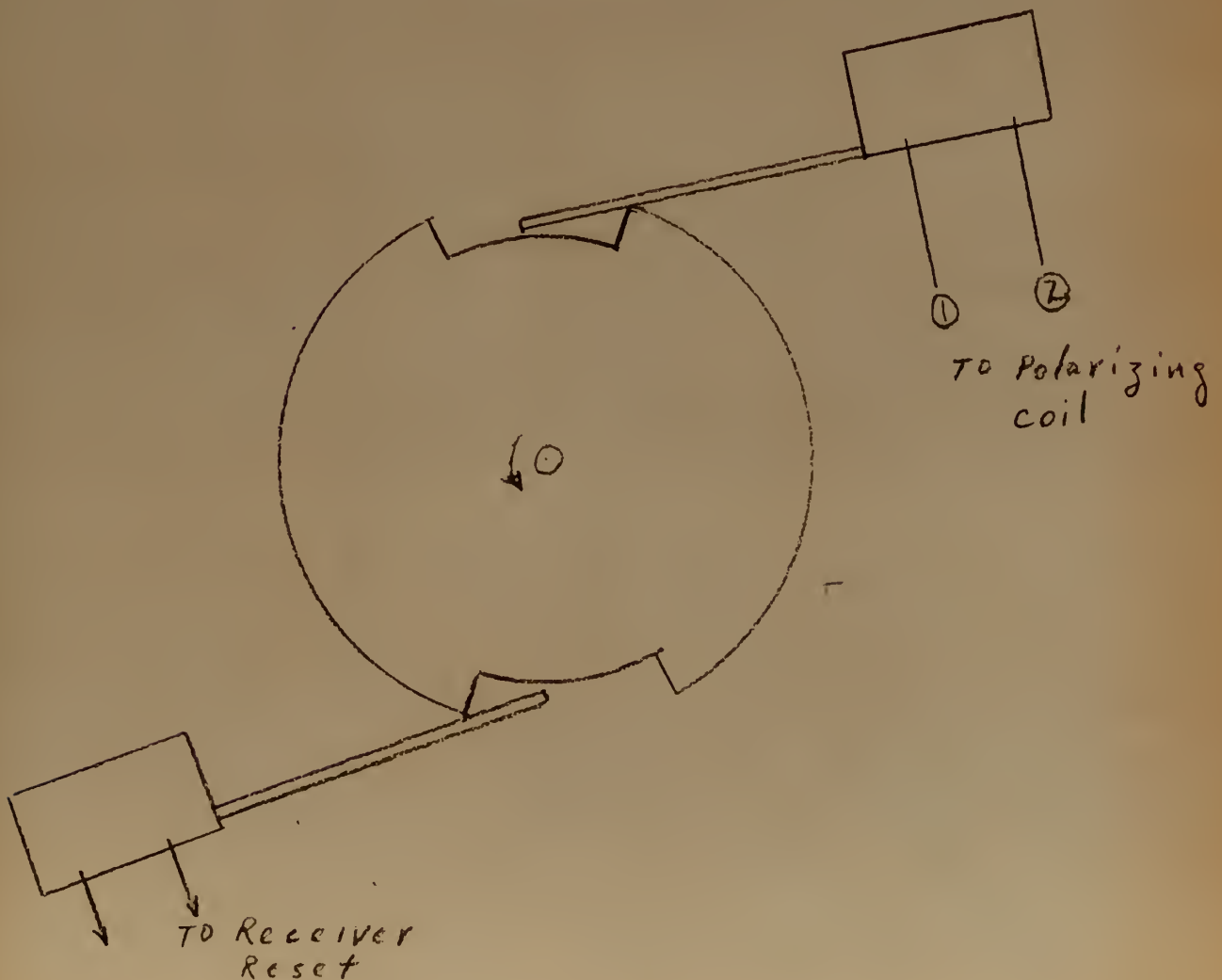

Figure 23. Timing wheel.

The physical position of the second microswitch was arranged so that it dropped into the notch 135 milliseconds after microswitch #1. This introduced sufficient but not excessive delay. The second microswitch caused a relay to open and close that was connected to the reset of the binary gating counter. By dropping into the notch, switch s_6 in drawing 22 was closed bypassing the 50000 ohm resistor. When microswitch #2 was out of the notch, the 50000 ohm resistor was placed in series with the grid resistor in one stage of each of the pairs of bistable circuits in the binary gating counter. This unbalanced each pair and caused each of the stages which had 50000 ohm introduced to become the "on" tube of its pair. The first squaring amplifier of the H.P. 524A counter limited its output to 20 volts regardless of input signal amplitude. This output when fed to the binary gating counter out of pin 1 of the "Decade Divider Socket" was not sufficient to trigger the binary gating counter provided s_6 was open with the 50000 ohm in the grid lead of every other stage. Therefore large transients which occurred prior to the time that microswitch #2 dropped into the notch did not start an erroneous count.

When microswitch #2 dropped into the notch closing s_6 and bypassing the reset resistor, the binary gating counter was ready to receive input signal pulses. It was necessary for the first input pulse to produce an output pulse which would open the gate on the 100 Kc and start a count on the H.P. 524A counting stages. Since this was true, the binary gating counter was not arranged in the conventional manner. If it were, then the first output pulse would occur only after 4096 input signal pulses and additional pulses would follow spaced 4096 cycles of the input signal frequency apart. In order to cause the first input signal pulse to produce

an output pulse, i.e., "go all the way through," the reset resistor was introduced into the opposite stage of each pair than it would have been normally. This is the condition that would usually exist after 4095 cycles of the input signal frequency. Thus the first pulse started a count and 4096 cycles later the count was stopped by the next pulse.

In order to determine the overall accuracy of the counting equipment, a Hewlett Packard low frequency standard of 1000 cycles was counted for 8 seconds. The results showed the device to be accurate within the limits of the crystals which is 1 part per million plus 1 cycle of 100 Kc. For data see appendix III.

7. Analoging circuit

For the data collected the precession frequency was counted and the answer indicated on the lighted dials of the H.P. 524A counter. For some applications, it would be preferable to have the result of the successive measurements continuously recorded on a tape recording voltmeter such as the Esterline-Angus or Brown. It is possible to accomplish this by using another binary counting circuit that will count to 64. To this circuit can be fed the same 100 Kc frequency that is counted by the H.P. 524A when the gate is opened by the 2 Kc signal. The total number of 100 Kc cycles occurring during a 2 second count will be about 200000 and the actual number of cycles will differ from this slightly depending on the exact frequency of precession. When these cycles are fed into the binary counter capable of counting to 64, it will count thru its full range a large number of times and when the 100 Kc is gated off will stop counting. The count indicated at this time on the binary will determine some reference number. If the next count then leaves a different remainder on the

binary indicator lights, this will correspond to a change of field. A change of one cycle of the 100 Kc will cause a change of one count in the binary indicator which corresponds to a change of very nearly $\frac{1}{4}$ in the earth's field. If, in the plate circuit of one of each pair of stages in the binary circuit is placed a relay switch that switches in a voltage of a certain amplitude then the 100 Kc frequency count can be converted to a voltage amplitude. The weight given to the six stages of this binary counter are 1, 2, 4, 8, 16, and 32 so that the voltages switched in by the various pairs of stages should be proportional to these numbers. The total voltage or some fraction thereof can then be applied to a recording voltmeter.

Such a circuit was built and tested with a synthetic signal but time did not permit its incorporation into the overall system.

CHAPTER V

EXPERIMENTAL RESULTS

Data were collected for a plot of the diurnal change of the earth's magnetic field. In general during the day data were collected for ten minutes out of each hour. (A total of 40 pieces of information was collected in a ten minute period). Data were collected continuously for certain periods of the day in order to establish short term trends. A plot of the data is given in figure 24. The tabulated data is appendix IV. Several things of interest are: the polarizing and receiving coils were placed approximately 50 feet from the main laboratory building in order to reduce interference. However, some interference still existed but was less at night when the laboratory was quiet. Also, the effect of the sun is less at night. The data collected starting at 2331 shows a period of over 7 minutes when the indicated change in the earth's field was only $\pm \frac{1}{4} \gamma$. Data taken starting at 0029 shows a drift in the earth's field of 3γ during a ten minute period with a clear "trend" apparent in the data. This same type of trend is evident at other points in the data. Data collected between 0750 and 0820 is believed to have superimposed on the normal change an effect due to the arrival on the Varian parking lot of about 200 automobiles during this period. Data were collected continuously and a total change of 7γ was noted during this time. It is also noted in the data that at the end of the 24 hour cycle the readings indicated a return to the starting point of the previous day.

An additional piece of information on equipment sensitivity was obtained by moving a 3 foot length iron pipe 5 inches in diameter from a point 50 feet distant from the polarizing and receiving coils to within 15 feet. An immediate shift of over 12γ was noted in the data. (See appendix V).

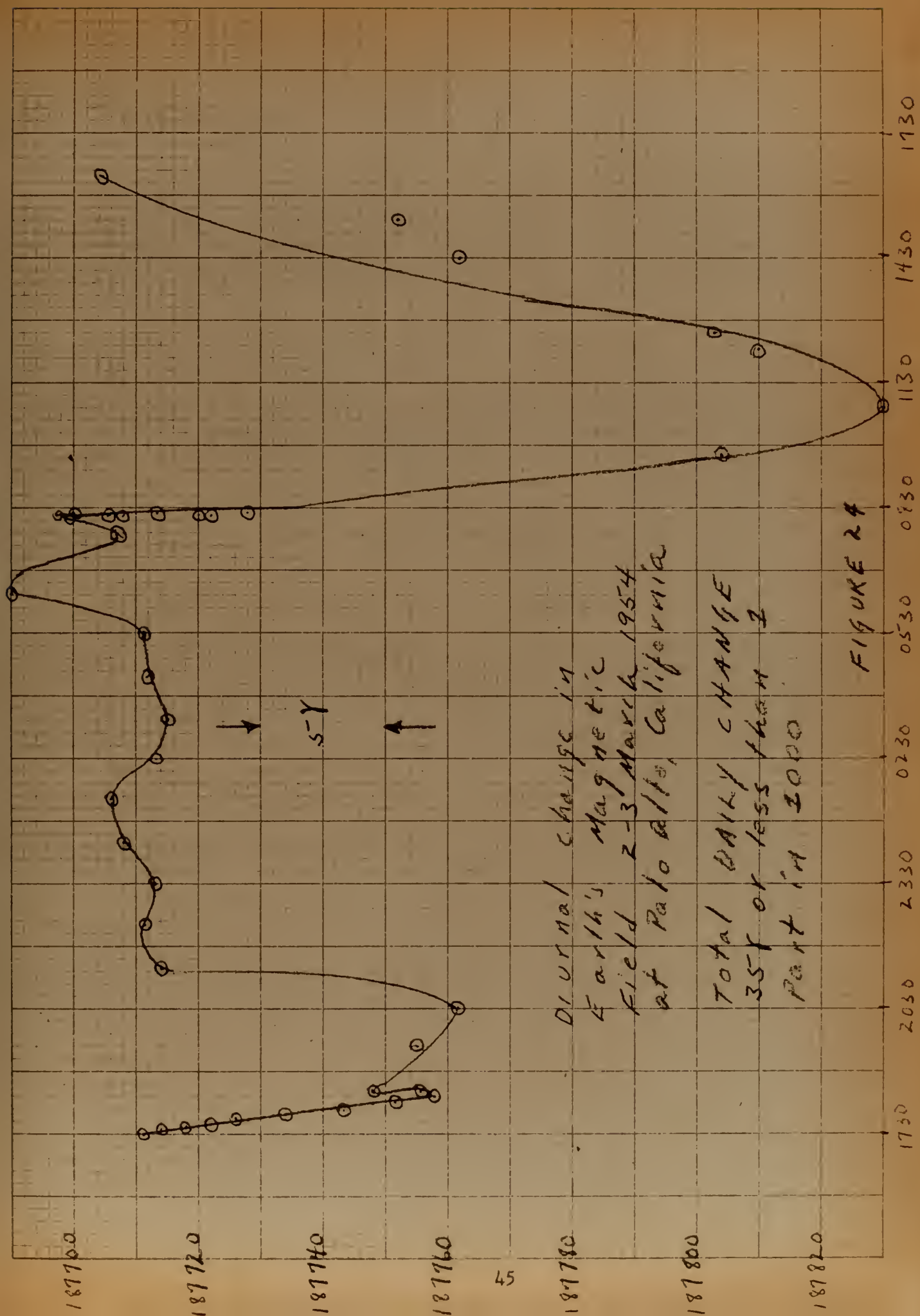

Diurnal change in
 Earth's Magnetic
 Field 2-3 March 1954
 at Palo Alto, California

Total Daily Change
 35γ or less than 1
 part in 1000

FIGURE 24

CHAPTER VI

CONCLUSIONS

1. Possible Errors:

It is believed that changes in the earth's field of $\frac{1}{4} \gamma$ can be detected, with the present equipment configuration. The limitation is imposed by the fact that the count is for only 2 seconds and the base counting frequency is 100 Kc. If this base frequency were increased to 500 Kc then changes of $1/20 \gamma$ should be detectable. Accuracy of course is also dependent on the stability of the oscillator creating the base frequency but with crystal controlled oscillators errors from this source should be less than one part per million. Noise is another possible source of error but with initial S/N ratios of 20 or 30/1, this is not a problem unless long counts are attempted.

Accuracy with $\frac{1}{2} \gamma$ for measurement of the absolute value of the earth's field was achieved. Greater accuracy than this is not claimed since the gyromagnetic ratio as measured by the Bureau of Standards was only accurate to within one part in 40000. Also the exact way in which the squared up signal wave crosses the axis affects the accuracy of the count slightly.

2. General Comments and Applications

The accuracy of the system which has been described depends solely on the accuracy of measurement of the frequency of precession. The orientation of the coils need not be exact and the precession frequency is not affected by temperature or humidity changes. Further, the equipment does not operate as a rate of change instrument and does not require motion.

The equipment exclusive of the frequency counting devices could be reduced to a 25 pound package--something that could be carried by one man.

The 2 Kc signal could be telemetered to a remote spot where its exact frequency could be determined.

This system would obviously have applications as a station magnetometer for a magnetic observatory. It could also be used for magnetic prospecting either as an airborne or ground equipment. Possible military applications in harbor defense and anti-submarine warfare are also evident.

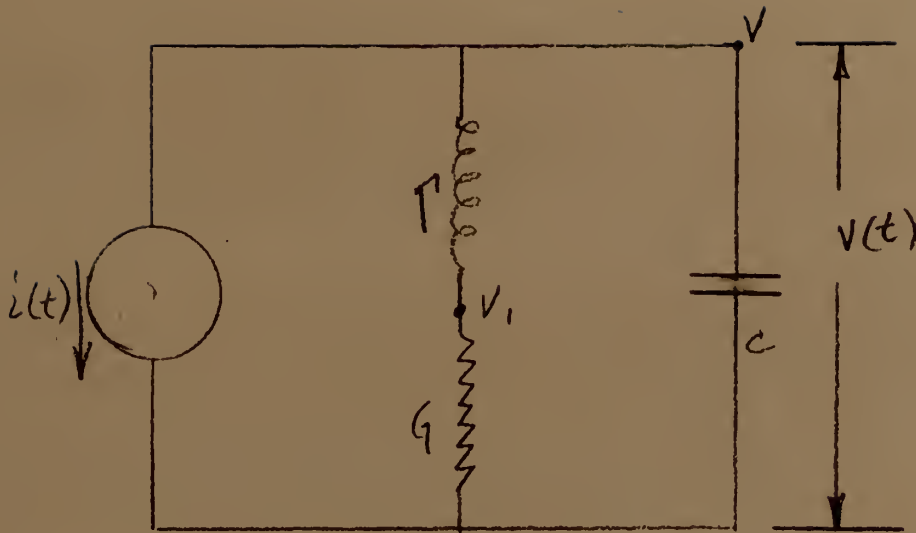

ON MODAL BASIS

$$\left(Cs + \frac{r}{s} \right) v - \left(\frac{r}{s} \right) v_1 = -I(s)$$

$$-\frac{r}{s} v + \left(G + \frac{r}{s} \right) v_1 = 0$$

$$I(t) = I e^{-\alpha t} \sin \beta t$$

$$I(s) = \frac{I \beta}{(\alpha + s)^2 + \beta^2}$$

$$V = \frac{-I(s) \left(G + \frac{\pi}{s} \right)}{G C s + C \pi + G \frac{\pi}{s} + \left(\frac{\pi}{s} \right)^2 - \left(\frac{\pi}{s} \right)^2}$$

$$= -I(s) \frac{(sG + \pi)}{C G s^2 + C \pi s + G \pi}$$

$$= -I(s) \frac{sG + \frac{\pi}{G}}{s^2 C + \frac{C \pi s}{G} + \pi}$$

$$= -\frac{I(s)}{C} \frac{s + \pi/G}{s^2 + \frac{\pi}{G} s + \frac{\pi}{C}}$$

$$= -\frac{I(s)}{C} \frac{s + \frac{R}{L}}{s^2 + \frac{R}{L} s + \frac{1}{LC}}$$

$$= -I \frac{\beta}{C} \frac{s + \alpha/L}{\left[(s + \alpha)^2 + \beta^2 \right] \left[s^2 + \frac{R}{L} s + \frac{1}{LC} \right]}$$

$$V = -\frac{I\beta}{C} \cdot \frac{s + R/L}{[(s + \alpha)^2 + \beta^2] \left[(s + \frac{R}{2L})^2 + \frac{1}{LC} - (\frac{R}{2L})^2 \right]}$$

$$\text{let } -\frac{I\beta}{C} = Kw \quad \text{since } \beta = \omega$$

$$+ \text{if } (s + \alpha)^2 + \beta^2 = 0$$

$$(s + \alpha)^2 = -\beta^2$$

$$s + \alpha = \pm j\beta$$

$$s = -\alpha + j\beta, \quad -\alpha - j\beta$$

similarly

$$s = -\frac{R}{2L} + j \left(\frac{1}{LC} - (\frac{R}{2L})^2 \right)$$

$$-\frac{R}{2L} - j \left(\frac{1}{LC} - (\frac{R}{2L})^2 \right)$$

$$\text{let } -\frac{R}{2L} = -\delta, \quad \text{then } \frac{R}{L} = 2\delta$$

$$\text{let } \frac{1}{LC} - (\frac{R}{2L})^2 = \gamma^2$$

$$s = -\delta + j\gamma, \quad -\delta - j\gamma$$

$$V(s) = K w \frac{s + 2\delta}{(s + \alpha - j\beta)(s + \alpha + j\beta)(s + \delta + jr)(s + \delta - jr)}$$

$$\frac{V(t)}{K w} = \frac{(-\alpha + j\beta + 2\delta) e^{(-\alpha + j\beta)t}}{2j\beta((-\alpha + j\beta + \delta)^2 + \delta^2)} \quad (1)$$

$$\frac{(-\alpha - j\beta + 2\delta) e^{(-\alpha - j\beta)t}}{-2j\beta((-\alpha - j\beta + \delta)^2 + \delta^2)} \quad (2)$$

$$\frac{(-\delta - jr + 2\delta) e^{(-\delta - jr)t}}{[(-\delta - jr + \alpha)^2 + \beta^2] (-2jr)} \quad (3)$$

$$\frac{(-\delta + jr + 2\delta) e^{(-\delta + jr)t}}{((-\alpha + jr + \alpha)^2 + \beta^2) (2jr)} \quad (4)$$

Terms (1) and (2) are complex conjugates
 " (3) " (4) " " " "

Taking twice the real part of one in each case:

$$\frac{v(t)}{k_w} = \cancel{\lambda} \operatorname{Re} \left[\frac{(-\alpha + 2\delta + j\beta) e^{-\lambda t} e^{j\beta t}}{\cancel{\lambda} j\beta ((-\alpha + \delta + j\beta)^2 + r^2)} \right] \\ + \cancel{\lambda} \operatorname{Re} \left[\frac{(\delta + jr) e^{-\delta t} e^{jr t}}{\cancel{\lambda} jr ((-\delta + \alpha + jr)^2 + \beta^2)} \right]$$

$$\frac{v(t)}{k_w} = \operatorname{Re} \left[\frac{(-\alpha + 2\delta + j\beta) e^{-\lambda t} e^{j\beta t}}{j\beta (-\alpha + \delta + j\beta) (-\alpha + \delta + j\beta) + j\beta r^2} \right] \\ + \operatorname{Re} \left[\frac{(\delta + jr) e^{-\delta t} e^{jr t}}{jr (-\delta + \alpha + jr) (-\delta + \alpha + jr) + j\beta^2} \right]$$

after some further manipulation, the voltage as a function of time is:

$$\frac{V(t)}{KW} = \frac{e^{-\alpha t}}{\beta} \sqrt{\frac{(-\alpha + 2\delta)^2 + \beta^2}{4\beta^2(\alpha - \delta)^2 + (\gamma^2 - \beta^2 + \alpha^2 - 2\delta)^2}} \times \cos(\beta t + \psi_1 - \psi_2)$$

$$+ \frac{e^{-\delta t}}{\gamma} \sqrt{\frac{\delta^2 + \gamma^2}{4\gamma^2(\delta - \alpha)^2 + (\beta^2 - \gamma^2 + \delta^2 - \delta\alpha)^2}} \times \cos(\gamma t + \psi_3 - \psi_4)$$

$$\psi_1 = \arctan \frac{\beta}{-\alpha + 2\delta}$$

$$\psi_2 = \arctan \frac{\beta(\gamma^2 - \beta^2 + \alpha^2 - 2\delta)}{2\beta^2(\alpha - \delta)}$$

$$\psi_3 = \arctan \frac{\gamma}{\delta}$$

$$\psi_4 = \arctan \frac{\gamma(\beta^2 - \gamma^2 + \delta^2 - \delta\alpha)}{2\gamma^2(\delta - \alpha)}$$

+f $\alpha = 1$, $\varphi = 200$ and frequency
= 2000 ν

$$\varphi = \frac{\omega L}{R} = 200$$

$$\frac{L}{R} = \frac{200}{6.28 \times 2000}$$

$$\frac{R}{L} = 62.8$$

$$\frac{R}{2L} = 31.4$$

$$\beta = 6.28 \times 2.00 \\ = 12.56 \times 10^3$$

$$\alpha = 1$$

$$\delta = 31.4$$

$$\psi_1 = \arctan \frac{12.56 \times 10^3}{61.8}$$

$$= \arctan 203$$

$$\psi_1 \approx 0$$

$$\psi_2 = \arctan \frac{12.56 \times 10^3 (1.58 \times 10^8 - 1.58 \times 10^6 + 1 - 31.4)}{2 \times 158 \times 10^6 (30.4)}$$
$$= \arctan \frac{1.345}{1000}$$

$$\psi_2 \approx 90^\circ$$

so, for 1st term

$$\frac{-e^{-t}}{12.56 \times 10^3} \sqrt{\frac{3820 + 12560}{4 \times 12560(923) + 1.058 \times 10^6}}$$
$$\times \sin(2\pi 2000)t$$

which reduces to

$$-e^{-t} 1.485 \times 10^{-6} \sin 12.56 \times 10^3 t$$

The second term

$$\frac{e^{-\delta t}}{r} \sqrt{\frac{\delta^2 + r^2}{4r^2(\delta - \alpha)^2 + (\beta^2 - r^2 + \delta^2 - \delta\alpha)^2}}$$
$$\cos(rt + \psi_3 - \psi_4)$$

$$\psi_3 = \arctan \frac{12.56 \times 10^3 - 31.4}{31.4}$$

$$\psi_3 \approx 0$$

$$\psi_4 = \arctan \frac{998 + 988 - 31.4}{12.56 \times 10^3 \times 60.8}$$

$$\psi_4 \approx 90^\circ$$

second term

$$\frac{e^{-31.4t}}{12.56 \times 10^3} \sqrt{\frac{988 + 158 \times 10^6}{4 \times 158 \times 10^6 (925) + (988 + 988 - 314)^2}}$$

which reduces to

$$\frac{e^{-31.4t}}{12.56} 16.5 \sin \gamma t$$

$$\gamma^2 = \frac{1}{LC} - \left(\frac{R}{2L}\right)^2$$

$$\gamma \approx \omega$$

$$\frac{V(t)}{k\omega} = (1.485 e^{-t} - 1.316 e^{-31.4t}) \times 10^{-6} \times \sin \omega t$$

now, if t assumes various values the envelope of the wave form obtained

is:

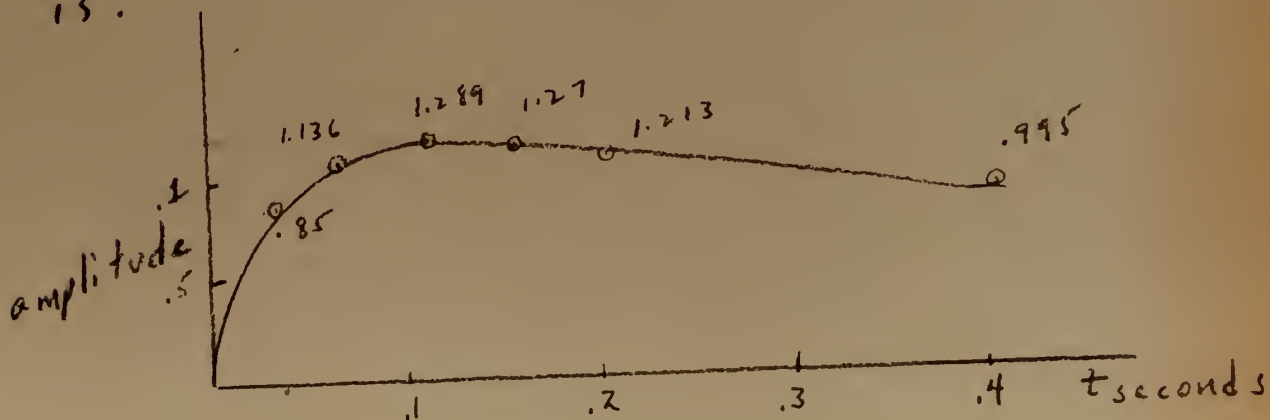

APPENDIX II

The accuracy is changing at a rate $k(e^{-\lambda t} - \lambda t)$. This is a derivative. It is the rate of change of accuracy with respect to time. To maximize set equal to zero.

$$k(e^{-\lambda t} - \lambda t) = 0$$

which is a maximum when
 $t = .567$

or graphically

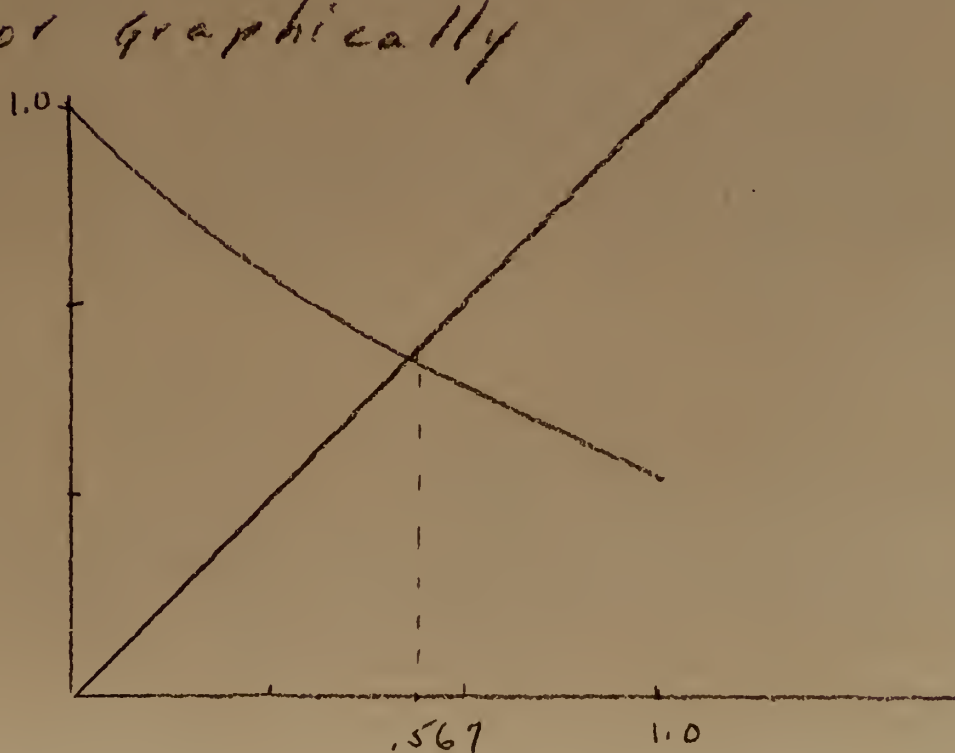

APPENDIX III

1	819208
2	819208
3	819208
4	819208
5	819208
6	819209
7	819209
8	819209
9	819209
10	819208
11	819208
12	819208
13	819209
14	819209
15	819209
16	819208
17	819208
18	819209
19	819209
20	819209

APPENDIX IV

SUMMARY OF DATA TAKEN 2, 3 MARCH

1728-38	187710.6
1820-28	187747.8
1933-43	187754.8
2030-38	187761.7
2129-39	187713.9
2229-39	187711.1
2331-41	187712.3
0029-39	187708.8
0123-33	187705.2
0215-25	187712.4
0315-25	187715.4
0415-25	187711.3
0515-25	187701.6
0615-25	187689.2
0715-25	187707.1
0952-02	187802.1
1052-02	187830.0
1208-18	187809.0
1243-53	187802.4
1431-41	187761.3
1532-42	187751.2
1632-42	187704.1

1728

1	187,705
2	09
3	07
4	09
5	08
6	11
7	10
8	10
9	14
10	11
11	11
12	14
13	13
14	09
15	10
16	11
17	13
18	12
19	14
20	11

1732

1	187710
2	12
3	13
4	12
5	11
6	12
7	14
8	12
9	14
10	12
11	14
12	16
13	15
14	14
15	16
16	14
17	16
18	14
19	16
20	16

1738

1	187714
2	17
3	19
4	14
5	16
6	20
7	19
8	16
9	16
10	17
11	20
12	18
13	17
14	18
15	17
16	20
17	19
18	18
19	17
20	18

1743

1	187717
2	18
3	20
4	17
5	20
6	21
7	21
8	21
9	21
10	23
11	22
12	22
13	24
14	22
15	22
16	25
17	26
18	27
19	23
20	29

1748.5

1	187728
2	28
3	32
4	28
5	27
6	30
7	30
8	28
9	29
10	28
11	30
12	30
13	29
14	27
15	30
16	30
17	32
18	33
19	33
20	31

1753.5

1	187731
2	31
3	34
4	32
5	35
6	37
7	33
8	31
9	34
10	34
11	32
12	32
13	35
14	36
15	35
16	32
17	34
18	34
19	34
20	35

1759

1	187734
2	35
3	38
4	36
5	38
6	44
7	42
8	44
9	41
10	44
11	44
12	47
13	44
14	49
15	49
16	43
17	44
18	48
19	47
20	47

1804

1	187746
2	50
3	51
4	49
5	49
6	49
7	51
8	50
9	50
10	53
11	50
12	55
13	52
14	54
15	55
16	55
17	53
18	57
19	56
20	56

<u>1808</u>		<u>1814</u>	
1	187754	1	187764
2	56	2	61
3	55	3	59
4	57	4	59
5	57	5	59
6	60	6	58
7	60	7	59
8	62	8	59
9	58	9	61
10	59	10	59
11	60	11	58
12	57	12	59
13	63	13	60
14	58	14	57
15	59	15	56
16	59	16	58
17	62	17	57
18	61	18	55
19	59	19	56
20	59	20	54

1820

1	187754
2	53
3	52
4	50
5	53
6	50
7	49
8	50
9	47
10	46
11	47
12	46
13	51
14	45
15	45
16	45
17	46
18	42
19	44
20	42

1933

1	187753
2	53
3	54
4	54
5	57
6	55
7	56
8	55
9	55
10	56
11	56
12	56
13	55
14	54
15	55
16	55
17	54
18	55
19	54
20	55

2030

1	187709	21	1876	86
2	09	22		85
3	05	23		85
4	04	24		85
5	04	25		87
6	03	26		87
7	02	27		88
8	01	28		87
9	01	29		86
10	1876 97	30		85
11	96	31		86
12	96	32		87
13	91	33		87
14	92	34		87
15	90	35		84
16	87	36		85
17	92	37		85
18	87	38		88
19	90	39		87
20	85	40		86

1	1877	13	21	13
2		13	22	14
3		12	23	14
4		12	24	14
5		12	25	14
6		12	26	14
7		14	27	14
8		12	28	15
9		11	29	15
10		11	30	15
11		11	31	16
12		11	32	16
13		11	33	17
14		13	34	17
15		11	35	17
16		12	36	18
17		15	37	17
18		13	38	17
19		12	39	17
20		13	40	18

2229

1	187712	21	187710
2	13	22	10
3	13	23	11
4	12	24	11
5	10	25	10
6	12	26	10
7	11	27	10
8	11	28	10
9	12	29	11
10	12	30	11
11	12	31	11
12	12	32	12
13	11	33	11
14	12	34	11
15	11	35	11
16	12	36	10
17	11	37	11
18	11	38	10
19	11	39	10
20	11	40	10

2331

1	187713	21	187711
2	14	22	3
3	12	23	3
4	12	24	3
5	12	25	2
6	13	26	2
7	12	27	3
8	12	28	2
9	12	29	2
10	12	30	2
11	13	31	2
12	12	32	2
13	12	33	3
14	12	34	2
15	12	35	2
16	12	36	3
17	13	37	2
18	13	38	2
19	12	39	3
20	11	40	2

0029

1	187703	21	187711
2	04	22	11
3	04	23	11
4	05	24	13
5	05	25	13
6	05	26	14
7	05	27	14
8	05	28	14
9	06	29	15
10	06	30	13
11	07	31	15
12	07	32	15
13	08	33	15
14	09	34	14
15	09	35	15
16	09	36	15
17	10	37	15
18	10	38	16
19	09	39	15
20	11	40	14

0123

1	187707	21	6
2	8	22	4
3	7	23	6
4	7	24	6
5	7	25	5
6	7	26	5
7	7	27	3
8	7	28	2
9	7	29	4
10	7	30	2
11	6	31	3
12	7	32	3
13	7	33	2
14	6	34	3
15	7	35	2
16	6	36	2
17	7	37	3
18	7	38	3
19	7	39	4
20	7	40	4

0215

1	187713	21	187711
2	3	22	2
3	2	23	2
4	3	24	2
5	2	25	1
6	2	26	2
7	2	27	2
8	2	28	2
9	5	29	2
10	2	30	1
11	2	31	3
12	2	32	3
13	3	33	3
14	2	34	3
15	2	35	3
16	1	36	4
17	2	37	4
18	1	38	4
19	1	39	4
20	2	40	5

0315

1	187714	21	187711
2	21	22	14
3	15	23	19
4	23	24	18
5	26	25	17
6	19	26	19
7	17	27	20
8	09	28	17
9	16	29	19
10	09	30	14
11	17	31	09
12	18	32	13
13	19	33	13
14	13	34	11
15	12	35	12
16	17	36	11
17	24	37	11
18	19	38	11
19	20	39	11
20	10	40	11

1	187710	21	187710
2	11	22	11
3	10	23	12
4	09	24	12
5	09	25	12
6	10	26	12
7	10	27	12
8	10	28	11
9	10	29	11
10	09	30	12
11	09	31	13
12	10	32	13
13	09	33	13
14	10	34	15
15	10	35	15
16	10	36	14
17	10	37	14
18	10	38	14
19	11	39	14
20	09	40	16

0515

1	187713	21	187687
2	10	22	87
3	09	23	97
4	08	24	98
5	07	25	98
6	07	26	99
7	06	27	99
8	06	28	700
9	05	29	700
10	07	30	699
11	06	31	700
12	04	32	700
13	02	33	701
14	02	34	700
15	03	35	700
16	01	36	701
17	01	37	702
18	00	38	701
19	00	39	701
20	697	40	702

0615

1	187691	21	187687
2	91	22	86
3	92	23	84
4	93	24	86
5	94	25	88
6	94	26	89
7	93	27	88
8	92	28	88
9	91	29	89
10	91	30	89
11	90	31	88
12	89	32	90
13	89	33	90
14	85	34	91
15	86	35	91
16	86	36	91
17	84	37	92
18	86	38	91
19	87	39	92
20	87	40	91

0713

1	187708
2	6
3	7
4	8
5	6
6	5
7	7
8	7
9	9
10	8

0748

1	187699	21	695
2	97	22	695
3	99	23	696
4	700	24	697
5	699	25	695
6	699	26	696
7	697	27	696
8	698	28	697
9	699	29	694
10	698	30	697
11	699	31	697
12	700	32	698
13	699		
14	698		
15	697		
16	697		
17	697		
18	696		
19	696		
20	696		

1	187699	(0800)	25	703	54	718
2	698		26	706	55	718
3	698		27			
4	699		28	705 (0807.5)		
5	702		29	707		
6	702		30	705		
7	699	(0802)	31	703		
8	700		32	705		
9	700		33	704		
10	698		34	708		
11	699		35	708 (0809.5)		
12	700		36	707		
13	699		37	711		
14	700		38	709		
15	701		39	708		
16	700		40	706		
17	701	(0805)	41	707		
18	701		42	710		
19	702		43	710		
20	702		44	712		
21	704		45	714		
22	705		46	715		
23	703		47	717		
24	705		48	717 (0814)		
			49	719		
			50	718		
			51	718		
			52	718		
			53	719		

0952

1	187797	21	187803
2	98	22	803
3	98	23	803
4	98	24	803
5	97	25	805
6	98	26	804
7	96	27	803
8	97	28	803
9	98	29	810
10	802		
11	801		
12	803		
13	801		
14	802		
15	800		
16	802		
17	801		
18	800		
19	800		
20	803		

1052

1	187831	21	187831
2	2	22	32
3	3	23	37
4	3	24	30
5	2	25	27
6	4	26	26
7	4	27	28
8	5	28	29
9	3	29	28
10	4	30	27
11	5	31	28
12	4	32	29
13	3	33	29
14	3	34	28
15	4	35	33
16	1	36	32
17	3	37	32
18	2	38	32
19	3	39	33
20	2	40	

1208

1	187808	21	187811
2	08	22	11
3	09	23	11
4	08	24	11
5	08	25	10
6	08	26	10
7	07	27	10
8	07	28	09
9	06	29	09
10	05	30	09
11	06	31	09
12	07	32	10
13	07	33	09
14	07	34	09
15	08	35	10
16	09	36	11
17	11	37	10
18	10	38	16
19	10	39	11
20	11	40	12

1243

<u>1243</u>					<u>1253</u>	
1	187806	21	187803			
2	04	22	01	41	800	
3	06	23	07	42	801	
4	06	24	01	43	799	
5	06	25	00	44	800	
6	06	26	00	45	800	
7	05	27	02	46	800	
8	04	28	00	47	802	
9	02	29	02	48	802	
10	02	30	02	49	801	
11	03	31	01	50	801	
12	03	32	01	51		
13	03	33	01			
14	02	34	01			
15	03	35	01			
16	01	36	01			
17	03	37	01			
18	02	38	01			
19	02	39	00			
20	02	40	01			

1431

1	187768	21	187762
2	67	22	63
3	67	23	65
4	66	24	61
5	64	25	61
6	69	26	62
7	62	27	59
8	187762	28	59
9	62	29	58
10	60	30	59
11	61	31	58
12	61	32	59
13	62	33	58
14	62	34	59
15	62	35	58
16	62	36	58
17	61	37	58
18	61	38	58
19	62	39	57
20	62	40	57

1532

1	187752	21	187754
2	52	22	1
3	4	23	2
4	1	24	3
5	2	25	2
6	1	26	2
7	1	27	0
8	0	28	0
9	2	29	3
10	0	30	1
11	4	31	51
12	4	32	47
13	3	33	51
14	3	34	48
15	2	35	47
16	3	36	47
17	1	37	50
18	5	38	49
19	3	39	48
20	4	40	48

1	18712	21	187699
2	12	22	701
3	12	23	702
4	12	24	701
5	09	25	701
6	08	26	701
7	09	27	701
8	06	28	701
9	07	29	702
10	10	30	699
11	710	31	702
12	711	32	700
13	710	33	700
14	708	34	698
15	707	35	699
16	707	36	700
17	707	37	698
18	707	38	699
19	707	39	698
20	696	40	699

APPENDIX V

Pipe at 50 '

- 1 187576
- 2 187575
- 3 187578
- 4 187579
- 5 187576
- 6 187577
- 7 187574
- 8 187578
- 9 187579
- 10 187581

Pipe moved to 15 '

- 11 187521
- 12 187524
- 13 187521
- 14 187520
- 15 187522
- 16 187522
- 17 187523
- 18 187522
- 19 187525
- 20 187525

BIBLIOGRAPHY

1. Bloch, F. Physical Review 70 460 (1946)
2. Bloch, F. Hansen, W.W. and Packard, M. Physical Review 20 474 (1946)
3. Electronics May 1951 Simplified Q Multiplier P 130
4. Levinthal and Rodgers Measurements of low magnetic fields using paramagnetic resonance Report prepared for University of California Rad lab P.O. #H-24656 April 6, 1951
5. McComb, Magnetic Observatory Manual U.S. Department of Commerce Special Publication 283 1952
6. NOL Laboratory Report 937 1945
7. Packard, Dr. Martin Method of nuclear induction thesis Stanford
8. Purcell, E.M. Torey, J.C., Pound, R.V. Physical Review 69, 37 1946
9. Wyckoff, R.D. The gulf airborne magnetometer Geophysics volume 13 pp48-56 1936

8 MAR 73
1 NOV 75

21610
23554

Thesis
.B74

25283

Bowen
An Earth's field
magnetometer that utilizes
the free precession of
protons.

8 MAR 73
1 NOV 75

21610
23554

25283

Thesis
B74

Bowen
An Earth's field magnetometer
that utilizes the free precession
of protons.

thesB74

An Earth's field magnetometer that utili

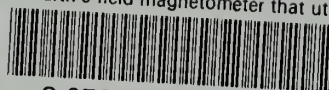

3 2768 002 07364 5

DUDLEY KNOX LIBRARY