

UNCLASSIFIED

AD NUMBER

AD483670

LIMITATION CHANGES

TO:

Approved for public release; distribution is unlimited.

FROM:

Distribution authorized to U.S. Gov't. agencies and their contractors;  
Administrative/Operational Use; MAY 1966. Other requests shall be referred to Naval Postgraduate School, Monterey, CA.

AUTHORITY

NPS ltr 28 Jun 1971

THIS PAGE IS UNCLASSIFIED

483670

UNITED STATES  
NAVAL POSTGRADUATE SCHOOL



THESIS

RADIOACTIVE GASEOUS EFFLUENTS FROM  
THE CORE OF THE AGR-201 REACTOR  
AT THE UNITED STATES NAVAL POSTGRADUATE SCHOOL

by

Rudolf Theodore Andrew Bredderman

May 1966

This document is subject to special export controls and each transmittal to foreign government or foreign nationals may be made only with prior approval of the U. S. Naval Postgraduate School.

RADIOACTIVE GASEOUS EFFLUENTS FROM THE CORE OF THE AGN-201  
REACTOR AT THE UNITED STATES NAVAL POSTGRADUATE SCHOOL

by

Rudolf Theodore Andrew Bredderman  
Lieutenant Commander, United States Navy  
B.S., Cornell University, 1956

Submitted in partial fulfillment  
for the degree of

MASTER OF SCIENCE IN PHYSICS

from the

UNITED STATES NAVAL POSTGRADUATE SCHOOL

May 1966

Signature of Author *Rudolf TA Bredderman*  
Nuclear Engr (Effects) Curriculum, May, 1966

Certified by *John D. Ripp*  
Thesis Advisor

Accepted by *E. L. Britten*  
Chairman, Department of Physics

Approved by *R. F. Rinchart*  
Academic Dean

#### ABSTRACT

A qualitative and quantitative analysis of the core gas generated by the AGN-201 reactor at the United States Naval Postgraduate School was made by analysis of the spectrum of gamma-rays emitted two hours after peak power operations. The principle radioactive isotopes present, based on gamma-ray photopeak energies and half-lives, were found to be  $\text{Kr}^{84m}$ ,  $\text{Kr}^{87}$ ,  $\text{Kr}^{88}$ ,  $\text{Xe}^{133}$ , and  $\text{Xe}^{135}$ . The total activity (gamma-ray energies  $\leq 2.7$  Mev) was found to be  $363 \pm 4$  microcuries per milliliter. The percent of the total activity due to the presence of each isotope identified in the order stated above is 10.2%, 9.0%, 47.4%, 18.6%, and 4.4%. The sources of the remaining 10.4% of the total activity were not identified.

## TABLE OF CONTENTS

Section	Page
1. Introduction	11
2. Equipment	
a. Scintillation detector, enclosure and preamplifier	11
b. Power supplies	12
c. Multi-Channel Pulse Height Analyzer	12
d. Gas sample bottles	13
3. Equipment Calibration	
a. Gas bottle volume	13
b. Counting efficiency	17
c. Channel vs. Energy relationship for Multi-Channel Analyzer	18
d. Peak-to-Total Ratio	18
4. Procedures	
a. Gas sampling	19
b. Obtaining gamma-ray spectrum	20
c. Determination of half-lives	21
d. Activity determination	21
5. Results	
a. Qualitative results	23
b. Quantitative results	30
6. Conclusions	33
7. Acknowledgements	34
8. Bibliography	36
APPENDIX I Comparisons of the Original Gamma-ray Spectrum with Spectrums Four and Fourteen Hours Later	37
APPENDIX II Decay Curves for Observed Photopeaks	39
APPENDIX III Gamma-ray Spectrum Assigned to Each Identified Isotope	48
APPENDIX IV Energy vs. Channel Number Curve for 14 March 1966	54

LIST OF TABLES

Table	Page
I. Photopeak Energies and Half-lives	25
IIa. Decay of Parent Isotopes	26
IIb. Decay Scheme of Identified Isotopes	27
III. Gamma-rays Emitted by Radioactive Nuclei	29
IV. Activity Associated with Each Photopeak	31
V. Activity Associated with Each Identified Radioactive Isotope	32

Previous pages were blank, therefore not filmed.

LIST OF ILLUSTRATIONS

Figure		Page
1.	Block Diagram of Scintillation Detector and Pulse Height Analyzer	14
2.	Diagram of Sample Bottle and Photomultiplier Tube with NaI(Tl) Crystal	15
3.	Block Diagram of Reactor Gas Handling System	16

Opacous pages were blank, therefore not filmed.

## TABLE OF SYMBOLS AND ABBREVIATIONS

### Symbols

$a$	Activity
D	Disintegration rate
$\phi$	Thermal Neutron Flux
$\sigma_t$	Thermal cross-section
W	Weight of foil
No	Avogadro's number
Aw	Atomic weight
$\lambda$	Disintegration constant
$t_a$	Activation time
t	Time
E	Efficiency
Aop	Activity within photopeak at time sample was taken
Np	Number of disintegrations counted within a photopeak
Pp	Peak-to-Total Ratio
V	Volume
$s^2$	Sample variance
s	Standard deviation

### Abbreviations

CDC 1604	Control Data Corporation Computer model 1604
MeV	$10^6$ electron volts
STP	Standard Temperature (0° Centigrade) and Pressure (1 atmosphere)
Au	Gold
Co	Cobalt
Cs	Cesium
Hg	Mercury

Previous pages were blank, therefore not filmed.



Abbreviations

I	Iodine
K	Krypton
Xe	Xenon
Zn	Zinc

## 1. Introduction

Gas is generated in the rods and core of the AGN-201 reactor at the United States Naval Postgraduate School during operation of the reactor. After reactor shut-down, the quantity of the gas builds up from the fission products. The gas increases the internal pressure in the reactor core and must be removed periodically so that the gas pressure in the core and rods does not exceed 5 psig. [1] This is normally done when the reactor has been shut down for approximately two days, at which time the gas still contains radioactive elements. To know what these elements might be, this study was undertaken to determine the identity and concentration of the radioactive elements in the reactor gas approximately two hours after peak power operations. The study was made by obtaining from the reactor core via the gas manifold, a measurable quantity of gas in a container suitable for insertion in a well-type scintillation detector. The gamma spectrum was obtained on a 512 channel pulse height analyzer and a qualitative and quantitative analysis was made on the gamma spectrum.

## 2. Equipment

a. Scintillation detector, enclosure, and preamplifier  
A NaI(Tl) crystal, 3" in diameter by 3" high, with a well 0.781" in diameter by 2.0" high was used. The crystal was an integral part of a Harshaw Type 12SW12-W3 scintillation detector. In assembly, the crystal was directly attached to the photomultiplier tube and both completely encased in .032" thick aluminum. [3]  
The scintillation detector assembly was connected to a

cathode-follower type preamplifier. The signal from the preamplifier was fed directly to the internal amplifier of a 512 channel pulse height analyzer. The scintillation detector and preamplifier were mounted within a 22" by 22" by 28" box enclosures of lead brick lined inside by copper and cadmium plates. A 4" by 6" access port and plug permitted the exchange of active sample containers.

b. Power Supplies

The high voltage for the photomultiplier tube was furnished by a Hamner Model N401 High Voltage Power Supply. The preamplifier power was supplied by a stabilized power supply unit of a Hamner Model N302 Non-overload Linear Amplifier. The amplifier section of this unit was not used.

c. Multi-Channel Pulse Height Analyzer

A Nuclear Data 512 Channel pulse height analyzer Model ND-180 FMR was used. This assembly consisted of an analog-to-digital converter with internal linear amplifier and live-timer, a 512 channel ( $10^6$  capability per channel) parallel binary coded decimal memory system, and a read out control. Associated equipment used with this assembly included an oscilloscope, Teletype printer, and an X-Y plotter. The pertinent specifications quoted by the manufacturer in the instruction manual for this equipment are as follows: [7]

Stability: 0.2% long term stability.

Live Timer Accuracy: Better than 0.5% at pulse rate up to 5000 cpm.

Integral Linearity: Better than 0.25% full scale.

Differential Linearity: Better than 2% over top  
98% of measurement range.

Figure 1 shows the relationship of the above equipment in block diagram form.

d. Gas sample bottles

Gas sample bottles were made of aluminum, each with a volume of about 3.5 ml. The bottles were designed to fit snugly in the well of the scintillation detector and to confine the gas within the bottle as deep as possible in the well. This was done by drilling out from one end a section of aluminum round to form a deep cup, then fitting an aluminum plug within this cup to leave a reservoir for the gas in the bottom of the cup. A small hole was drilled through the center of the plug to permit the filling of the reservoir. The exposed end of the plug was tapped and a valve fitted to this end. The plug was then bonded to the cup and the entire assembly made gas tight. The shape and dimensions of the gas bottles are as indicated in Figure 2 along with the dimensions of the photomultiplier tube and crystal assembly.

3. Equipment Calibration

a. Gas bottle volume. The volume of each gas bottle was determined by filling it with distilled water, recording the weight before and after filling; the difference in weight in grams being the volume in millimeters. The bottles were filled by connecting them to an assembly of valves and tubing, evacuating the entire assembly with a vacuum pump, and then allowing the vacuum to fill the entire assembly with water.

FIGURE 1

BLOCK DIAGRAM OF SCINTILLATION DETECTOR [5]  
and  
PULSE HEIGHT ANALYZER

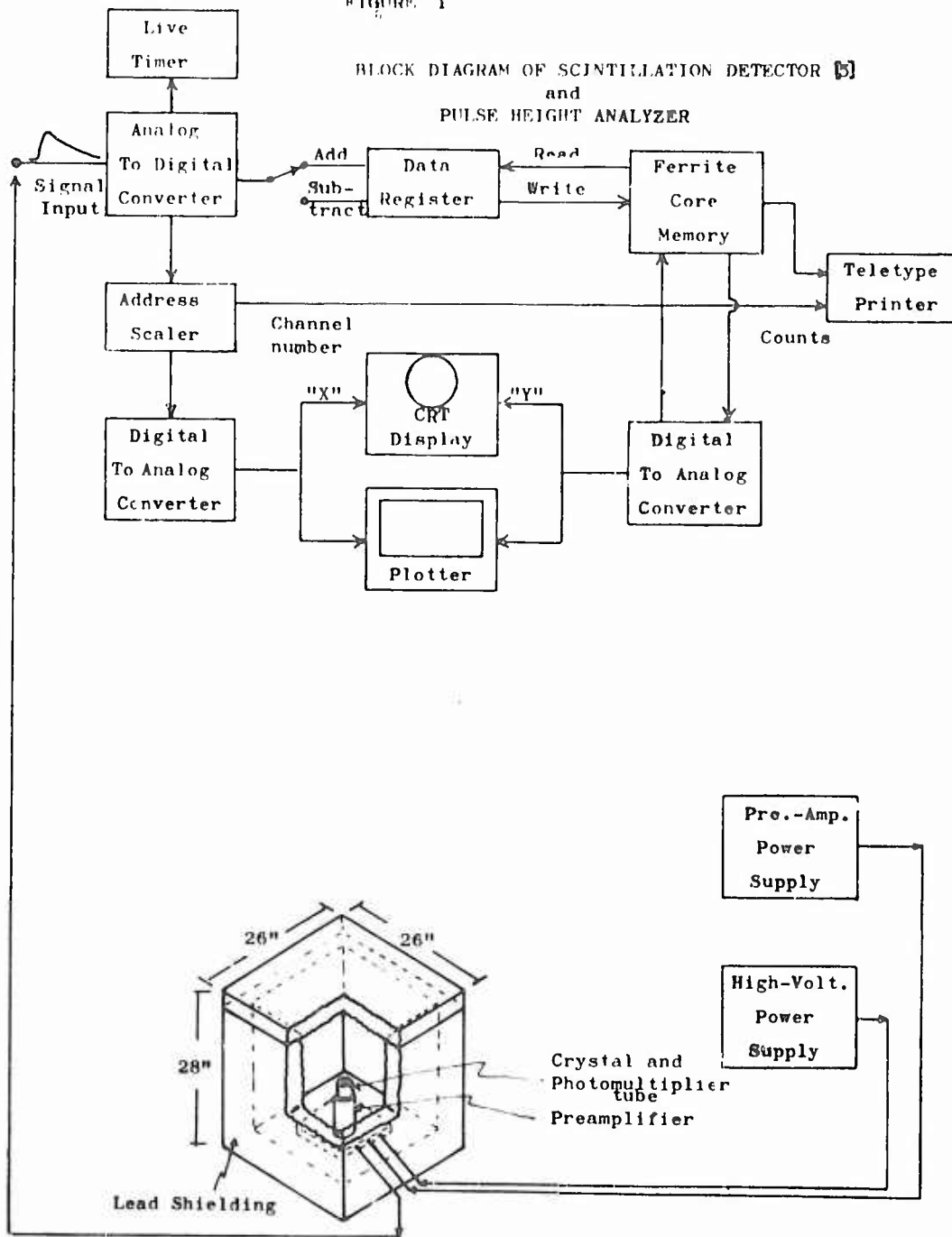
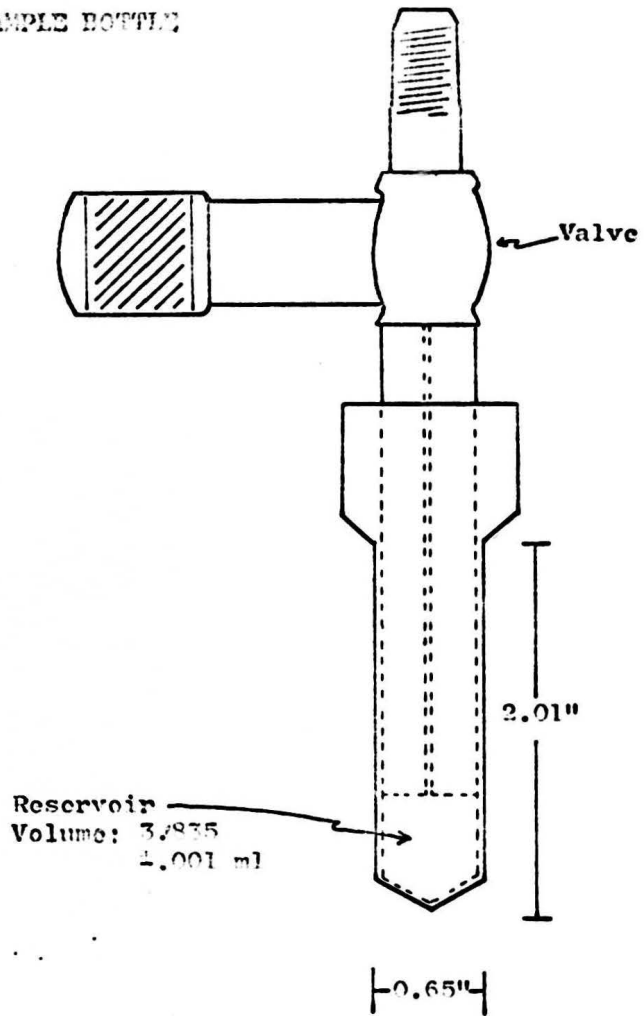
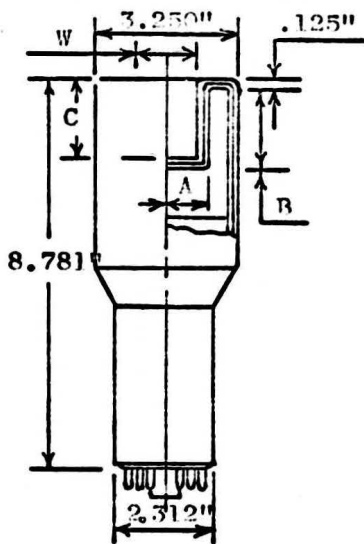

FIGURE 2  
GAS SAMPLE BOTTLE



PHOTOMULTIPLIER TUBE  
with  
NaI(Tl) CRYSTAL [3]



TYPE: 12SW12-W3

DIMENSIONS: (in inches)			
CRYSTAL		WPII	
A	B	C	W
.781	2.000	2.046	.656

Crystal size - 3" dia. x 3" hgt.

FIGURE 3

Block Diagram of Reactor Gas Handling System [1]

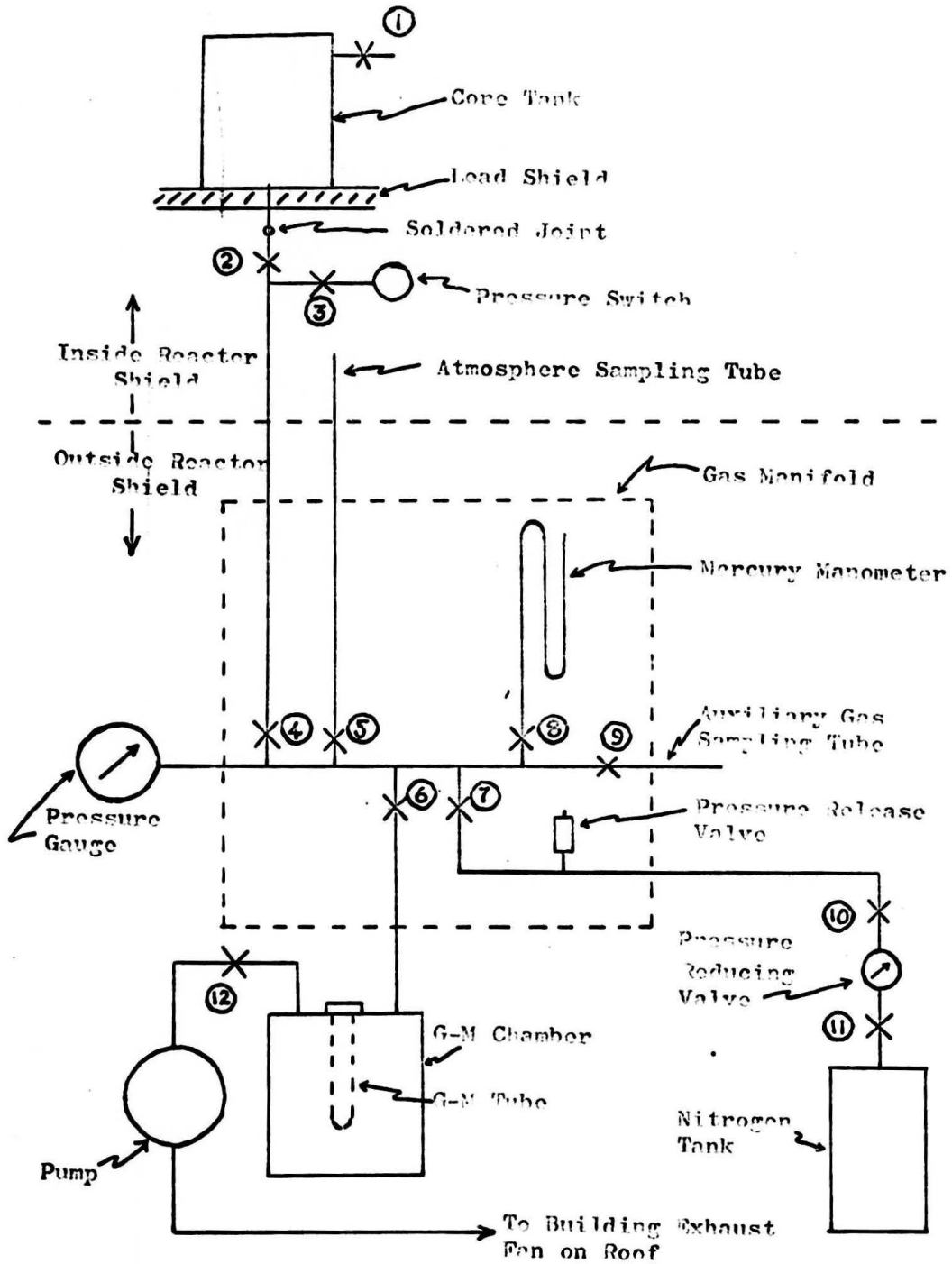

This procedure insured that no air bubbles or pockets were left within the bottles when they were filled with water. The weighing was done on an analytical balance to  $\pm 0.0005$  grams yielding a possible accuracy in volume of  $\pm 0.001$  milliliters. Since there were other uncertainties in determining the volume by this method, it was estimated that the volume was accurate to  $\pm 0.01$  milliliters.

b. Counting efficiency. Two samples of gold foil, each weighing about 30 milligrams were weighed to  $\pm 0.0005$  grams. One was irradiated in the reactor within a cadmium cover for 60 minutes at 20 watts. The second was irradiated in an identical position for the same time at the same power level but without the cadmium cover. The activities of the activated foils were determined using an aluminum sample holder identical in size and shape to the gas bottles but with the plug removable so that the gold foil could be centered within its reservoir. The activity of the cadmium covered foil was subtracted from the activity of the bare foil yielding the activity ( $\alpha$ ) due to the activation of the bare foil by thermal neutrons.

$$\text{From the relationship } D = \frac{\phi \sigma t W N_0 (1 - e^{-\lambda t a})}{A_w} e^{-\lambda t}$$

the disintegration rate ( $D$ ) of the activated gold ( $\text{Au}^{198}$ ) was calculated; where

$\phi$  = thermal neutron flux level of reactor at 20 watts [8]

$\sigma t$  = thermal cross section for  $\text{Au}^{197}$  (8.8 barns)

$W$  = weight of gold foil in grams

$N_0$  = Avogadro's number ( $6.023 \times 10^{23}$  atoms per mole)



- $A_w$  = Atomic weight of gold (197.026 grams per mole)  
 $\lambda$  = disintegration constant for Au<sup>198</sup> ( $1.7848 \times 10^{-4}$  per min.)  
 $t_a$  = activation time  
 $t$  = time lapse between activation and counting

The efficiency ( E ) of the entire counting assembly was then determined from the relationship  $E = \alpha/D$

c. Channel vs. Energy relationship for the multichannel analyzer. Using Cs<sup>137</sup>, I<sup>131</sup>, Zn<sup>65</sup>, Co<sup>60</sup>, and Au<sup>198</sup>; a curve was plotted using the following gamma-ray photopeak energies: 2.50, 1.33, 1.17, 1.114, 0.663, 0.51, 0.411, 0.364, 0.080, 0.069, and 0.032; all in MeV. This was done at periodic times while counting each gas sample. The Channel vs. Energy curve was found to be linear at energies above approximately 0.3 MeV but slightly non-linear below this energy. In addition, the energy associated with a particular channel varied linearly with the gain setting on the internal amplifier.

d. Peak-to-Total ratio. A Peak-to-Total ratio curve paralleling that in Appendix II of Heath [4] was plotted using Au<sup>198</sup>, Cs<sup>137</sup>, and Zn<sup>65</sup> samples counted in the aluminum sample holder. To determine the activity in the photopeak, the counts in the channels within the photopeak were normalized by fitting their natural logarithms to a quadratic by the method of least squares. The total activity was determined by summing the counts in each spectrum up to and including those channels within the photopeak. The activity in photopeaks other than the major photopeak for each sample was subtracted from the total. More points on this curve

were desired but neither active or activatable materials were available.

#### 4. Procedure

a. Gas Sampling. Gas samples were drawn from the reactor gas manifold approximately two hours after peak power operations. This time delay was chosen to permit the build up of the gas in the core and to sample the gas while its components of half-lives of the order of several hours or more were still of sufficient activity to permit analysis.

The gas sampling was done in the following steps:

1. A sample bottle was attached to the Auxiliary Gas Sampling Tube of the manifold.
2. With the valve to the reactor core closed, the bottle, manifold tubing and GM chamber were evacuated to the atmosphere using a vacuum pump until a maximum vacuum was noted on the manometer.
3. Using the vacuum in the GM chamber, new gas was drawn into the manifold by opening the valve to the reactor core; the valve on the gas bottle being closed. The valve to the reactor core was then closed and the gas in the manifold was drawn into the GM chamber. This step was repeated several times until certain the gas in the manifold was new gas from the core and not old gas from the tubing connecting the manifold to the core.
4. The valve to the evacuated gas bottle was then opened and the new gas in the manifold was permitted to fill the gas bottle. The pressure of this gas was adjusted, using the

vacuum in the GM chamber, to a vacuum of about one or two centimeters of Hg. The pressure was recorded and the valve on the gas bottle closed.

5. If more than one sample was to be drawn on the same day, a second bottle was attached to the manifold and steps 3 and 4 above were repeated.

b. Obtaining the Gamma-ray Spectrum. As soon after drawing a sample as was possible, usually about one minute, the bottle was placed in the well of the scintillation detector and a ten minute live-time count was made at the desired gain setting. The multi-channel analyzer permitted the adjustment of gain so that gamma-rays of energies up to about 3 MeV could be counted. It was noted in preliminary runs that there were no significant gamma-ray photopeaks of energies above about 2.7 MeV. It was also noted that after about 24 hours, there was no significant gamma activity above 1.0 MeV and that increasing the gain by a factor of two exactly halved the energy per channel relationship. Therefore counting was done utilizing coarse gain settings of "1" and "2" while the fine gain setting was held at "10.0". Counting at a coarse gain setting of "2" gave better definition to the several photopeaks of energies below 0.40 MeV while counting at a coarse gain setting of "1" permitted the counting of all significant gamma activity in newly obtained samples.

After a count was made, background was removed by putting the analyzer in the "subtract" mode and again counting

for ten minutes live-time, but with no sample in or near the detector. After background was removed, the data in the analyzer memory was printed out and plotted by hand or with the X-Y plotter. (The plots included in the appendixes were made utilizing the CDC 1604 computer.) After the initial count was made, succeeding ten minute counts were made at one hour intervals for about six to twelve hours, then at about six hour intervals for 48 hours and then daily for about two weeks.

c. Determination of half-lives. The half-lives of the component sources of each photopeak were determined in one of two ways.

1. The count in the channel having the maximum count for a particular photopeak was noted, its channel number and corresponding gamma-ray energy obtained. A semi-log plot of counts vs. time was made and graphically analyzed to determine the half-lives of the components.

2. By use of the CDC 1604 computer, the photopeaks of one sample were normalized and the total count within the peak determined. This total count was plotted in the same manner as above. No significant differences were noted in the results obtained by this more involved procedure than by the first procedure.

d. Activity determination. It was noted that the response of the detector to gamma-rays of a particular energy produced a gamma spectrum of a particular shape. That is, in addition to the photopeak, a particular shape was observed

for the rest of the spectrum representing gamma-rays detected after undergoing Compton scattering or back-scattering. A plot of the channel number of the back-scatter peaks vs photopeak energy was made for active samples having a single prominent photopeak. These were Au<sup>198</sup>, Zn<sup>65</sup>, and Cs<sup>137</sup>. Other prominent points in the Compton distribution were similarly plotted. All plots resulted in a straight line relationship except when extrapolated to very low energies. In addition to the spectra of the elements mentioned above, the shape of the Compton distribution between the 1.33 MeV photopeak and the 2.50 sum peak of the spectrum from Co<sup>60</sup> was used to augment the plot from the above three sources. From this plot, the shape of the Compton and backscatter portions of the spectrum for each photopeak observed in gas sample was approximated by interpolation.

Following the procedure in Heath [4], each photopeak, starting with the one from the highest energy gamma-rays, was normalized by fitting the logarithms of the counts in each channel in the photopeak to a quadratic polynomial by the method of least squares. The counts within the normalized photopeak were then summed. Using the peak-to-total ratio, the total counts in the spectrum due to the photopeak being analyzed was determined (Total count = count in photopeak / peak-to-total ratio). The counts in the Compton and backscatter portion of the spectrum were determined by subtracting the counts in the photopeak from the total counts. Having the shape and total count for the Compton and backscatter

portion of the spectrum, a particular count was assigned to each channel within that portion of the spectrum. The entire spectrum thus determined for the photopeak being analyzed was subtracted from the composite spectrum, channel by channel. The next photopeak was then normalized and similar calculations and approximations made for the Compton and backscatter portion of its spectrum.

The total activity at STP was determined for each photopeak and for the entire spectrum utilizing the relationship

$$A_{op} = \frac{N_p}{E P_p t V} \quad \text{where}$$

$N_p$  = count under normalized photopeak

$E$  = detector efficiency ( $0.404 \pm 0.003$ )

$P_p$  = peak-to-total ratio

$t$  = duration of count ( $10.00 \pm .05$  min)

$V$  = volume of gas bottle at STP ( $3.46 \pm 0.01$  ml)

An estimate of the standard deviation of the activity thus determined was made utilizing the relationship

$$s^2 A_{op} = A_{op}^2 \left( \frac{s^2 N_p}{N_p^2} + \frac{s^2 E}{E^2} + \frac{s^2 P_p}{P_p^2} + \frac{s^2 t}{t^2} + \frac{s^2 V}{V^2} \right)$$

5. Results. A total of 13 gas samples were taken on five different days, all from one to three hours after peak power operation (1000 watts). No qualitative difference were observed in the gamma spectra. No significant quantitative difference were observed.

a. Qualitative results. Thirteen significant photopeaks

were observed in the raw spectrum and two more were unmasked in the removal, by channel for channel subtraction, of the more prominent photopeaks and their associated Compton and backscatter spectra. The spectrum obtained on 14 March and spectra of the same sample after four and 14 hours decay have been included for comparison as Appendix I. The measured half-lives of the photopeaks together with the channel number of the center channel in each photopeak and its corresponding energy in MeV are tabulated in Table I. Also included in this table is the identified source for each photopeak, determined on the basis of half-life and photopeak energy using the tables of E. der Mateosien and M. Mc Keown [6]. The findings here are in agreement with those of D. E. Hawkins at Los Alamos who concluded

The radioactive gaseous effluents released from the reactor stack were found to consist of the following noble gases:  $Kr^{85m}$ ,  $Kr^{87}$ ,  $Kr^{88}$ ,  $Xe^{133}$ , and  $Xe^{135}$ . [2]

For each sample, the counts in the photopeaks one and two were observed to increase for approximately 20 hours after the sample was drawn, and to decrease with a half-life consistent with that tabulated for  $Xe^{133}$ . The growth is believed to be due to the decay of the parent isotope  $I^{133}$  with a half-life of 22.4 hours, as is indicated in the decay schemes for the parent isotopes tabulated in Table II. None of the gamma rays associated with the decay of  $I^{133}$  could be found in the spectrum and a 20 hour half-life was not observed anywhere except in the growth of photopeaks one and two. Decay curves for each

TABLE I

## Photopeak Energies and Half-lives

Photopeak	Center Channel	Energy	Half-life	Source
1	6	$0.030 \pm 0.002$	Growth $21 \pm 2$ hrs	Xe <sup>133</sup>
2	15	$0.081 \pm 0.001$	Decay $127 \pm 4$ hrs	Xe <sup>133</sup>
3	30	$0.148 \pm 0.002$	$4.5 \pm 0.2$ hrs	Kr <sup>85m</sup>
4	39	$0.190 \pm 0.002$	$3.0 \pm 0.3$ hrs	Kr <sup>85</sup>
5	51-48	$0.249 \pm 0.002$	$9.1 \pm 0.5$ hrs $60 \pm 4$ hrs	Xe <sup>133</sup> Xe <sup>133m</sup>
6	62	$0.300 \pm 0.005$	$4.2 \pm 0.2$ hrs	Kr <sup>85m</sup>
7	82	$0.400 \pm 0.005$	$1.2 \pm 0.2$ hrs $4.5 \pm 0.2$ hrs	Kr <sup>87</sup>
8	124	$0.610 \pm 0.010$	Undetermined	Xe <sup>135</sup>
9	170	$0.86 \pm 0.015$	$2.7 \pm 0.15$ hrs	Kr <sup>88</sup>
10	238	$1.22 \pm 0.02$	$2.7 \pm 0.2$ hrs	Unknown
11	270	$1.40 \pm 0.02$	$2.8 \pm 0.2$ hrs	Unknown
12	298	$1.55 \pm 0.02$	$2.70 \pm 0.15$ hrs	Kr <sup>88</sup>
13	359	$1.87 \pm 0.02$	$2.7 \pm 0.2$ hrs	Unknown
14	420	$2.20 \pm 0.02$	Undetermined	Kr <sup>88</sup>
15	458	$2.40 \pm 0.02$	$2.90 \pm 0.15$ hrs	Kr <sup>88</sup>



TABLE II

Decay Scheme of Parent Isotopes [2]

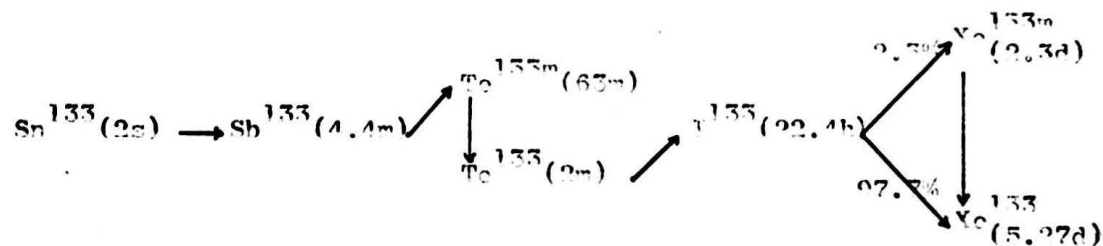
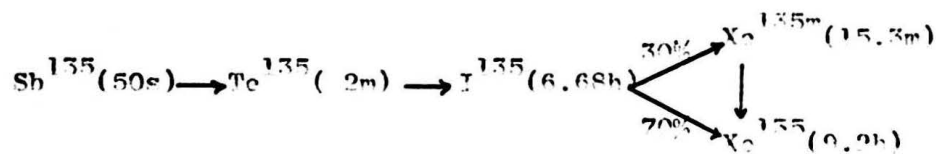
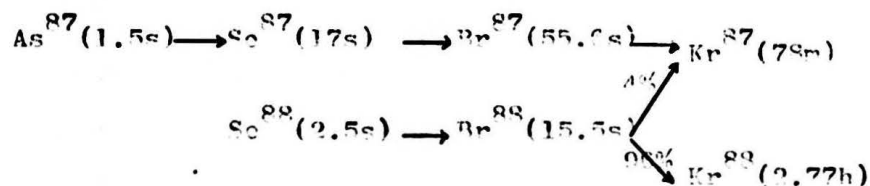
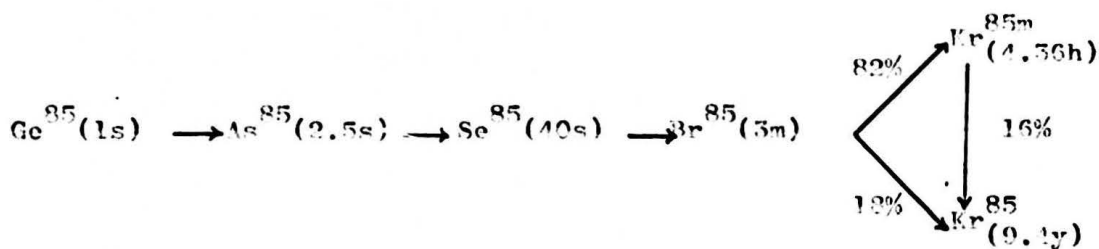
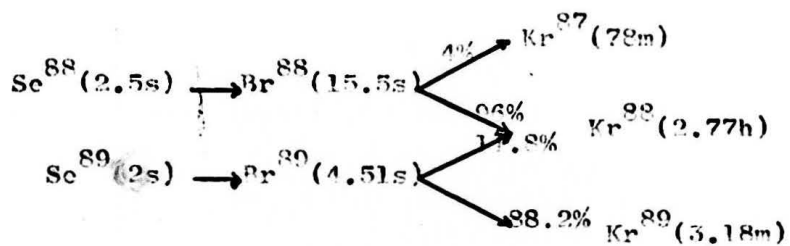
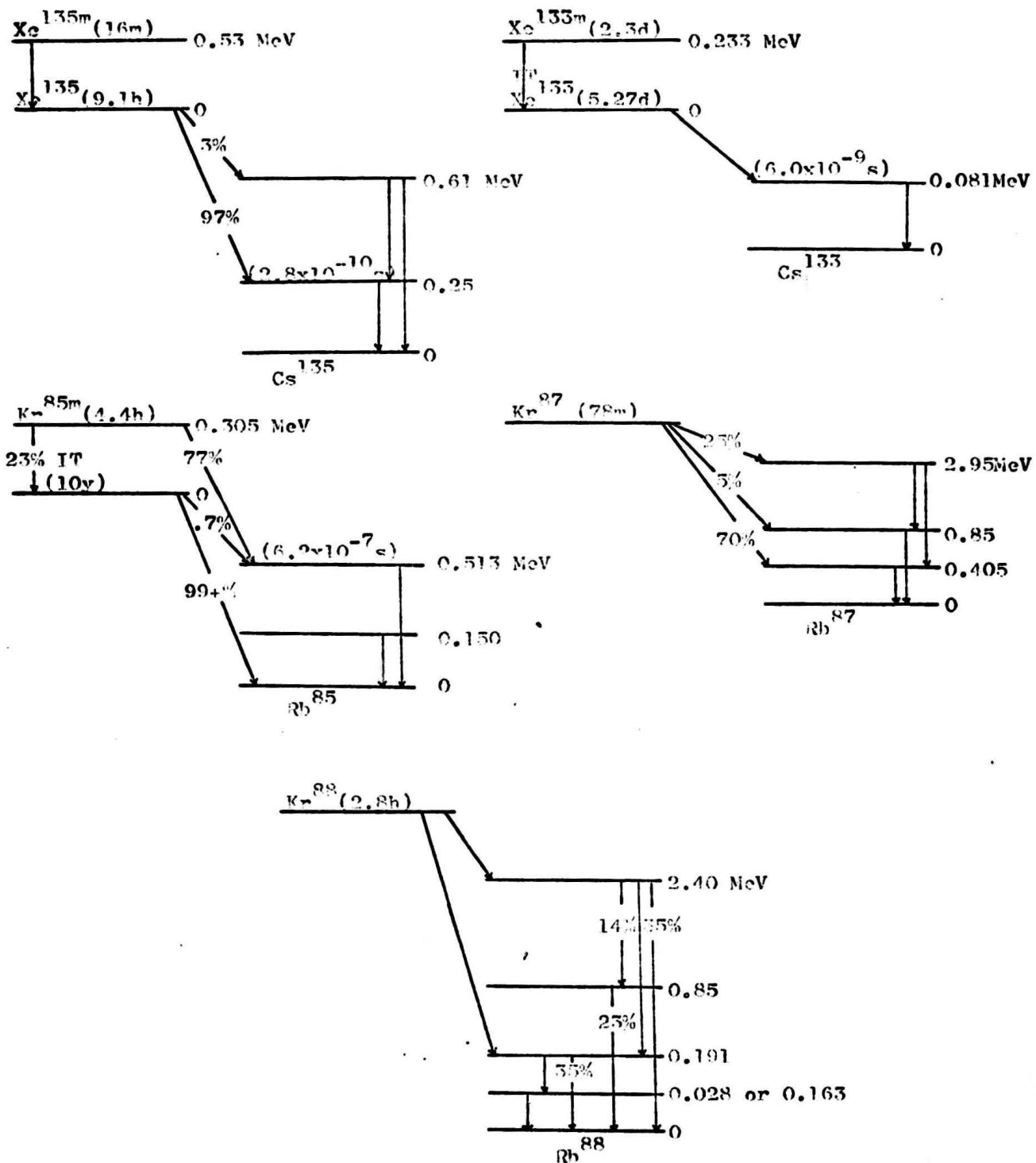

TABLE IIb

Decay Schemes of Identified Isotopes [10]



photopeak except photopeaks 8 and 14 are included as Appendix II. Data on the decay of photopeaks 8 and 14 was not obtained in that these photopeaks were masked by adjacent photopeaks; yet it was concluded that these photopeaks were due to gamma-rays from the decay of  $\text{Xe}^{135}$  and  $\text{Kr}^{88}$  respectively.

Photopeaks 1, 2, 3, 4, and 5 were well defined but the remaining photopeaks were not. In particular, photopeak 9 at times appeared to be two photopeaks of nearly the same energy and half-life as can be seen in the spectra in Appendix I. The same may be true of photopeak 15. At times it appeared that an additional photopeak of approximately 2.55 MeV gammas was masked by photopeak 15 and its decay curve paralleled that of photopeak 15. The sources for photopeaks 10, 11, and 13 could not be identified and it is possible that one or all may be distinctive points in the Compton spectrum of photopeak 15, although no similar distinctive points were observed in the Compton of any of the known isotopes used as references to determine the shape of the Compton spectrum. Photopeaks 8 and 14 were at all times masked by adjacent photopeaks.

To obtain more accurate half-lives and more certain identification of the sources for photopeaks 8 through 15 a "spectrum stripping" procedure to remove the spectrum of  $\text{Kr}^{88}$  from the raw spectrum would have to be employed utilizing an active sample of isotopically pure  $\text{Kr}^{88}$ .

Several of the lesser photopeaks of the isotopes

TABLE III

Gamma-rays Emitted by Radioactive Nuclei [6]

Isotope	Half-life	Energy MeV	Photopeak	Intensity	
Kr <sup>85m</sup>	4.36 hour	0.14950	3	57	
		0.3050	6		
Kr <sup>87</sup>	78 min.	0.0403	7	100	
		0.85	Not Obs.		
		1.75	Not Obs.		
		2.05	Not Obs.		
		2.57	Not Obs.		42
Kr <sup>88</sup>	2.77 hour	0.028	Not Obs.	20	
		0.166	Not Obs.		
		0.191	4		100
		0.36	Not Obs.		14
		0.85	9		65
		1.55	12		40
		2.19	14		
2.40	15	100			
Xe <sup>133</sup>	5.270 day	0.030*	1		
		0.0809	2		
Xe <sup>133m</sup>	2.35 day	0.2328	5		
Xe <sup>135</sup>	9.13 hour	0.250	5		
		0.36	Not Obs.		
		0.60	8		

\* Cesium x-ray

identified could not be found as is indicated in Table III. It is assumed that these peaks were masked by the more prominent photopeaks.

The spectra assigned to each identified isotope are compared with the original spectrum in the graphs included as Appendix III.

b. Quantitative results. The spectrum was broken down into 15 photopeaks and the activity associated with each photopeak calculated. These results are summarized in Table IV and Table V. A sample drawn after a peak power operation on 14 March 1966 was selected for quantitative analysis. The Energy vs. Channel Number Curve for 14 March is included as Appendix IV. Prior reactor operation that day (14 March 1966) was as follows:

From 1441 to 1442 at 1000 watts
1512 1513 1000 watts
1538 1539 1000 watts
1558 1559 1000 watts
1637 1658 100 watts

Gas sample taken 1800.

The reactor was not operated on the previous day (13 March) and the reactor core was reduced to atmospheric pressure prior to reactor operation on 14 March 1966.

As can be seen from Table V, the most significant contribution to the total activity of the reactor gas two hours after high power operation is from the isotope  $\text{Kr}^{88}$ , the activity of which accounts for approximately half the total activity. At about two hours after high power operation the activity due to the presence of  $\text{Xe}^{133}$  is still increasing and continues to increase for about 20

TABLE IV

## Activity Associated with each Photopeak

Photo- Peak	Energy MeV	Peak-to- Total Ratio	Count in 10 min.	Activity Micro- Curies/ml. $\times 10^{-3}$
1	0.030	.99	858,700	$27.6 \pm 4.5$
2	0.081	.98	1,188,700	$39.1 \pm 5.8$
3	0.148	.925	813,700	$28.4 \pm 3.8$
4	0.19	.99	634,900	$23.2 \pm 2.9$
5	0.23&0.25	.81	362,600	$14.4 \pm 1.7$
6	0.30	.75	198,800	$8.5 \pm 0.9$
7	0.40	.65	656,700	$32.5 \pm 3.2$
8	0.61	.505	35,000	$2.2 \pm 0.2$
9	0.86	.375	213,600	$18.4 \pm 1.5$
10	1.22	.295	33,000	$3.6 \pm 0.3$
11	1.4	.265	25,800	$3.1 \pm 0.2$
12	1.55	.245	40,400	$5.3 \pm 0.3$
13	1.87	.210	202,400	$31.1 \pm 1.5$
14	2.19	.185	115,100	$20.1 \pm 0.9$
15	2.40	.170	481,900	$104.5 \pm 4.4$
Entire Spectrum At time drawn			11,156,157	$363 \pm 3.4$
Four Hours later			5,692,584	$183 \pm 1.7$
Fourteen Hours later			3,481,355	$112 \pm 1.1$

TABLE V

Activity Associated with each Identified Radioactive Isotope

Isotope	Photopeaks	Activity micro-curies per ml $\times 10^{-3}$	% Total Activity at time sample was drawn
Kr <sup>85m</sup>	3 and 6	36.9 $\pm$ 4.7	10.2
Kr <sup>87</sup>	7	32.5 $\pm$ 3.2	9.0
Kr <sup>88</sup>	4, 9, 12, 14 and 15	172 $\pm$ 10	47.4
Xe <sup>133</sup>	1 and 2	66.7 $\pm$ 10.3	18.4
Xe <sup>133m</sup>	5	0.7 $\pm$ 0.2	0.2
Xe <sup>135</sup>	5 and 8	15.9 $\pm$ 1.7	4.4
Unknowns	10, 11, and 13	37.8 $\pm$ 2.0	10.4

hours at which time it has approximately doubled. This increase combined with the decrease in activity from the shorter half-life components, results in the activity due to the presence of  $Xe^{133}$  becoming the most significant activity of any duration.

This was concluded by C. C. Grissom for this reactor in that

From the absolute counting rate it is determined that the activity of the gas ranges from  $1.7 \times 10^{-1}$  to  $1.3 \times 10^{-2}$  micro-curies per cc of gas at approximately  $70^{\circ}F$  and 70cm of Hg for the gas which ranges in age from 12 to 48 hours. Of this amount, the maximum activity due to the presence of any radioactive iodine is less than 0.2% of the total activity. At 48 hours approximately 70% of the activity is due to the presence of  $Xe^{133}$  and its isomer and approximately 30% of the activity occurs as a result of  $Xe^{135}$  being present.[]

## 6. Conclusions

An analysis of the gamma spectrum of samples of reactor gas drawn at approximately two hours after peak power operation of the reactor resulted in the identification of the sources of the gamma activity. The most actively decaying radioactive isotopes present are  $Xe^{133}$ ,  $Xe^{135}$ ,  $Kr^{85m}$ ,  $Kr^{87}$ , and  $Kr^{88}$ . Based on quantitative calculations for a sample drawn at two hours after peak power operation, the total activity is  $0.363 \pm 0.004$  micro-curies per milliliter.



Of this total,  $\text{Kr}^{88}$  contributes  $0.172 \pm .010$  micro-curies per milliliter or about 47% of the total activity.  $\text{Xe}^{133}$  contributes  $10674 \pm .0105$  micro-curies per milliliter or about 18% of the total activity.  $\text{Kr}^{85\text{m}}$  contributed  $0.0369 \pm .0047$  micro-curies per milliliter or about 10.2%.  $\text{Kr}^{87}$  contributed  $0.0325 \pm .0032$  micro-curies per milliliter or about 8.9%.  $\text{Xe}^{135}$  contributed  $0.0159 \pm .0017$  micro-curies per milliliter or about 4.4% of the total activity. In addition the sources of significant points in the gamma spectrum at 1.2, 1.4, and 1.87 Mev could not be identified. These were treated as photopeaks and their combined activity was  $0.0378 \pm .0020$  micro-curies per milliliter or about 10.4% of the total activity.

A more reliable quantitative analysis and breakdown of the gamma spectrum can be made utilizing computer techniques such as those of Strickfaden and Kloepper.<sup>[5]</sup> Their computer program was not readily adaptable to the CDC 1604 and was not used in this analysis. The general techniques of their program for approximating the Compton distribution were utilized but the calculations carried out by hand.

## 7. Acknowledgements

I would like to thank the members of the Reactor Operating Committee who assisted in this study; Professors E. A. Milne, G. W. Rodeback, and W. W. Hawes and Mr. H. L. McFarland for their timely advice and assistance in setting up equipment and obtaining radioactive materials. I would like to thank my advisor for his counseling and assistance

throughout the entire study.

I wish to acknowledge the assistance of my wife, Helen, who helped in the organization and typing of this report and who assisted greatly in the tedious plotting and calculating necessary to break down the gamma spectrum into its components.

## BIBLIOGRAPHY

1. Grissom, C. C. Analysis of Radioactive Gas Generated by the AGN-201 Reactor at the United States Naval Postgraduate School. Thesis. 1965
2. Hankins, D. E. Radioactive Gaseous Effluents from a Homogenous Reactor. Los Alamos Scientific Laboratory. Research Report LAMS-2937; TID-4500. November, 1963.
3. Harshaw Chemical Company, Scintillation Phosphors, 2nd ed. 1962.
4. Heath, R. L. Scintillation Spectrometry Gamma-Ray Spectrum Catalogue. Phillips Petroleum Co., Atomic Energy Division. July, 1957
5. Johnson, N. R., E. Eichler and G. D. O'Kelley. Technique of Inorganic Chemistry, v. II. Interscience, 1963.
6. Mateosian, Der E. and M. McKeown. Table of Gamma-Rays Emitted by Radioactive Nuclei. Brookhaven National Laboratory. Associated Universities, Inc. May, 1960.
7. Nuclear Data, Inc. Instruction Manual. Models ND-180 FM and ND-181 F.M. 1965.
8. Perry, R. E. Absolute Neutron Flux of the AGN-201 Reactor. Thesis P 345. United States Naval Postgraduate School. 1964.
9. Strickfaden, W. B. and R. M. Kloepper. IBM 704 Programs for Unfolding Complex Gamma-Ray Spectra. Los Alamos Scientific Laboratory. Research Report LA-2461; TID-4500. 14 March 1961.
10. Strominger, D., J. M. Hollander, and G. T. Seaborg. Reviews of Modern Physics. v. 30, no. 2, part II. American Institute of Physics. April, 1958: 652-653; 710-711.
11. United States Naval Postgraduate School. Operation and Administration of Nuclear Reactor Facility. Postgraduate School Instruction, 9890.1. 31 October 1962.

A  
C  
T  
I  
V  
I  
T  
Y  
c  
p  
m

APPENDIX I

A COMPARISON OF THE ORIGINAL SPECTRUM  
WITH  
THE SPECTRUM FOUR HOURS LATER

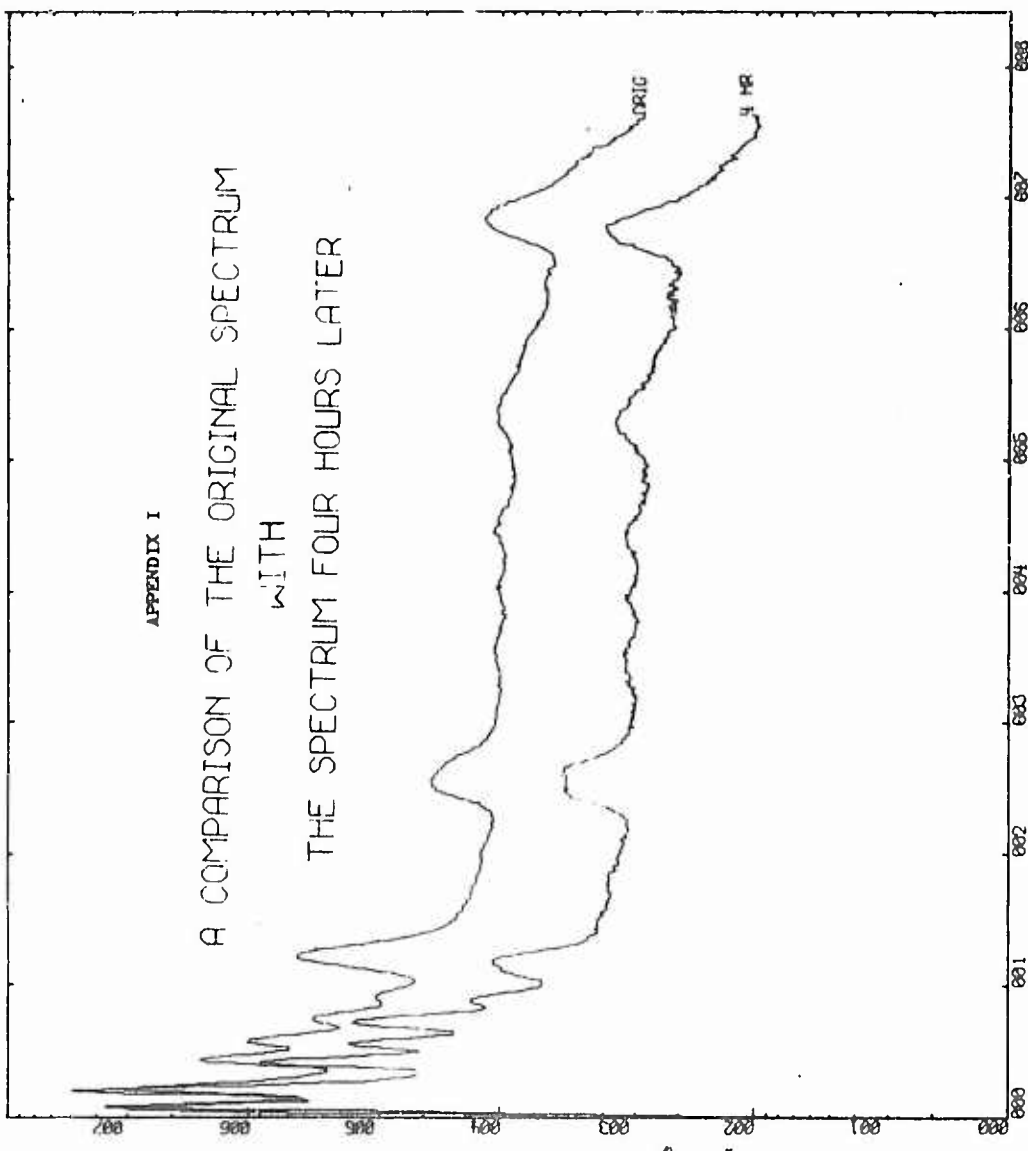

one  
decade  
per  
2  
inches

66.7 Channels/Inch

APPENDIX I

A COMPARISON OF THE ORIGINAL SPECTRUM  
WITH  
THE SPECTRUM 14 HOURS LATER

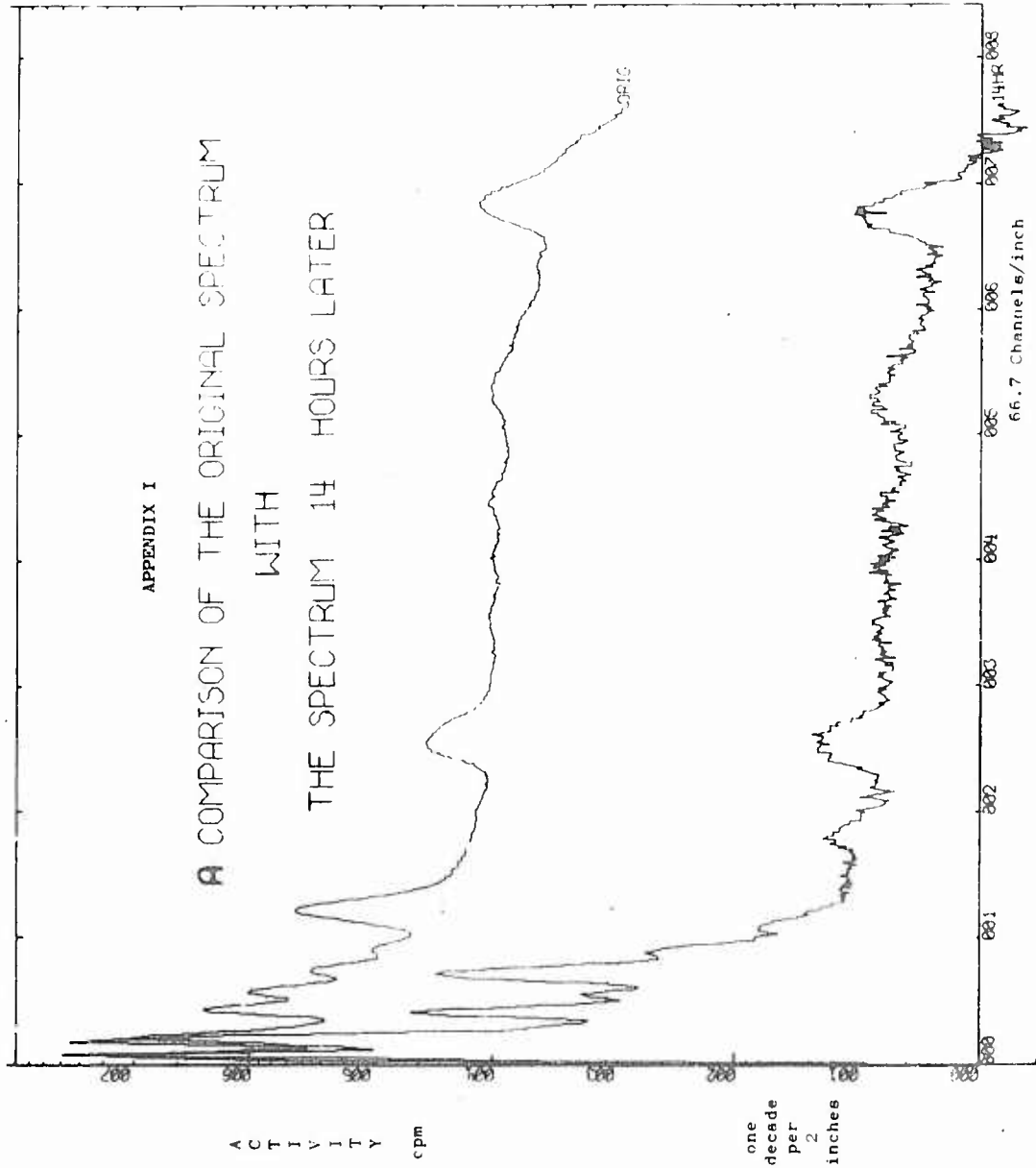

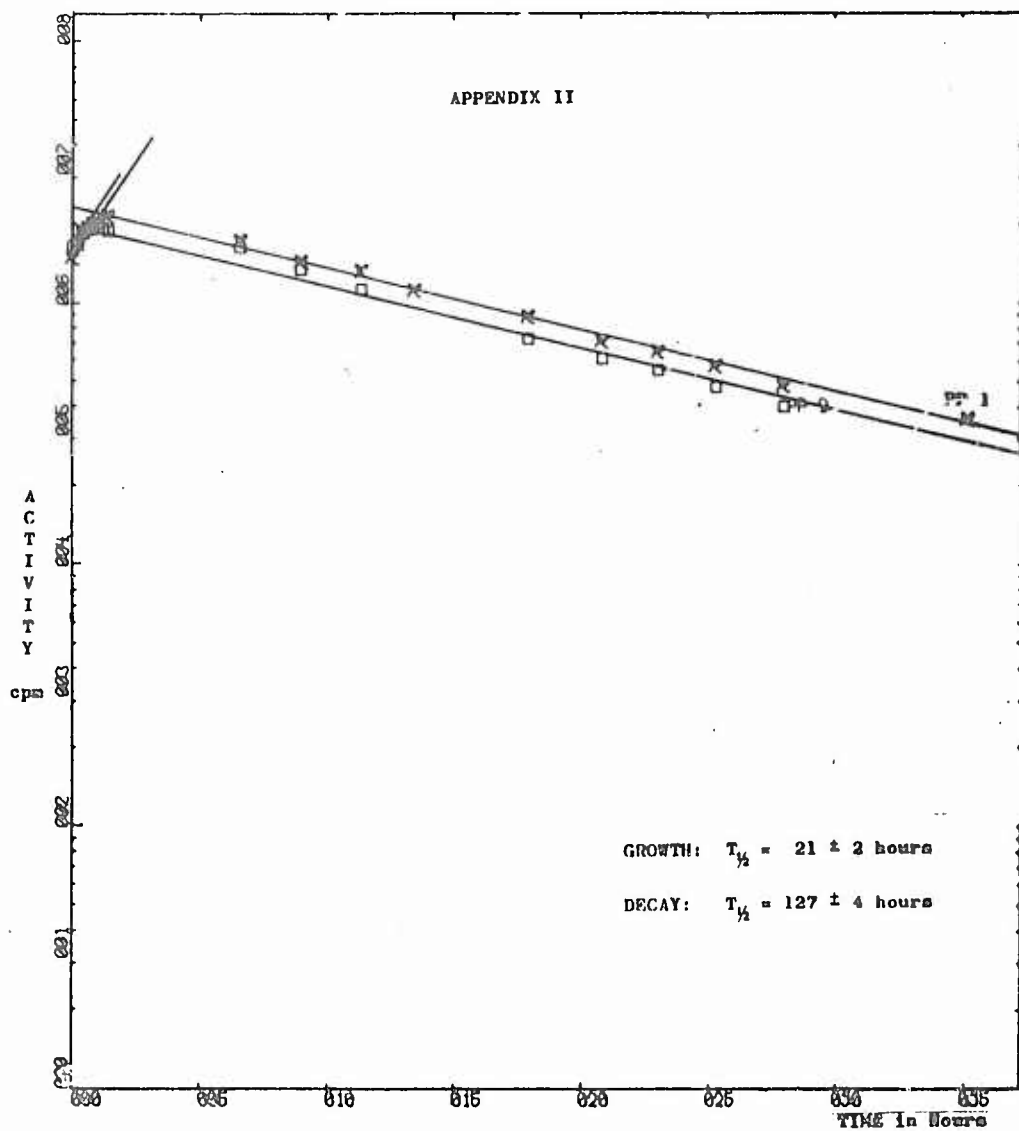

K-SCALE - 50 hours/inch  
 Y-SCALE -1 decade/2 inches  
 DECAY OF PHOTOPEAKS ONE AND TWO  
 0.030-0.081MEV GAMMAS FROM XE 133

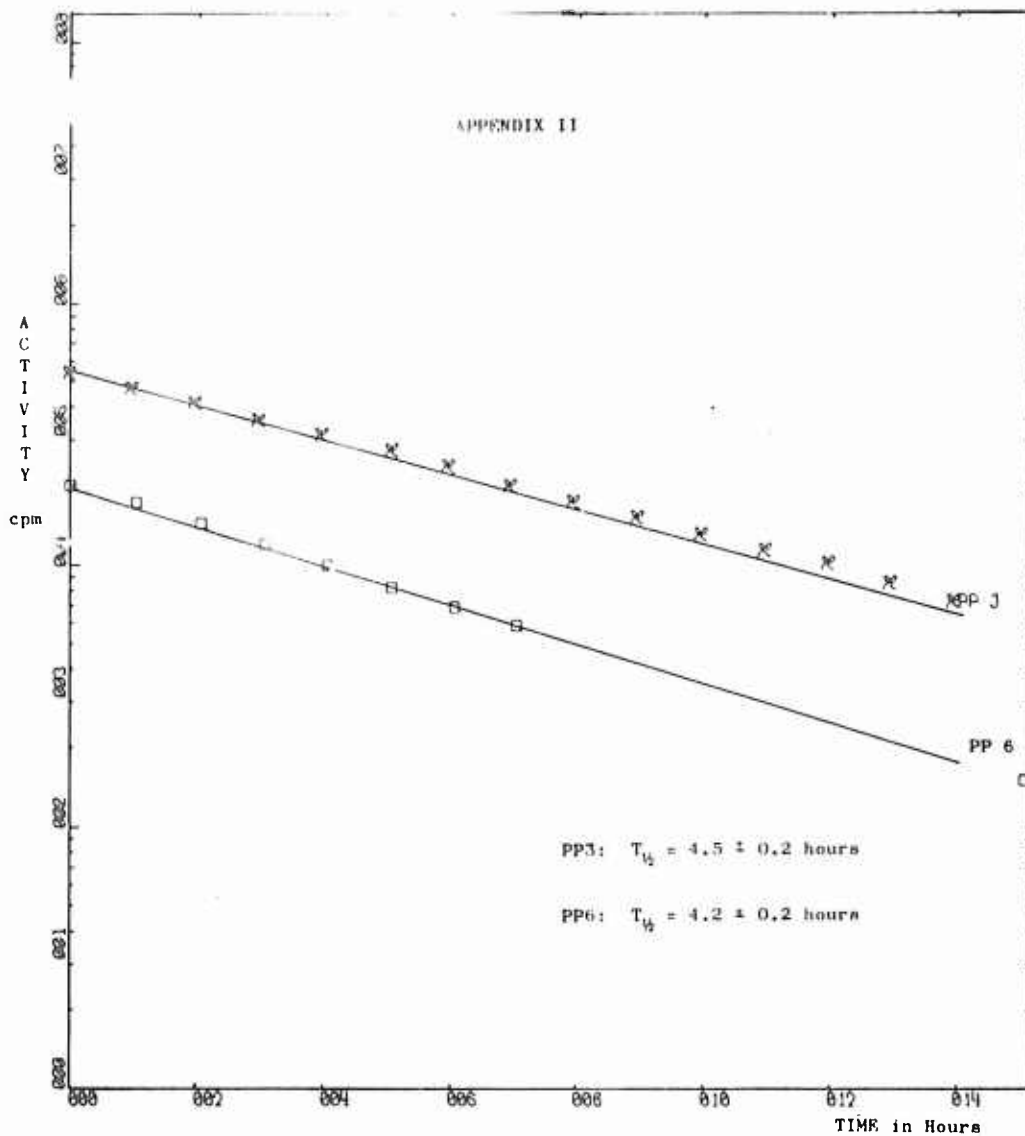

X-SCALE = 2 hours/inch

Y-SCALE = 1 decade/2 inches

DECAY OF PHOTOPEAKS THREE AND SIX  
0.15-0.305MEV GAMMAS FROM KR85M

APPENDIX II

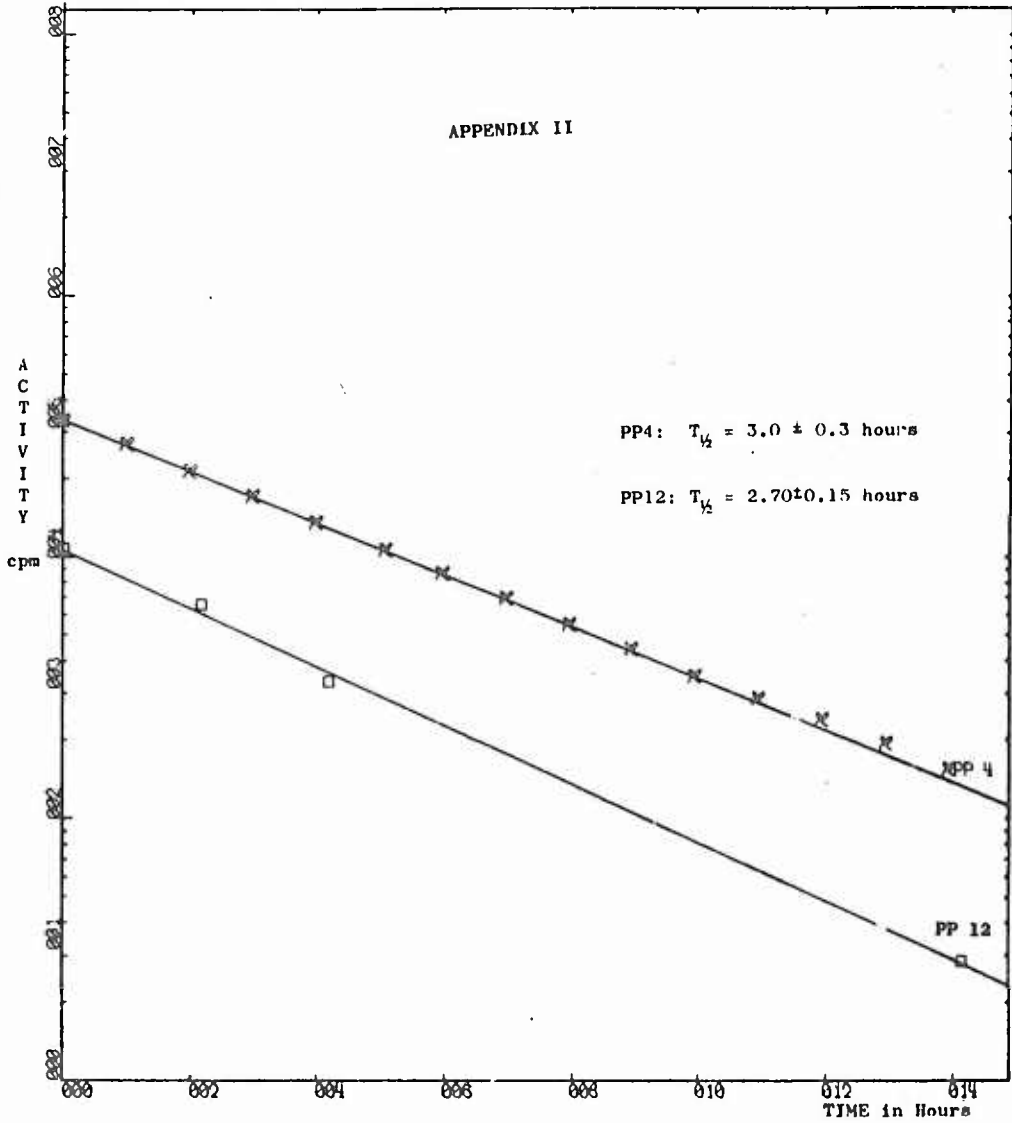

X-SCALE - 2 hours/inch  
Y-SCALE - 1 decade/2 inches

DECAY OF PHOTOPEAKS 12 AND 4  
1.55 AND .19MEV GAMMAS FROM KR88



APPENDIX II

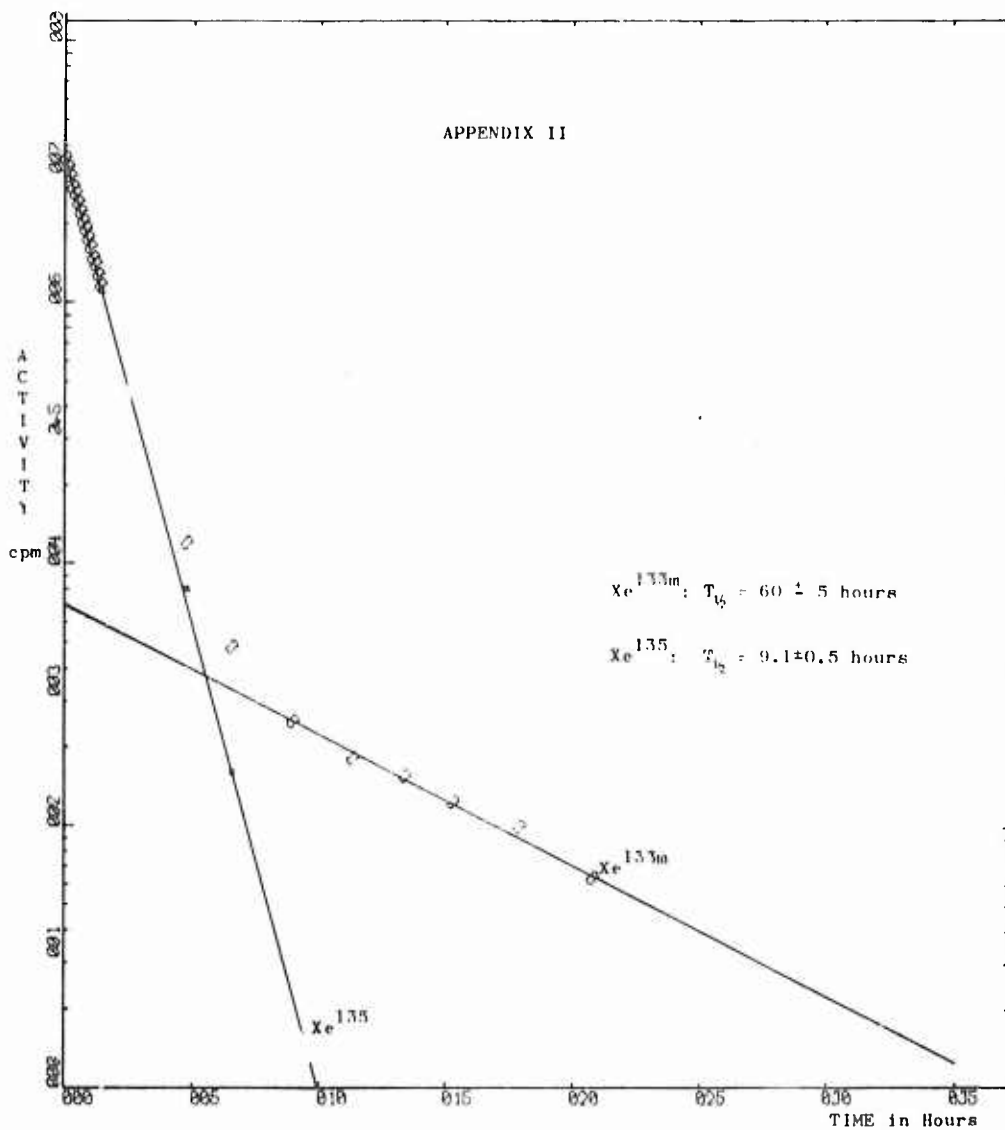

X-SCALE - 50 hours/inch

Y-SCALE - 1 decade/2 inches

DECAY OF PHOTOPEAK FIVE 0.233MEV FROM XE133M  
0.250MEV FROM XE135

APPENDIX II

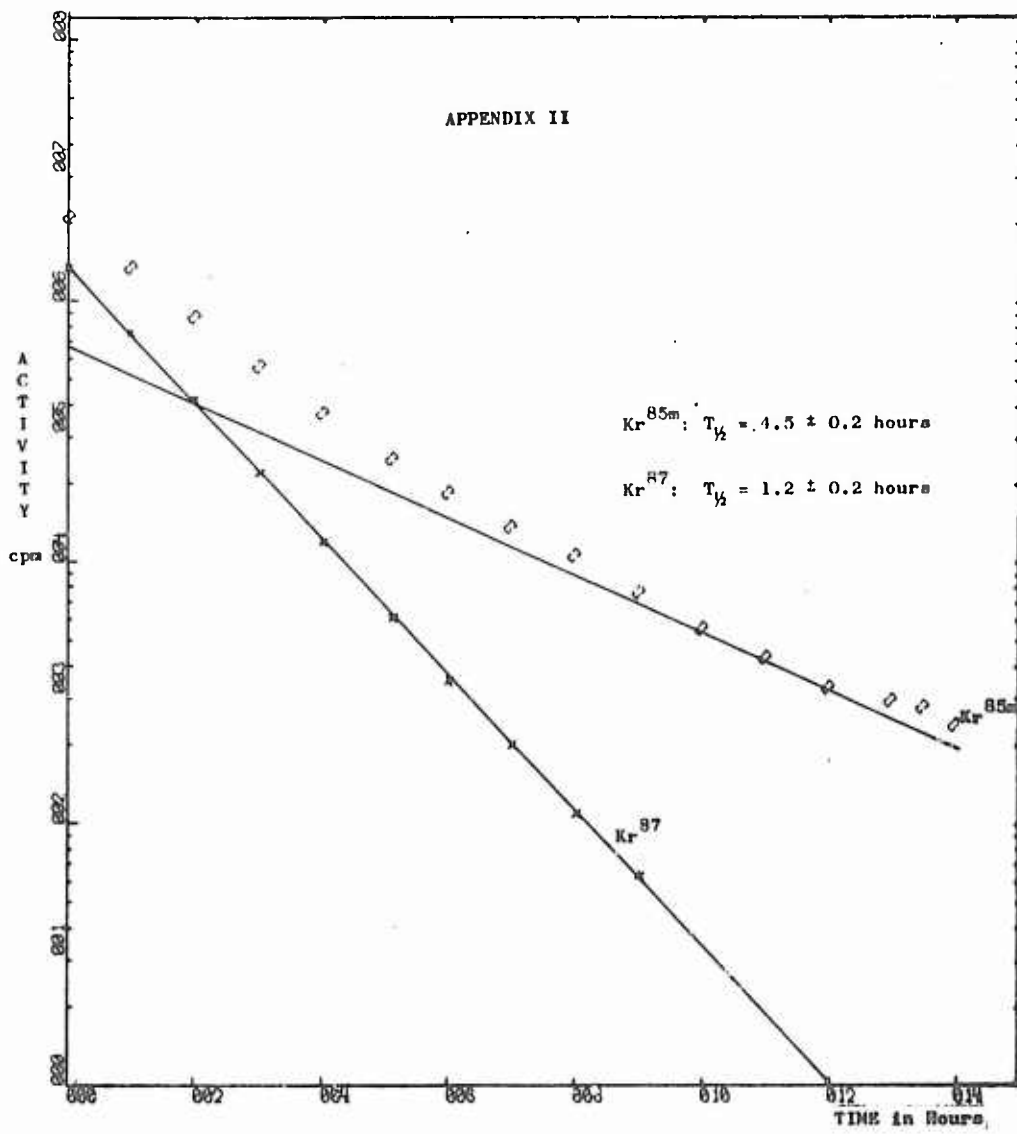

K-SCALE -2 hours/inch  
Y-SCALE -1 decade/2 inches  
DECAY OF PHOTOPEAK SEVEN  
0.40MEV GAMMAS FROM KR87

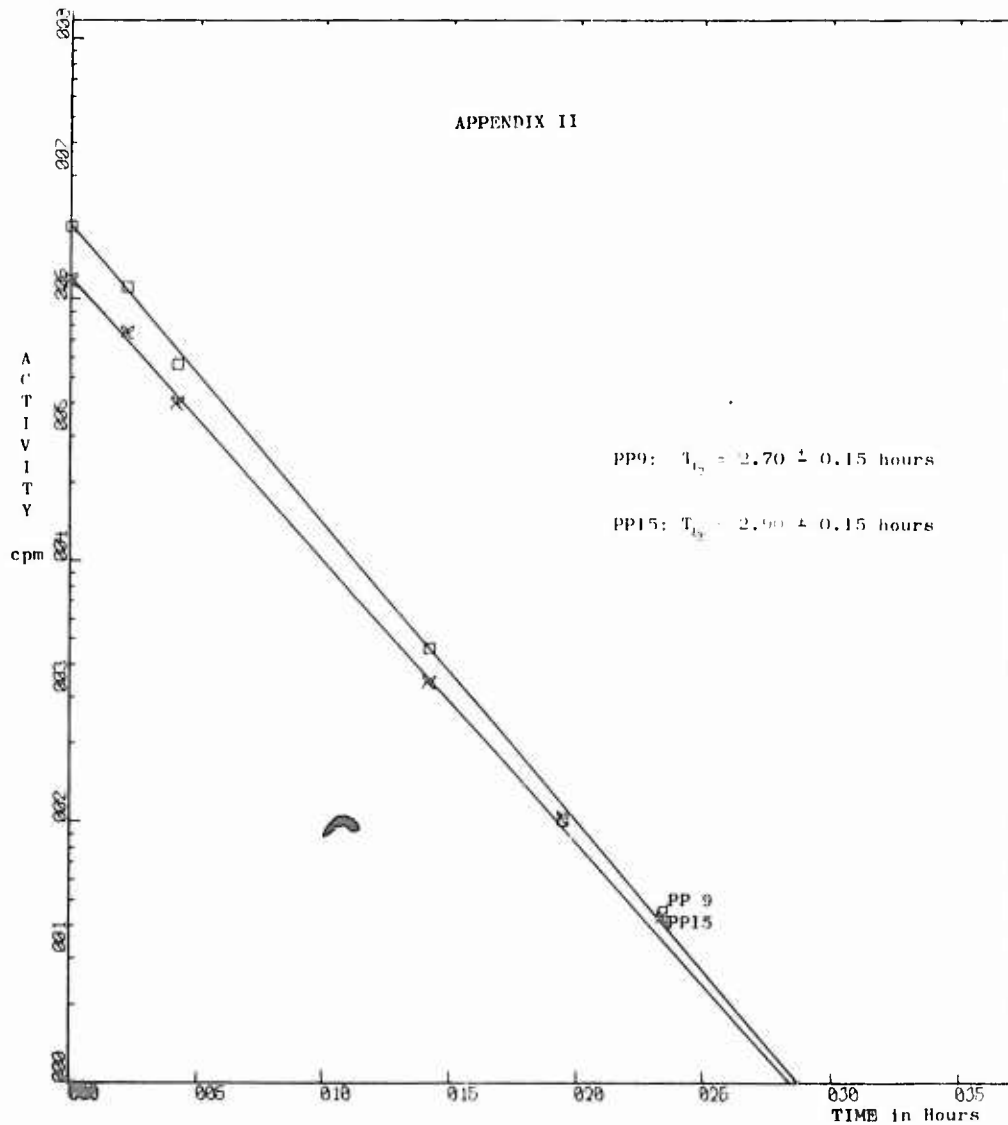

K-SCALE - 5 hours/inch

Y-SCALE - 1 decade/2 inches

DECAY OF PHOTOPEAKS 15 AND 9  
2.4 AND 0.85MEV GAMMAS FROM KR88

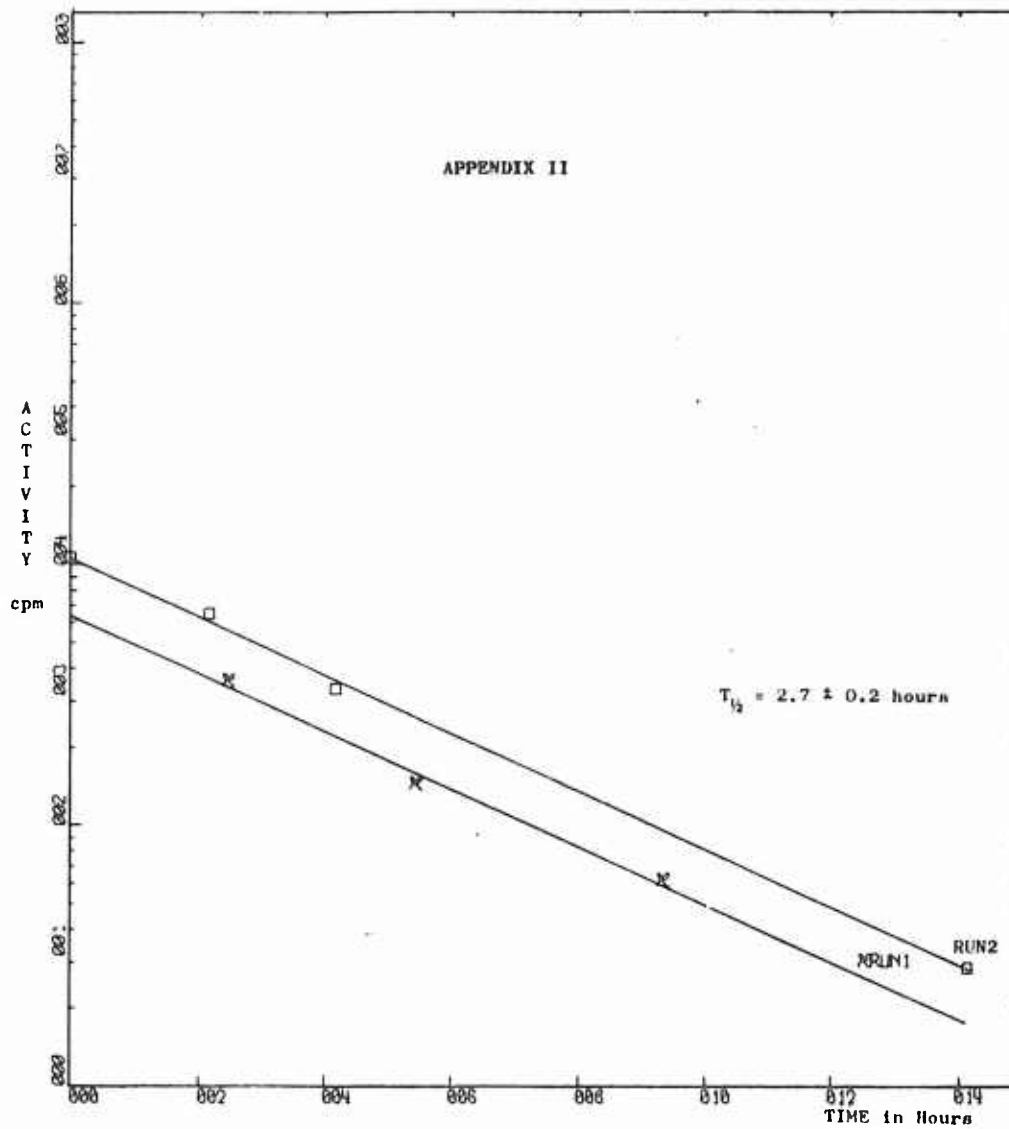

X-SCALE - 2 hours/inch  
 Y-SCALE - 1 decade/2 inches  
 DECAY OF PHOTOPEAK FROM UNIDENTIFIED SOURCES  
 1.2 MEV GAMMAS

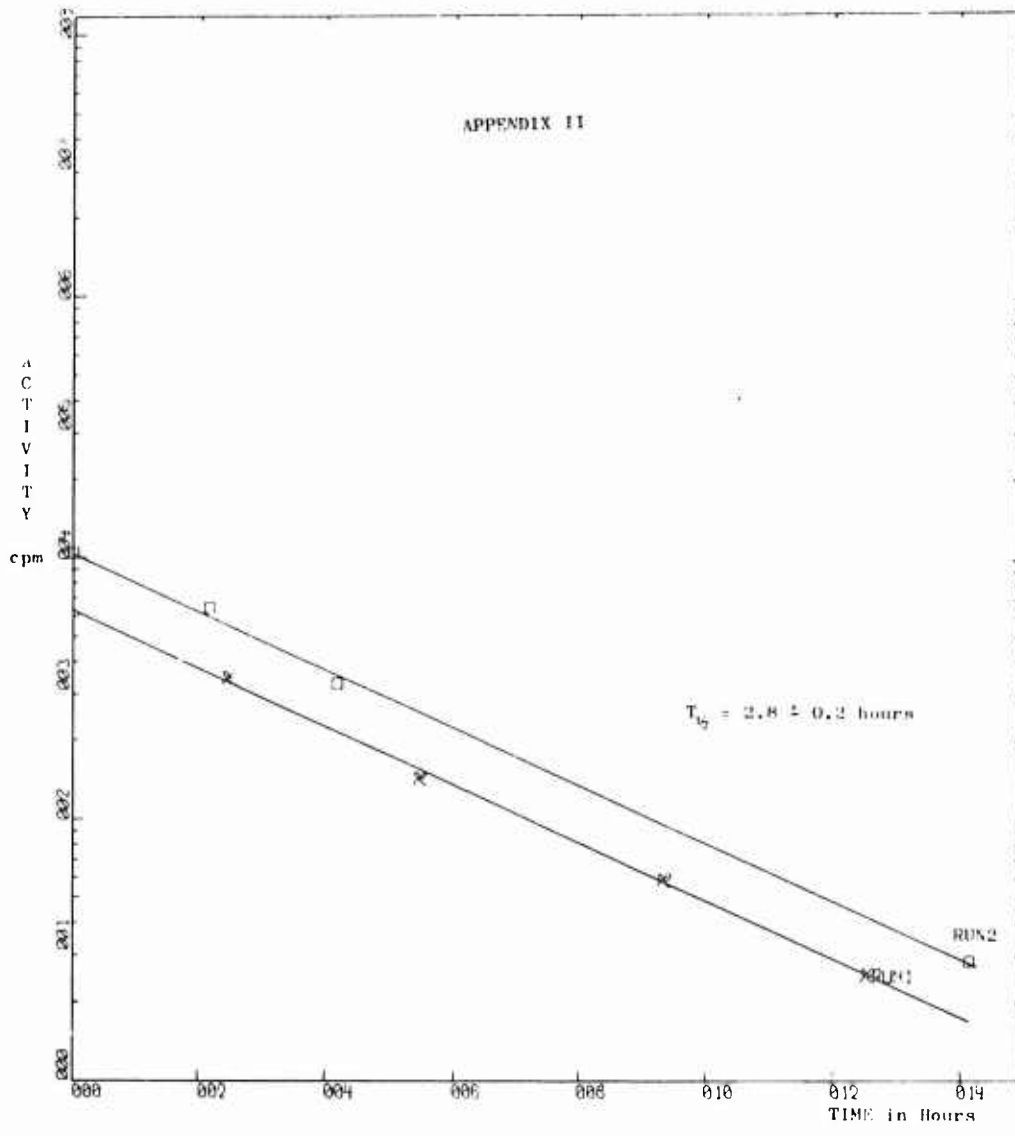

X-SCALE - 2 hours/inch  
 Y-SCALE - 1 decade/2 inches  
 DECAY OF PHOTOPEAK FROM UNIDENTIFIED SOURCES  
 1.4 MEV GAMMAS

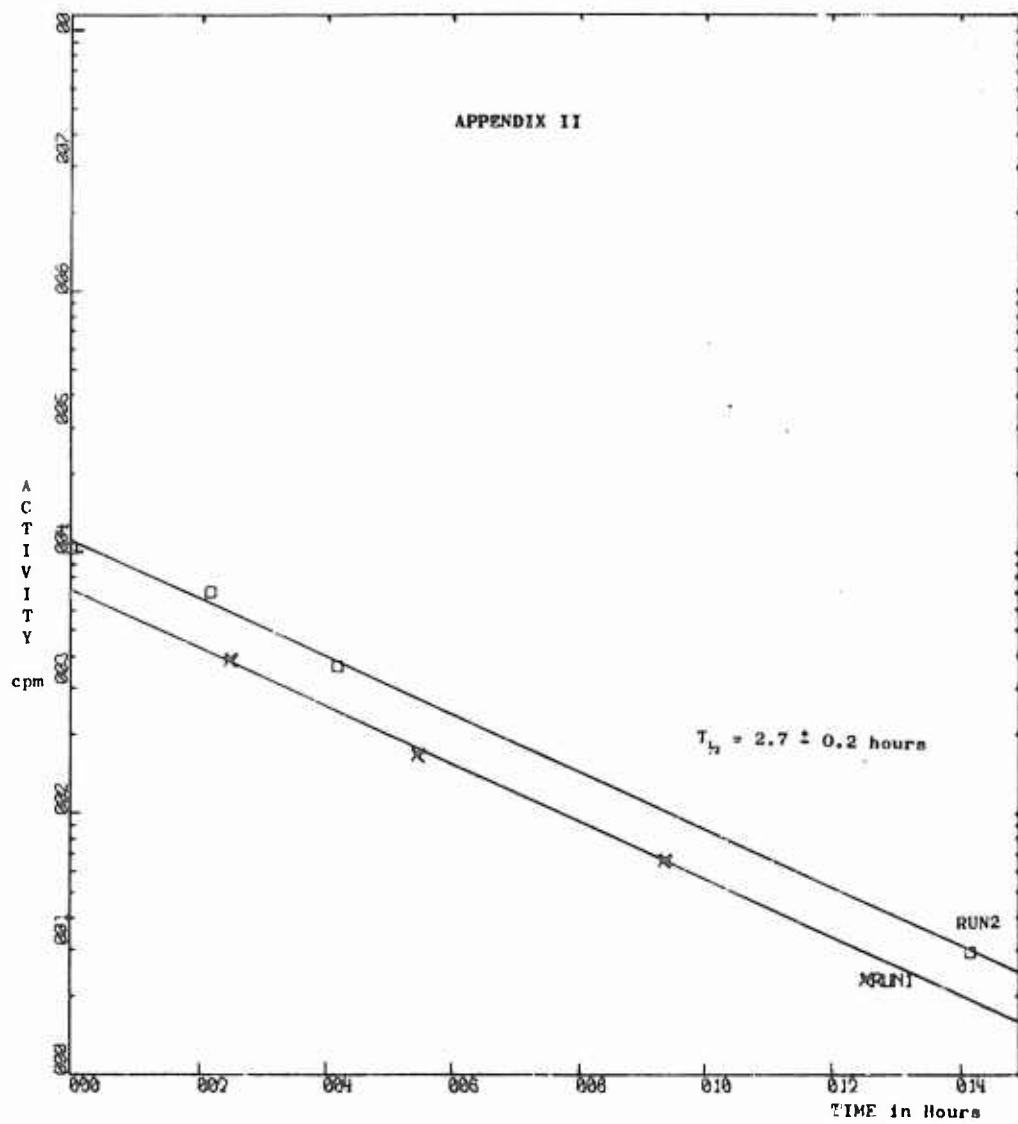

X-SCALE - 2 hours/ inch  
 Y-SCALE - 1 decade/2 inches  
 DECAY OF PHOTOPEAK FROM UNIDENTIFIED SOURCES  
 1.87MEV GAMMAS

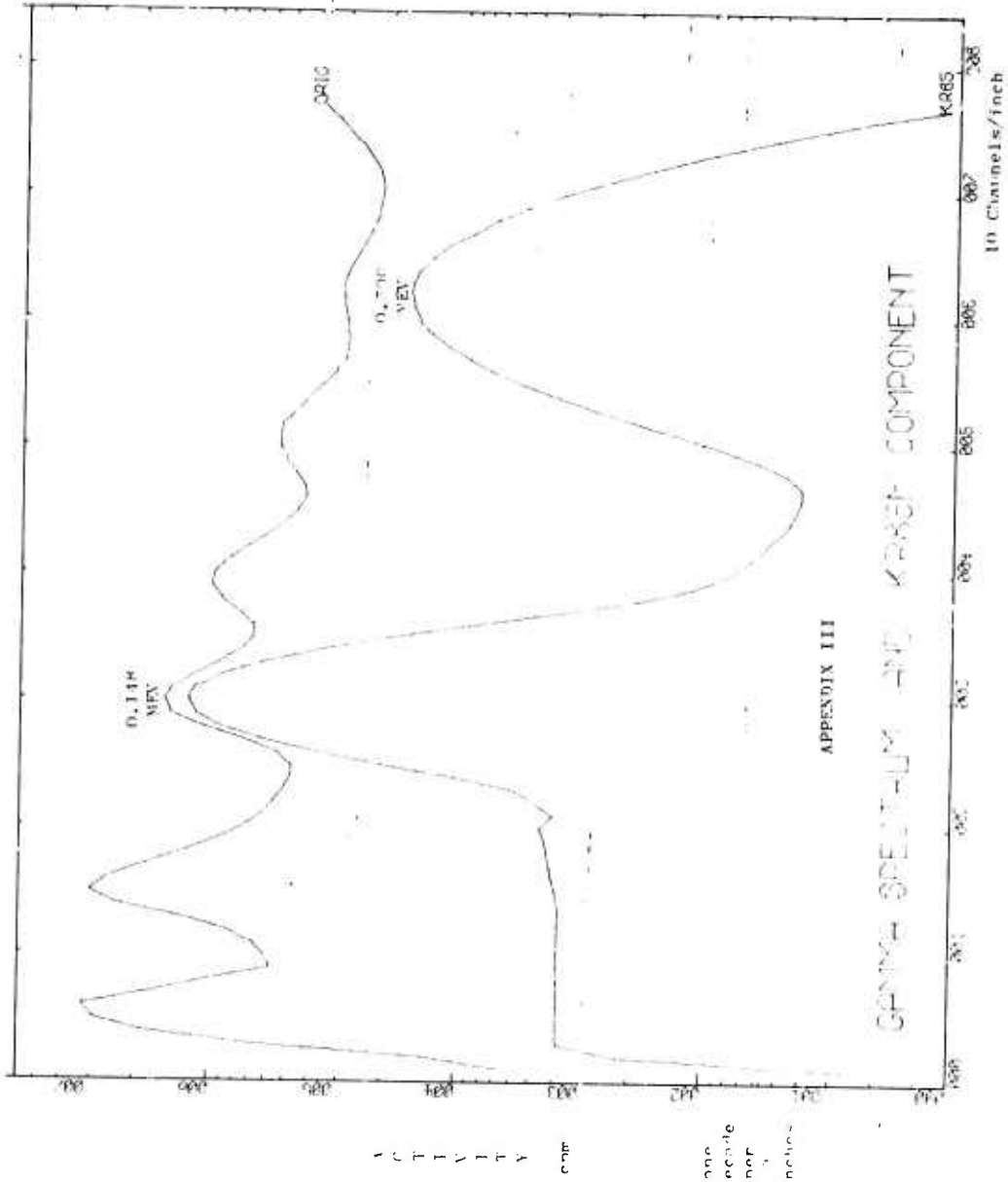

hi

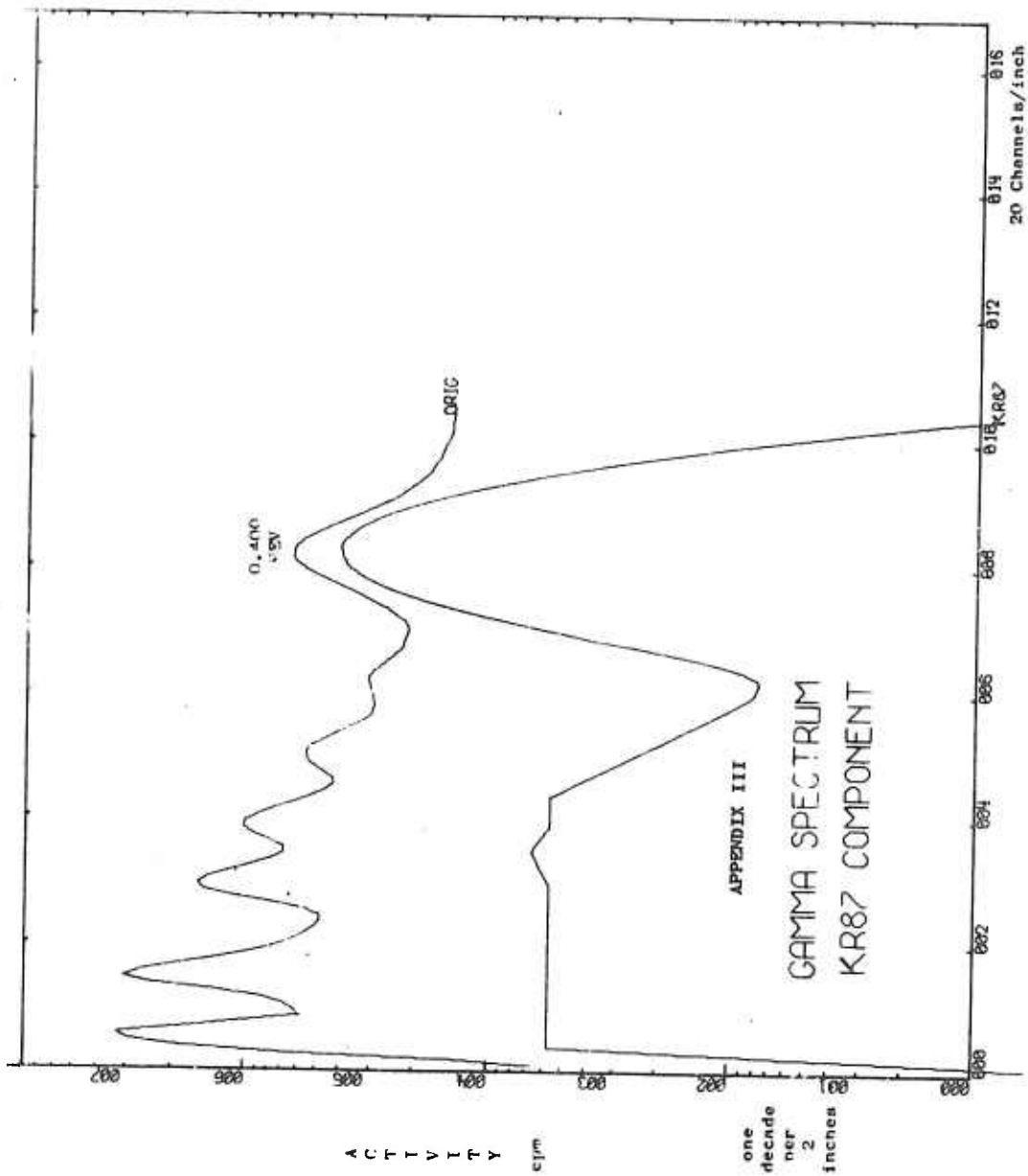



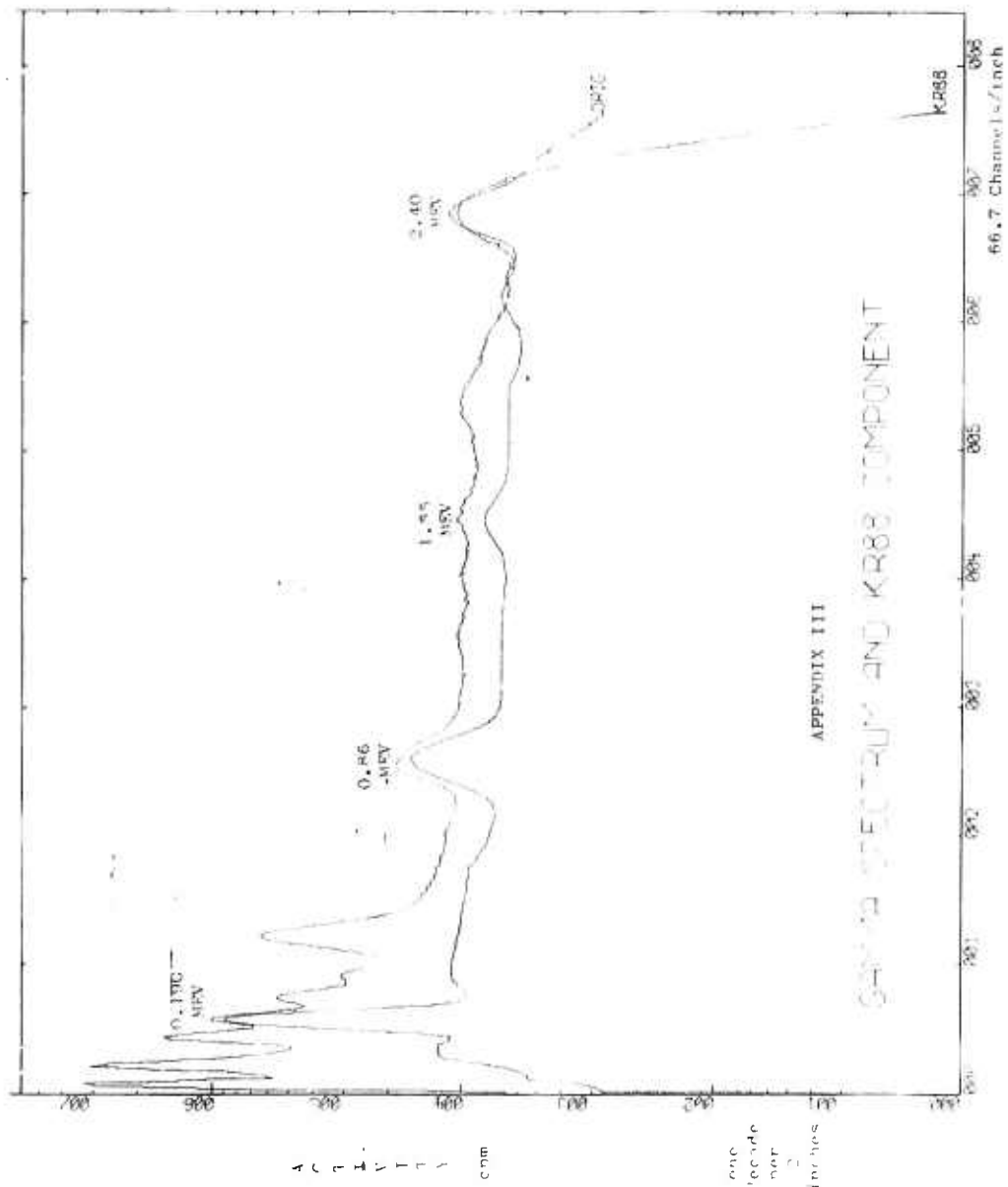

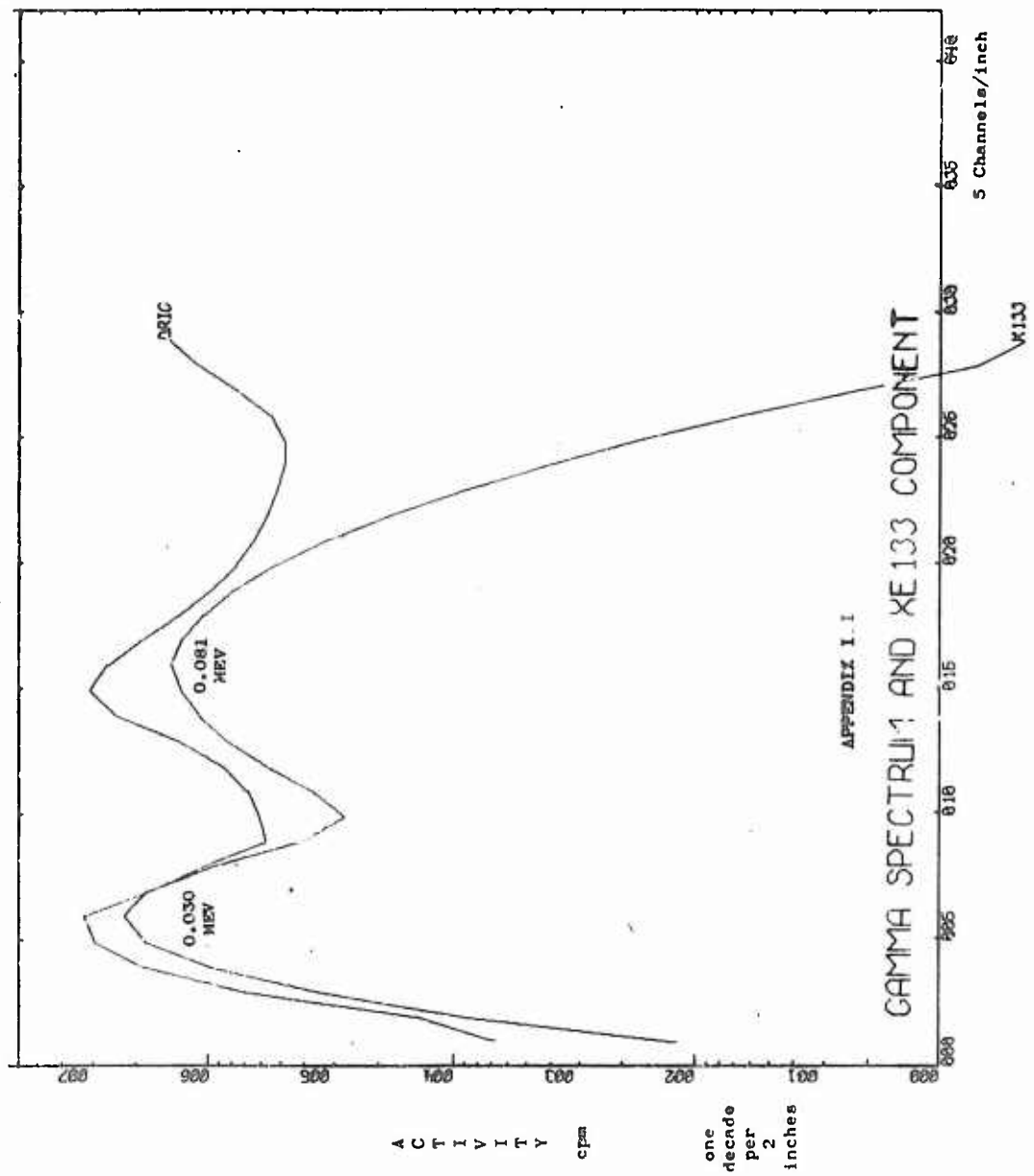

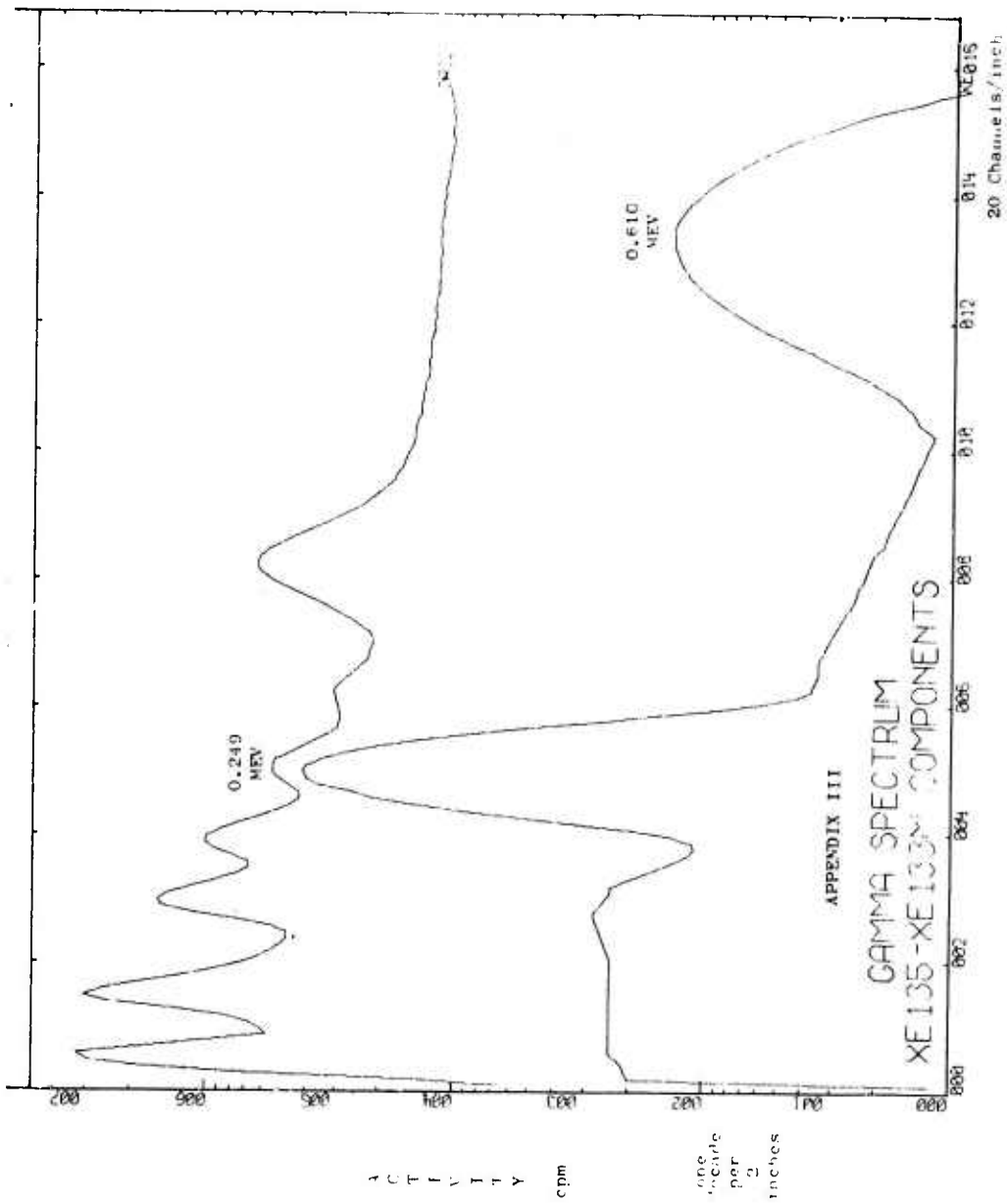

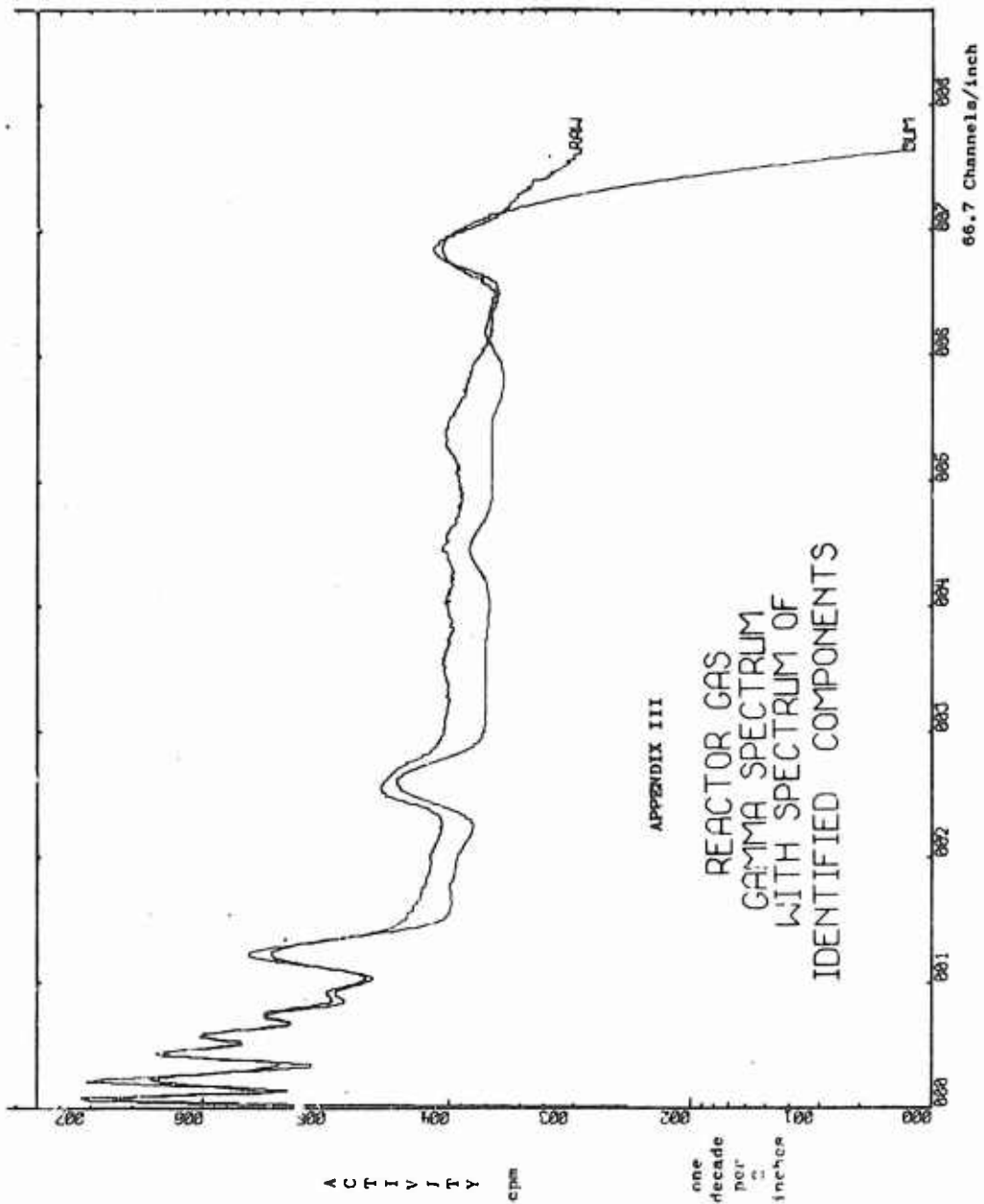

APPENDIX III  
 REACTOR GAS  
 GAMMA SPECTRUM  
 WITH SPECTRUM OF  
 IDENTIFIED COMPONENTS

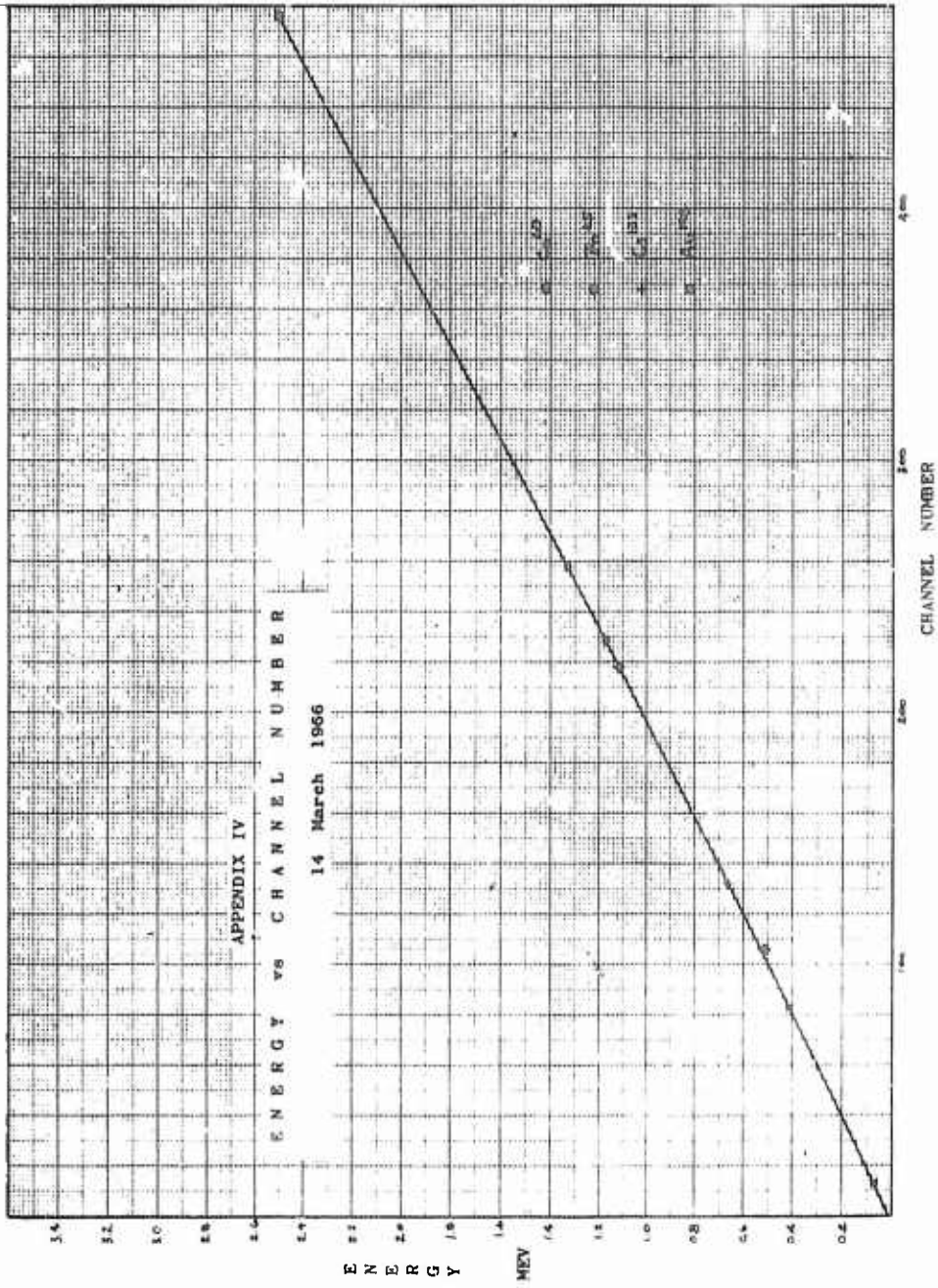

UNCLASSIFIED

Security Classification

DOCUMENT CONTROL DATA - R&D		
<i>(Security classification of title, body of abstract and indexing annotation must be entered when the overall report is classified)</i>		
1. ORIGINATING ACTIVITY (Corporate author) U. S. Naval Postgraduate School		2a. REPORT SECURITY CLASSIFICATION Unclassified
		2b. GROUP
3. REPORT TITLE Radioactive Gaseous Effluents from the Core of the AGN-201 Reactor at the United States Naval Postgraduate School		
4. DESCRIPTIVE NOTES (Type of report and inclusive dates)		
5. AUTHOR(S) (Last name, first name, initial) BREDDERMAN, Rudolf Theodore Andrew Lieutenant Commander, United States Navy		
6. REPORT DATE May 1966	7a. TOTAL NO. OF PAGES 54	7b. NO. OF REFS eleven
8a. CONTRACT OR GRANT NO.	9a. ORIGINATOR'S REPORT NUMBER(S)	
b. PROJECT NO.		
c.	9b. OTHER REPORT NO(S) (Any other numbers that may be assigned this report)	
d.		
10. AVAILABILITY/LIMITATION NOTICES Qualified requesters may obtain copies of this report from DDC		
11. SUPPLEMENTARY NOTES		12. SPONSORING MILITARY ACTIVITY
13. ABSTRACT A qualitative and quantitative analysis of the core gas generated by the AGN-201 reactor at the United States Naval Postgraduate School was made by analysis of the spectrum of gamma-rays emitted two hours after peak power operations. The principle radioactive isotopes present, based on gamma-ray photopeak energies and half-lives, were found to be Kr <sup>85m</sup> , Kr <sup>87</sup> , Kr <sup>88</sup> , Xe <sup>135</sup> , and Xe <sup>135</sup> . The total activity (gamma-ray energies $\leq$ 2.7 MeV) was found to be $363 \pm 4$ micro-curies per milliliter. The percent of the total activity due to the presence of each isotope identified in the order stated above is 10.2%, 9.0%, 47.4%, 18.6%, and 4.4%. The sources of the remaining 10.4% of the total activity were not identified.		
Previous pages were blank, therefore not filmed.		

DD FORM 1473  
1 JAN 64

UNCLASSIFIED

Security Classification

14. KEY WORDS	LINK A		LINK B		LINK C	
	ROLE	WT	ROLE	WT	ROLE	WT
Reactor Gas Xenon Gamma Spectrum Krypton Gamma Spectrum						

INSTRUCTIONS

1. **ORIGINATING ACTIVITY:** Enter the name and address of the contractor, subcontractor, grantee, Department of Defense activity or other organization (*corporate author*) issuing the report.
- 2a. **REPORT SECURITY CLASSIFICATION:** Enter the overall security classification of the report. Indicate whether "Restricted Data" is included. Marking is to be in accordance with appropriate security regulations.
- 2b. **GROUP:** Automatic downgrading is specified in DoD Directive 5200.10 and Armed Forces Industrial Manual. Enter the group number. Also, when applicable, show that optional markings have been used for Group 3 and Group 4 as authorized.
3. **REPORT TITLE:** Enter the complete report title in all capital letters. Titles in all cases should be unclassified. If a meaningful title cannot be selected without classification, show title classification in all capitals in parenthesis immediately following the title.
4. **DESCRIPTIVE NOTES:** If appropriate, enter the type of report, e.g., interim, progress, summary, annual, or final. Give the inclusive dates when a specific reporting period is covered.
5. **AUTHOR(S):** Enter the name(s) of author(s) as shown on or in the report. Enter last name, first name, middle initial. If military, show rank and branch of service. The name of the principal author is an absolute minimum requirement.
6. **REPORT DATE:** Enter the date of the report as day, month, year, or month, year. If more than one date appears on the report, use date of publication.
- 7a. **TOTAL NUMBER OF PAGES:** The total page count should follow normal pagination procedures, i.e., enter the number of pages containing information.
- 7b. **NUMBER OF REFERENCES:** Enter the total number of references cited in the report.
- 8a. **CONTRACT OR GRANT NUMBER:** If appropriate, enter the applicable number of the contract or grant under which the report was written.
- 8b, 8c, & 8d. **PROJECT NUMBER:** Enter the appropriate military department identification, such as project number, subproject number, system numbers, task number, etc.
- 9a. **ORIGINATOR'S REPORT NUMBER(S):** Enter the official report number by which the document will be identified and controlled by the originating activity. This number must be unique to this report.
- 9b. **OTHER REPORT NUMBER(S):** If the report has been assigned any other report numbers (*either by the originator or by the sponsor*), also enter this number(s).
10. **AVAILABILITY/LIMITATION NOTICES:** Enter any limitations on further dissemination of the report, other than those

imposed by security classification, using standard statements such as:

- (1) "Qualified requesters may obtain copies of this report from DDC."
- (2) "Foreign announcement and dissemination of this report by DDC is not authorized."
- (3) "U. S. Government agencies may obtain copies of this report directly from DDC. Other qualified DDC users shall request through \_\_\_\_\_."
- (4) "U. S. military agencies may obtain copies of this report directly from DDC. Other qualified users shall request through \_\_\_\_\_."
- (5) "All distribution of this report is controlled. Qualified DDC users shall request through \_\_\_\_\_."

If the report has been furnished to the Office of Technical Services, Department of Commerce, for sale to the public, indicate this fact and enter the price, if known.

11. **SUPPLEMENTARY NOTES:** Use for additional explanatory notes.
12. **SPONSORING MILITARY ACTIVITY:** Enter the name of the departmental project office or laboratory sponsoring (*paying for*) the research and development. Include address.
13. **ABSTRACT:** Enter an abstract giving a brief and factual summary of the document indicative of the report, even though it may also appear elsewhere in the body of the technical report. If additional space is required, a continuation sheet shall be attached.

It is highly desirable that the abstract of classified reports be unclassified. Each paragraph of the abstract shall end with an indication of the military security classification of the information in the paragraph, represented as (TS), (S), (C), or (U).

There is no limitation on the length of the abstract. However, the suggested length is from 150 to 225 words.

14. **KEY WORDS:** Key words are technically meaningful terms or short phrases that characterize a report and may be used as index entries for cataloging the report. Key words must be selected so that no security classification is required. Identifiers, such as equipment model designation, trade name, military project code name, geographic location, may be used as key words but will be followed by an indication of technical context. The assignment of links, roles, and weights is optional.