

UNCLASSIFIED

AD NUMBER

AD483114

LIMITATION CHANGES

TO:

Approved for public release; distribution is unlimited.

FROM:

Distribution authorized to U.S. Gov't. agencies and their contractors;  
Administrative/Operational Use; 15 DEC 1965.  
Other requests shall be referred to Air Force Systems Command, Space Systems Division, Los Angeles, CA 90009-2960.

AUTHORITY

SAMSO ltr, 28 Feb 1972

THIS PAGE IS UNCLASSIFIED

11/18/54

3

SOME CONTRIBUTIONS  
OF THE  
VEXA SATELLITE PROGRAM  
IN SPACE RESEARCH

ROBERT A. AXTELL, WAFB, USAF  
EDWARD S. JONSON, USMC

TECHNICAL REPORT SSD-TR-55-142

15 FEBRUARY 1955

**BEST  
AVAILABLE COPY**

SSD-TR-65-142

SOME CONTRIBUTIONS  
OF THE  
VELA SATELLITE PROGRAM  
IN  
SPACE RESEARCH

ROBERT C. AXI ELL, MAJ, USAF

RICHARD M. POTTER, LT, USAF

15 December 1965

THIS PROJECT IS SPONSORED BY THE  
ADVANCE RESEARCH PROJECTS AGENCY (DOD)

SPACE SYSTEMS DIVISION  
AIR FORCE SYSTEMS COMMAND  
LOS ANGELES AIR FORCE STATION  
LOS ANGELES, CALIFORNIA

## FOREWORD

This report highlights the Vela Satellite Program accomplishments for the first and second launches and some aspects of launch three. These launches were sponsored by ARPA (DoD) under ARPA Order 102 as amended. Detail Program management and responsibility was vested in AFSC SSD. We acknowledge the encouragement and technical support of the SSD Program Director for the Vela Satellite Program, Colonel Stephen H. Sherrill, Jr., USAF.

The Spacecraft were built by TRW Systems under Contract AF 04(695)-36, with radiation sensors and logics designed and fabricated by Los Alamos Scientific Laboratory (LASL) and Sandia Corp., respectively.

The authors relied heavily on LASL reports and papers. In particular, we appreciate the efforts of Dr. J.H. Coon and Dr. S.J. Bame who reviewed this report before final draft. We acknowledge, also, the technical assistance of Mr. William C. Myre of Sandia Corporation and Mr. Gene Noneman of TRW Systems.

Publication of this report does not constitute Air Force or ARPA approval of this report's findings or conclusions. It is only for the exchange and stimulation of ideas.

## ABSTRACT

The successful launches of the Vela Satellite Program have resulted in increased knowledge of the radiation environments at 17 to 18 Earth radii. Discussed in this paper are Vela Satellite Program management structure, spacecraft and payload description and a summary of the analysis of scientific data obtained from the orbiting satellites. The Vela Satellite Program achieved a space "first" by placing two similar spacecraft into high altitude circular orbits in one launch. Operational support of the satellites has been effected by efficient command and status telemetry systems. Remarkable reliability exhibited by detectors, detector logics, and spacecraft hardware has allowed data collection over an extended period. The Vela Satellites continuously sample radiation in orbits which twice cut the magnetosphere boundary. Besides confirming general features of the solar wind already observed, the satellites have supplied useful data on the following: the angular and spatial distribution of charged particles in the transition region near the magnetosphere, particle fluxes within the magnetospheric cavity, correlation of solar x-ray activity with reported solar flares, cosmic ray intensity fluctuation.

## TABLE OF CONTENTS

	<u>Page</u>
FOREWORD . . . . .	i
ABSTRACT . . . . .	ii
TABLE OF CONTENTS . . . . .	iii
LIST OF ILLUSTRATIONS . . . . .	iv
SECTION I      HISTORY. . . . .	1
A.   Mission . . . . .	1
B.   Management . . . . .	1
C.   Spacecraft Description . . . . .	3
D.   Performance . . . . .	6
SECTION II     PAYLOAD DESCRIPTION . . . . .	9
A.   XG Detector . . . . .	9
B.   Neutron Detector . . . . .	10
C.   PK Detector (Electron-Proton Analyzer) . . . . .	10
D.   XV Detector . . . . .	12
SECTION III   SUMMARY OF DATA ANALYSIS . . . . .	15
REFERENCES . . . . .	19

LIST OF ILLUSTRATIONS

<u>Figure</u>		<u>Page</u>
1	Vela Satellite Program Management . . . . .	21
2	Vela Spacecraft Cutaway View . . . . .	22
3	Spacecraft Tandem Stack . . . . .	23
4	Sequence of Events . . . . .	24
5	Spacecraft Orbit Parameters . . . . .	25
6	XG Detector . . . . .	26
7	Neutron Detector Model 3 . . . . .	27
8	Electron-Proton Spectrometer . . . . .	28
9	XV Detector . . . . .	29
10	Geocentric Solar Ecliptic Coordinate System . . . . .	30
11	Earth's Magnetosphere . . . . .	31
12	Vela Satellite Angular Distributions . . . . .	32
13	Spatial Distribution of Electron Signals (Ecliptic Coordinates) . . . . .	33
14	Spatial Distribution of Electron Signals (Magnetic Coordinates) . . . . .	34



## SECTION I

### HISTORY<sup>1</sup>

#### A. Mission

The primary objective of the Vela Satellite Program, as covered by this paper, is to conduct space-based studies to verify the feasibility of using x-ray, gamma ray and neutron detectors in satellite borne radiation detection systems. These detection systems are intended to detect and identify high altitude nuclear explosions.

The Research and Development efforts of the Program have been directed toward accumulating maximum experimental data and gaining the broadest possible understanding of basic theoretical and physical principles which are related to the detection of nuclear detonations in space. To this end, scientists and engineers of the Los Alamos Scientific Laboratory (LASL), Lawrence Radiation Laboratory (LRL), Sandia Corporation, and the Spacecraft Contractor, TRW Systems Inc., together with members of the Air Force, have been most active since 1961, the beginning of the Program.

#### B. Management

In support of the Geneva negotiations for the discontinuance of nuclear testing, plans evolved whereby the Atomic Energy Commission (AEC) would undertake laboratory development of nuclear detection instruments while the Department of Defense (DoD) through the Advanced Research Projects Agency (ARPA) and the Air Force would develop and integrate a spacecraft with these nuclear detectors. Early in the study phase of Program development, it became necessary to establish a team which could represent technical views of the AEC and the DoD. This team emerged as a Joint

Technical Group (JTG). Its members consist of scientists and engineers from LASL, Sandia Corporation, and LRL representing the AEC. DoD representation consists of a member from ARPA, the Vela Satellite Program Office Director at SSD and two other Air Force representatives. The JTG represents the focal point for AEC and DoD overall planning and management of the Vela Satellite Program. One of the main factors that has contributed directly to the success of this group is that its members are intimately aware of satellite and detector details. This awareness stems from the fact that some of the AEC and DoD members also contribute directly to satellite equipment design. In addition, the group by virtue of its small size can react to policy decisions, redirection, and guidance from either the DoD or the AEC. Any program changes which require policy or major design decisions can be acted upon immediately by the JTG whereas normal command and staff action of higher echelons could take much longer.

Figure 1 outlines the management structure which has been used to guide the Vela Satellite Program through its successful launches. On the military side of the Program, direction is from DoD to ARPA, which has the top management responsibility, through the Air Staff and Systems Command Headquarters to Space Systems Division and, hence, to the Vela Satellite Program. The Program Director is charged with detailed management of the Program. The AEC furnishes the nuclear detection sensors and associated electronic equipment as Government Furnished Equipment (GFE) to the Spacecraft Contractor. The Contractor (TRW Systems) and the others identified in Figure 1 provide hardware and services which comprise the Vela Satellite System. Launch and On-orbit tracking are provided by the 6594th and 6555th Aerospace Test Wings. The AEC, through the Division of Military Application, provided administrative support through the Albuquerque Operations Office, to LASL and Sandia Corporation. LASL is responsible for the design and construction of certain detectors and Sandia Corporation for payload logics and data reduction. LRL does AEC peculiar equipment conceptual studies. Within Space Systems Division (SSD), the Vela Satellite Program Office has been assigned responsibility for over-all system details.

To provide a workable medium through which detectors can be integrated into a spacecraft, an incentive contract has been used with the Spacecraft Contractor. This contract embodies incentive features based on cost and performance. Briefly, the cost feature is based on a realistic target cost with cost sharing arrangements. Performance incentives consist of: a 168 Hour Reliability Test, controllable error, early demonstration, and life time in paired orbit. Fee for each performance aspect of the contract varies such that excellent performance and cost control could yield the contractor a total fee of 14.9%; whereas poor performance would earn him only a 1.55% fee. For more details about incentive, consult the Vela Satellite Program Office and/or "Reliability Management of an Incentive Contract" dated May 1963, by Sam N. Lehr and Capt William S. Durham. This paper was presented at AIAA Aerospace Reliability and Maintainability Conference in Washington, DC, 6-8 May 1963.

### C. Spacecraft Description

The Vela Satellite has been designed in the shape of an icosahedron, with 18 of its 20 sides covered with solar cell panels. The remaining two sides accommodate a central cylinder which houses the injection rocket motor. This cylinder and an equipment mounting platform with support trusses constitute the main load bearing members of the spacecraft. Antennas are located at each end of the central cylinder. Reference is made to Figure 2, cutaway view of the Vela Satellites. To each antenna is connected a diplexer, receiver, transmitter and decoder. Through the use of commands, some of these units connected to one antenna can be cross switched to the other antenna. Receivers and transmitters may also be cross switched. The use of redundant subsystems is basic to the design philosophy of the Vela Satellites. This is further emphasized through the use of dual storage batteries and power converter subsystems. Even certain portions of the data handling systems for the payload and the sensors are redundant. In addition to the structure and AEC furnished payload, which will be discussed later in this paper, the spacecraft consist of the

following subsystems: Power, Propulsion, Communication, Telemetry, and Electrical Distribution. Discussion and description of each of these subsystems follows:

1. Power Subsystem

The power subsystem converts solar energy to electrical, controls and regulates this energy by means of voltage converters, and supplies the various regulated voltages required to power the spacecraft equipment. Two redundant battery packs are included to store power for use during solar eclipses and when spacecraft inclination to the ecliptic causes reduced solar cell output.

Transmitter power converters are controlled by "signal not present" relays and undervoltage sensors in addition to four commands. The relays turn off the transmitter when the receivers are not sensing a ground carrier signal. An undervoltage sensor automatically turns off the transmitter power converters when the battery bus power drops below 19.5 volts. This automatic undervoltage cut off action can be overridden by ground command. Selection of power converters for transmitters, digital telemetry units, and the certain operating section of the payload can be accomplished by ground commands.

2. Propulsion Subsystem

The propulsion subsystem includes a rocket motor and heat shield. The rocket motor is used to transfer the spacecraft from the elliptical transfer orbit to the nominal 55,000 nautical mile circular orbit. The motor is a modified Ranger BE-3 manufactured by Hercules Powder Company. The rocket motor is ignited by ground command. The heat shield is used to protect detectors and solar cells from excessive heat and exhaust products. It is ejected shortly after the motor is fired. Safety ordnance circuits protect all explosives from premature detonation.

3. Communication Subsystem

The communication subsystem performs three major functions:

(a) Receives a 374 mc carrier from ground tracking stations and transmits a carrier of 400 mc which is 16/15 and coherent with the receiver carrier.

(b) Receives and processes commands into useable signals that operate relays in the command distribution unit.

(c) Accepts any one of four modulated inputs from telemetry subsystem to transmit payload data or spacecraft status data. The output power of the transmitter is 4 watts, sufficient for the world wide Air Force tracking net to satisfactorily receive information from all satellites. The transmitters accept any one of four pre-selected modulation inputs from the telemetry subsystem to transmit data as biphased modulation on a 1024 cps subcarrier. Receivers are phased locked and provide a coherent drive output for transmitter excitation. A total of 64 commands could be used on each spacecraft. In practice to increase reliability, only 55 are used on the spacecraft of the first two launches. The third launch spacecraft have the capability to receive and respond to 128 commands.

#### 4. Telemetry Subsystem

The telemetry subsystem accepts data from the payload and processes the data for application to a biphasic modulator which in turn modulates the communication subsystem transmitter. The data from the payload can be applied to the modulator in real time or stored. The storage unit handles about 30,000 bits of payload data for later readout and transmission to the ground. In addition to payload data, this subsystem accepts spacecraft status data in the form of analog inputs. The analog inputs are processed serially and sent to the biphasic modulator for transmission to the ground. There are two redundant data storage units and two digital telemetry units with associated signal conditioner and temperature sensors. The data telemetry unit and data storage unit are selected by command.

#### 5. Electrical Distribution Subsystem

The electrical distribution subsystem, integrating all spacecraft subsystems into one functional system, consists of the command distribution unit (CDU), all electrical harnesses, launch interstage electrical equipment, and spin-up electrical equipment. With the exception of the

coaxial relays and coherent drive signal relays, the CDU contains all command relays which are controlled by the communication subsystem decoders. Almost all of the CDU relays are of the magnetic latching type; thus, a command is "stored" until the command complement is received. The CDU relays which control the coaxial cross switching relays are not the magnetic latching type. However, the relays themselves need not be energized to hold a particular position and, in effect, function as latching relays. Control and sequencing of the logics which control the status of the data storage units and the power subsystem is another vital function performed by the CDU.

Some subsystem changes were made for launch three spacecraft but will not be discussed in this paper.

#### D. Performance

During October 1963 and July 1964, the Vela Satellite Program completed two successful launches. Each launch carried two spacecraft into a circular earth orbit of about 55,000 mi. A third launch was completed in July 1965.

The spacecraft are placed on the second stage booster in a tandem stack which is represented in Figure 3. The lower spacecraft is affixed to a truss type structure which contains a small transmitter. This transmitter provides the coherent signal required for spacecraft transmitter operation during the ascent phase. A spacecraft transmitter provides telemetry data from the spacecraft. The spacecraft tandem stack is launched by an Atlas and Agena booster combination from the Eastern Test Range (ETR) in Florida. The launch sequence is portrayed by Figure 4. After the Atlas (Stage I) engine is cut off, and the nose fairing is separated, the second stage booster (Agena) is ignited for a single burn period. Upon completion of this period, the spacecraft are separated from the Agena and spun up by the gas system installed between the two spacecraft. Several seconds after spin up, timers actuate pyrotechnics which release springs that separate each of the spacecraft from the spin-up interstage. When the

spacecraft have reached first apogee, their rocket engines are aligned parallel to the circular orbit. This is approximately 19 hours after launch. One of the two spacecraft is injected into its final circular orbit while the other follows a highly elliptical trajectory. At second apogee (approximately 56 hours after launch) the second spacecraft is injected into a circular orbit. At this time, the spacecraft are approximately 140 degrees apart. Depending upon the final velocity, these spacecraft will close or open with respect to each other. Orbit parameters of the first and second launch spacecraft are summarized in Figure 5 (Orbit Parameters).

Subsystem performance to date has been outstanding. The initial feasibility mission of the Program has been demonstrated and much is being learned about the natural background of space traversed by these satellites. The redundant design inherent in all Vela Satellites have contributed greatly to the success of data gathering. There have been some minor problems. Nevertheless, all spacecraft have survived their semi-annual eclipses. It is of interest to note that more than two (2) billion bits of information have been collected so far. A large percentage of this information has been analyzed through the use of the computers by LASL. Section II of this paper will deal specifically with the scientific data resulting from the first two successful launches. Sandia Corporation processes data tapes received from the AF Satellite tracking network headquarters at Sunnyvale, California.

In reviewing the elements contributing to the success of the Vela Satellite Program, one immediately notices the importance of the team concept in R&D. This is especially true in the Vela Satellite Program where a small nucleus of 12 to 15 officers work directly with members of the Aerospace Corporation, AEC organizations and the contractors supporting the Program. These AF Project Engineers realized that they contributed directly to Program success and were therefore highly motivated. Their contributions were directly seen in, or resulted from, specification reviews, test procedure reviews, on-the-spot monitoring of contractor test and an understanding of design and interfaces. The continuity of key personnel from the AF as well as other agencies also associated with the Program from launch to launch aided undoubtedly in program success.

The fact that knowledge has been carried from one launch type spacecraft to another points out the value of a stable AF team. This team has been responsive to changing requirements and able to submit timely realistic engineering and management estimates for future programs or major modifications which increase the effectiveness of the existing Program.



## SECTION II

### PAYLOAD DESCRIPTION

The basic payloads for the three launches to date are arrays of x-ray, gamma ray, and neutron detectors. Although there are other products of nuclear explosions which might supply detectable signals, these radiations, with their characteristic fluxes dependent on type of nuclear weapon, serve the Vela deep space detection mission best. X-ray and gamma ray detectors are sensitive to charged particles, so it is necessary to also fly detectors to measure electron and proton background. The measured charged particle background, when combined with knowledge of the X and gamma detectors' charged particle sensitivity, gives the pure x-ray and gamma ray fluxes. These are correlated with known bomb yields to give detection information.

#### A. XG Detector<sup>2</sup>

X-ray detectors occupy strategic apexes on the icosahedral spacecraft frame. Any radiation source within a Vela Satellite's detection range will be seen simultaneously by at least four of these detectors. Criterion for detection is based on simultaneous signals among several detectors as recorded by coincidence logic circuits. For Launch III, a gamma sensor is housed in the same structure with each x-ray detector and the combined detection package is named the XG detector.

A Launch III XG detector schematic is shown in Figure 6. The detecting mechanism for the x-ray sensor is a cesium iodide scintillator viewed by an RCA 2067 photomultiplier tube. Cesium iodide is deposited to an average density thickness of 5 milligrams per  $\text{cm}^2$  on five 2" x 2" x 1/32" plastic facets. These scintillators are covered with three layers of beryllium filters and the five multilayer facets are assembled in a

cuical configuration. The remaining face of the cube is open to the PM tube. The gamma sensor consists of a 1.25" diameter 1" long right circular cylinder of cesium iodide shielded from bremsstrahlung by .007" of lead (see Figure 6). The scintillator is viewed by a RCA 4441 PM tube. Both X and gamma ray sensors use a single power supply. For Launch I, an alpha source and a light flasher were used for pre-flight and in-flight calibrations. For subsequent launches, the alpha source was removed before flight. The gamma ray sensor is calibrated from a monoenergetic Cesium 137 source, and the transistor light flasher allows monitoring system gain and provides for coincidence circuitry checks.

#### B. Neutron Detector<sup>2,3</sup>

Figure 7 is a schematic of the neutron detector. The detector consists of redundant proportional helium-3 counters imbedded in eight pounds of polyethylene moderator. Sensitivity of the detector is energy dependent; so, laboratory calibration is performed at several neutron energies using different neutron sources. The high voltage supply and associated electronics are contained in the detector "can". The detector is mounted on the equipment platform attached to the spacecraft central cylinder.

#### C. PK Detector (Electron-Proton Analyzer)<sup>3</sup>

As mentioned before, the neutron detector, x-ray and gamma detectors are primarily nuclear detection devices. To obtain charged particle background and generally accomplish research on effects of ambient radiation fields on primary detectors, it is necessary to develop and fly charged particle detectors. The PK detector is one such detector (Figure 8). It is a composite detector containing an electron-proton analyzer to measure charged particle flux in a 90 ev to 18 Kev energy range, and also contains a collimated type Geiger-Muller tube to measure electron fluxes above 40 Kev.

The electron-proton spectrometer (EPS) is an electrostatic analyzer constructed from concentric hemispherical plates. The acceptance aperture is fan-shaped with a  $90^\circ$  fan angle parallel to the spacecraft spin axis. The acceptance width is about  $5^\circ$ . The detector is mounted on a near equatorial apex and this, combined with the wide acceptance angle parallel to the spin axis, insures that the detector will be looking at the sun on every spacecraft revolution. Particles of the selected energy entering the analyzer aperture will be deflected through a  $155^\circ$  arc and detected by an open electron multiplier with Cu-Be dynodes which views the analyzer exit aperture.

A voltage up to two kilo-volts can be applied between the analyzer plates. This can be applied in 64 steps, thereby analyzing charged particle energies in 64 different channels. The polarity of the plates can be reversed by command, so the analyzer can be made to accept either electrons or positive ions (mostly protons). In either case, the electron multiplier detects the individual particles which, after amplification, contribute to an accumulated pulse. Twice each second, pulses are counted above two of three levels to give a three-point integral pulse height spectrum for each selectable energy. Since energies of the individual particles are known, this serves as an in-flight calibration of multiplier gain. The high voltage power supply is designed for two voltage ranges. In the event of severe loss of multiplier gain, the power supply can be commanded to the higher voltage (about a 500V increase).

The PK detector is valuable for measuring angular distributions, as well as energy spectra. The angular mapping is accomplished by sun sensors triggering timing mechanisms. A "normal" sun sensor is oriented to lead the acceptance aperture by about  $12^\circ$ . Thus, when the analyzer aperture is  $12^\circ$  from the earth-sun line, the sun sensor trigger causes counts from the multiplier to be read into accumulators for 8 millisecond counting periods (approximately  $16 \times 10^{-3}$  rev.). On the next revolution, the trigger is delayed for 8 milliseconds. In this manner a continuous angular distribution is measured within  $-12^\circ$  and  $+12^\circ$  of the earth-sun line.

Other delays are incorporated in the timing mechanism, triggering the count accumulators at  $90^\circ$ ,  $180^\circ$  and  $270^\circ$ . The result is detailed angular measurement close to the earth-sun line, in both dawn and dusk directions and in the anti-solar direction. For Launch III, PK detectors in each spacecraft have an "abnormal" sun sensor which leads or lags the "normal" sensor by  $30^\circ$ ; so sets of angles which lead and lag the normal angles by  $30^\circ$  can be monitored.

The Geiger-Muller tube is sensitive to electrons above 40 Kev and uses the sun sensor timing to obtain angular distributions of these medium energy electrons. Data from this sensor can be correlated with data from similar instruments flown on Explorer Satellites. A feature included only on the last launch is an additional GM tube with look axis directed  $60^\circ$  from the original. This makes some three dimensional angular information possible.

#### D. XV Detector<sup>3</sup>

The XV detector (Figure 9) is another research detector. In Launch II XV detectors, a scintillator PM combination obtains detailed information about solar x-rays impossible to obtain from the primary x-ray sensors in the XG detectors. Two Geiger-Muller tubes and a solid state sensor study electrons in the energy range affecting thin window x-ray detection devices. Since the detector is mainly interested in solar x-rays, the detection package is placed on a near equatorial apex of the spacecraft.

There are two pairs of scintillator PM combinations. Two PM's with the same spectral response (.8 to 20 Kev photon energy) are stacked in sensitivity to respond to fluxes from  $10^{-5}$  ergs  $\text{cm}^{-2}$   $\text{sec}^{-1}$  to  $10^{-1}$  ergs  $\text{cm}^{-2}$   $\text{sec}^{-1}$ . Denser x-ray filters are used for two similarly stacked tubes to obtain fluxes for a different energy spectrum (2.5 to 20 Kev). In real time, anode current readouts are triggered approximately once each second by a sun sensor when the x-ray sensors are oriented toward the sun. The counting trigger can also be made from the spacecraft clock with the mode of triggering being selectable by command. The sensitive PM tubes are subject to fatigue, thus when the lower sensitivity tube sees a signal above the first level, the high sensitivity tube cuts off.

The scintillator PM combinations are also quite good electron sensors. Differentiation of electron signals from x-ray signals can be accomplished by comparisons with signals from solid state sensors and Geiger-Muller counters, which are relatively insensitive to x-rays.

The Launch II solid state detector is a phosphorous diffused P-N junction with an electron threshold around 40 Kev. Individual electron pulses are analyzed in seven energy bands from 40 Kev to 400 Kev. The Geiger-Muller tubes are high flux detectors measuring particle fluxes above solid state and PK capabilities up to about  $10^6 \text{ cm}^{-2} \text{ sec}^{-1}$ . They are commercial tubes with electron thresholds of 40 Kev and 100 Kev. Each XV detector subassembly (scintillator - PM combinations, solid state sensor, GM tubes) is complete with its own input electronics, i.e., independent calibration and replacement is possible.

### SECTION III

#### SUMMARY OF DATA ANALYSIS

Analysis of real time and taped data has yielded interesting information in five areas: (1) Solar Wind Observations well away from the earth's magnetospheric boundary; (2) Charged particle angular and spatial distribution around the transition region of the magnetosphere; (3) Particle fluxes within the magnetospheric cavity; (4) Correlation of measured solar x-ray activity with reported solar flares; and (5) Cosmic ray observations.<sup>4</sup> These results are included in LASL papers presented at AGU meetings and are printed in "The American Journal of Geophysics" and "Physical Review Letters". The authors are AEC scientists responsible for the design of Vela detector devices as well as data reduction and interpretation. PK detector results are the work of S.J. Bame, J.R. Asbridge, H.E. Felthouser, R.A. Olson, and I.B. Strong.<sup>5,6</sup> Solar x-ray results are the work of J.P. Conner, T. I. Bonner, W.D. Evans, M.D. Montgomery, S. Singer and E.E. Stogsdill.<sup>7</sup> In reviewing these results, we have freely plagiarized the reports and papers listed in our bibliography.

To give a better feeling for the results, we briefly introduce some background information on the magnetosphere. We use a geocentric solar ecliptic coordinate system (Figure 10). Figure 11 is a sketch of the earth's magnetosphere. The sun-most region of the magnetosphere is the sub-solar region; the leading side as the earth makes its orbit is the dawn-side; the trailing edge is on the dusk side; and past the earth on the earth-sun line is the anti-solar region. Near the earth, the magnetic field lines approximate a magnetic dipole quite well, but further from the earth (around  $6 R_e$ ), the magnetic field lines begin to lose their symmetry and are seemingly blown away from the sun. In fact, this is just what happens with the solar wind as the instrument of deformation. A shock wave forms on the sunward side

of the magnetospheric boundary, and forms the outer boundary of the so-called transition region. There is still discussion on the orientation of field lines in the anti-solar cavity. It is generally agreed that most field lines close near the earth but Piddington, in his magnetosphere model, suggests that the high latitude lines of force may extend beyond the moon's orbit.<sup>8</sup> As mentioned, Vela data concerns particle populations in interesting magnetospheric regions and any models of the magnetosphere must recognize this data.

Using the PK electrostatic analyzer, protons in interplanetary space are observed to be streaming radially from the sun within  $\pm 2^\circ$  and to have velocities in the range of 350 to 800 Km sec<sup>-1</sup> (Figure 12 a,b,c).<sup>5</sup> There are fluctuations in the proton streaming direction with observed deviations as great as  $\pm 10^\circ$  from radial. In this region relatively few electrons are observable with energies above .3 Kev (the PK detector electron threshold). Presumably, most of the electrons in the solar wind plasma have energies below this range. These results extend the observations made by NASA Explorer satellites, and to date we have a picture of the solar wind as a sea of protons (and a lower flux of alpha particles) traveling radially from the sun at average speeds around 500 Km sec<sup>-1</sup>.

The transition region and boundary of the magnetosphere have been given special attention. This a turbulent region; PK results show protons generally streaming around the magnetospheric boundary, fluctuating in direction and energy more than in the undisturbed solar winds (Figure 12 d). The energy peaks are usually around 1 Kev, but frequently extend above 5 Kev. There are energetic electron populations in this area and these have anisotropic angular distribution (Figure 12 e,f,g). The irregularities in charged particle populations are attributed to interactions of the charged particles with the earth's magnetic field, but the mechanisms of these interactions are unknown.

Just outside the magnetospheric boundary positions transversed by the Vela satellites,  $\sim 1$  Kev protons similar to the solar wind protons stream in a well ordered manner. Just inside the boundary, the streaming

protons disappear. Thus it appears that a "proton boundary" can be defined, which is coincident with the magnetospheric boundary as observed by Explorer satellites.<sup>5</sup> Proton data from these regions suggest that the magnetosphere is slightly tilted about the earth-sun line in a way which can be attributed to the effect of the aberration in solar wind direction caused by the earth's motion in its orbit around the sun. In the anti-solar region within the magnetospheric cavity, no continually streaming solar-wind-type protons are observed. The XV and PK detectors have both seen clouds of energetic electrons (>50 Kev) in and near the magnetosphere. There are two quite interesting new observations concerning these electron populations. First, an asymmetry is observed in spatial distribution of electron clouds (Figure 13 and 14 show this asymmetry).<sup>6</sup> The frequency of shifting clouds of electrons on the dawn side of the magnetosphere is significantly greater than the observed frequency on the dusk side. Many energetic populations are seen in and near the magnetosphere as the satellites trace patterns from the anti-solar point through the dawn magnetospheric boundary, but few are seen on the dusk side of the earth-sun line. "This asymmetry may be influenced by the prevailing average interplanetary magnetic field, which from distant space approaches the magnetospheric boundary approximately normally on dawn side, but tangentially on the dusk side."<sup>4</sup>

The second new observation shows that in the anti-solar direction, energetic electron populations at 17 to 18  $R_e$  are confined to a region centered on the plane of the earth's magnetic equator and extending  $\pm 6 R_e$  from this plane (Figure 14). Apparently, these electron populations are controlled by the earth magnetic dipole. Again, the dawn-to-dusk asymmetry is observed within the confined region. The latest interpretation of data in the anti-solar regions shows electrons streaming away from the earth confined above and below the magnetic equatorial planes.<sup>9</sup> This lends credence to a current model of the tail of the magnetosphere according to which the northern and southern regions of the earth's magnetic field are separated by a magnetically neutral sheet. This sheet extends from  $\sim 12 R_e$  out to unknown distances in the anti-solar direction, perhaps far beyond the orbit of the moon.



The scintillator within the XV package monitors solar x-rays in two broad energy bands as indicated in Section II, Paragraph D. The XV scintillators see quiescent solar x-ray fluxes varying between  $2 \times 10^{-4}$  and  $10^{-3}$  ergs  $\text{cm}^{-2} \text{sec}^{-1}$  with wave lengths from .5 to  $15\text{\AA}$ . Sudden increases in solar x-ray flux usually, but not always, coincide with reported solar flares. Quiescent x-ray fluxes with wave lengths  $<20\text{\AA}$  correlate with sun spot numbers and 2800 MC radio flux. Correlating these solar x-ray fluxes with ionospheric disturbances, during periods of high solar activity, provides new information for investigating the ionosphere's environment.

Finally, the neutron and the gamma ray detectors monitor galactic cosmic ray fluxes, providing data on flux modulation due to solar activity.<sup>4,7</sup> Observed modulations are 2 to 4 times greater than the modulations observed from ground-based monitors for the same cosmic ray showers. Due to high satellite altitude, cosmic rays of low as well as high magnetic rigidity are detected.

The results outlined above represent analysis of only a minor portion of Vela Satellite data received to date. The 2 billion bits of telemetered data give some feeling for the magnitude of the LASL task. Further, reduction of present data and collection and correlation of new data should extend knowledge of magnetospheric radiation environments and of the effects of high solar activity on these environments.

A final note of appreciation to scientists at LASL who have done this research and whose words, graphs, and schematics have been so freely used by the Authors.

## REFERENCES

1. The information contained in Part I, History, is a synthesis of numerous contractor reports and Program Office general knowledge. Specific questions should be addressed to Maj Robert C. Axtell, SSD (SSUNE), LAAFS, AFUPO, Los Angeles, California 90045.
2. (U) "Detectors - Logics Systems for Launch 3 - LASL Detector", LASL P-4, 29 Mar 65. (Secret)
3. "Detection of Nuclear Explosions in Space", Los Alamos Scientific Laboratory, Members of Group 4, April 1964. (Unclas)
4. "Vela Satellite Program Progress Report", LASL P-4, 1 Jan 65 (Unclas)
5. S.J. Bame, J.R. Asbridge, H.E. Felthouser, R.A. Olson and I.B. Strong, "Angular Distribution of Particles and Magnetospheric Anisotropy at 17 Earth Radii", LASL, 1964. (Unclas)
6. "Spatial Distribution, Energy Spectra and Time Variations of Energetic Electrons (E750 Kev) at 17.7 Earth Radii", Physical Review Letters, 15 Feb 65. (Unclas)
7. J.P. Conner, W.D. Evans, M.D. Montgomery, S. Singer, and E.E. Stogsdill, "Solar Flare X-ray Emission Measurements" and "Plasma Observations at 10<sup>5</sup> KM", Space Research V. (Unclas)
8. (U) "The Effect of Charged Particle Environments on Military Space Flight", Technical Documentary Report No. SSD-TDR-63-244. Sep 63 (Secret) "The Earth's Magnetosphere", Chapter I (Unclas)
9. J.R. Asbridge, S.J. Bame, H.E. Felthouser, R.A. Olson, and I.B. Strong, LASL, "Streaming of Electrons and Protons in the Earth's Magnetospheric Tail at 17 Earth Radii", Presented AGU 46th Annual Meeting, 22 Apr 65 (Unclas)

**VELA SATELLITE PROGRAM MANAGEMENT**

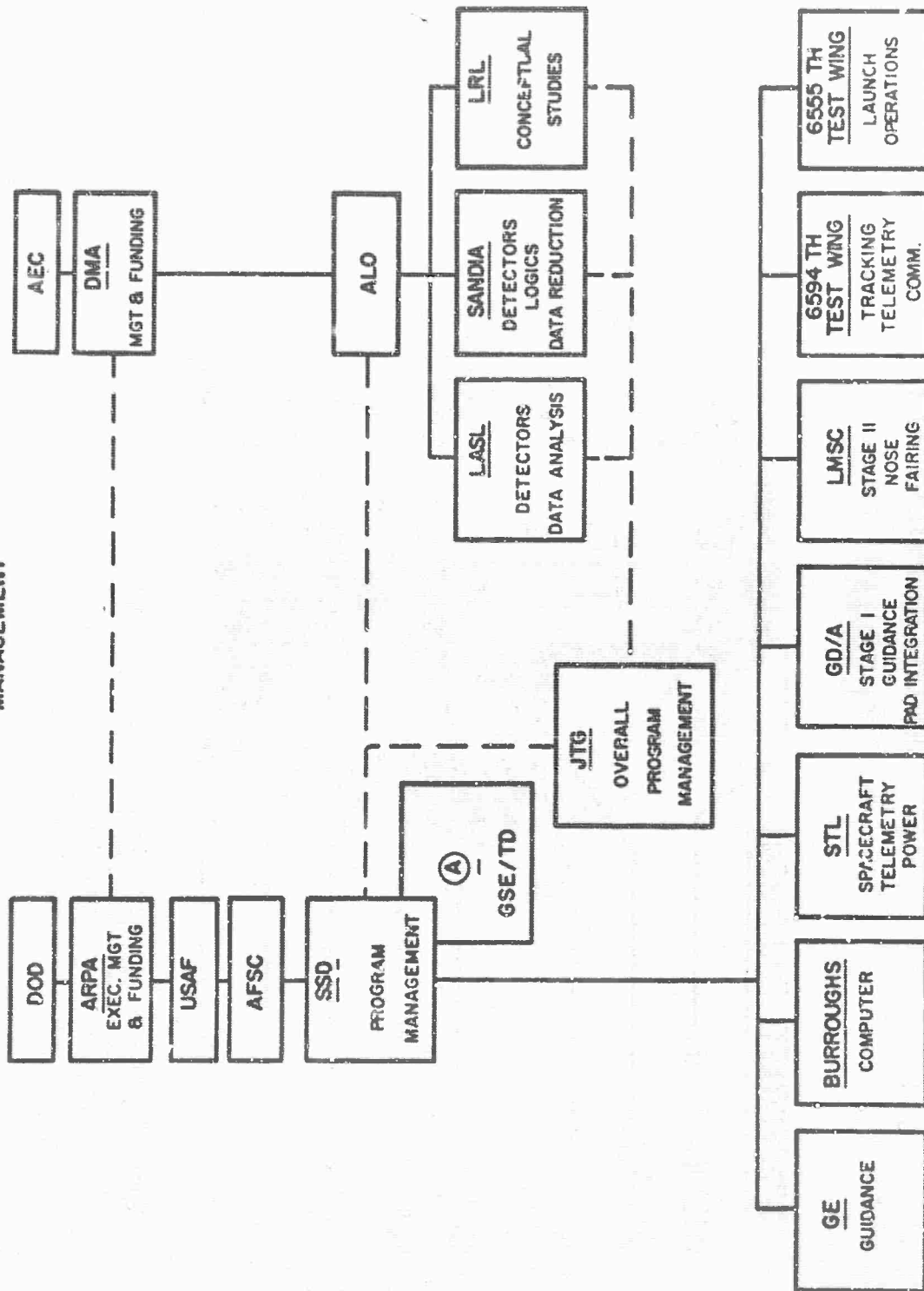

Figure 1

# VELA SPACECRAFT

## CUTAWAY VIEW

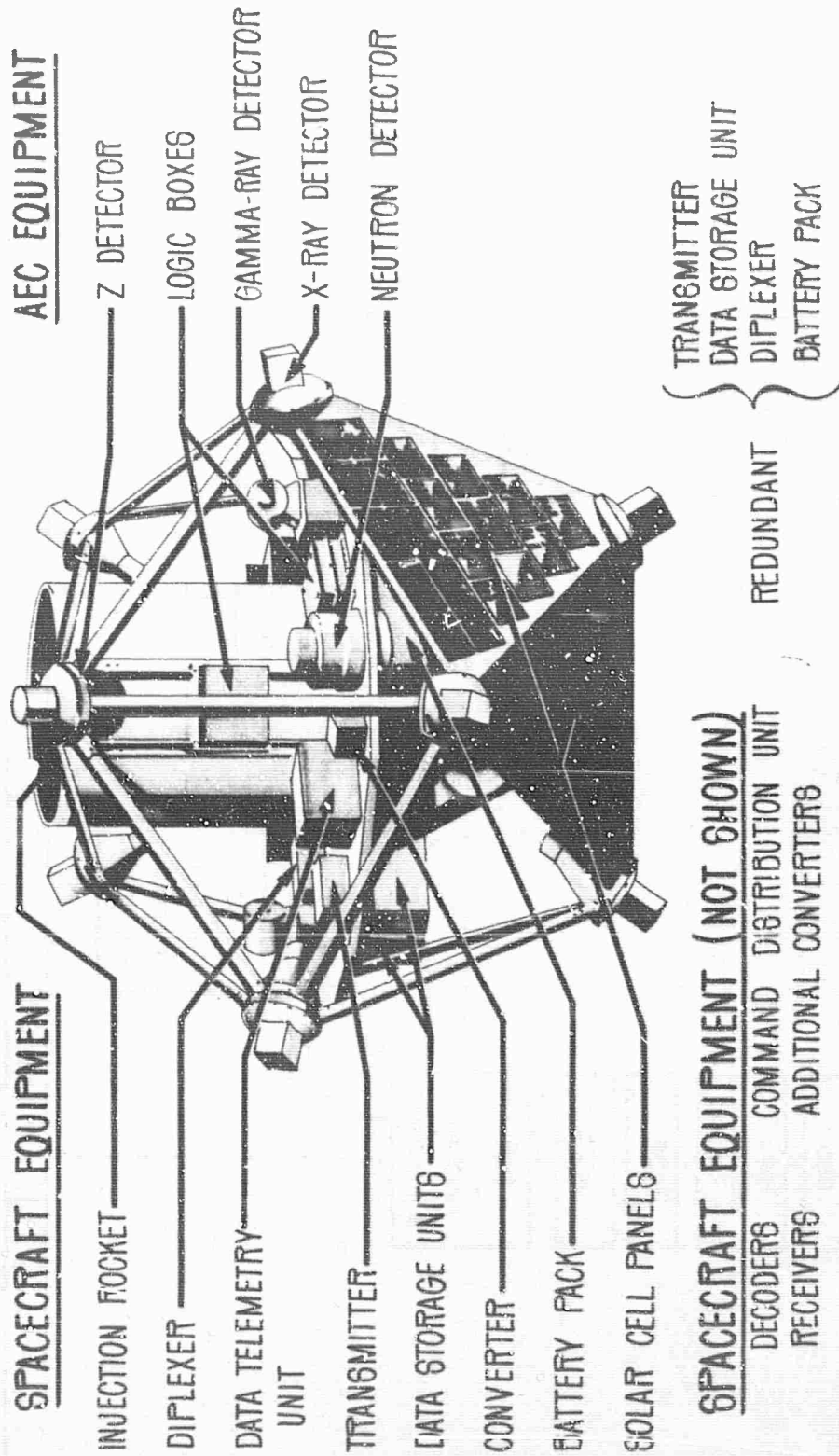
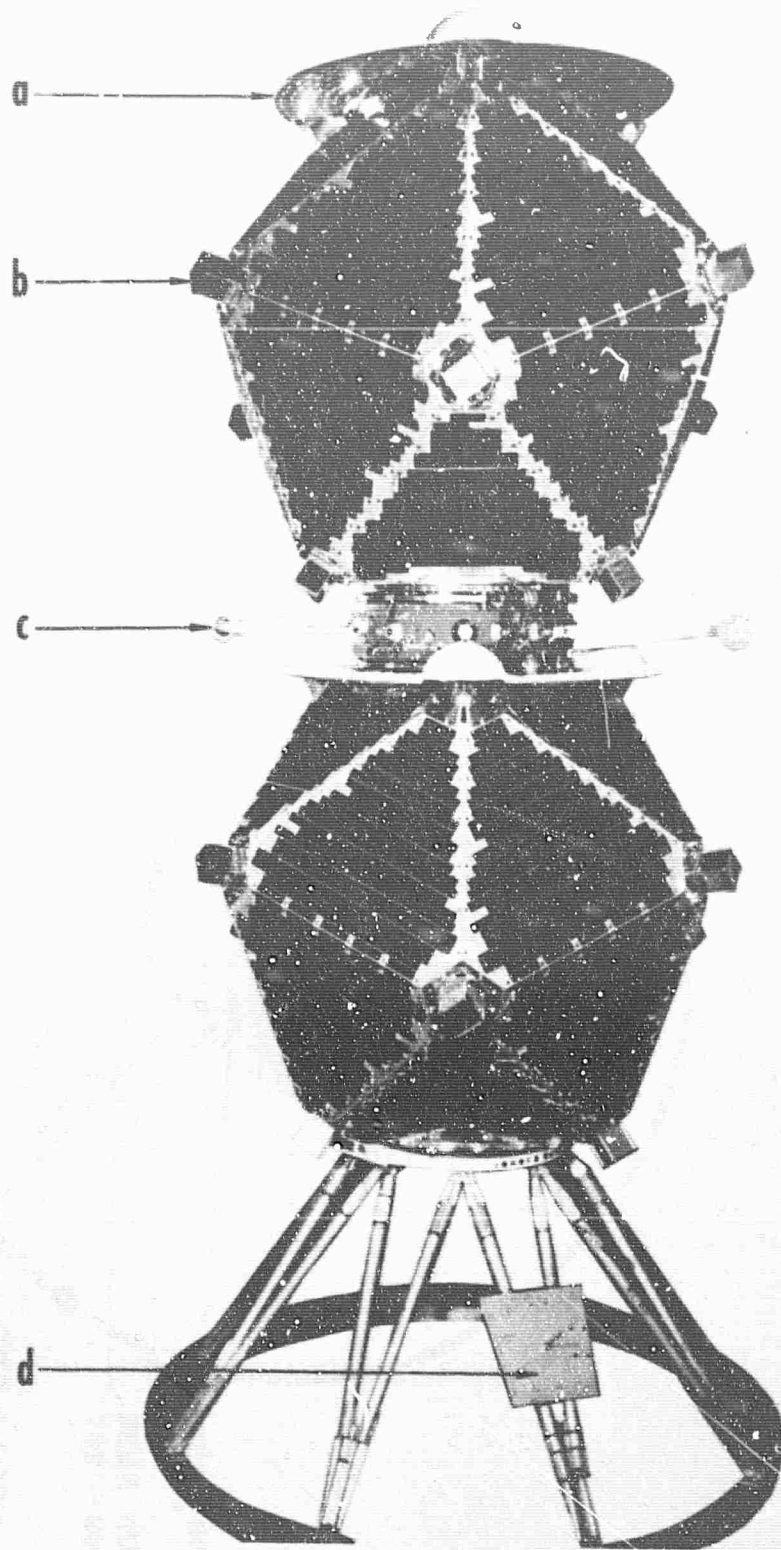

Figure 2



SPACECRAFT TANDEM STACK (a) Heat Shield, (b) X-Ray Detector, (c) Spin-Up Interstage, (d) Transmitter on Truss Structure. Photo courtesy of TRW Inc.

Figure 3

# SEQUENCE OF EVENTS

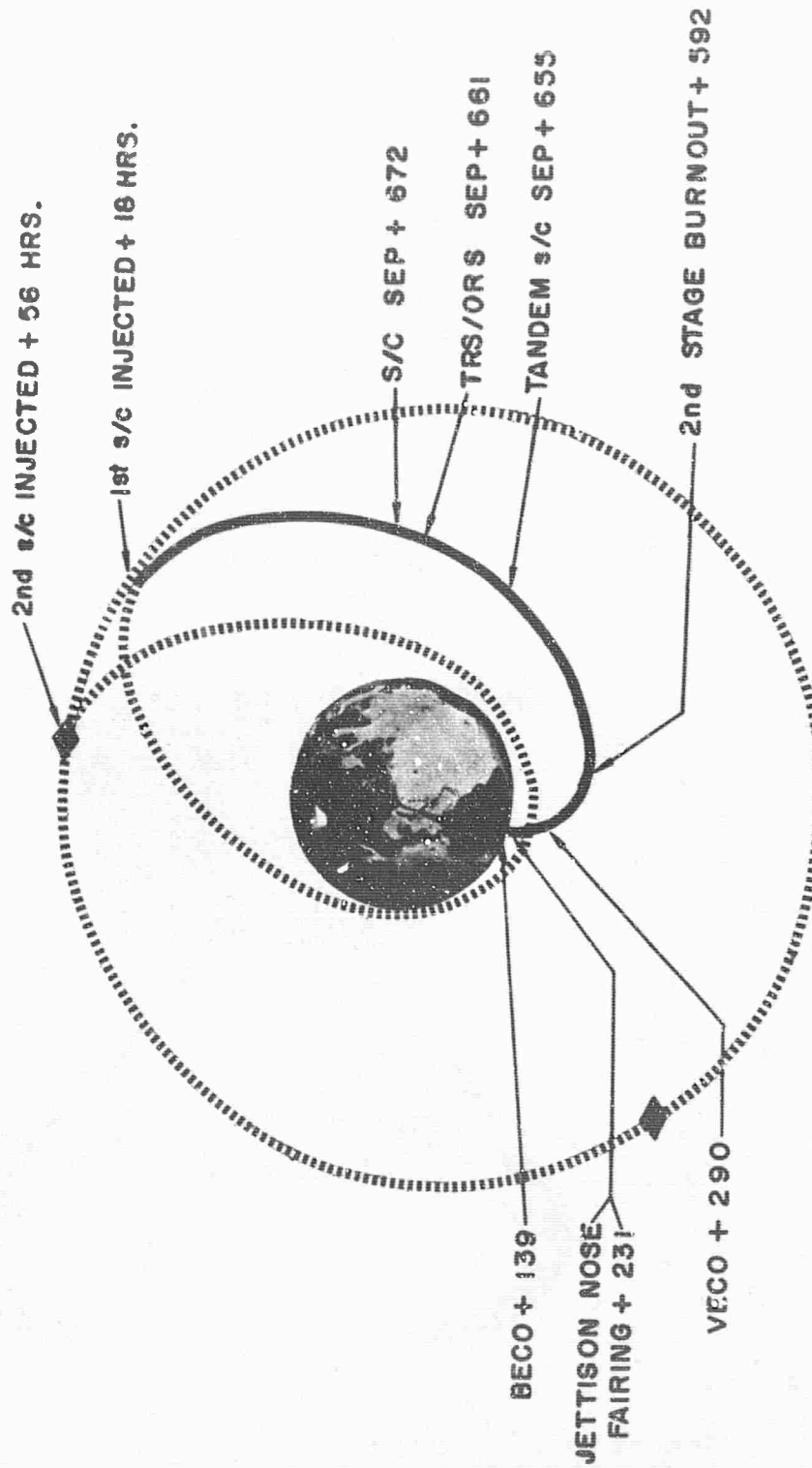

Figure 4

### SPACECRAFT ORBIT PARAMETERS\*

	LAUNCH 1	LAUNCH 2	LAUNCH 3
PERIOD	108 HOURS	100 HOURS	112 HOURS
APOGEE	62,700 N.M.	56,500 N.M.	64,200 N.M.
PERIGEE	55,000 N.M.	51,000 N.M.	56,300 N.M.
ORBIT INCLINATION	40°	37°	35°

\* PARAMETER VALUES ARE NOMINAL. TWO S/C WERE PLACED IN ORBIT EACH LAUNCH. THE TRUE ORBIT PARAMETERS FOR A GIVEN S/C MAY VARY FROM THE NOMINAL VALUES FOR ITS LAUNCH BY  $\pm 4\%$ .

FIGURE 5

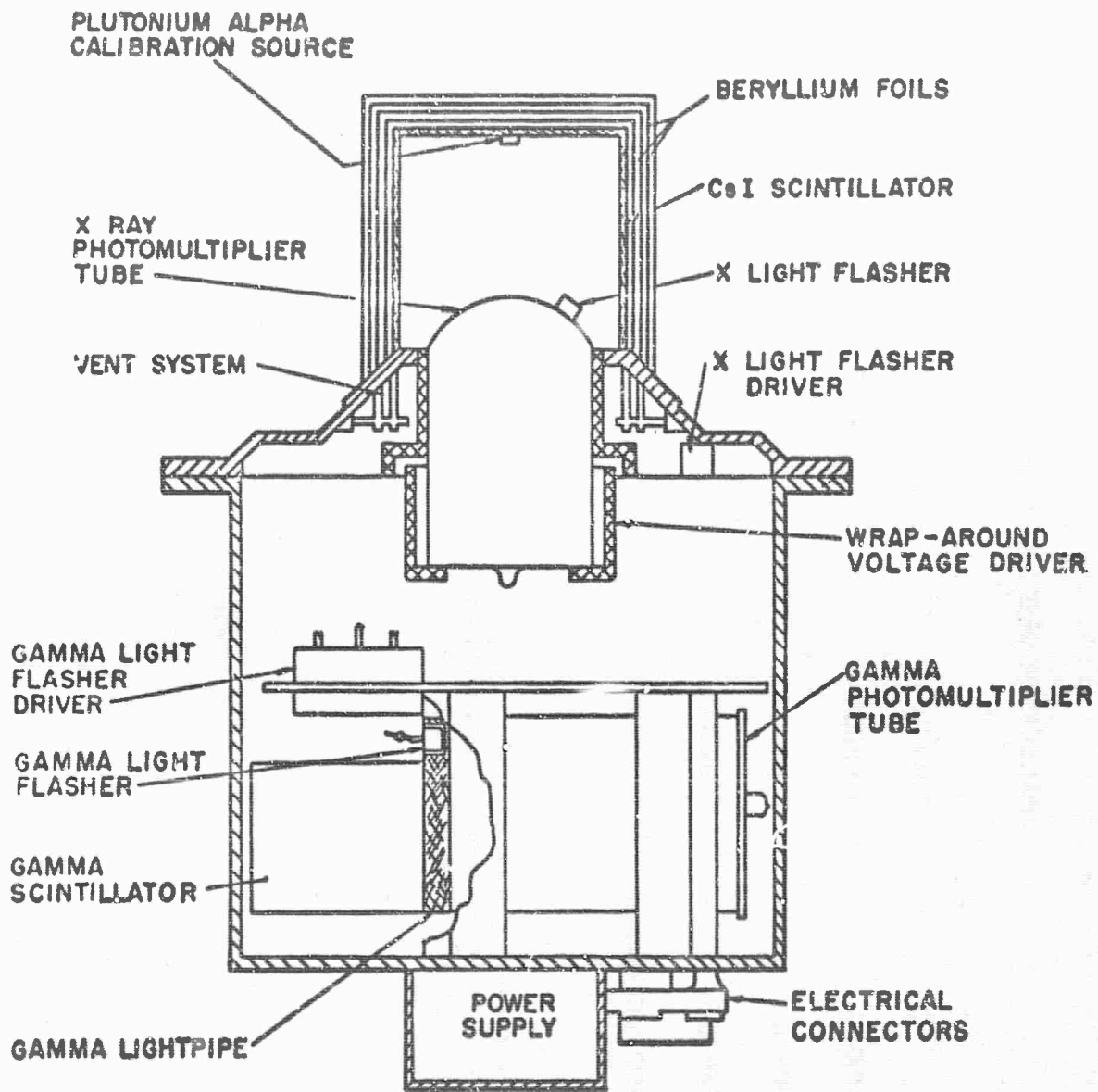

### XG DETECTOR

Figure 6



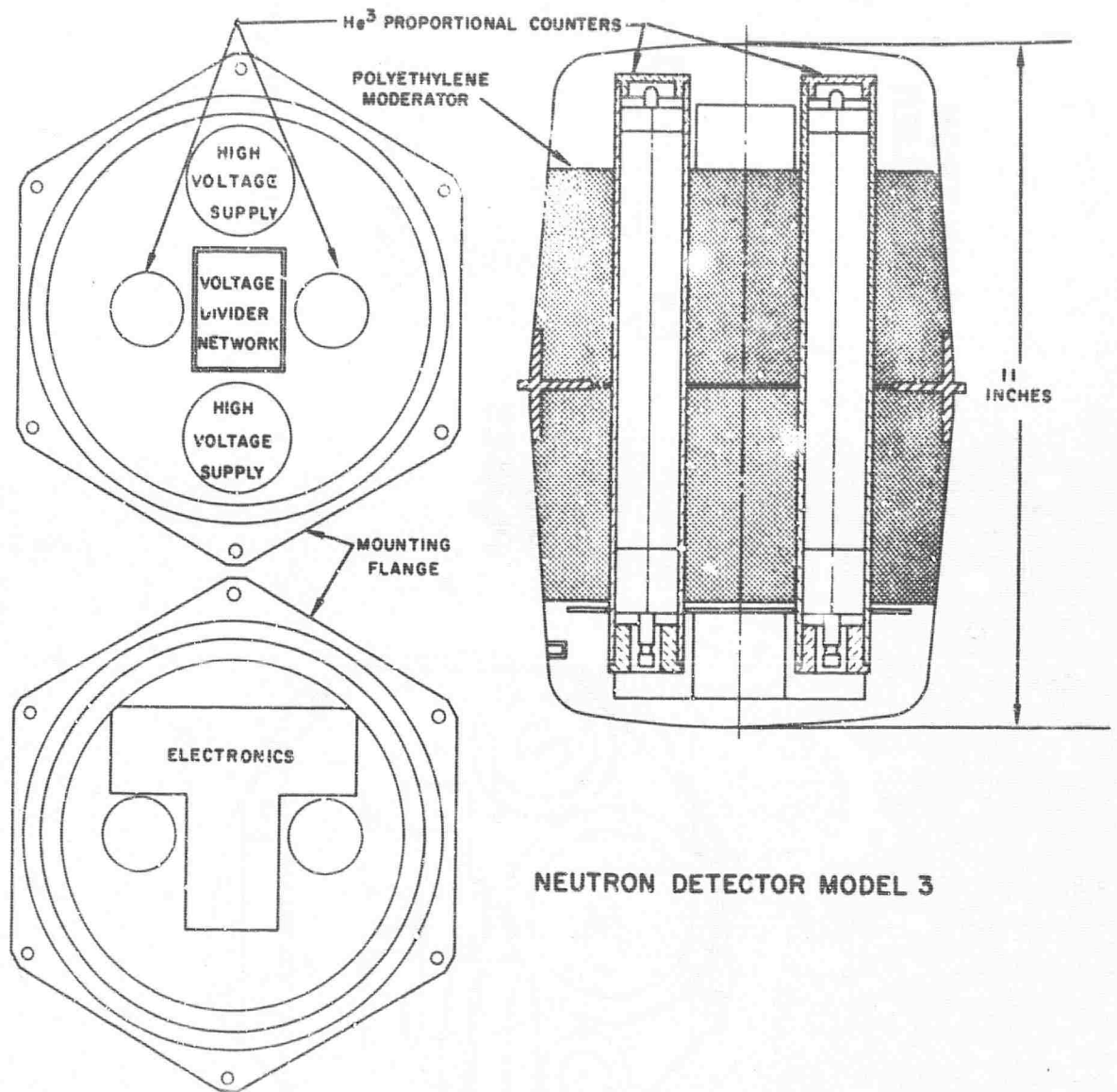

NEUTRON DETECTOR MODEL 3

Figure 7

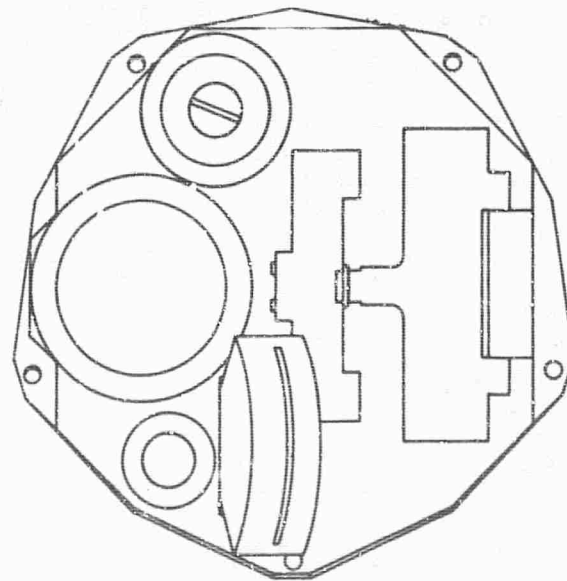
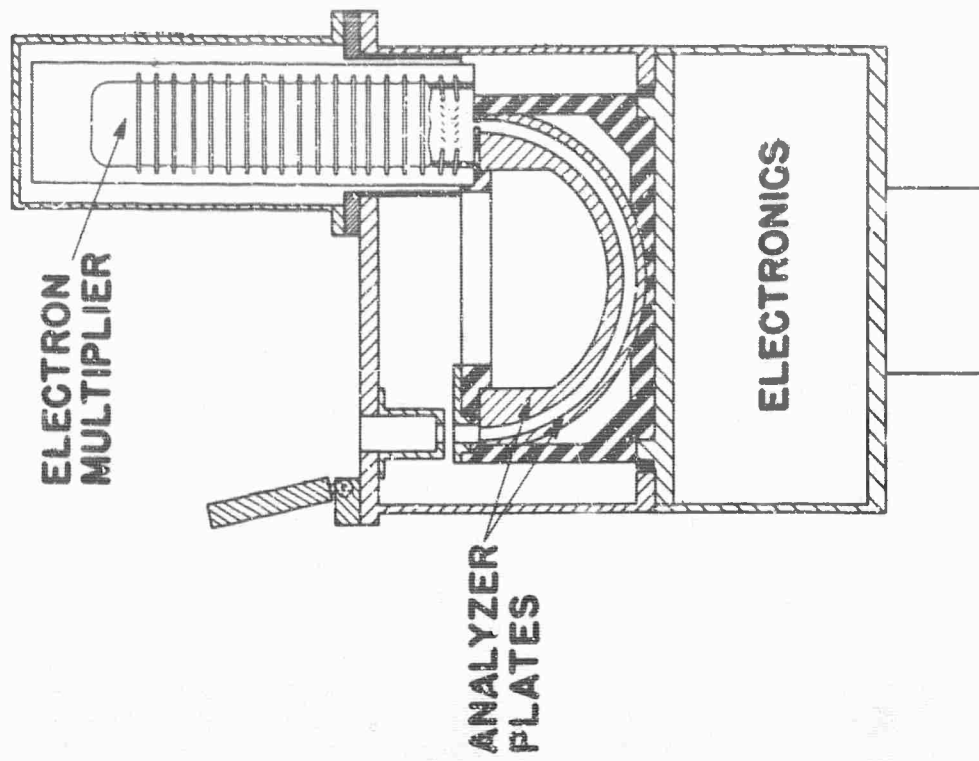

**ELECTRON - PROTON SPECTROMETER**

Figure 8

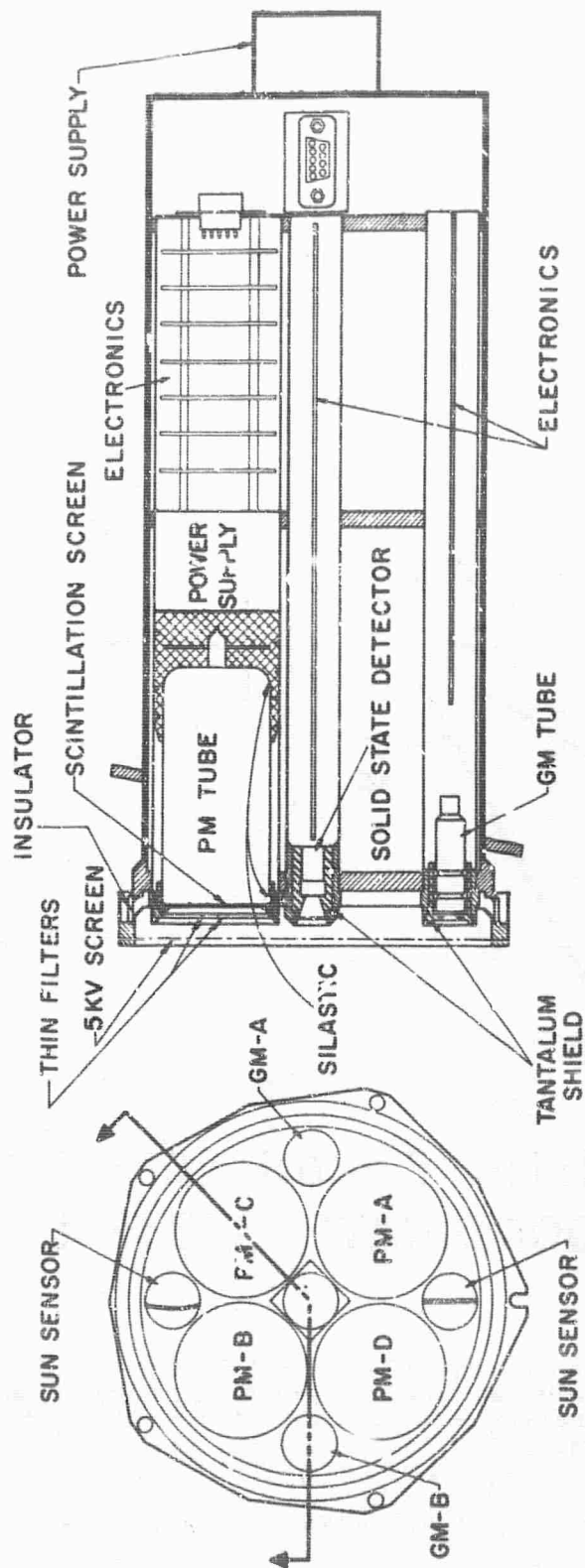

## XV DETECTOR

Figure 9

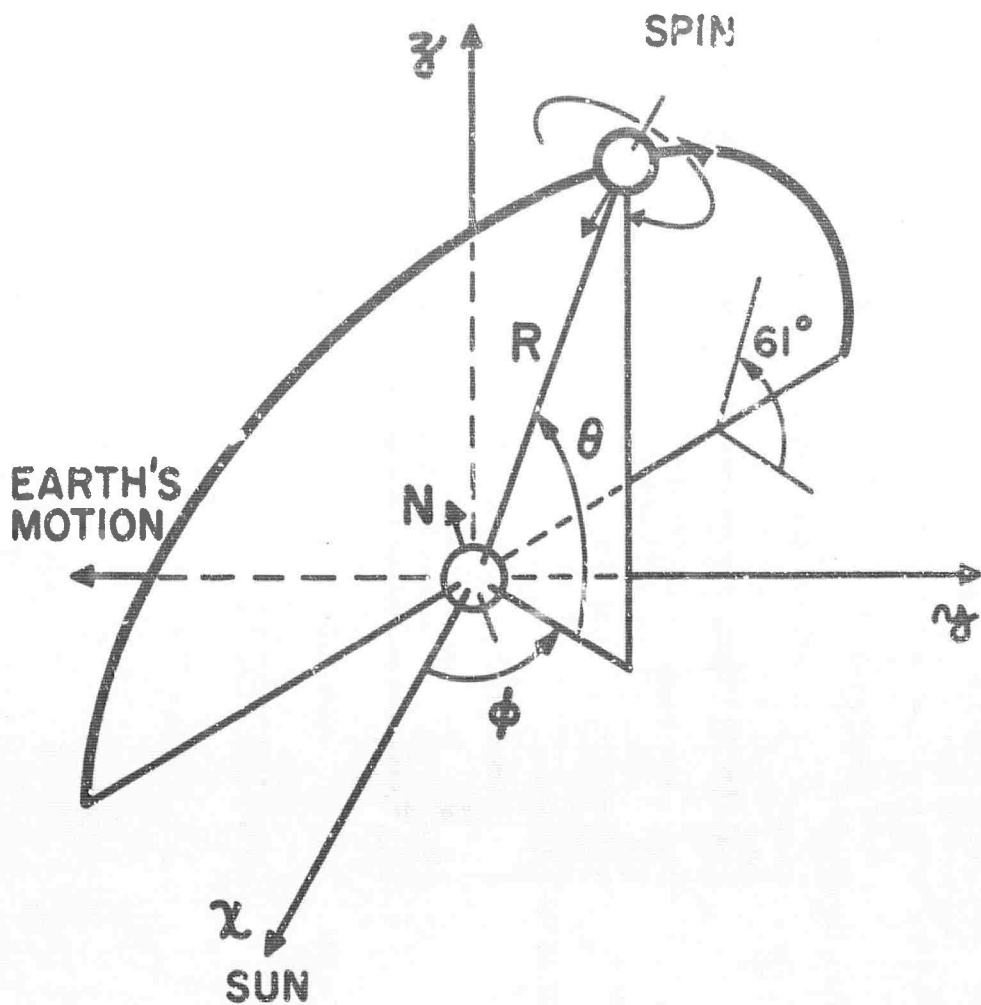

## GEOCENTRIC SOLAR ECLIPTIC COORDINATE SYSTEM

The geocentric coordinate system is centered at the earth's center and has its positive x axis directed toward the sun along the earth-sun line. The satellite position is given in ecliptic longitude  $\phi$ , ecliptic latitude  $\theta$ , and geocentric distance  $R$ .

Figure 10

MAGNETIC FIELD LINES  
DEFORMED BY THE SOLAR  
WIND IN THE PLANE DEFINED  
BY THE EARTH-SUN LINE AND  
THE EARTH'S MAGNETIC AXIS

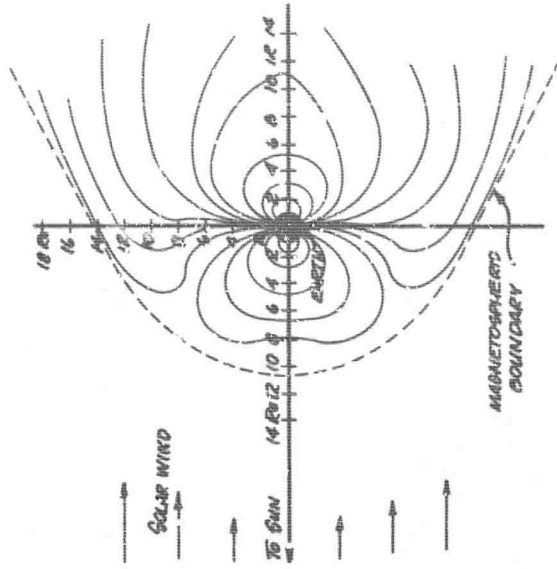

QUANTIFICATION OF STATIONARY CONTOURS OF CONSTANT  
DIRECTIONAL FLUX OF ELECTRONS (E+40KV)  
IN THE MAGNETIC EQUATORIAL PLANE AS  
MEASURED WITH EXPLORES III & III'

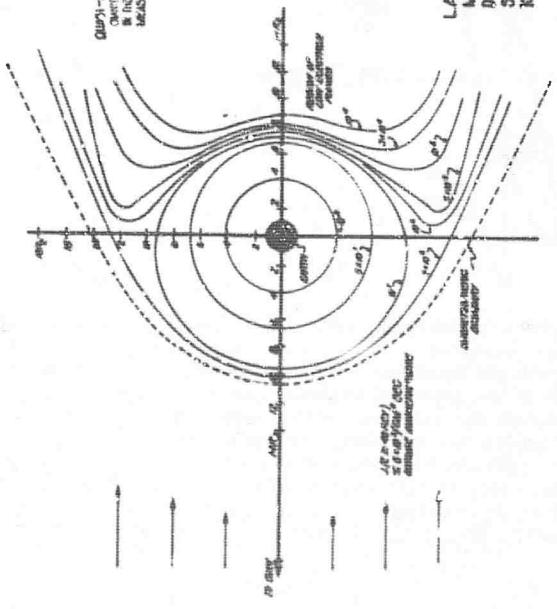

RESULTS OF SPACECRAFT TELEPHONE  
CONFERENCES HELD AT 10:00  
ON JANUARY 20, 1963

L.A. FRANK, E. MACGREGOR AND J. VAN ALLEN  
MARCH 1963  
DEPT. OF PHYSICS  
STATE UNIVERSITY OF IOWA  
IOWA CITY, IOWA

Figure 11

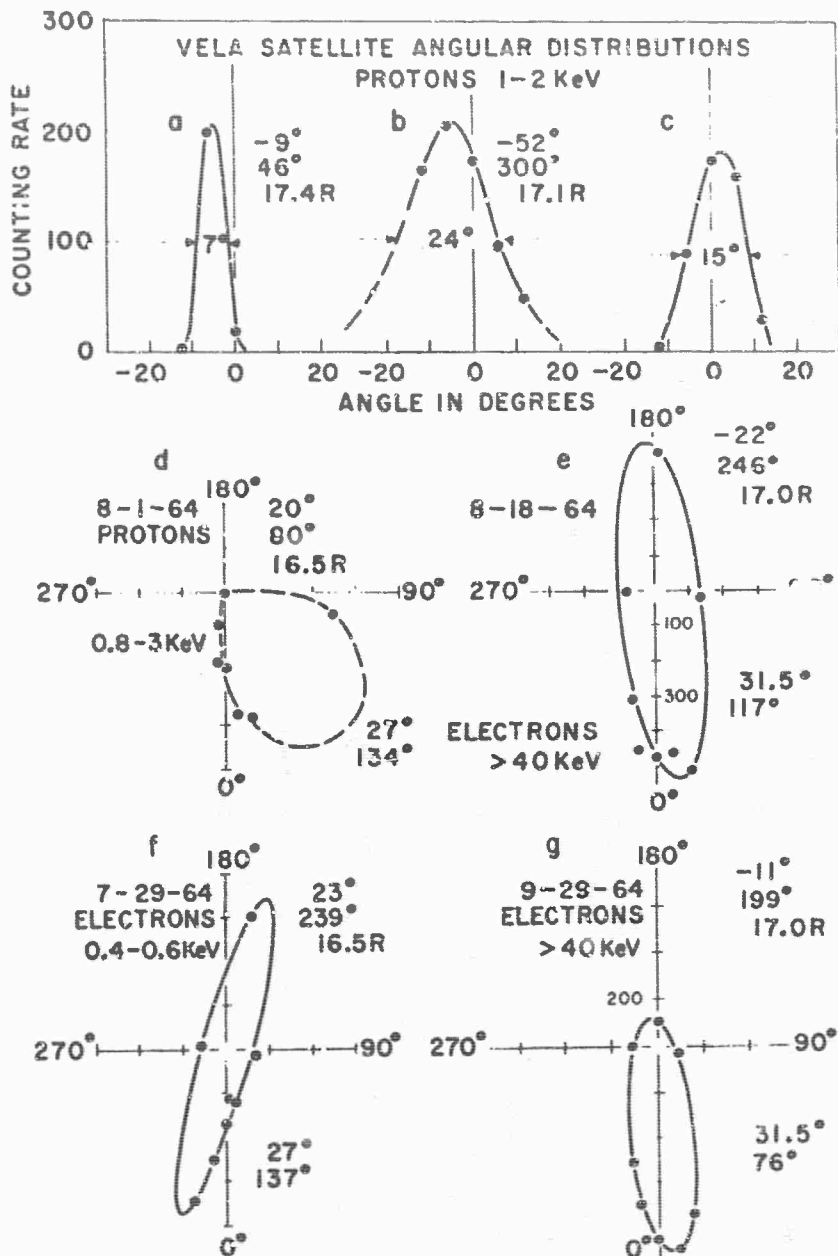

These graphs are charged particle angular distributions measured by the Launch II PK detector. The satellite position in  $\phi$ ,  $\Theta$ , and  $R$  is given in the upper right hand corner of each graph. The lower set of numbers give the tilt of the plane of analysis and the longitude of the projection of the spin axis on the ecliptic. Graphs (a), (b), and (c) depict the narrowest proton distribution, the broadest and an average distribution respectively; (d) shows a skewed distribution--an unusual case; (e) and (g) are polar plots of distributions of energetic electrons; (f) is an example of a non-isotropic distribution of lower energy electrons. The radial scales in (d), (e), (f), and (g) are in counts per second.

Figure 12

SPATIAL DISTRIBUTION OF THE ELECTRON SIGNALS: OCT. 1963 — JULY, 1964  
 SPACECRAFT 1801 (IA) — 1851 (IB) —

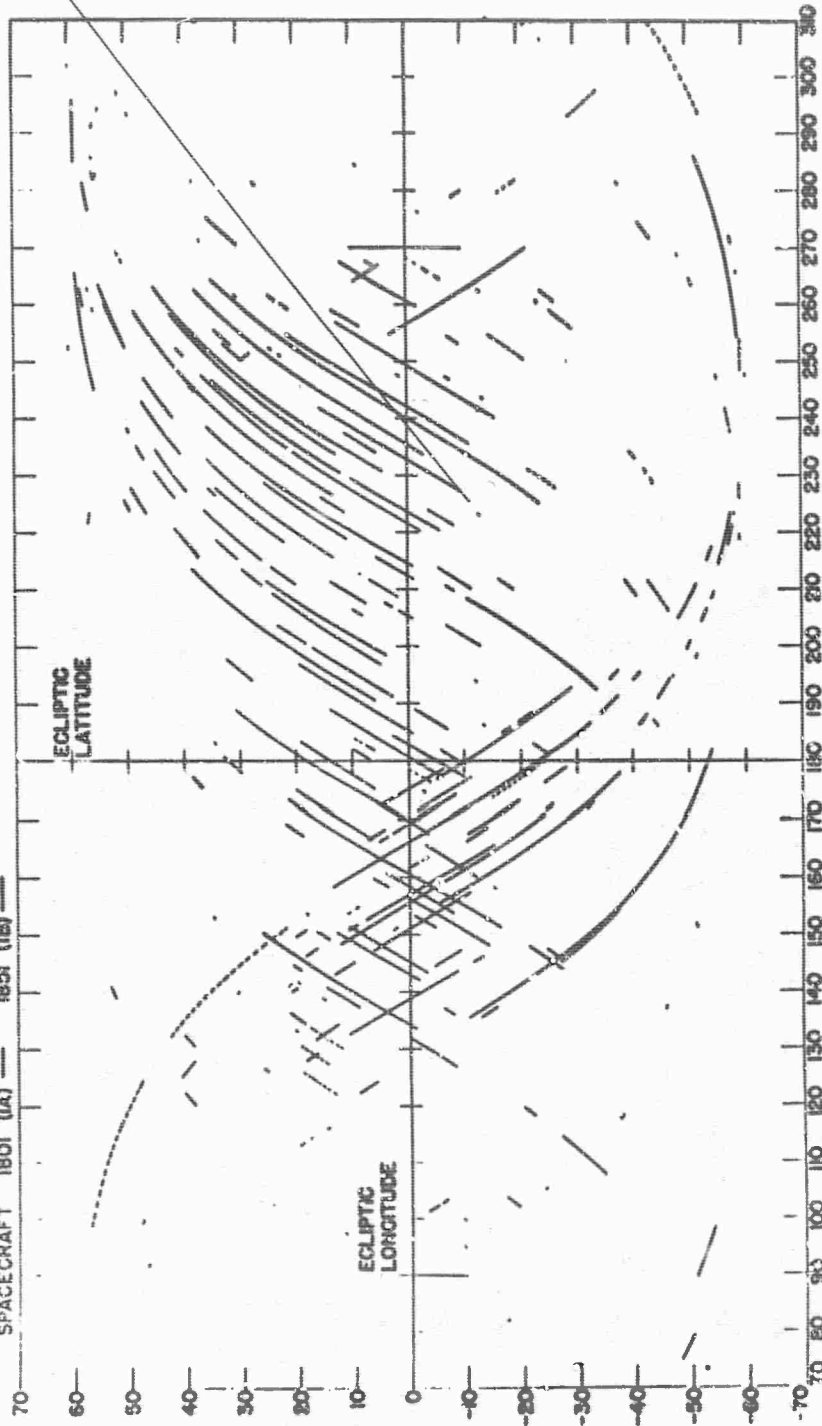

This graph gives spatial distribution of Launch I electron events as measured by x-ray detectors. Solid lines represent those parts of the satellite orbits where electron fluxes are well above detector threshold. Dotted lines are orbit traces where electron flux barely exceeds threshold. Figure 13 is a plot in solar ecliptic coordinates. Figure 14 is a plot in ecliptic-magnetic coordinates and shows grouping of electron populations around the magnetic equatorial plane.

Figure 13

SPATIAL DISTRIBUTION OF ELECTRON SIGNALS: OCT, 1963 -- JULY, 1964

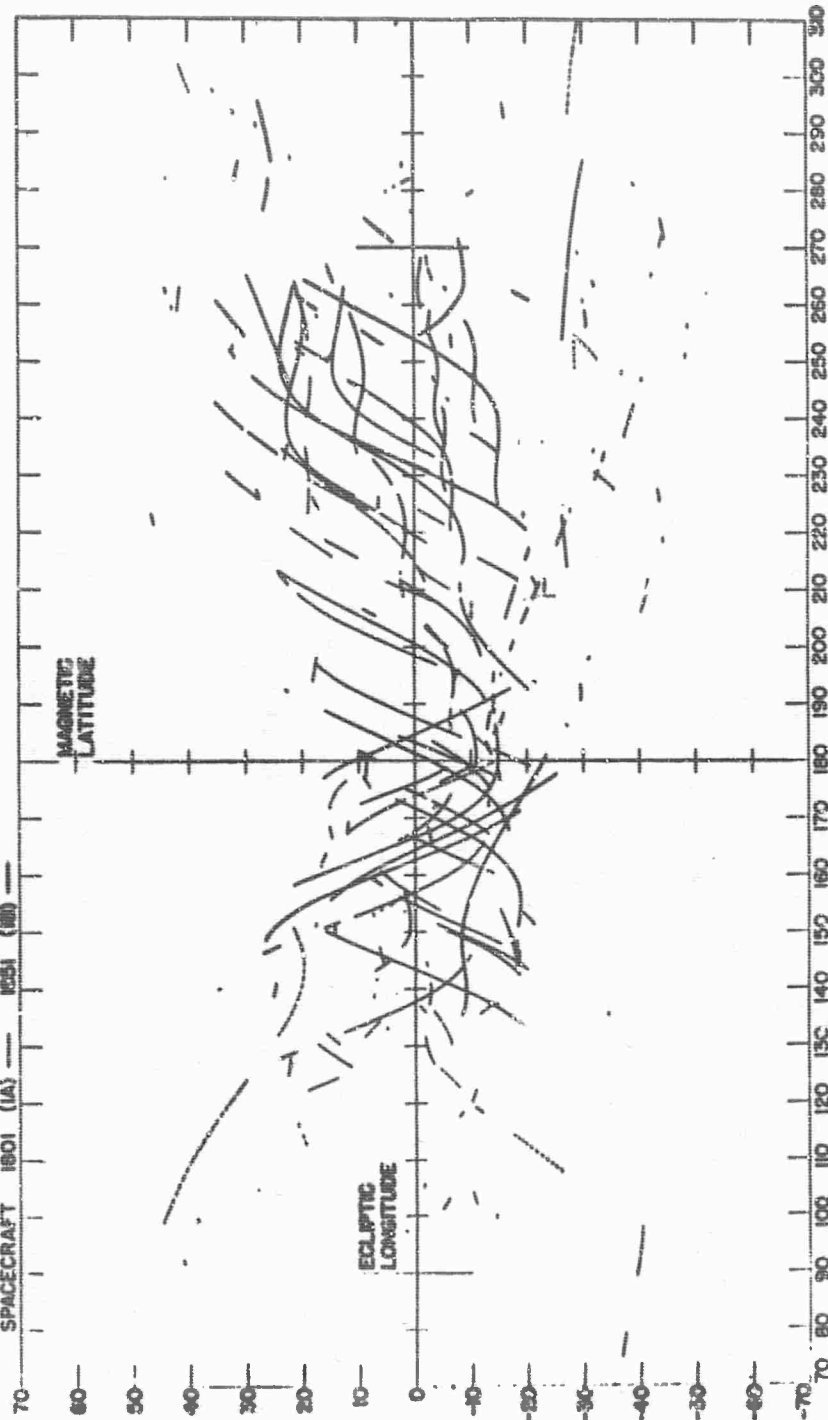

This graph gives spatial distribution of Launch I electron events as measured by x-ray detectors. Solid lines represent those parts of the satellite orbits where electron fluxes are well above detector threshold. Dotted lines are orbit traces where electron flux barely exceeds threshold. Figure 13 is a plot in solar ecliptic coordinates. Figure 14 is a plot in ecliptic-magnetic coordinates and shows grouping of electron populations around the magnetic equatorial plane.

Figure 14



## BIOGRAPHY

Maj Robert C. Axtell, FR30602, received his B.S. in Physics from Principia College, Elsah, Illinois, in 1950. Subsequently, he has completed several graduate courses in Nuclear Engineering from Ohio State University and Air Force Institute of Technology specializing in Research and Engineering. In 1961 he was awarded MBA by the University of Chicago.

In 1952, he was called to active duty taking training in Special Weapons at Sandia Base, Albuquerque, New Mexico.

From 1957 through 1960 he was assigned to the Nuclear Engineering Test Facility at Wright Patterson AFB.

Currently, he is assigned to the Vela Satellite Program as the Payload Project Officer, responsible for radiation detector integration and the ancillary satellite program.

He is a member of the American Geophysical Society and assists in the Vela Satellite Program solar flare warning network.

## BIOGRAPHY

Lt Richard M. Potter, Jr., enlisted in the Air Force in Sep 1960. He was accepted into the Airman Education and Commissioning Program and attended the University of Arizona from Jun 1962 - Jun 1964. He entered OTS Jul 1964 and was commissioned in Sep 64. He began duty on the Vela Satellite Program in Nov 1964. He presently shares responsibility for Vela payload integration and is concerned with space experiments piggyback interfaces.

Lt Potter attended Oberlin College (1957 - 1960) and University of Arizona (1962 - 1964) receiving a B.S. in Mechanical Engineering from University of Arizona with a Nuclear Eng. minor. He is a member of Tau Beta Pi honorary engineering fraternity.

## DOCUMENT CONTROL DATA - R&amp;D

(Security classification of title, body of abstract and indexing annotation must be entered when the overall report is classified)

1. ORIGINATING ACTIVITY (Corporate author) Hq Space Systems Division (SSUNE) Los Angeles Air Force Station Air Force Unit Post Office Los Angeles, California 90045		2a. REPORT SECURITY CLASSIFICATION <b>UNCLASSIFIED</b>	
3. REPORT TITLE  Some Contributions of the Vela Satellite Program in Space Research		2b. GROUP <b>N/A</b>	
4. DESCRIPTIVE NOTES (Type of report and inclusive dates) Technical documentary report. <b>6</b>			
5. AUTHOR(S) (Last name, first name, initial) AXTELL, Robert C. Major, USAF POTTER, Richard M. Lt, USAF			
6. REPORT DATE 15 December 1965	7a. TOTAL NO. OF PAGES 36	7b. NO. OF REFS 9	
8a. CONTRACT OR GRANT NO.	9a. ORIGINATOR'S REPORT NUMBER(S) SSD-TR-65-142		
b. PROJECT NO.	9b. OTHER REPORT NO(S) (Any other numbers that may be assigned this report)		
c.			
d.			
10. AVAILABILITY/LIMITATION NOTICES  Qualified users may obtain copies of this report from DDC.			
11. SUPPLEMENTARY NOTES		12. SPONSORING MILITARY ACTIVITY  Advanced Research Projects Agency	
13. ABSTRACT  The successful launches of the Vela Satellite Program have resulted in increased knowledge of the radiation environments at 17 to 18 Earth radii. Discussed in this paper are Vela Satellite Program management structure, spacecraft and payload description and a summary of the analysis of scientific data obtained from the orbiting satellites. The Vela Satellite Program achieved a space "first" by placing two similar spacecraft into high altitude circular orbits in one launch. Operational support of the satellites has been effected by efficient command and status telemetry systems. Remarkable reliability exhibited by detectors, detector logics, and spacecraft hardware has allowed data collection over an extended period. The Vela Satellites continuously sample radiation in orbits which twice cut the magnetosphere boundary. Besides confirming general features of the solar wind already observed, the satellites have supplied useful data on the following: the angular and spatial distribution of charged particles in the transition region near the magnetosphere, particle fluxes within the magnetospheric cavity, correlation of solar x-ray activity with reported solar flares, cosmic ray intensity fluctuation.			

14	KEY WORDS	LINK A		LINK B		LINK C	
		ROLE	WT	ROLE	WT	ROLE	WT
Vela Satellite Program (Nuclear Test Detection), Space Research, Magnetosphere, Space Radiation Environment, R&D Management, Satellite, Nuclear Detection, Solar X-rays, Solar Winds, Solar Flare, Spin-Stabilization, Vela Management, Neutron Detectors, X-ray Detectors, Gamma Ray Detectors, Proton-Electron Spectrometer							

**INSTRUCTIONS**

1. **ORIGINATING ACTIVITY:** Enter the name and address of the contractor, subcontractor, grantee, Department of Defense activity or other organization (*corporate author*) issuing the report.
- 2a. **REPORT SECURITY CLASSIFICATION:** Enter the overall security classification of the report. Indicate whether "Restricted Data" is included. Marking is to be in accordance with appropriate security regulations.
- 2b. **GROUP:** Automatic downgrading is specified in DoD Directive 5200.10 and Armed Forces Industrial Manual. Enter the group number. Also, when applicable, show that optional markings have been used for Group 3 and Group 4 as authorized.
3. **REPORT TITLE:** Enter the complete report title in all capital letters. Titles in all cases should be unclassified. If a meaningful title cannot be selected without classification, show title classification in all capitals in parenthesis immediately following the title.
4. **DESCRIPTIVE NOTES:** If appropriate, enter the type of report, e.g., interim, progress, summary, annual, or final. Give the inclusive dates when a specific reporting period is covered.
5. **AUTHOR(S):** Enter the name(s) of author(s) as shown on or in the report. Enter last name, first name, middle initial. If military, show rank and branch of service. The name of the principal author is an absolute minimum requirement.
6. **REPORT DATE:** Enter the date of the report as day, month, year; or month, year. If more than one date appears on the report, use date of publication.
- 7a. **TOTAL NUMBER OF PAGES:** The total page count should follow normal pagination procedures, i.e., enter the number of pages containing information.
- 7b. **NUMBER OF REFERENCES:** Enter the total number of references cited in the report.
- 8a. **CONTRACT OR GRANT NUMBER:** If appropriate, enter the applicable number of the contract or grant under which the report was written.
- 8b, 8c, & 8d. **PROJECT NUMBER:** Enter the appropriate military department identification, such as project number, subproject number, system numbers, task number, etc.
- 9a. **ORIGINATOR'S REPORT NUMBER(S):** Enter the official report number by which the document will be identified and controlled by the originating activity. This number must be unique to this report.
- 9b. **OTHER REPORT NUMBER(S):** If the report has been assigned any other report numbers (*either by the originator or by the sponsor*), also enter this number(s).
10. **AVAILABILITY/LIMITATION NOTICES:** Enter any limitations on further dissemination of the report, other than those

imposed by security classification, using standard statements such as:

- (1) "Qualified requesters may obtain copies of this report from DDC."
- (2) "Foreign announcement and dissemination of this report by DDC is not authorized."
- (3) "U. S. Government agencies may obtain copies of this report directly from DDC. Other qualified DDC users shall request through \_\_\_\_\_."
- (4) "U. S. military agencies may obtain copies of this report directly from DDC. Other qualified users shall request through \_\_\_\_\_."
- (5) "All distribution of this report is controlled. Qualified DDC users shall request through \_\_\_\_\_."

If the report has been furnished to the Office of Technical Services, Department of Commerce, for sale to the public, indicate this fact and enter the price, if known.

11. **SUPPLEMENTARY NOTES:** Use for additional explanatory notes.
12. **SPONSORING MILITARY ACTIVITY:** Enter the name of the departmental project office or laboratory sponsoring (*paying for*) the research and development. Include address.
13. **ABSTRACT:** Enter an abstract giving a brief and factual summary of the document indicative of the report, even though it may also appear elsewhere in the body of the technical report. If additional space is required, a continuation sheet shall be attached.

It is highly desirable that the abstract of classified reports be unclassified. Each paragraph of the abstract shall end with an indication of the military security classification of the information in the paragraph, represented as (TS), (S), (C), or (U).

There is no limitation on the length of the abstract. However, the suggested length is from 150 to 225 words.

14. **KEY WORDS:** Key words are technically meaningful terms or short phrases that characterize a report and may be used as index entries for cataloging the report. Key words must be selected so that no security classification is required. Identifiers, such as equipment model designation, trade name, military project code name, geographic location, may be used as key words but will be followed by an indication of technical context. The assignment of links, roles, and weights is optional.