

@ 1



# THE EFFECTS OF FLOW THROUGH AN AIRCRAFT PITOT-STATIC PROBE AT SUPERSONIC MACH NUMBERS

This document has been approved for public release  
its distribution is unlimited. *Per TAB 73-6  
dtd 15 March 1973*

A. L. Baer  
ARO, Inc.

PROPERTY OF U S AIR FORCE  
AEDC LIBRARY  
AF 40(600)1200

February 1966

~~Each transmittal of this document outside the Department of Defense must have prior approval of AEDC/CEHCE~~

*per AF letter, 12 Jan 70, signed William E. Cole*

~~This document is subject to special export controls and each transmittal to foreign governments or foreign nationals may be made only with prior approval of AEDC/CEHCE (EDCL). FDO-1/STINGO, WP AFBoles~~

**VON KÁRMÁN GAS DYNAMICS FACILITY  
ARNOLD ENGINEERING DEVELOPMENT CENTER  
AIR FORCE SYSTEMS COMMAND  
ARNOLD AIR FORCE STATION, TENNESSEE**

AEDC TECHNICAL LIBRARY



0422 12000 2340  
5 0720 00031 2340

# *NOTICES*

When U. S. Government drawings, specifications, or other data are used for any purpose other than a definitely related Government procurement operation, the Government thereby incurs no responsibility nor any obligation whatsoever, and the fact that the Government may have formulated, furnished, or in any way supplied the said drawings, specifications, or other data, is not to be regarded by implication or otherwise, or in any manner licensing the holder or any other person or corporation, or conveying any rights or permission to manufacture, use, or sell any patented invention that may in any way be related thereto.

Qualified users may obtain copies of this report from the Defense Documentation Center.

References to named commercial products in this report are not to be considered in any sense as an endorsement of the product by the United States Air Force or the Government.

## ERRATA

AEDC-TR-66-28, February 1966

THE EFFECTS OF FLOW THROUGH  
AN AIRCRAFT PITOT-STATIC PROBE  
AT SUPERSONIC MACH NUMBERS

A. L. Baer, ARO, Inc.

Arnold Engineering Development Center  
Air Force Systems Command  
Arnold Air Force Station, Tennessee

The figure on the reverse side replaces Fig. 4a  
on page 9 of AEDC-TR-66-28.

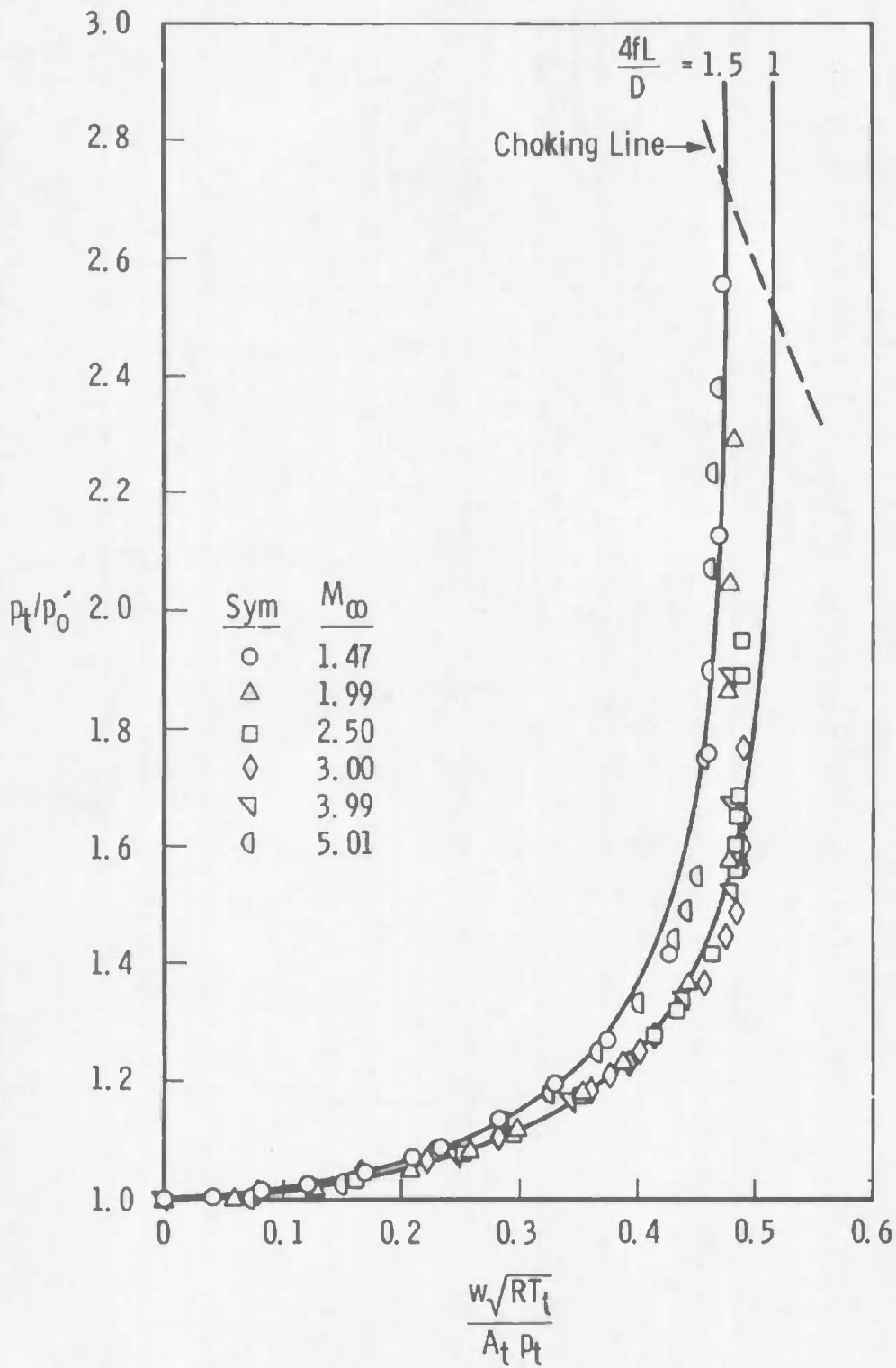

a. Pitot Duct

Fig. 4. The Effects of Flow Injected into the Probe

THE EFFECTS OF FLOW THROUGH AN AIRCRAFT  
PITOT-STATIC PROBE  
AT SUPERSONIC MACH NUMBERS

This document has been approved for public release  
its distribution is unlimited. *per TAB 73-61, 1973*  
*dtd 15 March, 1973*

A. L. Baer  
ARO, Inc.

~~Each transmittal of this document outside the Department of Defense must have prior approval of AFFDL (FDCI)~~

*per AF letter 12 Jan 73 signed William Q. Gale*

This document is subject to special export controls and each transmittal to foreign governments or foreign nationals may be made only with prior approval of AFFDL (FDCI). *FDO-3/STINFO, W-PR-1, Ohio*

## FOREWORD

The work reported herein was done at the request of the Air Force Flight Dynamics Laboratory (AFFDL) (FDCL), Air Force Systems Command (AFSC), under Program Element 62405364, Project 8222, Task 822207. The Bendix Corporation, Research Laboratories Division, acted as a consultant to the sponsoring agency.

The results of tests presented were obtained by ARO, Inc. (a subsidiary of Sverdrup and Parcel, Inc.), contract operator of the Arnold Engineering Development Center (AEDC), AFSC, Arnold Air Force Station, Tennessee, under Contract AF40(600)-1200. The test was conducted from November 4 through 22, 1965, under ARO Project No. VD0613, and the manuscript was submitted for publication on January 13, 1966.

This technical report has been reviewed and is approved.

Darreld K. Calkins  
Major, USAF  
AF Representative, VKF  
DCS/Test

Jean A. Jack  
Colonel, USAF  
DCS/Test

**ABSTRACT**

Tests of a standard, aircraft-type, pitot-static probe were conducted in the 12-in. supersonic tunnel of the von Kármán Gas Dynamics Facility to evaluate the effects on the probe total and static pressures resulting from drawing flow from the tube or putting flow into the tube. The data were obtained with the probe at zero angle of attack in a supersonic stream at Mach numbers from 1.5 to 5, and the Reynolds number per inch ranged from  $0.12 \times 10^6$  to  $0.58 \times 10^6$ . The results are presented in terms of the ratio of measured probe pressure to the pressure for no tube flow as a function of a nondimensional parameter representing the quantity of flow being passed through the tube.

## CONTENTS

	<u>Page</u>
ABSTRACT . . . . .	iii
NOMENCLATURE . . . . .	vi
I. INTRODUCTION . . . . .	1
II. APPARATUS	
2.1 Wind Tunnel . . . . .	1
2.2 Model . . . . .	1
2.3 Instrumentation and Techniques . . . . .	2
III. TEST PROCEDURE . . . . .	2
IV. RESULTS AND DISCUSSION . . . . .	3
REFERENCES. . . . .	4

## ILLUSTRATIONS

Figure

1. Probe Geometry (Rosemount Engineering Company Type TRU-1/A) . . . . .	5
2. Diagram of Test Equipment Installation . . . . .	6
3. The Effects of Flow Drawn through the Probe	
a. Pitot Duct . . . . .	7
b. Static Ports . . . . .	8
4. The Effects of Flow Injected into the Probe	
a. Pitot Duct . . . . .	9
b. Static Ports . . . . .	10
5. Schlieren Photographs for Ejecting Flow through the Probe Tubes; $M_\infty = 1.99$	
a. Pitot Duct . . . . .	11
b. Static Ports . . . . .	11

## TABLE

I. Test Conditions . . . . .	12
------------------------------	----



NOMENCLATURE

$A_s$	Area of the four static pressure orifices, 0.01227 in. <sup>2</sup>
$A_t$	Area of the total pressure port, 0.02761 in. <sup>2</sup>
$M_\infty$	Free-stream Mach number
$p_o$	Tunnel stilling chamber pressure, psia
$p_o'$	Stagnation pressure behind normal shock, psia
$p_s$	Probe static pressure for flow in the static tube, psia
$p_t$	Probe pitot pressure for flow in the pitot tube, psia
$p_\infty$	Free-stream static pressure, psia
$R$	Gas constant, $1716.48 \frac{\text{ft}^2}{\text{sec}^2 \text{ } ^\circ\text{R}}$
$Re$	Reynolds number
$T_o$	Tunnel stilling chamber temperature, $^\circ\text{R}$
$T_s$	Total temperature of flow in probe static pressure line, $^\circ\text{R}$
$T_t$	Total temperature of flow in probe total-head line, $^\circ\text{R}$
$w$	Mass rate of flow through probe pitot or static pressure lines, slugs/sec
$\frac{4fL}{D}$	Friction parameter for flow in constant area ducts as defined in Ref. 3 where: $f$ = coefficient of friction $L$ = duct length $D$ = hydraulic diameter

## SECTION I INTRODUCTION

An experimental investigation directed toward studying the feasibility of a fluid state air data computer which would require air flow through the data probe was conducted in the 12-in. supersonic tunnel (Gas Dynamic Wind Tunnel, Supersonic (D)). A conventional, aircraft-type, pitot-static probe was chosen for the investigations, and the objective of the test program was to determine how the indicated probe total and static pressures would change as various flow rates through the probe ducts were maintained by throttling the flow to an external vacuum or from a high pressure air source.

Pressure and flow rate measurements were obtained at Mach numbers of 1.5, 2, 2.5, 3, 4, and 5 with the probe aligned at zero angle of attack. At a given Mach number, tunnel stilling chamber conditions were held constant as the flow through the probe was varied.

## SECTION II APPARATUS

### 2.1 WIND TUNNEL

Tunnel D is an intermittent, variable density wind tunnel with a manually adjusted, flexible-plate-type nozzle and a 12- by 12-in. test section. The tunnel operates at Mach numbers from 1.5 to 5 at stagnation pressures from about 5 to 60 psia and at stagnation temperatures up to about 80°F. A description of the tunnel and airflow calibration information may be found in Refs. 1 and 2.

### 2.2 MODEL

A sketch of the pitot-static probe used during these tests is presented in Fig. 1. The probe was furnished by AFFDL and is identified by the manufacturer (Rosemount Engineering Company) as Type TRU-1/A, Model 850. The pitot tube of the probe was modified by extending the 0.1875-in. -diam bore through a baffle plate which was located within the duct approximately 1.25 in. aft of the probe tip.

A line diagram of the test equipment and installation assembly is shown in Fig. 2. The probe was offset laterally from tunnel centerline to allow the instrument lines to clear the sector hub. All joints along the

instrument lines, with the exception of the "tee" flare fittings (at Section ②) and the unions, were soldered to provide a smooth inside wall. The flowmeter was provided by the Bendix Corporation and was a commercially available instrument calibrated, at atmospheric conditions, for a maximum flow rate of 10 standard cubic feet per minute at a differential pressure of 10.43 in. of water. Two needle valves were installed in parallel between the flowmeter and the vacuum or high pressure air source. The larger valve had a 0.3125-in. -diam orifice and the smaller valve, which was used to make fine adjustments to the flow rate, had a 0.0625-in. -diam orifice.

### 2.3 INSTRUMENTATION AND TECHNIQUES

The instrument lines from the probe pitot and static ports were connected to 15-psid transducers immediately outside the tunnel wall. The transducers were referenced to either a vacuum or atmospheric pressure and were calibrated for ranges of 15, 5, and 1 psia. The pressure measurements are considered accurate to within  $\pm 0.2$  percent of the range being used, and the atmospheric reference pressure was measured to within  $\pm 0.03$  psia.

The flowmeter differential pressure was recorded with an oil U-tube micromanometer, and a flow rate was determined from calibration data which was furnished by the flowmeter manufacturer. Since the meter was calibrated at standard atmospheric conditions, meter outlet pressure and temperature were recorded to correct the indicated flow rate. The pressure measuring instrumentation for the flowmeter was similar to that described above, and the temperature measurement was made by a copper-constantan thermocouple installed within the flow line just beyond the meter exit.

## SECTION III TEST PROCEDURE

At each Mach number, probe pitot and static pressures were measured for the no-flow condition and, subsequently, various probe pressure ratios ( $p_t/p_o'$  or  $p_s/p_\infty$ ) were established by throttling the flow through the control valves until a desired probe pressure ( $p_t$  or  $p_s$ ) was obtained. This procedure was repeated until the flow rate reached a maximum value or until the maximum flowmeter differential pressure was reached.

The nominal tunnel operating conditions at which the data were obtained are given in Table I.

#### SECTION IV RESULTS AND DISCUSSION

The test results for drawing flow through the pitot and static ports of the probe are given in Fig. 3, and the results obtained for ejecting flow through the probe tubes (blowing) are given in Fig. 4. The measured probe pressures ( $p_t$  and  $p_s$ ) have been ratioed to the appropriate value for no tube flow ( $p_o'$  for the pitot and  $p_\infty$  for the static ports) and presented as a function of a nondimensional tube flow parameter. Presented in this form, the data may be viewed from the point of simple duct flow since in the suction tests the pressures  $p_o'$  and  $p_\infty$  can be considered as constant supply pressures and the measured pressures ( $p_t$  and  $p_s$ ) as duct back pressure. For the blowing case, this illustration is reversed and the ducts exhaust to constant back pressures ( $p_o'$  and  $p_\infty$ ).

The results presented in Figs. 3a and 4a show that the pitot tube data follow trends classically portrayed for simple, one-dimensional flow in constant area ducts with friction (after Shapiro, Ref. 3). The curves for various values of the friction parameter,  $4fL/D$ , included in Figs. 3a and 4a are for constant-area duct flow, and although the test setup included a change in tube area (see Fig. 2), these curves are given simply to illustrate the data trends.

The results for the static tube are given in Figs. 3b and 4b and, in contrast to the pitot tube results, show a strong dependence upon the tunnel free-stream conditions. There is little or no correlation of these data by the simple duct flow analysis as was shown for the pitot tube data, and for this reason curves of various friction parameters are not presented. These results are not surprising when one considers the complicated flow picture associated with flow into or out of the static orifices immersed in free-stream flow. Unlike the pitot tube, the flow approaching the static ports is tangential rather than normal, and neither the entering flow conditions or effective flow area at the orifices can be simply treated.

In regard to the static tube data, it should be noted that no results are presented for  $M_\infty = 1.5$  because the reflected nose shock wave intersected the probe near the location of the static orifices.

Schlieren photographs obtained during the phase when flow was being ejected through the probe tubes are presented in Fig. 5 for the probe immersed in  $M_\infty = 2$  free-stream flow to illustrate the disturbances created by the out-flow into the stream.

It was also noted during the tests that for the range of conditions investigated there was no effect on the static pressure measurement of flow into or out of the pitot tube.

#### REFERENCES

1. Test Facilities Handbook, (5th Edition). "von Kármán Gas Dynamics Facility, Vol. 4." Arnold Engineering Development Center, July 1963.
2. Anderson, A. "Flow Characteristics of a 12-in. Intermittent Supersonic Tunnel." AEDC-TDR-63-203 (AD418578), September 1963.
3. Shapiro, Ascher H. The Dynamics and Thermodynamics of Compressible Fluid Flow. Vol. 1, Chapter 6, The Ronald Press Company, New York, 1953.

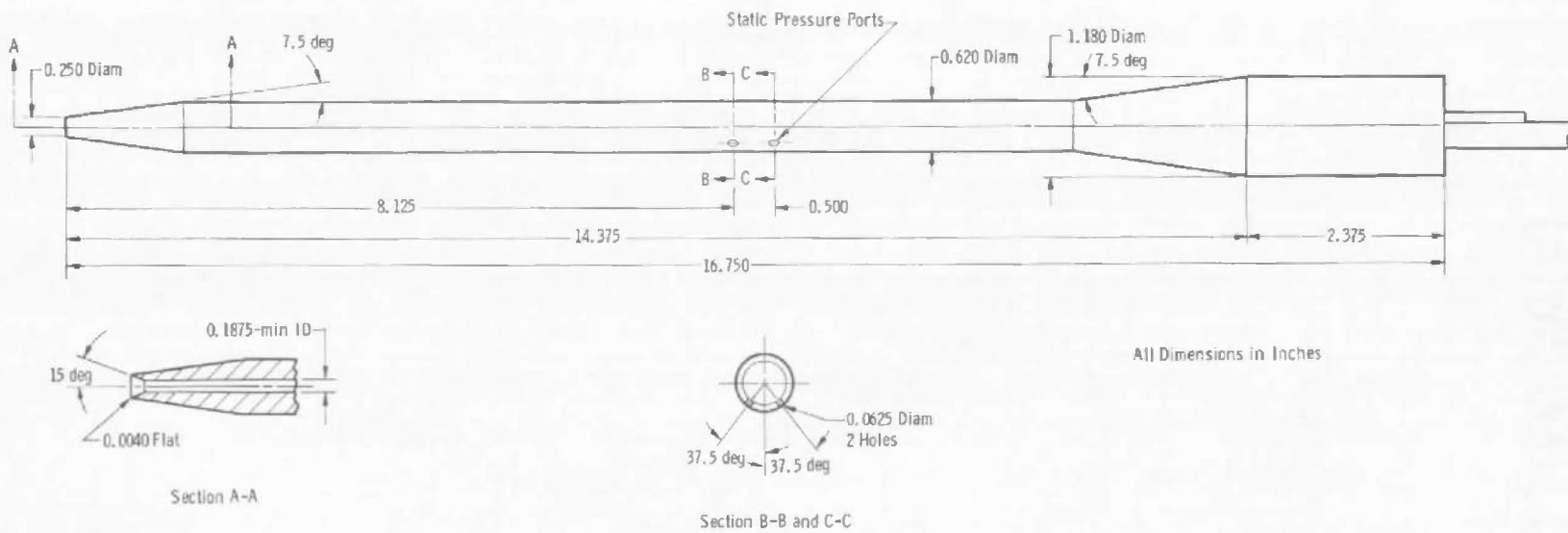
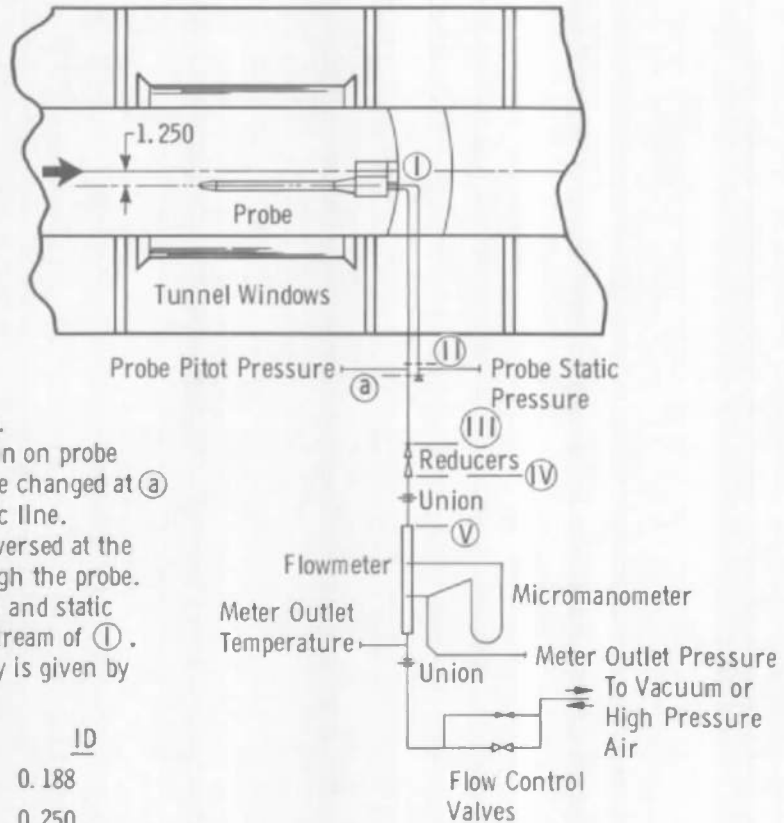

Fig. 1 Probe Geometry (Rosemount Engineering Company Type TRU-1/A)



- Note: 1. All dimensions in inches.  
 2. Setup shown is for suction on probe pitot line; connections are changed at (a) for suction on probe static line.  
 3. Flowmeter assembly is reversed at the unions for blowing through the probe.  
 4. Lines from the probe total and static ports are identical downstream of (I).  
 5. Instrument line geometry is given by the following:

Section	Length	ID
Probe Tip to (I)	18.25	0.188
Probe Static Ports to (I)	11.00	0.250
(I) to (II)	17.75	0.305
Reducers (II) to (III)	7.00	0.305
(III) to (IV)	3.00	0.375 to 0.750
(IV) to (V)	4.75	0.750

Fig. 2 Diagram of Test Equipment Installation

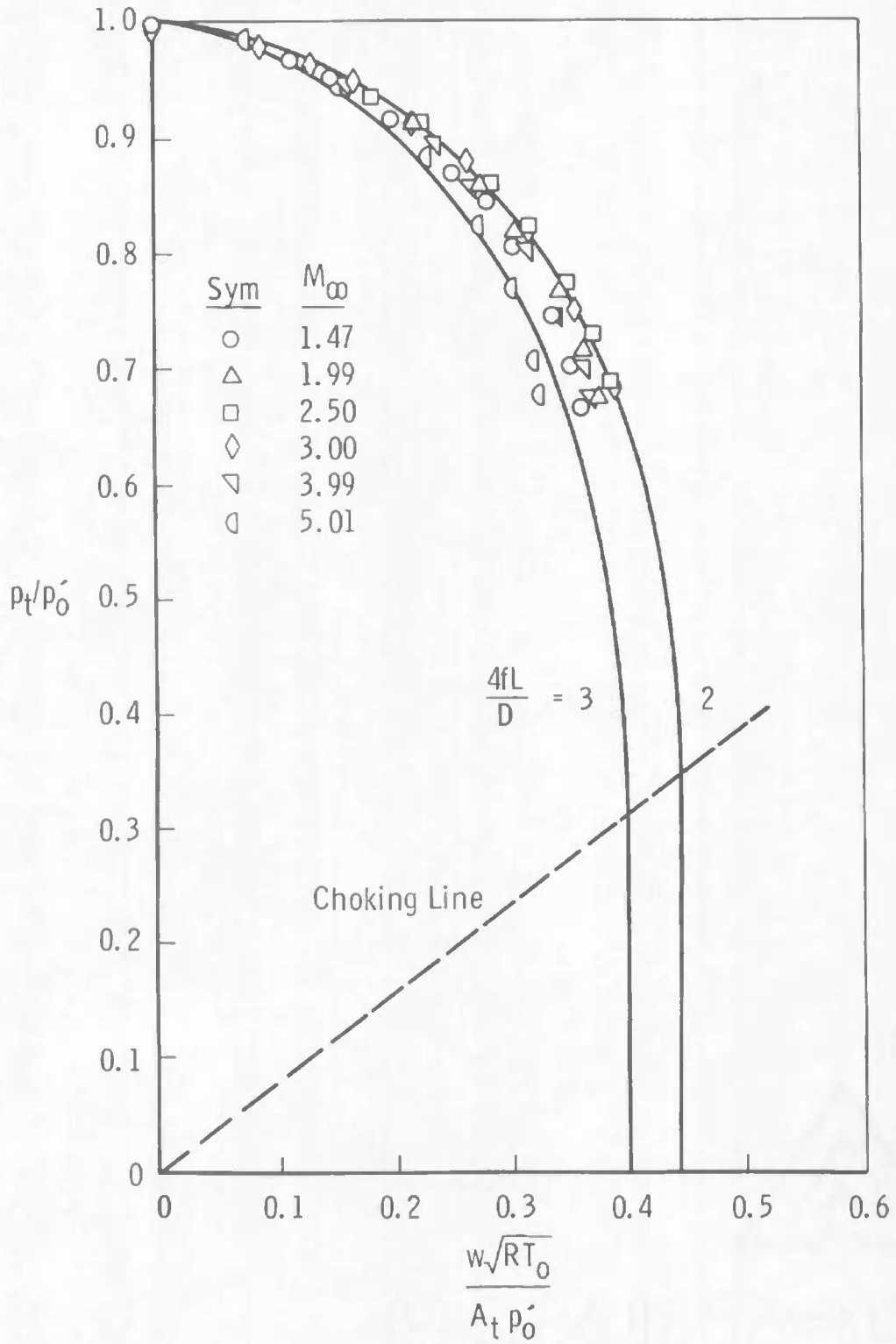

a. Pitot Duct

Fig. 3 The Effects of Flow Drawn through the Probe



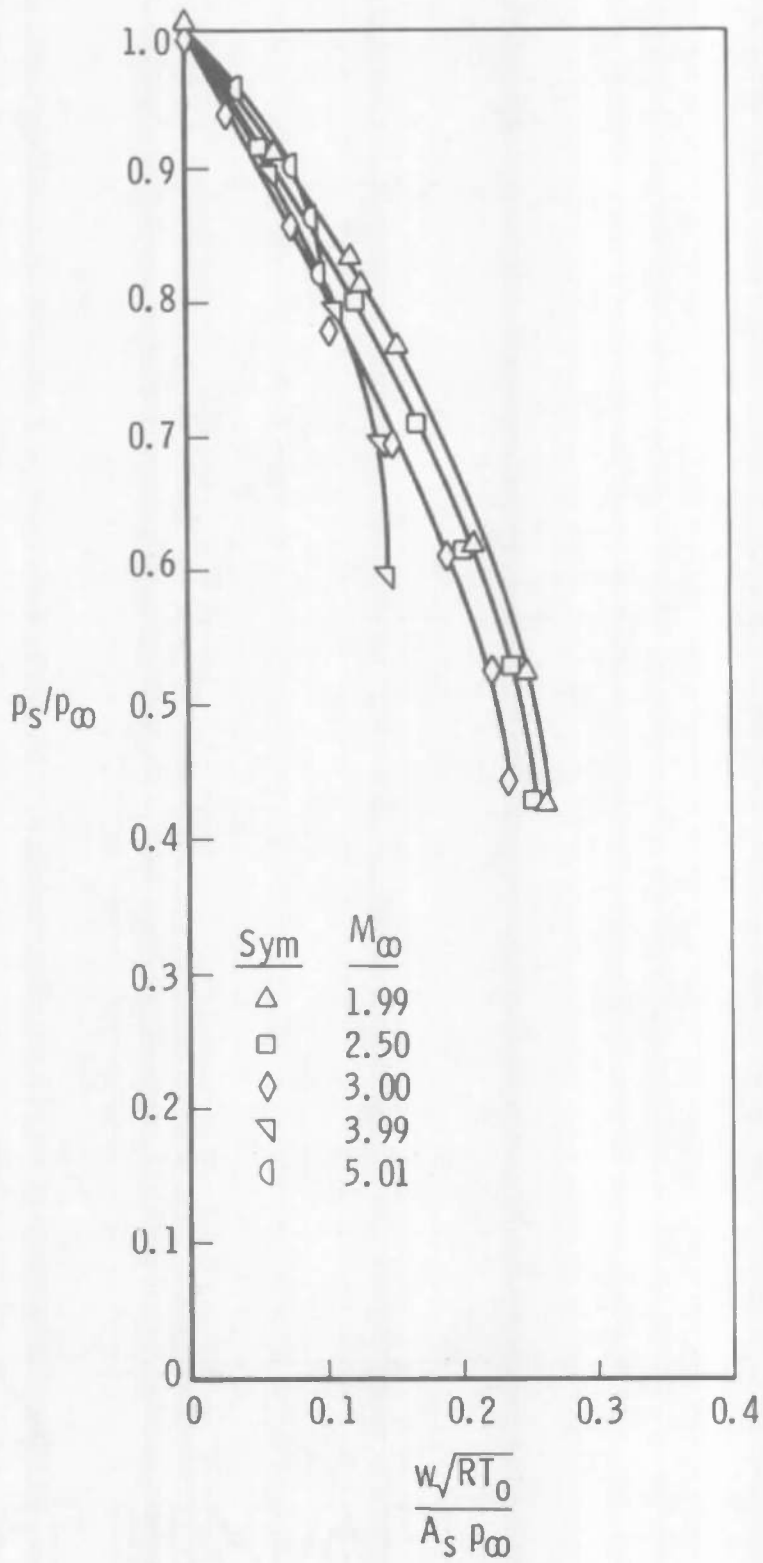

b. Static Ports

Fig. 3 Concluded

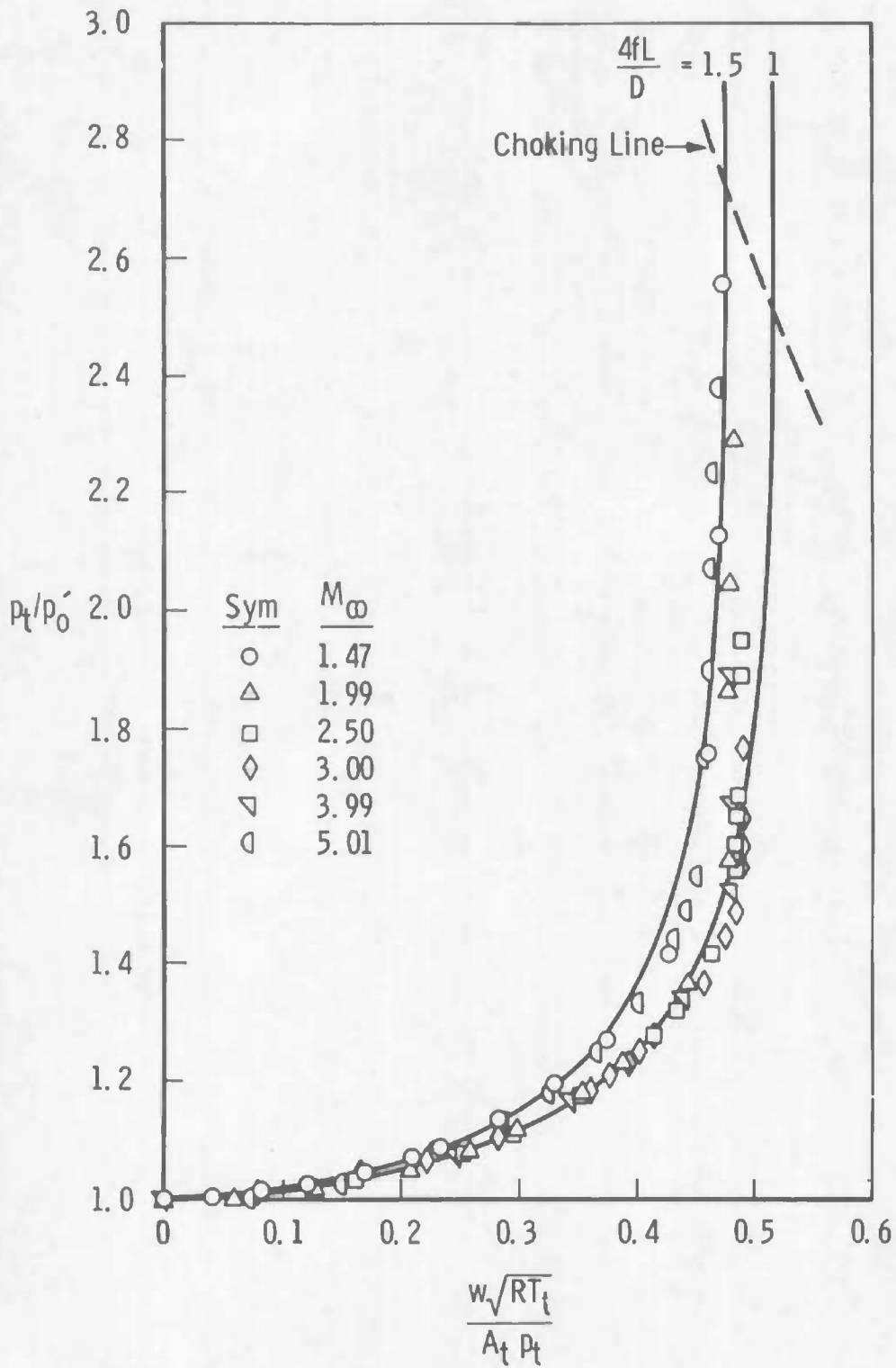

a. Pitot Duct

Fig. 4 The Effects of Flow Injected into the Probe

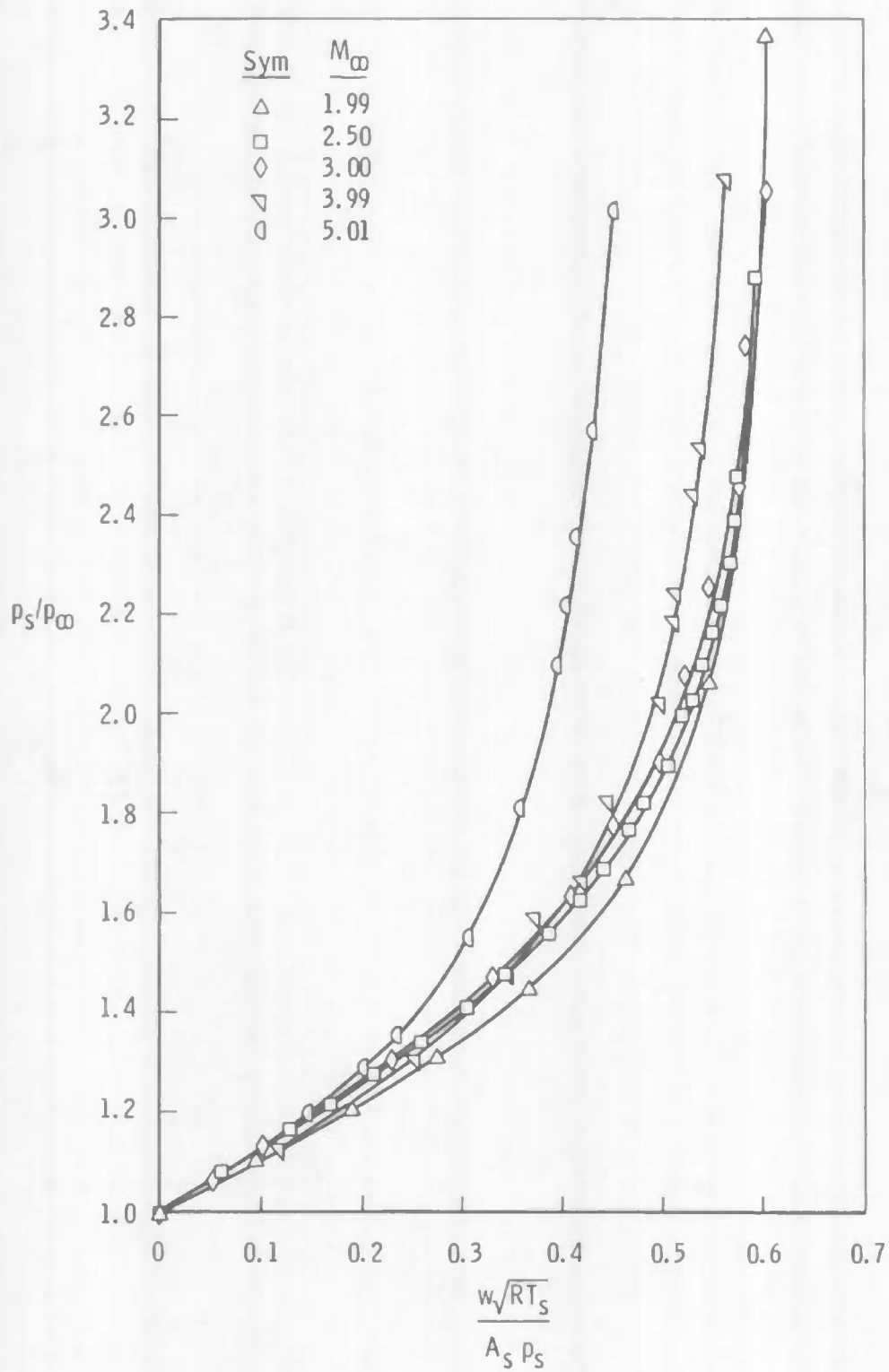

b. Static Ports

Fig. 4 Concluded

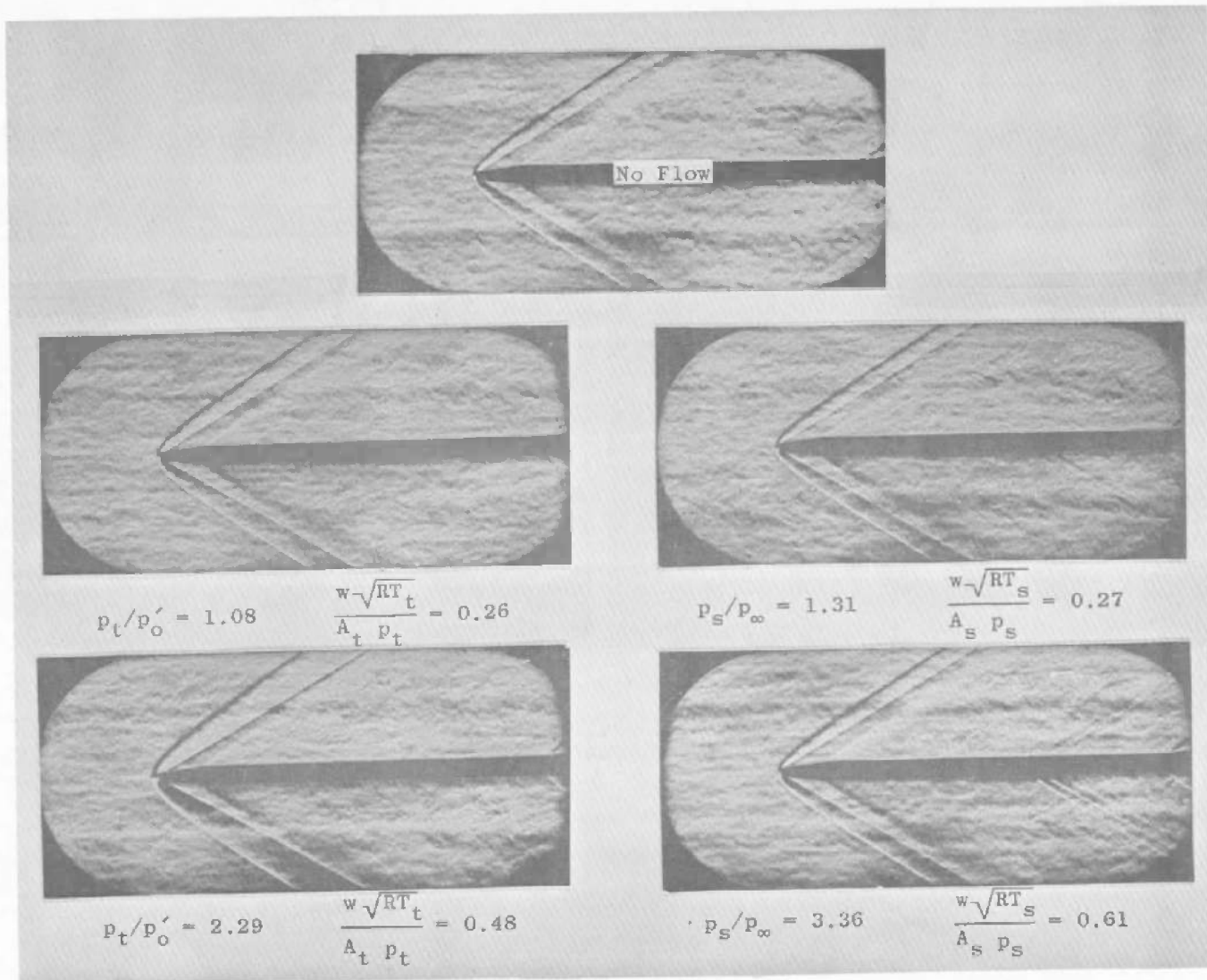

a. Pitot Duct

b. Static Ports

Fig. 5 Schlieren Photographs for Ejecting Flow through the Probe Tubes;  $M_\infty = 1.99$

TABLE I  
TEST CONDITIONS

Nominal $M_\infty$	Calibrated $M_\infty$	$p_{O_1}$ , psia	$T_{O_1}$ , °R	$Re/in.$ $\times 10^{-6}$	$p_{w_1}$ , psia	$p_{O_1}$ , psia
1.5	1.47	5.5	535	0.14	1.6	5.2
2	1.99	*5.4	535	0.12	0.7	3.9
		11.6	535	0.25	1.5	8.4
2.5	2.50	25.3	535	0.43	1.5	12.6
3	3.00	45	535	0.58	1.2	14.8
4	3.99	60	535	0.47	0.4	8.4
5	5.01	60	535	0.29	0.1	3.7

\* These data are not presented in this report.

## DOCUMENT CONTROL DATA - R&amp;D

(Security classification of title, body of abstract and indexing annotation must be entered when the overall report is classified)

1. ORIGINATING ACTIVITY (Corporate author) Arnold Engineering Development Center (AEDC) ARO, Inc., Operating Contractor Arnold Air Force Station, Tennessee		2a. REPORT SECURITY CLASSIFICATION UNCLASSIFIED	
		2b. GROUP N/A	
3. REPORT TITLE THE EFFECTS OF FLOW THROUGH AN AIRCRAFT PITOT-STATIC PROBE AT SUPERSONIC MACH NUMBERS			
4. DESCRIPTIVE NOTES (Type of report and inclusive dates) N/A			
5. AUTHOR(S) (Last name, first name, initial) Baer, A. L., ARO, Inc.			
6. REPORT DATE February 1966		7a. TOTAL NO. OF PAGES 18	7b. NO. OF REFS 3
8a. CONTRACT OR GRANT NO. AF40(600)-1200		9a. ORIGINATOR'S REPORT NUMBER(S) AEDC-TR-66-28	
8b. PROJECT NO. 8222		9b. OTHER REPORT NO(S) (Any other numbers that may be assigned this report) N/A	
c. Program Element 62405364			
d. Task 822207			
10. AVAILABILITY/LIMITATION NOTICES <del>Qualified users may obtain copies of this report from DDC and transmittal of this document outside of DOD and release to foreign governments and foreign nationals must have prior approval of AFFDL (FDCL).</del>			
11. SUPPLEMENTARY NOTES N/A		12. SPONSORING MILITARY ACTIVITY Air Force Flight Dynamics Laboratory (AFFDL), Air Force Systems Command, Wright-Patterson AFB, Ohio	
13. ABSTRACT Tests of a standard, aircraft-type, pitot-static probe were conducted in the 12-in. supersonic tunnel of the von Karman Gas Dynamics Facility to evaluate the effects on the probe total and static pressures resulting from drawing flow from the tube or putting flow into the tube. The data were obtained with the probe at zero angle of attack in a supersonic stream at Mach numbers from 1.5 to 5, and the Reynolds number per inch ranged from $0.12 \times 10^6$ to $0.58 \times 10^6$ . The results are presented in terms of the ratio of measured probe pressure to the pressure for no tube flow as a function of a nondimensional parameter representing the quantity of flow being passed through the tube.			

This document has been approved for public release  
its distribution is unlimited. Per TAB 73-6, 1973  
dtd 15 March, 1973

