

UNCLASSIFIED

AD NUMBER

AD474437

LIMITATION CHANGES

TO:

Approved for public release; distribution is unlimited.

FROM:

Distribution authorized to U.S. Gov't. agencies and their contractors;
Administrative/Operational Use; OCT 1965. Other requests shall be referred to Army Edgewood Arsenal Chemical Research and Development Laboratory, Weapons Research Division, Edgewood Arsenal, MD 21010.

AUTHORITY

usaea ltr, 10 dec 1971

THIS PAGE IS UNCLASSIFIED

SECURITY

MARKING

The classified or limited status of this report applies to each page, unless otherwise marked.

Separate page printouts MUST be marked accordingly.

THIS DOCUMENT CONTAINS INFORMATION AFFECTING THE NATIONAL DEFENSE OF THE UNITED STATES WITHIN THE MEANING OF THE ESPIONAGE LAWS, TITLE 18, U.S.C., SECTIONS 793 AND 794. THE TRANSMISSION OR THE REVELATION OF ITS CONTENTS IN ANY MANNER TO AN UNAUTHORIZED PERSON IS PROHIBITED BY LAW.

NOTICE: When government or other drawings, specifications or other data are used for any purpose other than in connection with a definitely related government procurement operation, the U. S. Government thereby incurs no responsibility, nor any obligation whatsoever; and the fact that the Government may have formulated, furnished, or in any way supplied the said drawings, specifications, or other data is not to be regarded by implication or otherwise as in any manner licensing the holder or any other person or corporation, or conveying any rights or permission to manufacture, use or sell any patented invention that may in any way be related thereto.

AD

CRDL Special Publication 1-54

424437

BURNING TEMPERATURES AND PRESSURES OF M18
COLORED-SMOKE GRENADES

by

Guy Haynes

October 1965



Weapons Research Division
Directorate of Weapons Systems
US Army Edgewood Arsenal
CHEMICAL RESEARCH AND DEVELOPMENT LABORATORIES
Edgewood Arsenal, Maryland 21010

Defense Documentation Center Availability Notice

Qualified requesters may obtain copies of this report from
Defense Documentation Center, Cameron Station, Alexandria,
Virginia 22314

NOT RELEASABLE TO Clearinghouse for Federal
Scientific and Technical Information.

**US Army Edgewood Arsenal
CHEMICAL RESEARCH AND DEVELOPMENT LABORATORIES**

Special Publication 1-54

**BURNING TEMPERATURES AND PRESSURES OF M18
COLORED-SMOKE GRENADES**

by

Guy Haynes

**Weapons Research Division
Directorate of Weapons Systems**

October 1965

Edgewood Arsenal, Maryland 21010

FOREWORD

This work was conducted under Task 1C522301A98101, Chemical Agent Dissemination Technology (U). The work was started in May 1964 and completed in August 1964. The experimental data are contained in notebook 7319.

Acknowledgments

The author acknowledges the technical assistance of Messrs. M. E. Penn and G. A. Sweany.

Notices

Reproduction of this document in whole or in part is prohibited except with permission of US Army Edgewood Arsenal Chemical Research and Development Laboratories; however, DDC is authorized to reproduce the document for United States Government purposes.

The information in this report has not been cleared for release to the general public.

Disclaimer

The findings in this report are not to be construed as an official Department of the Army position, unless so designated by other authorized documents.

Disposition

When this report has served its purpose, DESTROY it.

DIGEST

Standard transducers will measure directly burning pressure, burning temperature, and weight loss during burning. Burning time is readily derived from either pressure or weight-loss data.

There is a great deal of variation in the functioning data obtained from any one type of munition.

The most noticeable measured difference between the colored-smoke grenades tested was in burning temperature. Red and yellow grenades burned cooler than did green and violet grenades.

CONTENTS

	<u>Page</u>
I. INTRODUCTION.....	5
II. PROCEDURE AND RESULTS	5
A. Pressure Measurements	5
B. Temperature Measurements.....	6
C. Weight Change.....	7
D. Burning Times.....	8
III. DISCUSSION	9
IV. CONCLUSIONS.....	10
APPENDIXES.....	11
A. M18 Grenade Lot Number, Date of Manufacture, and Composition.....	12
B. Figures, B1 through B6.....	13
DOCUMENT CONTROL DATA - R&D, DD FORM 1473, WITH ABSTRACT AND KEYWORDS.....	19

BURNING TEMPERATURES AND PRESSURES OF M18 COLORED-SMOKE GRENADES

I. INTRODUCTION.

The objective of this study was to provide a potential input to design criteria and mechanism studies pertaining to pyrotechnic-dissemination processes. The techniques used were developed to obtain data on several of these parameters. Since this was a preliminary investigation, the parameters under investigation were the most obvious; i. e., burning temperature, pressure, weight change, and burning time.

A search of the available literature revealed that none of the above parameters seems to have been tabulated, nor are details available on experimental design required to obtain these parameters. Therefore, this work on the M18 colored-smoke grenade was undertaken as part of a continuing program to obtain data applicable to chemical-agent-dissemination technology. The lot number, composition, and date of manufacture of the grenades are listed in appendix A.

II. PROCEDURE AND RESULTS.

Since colored smoke rather than a toxic agent was involved, the munitions were burned in the open. Pressure and temperature were measured on a grenade while it functioned in a horizontal position on a gravel surface. The grenades used for weight measurements were also functioned in a horizontal position.

A. Pressure Measurements.

Pressure measurements were made with a temperature-compensated pressure transducer, which was obtained from Statham Instruments, Inc. The range of this unit is 0 to 15 psi differential, and it is rated as capable of withstanding a 100% overload. This transducer was excited with 14.0 v dc.

A Leeds & Northrup H-Azar strip-chart recorder, with chart speeds of 30 or 1,800 in./hr, was used to record pressure during burning. Pressure connection to the grenade was made with a locally constructed, brass T fitting that is illustrated schematically in figure B1A (all figures, B1 through B6, are given in appendix B). The straight portion of the T fitting has bouchon threads. A female end is provided to receive the fuze, and the male end attaches to the grenade, where the fuze would normally

be connected. The side branch of the T fitting is threaded to receive 3/8-in. copper tubing with a flare fitting. Rubber tubing is used as a connection from the tubing to the transducer. This arrangement makes the pressure line flexible enough to move either the munition or the pressure transducer independently.

The results of these tests are given in table 1. Figures B2 through B4 show representative pressure measurements.

TABLE 1

INTERNAL PRESSURE OF FUNCTIONING COLORED-SMOKE GRENADES

Color	Number of samples	Pressure range during normal burn	Average number of times orifice plugged per grenade	Range of maximum pressures during plugs
		psi		psi
Green	4	0.05 - 1	5	4 - 21
Red	6	0.04 - 0.41	0	—
Violet	4	0.03 - 1	6	7 - 22
Yellow	6	0.03 - 0.6	0	—

B. Temperature Measurements.

Temperature measurements were made with a shielded, Chromel-Alumel thermocouple equipped with a Minicomp artificial cold junction (Technique Associates, a division of West Instrument Co.). The recorder chart speed utilized was 120 in./hr.

The full-scale recorder range was adjusted for 1,000°C full scale. The temperature-millivolt relation for Chromel-Alumel is not linear, but, in the range from 400° to 1,000°C, the error is not greater than 1.2%.

The tip of the thermocouple was placed in the center of the test munition. In a few tests, however, the functioning was violent enough to move the munition away from the fixed thermocouple. Whenever such movement obviously affected the measurement, these measurements were discarded. Figure B5 shows a typical temperature-behavior recording.

The results of these tests are shown in table 2.

TABLE 2
TEMPERATURES OCCURRING IN FUNCTIONING
COLORED-SMOKE GRENADES

Color	Number of samples	Temperature range during burning*
		°C
Green	4	580 - 750
Red	5	440 - 610
Violet	5	630 - 780
Yellow	4	420 - 510

* A temperature variation of about 50°C was observed during the burning of individual items.

C. Weight Change.

Weight change during burning was measured with a weight transducer (Statham Instruments, Inc.) with a range of ±32 oz. The unit was mounted in a locally fabricated, stainless-steel case, which also provided a means for mounting the munition. The transducer was excited with 14.0 v dc.

A Leeds & Northrup H-Azar strip-chart recorder, with a chart speed of 120 in./hr, was used to record weight change during burning.

Some provision on the grenades was needed to catch the slag-type material that escaped from the ends. As a result of orifice plugging, the hot slag was sometimes expelled with great violence. The tops of the containers that had originally held the grenades were modified and taped to the ends of the grenades. This proved to be satisfactory, although some very small quantities of slag were later detected on the transducer case. The weight of this lost material was negligible.

Each grenade to be checked for weight loss was ignited with an electric fuze. The connecting wires were cut immediately after ignition. This was necessary because some of the grenades had a tendency to rotate while burning on the weight transducer. If a grenade rotated with the ignition wires still connected, erroneous results were obtained. Figure B6 shows typical recordings of weight-loss measurement.

The results of these tests are shown in table 3.

TABLE 3
WEIGHT LOST FROM COLORED-SMOKE
GRENADDES WHILE BURNING

Color	Number of samples	Range of weight losses
		gm.
Green	3	195 - 238
Red	2	222 - 233
Violet	3	198 - 252
Yellow	2	145 - 148

D. Burning Times.

Burning times could be measured directly from pressure or weight-loss curves. In the former, burning is considered to be complete when the pressure reading returns to base line. In the latter, weight loss ceases when the munition stops functioning. Both methods give definite burning times. No comparison was made with manual, stopwatch, burning-time measurements. Thermocouple data were found to be unusable, since no real break in the temperature curve occurred after burning was completed. Burning-time data acquired from the above two systems are included in table 4.

TABLE 4

BURNING TIMES FOR COLORED-SMOKE GRENADES

Color	Number of samples	Range of burning times	Average burning time
			sec
Green	7	45 - 57	52
Red	8	52 - 83	66
Violet	7	47 - 71	59
Yellow	8	51 - 60	55

III. DISCUSSION.

The results of these tests indicate that colored-smoke grenades are variable in their burning characteristics. Visual observation shows that green and violet grenades sometimes burn erratically, whereas red and yellow grenades burn more uniformly.

The normal burning pressure for any colored-smoke grenade is less than 1 psi. Orifice plugging takes place in the green and violet grenades, however, on the average of five or six times per unit, respectively, suddenly increasing the pressure to approximately 20 psi. This orifice plugging is the result of the thick, liquid, reaction products flowing through the orifices during combustion. When the internal pressure becomes great enough, the reaction products are blown through the exhaust orifice to distances as great as 10 ft. Normal burning pressure then resumes until the exhaust opening again becomes blocked.

The equipment worked well as described; during consecutive tests, however, reuse of the brass pressure tap was difficult because of the problem of unscrewing it from a hot grenade. It is recommended that duplicate pressure taps be made available for any future program requiring such measurements.

The section of rubber hose between the munition and the pressure transducer served as a safety valve in addition to providing flexibility. In this capacity, it blew off four times. These incidents occurred early in the program, with measurements indicating pressures greater than 20 psi. The maximum pressure recorded later was 22 psi, but the pulse pressures may have been higher.

Temperature was the most uniform of the variables. It rose quite rapidly and then remained nearly constant during functioning and for some time afterwards.

Rate of weight change remained nearly constant during the final three-fourths of burning time.

Burning time was easily measured from either the pressure or the weight recording. No correlation could be seen between burning time and weight change, either for individual grenades or for averages of colors. This may be a result of the extremely limited number of tests, three per color, in which this variable was measured.

The values given in table 1 are probably fairly representative of M18 colored-smoke grenades when functioned in a horizontal position, which is the way most such grenades would land if thrown. Although other positions might affect the exhaust-orifice-plugging problem and the resultant pressures, time limitations precluded experiments on the effect of position.

IV. CONCLUSIONS.

1. Standard transducers will measure directly burning pressure, burning temperature, and weight loss during burning. Burning time is readily derived from either pressure or weight-loss data.

2. There is a great deal of variation in the functioning data obtained from any one type of munition.

3. The most noticeable measured difference between the colored-smoke grenades tested was in burning temperature. Red and yellow grenades burned cooler than did green and violet grenades.

APPENDIXES

<u>Appendix</u>		<u>Page</u>
A.	M18 Grenade Lot Number, Date of Manufacture, and Composition.....	12
B.	Figures, B1 through B6	13

APPENDIX A

M18 GRENADE LOT NUMBER, DATE OF MANUFACTURE, AND COMPOSITION

Color	Lot number	Date of manufacture	Number	Compositio	
				Components	Percent
Red	1021-24-13	January 1962	MLD 196-111-670	1-(Methylamino)anthraquinone	40
				Potassium chlorate	30.3
				Sulfur	11.7
				Sodium bicarbonate	18
Yellow	1022-24-11	February 1962	MLD 5029B	Benzanthrone, 65 parts; vat yellow IV, 35 parts	37
				Potassium chlorate	19
				Sulfur	12
				Sodium bicarbonate	31
Green	PB 16008-10	November 1960	MLD 5074B	1, 4-p-Toluidinoanthraquinone, two parts;	46
				yellow dye mix, one part	27
				Potassium chlorate	10
				Sulfur	22
Violet	PB 26009-11	September 1961	MLD 196-111-670	Sodium bicarbonate	42
				1, 4-Diamino-2, 3-dihydroxyanthraquinone, one part;	28.8
				1-methylaminoanthraquinone, one part	11.2
				Potassium chlorate	18

APPENDIX B

FIGURES

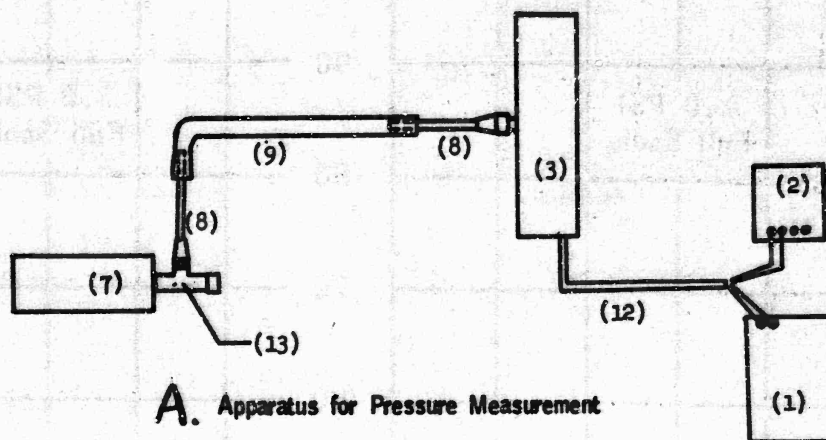

A. Apparatus for Pressure Measurement

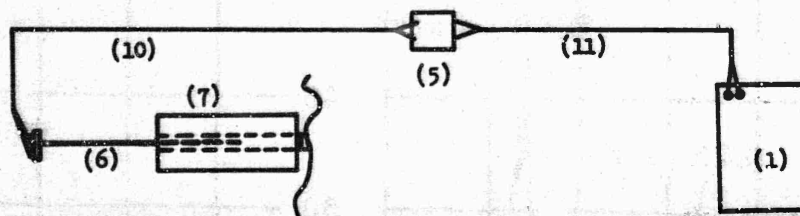

B. Apparatus for Temperature Measurement

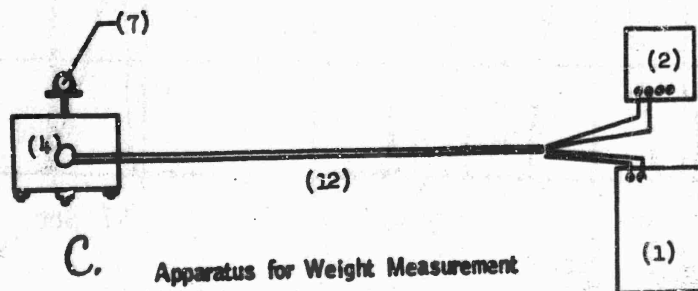

C. Apparatus for Weight Measurement

FIGURE B1

EQUIPMENT LAYOUT

(1, H-Azar recorder; 2, power supply, 14.0 v dc; 3, pressure transducer; 4, weight transducer; 5, Minicomp artificial cold junction; 6, Chromel-Alumel thermocouple; 7, M18 colored-smoke grenade; 8, copper tubing, 3/8 in.; 9, rubber tubing; 10, Chromel-Alumel wire; 11, cable, two-conductor, copper; 12, cable, four-conductor, shielded; 13, brass T fitting)

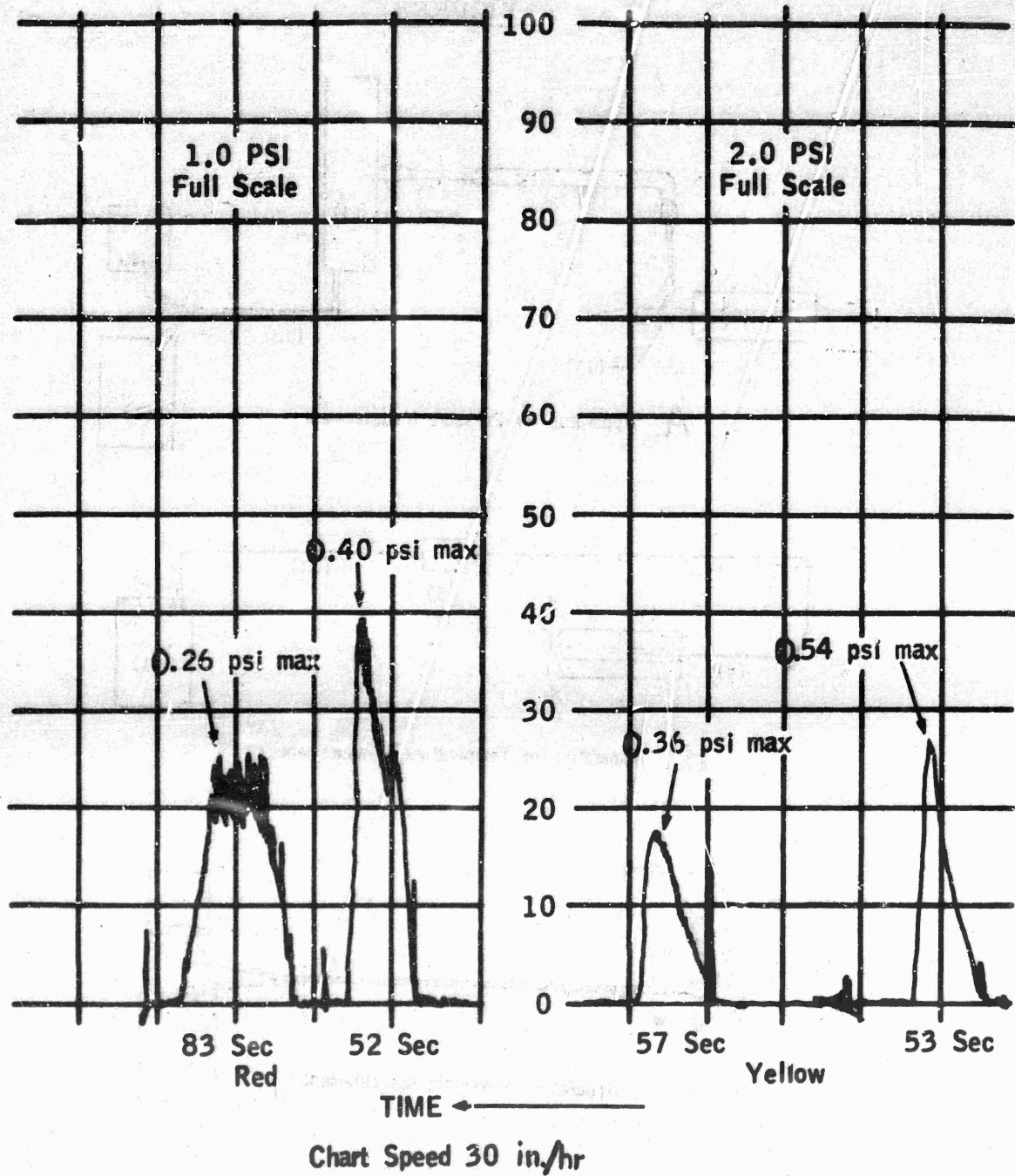

FIGURE B2

TYPICAL RECORDINGS OF INTERNAL PRESSURE OF FUNCTIONING
RED AND YELLOW SMOKE GRENADES

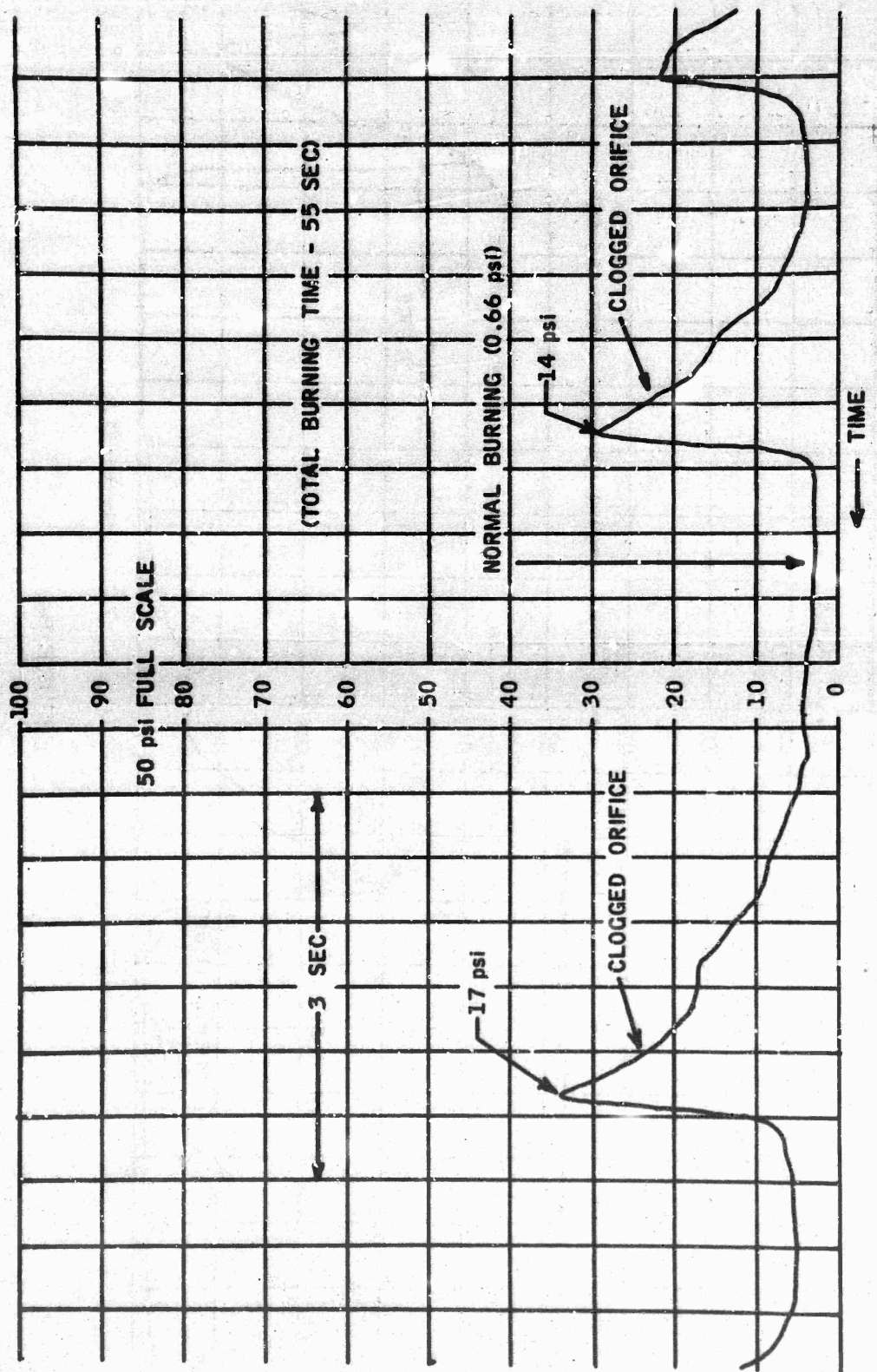

FIGURE B3

TYPICAL SECTION OF PRESSURE RECORDING FOR VIOLET WITH RECORDER ON FAST SPEED (1,800 IN./HR)

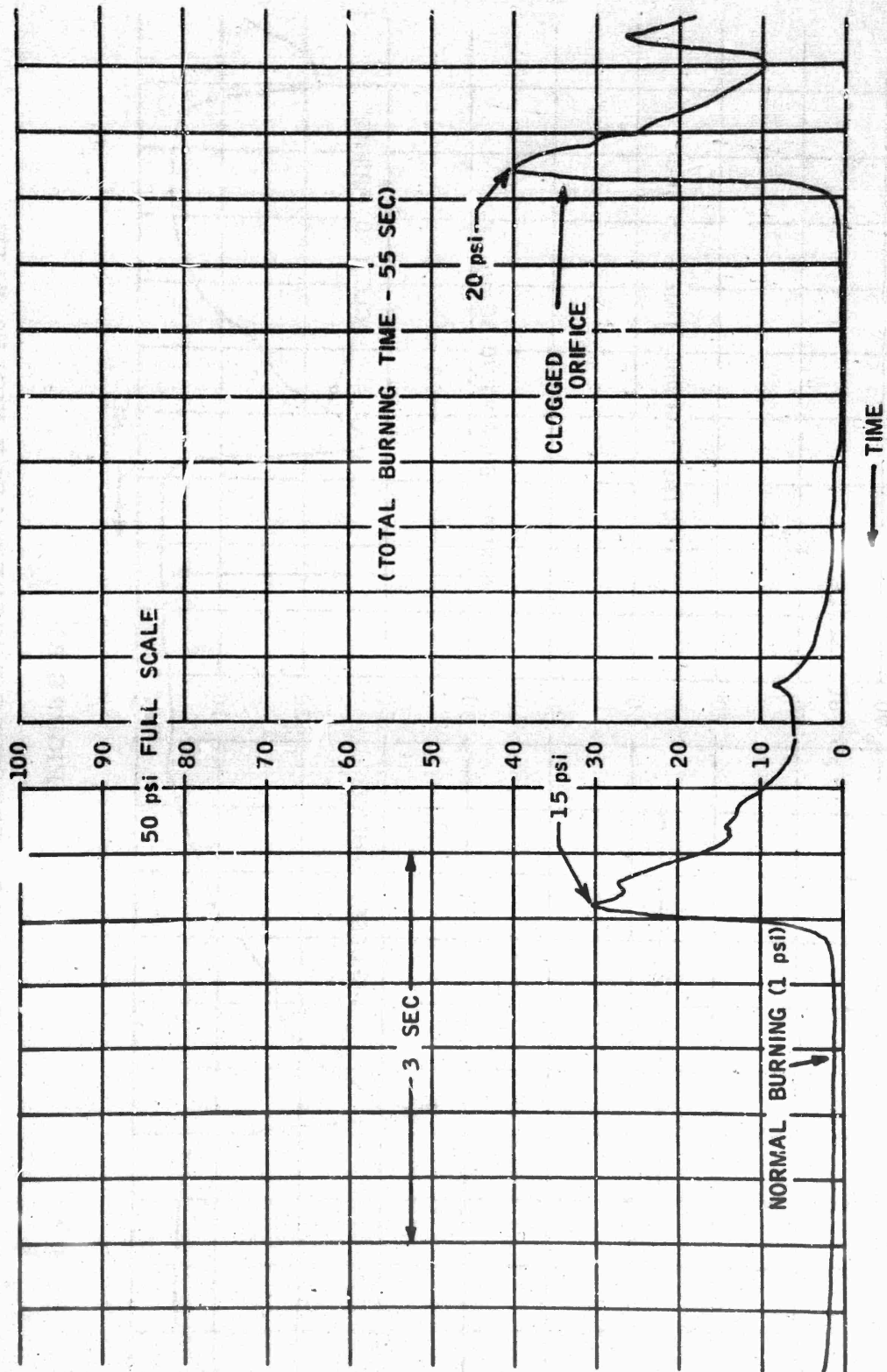

FIGURE B4

TYPICAL SECTION OF PRESSURE RECORDING FOR GREEN WITH
RECORDER ON FAST SPEED (1,800 IN./HR)

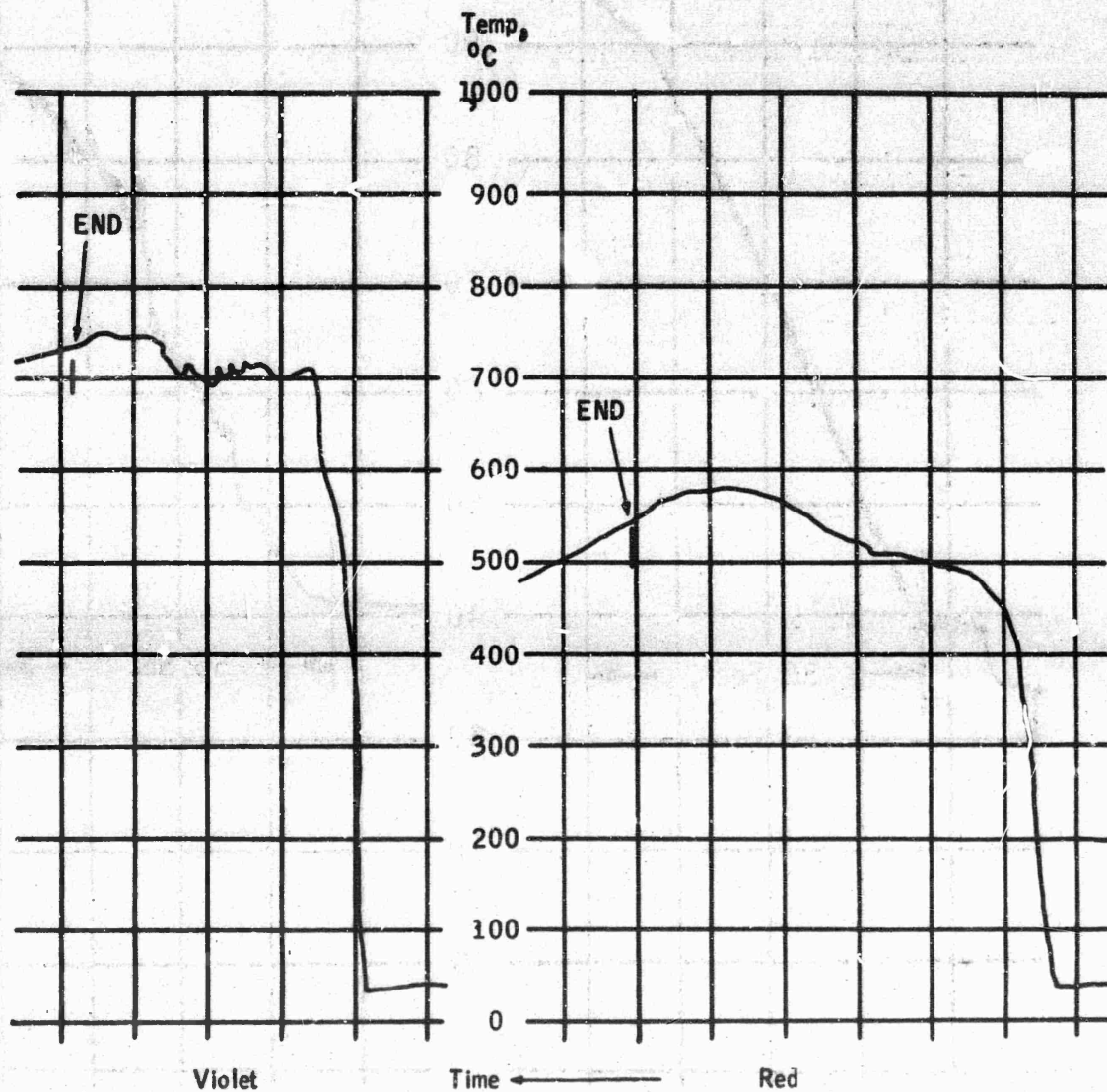

FIGURE B5

TYPICAL RECORDINGS OF TEMPERATURE

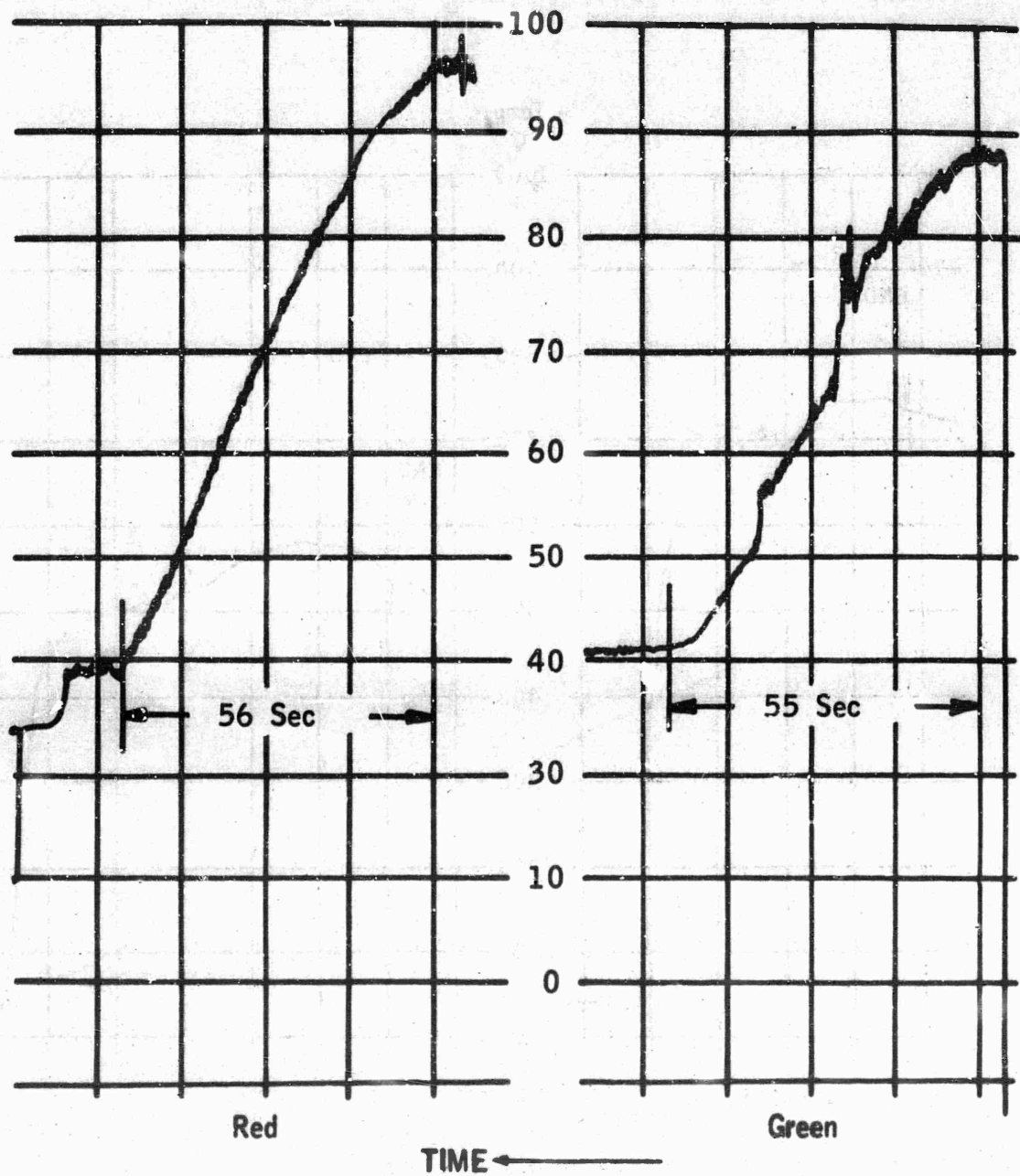

FIGURE 36

TYPICAL RECORDINGS OF WEIGHT CHANGE DURING BURNING

UNCLASSIFIED

Security Classification

DOCUMENT CONTROL DATA - R&D

024640
(Security classification of title, body of abstract and indexing annotation must be entered when the overall report is classified)

1. ORIGINATING ACTIVITY <i>(Corporate author)</i> US Army Edgewood Arsenal Chemical Research and Development Laboratories, Edgewood Arsenal, Md. 21010 Weapons Research Division		2a. REPORT SECURITY CLASSIFICATION UNCLASSIFIED	
		2b. GROUP N/A	
3. REPORT TITLE BURNING TEMPERATURES AND PRESSURES OF M18 COLORED-SMOKE GRENADES			
4. DESCRIPTIVE NOTES <i>(Type of report and inclusive dates)</i> This work was started in May 1964 and completed in August 1964.			
5. AUTHOR(S) <i>(Last name, first name, initial)</i> Haynes, Guy			
6. REPORT DATE October 1965		7a. TOTAL NO. OF PAGES 019	7b. NO. OF REFS None
8a. CONTRACT OR GRANT NO.		8a. ORIGINATOR'S REPORT NUMBER(S) CRDL Special Publication 1-54	
b. PROJECT NO.			
c. Task No. LC522301A08101		8b. OTHER REPORT NO(S) <i>(Any other numbers that may be assigned this report)</i>	
d. Work Unit.		N/A	
10. AVAILABILITY/LIMITATION NOTICES Qualified requesters may obtain copies of this report from Defense Documentation Center, Cameron Station, Alexandria, Virginia 22314			
11. SUPPLEMENTARY NOTES Chemical-agent dissemination		12. SPONSORING MILITARY ACTIVITY N/A	
13. ABSTRACT Parameters pertaining to pyrotechnic dissemination processes were investigated. Burning-temperature, burning-time, weight-change, and pressure parameters were recorded for the M18, colored-smoke grenade with a thermocouple, from pressure- or weight-loss curves, with a weight transducer, and with a pressure transducer, respectively. Equipment layouts and samples of strip-chart recordings are presented. Burning pressure is usually less than 1 psi; however, orifice plugging can increase pressure to about 20 psi. Any one type of munition yields a great variation in functioning data. Burning temperature is lower in red and yellow M18 grenades than in green and violet ones.			
14. KEYWORDS			
Parameters	Burning time	M18 colored smoke grenades	
Burning temperature	Pressure	Thermocouple	
Weight	Transducer		