

UNCLASSIFIED

AD NUMBER
AD469632
NEW LIMITATION CHANGE
TO Approved for public release, distribution unlimited
FROM Distribution authorized to U.S. Gov't. agencies and their contractors; Administrative/Operational Use; 13 SEP 1965. Other requests shall be referred to Army Missile Command, Redstone Arsenal, AL.
AUTHORITY
MICOM ltr dtd 15 Dec 1965

THIS PAGE IS UNCLASSIFIED

SECURITY

MARKING

The classified or limited status of this report applies to each page, unless otherwise marked.

Separate page printouts MUST be marked accordingly.

THIS DOCUMENT CONTAINS INFORMATION AFFECTING THE NATIONAL DEFENSE OF THE UNITED STATES WITHIN THE MEANING OF THE ESPIONAGE LAWS, TITLE 18, U.S.C., SECTIONS 793 AND 794. THE TRANSMISSION OR THE REVELATION OF ITS CONTENTS IN ANY MANNER TO AN UNAUTHORIZED PERSON IS PROHIBITED BY LAW.

NOTICE: When government or other drawings, specifications or other data are used for any purpose other than in connection with a definitely related government procurement operation, the U. S. Government thereby incurs no responsibility, nor any obligation whatsoever; and the fact that the Government may have formulated, furnished, or in any way supplied the said drawings, specifications, or other data is not to be regarded by implication or otherwise as in any manner licensing the holder or any other person or corporation, or conveying any rights or permission to manufacture, use or sell any patented invention that may in any way be related thereto.

DISCLAIMER NOTICE

THIS DOCUMENT IS BEST QUALITY PRACTICABLE. THE COPY FURNISHED TO DTIC CONTAINED A SIGNIFICANT NUMBER OF PAGES WHICH DO NOT REPRODUCE LEGIBLY.

CATALOGED BY: DDC
AS AD No. 469632

ROHM & HAAS COMPANY

REDSTONE ARSENAL RESEARCH DIVISION
HUNTSVILLE, ALABAMA

SPECIAL REPORT NO. S-87

A MICROWAVE TECHNIQUE FOR STUDYING
DETONATION PHENOMENA

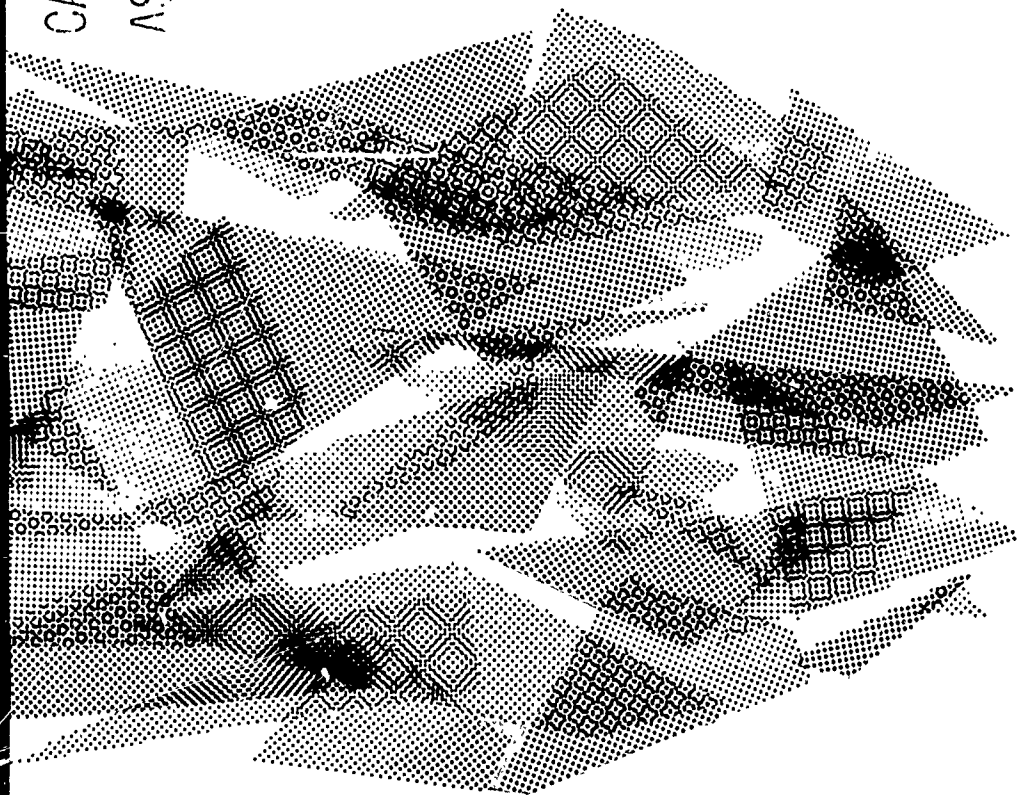

U.S. ARMY MISSILE COMMAND

DDC

SEP 16 1965

RECEIVED
DDC-RA E

Copy No. 65-6

ROHM & HAAS COMPANY

REDSTONE ARSENAL RESEARCH DIVISION
HUNTSVILLE, ALABAMA

REPORT NO. S-87

A MICROWAVE TECHNIQUE FOR STUDYING DETONATION PHENOMENA

by

Edgar G. Johnson

Approved:



Louis Brown, Head
Ballistics Section

Contract Number:
DA-01-021 ORD-11,909(Z)



O. H. Loeffler
General Manager

September 13, 1965

ACKNOWLEDGMENTS

I wish to thank Dr. H. M. Shuey for suggesting this problem and for his continued encouragement, Mr. J. E. DeMore for his advice and assistance with the instrumentation, and Dr. K. F. Ockert and Dr. T. H. Pratt for their advice and assistance in performing these experiments.

ROHM & HAAS COMPANY

REDSTONE ARSENAL RESEARCH DIVISION
HUNTSVILLE, ALABAMA

A MICROWAVE TECHNIQUE FOR STUDYING DETONATION PHENOMENA

ABSTRACT

A microwave technique has been developed for studying shock phenomena in condensed phases. The microwave energy reflected by the shock front has been used to determine velocities of both reactive (detonation) and non-reactive shocks.

This technique used standard microwave components and an expendable, dielectric rod waveguide as a transmission line to the sample under study. The oscillogram of the output of a crystal detector is a continuous displacement-time trace of the shock front as it moves through the sample. The trace can be interpreted in terms of microwave interferometry, in that the detected signal goes through a maximum and a minimum for each displacement of the shock front by a half wavelength, or as the Doppler shift in frequency produced by the velocity of the approaching shock front.

This technique has been applied to the problem of determining the growth to detonation near the 50% card gap value of 1-inch diameter charges of Composition C-4 explosive and of 2-inch diameter charges of ammonium perchlorate confined in glass. Simultaneous microwave and streak-camera measurements of the detonation of 2-inch diameter charges of pentolite have been made.

TABLE OF CONTENTS

	<u>Page</u>
INTRODUCTION	1
EXPERIMENTAL	2
GROWTH TO DETONATION IN AMMONIUM PERCHLORATE	5
GROWTH TO DETONATION IN COMPOSITION C-4	9
DETONATION OF PENTOLITE	15
CONCLUSION	18
REFERENCES	19

ROHM & HAAS COMPANY

REDSTONE ARSENAL RESEARCH DIVISION
HUNTSVILLE, ALABAMA

INTRODUCTION

A technique of microwave interferometry has been developed for studying shock phenomena in condensed phases. This technique is applicable to many explosives and other materials of interest in solid propellant research because they have relatively low losses at microwave frequencies. It can be used with both reactive (detonation) and non-reactive shocks. The technique yields an oscillogram that is a continuous displacement-time trace of the shock front as it moves through the sample.

The use of microwaves in detonation studies has been previously reported by Cook, Doran and Morris (1), who used a horn antenna and a lens to focus the microwave energy into the end of a cylindrical charge. This method was limited by multiple modes of propagation in the charge. Another investigation, reported by Cawsey, Farrands, and Thomas (2), used a charge confined in a metal waveguide of a diameter small enough (0.152 inches at 34.5 Gc/sec) that only one mode of propagation was possible.

EXPERIMENTAL

Standard microwave equipment has been used at frequencies between 10 and 33 Gc/sec which correspond to a free space wavelength of from 3 to about 1 cm. A schematic diagram of the instrumentation used is shown in Fig. 1.

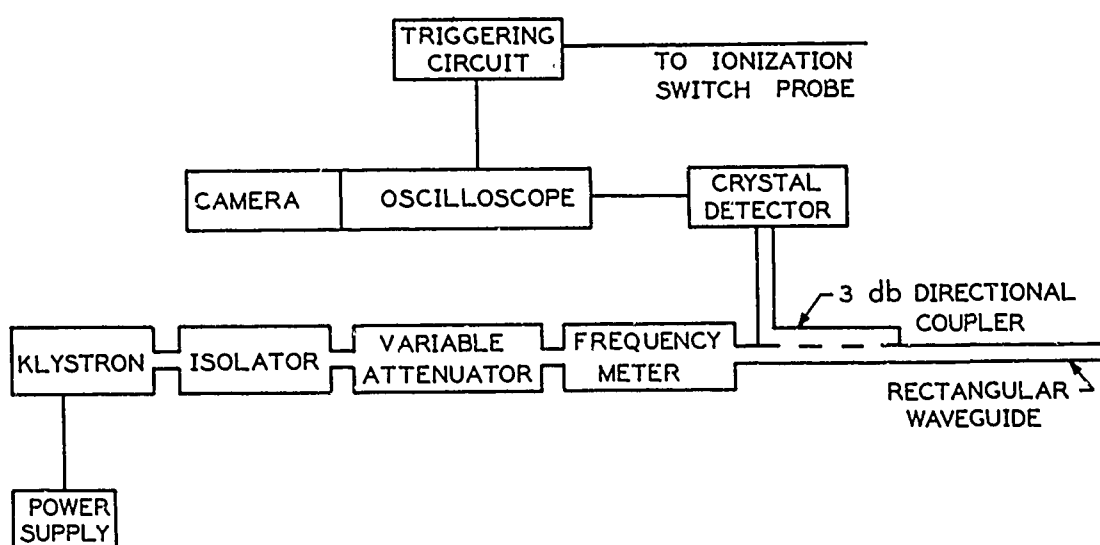

FIG. 1 SCHEMATIC DIAGRAM OF THE INSTRUMENTATION.

The klystron generated the microwave energy, the attenuator was used to adjust the power level, and the frequency meter was used to determine the microwave frequency. The directional coupler was used to separate the transmitted from the reflected energy and was oriented in the transmission line to pass the reflected energy. The crystal detector was used to monitor the reflected energy passed by the directional coupler and converted the reflected microwave energy to a voltage. An oscilloscope and a camera were used to record the output voltage of the crystal detector.

The oscilloscope was usually triggered from an ionization switch probe by the detonation. A dielectric rod waveguide (3) was used as a transmission line between the instrumentation and the sample. The dielectric rod waveguide was expendable and acted as a mode selector to launch a pure mode of transmission in the sample. A schematic diagram of the experimental setup is shown in Fig. 2. The standard

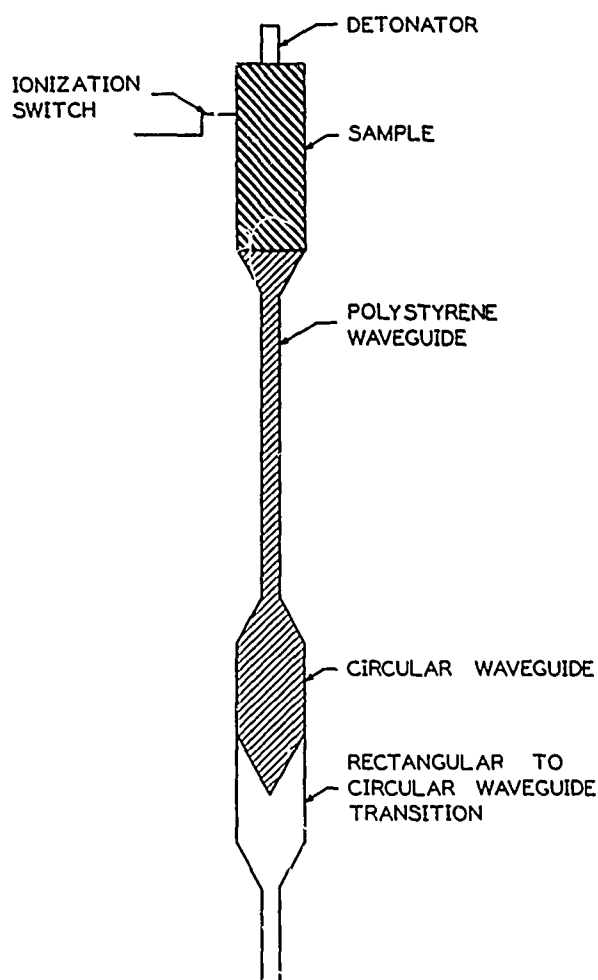

FIG. 2 SCHEMATIC DIAGRAM OF THE EXPERIMENTAL SETUP.

rectangular waveguide from the instrumentation shown in Fig. 1 was converted to circular waveguide by a transition. A polystyrene rod, tapered to a point to reduce reflections, was inserted a short distance into the circular waveguide. The polystyrene rod was then tapered to a smaller diameter rod to reduce losses in transmission and then expanded to the diameter of the sample.

The voltage developed in the crystal detector can be considered as the sum of two reflected microwave signals. One is the sum of all fixed reflections in the transmission line and is of constant phase. The other is the reflection from the shock front and goes through a 2π phase shift for each displacement of the front by a half wavelength of the microwaves. Thus the voltage from the crystal detector goes through a maximum and minimum for each displacement of the shock front by a half wavelength.

In terms of the Doppler effect, the frequency of the voltage from the crystal detector can be considered as the Doppler shift in frequency f_d given by

$$f_d = \frac{2vf}{c}$$

where v is the velocity of the reflecting shock front, f is the microwave frequency and c is the velocity of propagation of the microwaves in the medium through which the shock travels.

The wavelength of the microwaves in the sample was usually determined by observing the number of peaks in the voltage from the crystal detector as the shock front traversed a sample of known length. When multiple modes of propagation were present in the sample, the voltage from the crystal detector appeared modulated because the modes had different wavelengths.

GROWTH TO DETONATION IN AMMONIUM PERCHLORATE

The explosive used in this investigation was 68 μ median particle size ammonium perchlorate. The charges were hand packed to a density of 1.31 gm/cm³ in 2-inch O.D. glass tubes having a wall thickness of 0.08 inches. The donor charge was two (50/50) pentolite pellets 2 inches in diameter and 1 inch long. The acceptor charge was 8 inches long. The card gaps were made of 2-inch disks of Plexiglas^{®1}.

X-band microwave equipment was used and measurements were made at a frequency of 9.903 Gc/sec. The charge was initiated by J-2 electric blasting cap (4). The oscilloscope was triggered when the detonation front in the donor charge reached the ionization switch probe, which had been placed between the two pentolite charges. The oscilloscope recorded the displacement of the detonation front in the last inch of the donor charge, the displacement of the shock wave in the Plexiglas gap, and the growth of the detonation in the acceptor charge.

The microwave wavelength was determined in the charge of explosive by observing the number of wavelengths traversed by a detonation front as it moved through a charge of known length. Using acceptors of measured length and no gap between the donor and the acceptor, the number of wavelengths traversed were counted on the oscilloscope trace. The location of the interface between the donor and the acceptor was not apparent from the oscilloscope trace. The location of this interface was determined by measuring from streak camera photographs the time required for the detonation front in pentolite to travel through the last inch of the donor charge. A wavelength of 16.6 mm at 9.930 Gc/sec was determined from two shots.

A photograph of an oscilloscope trace is shown in Fig. 3 for a gap of 1.596 inches of Plexiglas. An oscilloscope with a faster sweep was used to obtain a longer time base. The sweep starts in the lower

¹Trademark for thermoplastic poly(methyl methacrylate)-type polymers, Rohm & Haas Company, Philadelphia, Pennsylvania.

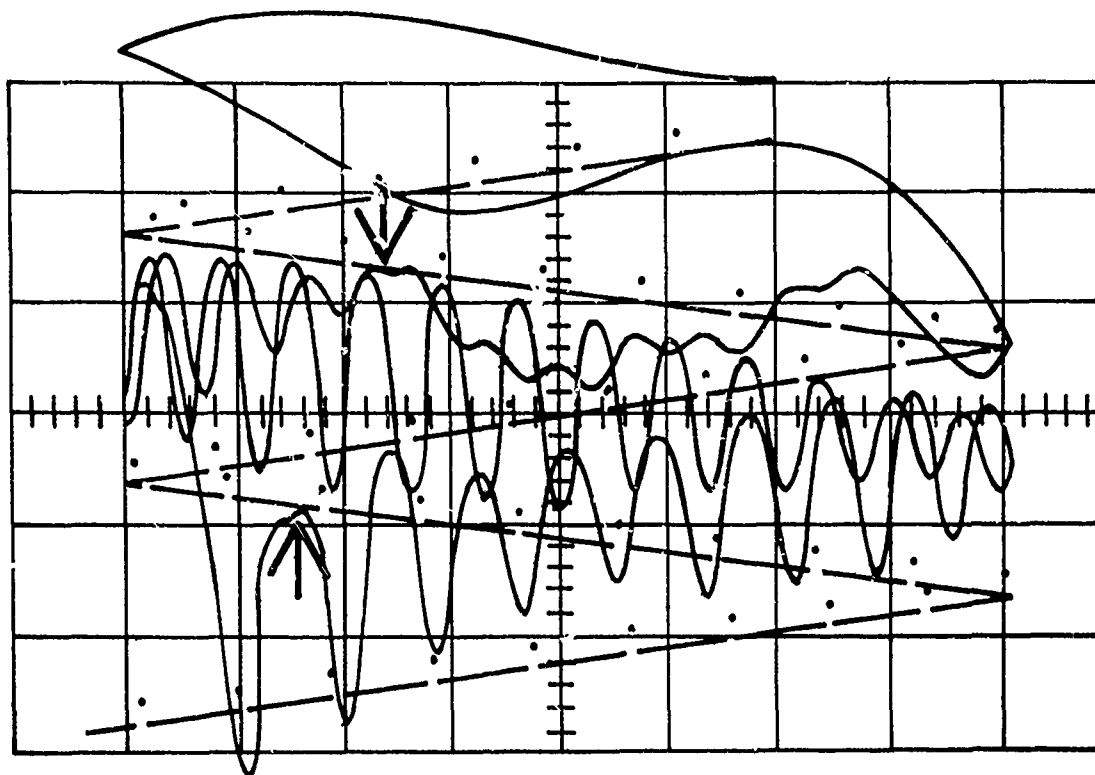

FIG. 3 OSCILLOGRAM OF GROWTH TO DETONATION IN AMMONIUM PERCHLORATE.

left hand corner and sweeps back and forth across the face of the tube. A timing signal with $5\mu\text{sec}$ time marks was first recorded on the film. The beginning and the end of the signal from the acceptor charge are marked by arrows on the trace. Fig. 4 is the displacement-time curves for 3 charges. The interface between the donor and acceptor or the Plexiglas and the acceptor was used as a reference point and displacements were measured from it. Curve 1 of Fig. 4 shows an initial reaction moving at less than the steady state detonation velocity. Curve 3, with no gap shows an initial velocity much greater than the

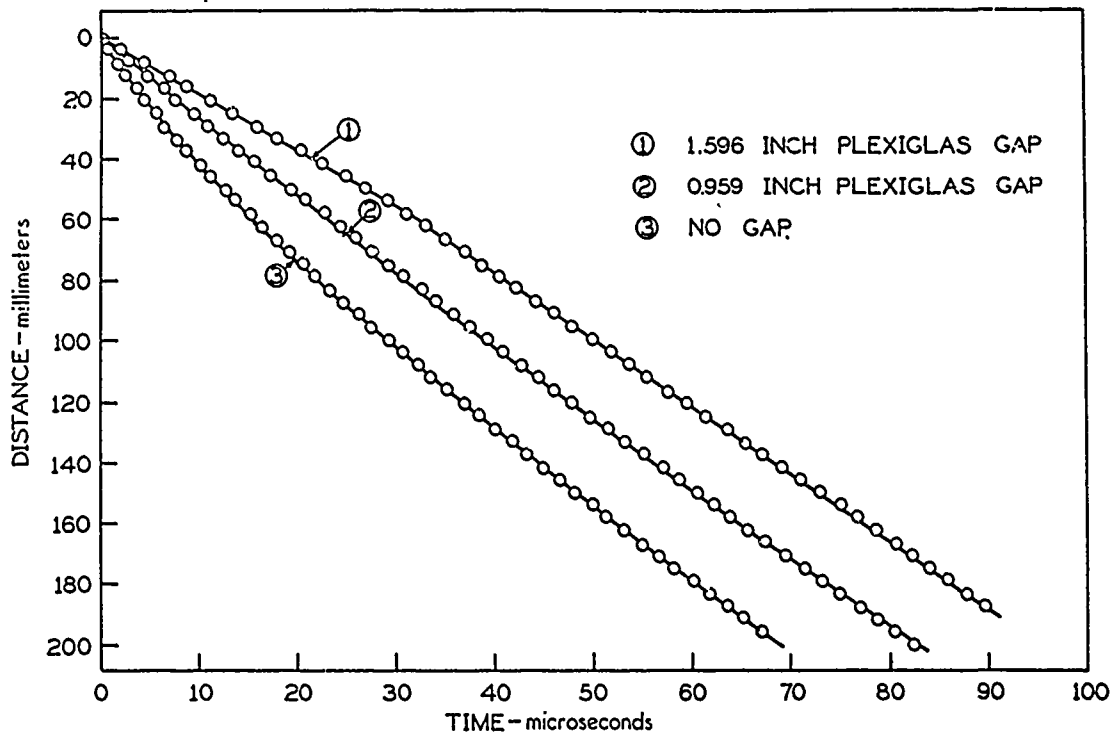

FIG. 4 DISPLACEMENT-TIME CURVES OF GROWTH TO DETONATION IN AMMONIUM PERCHLORATE.

detonation velocity. Fig. 5 shows the velocity-distance curves for 4 charges with increasing gap thickness, from no gap to a gap of 1.808 inches which failed to detonate (a large amount of ammonium perchlorate was found in the detonation bay after the shot was fired). The velocities were determined by taking the average velocity of the detonation between peaks of the recorded signal.

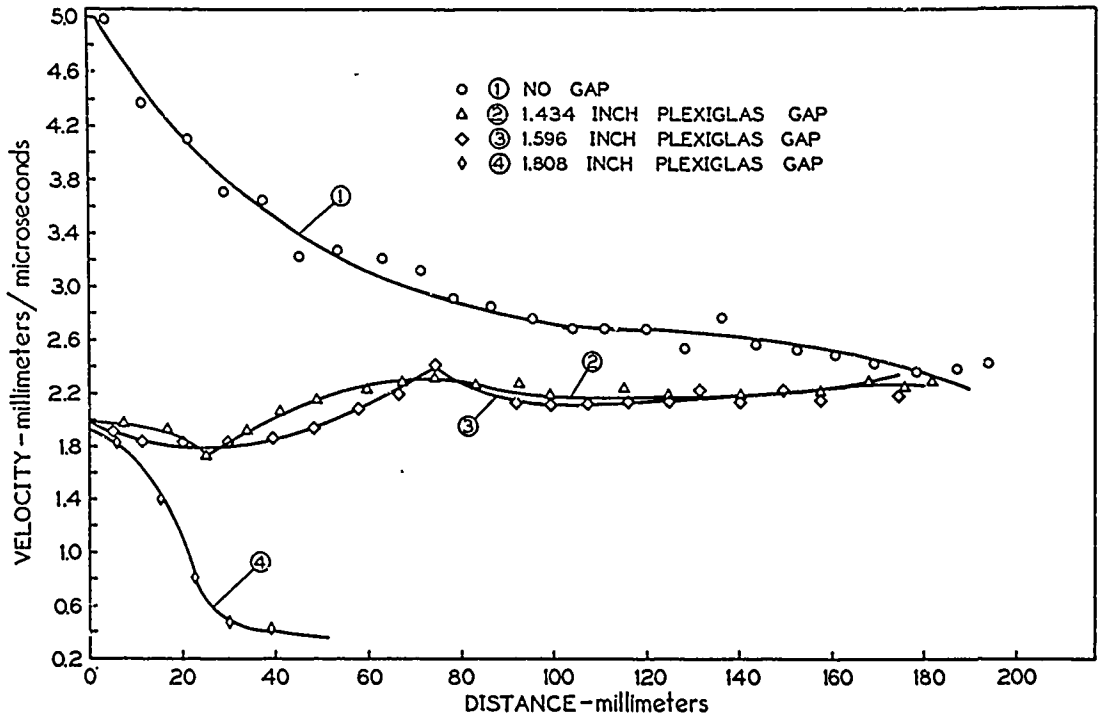

FIG. 5 VELOCITY-DISTANCE CURVES OF GROWTH TO DETONATION IN AMMONIUM PERCHLORATE.

GROWTH TO DETONATION IN COMPOSITION C-4¹

The explosive used in this investigation was Composition C-4. The charges were hand packed to a density of 1.59 gm/cm^3 in cardboard tubes having a wall thickness of 0.01 inches. The donor charge was 1 inch in diameter and 3 inches long. The acceptor charge was 1 inch in diameter and 4 inches long. The card gaps were made up of 1-inch disks of Plexiglas having a total thickness of approximately 0.8 inches. K-band microwave equipment was used and measurements were made at a frequency of 24 Gc/sec. The charge was initiated by a No. 8 electrical blasting cap. The oscilloscope was triggered when the detonation front in the donor charge reached the ionization switch probe, which had been placed 1 inch from the base of the charge. The oscilloscope recorded the displacement of the detonation front in the last inch of the donor charge, the displacement of the shock wave in the Plexiglas gap, and the growth of detonation in the acceptor charge.

The microwave wavelength was determined in the charge of explosive by observing the number of wavelengths traversed by a detonation front as it moved through a charge of known length. Using acceptors of measured length and a thin sheet of aluminum foil between the donor and the acceptor, the number of wavelengths traversed was counted on the oscilloscope trace. A wavelength of $7.08^{+0.04}_{-0.08}$ mm at 24 Gc/sec. was determined from three such shots. For 1-inch diameter rods of Plexiglas having a dielectric constant (5) of 2.65, a wavelength of 7.88 mm was calculated (6) for the dominant hybrid mode at 24 Gc/sec.

A photograph of a typical oscilloscope trace having a sweep rate of $5 \mu\text{sec/cm}$, is shown in Fig. 6. The trace is divided into three parts (a) the last inch of the donor charge, (b) the Plexiglas gap, and (c) the acceptor charge. From the oscilloscope trace, the time at which the

¹This section has been submitted to the AIAA Journal for publication.

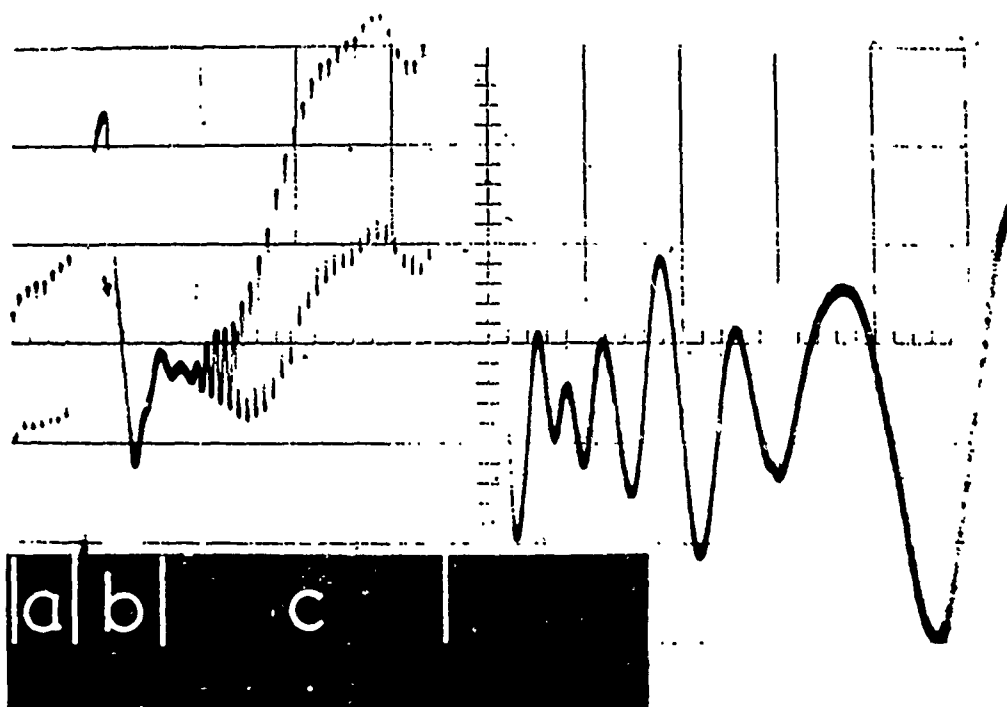

FIG. 6 OSCILLOGRAM OF GROWTH TO DETONATION IN COMPOSITION C-4.

detonation front reached the base of the donor and the acceptor charge is easily determined. However, the time at which the shock front reached the end of the Plexiglas and entered the acceptor charge is not apparent. The progress of the shock wave through the Plexiglas gap could not be determined accurately because the shock front was partially transparent to the microwaves. The fracture front, moving at a lower velocity behind the shock front, produced a large reflection. The reflections from the shock and fracture fronts were superimposed to complicate the trace. This same complication was observed in the acceptor charge of the shots that failed to reach detonation. The front in the C-4 seemed to be partially transparent and other reflections complicated the trace. This complication was not observed in shots that reached detonation since the front in an acceptor charge that reached detonation was a reactive front and reflected more energy.

The location of the interface between the Plexiglas and the acceptor was determined by measuring from streak camera photographs (7) the time required for a shockwave from a 1-inch diameter charge of Composition C-4 to travel through 0.80 inches of Plexiglas; this was 4.8 μ sec. The position of the interface between the Plexiglas and the acceptor, determined by the above method, was checked by accounting for the number of wavelengths that would be present from an acceptor of known length. In all cases this check was within the accuracy of the determination of the wavelength.

Fig. 7 is the displacement-time curve reduced from the oscilloscope trace shown in Fig. 5. The interface between the Plexiglas

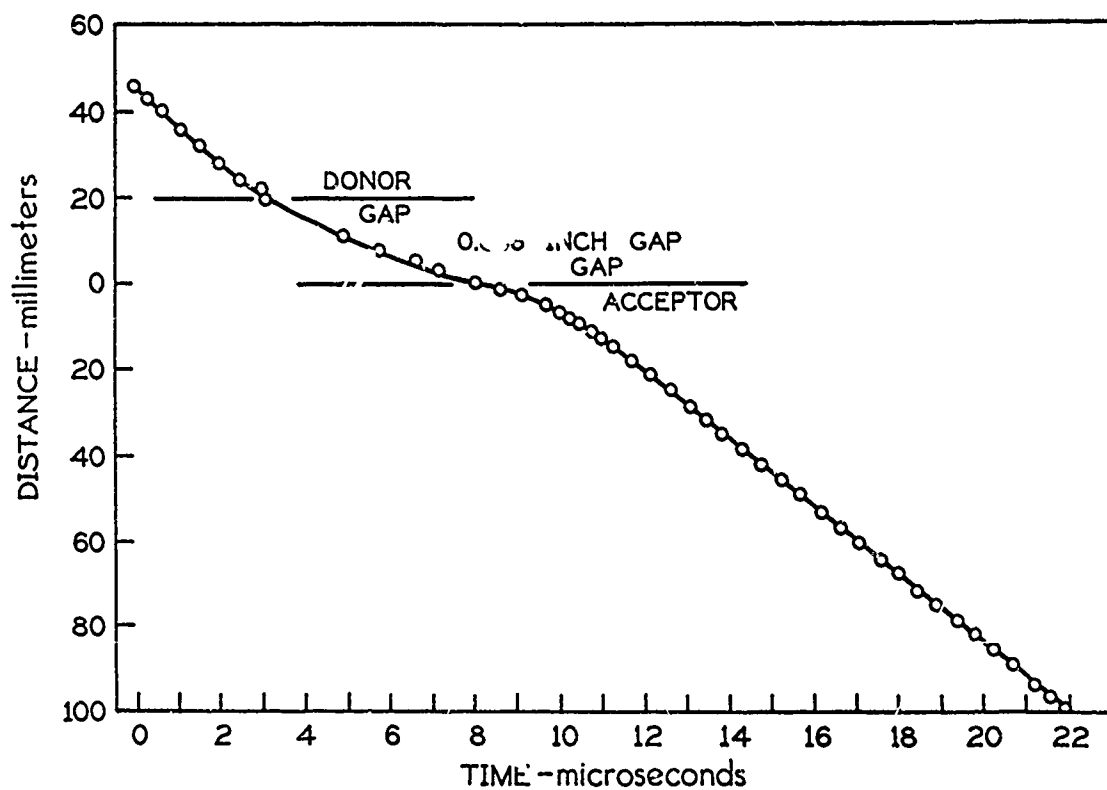

FIG. 7 DISPLACEMENT-TIME CURVE FROM THE OSCILLOGRAM IN FIG. 6.

and the acceptor was arbitrarily taken as a reference point and displacements were measured from it. Fig. 8 shows the displacement-time curves of the growth to detonation at other gap thicknesses near the 50% card gap. Table I shows data taken from 10 shots. The first and last shots were well below and above the 50% card gap value while the remaining shots were near the 50% card gap value. The velocities reported in Table I were determined graphically as the slopes of smooth curves through the data points. The accuracy of the data obtained in the Plexiglas gap was not good enough to show any real differences between shock wave velocities that reached detonation and those that failed to reach detonation.

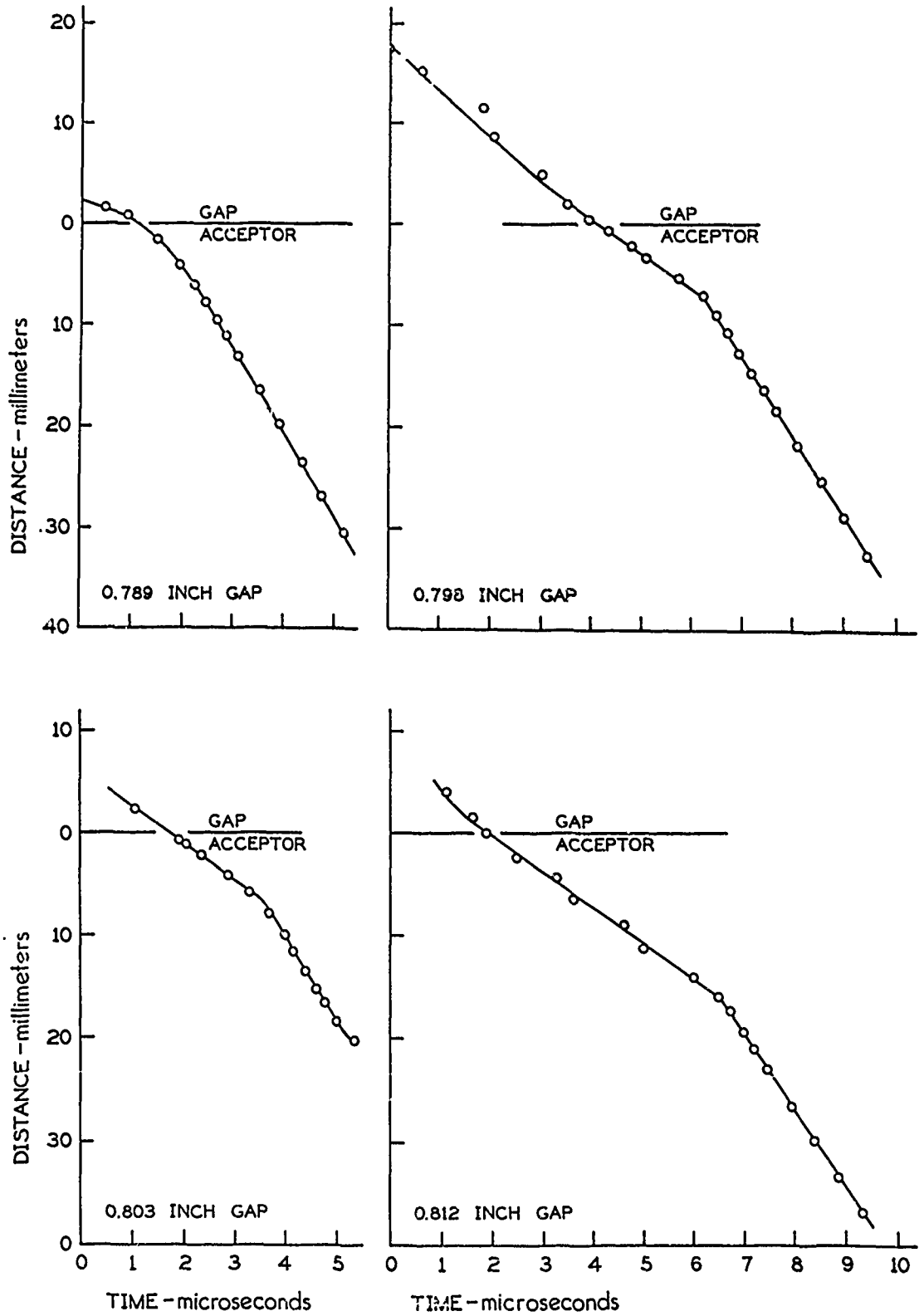

FIG. 8 GROWTH TO DETONATION FOR SEVERAL GAP THICKNESSES.

Table I

Summary of Results

<u>Plexiglas gap inches</u>	<u>Time to Detonation μsec</u>	<u>Distance to Detonation mm</u>	<u>Final Velocity in Plexiglas mm/μsec</u>	<u>Initial Velocity in Acceptor mm/μsec</u>
0.734	<0.4	<4.0	a	a
0.789	1.6	10.0	a	a
0.798	2.5	8.8	3.8	3.4
0.803	1.6	5.7	a	3.5
0.806	1.8	6.0	3.8	3.3
0.808	FAILED TO DETONATE		3.8	3.8
0.812	4.4	15.0	3.9	3.5
0.820	FAILED TO DETONATE		3.9	4.0
0.833	FAILED TO DETONATE		3.9	4.0
1.003	FAILED TO DETONATE		3.3	3.3

^aVelocities could not be determined.

DETONATION OF PENTOLITE

The explosive used in this investigation was (50/50) Pentolite. The charge consisted of six 2-inch diameter by 1-inch long pentolite pellets of average density 1.555 gm/cm^3 . K-band microwave equipment was used and measurements were made at a frequency of 20 Gc/sec. The charge was initiated by a J-2 electric blasting cap (8). The oscilloscope was triggered by an ionization switch probe on top of the charge beside the blasting cap or from a signal from the streak camera 15 to 20 μsec before the initiation of detonation.

The microwave wavelength was determined by observing the number of wavelengths traversed by the detonation front as it moved through the 6 inch charge. A wavelength of $4.56^{+0.06}_{-0.10}$ mm at 20,000 Gc/sec was determined from 4 shots. A photograph of an oscilloscope trace is shown in Fig. 9. A timing signal with 1 μsec time

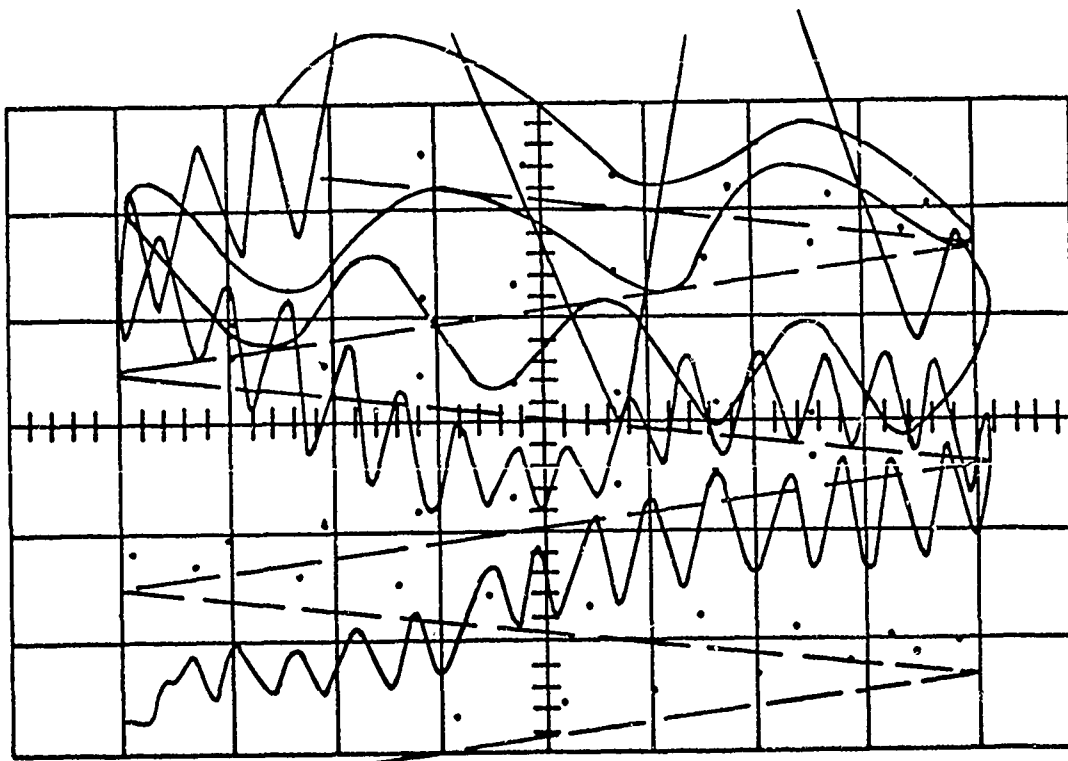

FIG. 9 OSCILLOGRAM OF DETONATION IN PENTOLITE.

marks was first recorded on the film. The oscilloscope was triggered by an ionization switch on top of the charge and was delayed about a microsecond from the initiation of the detonation. Fig. 10 shows the

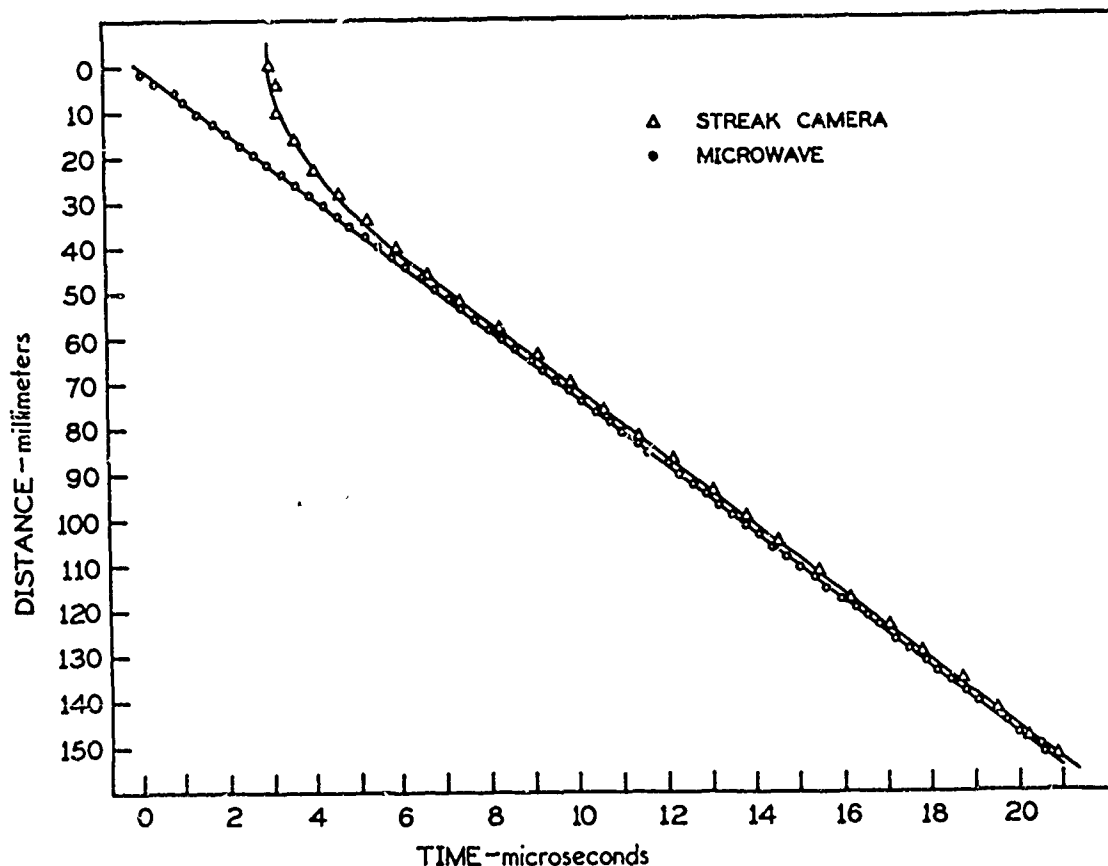

FIG. 10 DISPLACEMENT-TIME CURVES OF DETONATION IN PENTOLITE.

simultaneous microwave interferometry and streak camera determination of the displacement-time curves of a shot. The detonation velocity, determined by a least squares fit of the microwave interferometry data to a straight line, is 7.36 mm/ μ sec. The detonation velocity determined by the slope of the streak camera photograph for the last 4 inches of the charge is 7.43 mm/ μ sec. Table II shows the values of detonation velocity determined by the above methods from six shots with microwave

Table II
Detonation Velocity of Pentolite

<u>Microwave Interferometry</u> mm/μsec	<u>Streak Camera</u> mm/μsec
7.30	7.08
7.32	7.25
7.32	7.43
7.32	7.57
7.34	7.67
7.36	Average 7.40
Average <u>7.33</u>	

interferometry and from 5 shots with the streak camera. The average velocity determined by microwave interferometry is 7.33 and by the streak camera is 7.40 mm/μsec. Considering the possible error in determining the wavelength of the microwaves in the charge, the average value determined by microwave interferometry would be $7.33^{+0.10}_{-0.15}$ mm/μsec. A previously determined value (9) for a density of 1.549 gm/cm³ is 7.27 mm/μsec.

Fig. 11 shows the velocity-distance curves for 4 shots determined by microwave interferometry. The velocities were determined by taking the average velocity of detonation between peaks of the recorded signal. The variation of the velocity from a constant value toward the end of each charge is almost surely due to a small amount of the microwave energy propagating in a second mode and can be observed in Fig. 9 by the decrease in amplitude and a change in level of the recorded signal.

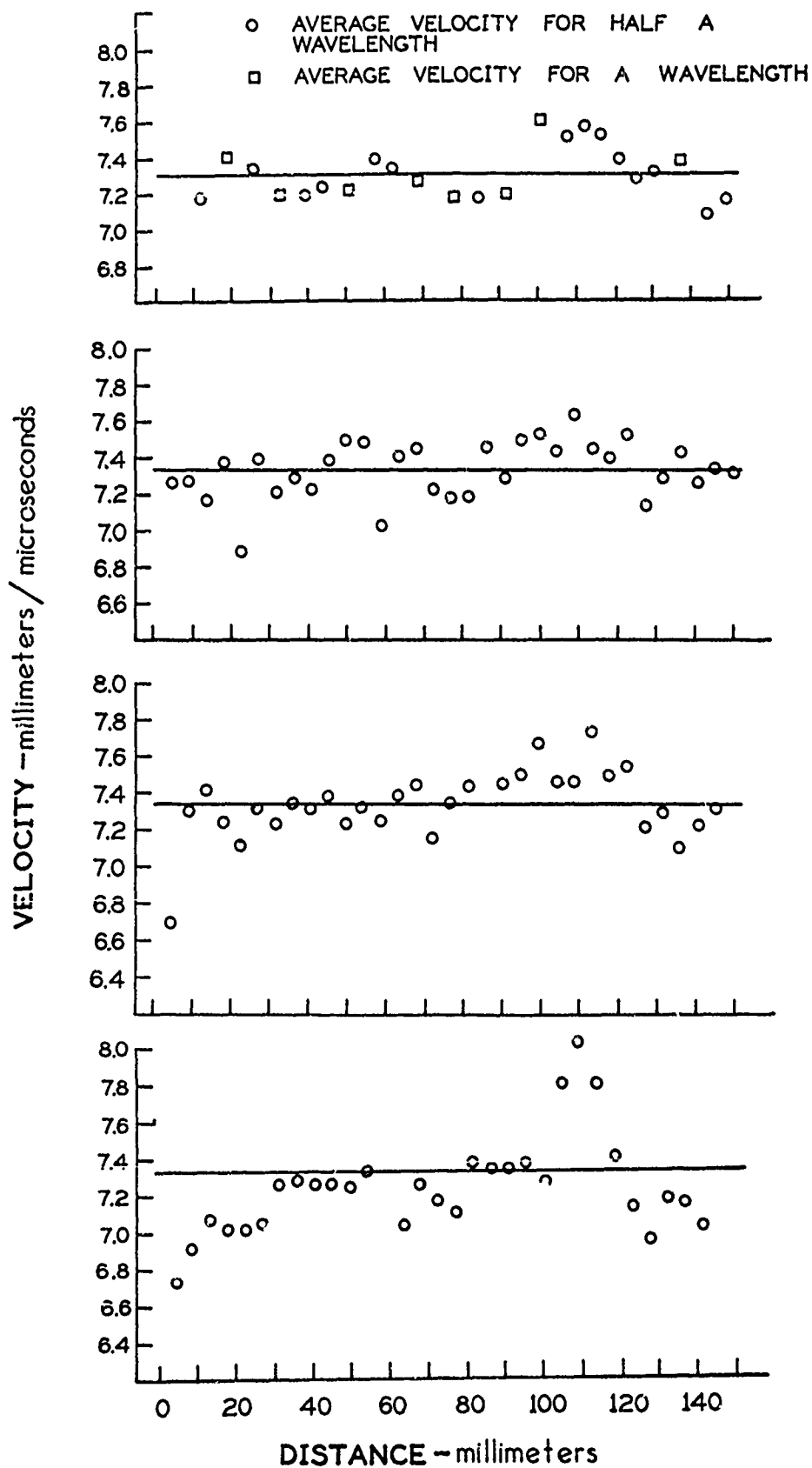

FIG. 11 VELOCITY-DISTANCE CURVES OF DETONATION IN PENTOLITE.

CONCLUSION

Microwave interferometry has been used to observe the growth to detonation of Composition C-4. The results confirm the information on growth to detonation of high explosives obtained from streak camera photographs of wedge shaped charges covered with a thin reflecting film (10). The microwave interferometry technique has been used to observe the growth to detonation of a porous, low density charge of ammonium perchlorate. The results have confirmed a detonation where the usual witness plate technique was doubtful. This technique has been able to give detonation velocities of comparable accuracy with streak camera photographs, and certainly relates information from the interior of the charge and not just information from the lateral surface as usually obtained from streak camera photographs.

The instrumentation set up and data reduction are relatively simple and easily performed. The only expendables involved are the film for the oscilloscope camera and the polystyrene rod waveguide. This method should be most useful in studying accelerating and decelerating shock fronts. The accuracy of the technique can be improved by using longer samples to determine the microwave wavelength since this determination is the largest source of error in the technique.

The problem of launching a pure mode is not completely solved for large samples (diameter and length). A pure mode could not be launched in a 2-inch diameter by 6-inch long charge at 24 Gc/sec. No attempts have been made to launch a pure mode in cylindrical samples larger than 2 inches in diameter. A pure mode has been launched into samples (under 4 inches long) with 4-inch square cross section. A small diameter polystyrene rod waveguide was simply placed against the base of the sample, which was then treated as an infinite dielectric medium.

REFERENCES

1. Cook, M. A., Doran, R. L., and Morris, G. J., "Measurement of Detonation Velocity by Doppler Effects at Three-Centimeter Wavelength," J. Appl. Phys., 26, 426-428 (1955).
2. Cawsey, G. F., Farrands, J. L., and Thomas, S., "Observations of Detonation in Solid Explosive by Microwave Interferometry," Proc. Roy. Soc. (London) 248, Series A, 499-521 (1958).
3. Chandler, C. H., "An Investigation of Dielectric Rod as Wave Guide," J. Appl. Phys., 20, 1188-1192 (1949).
4. Hercules Powder Company, Wilmington, Delaware.
5. Techniques of Microwave Measurements, Edited by Carol G. Montgomery, (McGraw-Hill Book Company, Inc., New York, 1947) 1st ed., Chap. 10, pp. 666.
6. Elsasser, W. M., "Attenuation in a Dielectric Circular Rod," J. Appl. Phys. 20, 1193-1196 (1949).
7. Unpublished data obtained by Dr. T. H. Pratt at Rohm & Haas Company, Huntsville, Alabama.
8. Hercules Powder Company, Wilmington, Delaware.
9. Wise, Leo S., "Study Fundamental Properties of High Explosives," Technical Report No. 1466, Picatinny Arsenal, 3 January 1945.
10. Campbell, A. W., Davis, W. C., Ransay, J. B., and Travis, J. R., "Shock Initiation of Solid Explosives," Phys. Fluids, 4, 511-521 (1961).

Initial distribution of this report was made in accordance with the CPIA mailing list for chemical propulsion technical information plus approved supplements