

UNCLASSIFIED

AD NUMBER

AD466166

LIMITATION CHANGES

TO:

Approved for public release; distribution is unlimited.

FROM:

Distribution authorized to U.S. Gov't. agencies and their contractors;  
Administrative/Operational Use; JUL 1965. Other requests shall be referred to Air Force Flight Dynamics Laboratory, Wright-Patterson AFB, OH 45433.

AUTHORITY

aedc ltr, 12 nov 1965

THIS PAGE IS UNCLASSIFIED



**AN INVESTIGATION OF THE EFFECTS OF  
SHOCK IMPINGEMENT ON A BLUNT LEADING EDGE**

**A. D. Ray and R. L. Palko**

**ARO, Inc.**

**July 1965**

**VON KÁRMÁN GAS DYNAMICS FACILITY  
ARNOLD ENGINEERING DEVELOPMENT CENTER  
AIR FORCE SYSTEMS COMMAND  
ARNOLD AIR FORCE STATION, TENNESSEE**

# *NOTICES*

When U. S. Government drawings specifications, or other data are used for any purpose other than a definitely related Government procurement operation, the Government thereby incurs no responsibility nor any obligation whatsoever, and the fact that the Government may have formulated, furnished, or in any way supplied the said drawings, specifications, or other data, is not to be regarded by implication or otherwise, or in any manner licensing the holder or any other person or corporation, or conveying any rights or permission to manufacture, use, or sell any patented invention that may in any way be related thereto.

Qualified users may obtain copies of this report from the Defense Documentation Center.

References to named commercial products in this report are not to be considered in any sense as an endorsement of the product by the United States Air Force or the Government.

AN INVESTIGATION OF THE EFFECTS OF  
SHOCK IMPINGEMENT ON A BLUNT LEADING EDGE

A. D. Ray and R. L. Palko  
ARO, Inc.

## FOREWORD

The results presented are for tests conducted at the request of the Air Force Flight Dynamics Laboratory (AFFDL), Air Force Systems Command (AFSC), under Program Element 62405334, Project 1336, Task 136607.

The results of the tests were obtained by ARO, Inc. (a subsidiary of Sverdrup and Parcel, Inc.), contract operator of the Arnold Engineering Development Center (AEDC), AFSC, Arnold Air Force Station, Tennessee, under Contract AF 40(600)-1000. The tests were conducted from December 5, 1963 to April 22, 1965 under ARO Project Number VT0424, and the report was submitted by the authors on June 24, 1965.

This technical report has been reviewed and is approved.

Darreld K. Calkins  
Major, USAF  
AF Representative, VKF  
DCS/Test

Jean A. Jack  
Colonel, USAF  
DCS/Test

**ABSTRACT**

Tests were conducted at hypersonic Mach numbers on a blunt leading edge model both with and without an impinging shock. The effects of Reynolds number, Mach number, leading edge sweep angle, and impinging shock strength on the temperature and pressure distribution for the leading edge were determined. The tests were conducted at nominal Mach numbers of 6, 8, and 10 at unit Reynolds numbers of  $0.58 \times 10^6$  to  $3.55 \times 10^6$  per foot with a sweep angle range of 0 to 75 deg. Selected results which show the effect of shock generator angle and sweep angle at Mach 6 and 10 are presented.

## CONTENTS

	<u>Page</u>
ABSTRACT . . . . .	iii
NOMENCLATURE . . . . .	vi
I. INTRODUCTION . . . . .	1
II. APPARATUS	
2.1 Wind Tunnels . . . . .	1
2.2 Model and Support . . . . .	2
2.3 Instrumentation . . . . .	2
III. PROCEDURE	
3.1 Test Conditions . . . . .	3
3.2 Data Reduction. . . . .	4
IV. RESULTS AND DISCUSSION . . . . .	5
REFERENCES. . . . .	6

## ILLUSTRATIONS

Figure

1. Wind Tunnels . . . . .	7
2. Model Details	
a. Leading Edge with Blunt Nose . . . . .	8
b. Leading Edge with Shock Generator . . . . .	9
3. Model Installation Photographs	
a. Blunt Nose Model in Tunnel B . . . . .	10
b. Shock Generator Model in Tunnel C, Retracted . . . . .	11
4. Leading Edge Stagnation Line Shock Impingement Effects at Mach 6	
a. Pressure . . . . .	12
b. Heat Transfer . . . . .	13
5. Leading Edge Stagnation Line Shock Impingement Effects at Mach 10	
a. Pressure . . . . .	14
b. Heat Transfer . . . . .	15
6. Shadowgraph of Shock Impingement Region, $M_\infty = 6$ , $Re_\infty/ft = 1.0 \times 10^6$	
a. Separated Flow ( $\Lambda = 20$ deg) . . . . .	16
b. Attached Flow ( $\Lambda = 30$ deg) . . . . .	17

## NOMENCLATURE

b	Model skin thickness, ft
c	Model skin material specific heat, Btu/lb °R
h	Heat-transfer coefficient, Btu/ft <sup>2</sup> sec °R
$M_{\infty}$	Free-stream Mach number
p	Pressure, psi
Q	Aerodynamic heat-transfer rate, Btu/ft <sup>2</sup> sec
$Re_{\infty}$	Free-stream Reynolds number
r	Recovery factor
T	Temperature, °R
t	Time, sec
w	Specific weight of model material, lb/ft <sup>3</sup>
x	Distance along leading edge, in.
$\alpha_L$	Local angle of attack, deg
$\gamma$	Ratio of specific heats
$\delta$	Angle between generator surface and free-stream flow, deg
$\theta$	Shock generator angle, deg
$\Lambda$	Sweep angle, deg
$\omega$	Angular location of instrumentation around leading edge ( $\omega = 90$ deg at stagnation line), deg

## SUBSCRIPTS

aw	Adiabatic wall
m	Model surface
NS	Leading edge without shock impingement
o	Stagnation
S	Leading edge with shock impingement



## SECTION I INTRODUCTION

Heat-transfer and pressure distribution tests were conducted on a 1-in. -radius leading edge to determine the effects of an impinging shock generated by an attached wedge. The influence of Mach number, Reynolds number, leading edge sweep angle, and impinging shock strength were studied. The tests were conducted in cooperation with the Air Force Flight Dynamics Laboratory (AFFDL), Research and Technology Division (RTD), Air Force Systems Command (AFSC). The tests were performed in the 50-in. hypersonic tunnels (Gas Dynamic Wind Tunnels, Hypersonic (B) and (C)) at nominal Mach numbers of 6, 8, and 10 with free-stream unit Reynolds numbers of  $0.58 \times 10^6$  to  $3.55 \times 10^6$  per foot. The angle of the shock generator with respect to the leading edge was varied from 90 to 150 deg, and the sweep angle of the leading edge was varied from 0 to 75 deg.

## SECTION II APPARATUS

### 2.1 WIND TUNNELS

#### 2.1.1 Tunnel B

Tunnel B is a Mach 6 or 8, axisymmetric, continuous flow, variable density wind tunnel with a 50-in. -diam test section. Because of changes in boundary-layer thickness caused by changing pressure level, the contoured nozzle produces an average test section Mach number which varies from 5.93 at a stagnation pressure of 25 psia to 6.06 at a stagnation pressure of 200 psia for the Mach 6 nozzle and 8.0 at a stagnation pressure of 100 psia to 8.1 at a stagnation pressure of 800 psia for the Mach 8 nozzle.

#### 2.1.2 Tunnel C

Tunnel C is a Mach 10, axisymmetric, continuous flow, variable density wind tunnel with a 50-in. -diam test section. Because of changes in the boundary-layer thickness caused by changing pressure levels, the contoured nozzle produces an average test section Mach number which varies from 10.0 at a stagnation pressure of 200 psia to 10.2 at a stagnation pressure of 2000 psia.

An unusual feature of the tunnels is the model installation chamber below the test section which allows the entire pitch mechanism, sting, and model to be lowered out of the tunnel. When the model is in the retracted position, the fairing doors and the safety doors can be closed, and the tank can be entered for model changes while the tunnel is running.

### **2.1.3 Air Supply System**

The tunnels are served by the VKF 92, 500-hp compressor system. To prevent liquefaction of the air in the test sections, a propane-fired heater capable of heating the air to 1360°R is used for Tunnel B, and the propane-fired heater and a 12, 000-kw electric heater are used in combination to produce air temperatures of 1900°R for Tunnel C. Details of the tunnels are shown in Fig. 1, and a more complete description is given in Ref. 1.

## **2.2 MODEL AND SUPPORT**

Two 1-in. -radius leading edge models were supplied by AFFDL. The pressure model was instrumented with 96 pressure orifices and the thin skin ( $b = 0.05$  in. ) heat-transfer model with 96 Chromel®-Alumel® thermocouples. The instrumentation was placed along the leading edge at 0.5-in. intervals and around the model at every 2-in. interval. Both models could be tested with or without a shock generator (Figs. 2 and 3).

Variation of the leading edge sweep angle was accomplished by using the tunnel pitch mechanism and prebent stings.

## **2.3 INSTRUMENTATION**

### **2.3.1 Pressure Instrumentation**

#### **2.3.1.1 Tunnel B**

The model pressures were measured with nine Wiancko pressure transducers, rated at 5 psid, connected selectively to seven independently variable reference pressures which were constantly monitored by seven CEC Electromanometers, rated at 1, 5, 15, and 30 psia. Three instrument sensitivities, calibrated to obtain full-scale deflection for  $\pm 0.3$ , 0.6, and 1.2 psid, were used with the seven reference pressures, which varied in approximately 2-psid increments from nearly zero pressure. The system automatically selected the proper instrument sensitivity and absolute reference pressure to ensure measurement of the model pressures to the best available precision.

### 2.3.1.2 Tunnel C

This pressure data system is also a nine-channel unit. Each channel includes two pressure measuring transducers (referenced to near vacuum). The two measuring transducers, a  $\pm 1$ -psid unit and a 0- to 15-psid unit, are switched in and out of the system automatically to allow measuring to the best available precision. If the sensed pressure level is above 15 psia, the reference side of the 15-psid transducer is vented to atmosphere to extend the measuring range.

The measuring system is of the Wiancko frequency-modulation type. Precision frequency-modulation oscillators, frequency multipliers, binary counters, and a time base generator operate with the transducers to obtain a differential count of 10,000. The resulting resolution is 0.0002 psi for the 1-psid transducer and 0.0015 psi for the 15-psid transducer. The accumulated count is stored in the binary counters, read out serially by the ERA scanner, and punched on paper tape.

### 2.3.2 Temperature Instrumentation

The reference junction of each thermocouple was maintained at 132°F. Each thermocouple output was recorded in digital form on magnetic tape at the rate of 20 times per second by a Beckman 210 analog-to-digital converter. Selected model temperatures were monitored by nine thermocouple outputs connected to 0.25-sec (full-scale travel) Brown servo-potentiometers.

### 2.3.3 Photographic System

A conventional, short range, divergent ray, spark shadowgraph system was used to obtain pictures of the flow field near the model. Flow patterns on the model surface were recorded with an oil flow technique which utilized a thin layer of Zygl<sup>®</sup> oil illuminated by ultraviolet lamps (Ref. 2).

## SECTION III PROCEDURE

### 3.1 TEST CONDITIONS

The pressure model was injected into the tunnel, and stabilized pressures were recorded at preselected angles of attack.

The heat-transfer model was retracted into the model installation chamber between data groups and cooled to a uniform temperature of approximately 50°F. The cooling of the model was accomplished with room temperature air expanded through side ducts and a nozzle located in the chamber door. The model was then injected at preselected angles of attack, and data were recorded for seven seconds after the model reached the tunnel centerline.

Test conditions are summarized in the following table:

Model Configuration	Data Type	$M_\infty$	$P_{O_2}$ , psia	$T_{O_2}$ , °F	$Re_\infty$ /ft	$\bar{A}$ , deg	$\theta$ , deg
Blunt Nose	Pressure	5.98	44	278	$1 \times 10^6$	0-75	---
	Temperature	5.98	48	320	$1 \times 10^6$	0-75	---
		6.01	100	350	$2 \times 10^6$	0-75	---
		6.05	188	370	$3.55 \times 10^6$	0-75	---
Shock Generator	Pressure	5.98	44	278	$1 \times 10^6$	0-40	0-60
	Temperature	5.98	48	320	$1 \times 10^6$	0-40	0-60
		6.01	100	350	$2 \times 10^6$	0-40	0-60
		6.05	188	370	$3.55 \times 10^6$	0-40	0-60
Blunt Nose	Pressure	10.13	750	1342	$1 \times 10^6$	0-75	---
	Temperature	10.09	400	1270	$0.58 \times 10^6$	0-75	---
		10.13	750	1342	$1 \times 10^6$	0-75	---
		10.18	1650	1426	$2 \times 10^6$	0-75	---
Shock Generator	Pressure	10.13	750	1342	$1 \times 10^6$	0-60	0-60
	Temperature	10.09	400	1270	$0.58 \times 10^6$	0-60	0-60
		10.13	750	1342	$1 \times 10^6$	0-60	0-60
		10.18	1650	1426	$2 \times 10^6$	0-60	0-60

Tests were also conducted at Mach 8. However, since the 0.25-in. shock generator plate was not used in the Mach 8 test, the data are not presented.

### 3.2 DATA REDUCTION

Heat-transfer data were reduced on an IBM 7074 computer using the equation

$$Q = wbc \frac{dT_m}{dt}$$

which neglects radiation and conduction losses. The values of  $dT_m/dt$  were calculated by fitting a least squares parabola to 21 data points (one second of data) centered at one second after the model reached tunnel centerline.

At the request of AFFDL, values of model skin specific heat and density were obtained from Ref. 3 for type 321 stainless steel. The

model skin thickness was provided by AFFDL. The heat-transfer coefficient based on  $T_{aw}$  was calculated by using the equation

$$h = \frac{Q}{T_{aw} - T_m}$$

with

$$T_{aw} = rT_o + (1-r) T_o \left[ \frac{1 + \frac{\gamma - 1}{2} M_\infty^2 \sin^2 \alpha_L}{1 + \frac{\gamma - 1}{2} M_\infty^2} \right]$$

where  $r = 0.85$  and

$$\alpha_L = \sin^{-1} [ \cos \Lambda \sin \omega ]$$

#### SECTION IV RESULTS AND DISCUSSION

Pressure and heat-transfer distributions along the stagnation line of the leading edge are presented in Figs. 4 and 5 for Mach 6 and 10. The pressure and heat-transfer coefficients in the presence of an impinging shock,  $p_S$  and  $h_S$ , have been ratioed to the values,  $p_{NS}$  and  $h_{NS}$ , obtained with the blunt nose configuration without an impinging shock. This eliminates the large sweep effects ( $p_{NS} \sim \cos^2 \Lambda$ ) which could obscure the effects of shock interactions.

The data show the effect of varying leading edge sweep angle on the amplification of local pressure and heat-transfer coefficients resulting from shock interaction for a shock generator angle of 10 deg relative to the free-stream flow direction. Data for other shock generator angles had similar trends. Two distinct types of shock interaction were observed. At both Mach 6 and 10, the boundary layer on the shock generator plate separated when the angle between the plate and the leading edge was less than approximately 120 deg. When this angle was greater than 120 deg no separation was noted. Shadowgraphs showing these two cases are presented in Fig. 6. When the flow on the generator was attached, the maximum pressure on the leading edge was determined by two interacting shocks, consisting of the wedge shock and the leading edge shock. However, when the flow on the generator plate was separated, an additional compression occurred, either isentropically as indicated in Fig. 6a or non-isentropically when the separation was strong enough to produce a shock wave. With a shock generator angle of 10 deg separation existed for sweep angles of 20 deg or less, and the effect of the additional compression is clearly evident by the increased intensity of the pressure and heat

transfer at these angles as shown in Figs. 4 and 5. It is noted that because of the spacing of the instrumentation, the exact shape of the interaction regions could not be determined from the data.

A comparison of Figs. 4 and 5 indicates that as Mach number is increased, the shock induced pressures and heat-transfer rates increase in magnitude but occur over a smaller region on the leading edge.

#### REFERENCES

1. Test Facilities Handbook, (5th Edition). "von Kármán Gas Dynamics Facility, Vol. 4." Arnold Engineering Development Center, July 1963.
2. Rhudy, R. W. "Flow Visualization Techniques for Use in Hypersonic Wind Tunnels." AEDC-TDR-64-108 (AD448116), October 1964.
3. Metals Handbook. American Society for Metals, 1948.

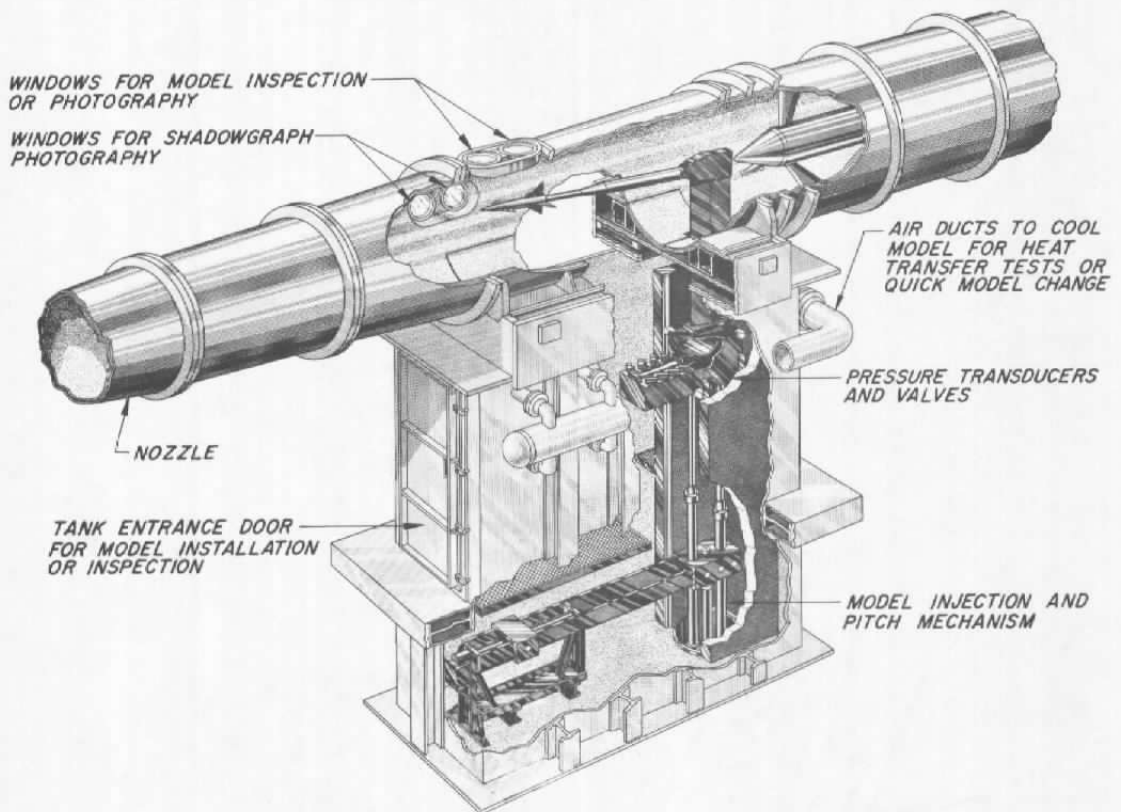
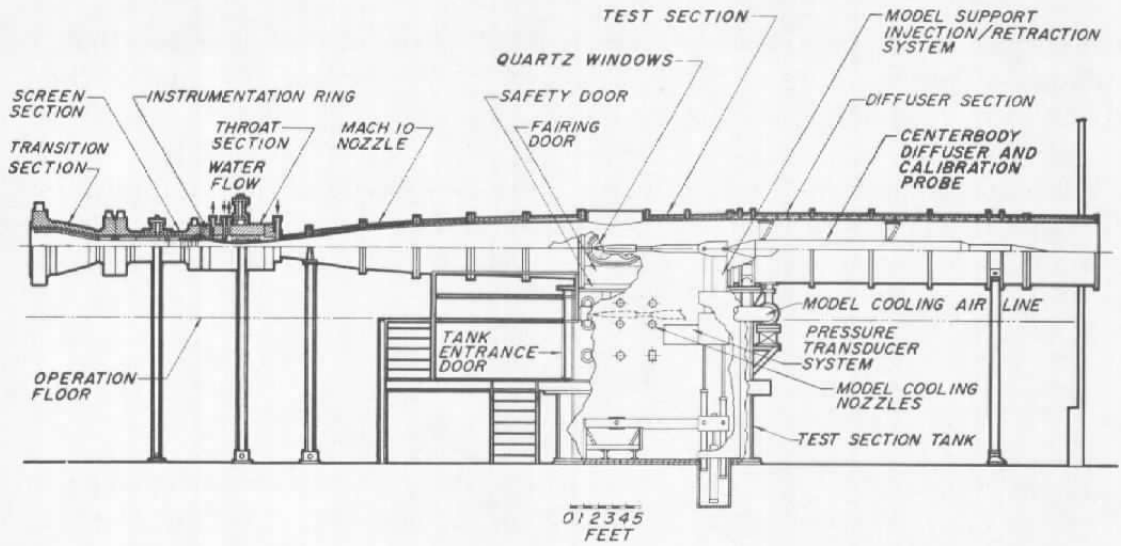
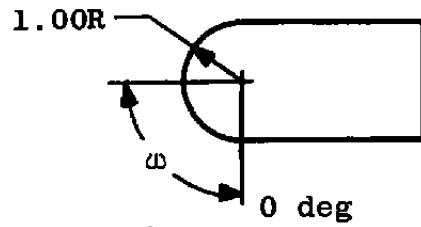
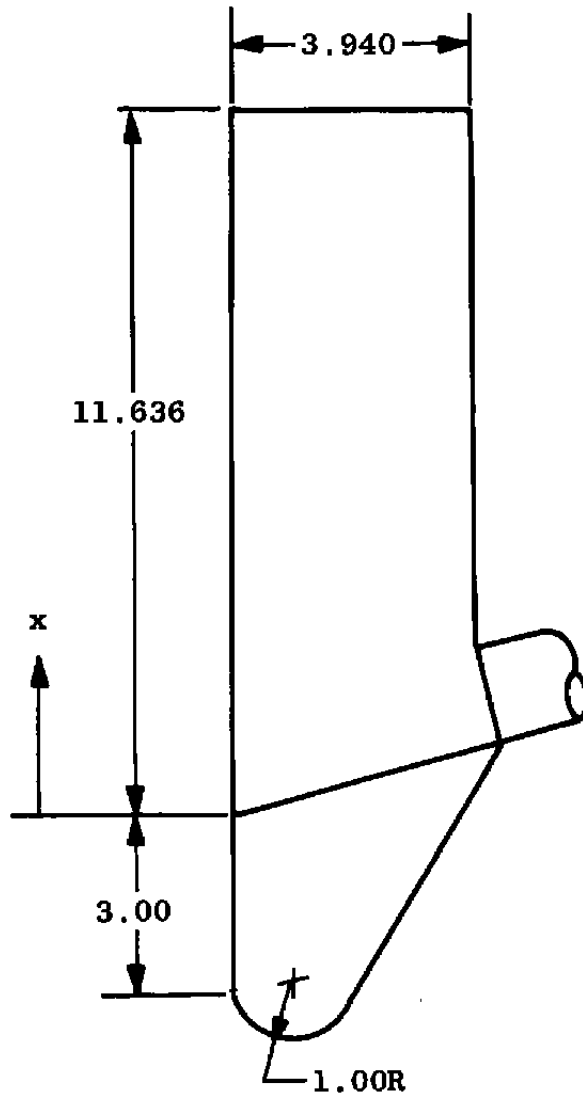

Fig. 1 Wind Tunnels



All Dimensions in Inches



c. Leading Edge with Blunt Nose

Fig. 2 Model Details



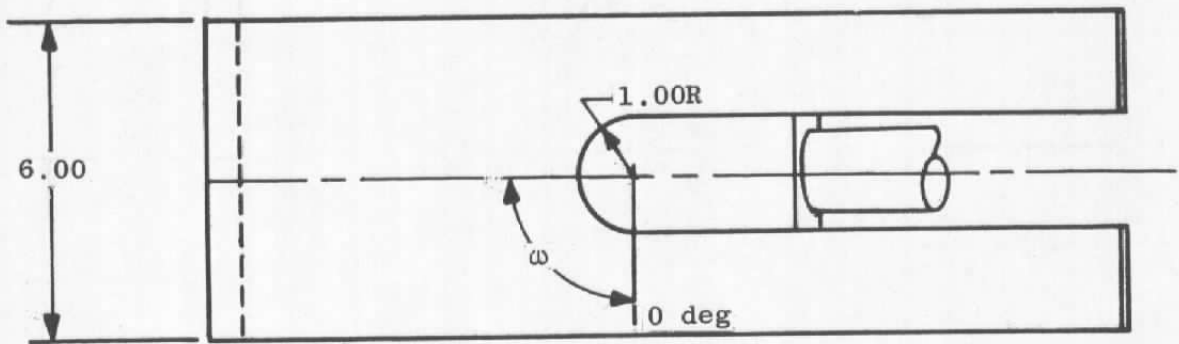

All Dimensions in Inches

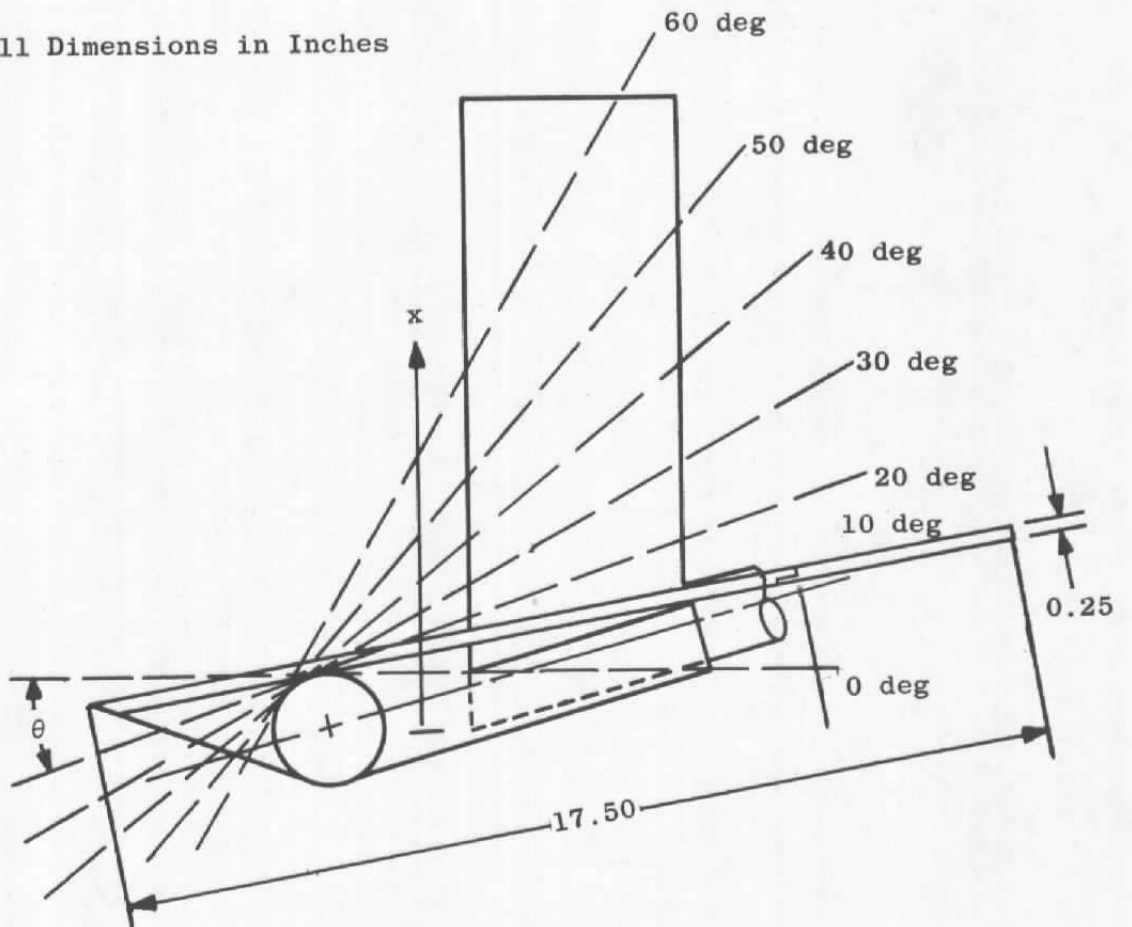

b. Leading Edge with Shock Generator

Fig. 2 Concluded

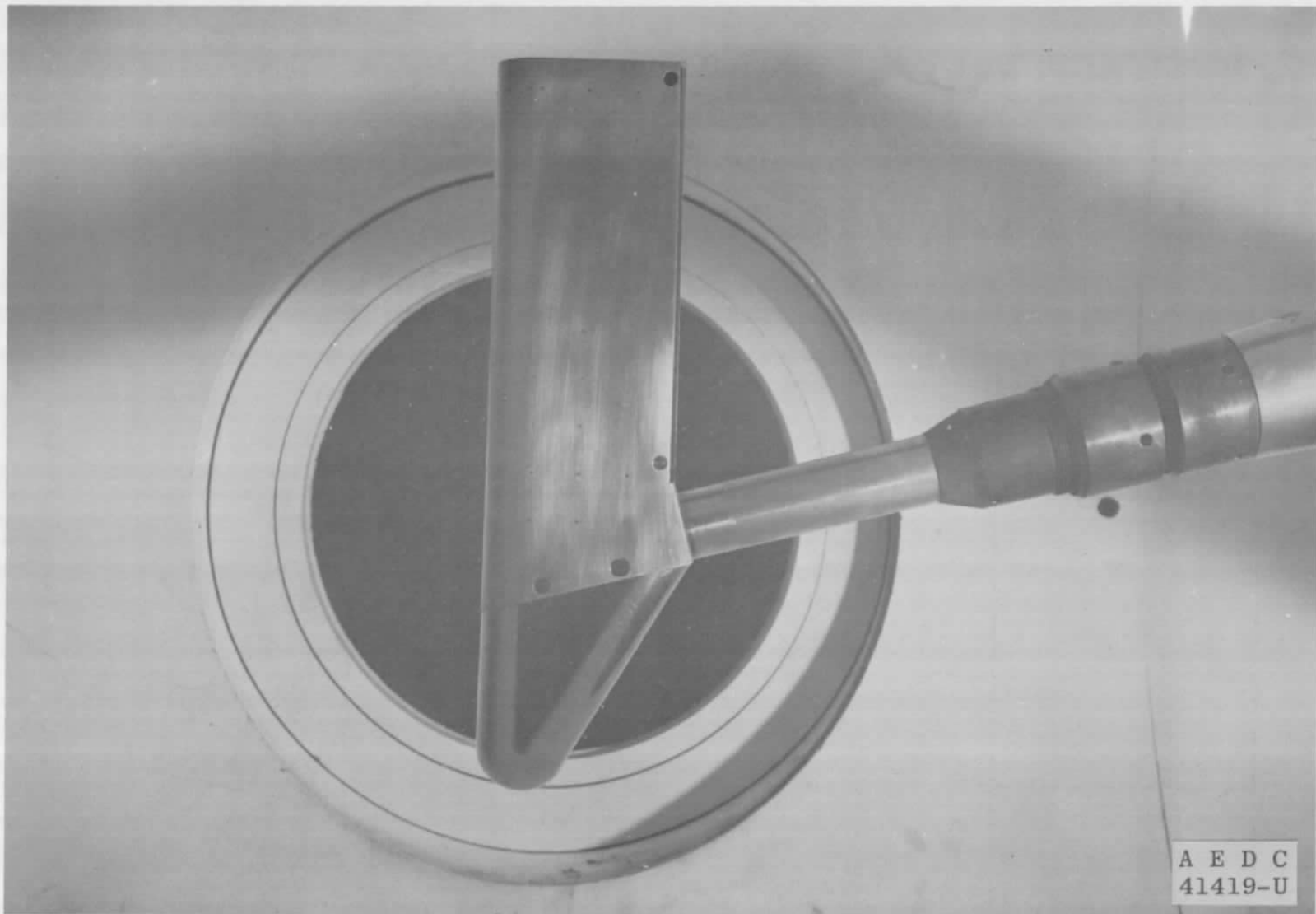

a. Blunt Nose Model in Tunnel B  
Fig. 3 Model Installation Photographs

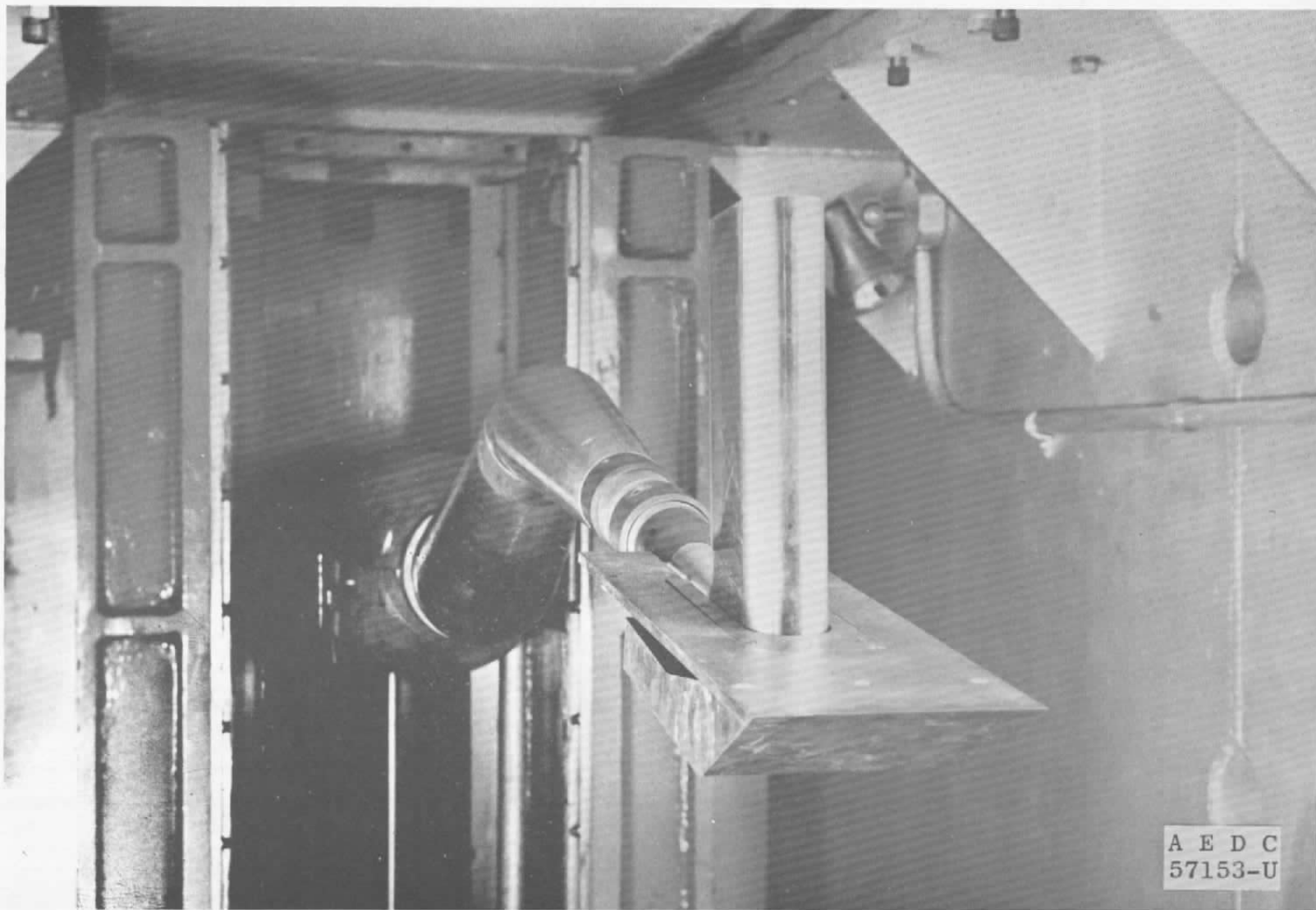

b. Shock Generator Model in Tunnel C, Retracted

Fig. 3 Concluded

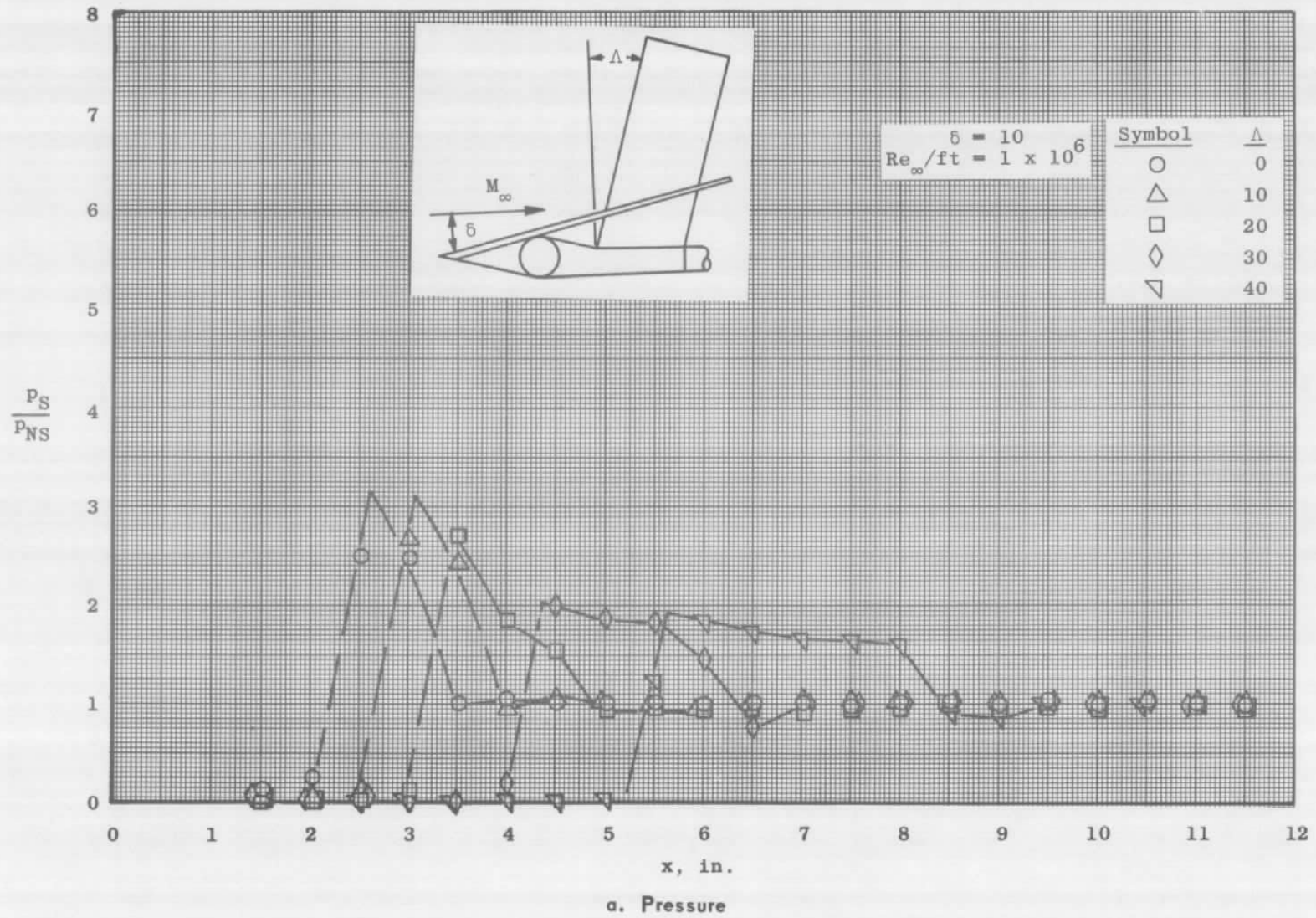
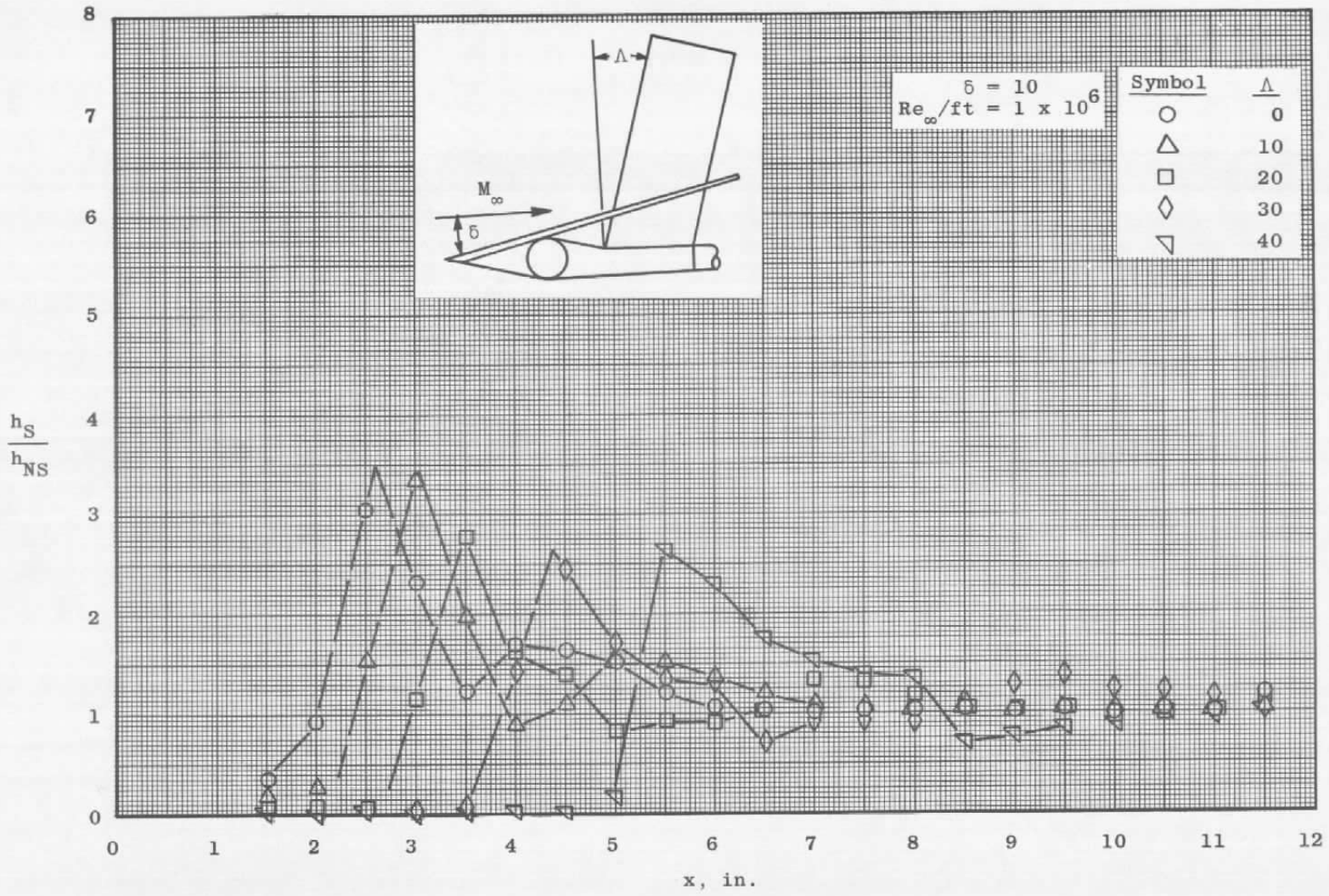

Fig. 4 Leading Edge Stagnation Line Shock Impingement Effects at Mach 6



b. Heat Transfer  
 Fig. 4 Concluded

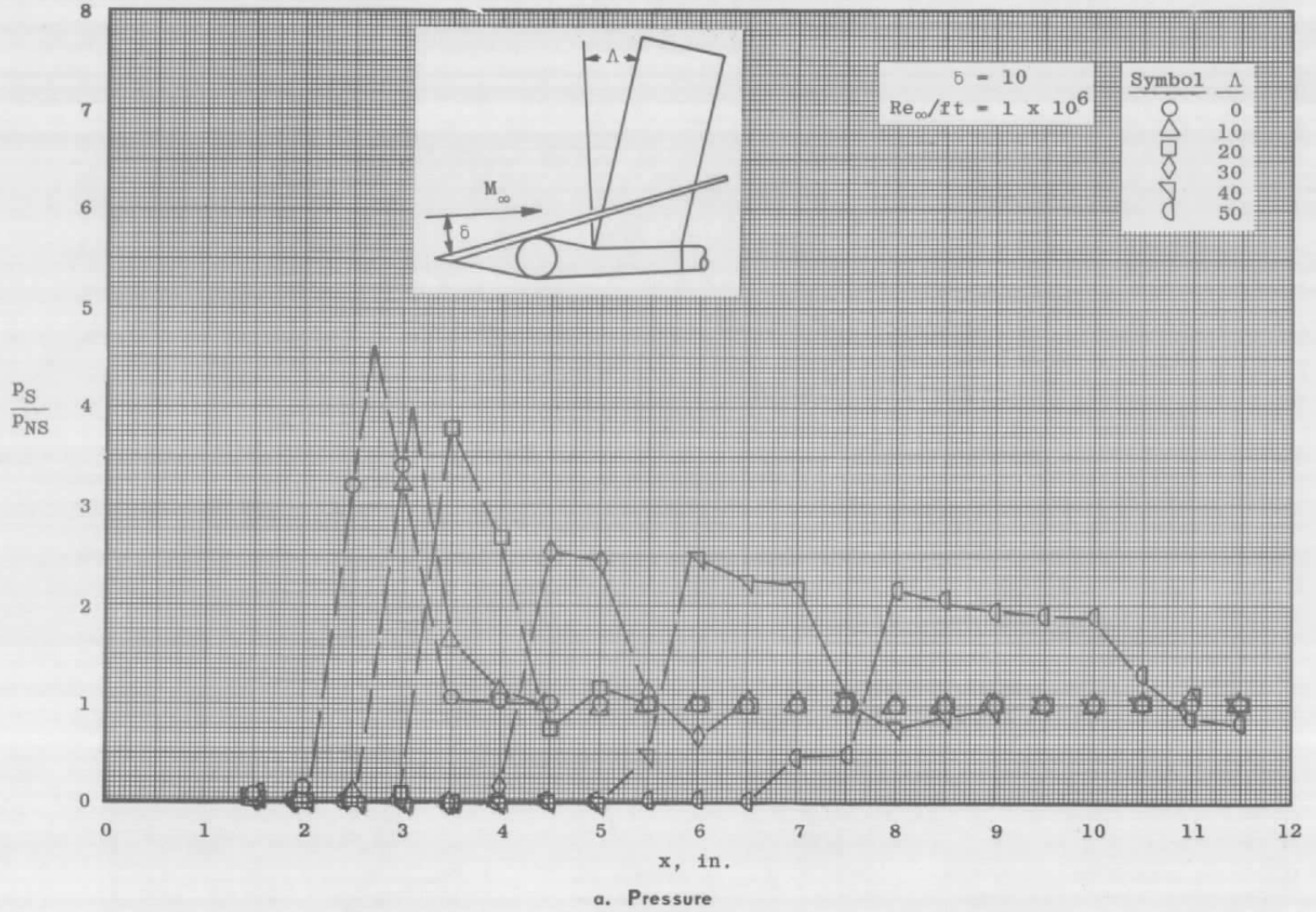
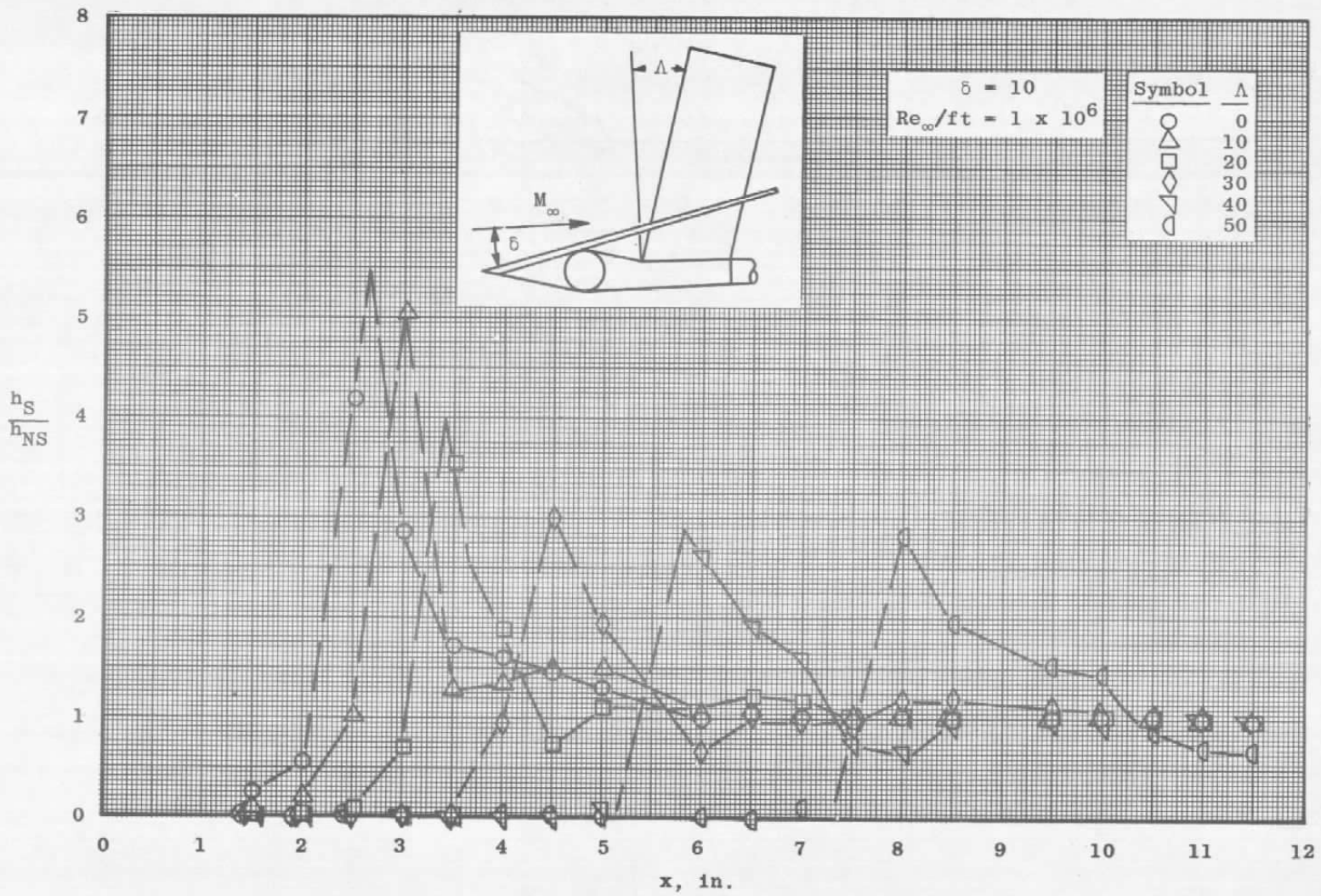

Fig. 5 Leading Edge Stagnation Line Shock Impingement Effects at Mach 10





b. Heat Transfer

Fig. 5 Concluded

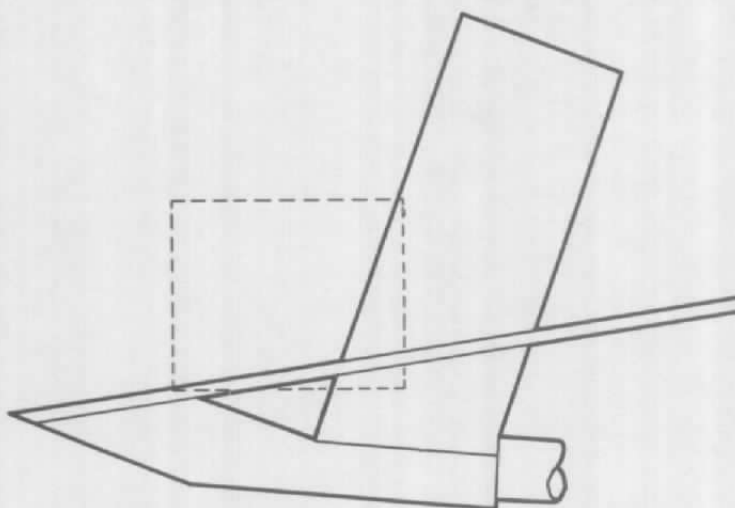
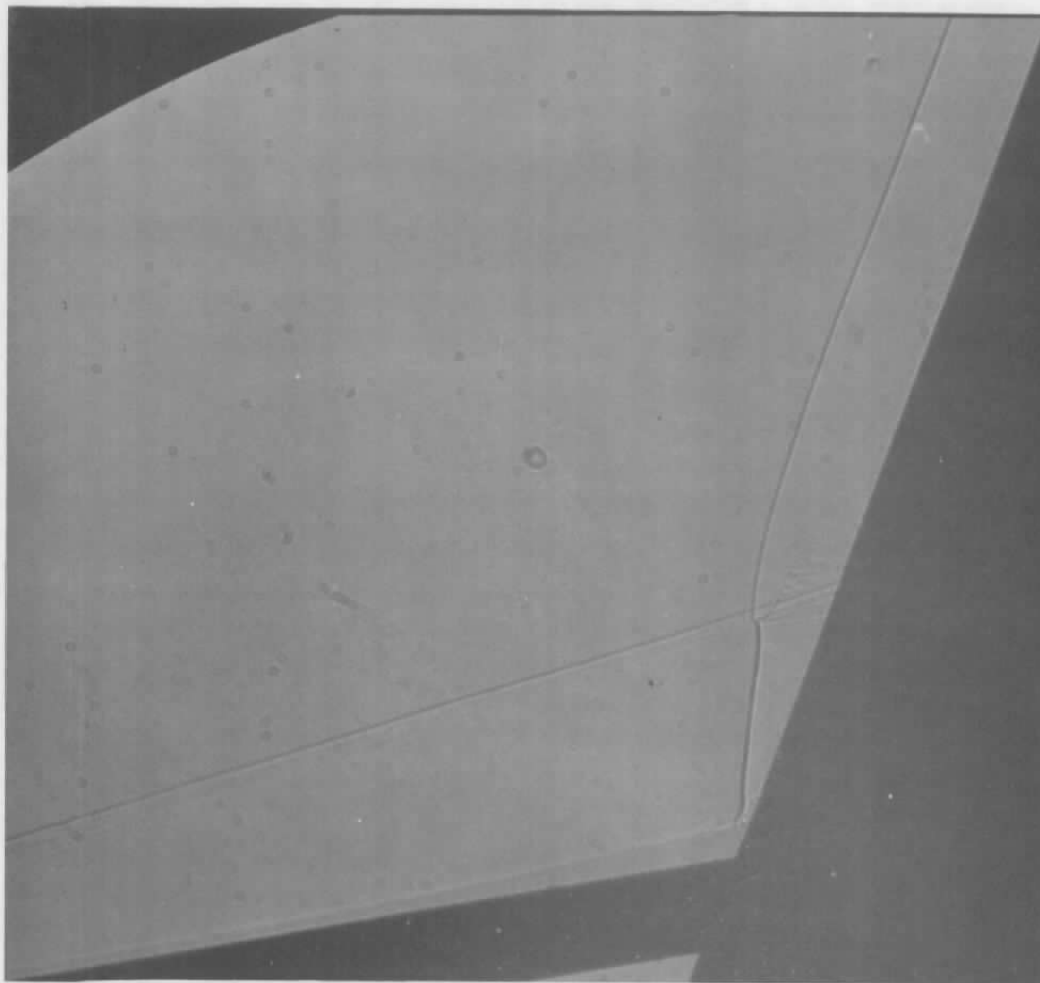

a. Separated Flow ( $\Lambda = 20$  deg)

Fig. 6 Shadowgraph of Shock Impingement Region,  $M_\infty = 6$ ,  $Re_\infty/ft = 1.0 \times 10^6$



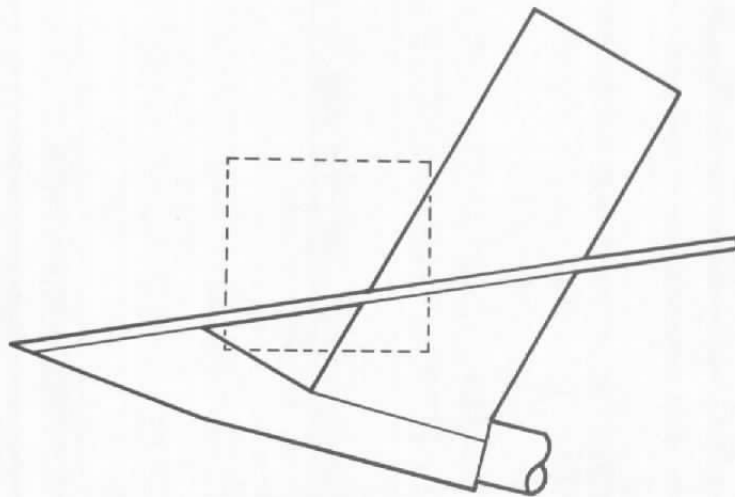
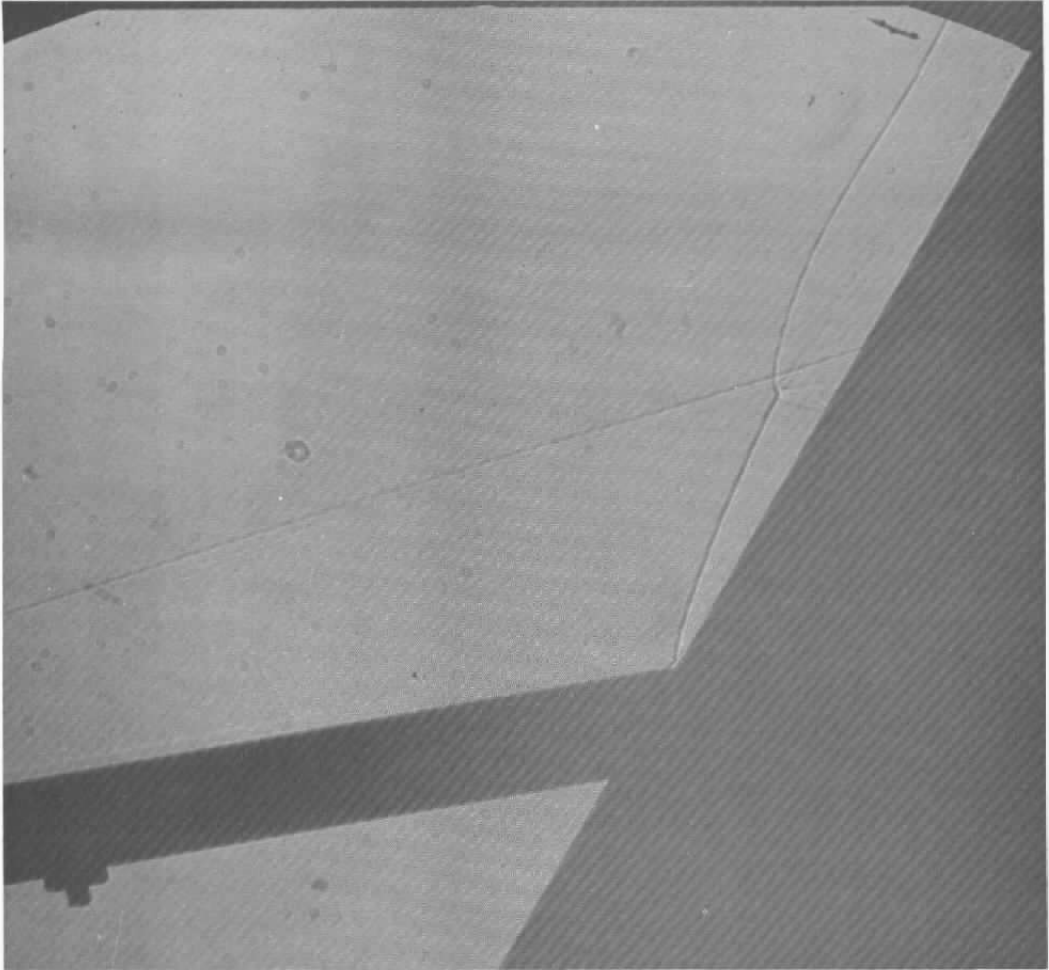

b. Attached Flow ( $\Lambda = 30$  deg)

Fig. 6 Concluded

## DOCUMENT CONTROL DATA - R&amp;D

(Security classification of title body of abstract and indexing annotation must be entered when the overall report is classified)

1 ORIGINATING ACTIVITY (Corporate author) Arnold Engineering Development Center ARO, Inc., Operating Contractor Arnold Air Force Station, Tennessee		2a REPORT SECURITY CLASSIFICATION UNCLASSIFIED	
		2b GROUP N/A	
3 REPORT TITLE AN INVESTIGATION OF THE EFFECTS OF SHOCK IMPINGEMENT ON A BLUNT LEADING EDGE			
4 DESCRIPTIVE NOTES (Type of report and inclusive dates) N/A			
5 AUTHOR(S) (Last name, first name, initial) Ray, A. D. and Palko, R. L., ARO, Inc.			
6. REPORT DATE July 1965	7a TOTAL NO. OF PAGES 23	7b. NO. OF REFS 3	
8a CONTRACT OR GRANT NO. AF 40 (600)-1000	9a. ORIGINATOR'S REPORT NUMBER(S) AEDC-TR-65-153		
b. PROJECT NO. 1336	9b. OTHER REPORT NO(S) (Any other numbers that may be assigned this report) N/A		
c-Program Element 62405334			
d.Task 136607			
10 AVAILABILITY/LIMITATION NOTICES Qualified requesters may obtain copies of this report from DDC.			
11. SUPPLEMENTARY NOTES N/A	12. SPONSORING MILITARY ACTIVITY Air Force Flight Dynamics Laboratory Air Force Systems Command Wright-Patterson AF Base, Ohio		
13 ABSTRACT  Tests were conducted at hypersonic Mach numbers on a blunt leading edge model both with and without an impinging shock. The effects of Reynolds number, Mach number, leading edge sweep angle, and impinging shock strength on the temperature and pressure distribution for the leading edge were determined. The tests were conducted at nominal Mach numbers of 6, 8, and 10 at unit Reynolds numbers of $0.58 \times 10^6$ to $3.55 \times 10^6$ per foot with a sweep angle range of 0 to 75 deg. Selected results which show the effect of shock generator angle and sweep angle at Mach 6 and 10 are presented.			

14  KEY WORDS  shocks  hypersonic flow  heat transfer  impingement	LINK A		LINK B		LINK C	
	ROLE	WT	ROLE	WT	ROLE	WT

**INSTRUCTIONS**

**1. ORIGINATING ACTIVITY:** Enter the name and address of the contractor, subcontractor, grantee, Department of Defense activity or other organization (*corporate author*) issuing the report.

**2a. REPORT SECURITY CLASSIFICATION:** Enter the overall security classification of the report. Indicate whether "Restricted Data" is included. Marking is to be in accordance with appropriate security regulations.

**2b. GROUP:** Automatic downgrading is specified in DoD Directive 5200.10 and Armed Forces Industrial Manual. Enter the group number. Also, when applicable, show that optional markings have been used for Group 3 and Group 4 as authorized.

**3. REPORT TITLE:** Enter the complete report title in all capital letters. Titles in all cases should be unclassified. If a meaningful title cannot be selected without classification, show title classification in all capitals in parenthesis immediately following the title.

**4. DESCRIPTIVE NOTES:** If appropriate, enter the type of report, e.g., interim, progress, summary, annual, or final. Give the inclusive dates when a specific reporting period is covered.

**5. AUTHOR(S):** Enter the name(s) of author(s) as shown on or in the report. Enter last name, first name, middle initial. If military, show rank and branch of service. The name of the principal author is an absolute minimum requirement.

**6. REPORT DATE:** Enter the date of the report as day, month, year, or month, year. If more than one date appears on the report, use date of publication.

**7a. TOTAL NUMBER OF PAGES:** The total page count should follow normal pagination procedures, i.e., enter the number of pages containing information.

**7b. NUMBER OF REFERENCES:** Enter the total number of references cited in the report.

**8a. CONTRACT OR GRANT NUMBER:** If appropriate, enter the applicable number of the contract or grant under which the report was written.

**8b, 8c, & 8d. PROJECT NUMBER:** Enter the appropriate military department identification, such as project number, subproject number, system numbers, task number, etc.

**9a. ORIGINATOR'S REPORT NUMBER(S):** Enter the official report number by which the document will be identified and controlled by the originating activity. This number must be unique to this report.

**9b. OTHER REPORT NUMBER(S):** If the report has been assigned any other report numbers (*either by the originator or by the sponsor*), also enter this number(s).

**10. AVAILABILITY/LIMITATION NOTICES:** Enter any limitations on further dissemination of the report, other than those

imposed by security classification, using standard statements such as:

- (1) "Qualified requesters may obtain copies of this report from DDC."
- (2) "Foreign announcement and dissemination of this report by DDC is not authorized."
- (3) "U. S. Government agencies may obtain copies of this report directly from DDC. Other qualified DDC users shall request through \_\_\_\_\_."
- (4) "U. S. military agencies may obtain copies of this report directly from DDC. Other qualified users shall request through \_\_\_\_\_."
- (5) "All distribution of this report is controlled. Qualified DDC users shall request through \_\_\_\_\_."

If the report has been furnished to the Office of Technical Services, Department of Commerce, for sale to the public, indicate this fact and enter the price, if known.

**11. SUPPLEMENTARY NOTES:** Use for additional explanatory notes.

**12. SPONSORING MILITARY ACTIVITY:** Enter the name of the departmental project office or laboratory sponsoring (*paying for*) the research and development. Include address.

**13. ABSTRACT:** Enter an abstract giving a brief and factual summary of the document indicative of the report, even though it may also appear elsewhere in the body of the technical report. If additional space is required, a continuation sheet shall be attached.

It is highly desirable that the abstract of classified reports be unclassified. Each paragraph of the abstract shall end with an indication of the military security classification of the information in the paragraph, represented as (TS), (S), (C), or (U).

There is no limitation on the length of the abstract. However, the suggested length is from 150 to 225 words.

**14. KEY WORDS:** Key words are technically meaningful terms or short phrases that characterize a report and may be used as index entries for cataloging the report. Key words must be selected so that no security classification is required. Identifiers, such as equipment model designation, trade name, military project code name, geographic location, may be used as key words but will be followed by an indication of technical context. The assignment of links, rules, and weights is optional.