

UNCLASSIFIED

AD NUMBER
AD460890
NEW LIMITATION CHANGE
TO Approved for public release, distribution unlimited
FROM Distribution authorized to U.S. Gov't. agencies and their contractors; Administrative/Operational Use; Feb 1965. Other requests shall be referred to Air Force Flight Dynamics lab., Wright-Patterson AFB, OH 45433.
AUTHORITY
USAF ltr, 6 Aug 1974

THIS PAGE IS UNCLASSIFIED

UNCLASSIFIED

460890

ENSE DOCUMENTATION CENTER

FOR

SCIENTIFIC AND TECHNICAL INFORMATION

AMERSON STATION ALEXANDRIA, VIRGINIA



UNCLASSIFIED

NOTICE: When government or other drawings, specifications or other data are used for any purpose other than in connection with a definitely related government procurement operation, the U. S. Government thereby incurs no responsibility, nor any obligation whatsoever; and the fact that the Government may have formulated, furnished, or in any way supplied the said drawings, specifications, or other data is not to be regarded by implication or otherwise as in any manner licensing the holder or any other person or corporation, or conveying any rights or permission to manufacture, use or sell any patented invention that may in any way be related thereto.

FDL-TDR-64-155

CATALOGED BY: DDC

AS AD No 460890

DRAG AND STABILITY OF CROSS TYPE PARACHUTES

R. J. NICCUM
E. L. HAAK
ROBERT GUTENKAUF

UNIVERSITY OF MINNESOTA

TECHNICAL DOCUMENTARY REPORT No. FDL-TDR-64-155

FEBRUARY 1965

DDC
RECEIVED
APR 19 1965
DDC-IRA E

AIR FORCE FLIGHT DYNAMICS LABORATORY
RESEARCH AND TECHNOLOGY DIVISION
AIR FORCE SYSTEMS COMMAND
WRIGHT-PATTERSON AIR FORCE BASE, OHIO

460890

NOTICES

When Government drawings, specifications, or other data are used for any purpose other than in connection with a definitely related Government procurement operation, the United States Government thereby incurs no responsibility nor any obligation whatsoever; and the fact that the Government may have formulated, furnished, or in any way supplied the said drawings, specifications, or other data, is not to be regarded by implication or otherwise as in any manner licensing the holder or any other person or corporation, or conveying any rights or permission to manufacture, use, or sell any patented invention that may in any way be related thereto.

Qualified users may obtain copies of this report from Defense Documentation Center.

Foreign announcement and dissemination of this report is not authorized.

DDC release to CFSTI is not authorized. The distribution of this report is limited because the report contains technology identifiable with items on the strategic embargo lists excluded from export or re-export under U. S. Export Control Act of 1949 (63 Stat. 7) as amended (50 U. S. C. App. 2020.2031) as implemented by AFR 400-10.

Copies of this report should not be returned to the Research and Technology Division unless return is required by security considerations, contractual obligations, or notice on a specific document.

DRAG AND STABILITY OF CROSS TYPE PARACHUTES

*R. J. NICCUM
E. L. HAAK
ROBERT GUTENKAUF*

FOREWORD

This report was prepared by the Department of Aeronautics and Engineering Mechanics of the University of Minnesota in compliance with AF Contract No. AF33(657)-11184, Project No. 6065 and Task No. 606503. The work being accomplished under this contract is sponsored jointly by U. S. Army Natick Laboratory, Department of the Army; Bureau of Aeronautics and Bureau of Ordnance, Department of the Navy; and Air Force Systems Command, Department of the Air Force, and is directed by a Tri-Service Steering Committee concerned with Aerodynamic Retardation. Contract administration has been conducted by the Research and Technology Division (AFSC), and Messrs. Rudi J. Berndt and James H. DeWeese of the Recovery and Crew Station Branch, AF Flight Dynamics Laboratory, have been project engineers.

This study was accomplished under the direction of Prof. H. G. Heinrich. Several graduate and undergraduate students in aerospace engineering participated in the performance of the experiments and data evaluation. The authors wish to express their appreciation to them.

This technical documentary report has been reviewed and is approved.

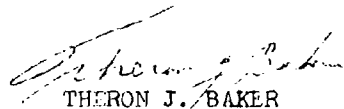

THERON J. BAKER
Vehicle Equipment Division
AF Flight Dynamics Laboratory

ABSTRACT

Wind tunnel studies have been performed on several configurations of the Cross parachute. Both the canopy geometry and the cloth porosity have been varied to provide data over the entire range for which the canopy may be used. In addition, the performance of these canopies in the wake of a forebody has been evaluated.

This report contains the results of three-component studies on these models as well as a discussion of the canopy performance in light of the tests performed.

TABLE OF CONTENTS

	PAGE
1. Introduction	1
2. Experimental Procedure	2
A. Coordinate System and Coefficients	2
B. Models	2
C. Test Arrangement and Procedure	7
3. Results and Conclusions	12
A. Aerodynamic Characteristics of Cross Parachutes Singly Suspended	12
B. Aerodynamic Characteristics of the Cross Parachute in the Wake of the A-21 Cargo Container	17
C. Comparison of Full Scale and Model Tests	22
4. Summary	25
Appendix	27
References	30

ILLUSTRATIONS

FIGURE		PAGE
1.	Parachute Coordinate System and Forces	3
2.	Cross Type Parachute Model Configurations	5
3.	Inflated Parachute Models in Wind Tunnel	8
4.	Model Suspension System	9
5.	Model Suspension and Strain Gage Balance Arrangement	9
6.	Mounting System of A-21 Forebodies with Simulated Riser Lengths	11
7.	Aerodynamic Coefficients vs Angle of Attack for Cross Type Parachutes of Various Nominal Porosities ($W/L = .333$, Geometric Porosity 29.3%)	13
8.	Aerodynamic Coefficients vs Angle of Attack for Cross Type Parachutes of Various Nominal Porosities ($W/L = .264$, Geometric Porosity 41.7%)	14
9.	Aerodynamic Coefficients vs Angle of Attack for Cross Type Parachutes of Various Nominal Porosities ($W/L = .194$, Geometric Porosity 55.3%)	15
10.	Slope of Moment Coefficient Curve at Zero Angle of Attack as a Function of Effective Porosity at Various W/L Values	16
11.	Slope of Moment Coefficient Curve at Zero Angle of Attack as a Function of Geometric Porosity for Cross Parachutes at Various Effective Porosities	16

ILLUSTRATIONS (cont.)

FIGURE		PAGE
12.	Aerodynamic Coefficients vs Angle of Attack for Cross Parachutes with A-21 Forebody ($b/L = .278$ and Riser Length = $.80L$)	18
13.	Aerodynamic Coefficients vs Angle of Attack for Cross Parachutes with A-21 Forebody ($b/L = .278$ and Riser Length = $.14L$)	19
14.	Aerodynamic Coefficients vs Angle of Attack for Cross Parachutes with A-21 Forebody ($b/L = .112$ and Riser Length = $.06L$)	20
15.	Drag Coefficient as a Function of Equilibrium Velocity for Several Full Scale and Wind Tunnel Tests	23

TABLES

TABLE		PAGE
1.	Design Characteristics of Cross Parachute Models	6
2.	Stability and Drag Characteristics of Cross Parachutes in Free Stream	17
3.	Stability and Drag Characteristics of Cross Parachutes with A-21 Forebody	21
4.	Aerodynamic Coefficients of Cross Parachutes with $W/L = .333$	28
5.	Aerodynamic Coefficients of Cross Parachutes with $W/L = .264$	28
6.	Aerodynamic Coefficients of Cross Parachutes with $W/L = .194$	28
7.	Aerodynamic Coefficients for Cross Parachutes with A-21 Forebody; $b/L = .278$ and $.80L$ Riser	29
8.	Aerodynamic Coefficients for Cross Parachutes with A-21 Forebody; $b/L = .278$ and $.14L$ Riser	29
9.	Aerodynamic Coefficients for Cross Parachutes with A-21 Forebody; $b/L = .112$ and $.06L$ Riser	29

SYMBOLS

A	frontal area of forebody
b	maximum frontal dimension of forebody
C	effective porosity
C _M	moment coefficient
C _N	normal force coefficient
C _T	tangent force coefficient
D ₀	nominal diameter based on S ₀
d	total inflated model length
h	inflated canopy depth
k	moment arm
L	canopy panel length
l	suspension line length
M	moment
N	normal force
q	dynamic pressure = $\frac{1}{2}\rho V^2$
S ₀	essential canopy area (no overlapping)
T	tangent force
U	average velocity through parachute cloth
V	velocity
W	canopy panel width
α	angle of attack
ρ	air density
λ	geometric porosity

1. INTRODUCTION

The Cross parachute has demonstrated a high degree of stability as well as satisfactory drag characteristics in full scale drop tests. Its use as a cargo parachute is further enhanced by the apparent ease and economy of fabrication.

In an effort to evaluate the performance of this type of canopy under laboratory conditions, and further, to determine a possible optimum configuration, the University of Minnesota has performed a series of wind tunnel studies on several Cross type canopy designs both in free stream and in the wake of simulated cargo containers.

Manuscript released by authors May 1964 for publication
as an FDL Technical Documentary Report.

2. EXPERIMENTAL PROCEDURE

A. Coordinate System and Coefficients

The parachute coordinate system (Fig 1) uses the physical coordinates of the parachute as the major reference axes. The pertinent forces and moments are the following:

- a) The tangent force, T, acting along the centerline of the parachute;
- b) The normal force, N, acting perpendicular to the parachute centerline;
- c) The moment, M, is defined as the aerodynamic moment about a moment center located one parachute nominal diameter, D_o , upstream from the skirt of the canopy. This is considered a stabilizing moment when the slope of the curve,

$$\frac{dC_M}{d\alpha} < 0. \quad (\text{Ref 1}).$$

The force and moment coefficients were calculated from test data and employ the conventional aerodynamic relationships, where $C_{T_o} = \frac{T}{qS_o}$, $C_{N_o} = \frac{N}{qS_o}$ and $C_{M_o} = \frac{M}{qS_o D_o}$. In Ref 1 it is shown that the relationship $M = Nk$ may be used.

The nominal diameter, used in determining the moment coefficients for the Cross parachute models, is defined as:

$$D_o = \sqrt{\frac{4 S_o}{\pi}},$$

where S_o is the essential cloth area (ie. no overlapping) of the canopy panels.

B. Models

Design data for the original 18 foot diameter Cross type configuration was supplied by the Aeronautical Systems Division, Wright-Patterson Air Force Base, Ohio. The model of this canopy was constructed of two panels each having a width to length ratio (W/L) of 0.264, sewn together perpendicular

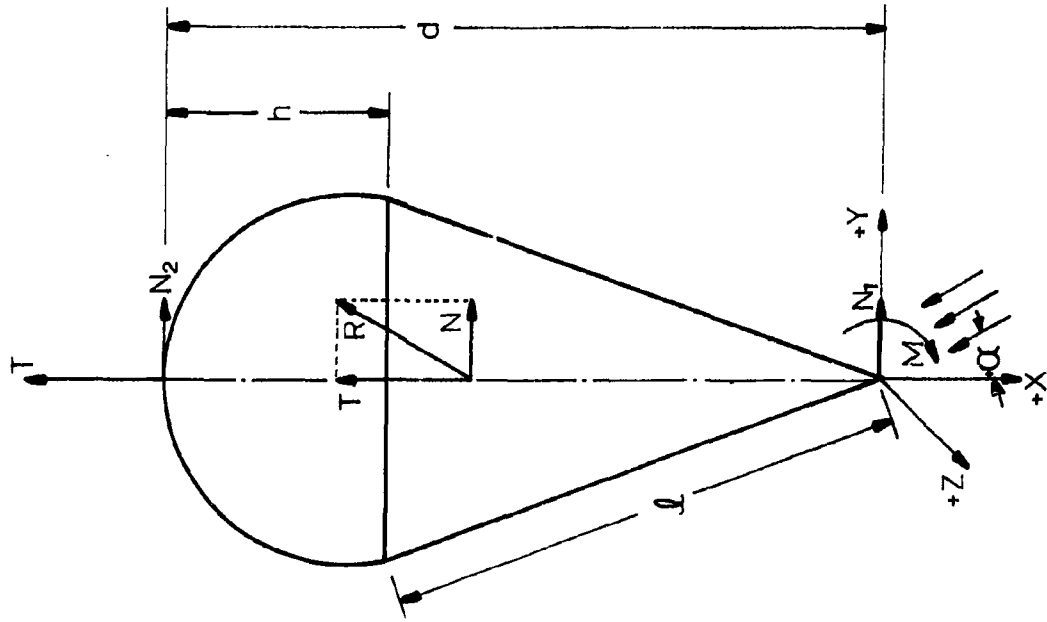

A). GENERAL SYSTEM

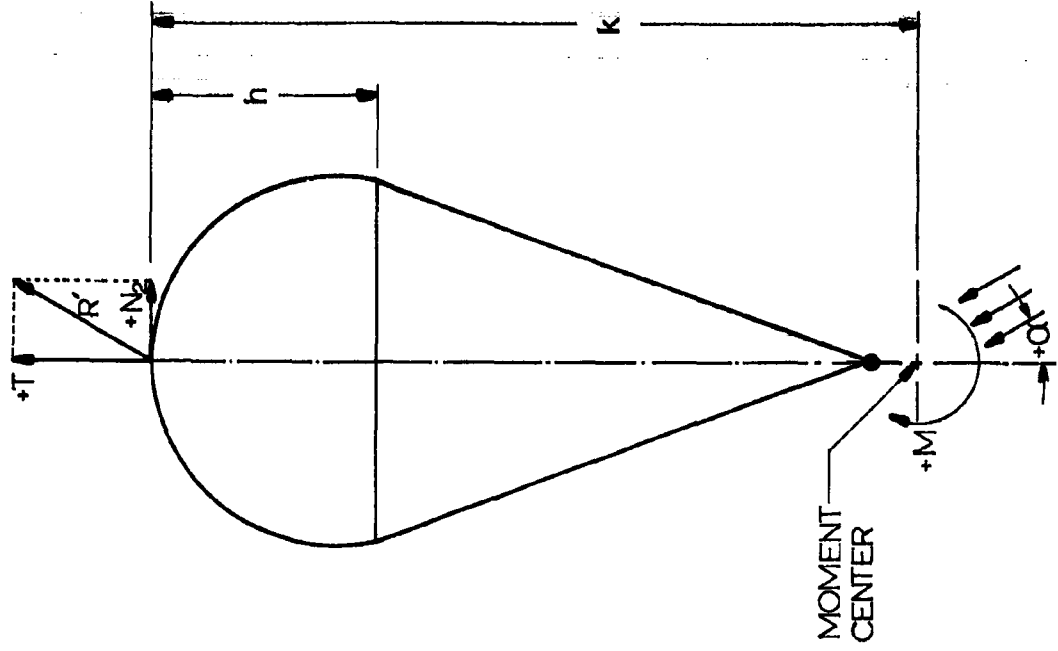

B). WIND TUNNEL SYSTEM (NEGLECTING N_1)

FIG 1. PARACHUTE COORDINATE SYSTEM AND FORCES

to each other (Fig 2). Four canopy models were constructed with this W/L configuration, having porosities shown in Table 1. This tabulation also shows the pertinent data for two other W/L configurations with various cloth porosities.

The nominal porosity range of the parachute materials used in this investigation and presented in Table 1 represents a volumetric flow in units of ft^3/ft^2 -min at $\frac{1}{2}$ inch H_2O differential pressure.

A second cloth parameter, to which later reference will be made, is the effective porosity of the material. This is defined as the ratio of the average velocity, U, through the porous cloth surface to a fictitious free stream velocity, V, defined by the differential pressure across the cloth (Ref 2). By the method outlined in Ref 2 the effective porosities of the cloth materials used were measured at the same density ratio and differential pressure existing in the wind tunnel tests.

The geometric porosity shown in Table 1 is obtained by circumscribing a circle with a diameter equal to the panel length, L, around the canopy. The ratio of the open area to the total area of this disk is defined as the geometric porosity.

Each parachute model has a panel length, L, of 18 inches and 20 suspension lines each 18 inches in length of 100 lb nylon cord. A total of ten models were tested in free stream and three of these were selected for further examination in the wake of a forebody.

Two A-21 cargo container models were used for the wake experiments. The dimensions of the container models, in view of the existing parachute models, were determined as follows. The A-21 cargo container is designed for loads ranging from approximately 100 to 500 lbs (Ref 3). Using average free stream tangent force coefficient values and assuming an equilibrium velocity of 25 ft/sec, the necessary

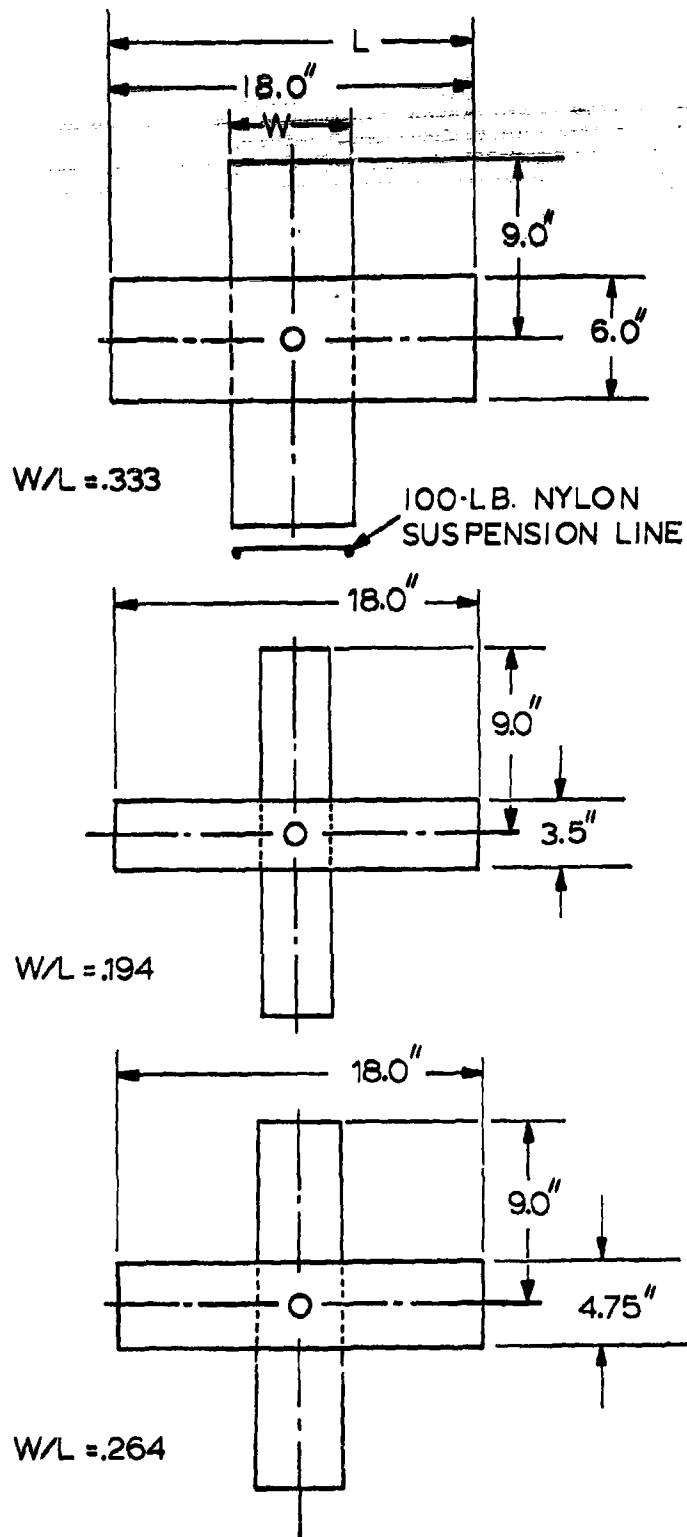

FIG 2. CROSS TYPE PARACHUTE MODEL CONFIGURATIONS

TABLE 1 DESIGN CHARACTERISTICS OF CROSS PARACHUTE MODELS

WIDTH W (in.)	$\frac{W}{L}$ (L = 18")	ESSENTIAL CLOTH AREA S_0 (ft ²)	NOMINAL DIAMETER D_0 (ft)	MOMENT ARM K (ft)	GEOMETRIC POROSITY λ	NOMINAL POROSITY	CLOTH SPECIFICATION (MIL-C No.)
6.00	.333	1.25	1.26	1.96 2.00 2.02	29.3%	9 - 11 60 - 90 120	107470 - D 8021 A -- I 7020B-- I
4.75	.264	1.03	1.16	1.94 1.96 1.98 1.98	41.7%	9 - 11 60 - 90 120 194	107470 - D 8021 A -- I 7020 B -- I COTTON PRINT
3.50	.194	.79	1.00	1.98 1.94 2.00	55.3%	9 - 11 60 - 90 120	107470 - D 8021 A -- I 7020 B -- I

canopy area, S_0 , was calculated.

Calculations were made for container weights of 100 lbs and 500 lbs and the resulting scale factors for the container were derived to 1:12 and 1:30 for the 100 lb and 500 lb loads, respectively. Consequently, a parachute model which is combined with a simulated 100 lb container has a larger forebody than the same parachute model will have when combined with a 500 lb model container.

Forebody sizes relative to canopy panel length are $b/L = .278$ and $b/L = .112$ for the 100 lb and 500 lb loads, respectively, where b is the maximum dimension of the container, 60 inches full size. As a parameter, forebody size may be related to parachute size by the ratio A/S_0 , where A is the frontal area of the forebody, 60" x 40" full scale. These area ratios of the various canopy-container combinations are presented in Table 3.

C. Test Arrangement and Procedure

Experiments were conducted in a horizontal return, atmospheric pressure wind tunnel with a test section of 38" x 54". Models were suspended on a turntable which was revolved to obtain different angles of attack. Force measurements were taken at 5° increments for large angles and $2\frac{1}{2}^\circ$ increments for angles of attack near zero. Normal and tangent force measurements were made by a strain gage balance and electronic recording system. Details of the method of force measurement and the force recording system are presented in Ref 1. Figure 3 shows three inflated models in the wind tunnel. Schematic drawings of the suspension system, and of the devices used to measure normal and tangent forces, are shown in Figs 4 and 5, respectively.

The test arrangements and procedure for the investigation of the Cross parachute in the wake of an A-21 forebody were basically the same as above. The only modification required

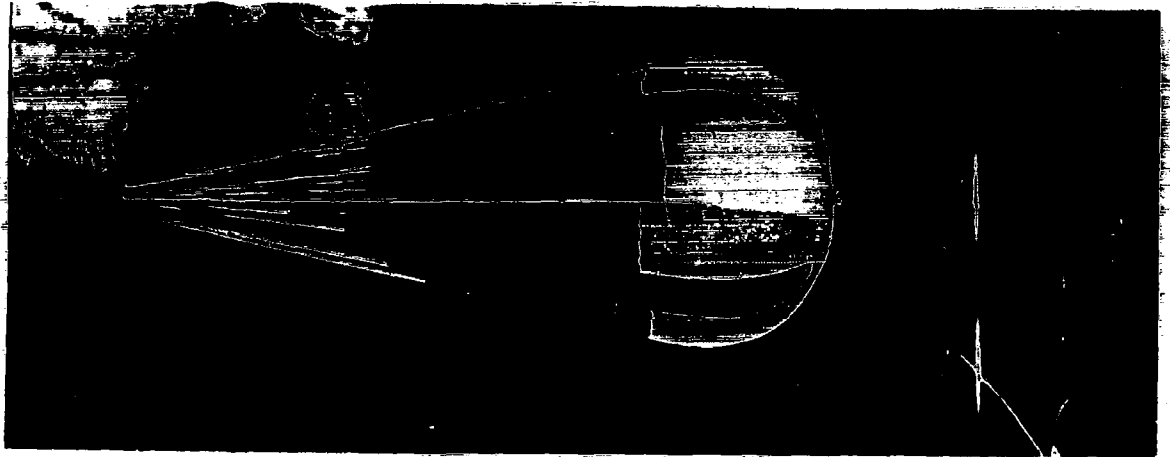

W/L = .194

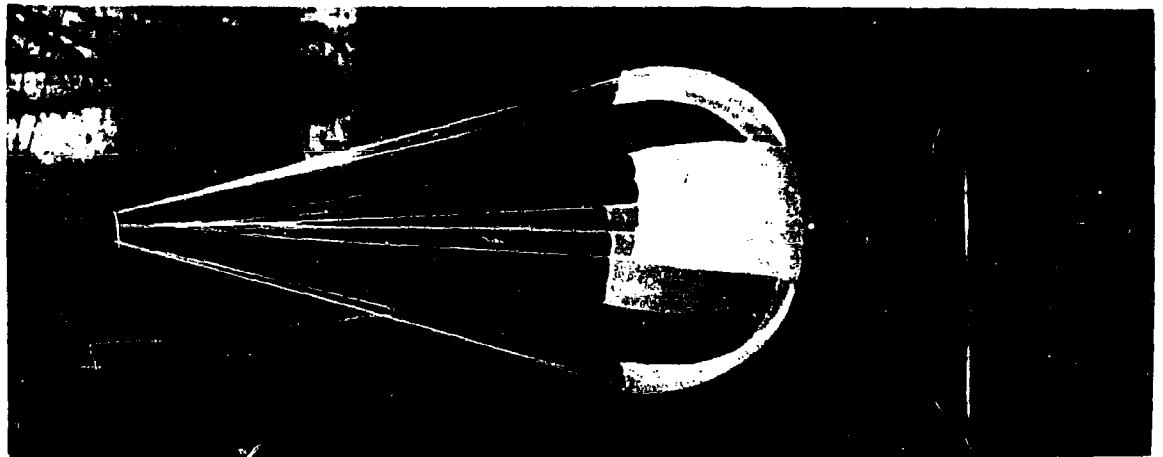

W/L = .264

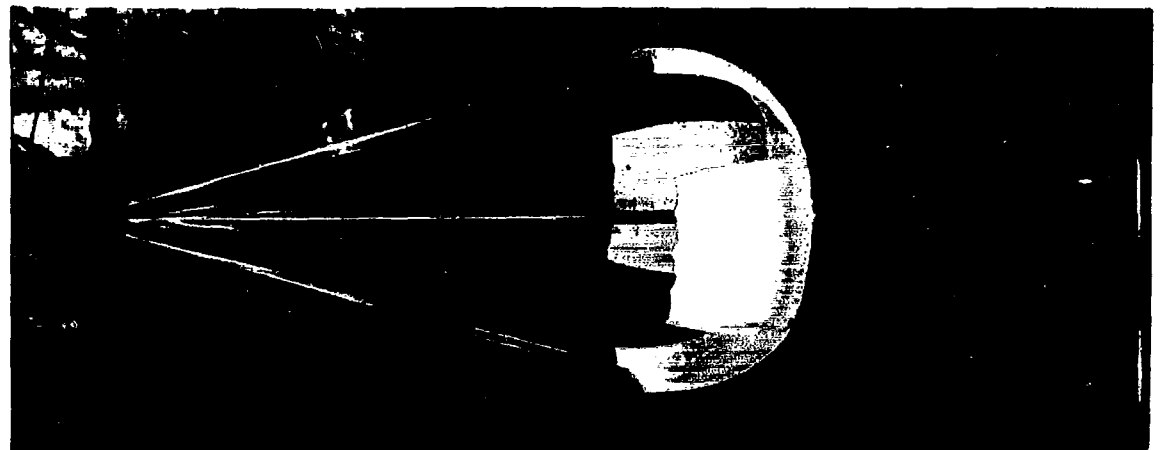

W/L = .333

FIG 3 INFLATED PARACHUTE MODELS IN WIND TUNNEL

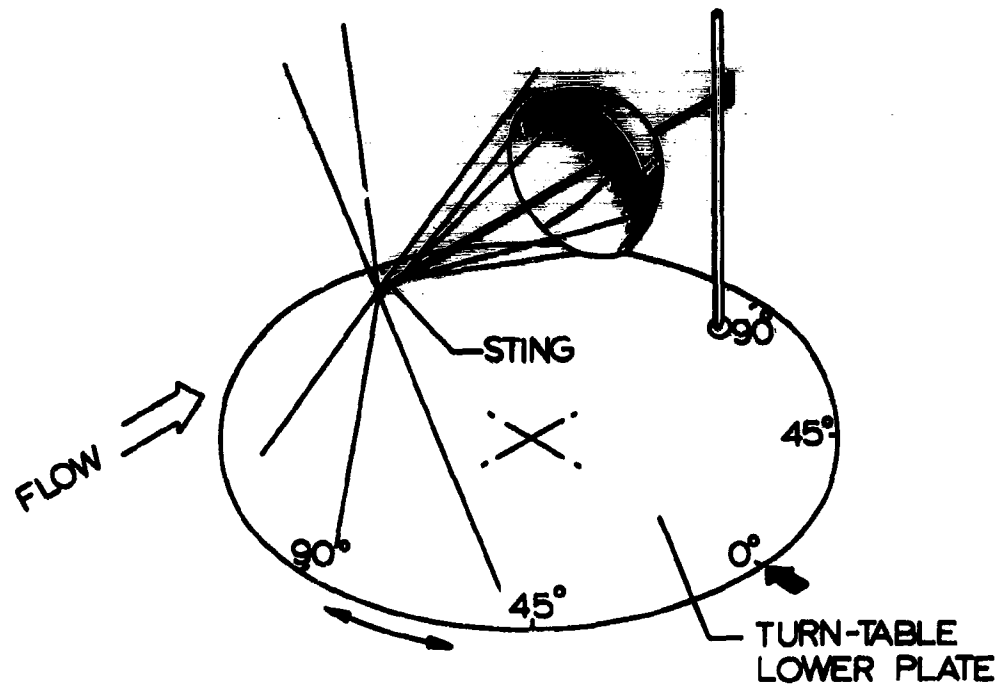

FIG 4. MODEL SUSPENSION SYSTEM

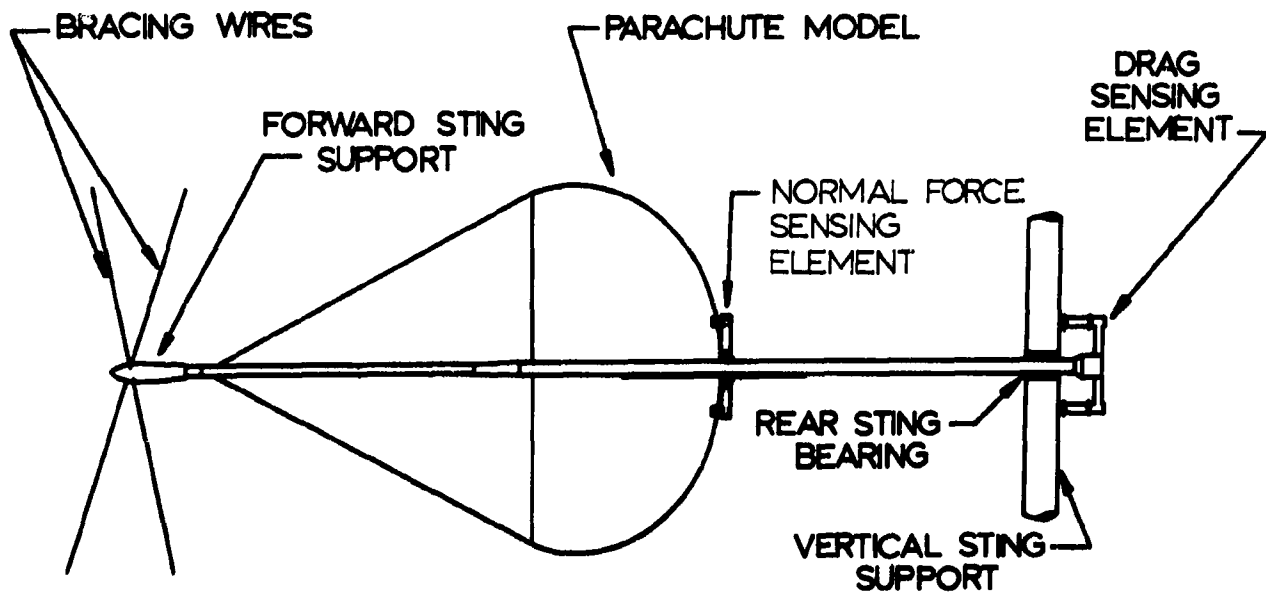
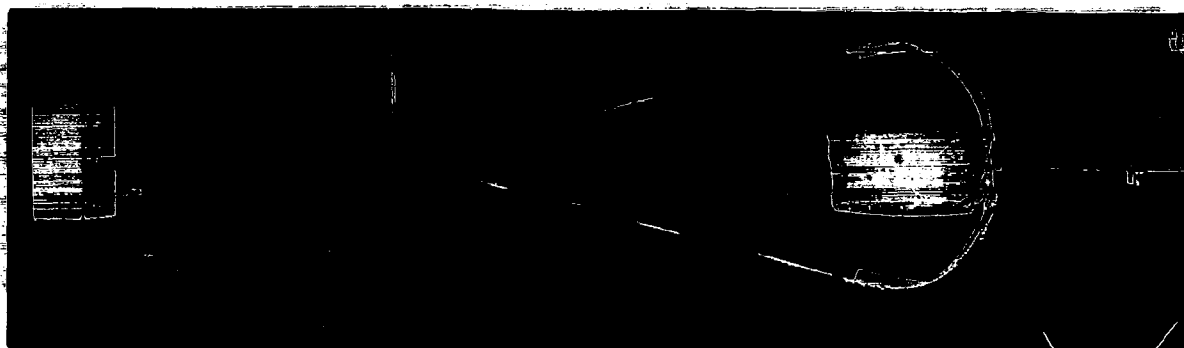

FIG 5. MODEL SUSPENSION AND STRAIN GAGE BALANCE ARRANGEMENT

is the mounting of the forebody by means of a sting extension which simulates the riser length.

Three riser length - forebody combinations were used in the tests (Fig 6). The 1/12 scale A-21 forebody, representing a 100 lb load, was tested with a riser length of .80L, simulating a riser approximately equal to the nominal diameters of the parachutes tested. This same forebody was also tested with a riser length of .14L, representing a standard 30 inch cargo parachute riser (Ref 4). The 1/30 scale A-21 forebody, representing the 500 lb load, was tested with a riser length of .06L, again representing a standard riser. Each test arrangement was designed so that only those forces acting on the parachute were measured, the forces on the forebody being absorbed by the forward sting support.

All experiments were conducted at a free stream velocity of 66 ft/sec, corresponding to a Reynolds number, based on nominal diameter, of approximately 4.5×10^5 . Tests were repeated several times on each model to assure reliable results.



$b/L = .278$ AND $.80L$ RISER

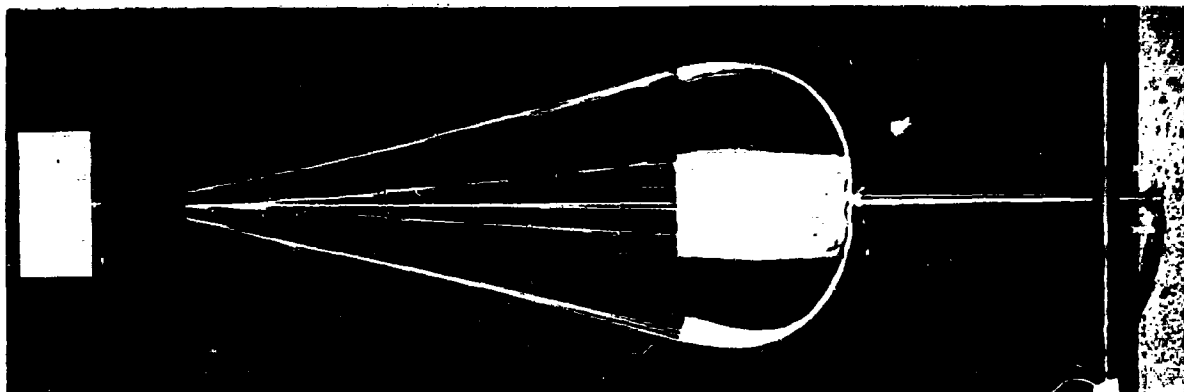

$b/L = .278$ AND $.14L$ RISER

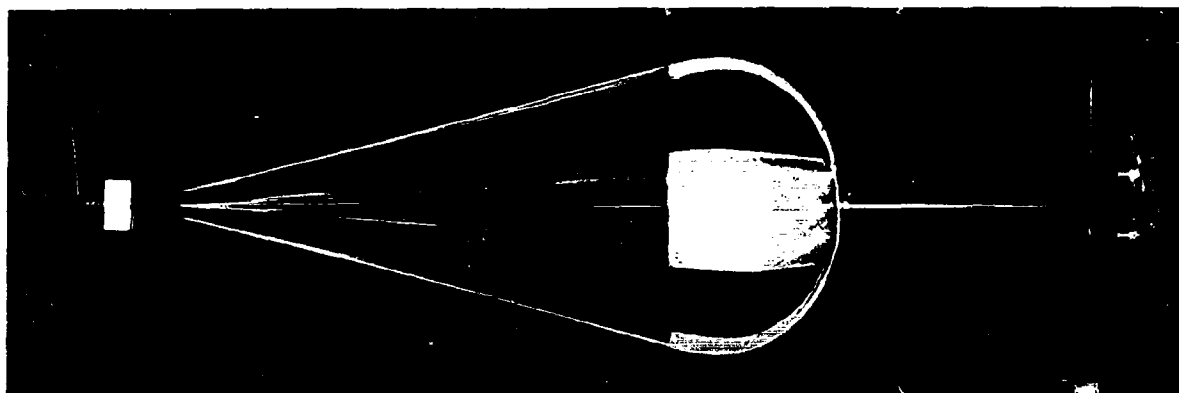

$b/L = .112$ AND $.06L$ RISER

FIG. 6 MOUNTING SYSTEM OF A-21 FOREBODIES
WITH SIMULATED RISER LENGTHS

3. RESULTS AND CONCLUSIONS

A. Aerodynamic Characteristics of Cross Parachutes Singly Suspended

The aerodynamic coefficients of the models tested are presented in Figs 7, 8 and 9 as a function of angle of attack. The tangent force coefficient decreases as expected with increasing nominal and geometric porosity. In particular, the Cross parachute with a geometric porosity of 29.3% is stable only when built out of high porosity cloth (Fig 7).

The stability derivative, $\left. \frac{\partial C_M}{\partial \alpha} \right|_{\alpha=0}$, decreases with increasing effective porosity for configurations with $W/L = 0.333$ but increases for configurations with $W/L = 0.194$ (Fig 10). The intermediate configuration, $W/L = 0.264$, appears to represent a transition region in the stability trend, since stability changes only slightly with effective porosity. This indicates that the canopy stability is a function of geometric porosity or inflated canopy shape, as well as of cloth porosity.

A graph of the stability derivative, $\left. \frac{\partial C_M}{\partial \alpha} \right|_{\alpha=0}$, as a function of geometric porosity (based on a disk of diameter L) (Fig 11) for constant cloth porosities shows that the curves for various effective porosities have a common point of intersection at approximately 44% geometric porosity. For the geometric porosity range lower than 44 per cent, the parachutes behave in the conventional manner, with the canopies having more porous cloth demonstrating higher stability characteristics. However, Cross parachutes with a geometric porosity larger than 44 per cent show a lesser degree of stability as the cloth porosity increases. Results of free stream studies are summarized in Table 2.

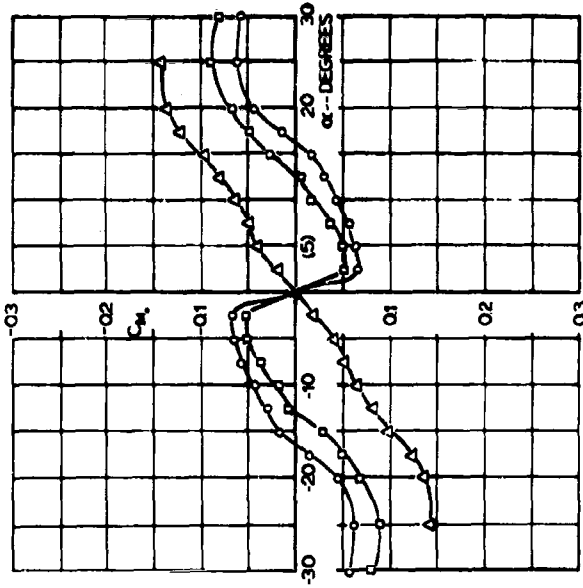

MOMENT COEFFICIENT

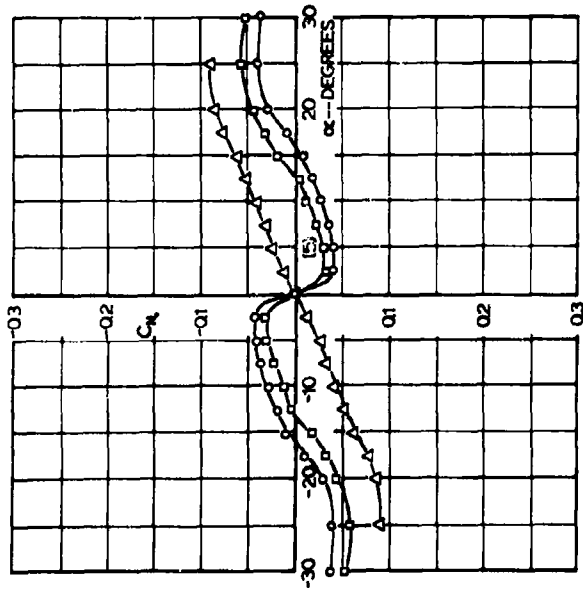

NORMAL FORCE COEFFICIENT

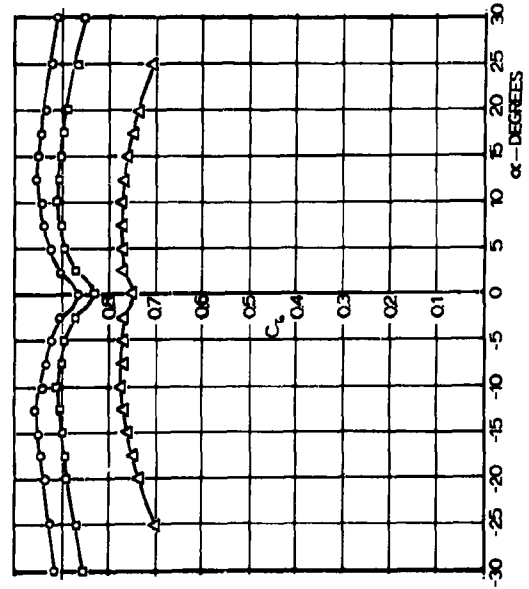

TANGENT FORCE COEFFICIENT

SYMBOL NOMINAL POROSITY

○ 9-11
 □ 60-90
 △ 120

FIG-7 AERODYNAMIC COEFFICIENTS VS
 ANGLE OF ATTACK FOR CROSS TYPE
 PARACHUTES OF VARIOUS NOMINAL POROSITIES
 ($WL=333$, GEOMETRIC POROSITY 29.3%)
 BASED ON S_p AND REYNOLDS NO. $\approx 4.5 \times 10^5$

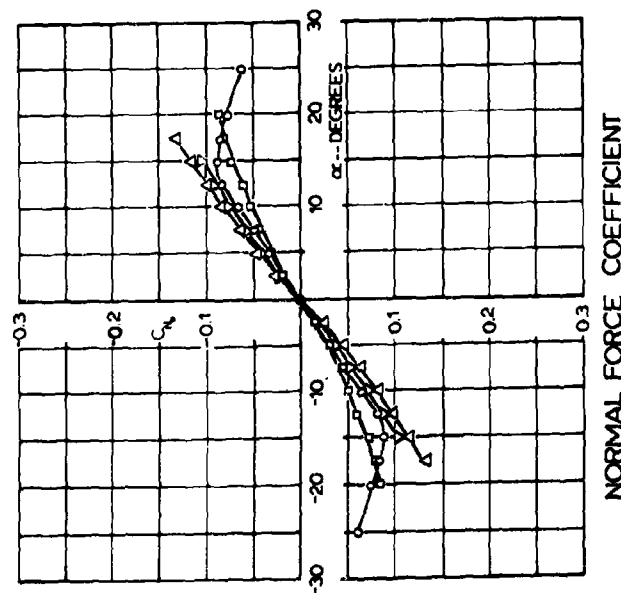
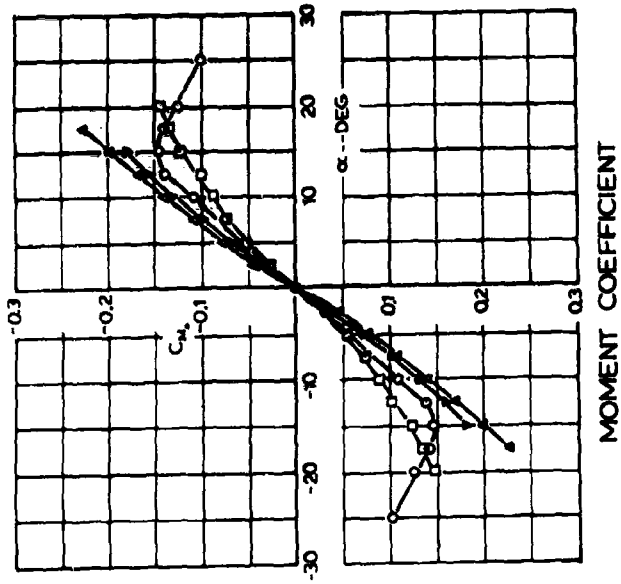

SYMBOL	NOMINAL POROSITY
○	9-11
□	60-90
△	120
▽	194

**FIG-8 AERODYNAMIC COEFFICIENTS VS
ANGLE OF ATTACK FOR CROSS TYPE
PARACHUTES OF VARIOUS NOMINAL POROSITIES
(W/L=264, GEOMETRIC POROSITY 41.7%)
BASED ON S_p AND REYNOLDS NO. $\approx 4.5 \times 10^5$**

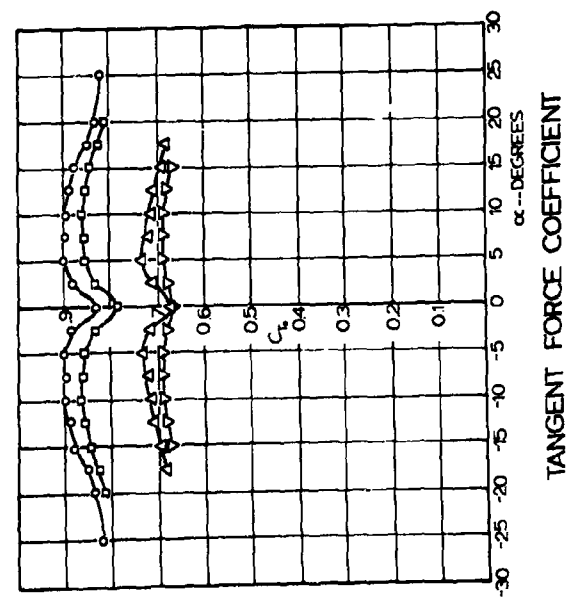

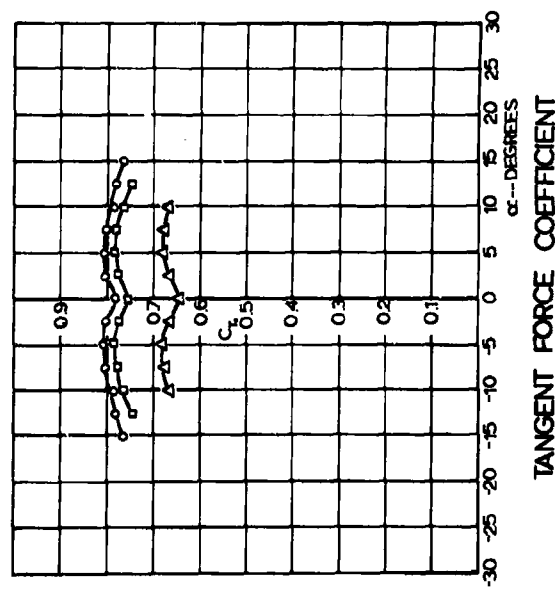
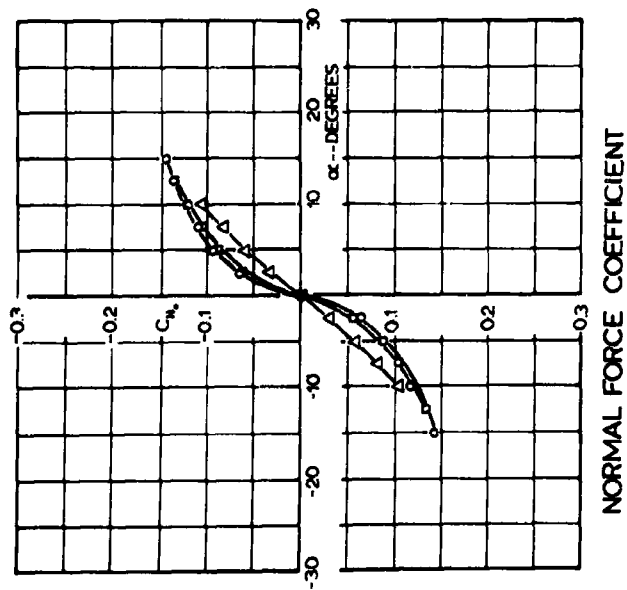
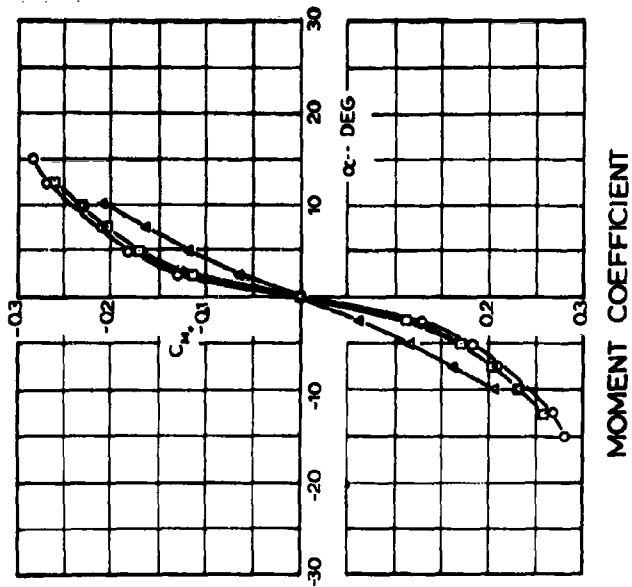

SYMBOL	NOMINAL POROSITY
○	9-11
□	60-90
△	120

FIG-9 AERODYNAMIC COEFFICIENTS VS
ANGLE OF ATTACK FOR CROSS TYPE
PARACHUTES OF VARIOUS NOMINAL POROSITIES
(W/L=194, GEOMETRIC POROSITY 55.3%)

BASED ON S_p AND REYNOLDS NO. $\approx 45 \times 10^5$

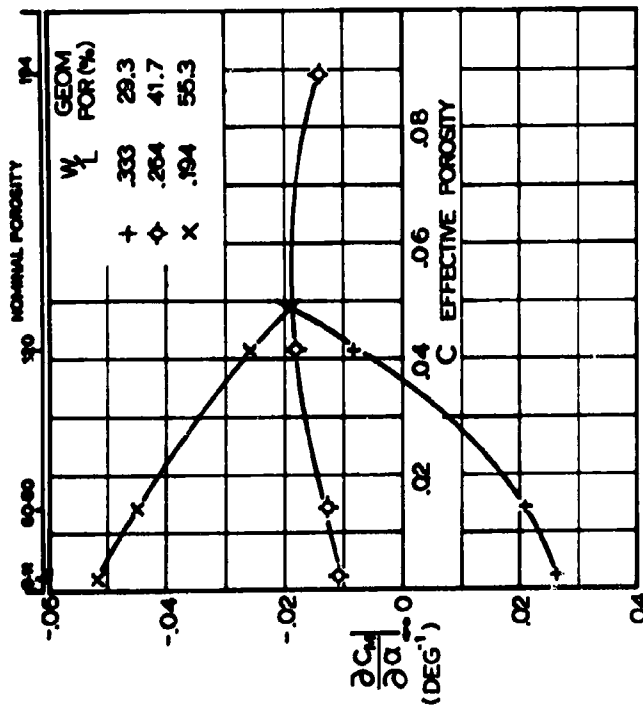

FIG 10. SLOPE OF MOMENT COEFFICIENT CURVE AT ZERO ANGLE OF ATTACK AS A FUNCTION OF EFFECTIVE POROSITY AT VARIOUS W/L VALUES

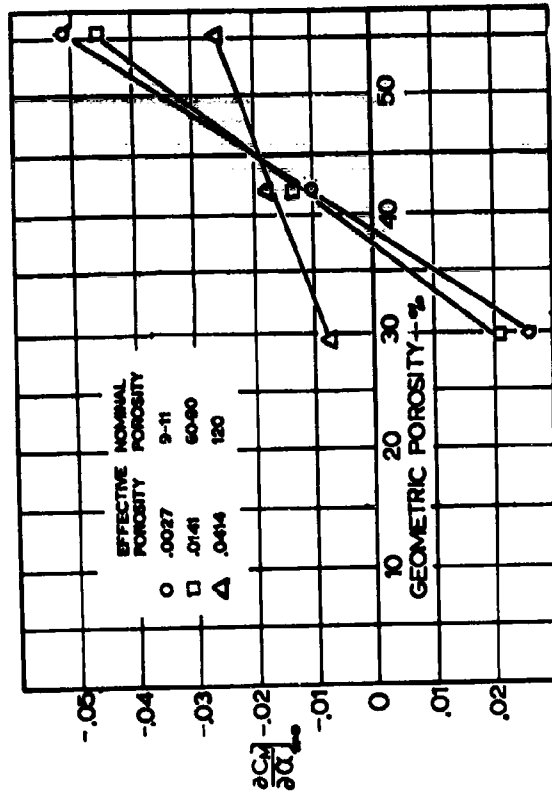

FIG 11. SLOPE OF MOMENT COEFFICIENT CURVE AT ZERO ANGLE OF ATTACK AS A FUNCTION OF GEOMETRIC POROSITY FOR CROSS PARACHUTES AT VARIOUS EFFECTIVE POROSITIES

TABLE 2. STABILITY AND DRAG CHARACTERISTICS OF CROSS PARACHUTES IN FREE STREAM

$\frac{W}{L}$	Nominal Porosity	Geometric Porosity	Effective Porosity C	α_{stable} (degrees)	$C_{T\alpha}$ stable	$\left. \frac{dC_M}{d\alpha} \right _{\alpha=0}$ deg ⁻¹
FREE STREAM						
.333	9 - 11	29.3%	.0027	$\pm 16^\circ$.86	+ .026
.333	60 - 90	29.3%	.0141	$\pm 13^\circ$.83	+ .021
.333	120	29.3%	.0414	0	.75	- .008
.264	9 - 11	41.7%	.0027	0	.84	- .011
.264	60 - 90	41.7%	.0141	0	.79	- .013
.264	120	41.7%	.0414	0	.67	- .018
.264	194	41.7%	.0893	0	.67	- .014
.194	9 - 11	55.3%	.0027	0	.78	- .052
.194	60 - 90	55.3%	.0141	0	.76	- .045
.194	120	55.3%	.0414	0	.64	- .026

B. Aerodynamic Characteristics of the Cross Parachute in the Wake of the A-21 Cargo Container

As a result of stability and drag considerations, three parachutes were chosen for investigation in the wake of A-21 cargo container models. They are $W/L = 0.264$ with nominal porosities of 60 - 90 and 194 ft³/ft²-min, and $W/L = .194$ with a nominal porosity of 60 - 90 ft³/ft²-min.

Each of these parachutes was tested with each of the forebody - riser length combinations discussed previously. The aerodynamic coefficients are presented as a function of angle of attack in Figs 12, 13 and 14, each figure representing a different forebody - riser length combination. In general,

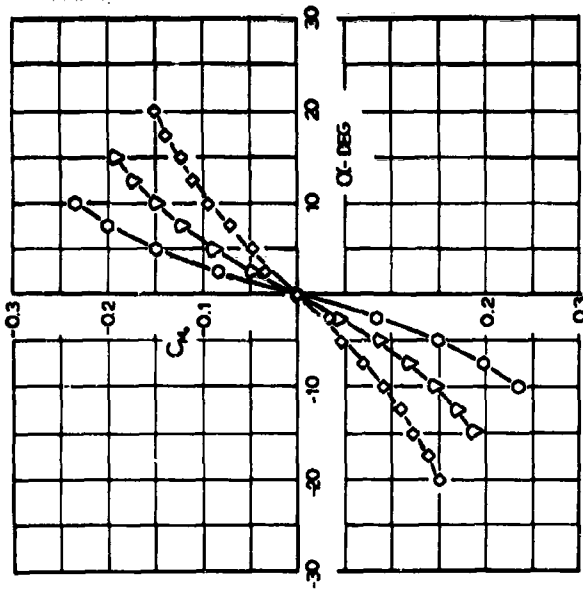

MOMENT COEFFICIENT

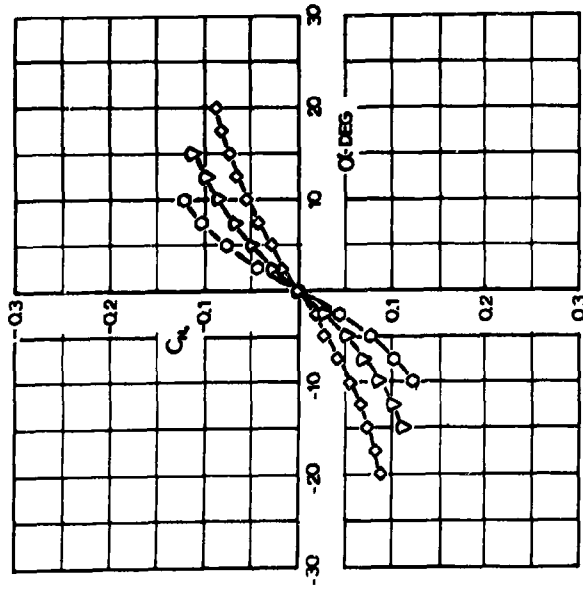

NORMAL FORCE COEFFICIENT

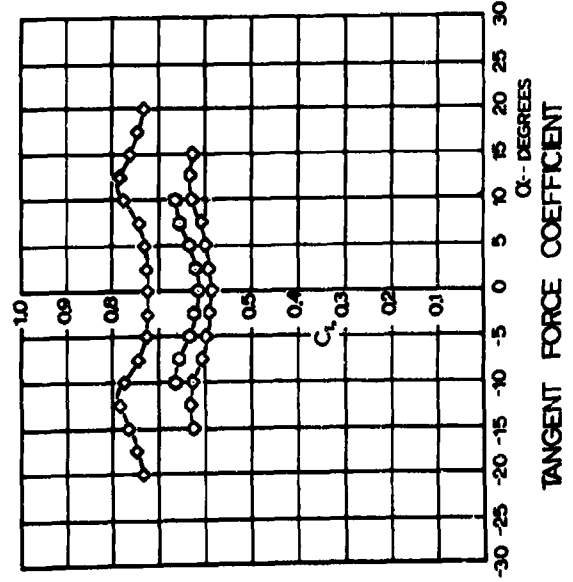

TANGENT FORCE COEFFICIENT

SYMBOL	W/L	NOMINAL POROSITY	A/S	EFFECTIVE POROSITY
○	.194	60-90	.146	.0141
◇	.264	60-90	.112	.0141
◊	.264	194	.112	.0803

FIG 12 AERODYNAMIC COEFFICIENTS VS ANGLE OF ATTACK FOR CROSS PARACHUTES WITH A-21 FOREBODY; (B/L=.276 AND RISER LENGTH=.80L)

BASED ON S_p AND REYNOLDS NO. $\approx 4.5 \times 10^5$

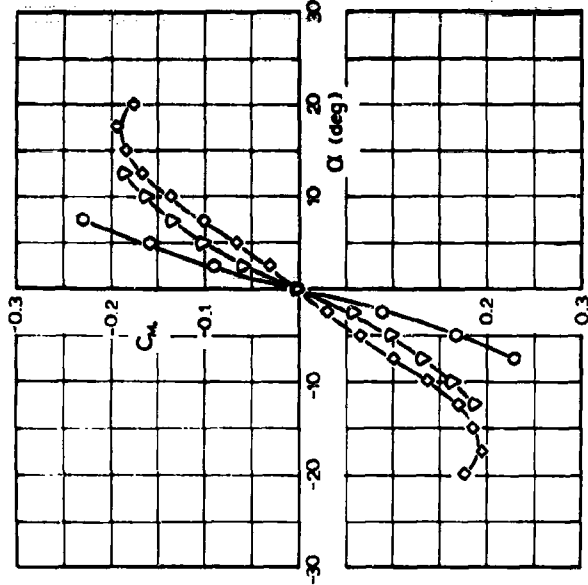

NORMAL FORCE COEFFICIENT

MOMENT COEFFICIENT

SYMBOL	WL	NOMINAL POROSITY	A/S ₀	EFFECTIVE POROSITY
○	.194	60-90	.146	.0141
◇	.264	60-90	.112	.0141
△	.264	194	.112	.0693

FIG 13 AERODYNAMIC COEFFICIENTS VS ANGLE OF ATTACK FOR CROSS PARACHUTES WITH A-21' FOREBODY, (DL-278 AND RSR LENGTH-.14L) BASED ON S₀ AND REYNOLDS NO 1.45x10⁵

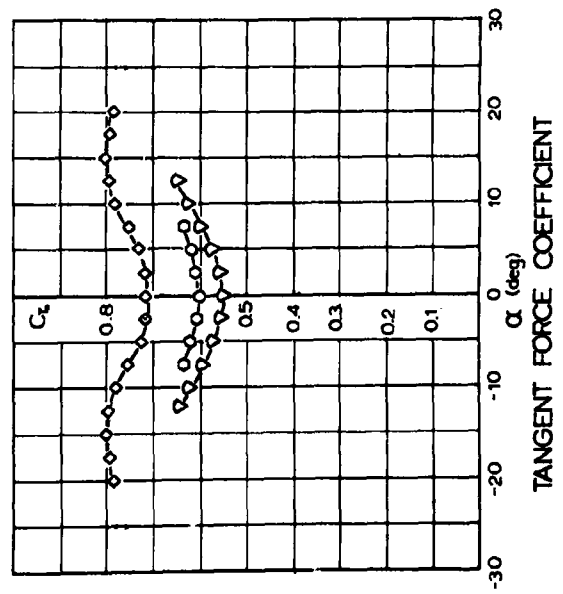

TANGENT FORCE COEFFICIENT

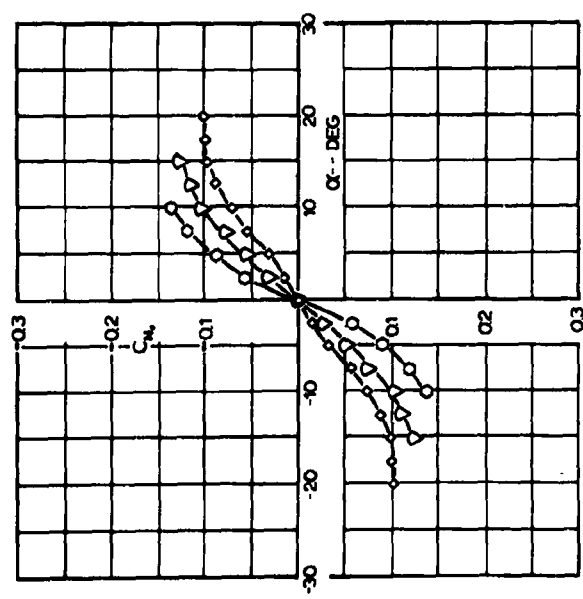
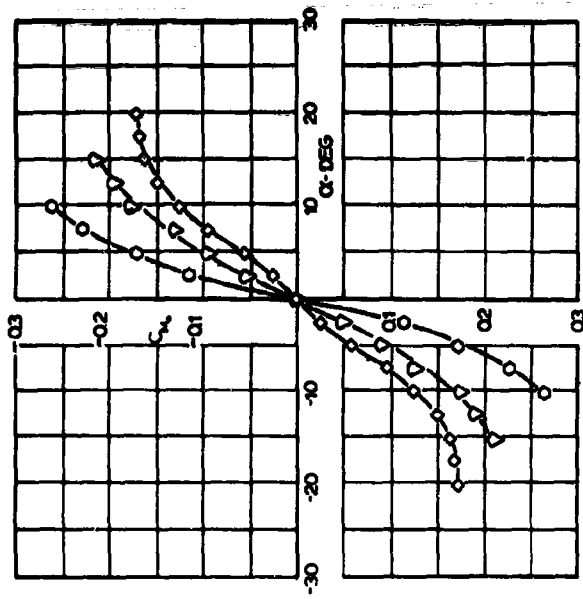

NORMAL FORCE COEFFICIENT

MOMENT COEFFICIENT

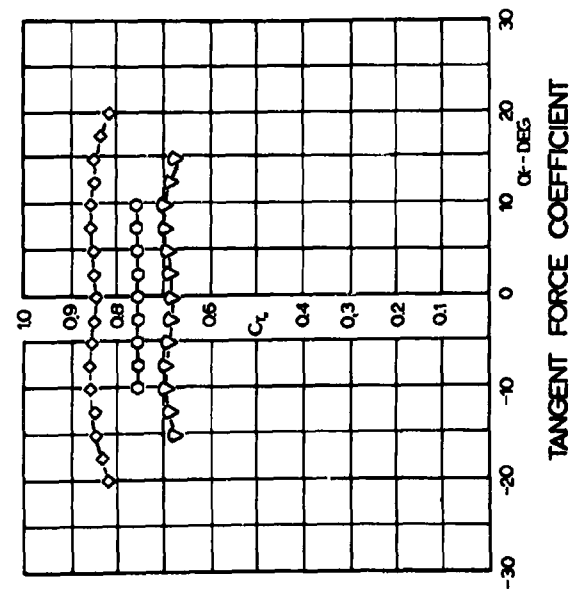

SYMBOL	W/L	NOMINAL POROSITY	A/S	EFFECTIVE POROSITY
○	194	60-90	.024	.0141
◇	264	60-90	.018	.0141
◊	264	194	.018	.0888

FIG 14 AERODYNAMIC COEFFICIENTS VS ANGLE OF ATTACK FOR CROSS PARACHUTES WITH A-21 FOREBODY (b/L=.112 AND RISER LENGTH=.06 L) BASED ON S₀ AND REYNOLDS NO. = 4.5 x 10⁵

the stability of the parachute is changed only slightly by the presence of a forebody. For the forebody configuration with $b/L = .278$, little change is noted as the riser length is varied from $.80L$ to $.14L$. Also, little stability change is noted as the relative size of the forebody is reduced from $b/L = .278$ to $b/L = .112$. The tangent force coefficients of the parachutes decrease significantly for all three parachutes in the region of $\alpha = 0^\circ$ for the forebody tests with $b/L = .278$. However, for the forebody tests with $b/L = .112$, tangent force coefficients vary little from free stream values. Significant results of the wake studies are summarized in Table 3. The aerodynamic coefficients from the free stream and wake studies are tabulated in the appendix.

TABLE 3. STABILITY AND DRAG CHARACTERISTICS OF CROSS PARACHUTE WITH A-21 FOREBODY

$\frac{W}{L}$	Nominal Porosity	Geom. Por. %	Effective Porosity C	$\frac{A}{S_0}$	α_{stable} (Degrees)	$C_{T\alpha}$ stable	$\left. \frac{dC_M}{d\alpha} \right]_{\alpha=0}$ deg ⁻¹
$b/L = .278; .80 L$ Riser							
.194	60 - 90	55.3	.0141	.146	0	.62	- .034
.264	60 - 90	41.7	.0141	.112	0	.72	- .014
.264	194	41.7	.0839	.112	0	.59	- .018
$b/L = .278, .14 L$ Riser							
.194	60 - 90	55.3	.0141	.146	0	.62	- .035
.264	60 - 90	41.7	.0141	.112	0	.72	- .012
.264	194	41.7	.0839	.112	0	.59	- .023
$b/L = .112, .06 L$ Riser							
.194	60 - 90	55.3	.0141	.024	0	.76	- .045
.264	60 - 90	41.7	.0141	.018	0	.83	- .010
.264	194	41.7	.0839	.018	0	.67	- .020

C. Comparison of Full Scale and Model Tests

Full scale drop tests on the Cross parachute have been conducted by government agencies to evaluate this type of parachute.

The U. S. Air Force has conducted a drop test program (Ref 5) using a 13.6 ft nominal diameter parachute with loads ranging from approximately 75 lbs to 232 lbs. In these tests the measured drag coefficient varied from 0.69 to 0.44 with a canopy loading of .52 lb/ft² to 1.60 lb/ft², respectively.

A direct comparison of this data with the wind tunnel model data is not readily possible, since several characteristics of the full scale system are not known. The cloth porosity of the canopy and the dimensions of the load, two parameters which will directly influence the drag coefficient, are not specified.

However, in general, it appears that the values of drag coefficient measured in the wind tunnel are somewhat higher than those experienced in these full scale tests.

Limited test results obtained from the U. S. Army Quartermaster Corps, Natick, Massachusetts, indicate a drag coefficient for a 16 ft nominal diameter Cross parachute to be in the order of 0.55. These studies were conducted with canopy loads producing an equilibrium velocity of 130 ft/sec, approximately double the highest velocity recorded in Ref 5 above. Again, certain pertinent canopy characteristics and loading information was not specified.

It appears that with the generally observed increase in drag coefficient with decreasing canopy loads, the Army test data would agree with the wind tunnel data contained in this report. Unfortunately, it is still not known why the effective drag coefficient depends on the canopy loading.

The drag coefficient obtained from full scale tests, as well as those from the subsonic wind tunnel, are shown in Fig 15.

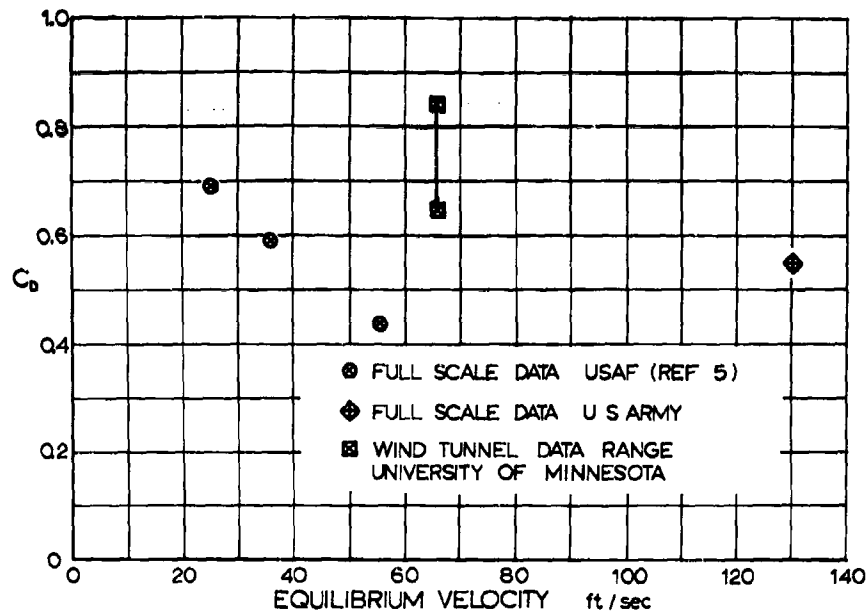

FIG 15. DRAG COEFFICIENT AS A FUNCTION OF EQUILIBRIUM VELOCITY FOR SEVERAL FULL SCALE AND WIND TUNNEL TESTS

It appears that a direct comparison of wind tunnel and full scale data cannot be made until all related circumstances are known.

Furthermore, the quoted wind tunnel data is strictly related to a zero angle of attack, whereas the exact angle of attack of the parachute in full size drop tests is not known.

Also, the drag coefficients extracted from full size tests are all obtained under conditions of the presence of a forebody. Since there is no information available on the forebody employed in the full size drop tests, one cannot really compare the two sets of data.

In summary, it is suggested that the presented wind tunnel data be considered as correct in order of magnitude, but that possibly of more importance is the relative relationship of the wind tunnel data results to each other.

4. SUMMARY

Ten Cross parachutes were studied in a wind tunnel program to fulfill the following objectives:

- 1) Establish the drag and stability characteristics of this type of parachute over a range of angle of attack
- 2) Determine the effect of canopy geometry and cloth porosity on these aerodynamic coefficients
- 3) Determine the effect of the presence of a wake producing body upstream on the aerodynamic coefficients.

The results show a general decline of tangent force with increased cloth porosity as is generally the case.

The general trend toward greater stability with increasing cloth porosity is noted for canopy configurations with less than about 44 per cent geometric porosity. However, above this value a reversal in the trend has been found.

Of all the configurations studied, only two appeared to be obviously undesirable from the standpoint of stability, and both are of the largest width to length ratio ($W/L = 0.333$).

The low porosity model, 9 - 11 nominal porosity, has the greatest range of instability, $\pm 16^\circ$ about zero angle of attack, and the medium porosity model, 60 - 90 nominal porosity, has an instability range of $\pm 13^\circ$ about the zero angle of attack.

In the wake of an A-21 cargo container, the stability of the parachute remains at about its free stream value. The tangent force coefficient is reduced by an appreciable amount in the wake of the larger A-21 forebody, but essentially obtains its free stream value as the size of the container is decreased to $b/L = .112$.

With the exception of the unstable configurations, most models showed desirable parachute characteristics in the wind tunnel. The three models used for testing behind the A-21 container as a forebody were deemed to have had the best overall performance in singly suspended studies.

APPENDIX

AERODYNAMIC COEFFICIENTS OF CROSS PARACHUTES IN FREE STREAM
AND IN THE WAKE OF AN A-21 CARGO CONTAINER

TABLE 4. AERODYNAMIC COEFFICIENTS OF CROSS PARACHUTES, WL-333

α	C_T	C_N	C_M
Nominal Porosity 9 - 11 ft ³ /ft ² -min Effective Porosity .0027			
0	.86	0	0
+ 2½	.91	± .04	± .07
+ 5	.93	± .04	± .06
+ 7½	.93	± .04	± .06
+ 10	.95	± .03	± .04
+ 12½	.95	± .02	± .03
+ 15	.95	± .01	± .02
+ 17½	.94	± .01	± .01
+ 20	.94	± .03	± .04
+ 25	.93	± .04	± .06
+ 30	.92	± .04	± .06
Nominal Porosity 60 - 90 ft ³ /ft ² -min Effective Porosity .0141			
0	.83	0	0
+ 2½	.87	± .03	± .05
+ 5	.90	± .03	± .05
+ 7½	.90	± .02	± .04
+ 10	.91	± .01	± .02
+ 12½	.90	± .01	± .01
+ 15	.90	± .02	± .03
+ 17½	.90	± .03	± .05
+ 20	.89	± .04	± .07
+ 25	.86	± .06	± .09
+ 30	.85	± .05	± .08
Nominal Porosity 120 ft ³ /ft ² -min Effective Porosity .0414			
0	.75	0	0
+ 2½	.77	± .01	± .02
+ 5	.77	± .03	± .04
+ 7½	.77	± .03	± .05
+ 10	.78	± .04	± .06
+ 12½	.77	± .05	± .08
+ 15	.76	± .06	± .10
+ 17½	.75	± .08	± .12
+ 20	.74	± .09	± .14
+ 25	.70	± .09	± .14

TABLE 5. AERODYNAMIC COEFFICIENTS OF CROSS PARACHUTES WITH WL=264

α	C_T	C_N	C_M
Nominal Porosity 9 - 11 ft ³ /ft ² -min Effective Porosity .0027			
0	.84	0	0
+ 2½	.89	± .02	± .03
+ 5	.90	± .03	± .05
+ 7½	.90	± .05	± .08
+ 10	.90	± .07	± .11
+ 12½	.89	± .08	± .14
+ 15	.88	± .09	± .15
+ 17½	.85	± .08	± .14
+ 20	.84	± .08	± .13
+ 25	.82	± .06	± .10
Nominal Porosity 60 - 90 ft ³ /ft ² -min Effective Porosity .0141			
0	.79	0	0
+ 2½	.84	± .02	± .03
+ 5	.86	± .03	± .05
+ 7½	.86	± .04	± .07
+ 10	.87	± .05	± .09
+ 12½	.86	± .06	± .10
+ 15	.85	± .07	± .12
+ 17½	.83	± .08	± .13
+ 20	.82	± .09	± .14
Nominal Porosity 120 ft ³ /ft ² -min Effective Porosity .0414			
0	.67	0	0
+ 2½	.72	± .03	± .04
+ 5	.74	± .05	± .08
+ 7½	.72	± .06	± .11
+ 10	.72	± .08	± .14
+ 12½	.71	± .10	± .17
+ 15	.70	± .12	± .20
+ 17½	.68	± .13	± .23
Nominal Porosity 194 ft ³ /ft ² -min Effective Porosity .0893			
0	.67	0	0
+ 2½	.68	± .02	± .03
+ 5	.69	± .04	± .07
+ 7½	.69	± .06	± .10
+ 10	.69	± .08	± .13
+ 12½	.68	± .09	± .16
+ 15	.68	± .11	± .18

TABLE 6. AERODYNAMIC COEFFICIENTS OF CROSS PARACHUTES WITH WL=194

α	C_T	C_N	C_M
Nominal Porosity 9 - 11 ft ³ /ft ² -min Effective Porosity .0027			
0	.78	0	0
+ 2½	.80	± .07	± .13
+ 5	.81	± .08	± .16
+ 7½	.80	± .11	± .21
+ 10	.78	± .12	± .23
+ 12½	.79	± .14	± .26
+ 15	.76	± .14	± .28
Nominal Porosity 60 - 90 ft ³ /ft ² -min Effective Porosity .0141			
0	.76	0	0
+ 2½	.78	± .06	± .11
+ 5	.78	± .09	± .17
+ 7½	.78	± .11	± .21
+ 10	.77	± .12	± .23
+ 12½	.75	± .13	± .26
Nominal Porosity 120 ft ³ /ft ² -min Effective Porosity .0414			
0	.64	0	0
+ 2½	.67	± .03	± .06
+ 5	.68	± .06	± .12
+ 7½	.67	± .08	± .16
+ 10	.66	± .11	± .21

TABLE 7. AERODYNAMIC COEFFICIENTS FOR CROSS PARACHUTES WITH A-21 FOREBODY b/L=.278 AND .80L RISER

α	C_{T0}	C_{N0}	C_{M0}
$W/L = .194$ Nom. Pos. 60-90 ft ³ /ft ² -min			
0	.61	0	0
$\pm 2\frac{1}{2}$.62	$\mp .04$	$\mp .09$
± 5	.64	$\mp .08$	$\mp .15$
$\pm 7\frac{1}{2}$.65	$\mp .10$	$\mp .20$
± 10	.66	$\mp .12$	$\mp .24$
$W/L = .264$ Nom. Pos. 60-90 ft ³ /ft ² -min			
0	.72	0	0
$\pm 2\frac{1}{2}$.72	$\mp .02$	$\mp .03$
± 5	.72	$\mp .03$	$\mp .05$
$\pm 7\frac{1}{2}$.74	$\mp .04$	$\mp .07$
± 10	.78	$\mp .06$	$\mp .09$
$\pm 12\frac{1}{2}$.78	$\mp .07$	$\mp .11$
± 15	.76	$\mp .07$	$\mp .12$
$\pm 17\frac{1}{2}$.75	$\mp .08$	$\mp .14$
± 20	.75	$\mp .09$	$\mp .15$
$W/L = .264$ Nom. Pos. 194 ft ³ /ft ² -min			
0	.59	0	0
$\pm 2\frac{1}{2}$.59	$\mp .03$	$\mp .04$
± 5	.60	$\mp .05$	$\mp .09$
$\pm 7\frac{1}{2}$.61	$\mp .07$	$\mp .12$
± 10	.63	$\mp .09$	$\mp .15$
$\pm 12\frac{1}{2}$.63	$\mp .10$	$\mp .17$
± 15	.62	$\mp .11$	$\mp .19$

TABLE 8. AERODYNAMIC COEFFICIENTS FOR CROSS PARACHUTES WITH A-21 FOREBODY, b/L=.278 AND .14L RISER

α	C_{T0}	C_{N0}	C_{M0}
$W/L = .194$ Nom. Pos. 60-90 ft ³ /ft ² -min			
0	.60	0	0
$\pm 2\frac{1}{2}$.60	$\mp .05$	$\mp .09$
± 5	.62	$\mp .09$	$\mp .17$
$\pm 7\frac{1}{2}$.64	$\mp .12$	$\mp .23$
$W/L = .264$ Nom. Pos. 60-90 ft ³ /ft ² -min			
0	.72	0	0
$\pm 2\frac{1}{2}$.72	$\mp .02$	$\mp .03$
± 5	.73	$\mp .04$	$\mp .07$
$\pm 7\frac{1}{2}$.75	$\mp .06$	$\mp .10$
± 10	.78	$\mp .08$	$\mp .14$
$\pm 12\frac{1}{2}$.80	$\mp .10$	$\mp .17$
± 15	.80	$\mp .11$	$\mp .18$
$\pm 17\frac{1}{2}$.80	$\mp .12$	$\mp .20$
± 20	.79	$\mp .11$	$\mp .18$
$W/L = .264$ Nom. Pos. 194 ft ³ /ft ² -min			
0	.55	0	0
$\pm 2\frac{1}{2}$.56	$\mp .03$	$\mp .06$
± 5	.57	$\mp .07$	$\mp .10$
$\pm 7\frac{1}{2}$.60	$\mp .08$	$\mp .14$
± 10	.63	$\mp .10$	$\mp .16$
$\pm 12\frac{1}{2}$.64	$\mp .11$	$\mp .19$

TABLE 9. AERODYNAMIC COEFFICIENTS FOR CROSS PARACHUTES WITH A-21 FOREBODY, b/L=.112 AND .06L RISER

α	C_{T0}	C_{N0}	C_{M0}
$W/L = .194$ Nom. Pos. 60-90 ft ³ /ft ² -min			
0	.76	0	0
$\pm 2\frac{1}{2}$.75	$\mp .06$	$\mp .11$
± 5	.76	$\mp .09$	$\mp .17$
$\pm 7\frac{1}{2}$.75	$\mp .12$	$\mp .23$
± 10	.75	$\mp .14$	$\mp .26$
$W/L = .264$ Nom. Pos. 60-90 ft ³ /ft ² -min			
0	.83	0	0
$\pm 2\frac{1}{2}$.85	$\mp .02$	$\mp .02$
± 5	.86	$\mp .03$	$\mp .06$
$\pm 7\frac{1}{2}$.86	$\mp .06$	$\mp .10$
± 10	.86	$\mp .07$	$\mp .12$
$\pm 12\frac{1}{2}$.85	$\mp .09$	$\mp .15$
± 15	.84	$\mp .10$	$\mp .16$
$\pm 17\frac{1}{2}$.84	$\mp .10$	$\mp .17$
± 20	.82	$\mp .10$	$\mp .17$
$W/L = .264$ Nom. Pos. 194 ft ³ /ft ² -min			
0	.67	0	0
$\pm 2\frac{1}{2}$.68	$\mp .03$	$\mp .05$
± 5	.69	$\mp .05$	$\mp .09$
$\pm 7\frac{1}{2}$.70	$\mp .08$	$\mp .13$
± 10	.70	$\mp .10$	$\mp .18$
$\pm 12\frac{1}{2}$.69	$\mp .11$	$\mp .19$
± 15	.67	$\mp .12$	$\mp .21$

REFERENCES

1. Performance of and Design Criteria for Deployable Aerodynamic Decelerators, ASD-TR-61-579, December, 1963.
2. Heinrich, H. G. and Haak, E. L.: Stability and Drag of Parachutes with Varying Effective Porosity, ASD TR 62-100, December, 1961.
3. Heinrich, H. G.: The Effective Porosity of Parachute Cloth, Reprint from "Zeitschrift fur Flugwissenschaften" (Journal of Flight Sciences), Vol. 11, No. 10, 1963, Braunschweig, Germany.
4. Heinrich, H. G. and Ibrahim, S. K.: Aerodynamic Characteristics of the Parachute Stabilized A-21 Cargo Container, University of Minnesota, to be published as WADC Technical Report.
5. U. S. Air Force Air Material Command Technical Drawing No. 51C7071, Riser - Cargo Parachute Canopy, January 23, 1951.
6. Aeronautical Systems Division, Air Force Systems Command Technical Memorandum, Technical Evaluation of the French Cross Parachute, ASNM-TM-6321, August, 1963.

DOCUMENT CONTROL DATA - R&D

(Security classification of title, body of abstract and indexing annotation must be entered when the overall report is classified)

1. ORIGINATING ACTIVITY (Corporate author) University of Minnesota Minneapolis 14, Minnesota		2a. REPORT SECURITY CLASSIFICATION Unclassified	
		2b. GROUP n/a	
3. REPORT TITLE Drag and Stability of Cross Type Parachutes			
4. DESCRIPTIVE NOTES (Type of report and inclusive dates) Final Report 15 April 1963 - May 1964			
5. AUTHOR(S) (Last name, first name, initial) Niccum, R. J. Haak, F. L. Gutenkauf, Robert			
6. REPORT DATE February 1965		7a. TOTAL NO. OF PAGES 30	7b. NO. OF REFS 6
8a. CONTRACT OR GRANT NO. AF33(657)-11184		9a. ORIGINATOR'S REPORT NUMBER(S) FDL-TDR-64-155	
b. PROJECT NO. 6065		9b. OTHER REPORT NO(S) (Any other numbers that may be assigned this report) none	
c. 606503			
d.			
10. AVAILABILITY/LIMITATION NOTICES Qualified users may obtain copies of this report from Defense Documentation Center. Foreign announcement and dissemination of this report is not authorized. DDC release to CFSTI is not authorized.			
11. SUPPLEMENTARY NOTES none		12. SPONSORING MILITARY ACTIVITY AFFDL (FDFR) WPAFB, Ohio	
13. ABSTRACT Wind tunnel studies have been performed on several configurations of the Cross parachute. Both the canopy geometry and the cloth porosity have been varied to provide data over the entire range for which the canopy may be used. In addition, the performance of these canopies in the wake of a forebody has been evaluated. This report contains the results of three-component studies on these models as well as a discussion of the canopy performance in light of the tests performed.			

Security Classification

14. KEY WORDS	LINK A		LINK B		LINK C	
	ROLE	WT	ROLE	WT	ROLE	WT
Cross Type Parachute Drag Stability A-21 Cargo Container Wind Tunnel Tests						

INSTRUCTIONS

1. **ORIGINATING ACTIVITY:** Enter the name and address of the contractor, subcontractor, grantee, Department of Defense activity or other organization (*corporate author*) issuing the report.

2a. **REPORT SECURITY CLASSIFICATION:** Enter the overall security classification of the report. Indicate whether "Restricted Data" is included. Marking is to be in accordance with appropriate security regulations.

2b. **GROUP:** Automatic downgrading is specified in DoD Directive 5200.10 and Armed Forces Industrial Manual. Enter the group number. Also, when applicable, show that optional markings have been used for Group 3 and Group 4 as authorized.

3. **REPORT TITLE:** Enter the complete report title in all capital letters. Titles in all cases should be unclassified. If a meaningful title cannot be selected without classification, show title classification in all capitals in parenthesis immediately following the title.

4. **DESCRIPTIVE NOTES:** If appropriate, enter the type of report, e.g., interim, progress, summary, annual, or final. Give the inclusive dates when a specific reporting period is covered.

5. **AUTHOR(S):** Enter the name(s) of author(s) as shown on or in the report. Enter last name, first name, middle initial. If military, show rank and branch of service. The name of the principal author is an absolute minimum requirement.

6. **REPORT DATE:** Enter the date of the report as day, month, year; or month, year. If more than one date appears on the report, use date of publication.

7a. **TOTAL NUMBER OF PAGES:** The total page count should follow normal pagination procedures, i.e., enter the number of pages containing information.

7b. **NUMBER OF REFERENCES:** Enter the total number of references cited in the report.

8a. **CONTRACT OR GRANT NUMBER:** If appropriate, enter the applicable number of the contract or grant under which the report was written.

8b, 8c, & 8d. **PROJECT NUMBER:** Enter the appropriate military department identification, such as project number, subproject number, system numbers, task number, etc.

9a. **ORIGINATOR'S REPORT NUMBER(S):** Enter the official report number by which the document will be identified and controlled by the originating activity. This number must be unique to this report.

9b. **OTHER REPORT NUMBER(S):** If the report has been assigned any other report numbers (*either by the originator or by the sponsor*), also enter this number(s).

10. **AVAILABILITY/LIMITATION NOTICES:** Enter any limitations on further dissemination of the report, other than those

imposed by security classification, using standard statements such as:

- (1) "Qualified requesters may obtain copies of this report from DDC."
- (2) "Foreign announcement and dissemination of this report by DDC is not authorized."
- (3) "U. S. Government agencies may obtain copies of this report directly from DDC. Other qualified DDC users shall request through _____."
- (4) "U. S. military agencies may obtain copies of this report directly from DDC. Other qualified users shall request through _____."
- (5) "All distribution of this report is controlled. Qualified DDC users shall request through _____."

If the report has been furnished to the Office of Technical Services, Department of Commerce, for sale to the public, indicate this fact and enter the price, if known.

11. **SUPPLEMENTARY NOTES:** Use for additional explanatory notes.

12. **SPONSORING MILITARY ACTIVITY:** Enter the name of the departmental project office or laboratory sponsoring (*paying for*) the research and development. Include address.

13. **ABSTRACT:** Enter an abstract giving a brief and factual summary of the document indicative of the report, even though it may also appear elsewhere in the body of the technical report. If additional space is required, a continuation sheet shall be attached.

It is highly desirable that the abstract of classified reports be unclassified. Each paragraph of the abstract shall end with an indication of the military security classification of the information in the paragraph, represented as (TS), (S), (C), or (U).

There is no limitation on the length of the abstract. However, the suggested length is from 150 to 225 words.

14. **KEY WORDS:** Key words are technically meaningful terms or short phrases that characterize a report and may be used as index entries for cataloging the report. Key words must be selected so that no security classification is required. Identifiers, such as equipment model designation, trade name, military project code name, geographic location, may be used as key words but will be followed by an indication of technical context. The assignment of links, rules, and weights is optional.