

UNCLASSIFIED

AD NUMBER
AD460522
NEW LIMITATION CHANGE
TO Approved for public release, distribution unlimited
FROM Distribution authorized to U.S. Gov't. agencies and their contractors; Administrative/Operational Use; Mar 1965. Other requests shall be referred to Bureau of Yards and Docks, Attn: Navy Department, Washington, DC 20390.
AUTHORITY
USNCBC ltr, 24 Oct 1974

THIS PAGE IS UNCLASSIFIED

UNCLASSIFIED

AD 460522

DEFENSE DOCUMENTATION CENTER

FOR

SCIENTIFIC AND TECHNICAL INFORMATION

CAMERON STATION ALEXANDRIA, VIRGINIA



UNCLASSIFIED

NOTICE: When government or other drawings, specifications or other data are used for any purpose other than in connection with a definitely related government procurement operation, the U. S. Government thereby incurs no responsibility, nor any obligation whatsoever; and the fact that the Government may have formulated, furnished, or in any way supplied the said drawings, specifications, or other data is not to be regarded by implication or otherwise as in any manner licensing the holder or any other person or corporation, or conveying any rights or permission to manufacture, use or sell any patented invention that may in any way be related thereto.

CATALOGED BY: DDC

AS AD NO. 460522

FOR OFFICIAL USE ONLY

Technical Note N-588 (Revised)

TEST PROCEDURES FOR PROTECTIVE SHELTERS

BY

W. R. Nehlsen

15 March 1965

4 6 0 5 2 2

U. S. NAVAL CIVIL ENGINEERING LABORATORY
Port Hueneme, California

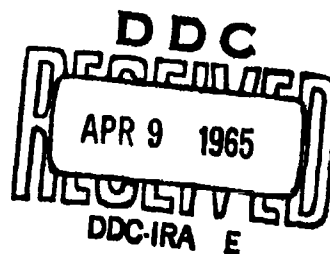

TEST PROCEDURES FOR PROTECTIVE SHELTERS

Y-F011-05-03-401(g)

Type B

by

W. R. Nehlsen

ABSTRACT

Protective shelters must be maintained in good condition to function properly when required. This report lists equipment that should be checked annually or more often to ensure that shelters can operate as designed.

Procedures for testing several special items of shelter equipment are also given.

**QUALIFIED REQUESTORS MAY OBTAIN
COPIES OF THIS DOCUMENT FROM DDC.**

I. INTRODUCTION

Protective shelters and facilities may be needed on a very brief notice and routine periodic inspections of operational readiness are necessary to insure proper function at the time of need. Items intended for an annual general inspection are given in the check list in sections III through XI. Items requiring more frequent inspections appear on the check list with a notation of recommended inspection intervals.

Shelters and facilities that are in routine use will require in each case, preparation of an individual inspection and maintenance procedure, combining this check list with the schedule of routine preventive maintenance services.

The check list specifies the items and functions to be inspected. Additional information on testing methods is included when inspection requires special methods that may not be familiar to base Public Works personnel. The Appendix lists test equipment needed for normal checking procedures. All items on these lists will not necessarily apply to every shelter to be inspected. Reference to NAVDOCKS P-81¹ will assist inspection personnel in identifying various components.

A list of personnel that usually are available in civilian or military occupations at shore stations, who can provide assistance in making one or more of the suggested checks is also included.

II. INSPECTION DOCUMENTS

Wherever possible, the design specifications and construction drawings of the structure should be obtained prior to inspection. These will show utility connections, the location of underground pipes and tanks near the shelter, and may indicate the intended functional parameters of the shelter equipment. Maintenance schedules, if used, will also yield valuable information on the condition of the shelter. References 2 through 7 will assist in making a thorough inspection.

III. OUTSIDE INSPECTION

The outside inspection covers:

A. Earth Cover

1. Erosion
2. Settling
3. Drainage channels

B. Fill Pipes for Storage Tanks

1. Locks in place and in good condition
2. Keys available
3. Plainly marked as to contents in tank
4. No adverse corrosion

C. Utilities Connections and Condition

1. Power lines
2. Water
3. Sewer
4. Telephone
5. Fire alarm

D. Antennas

1. Guy wires and turnbuckles
2. Feedline
3. Standing waves on feedline

E. Vents and Blast Closure Outside Openings

1. Corrosion
2. Obstructions-windblown debris-bird nests

F. Escape Hatches

1. Corrosion
2. Obstructions

G. Entrance Passage

1. Cleanliness
2. Drainage

IV. INTERIOR STRUCTURE

The interior structure inspection covers:

A. Blast Doors

1. Swing free
2. Corrosion
3. Latch tight

B. Interior of Structural Shell

1. Water tightness
2. Corrosion
3. Cracks
4. Sagging
5. Bolt tightness

C. Floor

1. Drains
2. Cracks
3. Cleanliness
4. Signs of rodents or other pests (check monthly)

D. Equipment Shock Mounts

1. Adjustment
2. Condition of rubber
3. Dashpots - fluid leaks
4. Corrosion
5. Lubrication

E. Air Locks

1. Clothes chute
2. Air Regulator Valves - proper setting
3. Anti-backdraft Valves - swing freely

F. Lighting

1. Switches
2. Bulbs or tubes

V. ELECTRIC POWER SYSTEM

The electric power system inspection includes:

A. General

1. Switches and breakers (corrosion, dirt, etc.)
2. Connections
3. Insulation

B. Emergency Generator

1. Fuel storage - drain, flush, and refill. If gasoline, do on 6-months interval
2. Fuel lines - fittings
3. Batteries
4. Engine - do normal annual preventive maintenance schedule recommended by manufacturer
5. Switches and starting
6. Start and operate for at least 1/2 hour (recommended every 30 days)
7. Output (after all shelter equipment is checked and running, check voltage and amperage)

VI. AIR SUPPLY SYSTEMS

The air supply system inspection includes:

A. Blast Closure Valves

1. OCD Type, Army Chemical Corps M1 and other blast-actuated mechanical types. (See NAVDOCKS P-81, p 85-91.) These valves contain a spring loaded valve disc and stem. Proper operation depends on freedom of movement of disc and stem, a smooth seating surface, and good condition of spring. Partial disassembly of valve and connections will usually be necessary to inspect internal parts for corrosion and condition of sealing gaskets.
2. AMF Blast Closure with light flash activated closure mechanisms. (References 6 and 7 contain additional information on light flash activation circuits.)

a. These closures use a small explosive valve triggered by an electric circuit activated by a double light flash. The flash detector is located outside the shelter. The explosive valve and a high pressure air bottle are located in a control box inside the shelter. When triggered, the explosive valve admits pressurized air to a cylinder on the main closure shaft and the air pressure slams the closure shut. Each use requires replacement of the explosive valve. Extreme care is necessary in checking these closures.

b. First step in checking is to disconnect wires to explosive valve (see Figure 1) and put the 4-way valve in the control box to a position where no pressure can be transmitted to the valve. Then, inspect all parts of valve for corrosion and proper lubrication.

c. Air bottle pressure should be 1200 psi.

d. Check air system by opening by-pass shut-off valve and turning 4-way valve to position to close the main valve head. Be sure all personnel are clear of main valve head when this test is made.

e. Rotate 4-way valve to reopen position. Main valve head should reopen.

f. Close by-pass valve. Air bottle should be refilled to 1200 psi.

g. To check light detector condition without discharging the explosive valve, the wires into this valve should be left disconnected and an ammeter connected across the loose wires. When the light detector is activated, this meter should show 1 to 3 amps. To activate the light detector, two lights are required; one capable of emitting a high intensity flash of light and the other, a 250-watt heat lamp. A high intensity electronic type photoflash unit may serve for the flash source. These two light sources should be mounted about 12 inches from the detector and arranged so that both can be operated simultaneously. This will provide the double light impulse required since the photoflash discharge will be completed before the heat lamp filament has reached full brightness. The double light impulse is characteristic of

nuclear explosions. It may be necessary to move the photoflash unit even closer than one foot. It also may be necessary to switch on the heat lamp a fraction of a second before the photoflash so that the heat lamp filament is not too long delayed in reaching maximum brightness.

h. Reconnect wires, check air bottle pressure and 4-way valve position after all faults have been corrected.

3. Mosler Blast Closure with light flash activated closure mechanism

a. The Mosler blast closure valve system uses an electric solenoid valve instead of an explosive-squib valve to initiate the closing action. Figure 2 diagrams the Mosler valve construction and operating elements. A flash detector is located outside the shelter. When a characteristic double-pulse nuclear flash is detected, the flash sensor generates an electric signal to the control circuit, which in turn de-energizes the three-way solenoid valve. This bleeds air rapidly from the pilot cylinder through the solenoid valve vent. The loss of pressure in the pilot cylinder causes the dump valve to open immediately and release pressure from lower side of the actuator piston. Since there is still pressure on the upper side of the actuator piston, it moves rapidly downward to close the valve head. In the "ready" condition the air reservoir, the upper and lower parts of the actuator cylinder and the lower part of the pilot cylinder, all contain about 250 psi air pressure.

b. In checking the valve it is essential to remain clear of the valve head since it may slam shut without warning because of a power failure. The exact installation of control circuit and air supply lines to the air reservoir on the valve stem varies from shelter to shelter, so it is first necessary to inspect the installation carefully to determine how electrical and air hook-ups have been made. Multiple valve installations may have a central electrical control panel and an air compressor for recharging valve air reservoirs. The 3-way solenoid valve is located on the side of the actuator cylinder.

c. After the general layout of controls has been determined, block the valve head securely open and inspect the valve stem under the valve head for corrosion. This

stem should be rust free and lightly lubricated. Inspect other parts of the valve and its connections for damaging corrosion. Remove the blocking under the valve head before testing operation of the valve. Operation of valve can usually be checked with the open and close push-buttons provided at a control panel.

d. Operation of the entire flash detection system, the solenoid and the closure cylinders can be checked by setting up a simulated nuclear light pulse at the flash sensor. Arrange a high intensity electronic photoflash unit and a 250 watt heat lamp about 12 inches from the flash detector so that both lights can be operated simultaneously. This will provide a double light impulse since the photoflash discharge will be completed before the heat lamp filament has reached full brightness. Make sure all personnel are clear of the valve head and then operate the lights at the same time. If this does not actuate the valve it may be necessary to move the lamps closer and to switch the heat lamp on a fraction of a second before the photoflash in order to obtain the desired intensity and timing of the light pulse. The valve head should reopen when the solenoid valve is energized with the control system.

e. To check the air tightness of the pilot and actuating cylinder it is necessary to have a pressure gage installed in the air piping to the reservoir at the valve. Make sure there are no check valves between the reservoir and the gage. With the valve head open, the reservoir pressurized to 250 psi, and the external air supply shut-off, the valve air system should still be above 245 psi after 72 hours.

f. After completion of inspection make sure that all parts of the system are returned to normal readiness conditions.

B. Collective Protector

1. Prefilter

- a. Replace if dirty
- b. Check gaskets

2. Flexible ducting

a. Cracks and deterioration - if any, make temporary repair and plan to replace with sheet metal transitions.

b. Fastening

3. Control damper

a. Lubrication

b. Corrosion

4. Blower and motor or engine drive

a. Lubrication

b. Engine maintenance (exercise monthly)

c. Fastenings

5. Particulate and charcoal filters (preoperating check)

a. Visual inspection for cracks, sagging or deterioration (check as possible without disassembling unit)

b. Gasket condition

6. Air flow and pressurization. Establishment of the proper air flows and pressures in the ventilation system, the shelter area and the entrance airlocks is essential to the safety of the shelter. Since the air regulation system consists of a rather delicate balance between parts, it is usually a matter of some trial and error before proper conditions are achieved. The following procedures are aimed at achieving the necessary flows of purified air and shelter pressurization with the least difficulty, but several trials may be necessary to achieve a working balance of air flow and pressure adjustments.

a. Air flow through filters. The filter and blower system must be checked for proper volumes and pressures. If an inclined-vertical draft gage with about 10 inches of capacity and pressure taps are not installed on the filter and blower system, a permanent installation of these should be made prior to checking the blower-filter unit. Figure 3 shows the general requirements for this

installation. Before checking further, install new pre-filters if they are dirty. With the blower operating, the pressure differential from inlet plenum to outlet plenum should be 2.2 to 2.5 inches for the M9A1 unit (see Reference 5) and 3.0 to 3.5 inches for the M10A1 unit. If other filter units are in use, design data must be obtained for these. With the blower operating at approximately the correct pressure drop, the building pressure should be about 0.6 inches water. If a built-in draft gage and pressure taps are not provided for the shelter and air locks, the 10-inch inclined-vertical draft gage used for the filters can be used for checking shelter pressurization. Figure 4 shows a typical built-in draft gage arrangement. Copper tubes should be installed to run to the points indicated. The number of valves and length of tubing required for a particular installation depends on the number of rooms to be tested. The tube going to the outside from valve 1 should be terminated at a point completely sheltered from the wind. Before making pressurization tests, set the draft gage at "zero" point and adjust air lock flow regulators to approximate operating positions.

Start the collective protector system blower and set the damper to give the proper filter pressure drop established in paragraph a. above. Check the shelter pressure by opening valve 3. (Note, valves 1 and 2 are always kept open.) The pressure should be 0.5 to 0.6 inches of water. If a relatively higher or lower reading is obtained, adjust the air lock exhaust regulators and anti-backdraft valves and any additional regulators that may be provided to achieve this pressure in the main shelter area. Then readjust the blower damper to obtain the proper pressure drop across the filters and check the air flow cfm rate as described in the next paragraph. If the proper pressure drop cannot be obtained by opening or closing the damper, the check of the air flow cfm rate will give an indication of the source of trouble. However, the air flow cfm check should be made even if a normal pressure drop has been obtained across the filter unit.

To check the air flow cfm rate, an anemometer or pitot tube, as listed in the test equipment list at the end of the report, can be used. The pitot tube is most advantageous if a straight run of metal-ducting is available near the collective protector discharge. The

anemometer is best used where all the air to the shelter is being discharged at a few openings that are readily accessible.

To use the pitot tube, drill a small hole a little larger than the pitot tube near the downstream end of the straight duct, preferably about 7 diameters downstream from the last elbow before the straight run. The draft gage should be connected across the side arm and end of the pitot tube. The pitot tube must point directly upstream when the reading is taken. Figure 5 diagrams the proper location and draft gage connections. A carpenter's square is useful in keeping the tube perpendicular. The reading on the draft gage will be in inches of water. To convert this reading to the actual air flow in cfm, it is necessary to compute the air velocity from the gage reading. Using a slide rule or mathematics table, find the square root of the draft gage reading. For example, if the reading is 0.09, the square root is 0.3 (0.3×0.3 equal 0.09). Multiply the square root by 3250 to get the air velocity. (For example, 3250×0.3 equals 975 fpm.) Then compute the duct cross-sectional area in square feet. Multiply the air velocity times the duct cross-sectional area to obtain the air flow in cfm. Readings should be taken preferably when the air temperature is between 60 and 80 F. The duct velocity will usually be in the range of 600-1000 fpm.

To determine flow with the anemometer, it is necessary to use it to measure air velocity in feet per minute at each discharge opening in the ventilation system. For this purpose, remove any distributing grills, take several readings at each opening and then calculate the average velocity for each opening. Measure the size of each opening and calculate the cross-sectioned area in square feet. The fpm velocity times the square feet of discharge area gives the cfm for each opening. The sum of cfm for all openings gives the total filtered air output. This should total the design capacity.

If the air flow determined by the anemometer or pitot tube is lower than the design capacity, open the damper further and recheck. If proper flow cannot be obtained with the damper wide open and with the total pressure drop across the filters at about 4.5 inches, a new particulate filter section is needed. If excessive air flow is found to occur at the design pressure drop for

the filter unit, the particulate or gas filter may be loose or damaged. The pressure drop across the particulate filter generally will be at least 1.0 inch. The gas filter pressure drop should be at least 1.25 inches.

b. Air Lock Pressurization. After the main air flow has been established at the design rate with the main shelter at about 0.6 inch of pressure, the pressure levels through the air locks should be checked with the air lock doors closed. Using a manifold arrangement similar to that shown in Figure 4, the pressure readings can be made in succession from the main shelter area to the outer air lock. The level at the shower room should be 0.1 inch lower than the main shelter area, the inner air lock 0.2 inch lower than main shelter area and the outer air lock, 0.3 inch lower than the main shelter area. Typical readings would thus be 0.6, 0.5, 0.4 and 0.3. If the main shelter reading is only 0.5, the readings would be 0.4 at the shower, 0.3 at the inner air lock and 0.2 at the outer air lock. To achieve these levels, it may be necessary to adjust the air regulator in the doors between air lock compartments. Successive adjustments may be necessary to achieve the 0.1 differentials between compartments. When the approximate values are obtained, the air flow through one of the regulators in a compartment should be checked with an anemometer. Total air flow through the regulator should be about 350-400 cfm (average anemometer reading multiplied by the regulator opening size in square feet). Continue adjusting regulator until air flow is about 350 cfm to 400 cfm when pressure differentials are 0.1 inch from lock to lock.

If it proves to be impossible to obtain a high enough pressure in the main shelter even with regulators almost closed, it is likely that leaks or improper openings exist in the shelter. Check for open cracks, drains, vents, conduits, antenna ports, and unauthorized changes in the shelter structure. Caulk, tape, or board over any such openings and recheck for proper pressure levels with the filtered air supply being delivered at proper rate and pressure.

7. Filter efficiency

It is generally impractical to test the efficiency of the particulate filters without special equipment and trained personnel. However, some stations with extensive industrial hygiene facilities may be able to make a field check for leakage. If millipore filter air sampling units are available, a check can be made with a methylene blue aerosol. Equipment required includes two millipore filter air samplers, a laboratory microscope with oil immersion lens, a vacuum pump, and a small paint sprayer. The air samplers with 0.4 or 0.8 micron pore size millipore filters should be connected to the manometer taps to draw air from upstream and downstream of the filter unit. About a pint of 2 per cent solution of methylene blue in water is put into the paint sprayer and the sprayer adjusted to produce a very fine mist. This mist should be discharged for about 10 minutes near the ventilation air inlet while the blower and both air samplers are running. A small piece of each millipore filter is then placed on a microscope slide and rendered transparent with immersion oil. Each piece is observed for very small particles at about 900 magnification. There should be very few of the blue particles on the downstream sample and a large number on the upstream sample. The ratio of number of particles should be higher than 5000 to 1. If it is not, a special check should be requested.

8. Emergency air control systems

- a. Oxygen bottle weight
- b. Oxygen bottle regulator
- c. Hand blower operation
- d. CO₂ canister weight and condition
- e. O₂-CO₂ test kit - renew chemicals

C. Air Cooling. (Check and run monthly unless only well water is being used. An air conditioning mechanic should do this work.)

1. Compressor
2. Expansion valve and controls
3. Condenser air or water flow
4. Cooling coil
5. Cooling water, piping, valves, drain or pump
6. Cooling water storage
7. Ice unit
8. Flexible connections
9. Leakage and corrosion

D. G-Alarm

1. Check according to manual
2. Collective protection by-pass automatic operation

VII. WATER SUPPLY

The water supply system inspection includes:

A. Storage Tanks

1. Bacteriological and taste test
2. Drain, flush, and refill (6 months)
3. Valves and lines
4. Hand pump
5. Flexible connections

B. Well and Pumps

1. Water table
2. Capacity (run at design capacity for 1 hour)
3. Control system and switches
4. Valve operation

C. Decontamination Showers

1. Water heater
2. Shower valves and drains
3. Hand pumps

VIII. SANITARY SYSTEMS

The sanitary system inspection covers:

A. Trash Collection Containers

B. Sewage Disposal

1. Toilets
2. Chemicals or bags
3. Drain or check valves
4. Cleanliness and maintenance
5. Sumps and floats
6. Pumps
7. Vent system
8. Flexible connections

IX. COMMUNICATIONS

The communication system inspection covers:

A. Telephones

1. Circuits
2. Switches

B. Radio

1. Antennas and connections
2. Corrosion
3. Battery replacement (yearly or oftener)
4. Operate on all bands

C. Interior PA System

1. Batteries
2. Operate for one-quarter hour or more from line power supply

D. R.I. Shielding

1. Continuity
2. Corrosion
3. Ground

X. SPECIAL SUPPLIES

The special supplies to be inspected include:

A. Decontamination

1. Gas masks
2. CW test kit
3. Decontamination chemicals
 - a. Bleach
 - b. Formaldehyde
 - c. DANC
 - d. DS-2
4. Ropes and signs
5. Clothing, gloves and booties

B. Radiation Monitoring

1. Remote detectors (replace batteries)
2. Personnel monitor (replace batteries)
3. Dosimeters

C. Internal Fire Protection

1. Water extinguisher
2. Sand buckets
3. CO₂ bottle weights

D. Operation Instructions

1. Detailed shelter organization instructions should be stored in the shelter
2. Detailed mechanical operation manual for all equipment.

E. Emergency Tools

1. Shovels
2. Sledge
3. Pick
4. Axe
5. Tool kits for engine-generator and other mechanical equipment
6. Weapons
7. Epoxy patching kit
8. Lanterns
9. Rope

XI. SUBSISTENCE SUPPLIES

The subsistence supplies to be inspected include:

A. Food

1. Quantity
2. Condition
3. Dishes

B. Medical and First-Aid Supplies

C. Blankets and Towels

REFERENCES

1. Bureau of Yards and Docks. NAVDOCKS P-81, Personnel Shelters and Protective Construction. Washington, D. C., September 1961.
2. U. S. Army, Corps of Engineers. Manual EM1110-345-461, Collective Protection Against Chemical, Biological, and Radiological Warfare Agents. Washington, D. C., 1 October 1958.
3. U. S. Army Chemical Corps Engineering Command. ENCR No. 30, Protection of Structures from Chemical, Biological, and Radiological Contamination. Army Chemical Center, Maryland, June 1959.
4. Department of Defense. Protective Construction Review Guide, Volume I. Office of the Assistant Secretary of Defense. (Installation and Logistics). Washington, D. C., June 1961.
5. Bureau of Yards and Docks. NAVDOCKS P-92, Gas-Particulate Filter Units M9A1 and M10A1. Washington, D. C., May 1962.
6. Francy, LCDR W. J., "A New Blast Closure Device for Personnel Protective Shelters," Technical Digest, Volume 100 (October-November 1959), pp 3-7, Bureau of Yards and Docks, Washington, D. C.
7. Champeny, J. C., et al. "Nuclear Bomb Alarm Systems," Electronics, 8 May 1959.
8. Department of the Army, Signal Corps. Instruction Manual, Radiation Detection and Alarm System, AN/FJW-1(V), 22 November 1958.

APPENDIX
TEST EQUIPMENT LIST

1. A-C clamp ammeter (Weston, Amprobe)
2. General purpose electrical testor
3. Fuel pump for pumping fuel storage
4. Water pump for pumping water storage
5. Air conditioning mechanic's tool kit
6. Electrician's tool kit
7. Engine mechanic's tool kit
8. Instrument technician's tool kit
9. Draft gage manometer - 0-6 inches (Ellison, Meriam or similar brand)
10. Rubber tubing
11. Sampling taps
12. Anemometer (Biram type) - 4 inch diameter - with jeweled bearings
13. Electronic photoflash unit
14. Pitot tube (Ellison)

SUGGESTED TEST PERSONNEL

1. Mechanical Engineer
2. Instrument Technician
3. Air-Conditioning Mechanic
4. Diesel-Electric Mechanic
5. Civil Engineer
6. Utilities Foreman

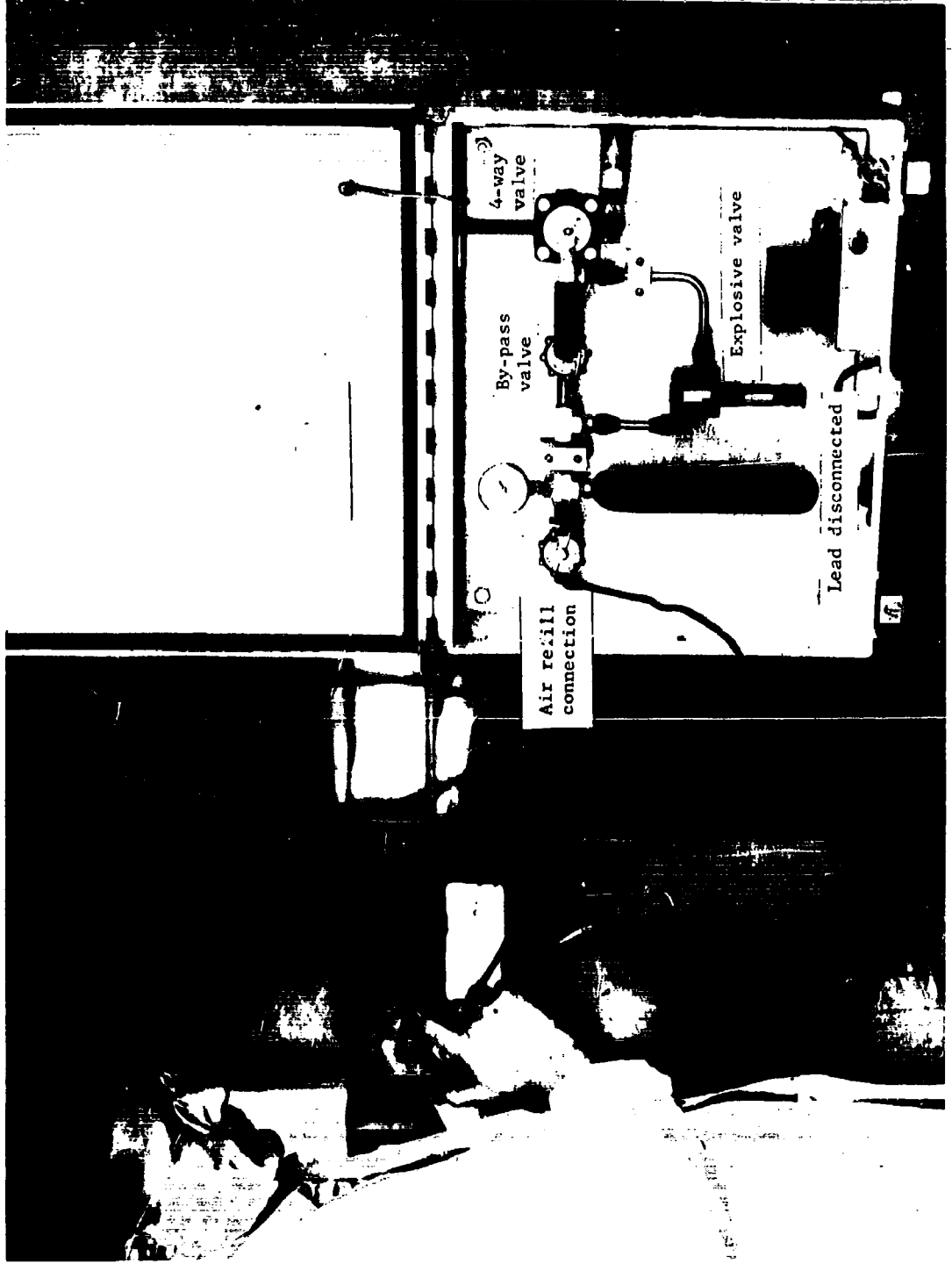

Figure 1. AMF blast closure control panel.

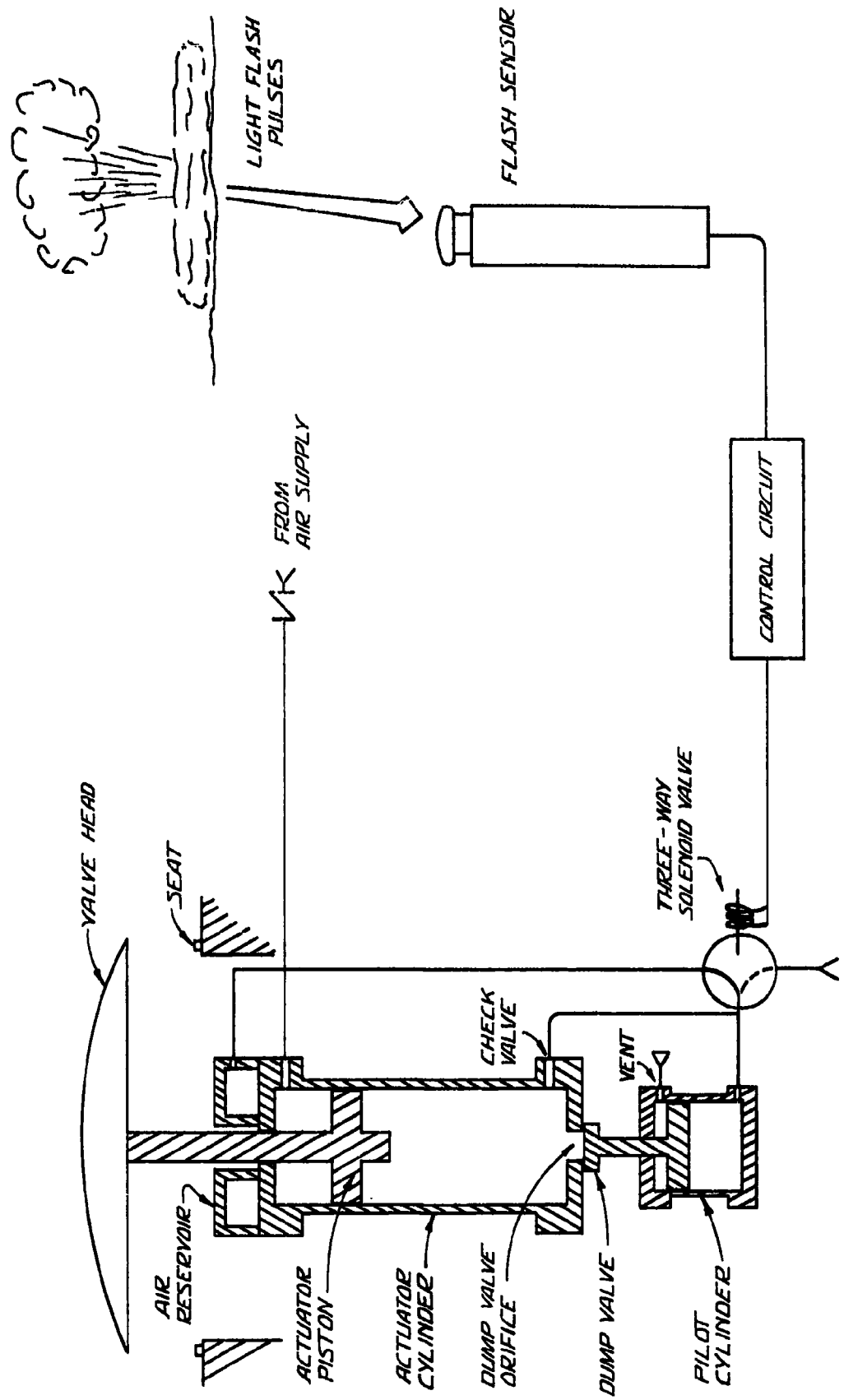

Figure 2. Operation of Mosler blast closure valve.

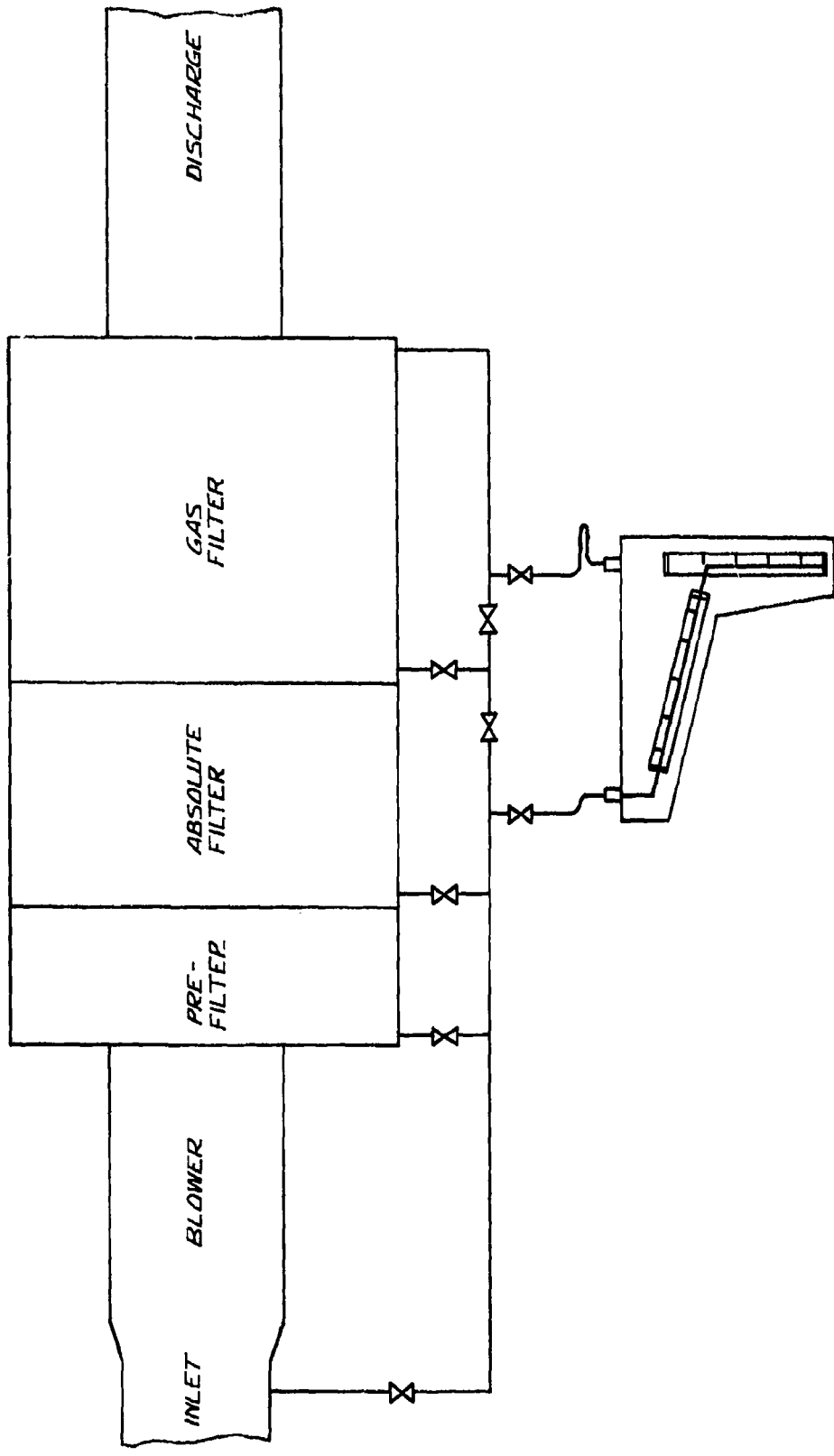

Figure 3. Manometer installation for filter system.

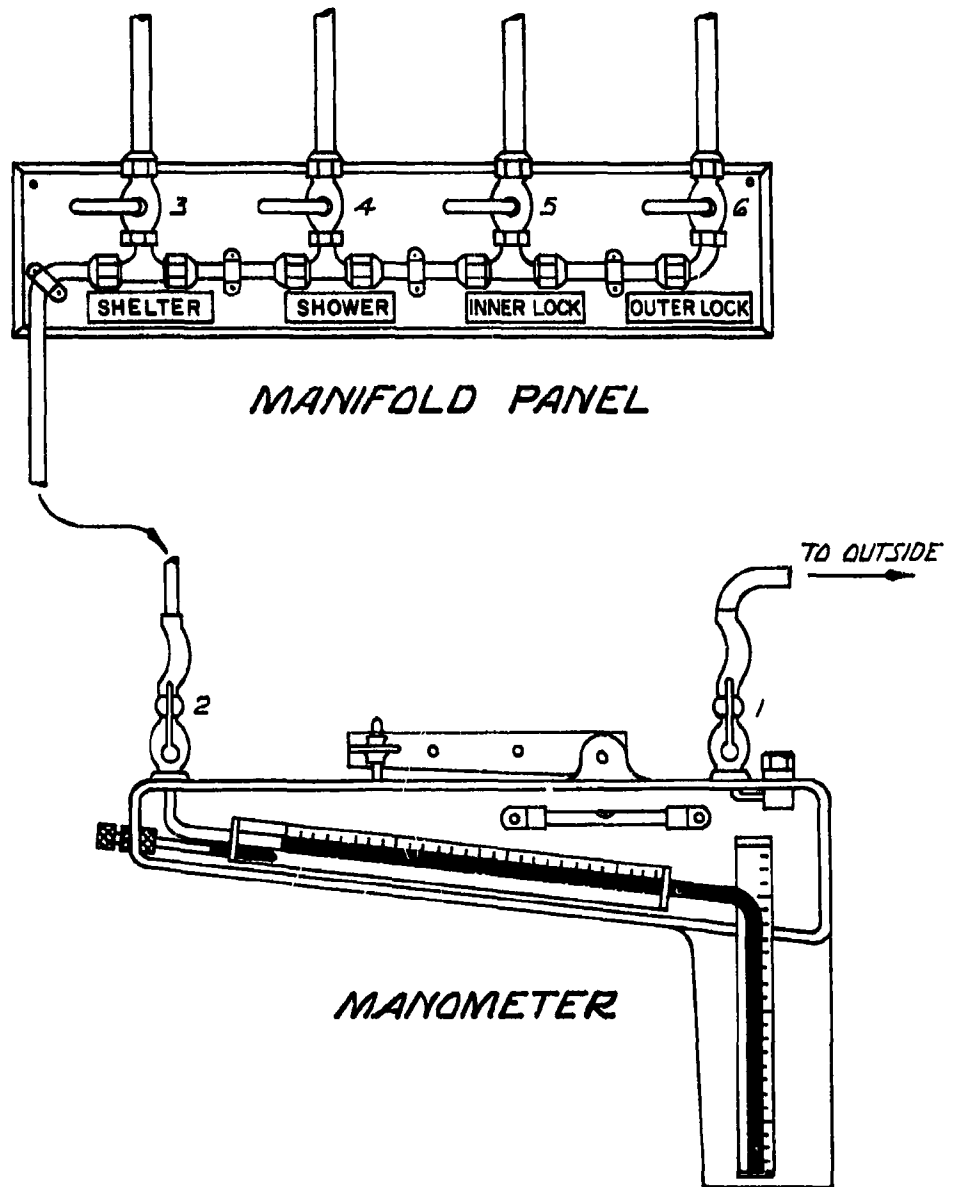

Figure 4. Manometer and manifold arrangement for shelter pressure tests.

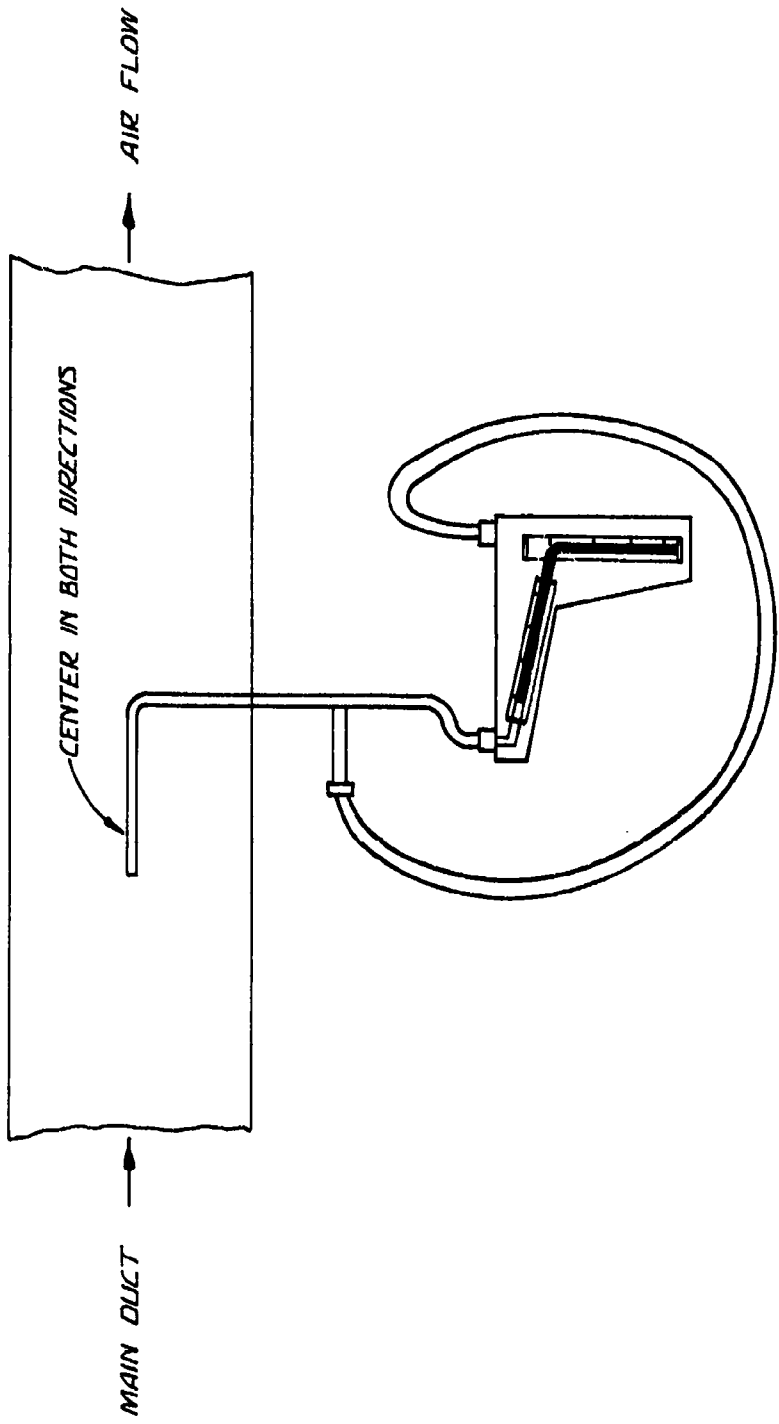

Figure 5. Pitot tube installation.

Unclassified

Security Classification

DOCUMENT CONTROL DATA - R&D

(Security classification of title, body of abstract and indexing annotation must be entered when the overall report is classified)

1. ORIGINATING ACTIVITY (Corporate author) U. S. Naval Civil Engineering Laboratory Port Hueneme, California 93041		2a. REPORT SECURITY CLASSIFICATION Unclassified	
		2b. GROUP	
3. REPORT TITLE Test Procedures for Protective Shelters			
4. DESCRIPTIVE NOTES (Type of report and inclusive dates) Final - March 1964 to March 1965			
5. AUTHOR(S) (Last name, first name, initial) Nehlsen, William R.			
6. REPORT DATE 15 March 1965		7a. TOTAL NO. OF PAGES 22	7b. NO. OF REFS 8
8a. CONTRACT OR GRANT NO.		9a. ORIGINATOR'S REPORT NUMBER(S)	
b. PROJECT NO. Y-F011-05-03-401(g)		TN-588 (Revised)	
c.		9b. OTHER REPORT NO(S) (Any other numbers that may be assigned this report)	
d.		NA	
10. AVAILABILITY/LIMITATION NOTICES Qualified requesters may obtain copies of this report from DDC.			
11. SUPPLEMENTARY NOTES		12. SPONSORING MILITARY ACTIVITY Bureau of Yards and Docks Navy Department Washington, D. C. 20390	
13. ABSTRACT <p>Protective shelters must be maintained in good condition to function properly when required. This report lists equipment that should be checked annually or more often to ensure that shelters can operate as designed.</p> <p>Procedures for testing several special items of shelter equipment are also given.</p>			

14. KEY WORDS	LINK A		LINK B		LINK C	
	ROLE	WT	ROLE	WT	ROLE	WT
Procedures	8					
Maintenance	4,8					
Testing	4,8					
Equipment	9					
Shelters	4					

INSTRUCTIONS

1. ORIGINATING ACTIVITY: Enter the name and address of the contractor, subcontractor, grantee, Department of Defense activity or other organization (*corporate author*) issuing the report.

2a. REPORT SECURITY CLASSIFICATION: Enter the overall security classification of the report. Indicate whether "Restricted Data" is included. Marking is to be in accordance with appropriate security regulations.

2b. GROUP: Automatic downgrading is specified in DoD Directive 5200.10 and Armed Forces Industrial Manual. Enter the group number. Also, when applicable, show that optional markings have been used for Group 3 and Group 4 as authorized.

3. REPORT TITLE: Enter the complete report title in all capital letters. Titles in all cases should be unclassified. If a meaningful title cannot be selected without classification, show title classification in all capitals in parenthesis immediately following the title.

4. DESCRIPTIVE NOTES: If appropriate, enter the type of report, e.g., interim, progress, summary, annual, or final. Give the inclusive dates when a specific reporting period is covered.

5. AUTHOR(S): Enter the name(s) of author(s) as shown on or in the report. Enter last name, first name, middle initial. If military, show rank and branch of service. The name of the principal author is an absolute minimum requirement.

6. REPORT DATE: Enter the date of the report as day, month, year; or month, year. If more than one date appears on the report, use date of publication.

7a. TOTAL NUMBER OF PAGES: The total page count should follow normal pagination procedures, i.e., enter the number of pages containing information.

7b. NUMBER OF REFERENCES: Enter the total number of references cited in the report.

8a. CONTRACT OR GRANT NUMBER: If appropriate, enter the applicable number of the contract or grant under which the report was written.

8b, 8c, & 8d. PROJECT NUMBER: Enter the appropriate military department identification, such as project number, subproject number, system numbers, task number, etc.

9a. ORIGINATOR'S REPORT NUMBER(S): Enter the official report number by which the document will be identified and controlled by the originating activity. This number must be unique to this report.

9b. OTHER REPORT NUMBER(S): If the report has been assigned any other report numbers (*either by the originator or by the sponsor*), also enter this number(s).

10. AVAILABILITY/LIMITATION NOTICES: Enter any limitations on further dissemination of the report, other than those

imposed by security classification, using standard statements such as:

- (1) "Qualified requesters may obtain copies of this report from DDC."
- (2) "Foreign announcement and dissemination of this report by DDC is not authorized."
- (3) "U. S. Government agencies may obtain copies of this report directly from DDC. Other qualified DDC users shall request through _____."
- (4) "U. S. military agencies may obtain copies of this report directly from DDC. Other qualified users shall request through _____."
- (5) "All distribution of this report is controlled. Qualified DDC users shall request through _____."

If the report has been furnished to the Office of Technical Services, Department of Commerce, for sale to the public, indicate this fact and enter the price, if known.

11. SUPPLEMENTARY NOTES: Use for additional explanatory notes.

12. SPONSORING MILITARY ACTIVITY: Enter the name of the departmental project office or laboratory sponsoring (*paying for*) the research and development. Include address.

13. ABSTRACT: Enter an abstract giving a brief and factual summary of the document indicative of the report, even though it may also appear elsewhere in the body of the technical report. If additional space is required, a continuation sheet shall be attached.

It is highly desirable that the abstract of classified reports be unclassified. Each paragraph of the abstract shall end with an indication of the military security classification of the information in the paragraph, represented as (TS), (S), (C), or (U).

There is no limitation on the length of the abstract. However, the suggested length is from 150 to 225 words.

14. KEY WORDS: Key words are technically meaningful terms or short phrases that characterize a report and may be used as index entries for cataloging the report. Key words must be selected so that no security classification is required. Identifiers, such as equipment model designation, trade name, military project code name, geographic location, may be used as key words but will be followed by an indication of technical content. The assignment of links, roles, and weights is optional.