

UNCLASSIFIED

AD NUMBER
AD453253
NEW LIMITATION CHANGE
TO Approved for public release, distribution unlimited
FROM Distribution authorized to U.S. Gov't. agencies and their contractors; Foreign Government Information; APR 1964. Other requests shall be referred to British Embassy, 3100 Massachusetts Avenue, NW, Washington, DC 20008.
AUTHORITY
DSTL, DSIR 23/32303, 2 Jul 2008

THIS PAGE IS UNCLASSIFIED

UNCLASSIFIED

AD 4 5 3 2 5 3

DEFENSE DOCUMENTATION CENTER

FOR

SCIENTIFIC AND TECHNICAL INFORMATION

CAMERON STATION ALEXANDRIA, VIRGINIA



UNCLASSIFIED

NOTICE: When government or other drawings, specifications or other data are used for any purpose other than in connection with a definitely related government procurement operation, the U. S. Government thereby incurs no responsibility, nor any obligation whatsoever; and the fact that the Government may have formulated, furnished, or in any way supplied the said drawings, specifications, or other data is not to be regarded by implication or otherwise as in any manner licensing the holder or any other person or corporation, or conveying any rights or permission to manufacture, use or sell any patented invention that may in any way be related thereto.

U.D.C. No. 538.3 : 532.5 : 537.56 : 06.076(71+73) : 061.3

Technical Note No. Aero 2984

August 1964

ROYAL AIRCRAFT ESTABLISHMENT

- NOTES ON: (1) THE 5TH SYMPOSIUM ON ENGINEERING ASPECTS OF  
MAGNETOHYDRODYNAMICS  
(2) A C.A.A.R.C. MEETING ON LABORATORY STUDIES  
OF THERMALLY IONISED GASES

APRIL 1964

Edited by E. G. Broadbent

---

SUMMARY

This paper is a collection of Notes on the two meetings mentioned in the title which were held respectively at The Massachusetts Institute of Technology on the 1st and 2nd April 1964, and in Ottawa and Toronto, on the 6th, 7th and 8th April, 1964, and were attended by three representatives of the United Kingdom under the sponsorship of the Ministry of Aviation, namely;

D. L. Schultz, Oxford University  
J. A. Shercliff, Cambridge University  
E. G. Broadbent, Aerodynamics Department, R.A.E.

The paper is based on notes taken by these three individuals together with a pre-print of the proceedings of the Magnetohydrodynamics Symposium and one or two papers that were given out by individuals during the C.A.A.R.C. meeting.

One of the main subjects of the Magnetohydrodynamics Meeting was that of Power Generation in which considerable progress has been made in the study of generator operation at supersonic speeds including shock effects and in experiments with geometries of Hall type generators. A number of papers were given on accelerators and several more on related topics in experimental physics. There were one or two papers specifically on seeding problems and others on hypersonic flow round blunt bodies.

With regard to the C.A.A.R.C. meeting the present paper is mainly devoted to a summary of the work being carried out in Canada. The conclusions of the meeting are also reported.

---

CONTENTS

	<u>Page</u>
INTRODUCTION	7
PART I	9
1 INTRODUCTION	9
2 MAGNETOHYDRODYNAMIC POWER GENERATORS	9
2.1 Detailed theoretical and experimental study on a large magnetohydrodynamic generator J. F. Louis, G. Gal and P. R. Blackburn of the Avco-Everett Research Laboratory	11
2.2 Generation of short duration pulses in linear magnetohydrodynamic generators H. S. Jones Jnr., C. N. McKinnon and V. H. Blackman of Magnetohydrodynamic Research	12
2.3 Experimental studies of strong Hall effects and $V \times B$ induced ionisation J. Klepeis and R. J. Rosa of the Avco-Everett Research Laboratory	13
2.4 Impurity effects on the ionisation rate in Xenon shock waves B. Zauderer of the General Electric Company, Space Science Laboratory	14
2.5 Theoretical performance of magnetohydrodynamic generators with various electrode geometries G. W. Sutton of General Electric Space Science Laboratory	15
2.6 Small Rankine cycle magnetohydrodynamic systems for space power R. E. Voshall and W. S. Emerich of the Westinghouse Research and Development Centre	15
2.7 Applicability of thermo acoustic phenomena to magnetohydrodynamic conversion systems R. L. Carter, K. T. Feldman Jnr. and C. N. McKinnon of the University of Missouri at Columbia	15
2.8 Verification of the presence of magnetically induced non-equilibrium ionisation in a closed loop magnetoplasmadynamic experiment M. E. Talaat and W. B. Bienert of the Martin Company, Nuclear Division	16

CONTENTS (Cont'd)

	<u>Page</u>
2.9 Magnetohydrodynamic power generation with liquid metals G. A. Brown, W. D. Jackson, K. S. Lee and M. H. Reid	16
2.10 Separated liquid driven vortex magnetohydrodynamic generator C. H. Marston of General Electric Company	16
2.11 Friction factor measurements in liquid metal magnetohydrodynamic channel flows W. D. Jackson and J. R. Ellis	17
2.12 On the performance of electrogasdynamic generators M. C. Gourdine, E. Barreto and M. P. Khan of the Curtiss Wright Corporation	17
3 MAGNETOHYDRODYNAMIC ACCELERATORS	17
3.1 Optimisation of magnetohydrodynamic crossed field accelerators and generators L. E. Ring of the Propulsion Wind Tunnel Facility Aro Inc.	17
3.2 Design and operation of open cycle Hall current neutralised magnetohydrodynamic accelerators and generators with diagonal conducting strip walls J. B. Dix of the University of Tennessee Space Institute and Aro Inc.	18
3.3 A pulse line energy source for plasma accelerators B. R. Hayworth, T. J. Gooding and A. V. Larson of Space Science Laboratory General Dynamics	18
3.4 Experimental studies of oscillations and accompanying anomalous electron diffusion occurring in d.c. low density Hall type crossed field plasma accelerators G. S. Janes and J. Dotson of Avco-Everett Research Laboratory	19
3.5 Study of instabilities and transition to turbulence in a linear Hall accelerator R. V. Hess, J. Burlock, B. Sidney and P. Rockmann of Langley Research Center N.A.S.A.	20
3.6 Experiments on a quasi-steady $J \times B$ accelerator R. L. Lennard and J. A. Fay of the Massachusetts Institute of Technology	20

CONTENTS (Cont'd)

	<u>Page</u>
3.7 Characteristics of a pulsed plasma accelerator T. Donner and W. McKilroy of the Republic Aviation Corporation	20
3.8 Experimental results of a travelling magnetic wave plasma engine R. E. Jones and R. W. Palmer of the N.A.S.A. St. Louis	21
3.9 Status report on the design and test experience of a pilot M.H.D. accelerator for wind tunnel application A. K. Windmueller and L. E. Rittenhouse of Aro Inc.	21
3.10 Optimum design of M.H.D. accelerators R. R. Gold, H. Mirels and J. F. Mullen of the Aro Space Corporation	21
4 BASIC PHYSICS	21
4.1 The conceptual design of an inductive energy storage system using ignitron switching E. D. Symon and G. Broner	21
4.2 Electrical resistance and sheath potential of a cold electrode in a shock tube with an applied magnetic field D. S. Wilson and D. L. Turcotte of Cornell University	22
4.3 Radiant energy loss from a cesium-argon plasma to an infinite plane parallel enclosure M. Lutz of the Avco-Everett Research Laboratory	22
4.4 The influence of the Ramsauer effect on non-equilibrium electron temperatures C. H. Kruger and J. R. Viegas of Stamford University	23
4.5 Experimental investigation of non-equilibrium electrical conductivity in mercury vapour D. H. Polk of United Aircraft Research Laboratories	23
4.6 Diffusion anomalies in quiescent magneto plasmas K. C. Rogers, P. G. Stern and H. Huger of the Stevens Institute of Technology	23
4.7 Interferometric measurements (Michelson) of rapid phase changes in the visible and near infra-red using a laser light source R. G. Buser and J. J. Kainz of Fort Monmouth	24

CONTENES (Cont'd)

	<u>Page</u>
4.8 Current sheath dynamics and magneto sonic oscillations in magneto plasmas O. M. Friedrich Jnr. and A. A. Dougal of the University of Texas	24
5 SEEDING PROBLEMS	24
5.1 Seed reactions in M.H.D. power generation D. Q. Hoover, F. J. Kalano, W. T. Lindsay and S. M. DeCorso of Westinghouse	24
5.2 A method of seed recovery in coal fired M.H.D. power plants F. Howes and L. Keefe of the Avco-Everett Research Laboratory	24
6 THEORETICAL MAGNETO GAS DYNAMICS	25
6.1 The magneto gas dynamic viscous shock layer in hypersonic flow S-Y Chen of Boeing	25
6.2 Hypersonic magnetohydrodynamics with or without a blunt body R. H. Levy, P. J. Gierasch and D. B. Henderson of Avco-Everett Research Laboratory	25
6.3 On a general variational principle in magneto fluid dynamics R. Balescu of Belgium	26
7 VISIT TO THE LARGE AVCO GENERATOR AT HAVERHILL (3RD APRIL)	26
PART II THE C.A.A.R.C. SYMPOSIUM ON LABORATORY STUDIES OF THERMALLY IONISED GASES HELD ON 6TH, 7TH, AND 8TH APRIL	28
1 INTRODUCTION	28
2 MECHANICAL ENGINEERING DIVISION, N.R.C.	29
2.1 Plasma jet experiment	29
2.2 High velocity shock tube	29
2.3 Theta pinch in argon	29
2.4 Seeded shock tube experiments	30
3 THE PURE PHYSICS DIVISION, N.R.C.	30
4 THE MECHANICAL ENGINEERING DEPARTMENT, THE UNIVERSITY OF TORONTO	31



CONTENTS (Cont'd)

	<u>Page</u>
5 THE INSTITUTE FOR AEROSPACE STUDIES, THE UNIVERSITY OF TORONTO	31
6 THE UNIVERSITY OF BRITISH COLUMBIA	32
7 THE UNIVERSITY OF WESTERN ONTARIO	33
8 MCGILL UNIVERSITY	33
9 THE R.C.A. VICTOR COMPANY LIMITED	33
10 AXFORD'S WORK AT CORNELL UNIVERSITY	34
11 GENERAL DISCUSSION AND CONCLUSIONS	35
ADVANCE DISTRIBUTION LIST	37
ILLUSTRATIONS - Figs. 1-8	-
DETACHABLE ABSTRACT CARDS	-

ILLUSTRATIONS

	<u>Fig.</u>
Simple channel-type M.H.D. generators	
(a) continuous electrodes	
(b) segmented electrodes	1
Various types of Hall current generator	
(a) channel type with segmented electrodes	
(b) co-axial Hall generator geometry	
(c) disk Hall generator geometry	2
Comparison of seeded and non-seeded shaped charges in 1 inch by 1 inch explosion driven M.H.D. generator (M.H.D. Research Inc.)	3
The x-t diagram for the shock tube and accelerator (M.I.T.)	4
Shock tube and associated circuitry (Cornell University)	5
Calculated streamlines for the shocked flow past a magnetic dipole (AVCO Everett)	6
Compression tube and shock tube details (N.R.C.)	7
Scattering of light from electrons in a plasma: experimental arrangement (N.R.C.)	8

### INTRODUCTION

The present paper is concerned with the following two meetings:

- (1) The 5th Symposium on the Engineering Aspects of Magnetohydrodynamics held at the Massachusetts Institute of Technology, 1st and 2nd April, 1964.
- (2) A Symposium on Laboratory Studies of Thermally Ionised Gases held by the Commonwealth Advisory Aeronautical Research Council in Ottawa (with a visit to Toronto) on 6th, 7th and 8th April, 1964.

The United Kingdom representation consisted of:

- D. G. Froot, R.A.R.D.E. (The C.A.A.R.C. meeting only)
- M. McChesney, University of Liverpool
- D. L. Schultz, Oxford University
- J. A. Shercliff, Cambridge University (recently appointed to the Chair of Engineering Warwick University)
- E. G. Broadbent, Aerodynamics Department, R.A.E.

Of these five, Schultz, Shercliff and Broadbent were sponsored by the Ministry of Aviation and the present paper is based on their notes together with pre-prints that were made available. A pre-print of the proceedings of the first meeting was given out upon registration and contained the full text of the ten 20-minute presentations together with summaries of the shorter papers. The C.A.A.R.C. meeting was of course much more informal being a round table discussion aided by a blackboard and a few slides together with visits to various convenient laboratories, and no formal pre-prints were available although one or two papers were exchanged privately.

Since the present paper covers these two rather different meetings it has been divided into two parts, Part I dealing with the Magnetohydrodynamics Meeting at the Massachusetts Institute of Technology and Part II dealing with the C.A.A.R.C. Meeting in Canada. The first meeting emphasised the great energy with which magnetohydrodynamic generators and accelerators are being developed in the United States. Much of the work is going on at Avco but Westinghouse and General Electric also contributed several papers. However, Avco dominates the American M.H.D. generator scene more than used to be the case; General Electric in particular appear to be cutting their efforts. The latest Avco work in a straightforward  $E \times B$  generator suggests that it is advantageous to run the generator at low supersonic Mach numbers instead of subsonic Mach numbers as was originally suggested and even the presence of a shock does not seem to impair the performance very seriously. Hall type generators and accelerators are also receiving much attention and at the moment it seems a close decision as to which will eventually be preferred. The reports made on the seeding problem were on the whole optimistic. Many of the detailed papers are of interest either for bright ideas or for useful techniques and on the theoretical side an extensive treatment of hypersonic magnetohydrodynamic flow past a body containing a magnetic di-pole was given.

At the C.A.A.R.C. meeting many exhibits covering a wide range of interests were seen and described and the meeting was wound up by agreeing on a short report. The main tenor of this report, which is given in Section 11 of Part II is that the wide range of subjects lends itself to small progress meetings in the different fields of activity where Commonwealth specialists can get together and discuss mutual problems. This might conveniently be done following International meetings in a particular field. Quite apart from the value of seeing the work going on in Canada, the United Kingdom Representatives found the meetings very refreshing in their informality, as well as being technically very useful. The visits and descriptions too made it very evident that much of the work going on in Canada is of a very high standard.

---

PART I

THE 5TH SYMPOSIUM ON THE ENGINEERING ASPECTS OF MAGNETOHYDRODYNAMICS  
HELD AT THE MASSACHUSETTS INSTITUTE OF TECHNOLOGY  
ON 1ST AND 2ND APRIL, 1964

1 INTRODUCTION

The Symposium was held in the Kresge Auditorium which is a magnificent lecture theatre with very good acoustics, lighting and ventilation. In fact nobody was observed to be asleep during any of the 35 papers that were presented during the two days. A few of the papers were allotted twenty minutes for presentation, ten minutes for discussion, and these papers are printed almost in full in the proceedings of the Symposium. The remainder of the papers were intended to be reports of current progress and were allotted only half the time of the main papers and for the shorter papers only summaries are given in the proceedings. The purpose of the present paper is to try and summarise the main points made during the Symposium so that any reader who wishes can refer to the main proceedings for further details.

Most of the conference was concerned either with magnetohydrodynamic generators or with magnetohydrodynamic accelerators. Of these the generators start with a relatively hot dense plasma expanded into a high speed flow through a magnetic field and thus make it play the part of a solid conductor in a mechanical generator of electricity. The accelerators accelerate plasma by electromagnetic means for use either as a propulsion device or as a wind tunnel. The same principles are involved in either case but for convenience those papers that related primarily to power generation are dealt with in Section 2 and those that related primarily to plasma acceleration are dealt with in Section 3. This accounts for twenty-two of the papers (twelve on generators and ten on accelerators) and a further eight dealing with relevant problems in experimental physics are discussed in Section 4. Many devices rely on seeding the hot gas with alkali metal vapour in order to obtain adequate electrical conductivity and this introduces problems of its own. Seeding is referred to in many of the papers and is discussed here in Section 5 which refers specifically to two papers that are concerned wholly with the seeding problem. There remain three papers that seem perhaps a little out of place in a Symposium that claims to be on the engineering aspects of magnetohydrodynamics as they are concerned with the theory of magnetohydrodynamic flow. They are discussed in Section 6.

2 MAGNETOHYDRODYNAMIC POWER GENERATORS

Before considering the individual papers it is convenient to give a few notes about magnetohydrodynamic power generation. Fig.1 illustrates the simplest case in which the flow is in the Z direction and the magnetic field is in the X direction. There results an electric field in the Y direction so that if electrodes are placed at the top and bottom of the channel shown in Fig.1 an electric current can be driven from one electrode to the other through an external circuit. In doing so the flow is decelerated and loses some of its

momentum and energy. The principal losses involved in the generator are the Joule heating loss arising both from the conduction current and the Hall current. The Joule heating loss is serious because even with the best seeding possible the conductivity of the plasma at practical temperatures is very low compared with that of a solid conductor. In fact the magnetic Reynolds number ( $R_m = \mu_0 \sigma u$  where these symbols denote respectively the permeability, electrical conductivity, a typical length and the flow velocity and in MKS units have values in a typical generator of the order of  $10^{-6}$ ,  $10^2$ , 1 and  $10^3$ ) is usually small enough for the induced magnetic field to have little effect on the applied field. All the energy expended in Joule heating is not irretrievably lost because it heats up the plasma and can in principle be tapped off again further along the channel. However the electric current generates a decelerating force in the presence of the magnetic field which is balanced by the pressure drop along the channel so that to recover the Joule loss expansion to lower pressures becomes necessary. From a thermodynamic point of view the Joule heating increases the entropy and leads to a less efficient working cycle as well as an increase in the size of the plant.

The Hall current arises from the fact that the electric vector is not parallel with the current vector. This can perhaps best be seen by noting the motion of particles in perpendicular electric and magnetic fields. The path of an ion starting from rest is initially in the direction of the electric field and after describing a half circle around the magnetic field is at rest again when it starts another half circle and thus drifts in the  $E \times B$  direction. The electron drifts in the same direction at the same speed by way of very much smaller semi-circles the other way up. Thus in the absence of collisions there is a bodily shift of the plasma without a flow of electric current. With the conditions of temperature and density that are present in most plasma generators however, the ions would make many collisions before completing a half circle and in fact motion of the type just described is only possible to a significant extent for the electrons so that an electric current (the Hall current) can flow in a direction perpendicular to  $E$  and  $B$ . For a very dense plasma even the electrons would make many collisions before covering the radius of one of their semi-circles (the Larmor radius) and again no Hall current would flow. The critical parameter for determining the magnitude of the Hall current is  $\omega\tau$  where  $\omega$  is the gyro frequency of the electrons and  $\tau$  is their mean collision time. If this parameter is large then the Hall currents can be expected to be strong. They are in any case certain to involve much too great a loss in practice if single electrodes are used for the whole channel. The electrodes can however be segmented to avoid the flow of Hall current and in this case each pair of segments can be treated as the electrodes for a separate external circuit. Unfortunately the electric potential will vary from one pair of electrodes to the next and this leads to considerable complication in the engineering application.

Alternatively it is possible to operate the generator as a Hall current generator. One way of doing this is to use the same type of channel flow as in Fig. 1 with segmented electrodes again but with each pair shorted across so that the electrode segments in effect form a number of complete rings around the channel. Since the electric potential is now uniform around a cross section the Hall effect produces an e.m.f. in the  $Z$  direction which can be turned into useful power simply by connecting the two end electrodes through the external

load. This obviously makes for a much simpler engineering arrangement at the price of some efficiency since there are practical limits to the size of the Hall parameter  $\omega\tau$ . The possibility of severe instability has also been noted with Hall current generators. On the other hand the losses incurred by shorting out the conduction current are not in themselves serious because the short circuit resistance is so very much lower than the resistance of the plasma. The channel type of Hall generator is indicated in Fig.2a but it is also possible to design Hall current generators with cylindrical symmetry such that there is no need to short out the conduction current. Two of these are illustrated in Figs.2b and 2c where in each case the conduction current can flow freely in the  $\theta$  direction.

In both the conduction generator and the Hall generator the power output depends on the same factors according to the most elementary treatment. Provided that perturbations of the imposed magnetic field are small the power delivered per unit area of the electrodes is proportional to the product of the distance between the electrodes, electrical conductivity, and the square of the flow speed and the square of the magnetic field. The two favourable features of high conductivity and high flow speed are to some extent mutually opposed since if the gas is expanded to very high speed the temperature and hence the conductivity fall and the drop in conductivity becomes very rapid below certain values of temperature. This is of course one reason why seeding is so important. Powerful magnetic fields are necessary and any improvement here shows a big increase in power output and as a future possibility superconducting magnets are an obvious attraction. The highest field used in a design study at the conference was a hundred kilo Gauss although it is true that reference to this brought a mild titter from the audience.

On 3rd April it was possible to visit some of the local magnetohydrodynamic laboratories one of which was the Avco Magnetohydrodynamic Generator Facility. On show here was the largest generator that has so far been operated which was designed to deliver an output of about twenty-two megawatts, in order to achieve which some eighteen megawatts are expended in the magnetic field. At the time of the visit, however, the design values of twenty-two megawatts and eighteen megawatts had not been approached in runs. These facts illustrate the need for a large facility in order to obtain reasonable efficiency since the heat loss to the channel wall, the friction loss, the electrode loss and the loss in the field coil increase less rapidly with the size of the generator than does the power output so that generators delivering hundreds of megawatts are envisaged. The generator on show could only be run for a few minutes at a time because the field coils were not fully cooled.

#### Papers Presented

- 2.1 Detailed theoretical and experimental study on a large magnetohydrodynamic generator  
J. F. Louis, G. Gal and P. R. Blackburn of the Avco-Everett Research Laboratory

This paper covered a number of experiments supported by a certain amount of theory. The apparatus is a channel flow generator with electrodes segmented into fifty units. The working fluid consisted of the combustion products

of oxygen and a solution of fifty per cent methylcyclohexane with fifty per cent ethyl alcohol and seeding was provided by potassium hydroxide dissolved in the latter. The magnetic field was thirty-three kilo Gauss and the mass flow was varied from 3 to 6.5 lb/sec. The resulting power output varied in the range fifteen hundred to two hundred kilowatts and the Hall coefficient  $\omega$  varied up to about two. The paper makes the point that moderate supersonic flows, e.g. at a Mach number of 1.4 can be used with advantage since up to this point the increase of speed more than offsets the lower conductivity and the greater frictional loss to the walls. It is possible to design for supersonic flow throughout the channel but if the matching of mass flow, duct geometry and electrical loading is imperfect the flow may decelerate through a shock at some point in the channel. In fact the location of the shock is easier to determine than in pure aerodynamic channel flow because the retarding force is not merely the comparatively weak frictional force at the walls but includes also the powerful Lorenz force. The shocked flow is studied in some detail with particular reference to shock induced separation. The separated region extends for nearly half a meter in a total length of two and a half meters and appears to have a maximum thickness of about half the total channel depth which is 0.3 meters. It is pointed out that separation is more likely to occur over an electrode than over the strongly cooled insulating walls and in fact separation occurred from the cathode. The pressure distribution was calculated in the separated region based on an assumed velocity profile and gave reasonable agreement with experiment. In addition the axial pressure distribution over the whole of the channel allowing for blockage due to boundary layer growth and separation was calculated and gave good agreement with observed values.

The following extract from the conclusions is of interest. "These experiments demonstrated that there is a gain of performance to be derived by establishing a moderately supersonic flow in a magnetohydrodynamic generator. It further showed that for the supersonic flows of interest ( $M$  less than or equal to 1.5) the pressure loss due to a shock in off-design conditions is only slightly detrimental to the performance. .... Finally, it has been found that the electrode losses associated with the presence of a Hall field can seriously hamper the performance of a magnetohydrodynamic generator. Although this loss can be reduced by augmenting the degree of electrode segmentation with increasing values of the Hall field, practical limits to segmentation will exist and these losses will have to be seriously considered." This paper represented the principal discussion of an engineering generator and has been covered here rather fully. It represents quite a landmark because it is the first to show results for the internal fluid mechanics of an M.H.D. generator. The other papers will be discussed more briefly.

## 2.2 Generation of short duration pulses in linear magnetohydrodynamic generators

M. S. Jones Jnr., C. N. McKinnon and V. H. Blackman of Magnetohydrodynamic Research

On this type of generator pulses of power are obtained by generating the working fluid from an explosive. In this case it is much easier to obtain relatively high conductivity and in fact the assumption of low magnetic Reynolds number is no longer automatically satisfied. Typical values quoted in MKS units are  $10^3$  for the conductivity and  $10^4$  for the flow velocity which leads to a

magnetic Reynolds number per meter of the order of 10. Since the relevant length in the apparatus described in this paper was of the order of 0.04 meters, the magnetic Reynolds number was about a half. For large values of the magnetic Reynolds number it is worth noting that the current in the plasma reaches a saturation value and the power output per unit area becomes proportional to the product of the flow speed with the square of the magnetic field and independent of the conductivity.

In the experiments a peak power of 23 megawatts was achieved from a channel one inch by four inches in cross section with electrodes eighteen inches long. The pulse length was sixty microseconds and the transverse magnetic field was 23.5 kilo Gauss. Fifteen grammes of RDX explosive were detonated in this experiment and the front surface of the explosive was seeded with 0.4 grammes of cesium picrate. The conversion efficiency chemical to electrical was one per cent. Among the effects examined was the improvement due to seeding and this is illustrated in Fig.3.

2.3 Experimental studies of strong Hall effects and  $V \times B$  induced ionisation  
J. Klepeis and R. J. Rosa of the Avco-Everett Research Laboratory

In the experimental work described here the working fluid was not a combustion product but was heated argon with a stagnation temperature of two thousand degrees K and seeded with an alkali metal vapour either cesium or potassium. The heater which was basically a graphite heater and the seeding mechanism are described in some detail.

For the generator a channel flow operating in the Hall manner was first used as indicated in Fig.2a. For this type of generator the Hall field  $E_h$  can be made considerably greater than  $uB$  ( $u$  is the flow velocity and  $B$  the magnetic field) if the magnetic field is large enough. In practice this ratio was found to be limited to a value of about 2 at a magnetic field of 10 kilo Gauss although simple theory indicated much higher values. The paper suggests that the reason for the limitation is that of local current concentrations as considered by Kerrebrook in Avco-Everett Research Laboratory Note 416, January 1964. At the presentation however (and not in the printed proceedings) the author showed a curve based on Kerrebrook's theory which underestimated the performance by about as much as the simple theory overestimated it.

On various occasions during the Symposium, reference was made to non-equilibrium ionisation. This is generally regarded as a favourable feature since it leads to higher electrical conductivity than one expects for the working temperature. It was pointed out in the present paper, however, that this non-equilibrium ionisation always first occurs in a layer over the electrodes, and it is this that leads to the current concentrations which in turn lead to a deterioration in performance. Exploitation of non-equilibrium ionisation thus seems to hold little promise with segmented electrode configurations.

To avoid the difficulties of finely segmented electrodes channels using cylindrical symmetry as indicated in Figs.2b and 2c were also tried. A serious difficulty that arises with the co-axial geometry of Fig.2b is that it is very difficult to produce a large radial magnetic field. The disc geometry of Fig.2c however allows a very simple arrangement for the magnetic field but has the



drawback that the flow field is more complicated. However with the disc geometry Hall voltages somewhat greater than four times  $uB$  were obtained.

The following is an extract from the conclusions. "Thus the fact that our data falls close to the eighty per cent uniformity curve suggests that we are getting performance about as good as can be expected at high  $\omega r$ . Although a larger device would probably do better a high  $\omega r$  machine will doubtless always show a larger deviation from ideal performance than a machine at low  $\omega r$ . Nevertheless we feel that these experimental results show that the prospects at high  $\omega r$  are reasonably good for geometries in which the normal current closes within the gas. On the other hand the same geometries may be particularly susceptible to Hall instabilities or wave-making processes..... We do observe a ten to fifteen per cent a.c. component on the output which might become greater in a device of larger scale." The phrase eighty per cent uniformity relates to the idea that a likely, and at the same time, damaging non-uniformity is that of the electrical conductivity varying in the  $u \times B$  direction; this can be expressed as a percentage by means of a suitable parameter, and eighty per cent uniformity is considered to be acceptable. The maximum values of  $\omega r$  plotted are just under twenty. An interesting footnote was provided by Dr. Rosa who read the paper, when he answered a question by saying that he still thought the ideal generator would be an ordinary channel type with segmented electrodes hooked up and operated as a Hall generator.

2.4 Impurity effects on the ionisation rate in Xenon shock waves  
B. Zauderer of the General Electric Company, Space Science Laboratory

In generators non-equilibrium conditions often exist in which the electron temperature is higher than the gas temperature and in these conditions the effect of impurities is important. The experiment used a two inch square Xenon shock tube with a helium driver and a generating section with eighteen pairs of individually short circuited tungsten electrodes flush mounted inside a two inch square alumina channel. A pulsed magnetic field of up to 20 kilo Gauss could be provided with an available test time of 700 microseconds. A shock velocity was chosen in which the delay time before full conductivity was achieved approached the available testing time. These conditions were a shock velocity of 1450 meters/sec, Mach number of 8.2, an initial pressure of nine millimeters of mercury and a temperature behind the shock of 6,500 degrees K. The delay time was 500 microseconds by which time the electrical conductivity had risen to seventy mhos per meter. The object of the experiment was to test the effects of impurities for which oxygen, nitrogen and hydrogen were used in amounts varying between 0.01 mol per cent and 1 mol per cent. The delay time was observed to decrease with increasing impurity concentration from 350 microseconds at 0.01 mol per cent to less than 100 microseconds at 1 mol per cent and at the same time the peak conductivity was increased by a factor between two and three which was almost independent of the type and concentration of impurity. It is inferred that although the diatomic molecules have higher ionisation potentials than Xenon their vibrational states allow a stepwise excitation of ionised Xenon. Similar results were obtained in the presence of the magnetic field. When the paper was presented the lecturer also showed a curve in which helium was the impurity. This was still found to have an appreciable effect in reducing the ionisation time delay although less than that of the diatomic molecules.

2.5 Theoretical performance of magnetohydrodynamic generators with various electrode geometries  
G. W. Sutton of General Electric Space Science Laboratory

This paper reported some calculations based on channel flow in which the following assumptions were made.

- (1) Constant magnetic field.
- (2) Constant flow velocity.
- (3) Constant scalar electrical conductivity.
- (4) Constant gas density.
- (5) Perfect insulators and electrodes.

The position and shape of the electrodes was varied including the effect of fins, i.e. conducting strips mounted perpendicular to the electrodes and parallel to the direction of flow. If these fins were added to otherwise complete electrodes a reduction in overall efficiency was found but greater efficiency could again be recovered at the cost of some loss in power density by cutting away part of the conventional electrode. Since these calculations neglect boundary layer effects however it seems likely that the use of fins will be even less attractive in practice.

2.6 Small Rankine cycle magnetohydrodynamic systems for space power  
R. E. Voshell and W. S. Emmerich of the Westinghouse Research and Development Centre

This paper sketched a possible design for a space power system based on a working fluid of lithium vapour seeded with one per cent of cesium. The heat from a nuclear reactor for example is used in a boiler from which the alkali metal vapour is passed through a photo ionisation unit from which it expands at a constant velocity of 800 meters/second through a channel with an inlet temperature of 1350 degrees K and an outlet temperature of 1140 degrees K. The duct length is 0.7 meters, the output power is 30 kilowatts and the overall cycle efficiency is 7.2 per cent. The conductivity in this design is only 0.3 mho per meter.

2.7 Applicability of thermo acoustic phenomena to magnetohydrodynamic conversion systems  
R. L. Carter, K. T. Feldman Jr. and C. H. McKinnon of the University of Missouri at Columbia

The authors are experimenting with thermo acoustic resonances. For example an open ended tube four inches in diameter and five feet long is divided into two compartments by a nozzle consisting in this case of a number of short thin tubes that fill the main tube about twenty inches from the closed end. The closed end is then heated to about 900 degrees F so that a temperature gradient is maintained across the nozzle and acoustic waves of about  $1\frac{1}{2}$  inches amplitude at sixty cycles/sec are found to develop in the closed part of the tube. These particular

results were quoted at the lecture and not given in the printed summary and are thought to refer to air containing water vapour which was found to increase the effect. If a highly conducting gas is used a.c. power can be extracted from a coil round the axis of the tube in the presence of a radial magnetic field. In the experiment described 100 watts was obtained in this way. An order of efficiency of five per cent was mentioned.

2.8 Verification of the presence of magnetically induced non-equilibrium ionisation in a closed loop magnetoplasdynamic experiment  
M. E. Talaat and W. B. Bienert of the Martin Company, Nuclear Division

A closed cycle magnetoplasdynamic generator operating in the range of 800-870 degrees K was used to investigate the effect of magnetically induced non-equilibrium ionisation. The temperature was so low because the heater had partially failed. The fluid used was helium at a flow rate of six grammes/sec seeded with cesium injected at a rate of 0.23 grammes/second, i.e. a volume seeding of 0.115 per cent. The electrical conductivities observed whenever the magnetic field was applied were over two orders of magnitude higher than those conductivities that could be expected to occur with thermal equilibrium ionisation alone. However the conductivities obtained were still very low being of the order of  $10^{-3}$  mho per meter. The audience was very sceptical that true non-equilibrium ionisation had been achieved at all.

2.9 Magnetohydrodynamic power generation with liquid metals  
G. A. Brown, W. D. Jackson, K. S. Lee and N. H. Reid

This suggests the use of a liquid metal and its vapour in a dual closed cycle. Vapour is raised in a nuclear reactor and enters a condensing ejector which acts as a generator of stagnation pressure. Although the predicted efficiencies turn out lower than those predicted for turbo electric systems in the same power range the magnetohydrodynamic power generator may have some advantages, e.g. no moving parts. A point to note is that the electrical conductivity of the liquid metal is very much higher than in standard gaseous generators being of the order of  $10^6$  mho per meter. This allows high power densities to be achieved.

2.10 Separated liquid driven vortex magnetohydrodynamic generator  
C. H. Marston of General Electric Company

In this configuration the liquid metal is injected tangentially along the inner surface of an annulus from which it slowly works its way outwards through a vortex until it is finally expelled through the porous outer wall of the annulus. A radial magnetic field is applied and the useful current is developed in an axial direction so that the electrode arrangement is very simple. It is suggested that the liquid flow is obtained from a primary vapour flow coming from a boiler into which is injected a liquid core of secondary flow. The two are allowed to mix and a condensation shock develops in the channel. Eventually the flow is fully liquid and is then injected into the generator. Experiments using water as the working fluid are in hand to study the field mechanics of the concept. One difficulty mentioned in relation to this type of generator was that the high conductivity of the fluid means that as soon as it flows out of the magnetic field it will start to short circuit the generator.

2.11 Friction factor measurements in liquid metal magnetohydrodynamic channel flows

W. D. Jackson and J. R. Ellis

In the experiments a closed loop sodium potassium alloy (NaK) flow facility is used. The reason for using the alloy in preference to mercury is because it offers a higher magnetic Reynolds number and a much higher value of the interaction parameter with the magnetic field. The latter is defined as the ratio of the square of the Hartman number to the Reynolds number which amounts to the product of the electrical conductivity with the square of the magnetic field divided by the product of the density with the flow velocity. In fact the gain in using the alloy is a factor of about three for magnetic Reynolds number and about fifty for the interaction parameter. Preliminary experiments have been made with a constant area channel but the extension to other geometries is being studied.

2.12 On the performance of electrogasdynamic generators

M. C. Gourdine, E. Barreto and M.P. Khan of the Curtiss Wright Corporation

This paper does not really come into magnetohydrodynamics since no magnetic field is involved. The idea seems to be to take a flowing stream of gas containing a number of relatively large colloidal particles in the size range  $10^{-7}$  to  $10^{-6}$  meters. These particles are given an electric charge at one of the electrodes in the external circuit and then the energy of the gas stream carries them to the other electrode where the charge is released and flows by way of an electric current through the external load back to the first electrode. It is typical of this type of generator to deliver low current at very high voltage. The paper gives a detailed theoretical analysis including direct closed form integration of the basic set of equations governing the process. In particular a comparison is made between using one broad channel and a number of slender channels. With regard to efficiency a value of forty per cent is mentioned and it is concluded that a little improvement in electro gas dynamics will open a whole new field in power generation techniques. However a serious limitation seemed to be indicated by a Questioner who pointed out that in practice the energy is available at high temperatures which are not compatible with the existence of large colloidal particles. The Lecturer agreed that the process could not be used at high temperature.

3 MAGNETOHYDRODYNAMIC ACCELERATORS

Since accelerators are in principle generators operated in reverse no further introduction is needed.

3.1 Optimisation of magnetohydrodynamic crossed field accelerators and generators

L. E. Ring of the Propulsion Wind Tunnel Facility Aro Inc.

This is a theoretical paper in which performance is optimised with respect to magnetic field, electric field and area distribution around the channel as well as to the inlet and exit conditions. A variational analysis is used and optimisation is by way of minimising the length of the channel. An example is worked out for real air under acceleration from a reservoir pressure of 200

atmospheres to an exit condition of 25,000 ft/second at 240,000 ft altitude. Seeding is provided by 0.25 per cent of potassium by weight and limitations are imposed on the magnetic field and the Hall coefficient being forty kilo Gauss and four respectively. The channel is three metres long and the effect of the limitations is that for rather more than half the length of the channel the magnetic field remains constant at forty kilo Gauss while the Hall coefficient increases from a half up to four and thereafter the Hall coefficient remains constant while the magnetic field falls away to just over ten kilo Gauss. The temperature falls only slightly from 4,000 degrees K to about 3,300 degrees K.

Although the analysis is in principle applicable either to an accelerator or to a generator, the Author points out that there is in one sense more to be gained by optimising an accelerator since the energy applied to the gas will be three or four times the energy contained by the initial gas whereas in a generator only perhaps twenty per cent of the initial gas energy is used in the channel.

3.2 Design and operation of open cycle Hall current neutralised magnetohydrodynamic accelerators and generators with diagonal conducting strip walls

J. B. Dix of the University of Tennessee Space Institute and Aero Inc.

This paper suggests an accelerator design that makes use of the fact that the electric field vector remains parallel to itself throughout most of the channel. It will be perpendicular to the magnetic field vector but set at some angle to the flow velocity owing to Hall effects. If one now imagines a series of closely spaced planes drawn perpendicular to the electric field vector, these planes will intersect the walls of the channel and for any given plane the intersection will be at a constant electric potential. It is suggested that each intersection should be made into a conducting strip of metal and one intersection separated from the next by an insulating strip since the equipotential condition will prevent currents flowing around the metal strips. Quite what the advantages of this scheme are was not clear, the only one mentioned being that the conductors and insulators run entirely round the channel. Under a test comparison with a conventional channel using insulating walls the performance of the two channels was much the same near the design conditions of the diagonal strip channel but this channel's performance fell away at about ten per cent off the design conditions.

3.3 A pulse line energy source for plasma accelerators  
B. R. Hayworth, T. J. Gooding and A. V. Larson of Space Science Laboratory General Dynamics

This paper describes the development of apparatus to give a relatively high capacity with very low inductance for space applications. The written summary quotes a single twenty-two inch diameter toroidal capacitor weighing only a hundred pounds compared with six hundred pounds for a paralleled array, and with a capacity of 22.3 microfarads at ten kilovolts. The inductance was of the order of  $10^{-9}$  henry. The impedance of the line was about seventeen milliohms, the pulse time was 0.8 microseconds and the unit delivered 200,000 amps to the coaxial gun at six millivolts. In the verbal presentation it was stated that they have since built six more lines with different geometries

and have succeeded in improving both weight and capacity. The new lines gave pulse times varying from a third of a microsecond to three microseconds with impedances varying from five milliohms to fifty milliohms.

3.4 Experimental studies of oscillations and accompanying anomalous electron diffusion occurring in d.c. low density Hall type crossed field plasma accelerators

G. S. Janes and J. Dotson of Avco-Everett Research Laboratory

This type of accelerator operates under rather different conditions from the typical generator discussed earlier as can be seen from the typical experimental conditions that were quoted for Argon.

Axial Electric Field	20 volts/cm.
Mean Radial Magnetic Field	Less than or equal to 500 Gauss
Electron Density	$10^{10}$ to $10^{11}$ per cu. cm.
Electron Temperature	10 to 30 electron volts.
Final Ion Velocity	2 to $4 \times 10^6$ cm/sec.
Acceleration Length	13 cm.
Annulus Radii	4 cm and 10 cm.
Ion Gyro Radius	30 cm.
Ion Mean Free Path	Greater than 30 cm.
Electron Gyro Radius	About 0.02 cm
Dobye Length	Less than 0.01 cm.

The geometry used is essentially that of Fig.2B with the radial magnetic field provided by a short coil mounted about 20 cm from the near end of the annulus and with its axis coaxial with the axis of the annulus. One of the main points made in the paper is that the effective value of the Hall coefficient  $\omega_e \tau_e$  is considerably less than might be expected and turned out to have a value of about three. A reason for this is given that the ions which have small velocities near to the anode have to fall through the full accelerator potential before acquiring a velocity comparable with E/B. From this argument a very simple expression for the Hall coefficient is derived. Another point that was noted is that the electrons are not constrained by the magnetic field as well as might be expected and the reason given is the existence of instabilities that lead to fluctuations in the density and electric field of sufficient magnitude to account for the electron diffusion currents. The instability mechanisms have not yet been identified but W. Millar from Culham England asked if they could have been helicon waves.

3.5 Study of instabilities and transition to turbulence in a linear Hall accelerator  
R. V. Hess, J. Burlock, B. Sidney and P. Rookmann of Langley Research Center N.A.S.A.

This paper is based on similar apparatus to the previous paper, the radial magnetic field being obtained from two short coaxial coils mounted symmetrically on either side of the test region. The paper concentrates on the instabilities and notes that measurements are in progress to study the role of rotation and of screw motion and of density and magnetic field oscillations in the transition spectrum.

3.6 Experiments on a quasi-steady J x B accelerator  
R. L. Lennard and J. A. Fay of the Massachusetts Institute of Technology

The idea here is to use a shock tunnel apparatus to give a short period of steady flow through an accelerator channel. The working fluid is partially ionised Argon at about 12,000 degrees K and a pressure of about one mm of mercury. The shock tube arrangement and the x-T diagram are illustrated in Fig.4. From several runs a plot was given of the momentum balance, i.e. the acceleration effect achieved against the magnetic field parameter and experimental results were compared with the simple theory. The trend was broadly the same but the experimental points all fell below the theoretical line. This effect was explained by means of a laminar Hartmann boundary layer analysis but it may be questioned whether the one dimensional analysis is appropriate any how for a shock tube with such discontinuities.

3.7 Characteristics of a pulsed plasma accelerator  
T. Donner and W. McKilroy of the Republic Aviation Corporation

This refers to a different type of accelerator which is still basically an annular geometry with one end sealed off except for small entry ports. Hydrogen or nitrogen gas is admitted at these ports and serves to discharge a condenser bank. The resulting self generated magnetic field is such as to drive the conducting gas down the annulus eventually exhausting into a vacuum. The main purpose of the investigation was to try and explain a falling off in performance under repeated applications of the discharge which could not be accounted for by the simple "snow-plough" and "slug" theories. From many detailed probe experiments the following conclusions were quoted. Part of the discharge current appears to be concentrated in a thin front moving towards the exit of the accelerator at a high velocity. Current not associated with the front flows diffusely behind it, the fraction of the total current associated with the front decreasing as the front moves towards the accelerator's exit. The rate of change of flux in the inter-electrode space is a function of the current in the front and the velocity of the front. The velocity of the front and the fraction of the total current in this front are functions of the number of shots fired after the exposure of the accelerator to the atmosphere and of the gas used in the discharge. This latter fact is explained qualitatively by out-gassing from the electrodes and insulators. During the early discharges the out-gassing is at a maximum and augments the mass flow as well as improving the conductivity behind the front thus entraining still more gas within the port. In this way the out-gassing has a beneficial effect and as the out-gassing reduces with use so does the beneficial effect.

3.8 Experimental results of a travelling magnetic wave plasma engine  
R. E. Jones and R. W. Palmer of the N.A.S.A. St. Louis

The apparatus was not described in detail as it had already been covered in the third Conference but appeared to consist of a cylindrical tube inside a helical coil to which R.F. power was supplied at a frequency of 150 Kc/s. A radial field was supplied presumably from a short coil mounted some distance away along the axis of the tube and no doubt if this is excited at the same frequency pulses of gas will be driven along the tube. Apparently the efficiencies previously reported were as low as one per cent principally as a result of the high heat lost to the tube walls downstream of the last coil. This effect was removed by flaring the tube immediately downstream of the last coil and then experiments were made with various coil configurations. A four coil engine yielded a thrust based efficiency of nine per cent at a specific impulse of 3,500 seconds with Argon gas and twenty five per cent at an impulse of 4,000 seconds with Xenon gas. An attempt to improve the efficiency by using a one inch diameter ferrite core failed.

3.9 Status report on the design and test experience of a pilot M.H.D. accelerator for wind tunnel application  
A. K. Windmueller and L. E. Rittenhouse of Aro Inc.

The accelerator described was nominally rated at one megawatt and is being tested to demonstrate the feasibility of M.H.D. acceleration for wind tunnel application for a twenty megawatt unit. An arc heater initially operated with nitrogen and later with air, supplies a supersonic seeded plasma stream from a one by one inch nozzle exit at static temperatures up to 4,000 degrees K and static pressures in the 0.5 to one atmosphere range at a flow rate of 0.2 lb/second. The Hall current is minimised by segmenting the electrodes and the maximum magnetic field is twenty kilo Gauss. A good deal of the development has been concerned with the seeding problem, the seed being injected into a stilling chamber upstream of the nozzle. Both  $K_2CO_3$  and NaK have been investigated as possible seed materials and with the latter a conductivity as high as 1,000 mho per meter was achieved.

3.10 Optimum design of M.H.D. accelerators  
R. R. Gold, H. Mirels and J. F. Mullen of the Aro Space Corporation

This was an analytical investigation in which the net local power input, i.e. the product of the current the electric field and the channel area was assumed to have a power law variation with distance under conditions of constant electrical conductivity. The inlet and exit conditions were specified but the initial value of the local power input, the index of its dependence on distance and the length of the channel were treated as variables. The first two of these variables were optimised for minimum length.

4 BASIC PHYSICS

4.1 The conceptual design of an inductive energy storage system using ignitron switching  
E. D. Symon and G. Broner

The paper states that inductive energy storage systems are considered to be the most economical pulsed energy supplies for pulse lengths in the millisecond



to second range if more than  $10^5$  joules are required. The present idea is described as follows "The new system utilises an ignitron bridge circuit and a capacitor to invert from the unidirectional current of an inductive source to an alternating voltage of triangular waveform. The alternating voltage is used to charge and periodically recharge a small capacitor. This capacitor in its turn supplies energy to the load. Thus by the use of two capacitors whose maximum stored energy is very small compared to the total energy to be transferred the stored energy may be transferred to the load in discreet parcels." Evidently this system using inductive storage offers a big advantage in cost in the high energy range. During the presentation a graph was shown for the design of a system having a maximum voltage of twenty kilovolts and a maximum current of two kiloamperes in which the cost in cents per joule was plotted against the energy in joules. With log. scales the cost fell roughly linearly from ten cents per joule at an energy of  $10^6$  joules to 0.1 cent per joule at an energy of  $10^9$  joules.

4.2 Electrical resistance and sheath potential of a cold electrode in a shock tube with an applied magnetic field  
D. S. Wilson and D. L. Turcotte of Cornell University

In this paper a shock tube was used to investigate the behaviour of probes in the conducting fluid behind the shock. A diagram of the apparatus is given in Fig.5. The first and third probes were used to measure the speed of the shock and all detailed measurements were made with a central probe from which the current follows the path indicated in Fig.5. In the presence of an axial magnetic field the electrical resistance of the boundary layer is increased by the Hall effect and the Hall coefficient could be deduced from the voltage current characteristics. The results quoted showed a variation in the Hall coefficient divided by the magnetic field from 2.8 square metres per weber at ten cm behind the shock to 2.4 square metres per weber at forty cm behind the shock. This parameter was measured in the free stream at a value of nine square metres per weber and if that is converted to the wall temperature assuming constant pressure across the boundary layer a value of 2.3 square metres per weber is obtained. Agreement between these two values is good but it was suggested by a Questioner that it would have been more logical to use a mean value of  $\omega r$  taken through the boundary layer. The Lecturer thought that as the experiment deals with a sheath phenomenon it is not surprising to find that it is the wall temperature that is significant.

4.3 Radiant energy loss from a Cesium-Argon plasma to an infinite plane parallel enclosure  
M. Lutz of the Avco-Everett Research Laboratory

This paper gave the result of calculations from a uniform homogeneous plasma containing  $3 \times 10^{18}$  atoms of Argon per cu. cm and  $1 \times 10^{16}$  atoms of Cesium per cu. cm with a gas temperature of 2,000 degrees K and an electron temperature that was varied through the values 2,000, 2,500 and 3,000 degrees K. The results quoted were for continuous and line radiation to a wall distant one cm, ten cm and 100 cm from the edge of the plasma. It was found that the line radiation predominated in all cases although the proportion had fallen to eighty per cent at the highest electron temperature and over the highest distance.

4.4 The influence of the Ramsauer effect on non-equilibrium electron temperatures  
C. H. Kruger and J. R. Viegas of Stamford University

This paper put forward a theory intended to improve upon the usual assumption of an average electron collision frequency independent of the electron energy and an average energy loss per collision. It was stated by the Lecturer that the present theory has been found to agree with the Zukoski experiment better than the Zukoski theory.

4.5 Experimental investigation of non-equilibrium electrical conductivity in mercury vapour  
D. H. Polk of United Aircraft Research Laboratories

An electromagnetic R.F. discharge on a fifteen megacycles quarter wave resonator was used to produce a non-equilibrium plasma in a subsonic mercury vapour flow at static pressures and temperatures up to ten millimetres of mercury and 800 degrees K respectively. Measurements were made in the plasma downstream of the discharge of the magnitude and rate of decay of electrical conductivity, electron density, and electron temperature as functions of the discharge power vapour pressure and vapour temperature. Conductivities up to 400 mho per metre were obtained. Electron temperatures were in the range 6,000 to 7,000 degrees K. From the decay of electrical conductivity and electron density a two-body electron density decay coefficient was measured between  $0.6 \times 10^{-10}$  and  $1.5 \times 10^{-10}$  cu. cm per second and estimates of diffusion losses as well as the form of the time rate of decay indicated that this was largely the result of volume recombination. The average electron neutral collision cross-section determined from conductivity and electron density was  $4.5 \pm 1.5 \times 10^{-15}$  square cm. The experiments are being extended to mixtures of mercury and potassium.

4.6 Diffusion anomalies in quiescent magneto plasmas  
K. C. Rogers, F. G. Stern and H. Huger of the Stevens Institute of Technology

The apparatus is similar to that used at Princetown University by Rynn, D'Angelo, Motley and Wong who have written various papers about it. It is intended also to set up a similar device at the R.A.E. for the measurement of ion waves. A neutral beam of potassium or Cesium atoms is ionised on a hot tungsten plate and the resulting plasma is constrained within a cylinder by another hot tungsten plate at the other end together with an axial magnetic field. The present paper was concerned with instabilities that were found for magnetic fields of about 500 Gauss. When the density distribution across a section of the plasma column was found to contain strong peaks the instability was noted in the form of a.c. that showed up on the probe measurements and it disappeared very rapidly for higher magnetic fields. The electron density in the case quoted was of the order of  $10^{11}$ /cu. cm. It was also found that the instability faded out as the temperature was increased. An incidental note from this presentation was that the Authors evidently had to take a good deal of trouble in order to get the illumination of the plates uniform.

4.7 Interferometric measurements (Michelson) of rapid phase changes in the visible and near infra-red using a Laser light source  
R. G. Buser and J. J. Kainz of Fort Monmouth

Lasers are suggested as being a useful tool for probing a plasma. In particular it was stated that interferometer working in the infra-red will provide a very powerful diagnostic tool for the determination of characteristic plasma properties.

4.8 Current sheath dynamics and magneto sonic oscillations in magneto plasmas  
O. M. Friedrich Jnr. and A. A. Dougal of the University of Texas

The dynamics of a current sheath produced in a stabilised inverse pinch is studied experimentally and analytically. Magneto sonic oscillations of the current sheath predicted for weak stabilising fields of several hundred Gauss are observed experimentally.

5 SEEDING PROBLEMS

5.1 Seed reactions in M.H.D. power generation  
D. Q. Hoover, F. J. Kalano, W. T. Lindsay and S. M. DeCorso of Westinghouse

This paper described experiments in which attempts were made to simulate the flow through an M.H.D. generator. The combustion products were obtained by burning a slurry of fuel oil and four per cent by weight pulverised fly ash with a mixture of oxygen and nitrogen in an axial flow non swirling combustor. Seed was injected as a concentrated aqueous carbonate solution. At the downstream end of the flow a high efficiency dust filter was provided. The particles collected on the dust filter were about eighty per cent by weight soluble Cesium compound and a simple water leach of the product collected by the filter approached a ninety nine per cent recovery which is the figure aimed at for economic operation of a generator using Cesium as the seed. Treatment with one to two per cent of sulphuric acid resulted in solution of about ninety-five per cent of the total ash/seed mixture for an even greater Cesium yield of over ninety nine per cent. The question was put that since Cesium silicates occur in the ash and are soluble only in hydrochloric acid which is difficult to use, how did the Lecturer account for the high percentage recovery. The answer given was that only about five per cent of the Cesium occurred in ash and of this five per cent over eighty per cent was soluble in dilute sulphuric acid.

5.2 A method of seed recovery in coal fired M.H.D. power plants  
F. Howes and L. Keefe of the Avco-Everett Research Laboratory

In this paper the method of recovery was based on the fact that the seed is partially soluble in molten ash, i.e. slag at higher gas temperatures. The seed can then be precipitated from the molten slag and together with collected fly ash is simply recycled and re-injected into the system. Experiments with potassium seed have shown recovery efficiencies of the order of ninety per cent. On the other hand the experiments have indicated that catastrophic corrosion can be expected from seed in combination with ash and sulphur for metal heat

transfer surfaces operating above 1,530 degrees F. The reaction that produces the corrosion is that a mixture of potassium sodium sulphate reacts with chromium nickel or iron to give chromium, nickel or iron sulphate together with potassium and sodium hydroxide.

## 6 THEORETICAL MAGNETO GAS DYNAMICS

### 6.1 The magneto gas dynamic viscous shock layer in hypersonic flow S-Y Chen of Boeing

This paper reports an investigation on the feasibility of using an external magnetic field to reduce the heating rate in the stagnation region of a hemispherical nose in low density hypersonic flow. The shock layer is supposed to be concentric with the nose and to be compressible, viscous and thin, with constant electrical properties. The applied magnetic field is radial. The magnetic field requirements for a given percentage reduction in heating reduce with increasing altitude and increase in speed and at 400,000 ft 30,000 ft per second a reduction of forty-five per cent is possible with a field of twenty-four Gauss.

### 6.2 Hypersonic magnetohydrodynamics with or without a blunt body R. H. Levy, P. J. Gierasch and D. B. Henderson of Avco-Everett Research Laboratory

This was a major theoretical paper and is in fact the longest paper printed in full in the proceedings. The printed abstract reads "We consider the hypersonic flow of a cold gas past a two-dimensional or axially symmetric body containing a two or three dimensional magnetic dipole with its axis oriented parallel to the flow. The magnetic moment of the dipole and the size of the body are of arbitrary proportions. A uniform scalar of conductivity is turned on by the shock and the magnetic Reynolds number is low. For low values of the interaction parameter the flow is quasi-aerodynamic. Certain discrepancies existing in the literature on the flow in this regime are reconciled. At high values of the interaction parameter the nature of the flow is quite different. In this regime it consists of a thin deceleration layer (somewhat akin to the aerodynamic shock layer) and an extensive region of low Mach number flow (called the slow flow region) which separates the deceleration layer from the body. The gas in the slow flow region escapes outwards at sonic velocity along the field lines. In some circumstances the entire flow field can be supported by the magnet, i.e. without the hot gas touching the body. Assuming a large compression ratio across the shock a relatively simple analysis can be performed. Calculations covering various representative cases are exhibited. The validity and significance of these calculations are discussed." The interaction parameter referred to here is given by the product of the electrical conductivity, the radius of curvature of the shock and the square of the magnetic field strength divided by the product of the limiting compression ratio of the shock and the mass flow. The critical value of the interaction parameter that divides the two types of flow mentioned in the abstract, occurs when the product of the interaction parameter with the square root of the limiting compression ratio is of the order of one. For small values of this product (it is assumed throughout that the compression ratio is large compared with one) the features of the flow will be similar to those for pure aerodynamic flow around the same body. The analysis given in the paper concentrates on large values of the product and is split into a number of sections as follows:-

- (i) Study of the flow in the deceleration layer near the stagnation streamline.
- (ii) Study of the flow in the entire slow flow region.
- (iii) The matching of these two solutions at the back of the deceleration layer on the stagnation streamline.
- (iv) Study of the deceleration layer away from the stagnation streamline by the momentum integral method.

The type of results obtained are shown in Fig.6. The point is made that for sufficiently large values of the interaction parameter the size of the body shrinks to vanishing point and the whole of the shock system is supported by the magnetic dipole.

6.3 On a general variational principle in magneto fluid dynamics  
R. Balesou of Belgium

This paper was difficult to follow without having studied the previous work. It appears that Glansdorff and Prigogine have derived a general variational principle of evolution that the value of a certain integral over a system is always negative and vanishes at the steady state. The principle agrees with well known principles in the limits of purely dissipative evolution and purely non-dissipative evolution. The present paper considered the application of this principle to magneto fluid dynamics.

7 VISIT TO THE LARGE AVCO GENERATOR AT HAVERHILL (3RD APRIL)

This, the largest M.H.D. generator yet built, is a self-exciting generator with a designed useful output of twenty two MW. It has not yet been allowed to run up to full power. It is designed to run for three minutes, the limit being set by the uncooled magnet winding. The longest run before 3rd April had been forty seconds, at the end of which the magnetic field was still rising, and the output power was two MW. The design magnet consumption is eighteen MW.

The design is essentially a scaled-up version of earlier generators, except that the channel has two distinct sections, the upstream one being unsegmented and in series with the magnet, the downstream one being segmented (fifty pairs) and connected to the loads. (Other connections are also possible.) The upstream section was unsegmented because there is only one current path through the magnet. Also the density is higher and the Hall effect lower at the upstream end. In the downstream section  $\omega r$  is in the range one to two.

The burner uses  $O_2$  (sometimes diluted with  $N_2$ ) without preheat and with KOH dissolved in the ethyl alcohol fuel. A figure of two per cent K by moles in the products was quoted. The gas flow is eighty-six lb/second. The pressures are 120 p.s.i. in the burner, 65 p.s.i. at inlet to the channel and 15 p.s.i. at outlet. The areas of the channel are 1.36 square ft, 2.72 square ft and 5.28 square ft at inlet, between sections and outlet, the cross-section is square, and the lengths of the two sections are four ft and three and a half ft. The design Hall voltage in the segmented section is 1750 volts and the

maximum field is thirty five kilo Gauss. The design Mach number is in the region of 1.1 to 1.2 and the design stagnation temperature falls from 3100 degrees K to 2850 degrees K in the channel.

The side walls are cooled copper panels, and the electrodes are coated with sirconia which apparently conducts well enough at 800 degrees F. We did not see inside the channel.

During starting, batteries are used to excite the magnet until the generator self-excites and the batteries are automatically cut out.

Note that many of the figures given here were transmitted verbally and are liable to inaccuracy.

PART II

THE C.A.A.R.C. SYMPOSIUM ON LABORATORY STUDIES OF THERMALLY IONISED GASES  
HELD AT THE NATIONAL RESEARCH COUNCIL, OTTAWA  
ON 6TH, 7TH, AND 8TH APRIL, 1964

1 INTRODUCTION

In addition to the Canadian and United Kingdom representatives it was hoped that Dr. Bird representing Australia, Dr. Tirumalesa representing India and Dr. Axford representing New Zealand would be able to attend the meeting but unfortunately Dr. Bird was prevented from doing so. The Indian and New Zealand representatives both explained that very little research on this subject was being carried on in their countries so that the descriptive part of the meeting was almost wholly concerned with research being carried out in Canada and the United Kingdom. Since it is not the present purpose to report on United Kingdom work Part II of this paper is largely concerned with an attempt to survey the Canadian research in the field.

The delegates to the meeting were able to tour some of the Canadian laboratories as indicated below.

- (i) The Division of Mechanical Engineering of the N.R.C. with Dr. A. J. Bachmeier, the Canadian Co-ordinator in Hypersonics and Chairman of the meeting, Dr. P. Savio, Mr. E. H. Dudgeon and Mr. J. Lau.
- (ii) The Pure Physics Division of the N.R.C. with Dr. S. A. Ramsden.
- (iii) The Department of Mechanical Engineering, The University of Toronto with Dr. C. H. Miller.
- (iv) The Institute for Aerospace Studies, The University of Toronto with Dr. J. H. deLeeuw.

Others who attended the meeting and gave talks about the work of their own Group were:

- Dr. R. Nodwell, The University of British Columbia.
- Dr. R. W. Nicholls, The University of Western Ontario.
- Dr. J. H. T. Wu, The McGill University.
- Dr. M. P. Bachynski, The R.C.A. Victor Company Limited.

Some of the work of these eight groups is briefly described in Section 2 to 9 and in Section 10 a brief summary is given of Dr. Axford's talk based on his current work at Cornell University in the United States. The final discussion is summarised in Section 11.

## 2 MECHANICAL ENGINEERING DIVISION, N.R.C.

### 2.1 Plasma jet experiment

A plasma jet is being used for spectroscopic work above the sodium D-line temperature. The plasma jet consists of argon seeded with potassium hydroxide and the temperature distribution in the jet has been plotted using a photomultiplier technique. This works very well in a temperature range of the gas that has no prominent radiation line. The seed is chosen to have a few lines straddling the temperature and a photomultiplier count is carried out to give the intensity of each of the lines. It is then possible to plot radiation intensity against frequency and hence to deduce the temperature. In the experiments the electron density distribution was also found together with its variation with temperature both with and without seeding.

### 2.2 High velocity shock tube

A diagram of the shock tube arrangement is given in Fig.7. The shock tube is a double system in which compressed air is first used to drive a piston that compresses helium. When the helium has been compressed sufficiently it fractures a diaphragm and acts as a hot driver gas for an argon shock tube. The argon shock tube itself consists of a steel section followed by a somewhat smaller glass section which cuts out most of the boundary layer effects. The flow in the glass section can be examined by a camera through a revolving three-face mirror with a speed of 5,000 revolutions per second. Mach numbers in the test section of about twenty are used. Recent experiments have been concerned with the interaction of the high speed shock and the magnetic field produced by a short coil around the tube. The coil is energised from a 200 microfarad capacity bank which is discharged in time to give a reasonably steady magnetic field when the shock passes. The magnetic field results in a deceleration of the shock at the higher test pressures of four millimeters of mercury but at medium pressures of two millimeters there is first an acceleration followed by a deceleration, the former being caused by a tendency of the conducting fluid to follow the magnetic field lines which act as a converging nozzle in this region.

### 2.3 Theta pinch in argon

In this experiment a  $\theta$  pinch is produced by a discharge from a 300 microfarad bank of capacitors with a nominal energy rating of fifteen kilo joules. The rise time is about eight microseconds. Streak photographs have been taken for various gas pressures. In addition to a straight  $\theta$  pinch a conical end wall is also used and since the current sheet tends to be normal to the end wall it takes up a shape like part of a sphere so that an approximation to a self similar spherical shock is generated. Observations include the total current and voltage and magnetic probe and spectroscopic measurements. The main intention is to concentrate on the early stage of the pinch unlike the situation in thermo nuclear work where it is the closing stages of the pinch that are important. The experimental work is being supported by calculations based on Whitham's shock theory.



#### 2.4 Seeded shock tube experiments

In this experiment a fairly conventional argon shock tube is used with a cold hydrogen driver. The shock Mach numbers are in the range 10-12. The argon is seeded with cesium chloride smoke and this appears to have been accomplished quite successfully. Conductivity measurements have been made and compared with theory with particular reference to the fact that the early theories are known to have been wrong owing to the incorrect summing of collision frequencies in a gas mixture. The shock tube has also been run under reflected shocks without seeding.

The seeding has the advantage that the relaxation time is greatly reduced from about 200 microseconds for pure argon down to a few microseconds for seeded argon so that a considerable increase in useful running time is obtained. Also of course a given conductivity is achieved at a lower Mach number and this gives a further increase in running time. A possible future experiment consists in driving the conducting gas through an accurately conical magnetic field produced by the superposition of three or four coils. The flow would be studied visually and indirectly by heat transfer to the walls and possibly by pressure pick-ups on the walls.

### 3 THE PURE PHYSICS DIVISION, N.R.C.

The work here is being concentrated on the interaction of light in the form of laser beams with plasmas. Three experiments were described:

- (1) The scattering of a ruby laser beam by plasma.
- (2) The measurement of the Faraday rotation effect in a plasma with a magnetic field. The Faraday rotation is proportional to the product of the electron density and the magnetic field and it is intended to measure the former by means of a laser interferometer and the latter by means of magnetic probes. For this experiment a helium neon laser of 10 milliwatts power is proposed.
- (3) Development of the laser interferometer.

The capacity banks being set up include one of 300 joules for the  $\theta$  pinch of Experiment 1, a 10 kilo joule  $\theta$  pinch with a 200 kilo joule main bank for Experiment 2 and a 50 kilo joule bank available for a longitudinal magnetic field.

Of these three Experiment 1 was described in some detail since it has already been working for some time whereas the other two are planned for the near future. The experimental arrangement is shown in Fig.8. The light source is a Q-spoiled ruby laser giving a plane polarised output consisting of a single pulse of peak power about 10 megawatts and a half width of  $30 \times 10^{-9}$  seconds. Only a very small fraction of the incident light is scattered by the plasma the fraction being in the range  $10^{-13}$  to  $10^{-14}$ . In the circumstances stray light from the source has to be avoided as far as possible from reaching the detection system. Optical baffles and a dump chamber were used to this end but even so stray light at the laser wavelength was still a thousand times the intensity of the scattered beam and a double monochromator was used to observe the spectrum distribution of the scattered radiation. In the analysis a non-dimensional

parameter  $\alpha$  is important where  $\alpha$  is the reciprocal of the product  $kD$  and  $k$  is proportional to the sine of the half angle of scattering divided by the wavelength of the source and  $D$  is the Debye length proportional to the square root of the electron temperature divided by the electron density. For small values of  $\alpha$  the microscopic picture is seen and by use of a double monochromator a graph can be obtained of the intensity of the scattered light against the wavelength. The scattering in wavelength occurs as a result of a Doppler shift that arises from the electron velocities that cause the scatter, and the intensity plot is directly related to the Gaussian distribution of electron velocities in the plasma. The peak of the intensity distribution is not obtained as it occurs at the wavelength of the source where it is swamped by the stray light. The stray light is however negligible at wavelengths of plus or minus  $13\text{\AA}$  from the laser wavelength and quite a definite distribution curve could be obtained, and the electron velocity curve deduced from this was in good agreement with the electron temperature of the plasma measured by Stark broadening. An important feature of the work is that not only are the electron density and electron temperature determined (the former from the power of the scattered beam to which it is directly proportional and the latter from the wavelength distribution as indicated) but also the ion temperature can be determined by changing the direction of observation until the scattering angle is small. In this case the parameter  $\alpha$  is large and the macroscopic picture is seen in which the frequency width of the scattered beam depends on the ion temperature. It was also hoped that this type of experiment would throw some light on fundamental ideas such as whether the concept of a Debye length is a useful one or not.

4 THE MECHANICAL ENGINEERING DEPARTMENT, THE UNIVERSITY OF TORONTO

The visit here was greatly curtailed by the weather which delayed the flight to Toronto by over four hours. Some work has been done on a plasma propulsion device where the plasma is obtained by flow through an arc heater. The arc is struck across an annular gap and takes a current of the order of 500 amps with a voltage of 30 to 40 volts. An axial magnetic field of 12 kilo Gauss drives the arc round the annulus. The flow through the annulus is subsonic with downstream velocities of the hot gas of up to 1,000 meters/second. No attempt is made to oppose the force on the arc that the gas stream may exert by means of a circumferential magnetic field. The pressures are in the range of 2-10 millimeters of mercury. It was found that if the central electrode was the cathode and the magnetic field pointed upstream to the flow direction then the arc configuration was stable whereas if the direction of either the magnetic or the electric field was reversed the arc became unstable.

It is planned to carry out experiments in the plasma-jet wind-tunnel that can be run from this arc heater, and one such experiment of considerable interest is to investigate microwave propagation through the flowing plasma from a slot aerial in a cylindrical body.

5 THE INSTITUTE FOR AEROSPACE STUDIES, THE UNIVERSITY OF TORONTO

An experiment on the non-equilibrium flow over an expansion corner was being made in a shock tube. The shock tube had a cross section of 4 x 7 inches and the low pressure section was 40 feet long and designed for pressures of up to 2,500 p.s.i. with a driver pressure of 20,000 p.s.i. The

particular experiment exhibited had an expansion angle of fifteen degrees and pressure gauges at four points around the expansion corner one being upstream and three downstream. Interferometer measurements were also being made.

Another experiment made use of a heated shock tube in which the test gas was either argon or helium seeded with cesium vapour at a temperature of about 200 degrees C. The object of the experiment was to investigate the boundary layer flow along the wall of the shock tube with particular reference to the transition from laminar to turbulent flow in the presence of a transverse magnetic field. A reason for pre-heating the tube is that this results in a lower temperature ratio between the shocked gas and the wall without which the boundary layer would be too stable and no transition would occur within a practical length. Another practical gain from heating the tube is that it makes the seeding problem so much easier as the cesium can be allowed to take up its own vapour pressure. The temperature of the hot gas was in the range 3,000-5,000 degrees K and the conductivity was measured to be about ten mhos per meter. One feature of the test was that the force in the boundary layer derived from the interaction of the magnetic field is sufficient eventually to balance the shearing force so that no further boundary layer growth occurs. By reason of its constancy this region of the boundary layer is then very suitable for investigating the detailed physics both in theory and experiment.

A third experiment was the investigation of the behaviour of electrically charged bodies in a rarified plasma through the transition from free molecular flow to the flow of a continuum fluid. One of the objects of the experiment was to answer the question of whether charge pick-up occurs and if so in what circumstances. Another experiment was a study of the effect of an axial magnetic field on the stand-off distance of shocks on bodies in a small ionising shock-tube, using visual observation of shock position.

#### 6 THE UNIVERSITY OF BRITISH COLUMBIA

The reason for setting up a plasma physics group here was stated to be first that plasmas are found so universally in nature and secondly plasmas are so powerful that their practical application is likely to become widespread in the near future. It is therefore important to try to understand more about their fundamental nature and behaviour. A brief list of their activities is as follows.

- (1) Linear pinch work and associated instabilities.
- (2) Shock tube work.
- (3) Work in T-type shock tube. Here the electron temperature and density were being measured and a difficulty was being experienced in getting a plane wave front owing to the presence of considerable turbulence.
- (4) Spark gap recovery.
- (5) Spectroscopy.

Most of the work is optical and progress under items 2 and 4 is held up at the moment since those concerned with the experiments have recently left the University.

7 THE UNIVERSITY OF WESTERN ONTARIO

Research here includes a good deal of spectroscopic work. In particular they are in the process of mapping the molecular spectra of all the rare earth metals by exciting them in shock tubes.

8 MCGILL UNIVERSITY

Experiments are in hand on the interactions of strong shock waves and detonation waves with magnetic fields possessing axi-symmetry. The shock tube arrangement is very similar to that of the Mechanical Engineering Division, N.R.C., shown in Fig.7. Compressed air is used to compress helium which then acts as the driver in an argon shock tube and shock Mach numbers of twenty-six at an initial pressure of 500 microns can be reached. The magnetic field is obtained by discharging a capacitor bank of 300 microfarads and four kilovolts giving a total of 2,400 joules through the coil. This gives a relatively steady d.c. field for a period of fifty microseconds and an intensity such that the radial component of the magnetic field reaches two kilo Gauss. For the detonation wave experiments it is intended to use the same magnetic field arrangement with the coil placed round a detonation tube containing acetylene and oxygen in different mixture ratios with ignition by means of an exploding wire. The experimental work is supported by theoretical work based on an assumption of low magnetic Reynolds number in the case of the shock interaction. In addition it is intended to investigate the degree of ionisation and the electrical conductivity behind both the strong aerodynamic shocks and the detonation waves both theoretically and experimentally. The effect of seeding will also be studied.

Another programme concerns the theory and experiment of cylindrical detonation waves. A thin copper wire is mounted along the axis of the cylinder and detonation is achieved by discharging a bank of capacitors through the wire. A theoretical analysis including digital computer solutions has been carried out. It is intended to adapt the same apparatus to study an imploding detonation.

Another experiment concerned with detonation waves is to investigate their interaction with a wire screen with particular reference to the transmitted wave. Preliminary results indicate that the transmitted and incident wave both propagate at the same velocity and that initial pressures, mixture ratio and screen porosity have no effect on the transmitted wave.

9 THE R.C.A. VICTOR COMPANY LIMITED

There is a strong and energetic plasma group here which has issued about eighty reports in the last four years and it was no doubt a pity that lack of time prevented a visit to their laboratories. Much of their work has been concerned with plasma diagnostics. One example given was the development of special equipment for measuring the amplitude and phase of a signal in which a polar plot of the real and imaginary parts of the vector was obtained directly. Considerable experience has been gained with the use of double probes for measuring electron density, and magnetic probes which they had found extremely useful. A particular example of the use of magnetic probes was concerned with a model of the solar wind flowing past a terella. They had

evidently managed to achieve the correct order of magnetic Reynolds number and Dr. Bachynski showed a number of slides of the interaction. Magnetic probes were used to examine the magnetic field distribution both before and after it was perturbed by the flow. The caution was made that because no visible light was seen it should not be assumed that there was no plasma present as they had demonstrated otherwise by probe measurements. Reference to three papers dealing with this work is given here for convenience.

- 1 I. P. Shkarofsky - The solar wind, the magnetosphere and their simulation in the laboratory.  
R.C.A. Victor Research Report 7-801-22  
October, 1962.
- 2 M. P. Dachynski - Simulation of geophysical phenomena in the laboratory.  
R.C.A. Victor Research Report 7-801-27  
August, 1963.
- 3 F. J. F. Osborne - Laboratory simulation of the solar wind  
I. P. Shkarofsky magnetosphere interaction.  
J. V. Gore Canadian Journal Physics, Volume 41,  
pp.1747-1752, November, 1963.

10 AXFORD'S WORK AT CORNELL UNIVERSITY

His interest is in real plasmas within the solar system or in inter-stellar space. He described three problems:

(1) Collision free shocks. These were first considered by Gold in 1953 and an example of great interest is the interaction of the solar wind with the magnetosphere surrounding the Earth. The possible existence of such a shock has been the subject of considerable discussion in recent times. If it exists it must be collision free because the particle density is extremely low and the temperature very high of the order of  $10^6$  degrees K so that the mean free path (which increases rapidly with temperature in a fully ionised gas) is very large even compared with the dimensions of the magnetosphere. Work in this field has recently received a great boost by the fact that instrumentation on the satellite Imp has recently given a clear record of the presence of the shock which is found to have a thickness of the order of 5,000 kilometers, say between one and ten Larmor radii.

(2) The merging time of magnetic fields. Magnetic fields embodied in gaseous conductors can merge with each other under suitable conditions with a mutual cancellation effect such that energy is released. This possibility has received considerable study recently in the search for an explanation of solar flares where large energy of the order of  $10^{32}$  ergs is released in a very short time. Magnetic fields adjacent to sun spots have the requisite energy content of the order of 100-1,000 Gauss but most models of the merging process result in a release time that is far too long. Very recently Petschek in an Avco report has put forward a theory that the initial merging process near the neutral point is soon

taken over by a switch off shock that propagates rapidly away from the neutral point and this reduces the time scale from the order of a month down to a few minutes such as is observed in real solar flares.

(3) The acceleration of fast particles of the order of  $10^{20}$  electron volts in inter-stellar space.

With regard to the description of the merging time of magnetic fields it is felt here at the R.A.E. that Petschek's theory may well be unsatisfactory following certain comments which are believed to have first been made by E. N. Parker. The criticism is concerned with the fact that if one draws out a practical distribution of magnetic field then it is impossible to provide magnetic field lines of the right curvature and strength for the switch off shock to take over from the ordinary merging procedure anything like soon enough to satisfy the time requirement.

#### 11 GENERAL DISCUSSION AND CONCLUSIONS

It was generally felt that the subject of plasma physics covers such a wide range of interest that it would be difficult at any rate at present to attempt much in the way of formal co-ordination of work throughout the Commonwealth. In the present discussions for example the range of pressures mentioned varied from 1,000 atmospheres or so down to say a micron and then on down to virtually zero in the case of collision free plasma such as the solar wind. Other ranges of interest include a temperature range from say 1,000 to 1,000,000 degrees K, a power range from fractions of a milliwatt to hundreds of a megawatt or of course much higher still in the case of solar phenomena such as solar flares, and a kinetic to magnetic pressure ratio that ranged virtually from zero to infinity. All of this involves a tremendous range of experimental facility, e.g. spectroscopy, microwaves, high speed cameras, interferometers, probes, shock tubes, liquid metal facilities, discharge tubes of various kinds, all sorts of magnetic fields, heavy engineering in the shape of large capacity banks and high power magnetohydrodynamic power generators and accelerators, and finally items appropriate to space research such as plasma thrust devices and instrumented satellites. There is a similar range in theoretical work from continuum magnetohydrodynamics to a solution of the collision free Boltzmann equation both of which have a very wide range of application and also the study of relaxation effects and particle interaction and so forth. Although a complete co-ordination over such a wide field was felt to be impractical there is clearly a good case for workers within the Commonwealth to keep in touch with each other in their respective spheres of interest. A practical way of doing this might be for Commonwealth delegates to an International meeting such as the Engineering Aspects of Magnetohydrodynamics described in Part I of this paper to stay on for another day and to compare notes with each other.

The meeting was wound up by discussing a draft report which after a few amendments read as follows:

(1) As physicists with widely diversified interest in the field of plasma physics the delegates did not believe the knowledge of plasma behaviour was sufficiently advanced for them to recommend a much

increased engineering participation at this time. However the universality of plasmas and the generality of the physics involved make research into plasma behaviour and properties worthy goals in themselves without consideration of immediate applications. Because of this wide basis for plasma studies many applications involving a knowledge of ionised gas properties will certainly occur in the future.

(2) The increased attention of fluid dynamicists and aerodynamicists now concerned with more conventional aerodynamics to problems involving ionised gases would be beneficial and should be encouraged. It was considered that as more extreme conditions were reached in aerodynamic development, e.g. in the development of hypersonic vehicles, magnetohydrodynamic power generation etc., aeronautical research would become more involved in plasma problems.

(3) The delegates considered that C.A.A.R.C. could make an effective contribution to the field of plasma research now by providing opportunities for small meetings concerning particular aspects of ionised gas behaviour. These could include such subjects as clean plasma generation for hypersonic aerodynamic studies, plasma diagnostics, waves, communication through ionised gases, stellar phenomena such as solar flares which could influence the safety of high altitude flight, magnetohydrodynamic power generation and plasma propulsion. Such meetings could provide forums for the exchange of views and point out specific areas which required further attention. This could lead to shared research programmes among Commonwealth countries where countries with specific applications requiring an extensive study of certain aspects of plasma behaviour could encourage other countries with only a general interest to undertake research that would be of mutual benefit.

Such meetings with restricted objectives sponsored by C.A.A.R.C. would enable this organisation to be kept informed of developments in plasma physics so that it could recommend quickly a suitable wider participation by aeronautical organisations when future problems arise.

In the above report special mention was made of magnetohydrodynamic power generation because it was felt that this subject had been rather sparsely mentioned in the main discussions although it was no doubt the field of most immediate engineering application on a large scale. The point was made that the design of a power generator involving high speed flow is very much a branch of aeronautics and has of course involved a good many aeronautical engineers in the United States.

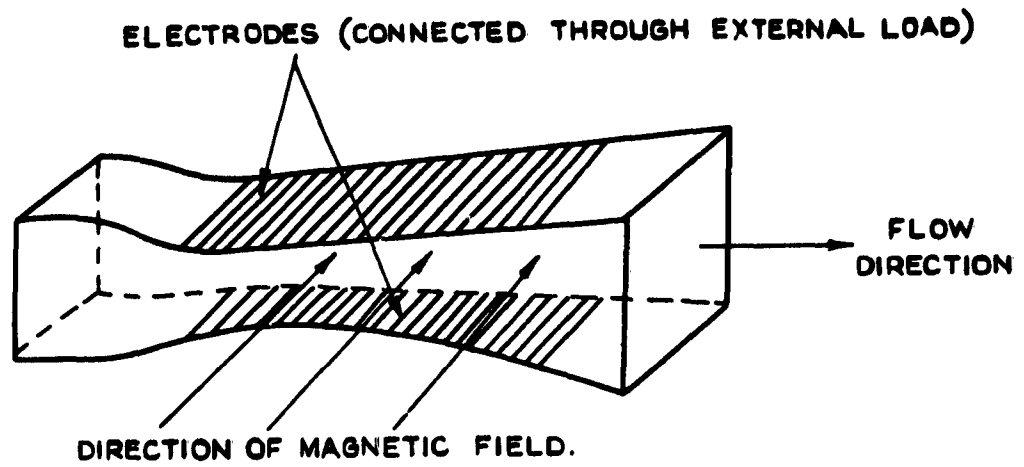

(a) CONTINUOUS ELECTRODES

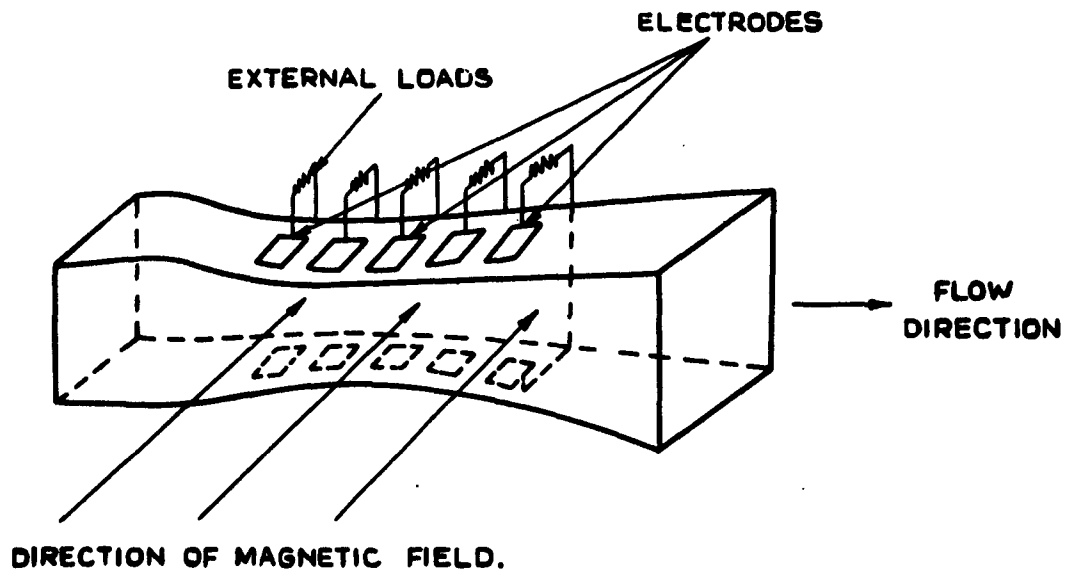

(b) SEGMENTED ELECTRODES

FIG. 1 SIMPLE CHANNEL-TYPE M.H.D. GENERATORS



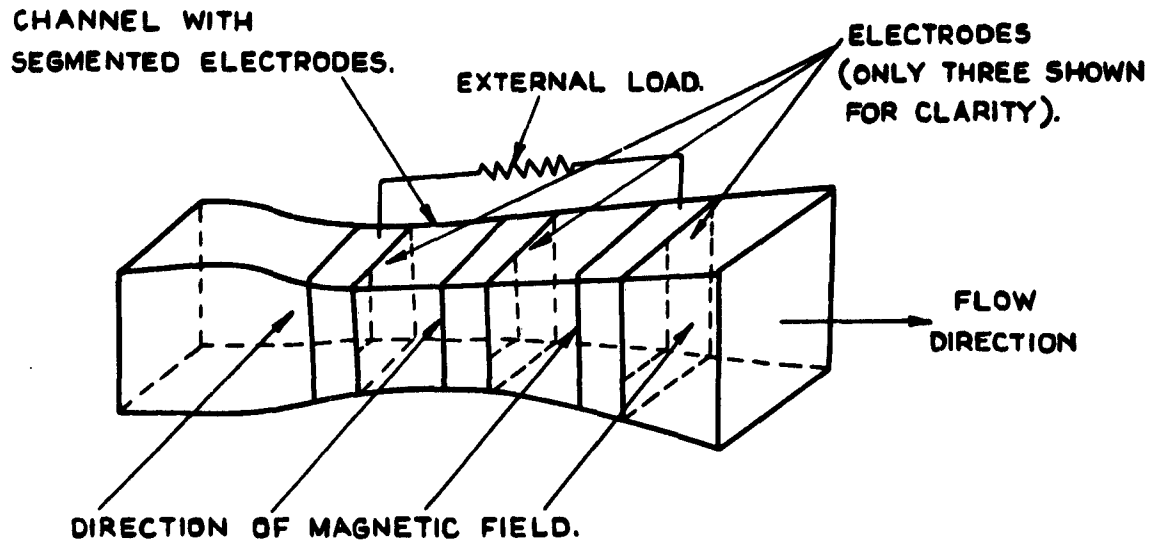

(a) CHANNEL TYPE WITH SEGMENTED ELECTRODES

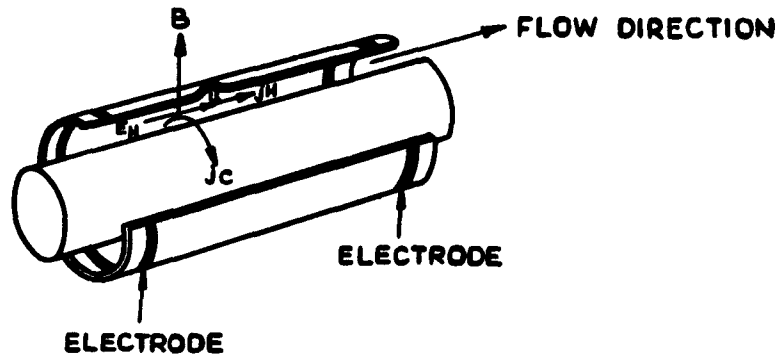

(b) COAXIAL HALL GEOMETRY

FIG. 2 VARIOUS TYPES OF HALL-CURRENT GENERATOR

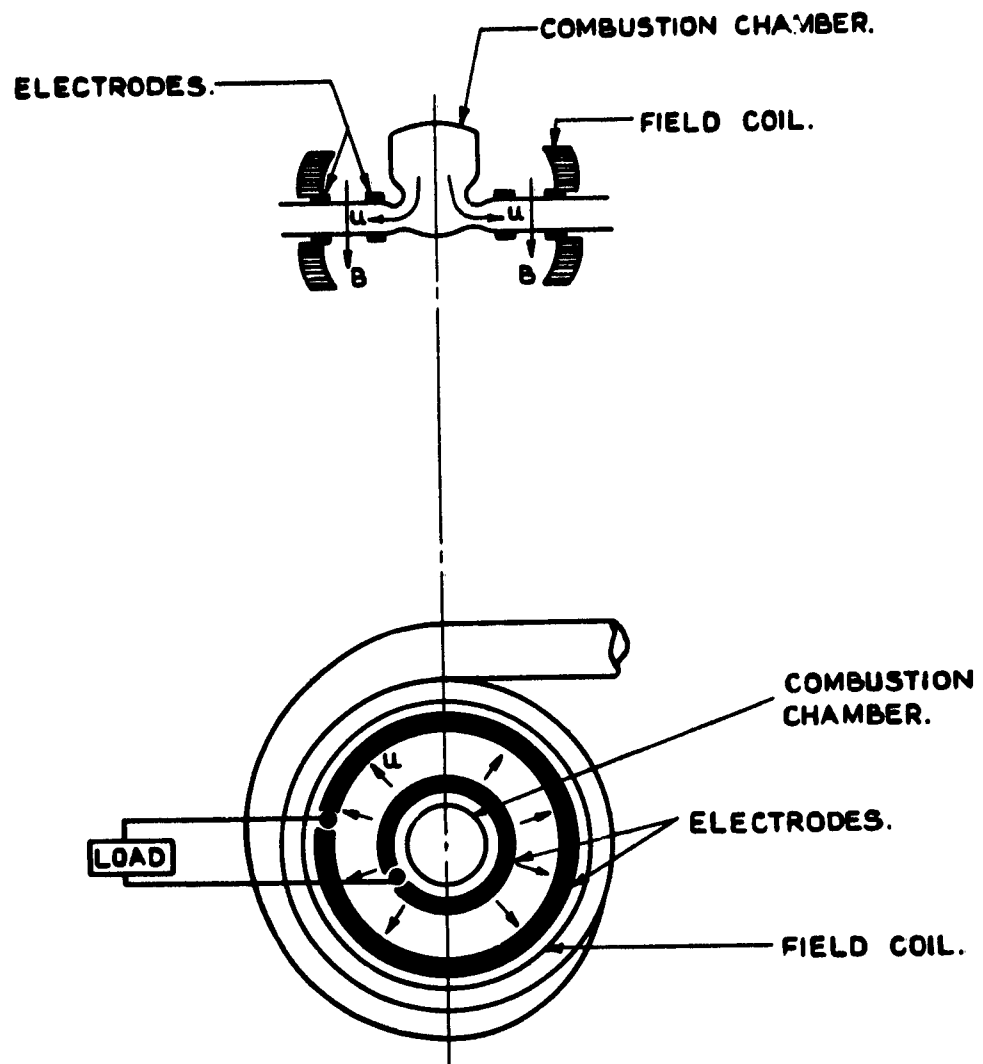

(c) DISK HALL GENERATOR GEOMETRY

FIG.2 VARIOUS TYPES OF HALL CURRENT GENERATOR

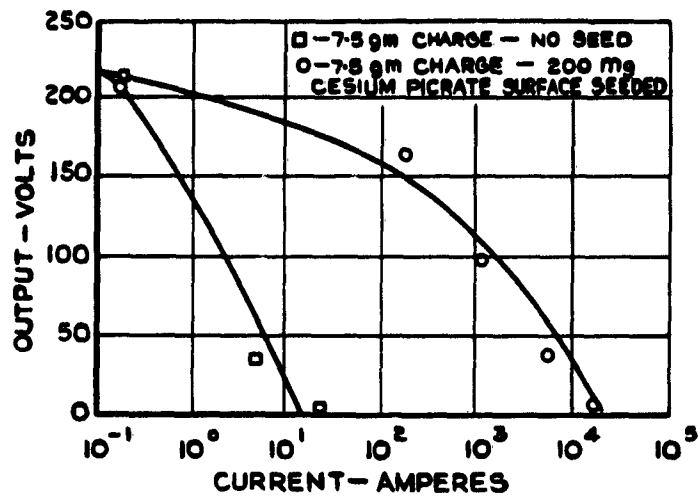

FIG. 3 COMPARISON OF SEEDED AND NON-SEEDED SHAPED CHARGES IN 1 INCH BY 1 INCH EXPLOSION DRIVEN M.H.D. GENERATOR (M.H.D. REASARCH INC)

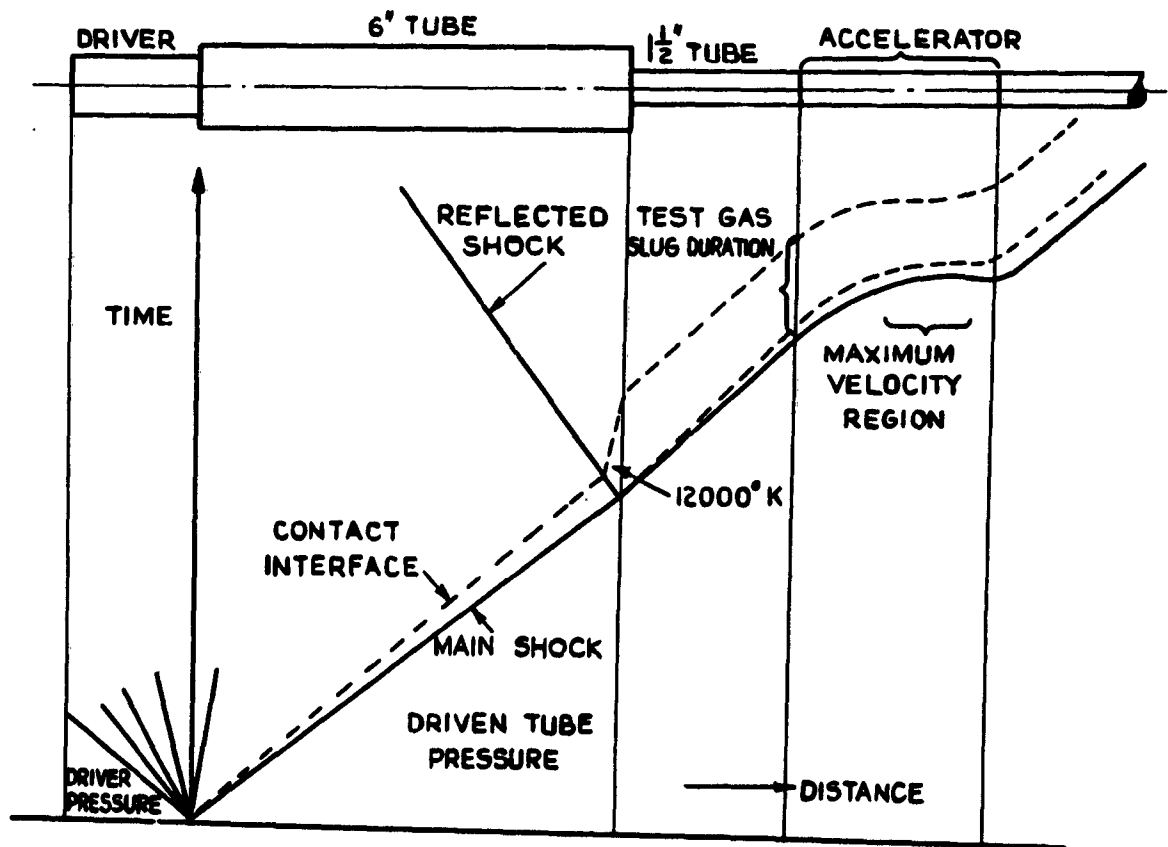

FIG. 4 THE x-t DIAGRAM FOR THE SHOCK TUBE AND ACCELERATOR (M.I.T.)

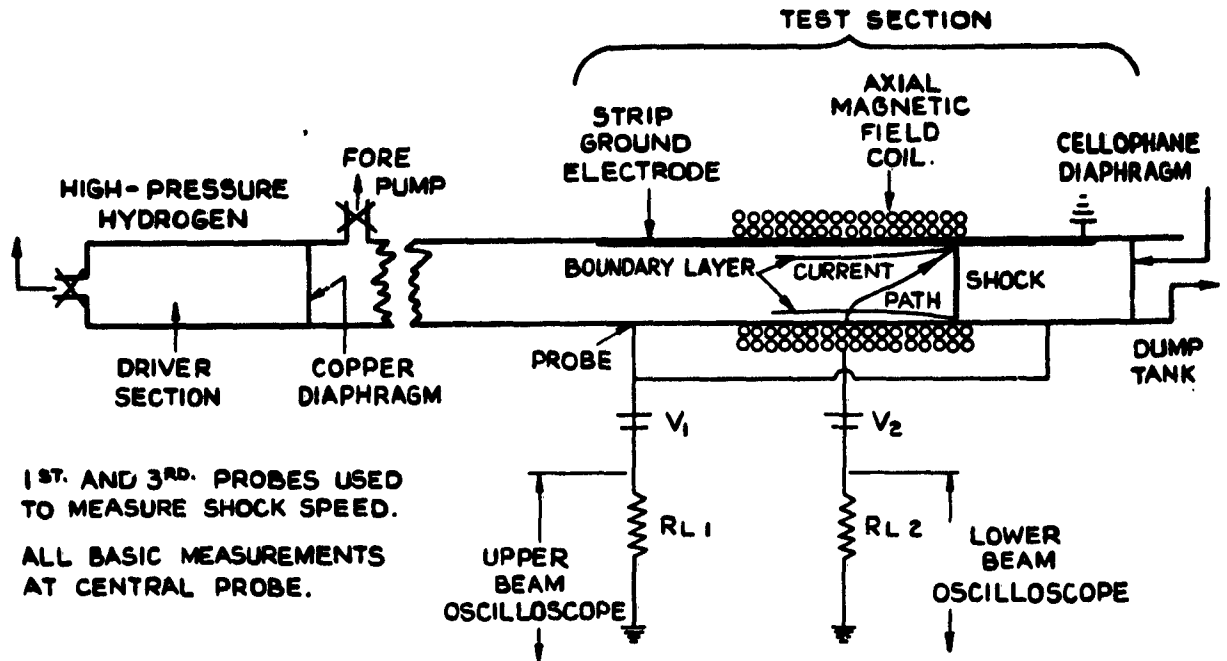

FIG.5 SHOCK TUBE AND ASSOCIATED CIRCUITRY (CORNELL UNIVERSITY)

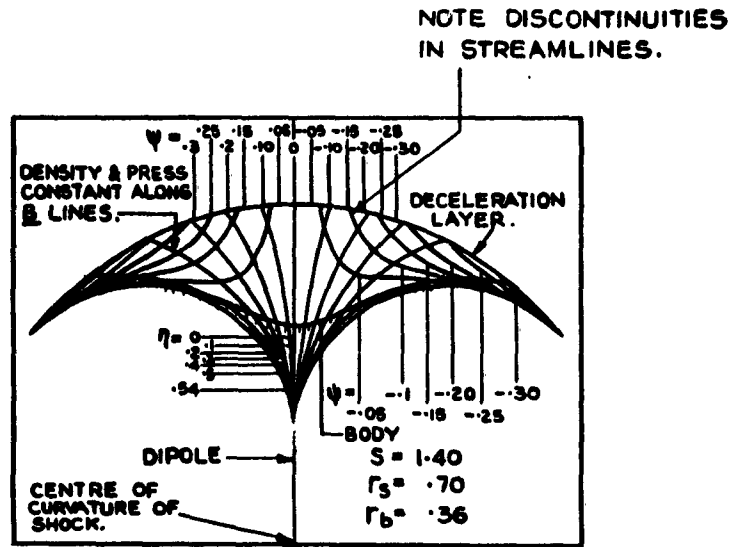

FIG.6 CALCULATED STREAMLINES FOR THE SHOCKED FLOW PAST A MAGNETIC DIPOLE (AVCO-EVERETT)

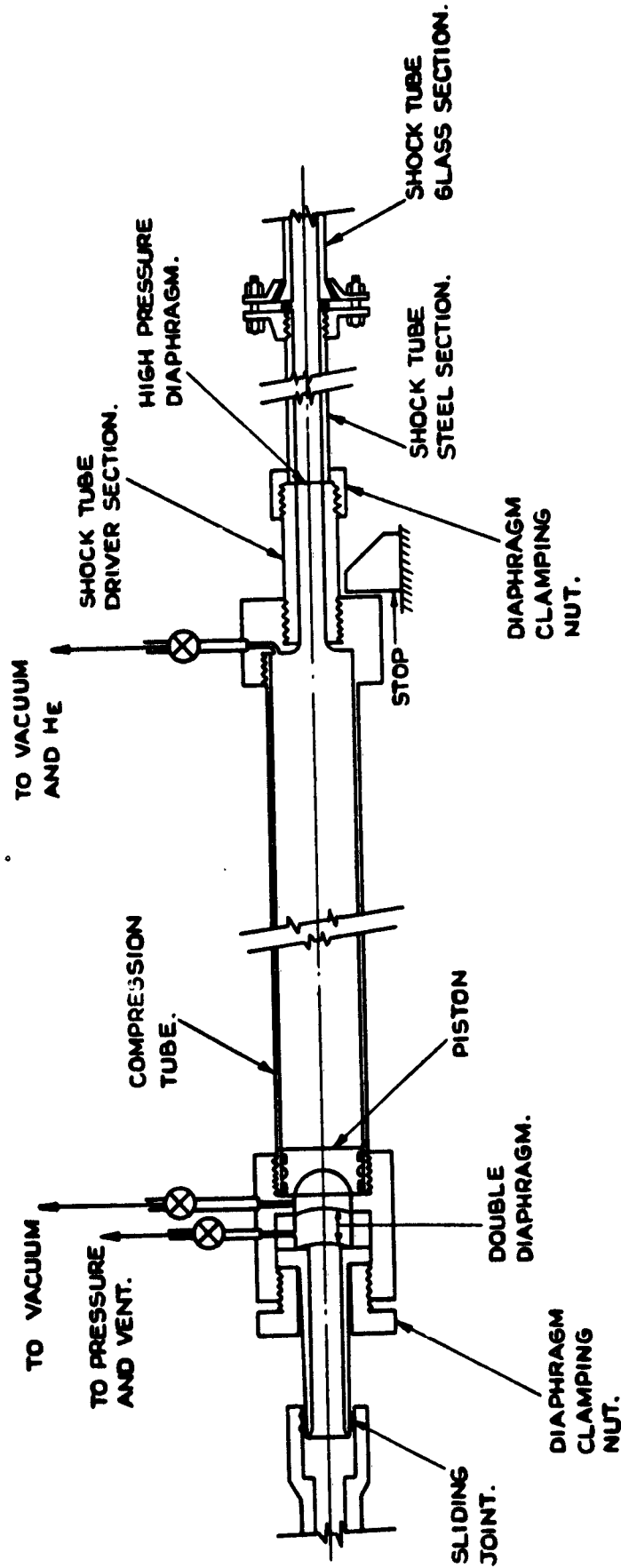

FIG.7 COMPRESSION TUBE AND SHOCK TUBE DETAILS (N.R.C.)

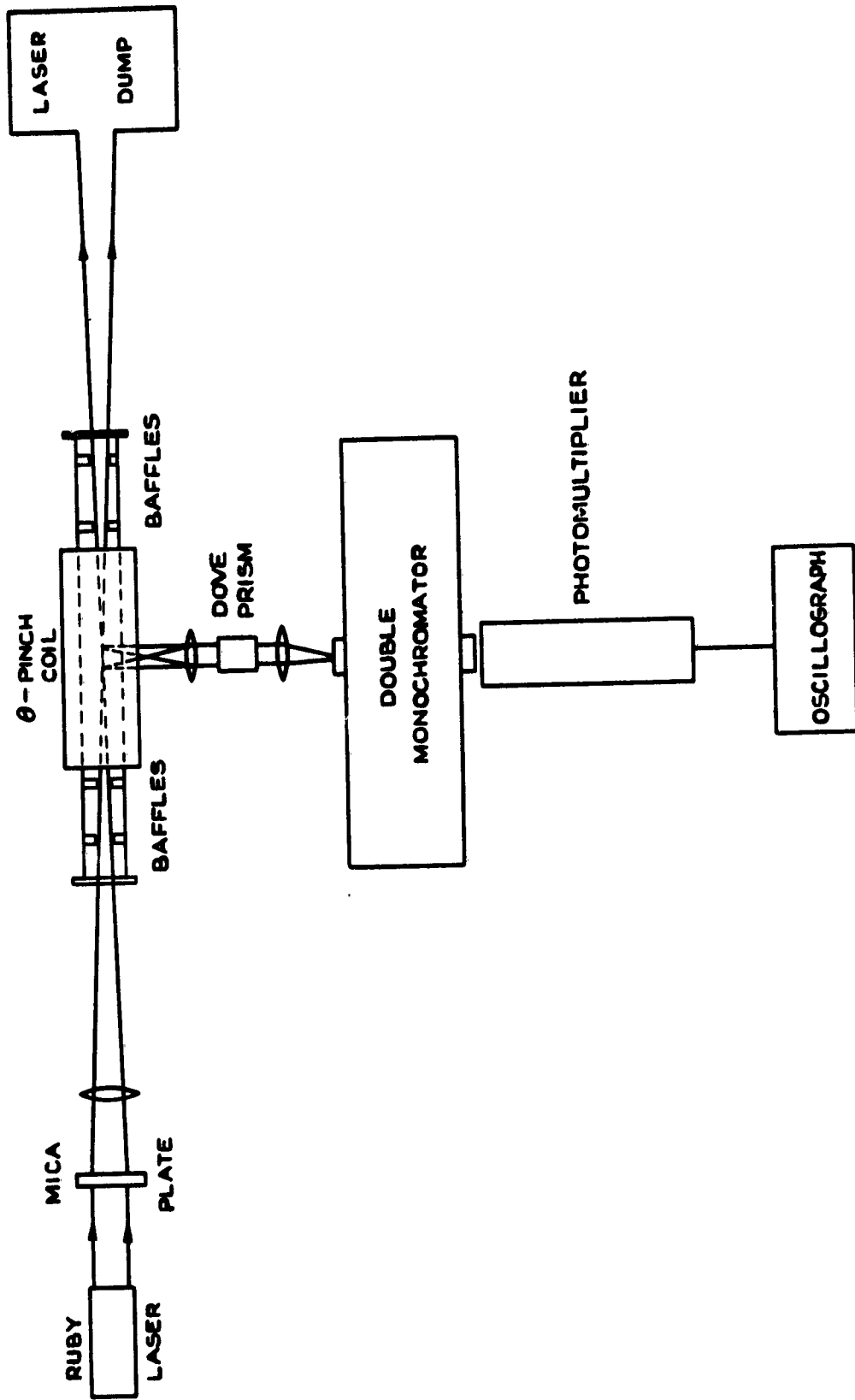

FIG. 8 SCATTERING OF LIGHT FROM ELECTRONS IN A PLASMA  
EXPERIMENTAL ARRANGEMENT (N.R.C.)

DETACHABLE ABSTRACT CARDS

These abstract cards are inserted in Reports and Technical Notes for the convenience of Librarians and others who need to maintain an Information Index.

<p>Technical Note No. Aero 2984 Royal Aircraft Establishment</p> <p>NOTES ON: (1) THE 5TH SYMPOSIUM ON ENGINEERING ASPECTS OF MAGNETOHYDRODYNAMICS (2) A C.A.A.R.C. MEETING ON LABORATORY STUDIES OF THERMALLY IONISED GASES - APRIL 1964. Broadbent, E.G. August 1964.</p> <p>538.3 : 532.5 : 537.56 : 06.076(7+73) : 061.3</p> <p>This paper is a collection of Notes on the two meetings mentioned in the title which were held respectively at The Massachusetts Institute of Technology on the 1st and 2nd April 1964, and in Ottawa and Toronto, on the 6th, 7th and 8th April, 1964, and were attended by three representatives of the United Kingdom under the sponsorship of the Ministry of Aviation namely:</p> <p>D. L. Schultz, Oxford University J. A. Shercliff, Cambridge University E. G. Broadbent, Aerodynamics Department, R.A.E.</p> <p align="right">(Over)</p>	<p>Technical Note No. Aero 2984 Royal Aircraft Establishment</p> <p>NOTES ON: (1) THE 5TH SYMPOSIUM ON ENGINEERING ASPECTS OF MAGNETOHYDRODYNAMICS (2) A C.A.A.R.C. MEETING ON LABORATORY STUDIES OF THERMALLY IONISED GASES - APRIL 1964. Broadbent, E.G. August 1964.</p> <p>538.3 : 532.5 : 537.56 : 06.076(7+73) : 061.3</p> <p>This paper is a collection of Notes on the two meetings mentioned in the title which were held respectively at The Massachusetts Institute of Technology on the 1st and 2nd April 1964, and in Ottawa and Toronto, on the 6th, 7th and 8th April, 1964, and were attended by three representatives of the United Kingdom under the sponsorship of the Ministry of Aviation namely:</p> <p>D. L. Schultz, Oxford University J. A. Shercliff, Cambridge University E. G. Broadbent, Aerodynamics Department, R.A.E.</p> <p align="right">(Over)</p>
<p>Technical Note No. Aero 2984 Royal Aircraft Establishment</p> <p>NOTES ON: (1) THE 5TH SYMPOSIUM ON ENGINEERING ASPECTS OF MAGNETOHYDRODYNAMICS (2) A C.A.A.R.C. MEETING ON LABORATORY STUDIES OF THERMALLY IONISED GASES - APRIL 1964. Broadbent, E.G. August 1964.</p> <p>538.3 : 532.5 : 537.56 : 06.076(7+73) : 061.3</p> <p>This paper is a collection of Notes on the two meetings mentioned in the title which were held respectively at the Massachusetts Institute of Technology on the 1st and 2nd April 1964, and in Ottawa and Toronto, on the 6th, 7th and 8th April, 1964, and were attended by three representatives of the United Kingdom under the sponsorship of the Ministry of Aviation namely:</p> <p>D. L. Schultz, Oxford University J. A. Shercliff, Cambridge University E. G. Broadbent, Aerodynamics Department, R.A.E.</p> <p align="right">(Over)</p>	<p>Technical Note No. Aero 2984 Royal Aircraft Establishment</p> <p>NOTES ON: (1) THE 5TH SYMPOSIUM ON ENGINEERING ASPECTS OF MAGNETOHYDRODYNAMICS (2) A C.A.A.R.C. MEETING ON LABORATORY STUDIES OF THERMALLY IONISED GASES - APRIL 1964. Broadbent, E.G. August 1964.</p> <p>538.3 : 532.5 : 537.56 : 06.076(7+73) : 061.3</p> <p>This paper is a collection of Notes on the two meetings mentioned in the title which were held respectively at the Massachusetts Institute of Technology on the 1st and 2nd April 1964, and in Ottawa and Toronto, on the 6th, 7th and 8th April, 1964, and were attended by three representatives of the United Kingdom under the sponsorship of the Ministry of Aviation namely:</p> <p>D. L. Schultz, Oxford University J. A. Shercliff, Cambridge University E. G. Broadbent, Aerodynamics Department, R.A.E.</p> <p align="right">(Over)</p>

The paper is based on notes taken by these three individuals together with a pre-print of the proceedings of the Magnetohydrodynamics Symposium and one or two papers that were given out by individuals during the C.A.A.R.C. meeting.

One of the main subjects of the Magnetohydrodynamics Meeting was that of Power Generation in which considerable progress has been made in the study of generator operation at supersonic speeds including shock effects and in experiments with geometries of Hall type generators. A number of papers were given on accelerators and several more on related topics in experimental physics. There were one or two papers specifically on seeding problems and others on hypersonic flow round blunt bodies.

With regard to the C.A.A.R.C. meeting the present paper is mainly devoted to a summary of the work being carried out in Canada. The conclusions of the meeting are also reported.

The paper is based on notes taken by these three individuals together with a pre-print of the proceedings of the Magnetohydrodynamics Symposium and one or two papers that were given out by individuals during the C.A.A.R.C. meeting.

One of the main subjects of the Magnetohydrodynamics Meeting was that of Power Generation in which considerable progress has been made in the study of generator operation at supersonic speeds including shock effects and in experiments with geometries of Hall type generators. A number of papers were given on accelerators and several more on related topics in experimental physics. There were one or two papers specifically on seeding problems and others on hypersonic flow round blunt bodies.

With regard to the C.A.A.R.C. meeting the present paper is mainly devoted to a summary of the work being carried out in Canada. The conclusions of the meeting are also reported.

The paper is based on notes taken by these three individuals together with a pre-print of the proceedings of the Magnetohydrodynamics Symposium and one or two papers that were given out by individuals during the C.A.A.R.C. meeting.

One of the main subjects of the Magnetohydrodynamics Meeting was that of Power Generation in which considerable progress has been made in the study of generator operation at supersonic speeds including shock effects and in experiments with geometries of Hall type generators. A number of papers were given on accelerators and several more on related topics in experimental physics. There were one or two papers specifically on seeding problems and others on hypersonic flow round blunt bodies.

With regard to the C.A.A.R.C. meeting the present paper is mainly devoted to a summary of the work being carried out in Canada. The conclusions of the meeting are also reported.

The paper is based on notes taken by these three individuals together with a pre-print of the proceedings of the Magnetohydrodynamics Symposium and one or two papers that were given out by individuals during the C.A.A.R.C. meeting.

One of the main subjects of the Magnetohydrodynamics Meeting was that of Power Generation in which considerable progress has been made in the study of generator operation at supersonic speeds including shock effects and in experiments with geometries of Hall type generators. A number of papers were given on accelerators and several more on related topics in experimental physics. There were one or two papers specifically on seeding problems and others on hypersonic flow round blunt bodies.

With regard to the C.A.A.R.C. meeting the present paper is mainly devoted to a summary of the work being carried out in Canada. The conclusions of the meeting are also reported.





*Information Centre  
Knowledge Services*  
**[dstl]** *Porton Down*  
*Salisbury*  
*Wiltshire*  
*SP4 6JQ*  
*22060-6218*  
*Tel: 01980-613753*  
*Fax 01980-613970*

Defense Technical Information Center (DTIC)  
8725 John J. Kingman Road, Suit 0944  
Fort Belvoir, VA 22060-6218  
U.S.A.

AD#: AD453253

Date of Search: 2 July 2008

Record Summary: DSIR 23/32303

Title: Notes on 5th Symposium on Engineering Aspects of Magnetohydrodynamics and CAARC Meeting on Laboratory Studies of Thermally Ionized Gases (RAE TN Aero 2984)  
Availability Open Document, Open Description, Normal Closure before FOI Act: 30 years  
Former reference (Department) ARC 26466  
Held by The National Archives, Kew

This document is now available at the National Archives, Kew, Surrey, United Kingdom.

DTIC has checked the National Archives Catalogue website (<http://www.nationalarchives.gov.uk>) and found the document is available and releasable to the public.

Access to UK public records is governed by statute, namely the Public Records Act, 1958, and the Public Records Act, 1967.

The document has been released under the 30 year rule.

(The vast majority of records selected for permanent preservation are made available to the public when they are 30 years old. This is commonly referred to as the 30 year rule and was established by the Public Records Act of 1967).

**This document may be treated as UNLIMITED.**