

UNCLASSIFIED

AD 4 4 5 2 3 6

DEFENSE DOCUMENTATION CENTER

FOR

SCIENTIFIC AND TECHNICAL INFORMATION

CAMERON STATION, ALEXANDRIA, VIRGINIA



UNCLASSIFIED

NOTICE: When government or other drawings, specifications or other data are used for any purpose other than in connection with a definitely related government procurement operation, the U. S. Government thereby incurs no responsibility, nor any obligation whatsoever; and the fact that the Government may have formulated, furnished, or in any way supplied the said drawings, specifications, or other data is not to be regarded by implication or otherwise as in any manner licensing the holder or any other person or corporation, or conveying any rights or permission to manufacture, use or sell any patented invention that may in any way be related thereto.

445236

CALL BY DDC

AS AD NO. _____

Reprinted from

PHYTOCHEMISTRY

Vol. 3, No. 4

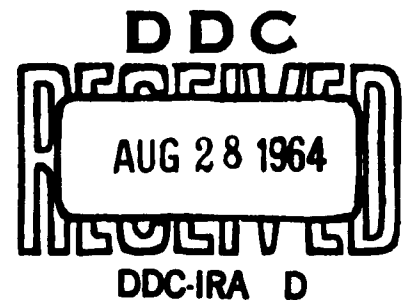

PERGAMON PRESS

OXFORD · LONDON · NEW YORK · PARIS

THE BIOSYNTHESIS OF HYDROXYBENZOIC ACIDS IN HIGHER PLANTS*

SAID Z. EL-BASYOUNI, D. CHEN, R. K. IBRAHIM, A. C. NEISH and G. H. N. TOWERS

Atlantic Regional Laboratory, National Research Council of Canada, Halifax, Nova Scotia

(Received 17 December 1963)

Abstract—Radioactive *p*-hydroxybenzoic, vanillic and syringic acids were shown to be synthesized in a variety of plants from the corresponding hydroxycinnamic acids labelled in the β -position. Decarboxylation of the hydroxybenzoic acids indicated that nearly all the activity was contained in the carboxyl carbons. In addition to the formation of C₆-C₁ acids by removal of a 2-carbon fragment from C₆-C₃ acids, some species were capable of O-methylating protocatechuic to vanillic acid or hydroxylating it to yield gallic acid. Demethoxylation of sinapic and dehydroxylation of caffeic acid occurred in some species. *Ortho* hydroxybenzoic acids were shown to arise from phenylalanine and cinnamic acid.

INTRODUCTION

ESTERS or glycosides of a variety of substituted benzoic acids occur in all higher plants,¹⁻⁵ some species being particularly rich in these compounds. *Gaultheria procumbens*, for example, yields *p*-hydroxybenzoic, vanillic, syringic, protocatechuic, salicylic, gentisic and *o*-pyrocatechuic(2,3-dihydroxybenzoic) acids on alkaline hydrolysis of aqueous or ethanolic extracts.⁶ Although Geissman and Hinreiner,⁷ in 1952, suggested that compounds of the C₆-C₁ class, in higher plants, arise by degradation of phenylpropanoid compounds this possibility has been examined only recently. Thus Gross and Schütte⁸ showed that the benzoic acid moiety of cocaine was radioactive after the administration of phenylalanine- β -¹⁴C to *Erythroxylon novogranatense*, and Grisebach and Vollmer⁹ have demonstrated that the radioactivity of salicylic acid, isolated from *Gaultheria procumbens* supplied with cinnamic acid- β -¹⁴C, was confined to the carboxyl carbon.

The biogenesis of the ubiquitous *para* hydroxylated benzoic acids, *p*-hydroxybenzoic, protocatechuic, vanillic, gallic and syringic acids, has received little attention. An enzyme, catalysing the synthesis of protocatechuic acid from 5-dehydroshikimic acid, is known in *Neurospora*¹⁰ and the latter compound has been shown to be a precursor of gallic acid in *Phycomyces blakesleeanus*.¹¹ Both protocatechuic and *o*-pyrocatechuic acids are believed to be formed at some pre-aromatic stage in the synthesis of the aromatic ring in *Aerobacter*

* Contribution from the Atlantic Regional Laboratory, National Research Council of Canada, Halifax, Nova Scotia. N.R.C. No. 7928.

¹ I. A. PEARL, D. L. BEYER and D. LASKOWSKI, *Tuppi* **42**, 319 (1959).

² I. A. PEARL, D. L. BEYER, D. LASKOWSKI and D. WHITNEY, *Tuppi* **43**, 756 (1960).

³ L. A. GRIFFITHS, *J. Exp. Bot.* **10**, 437 (1959).

⁴ M. TOMASZEWSKI, *Bul. Acad. polon. Sci., Ser. Sci. biol.* **8**, 61 (1960).

⁵ R. K. IBRAHIM, G. H. N. TOWERS and R. D. GIBBS, *J. Linn. Soc.* **58**, 223 (1962).

⁶ R. K. IBRAHIM and G. H. N. TOWERS, *Arch. Biochem. Biophys.* **87**, 125 (1960).

⁷ T. A. GEISSMAN and E. HINREINER, *Bot. Rev.* **18**, 165 (1952).

⁸ D. GROSS and H. R. SCHÜTTE, *Arch. Pharm.* **296**, 1 (1963).

⁹ H. GRISEBACH and K. O. VOLLMER, *Z. Naturforsch.* **18b**, 753 (1963).

¹⁰ S. R. GROSS, *J. Biol. Chem.* **233**, 1146 (1958).

¹¹ E. HASLAM, R. D. HAWORTH and P. F. KNOWLES, *J. Chem. Soc.* 1854 (1961).

aerogenes.¹² That gallic acid is derived from a non-aromatic precursor in higher plants is indicated by the fact that glucose-¹⁴C was found to be a far better precursor than phenylalanine-¹⁴C in *Geranium pyrenaicum*.¹³

RESULTS AND DISCUSSION

The hypothesis of Geissman and Hinreiner that compounds of the C₆-C₁ class in higher plants can be formed by removal of a two-carbon fragment from the three-carbon side-chain of phenylpropanoid compounds has been verified in the present study.

When phenylalanine-¹⁴C or cinnamic acid-¹⁴C was infiltrated into leaf segments of several species the types of phenolic acids formed were found to be characteristic of the species (Table 1). In *Oryza sativa* L. *p*-coumaric and ferulic acids were formed from phenylalanine.

TABLE 1. FORMATION OF RADIOACTIVE PHENOLIC ACIDS IN LEAF DISKS OF VARIOUS PLANTS FROM ¹⁴C-LABELLED PHENYLALANINE OR CINNAMIC ACID

Phenolic acid	% Distribution of radioactivity in acids formed from					
	L-Phenylalanine-U- ¹⁴ C			Cinnamic acid-β- ¹⁴ C		
	<i>Oryza sativa</i> L.	<i>Gaultheria procumbens</i> *	<i>Primula acaulis</i>	<i>Gaultheria procumbens</i> †	<i>Hydrangea macrophylla</i>	<i>Teucrium lusitanicum</i>
Salicylic	0	0	30	1	0	0
<i>o</i> -Pyrocatechuic	0	1	20	1	0	0
Gentisic	0	1	20	3	2	0
<i>p</i> -Hydroxybenzoic	4	0	0	0	0	0
Protocatechuic	0	0	0	3	3	0
Vanillic	4	0	0	1	0	1
<i>o</i> -Coumaric	0	0	12	36	0	0
<i>p</i> -Coumaric	20	32	2	23	7	38
Caffeic	0	0	0	1	3	26
Ferulic	54	0	0	0	2	5
Unidentified	18	66	16	31	83‡	30

* Mature leaves.

† Young leaves.

‡ Ten per cent of the activity was in umbelliferone and 7-hydroxy-8-methoxycoumarin.

Syringic and sinapic acids showed no activity in these experiments.

Radioactive compounds administered for 24 hr in light.

Gaultheria procumbens formed mainly *p*-coumaric acid whereas in *Primula acaulis* *o*-coumaric acid and *ortho* hydroxylated benzoic acids were synthesized. The main acids formed from cinnamic acid were *p*-coumaric and *o*-coumaric in *Gaultheria*, *p*-coumaric and caffeic acids in *Teucrium lusitanicum* (Fig. 1) and small amounts of *p*-coumaric, caffeic and ferulic acids in *Hydrangea macrophylla* (Table 1).

The formation of a number of *ortho* hydroxylated acids in the different species investigated suggests the sequence: cinnamic acid → *o*-coumaric acid → salicylic acid → gentisic and *o*-pyrocatechuic acids. This scheme is similar to the one put forward by Grisebach and Vollmer.⁹ Salicylic acid has been shown to be hydroxylated in the 3- or 5-position when introduced into plants¹⁴ giving rise to *o*-pyrocatechuic and gentisic acids respectively.

¹² A. J. PITTARD, F. GIBSON and C. H. DOY, *Biochim. Biophys. Acta* **57**, 290 (1962).

¹³ E. E. CONN and T. SWAIN, *Chem. and Ind.* 592 (1961).

¹⁴ R. K. IBRAHIM and G. H. N. TOWERS, *Nature* **184**, 1803 (1959).



FIG. 1. RADIOAUTOGRAPH OF THE CHROMATOGRAPHED PHENOLIC ACID FRACTIONS OF *Teucrium hastaticum* LIAI DISKS ADMINISTERED CINNAMIC ACID- β - 14 C.

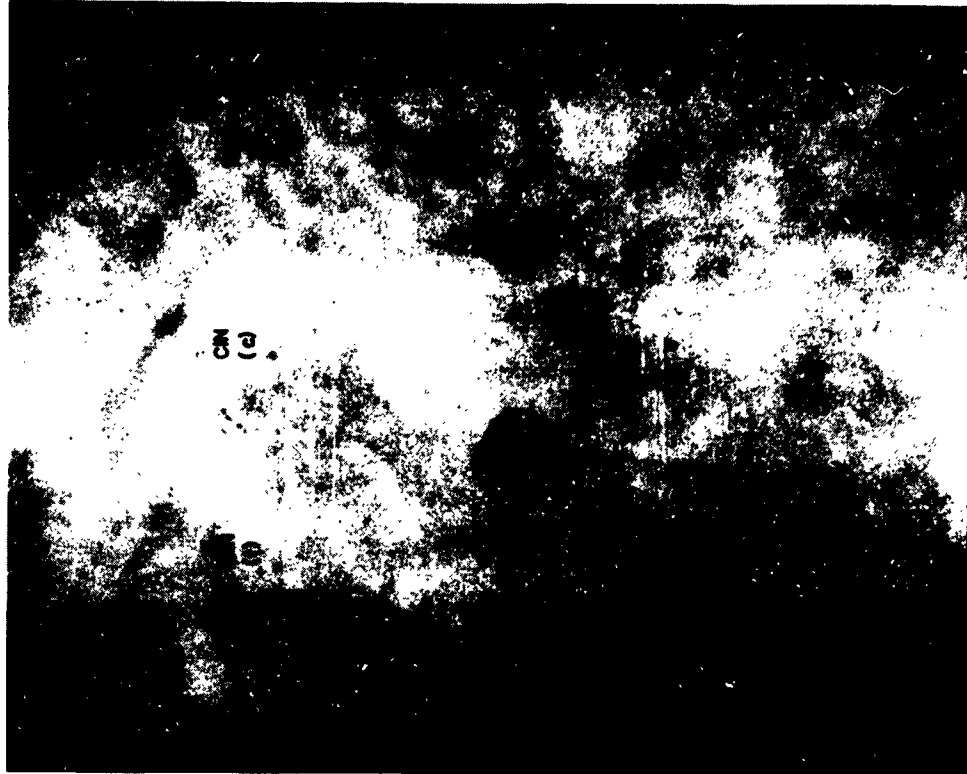

FIG. 2. RADIOAUTOGRAPH OF THE CHROMATOGRAPHED PHENOLIC ACID FRACTIONS OF *Maitantheum canadensis* LIAI DISKS ADMINISTERED *p*-COUMARIC ACID- β - 14 C.



FIG. 3. RADIOAUTOGRAPH OF THE CHROMATOGRAPHED PHENOLIC ACID FRACTIONS OF *Pelargonium hortorum* LEAF DISKS ADMINISTERED FERULIC ACID- β - 14 C.

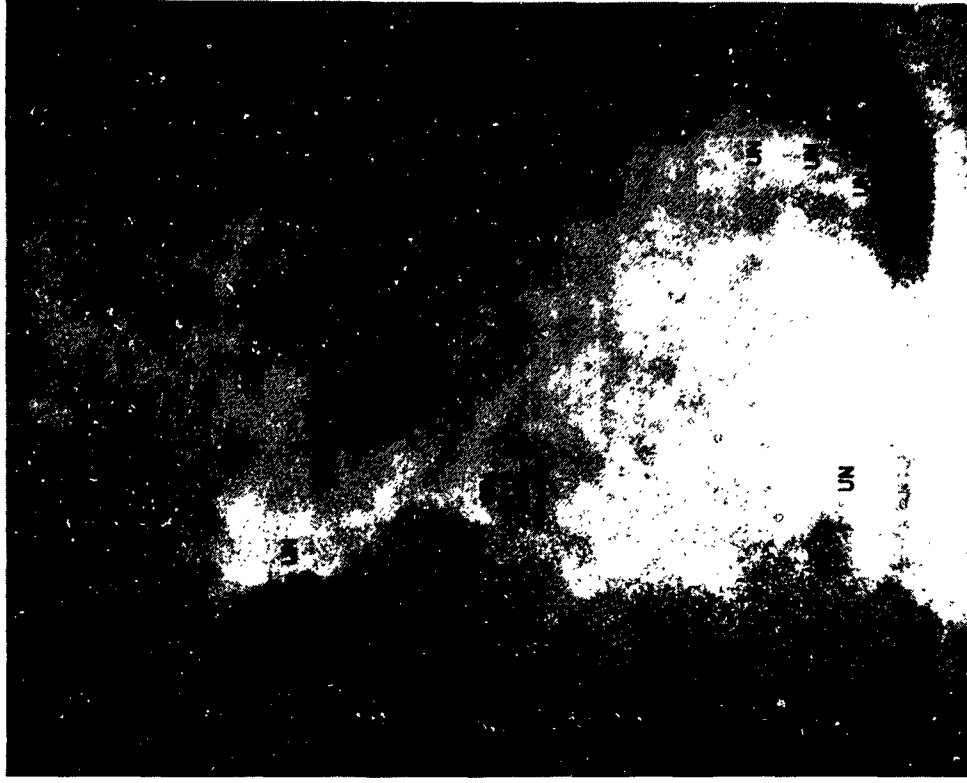

FIG. 4. RADIOAUTOGRAPH OF THE CHROMATOGRAPHED PHENOLIC ACID FRACTIONS OF *Oryza sativa* LEAF SEGMENTS ADMINISTERED SINAPIC ACID- β - 14 C.

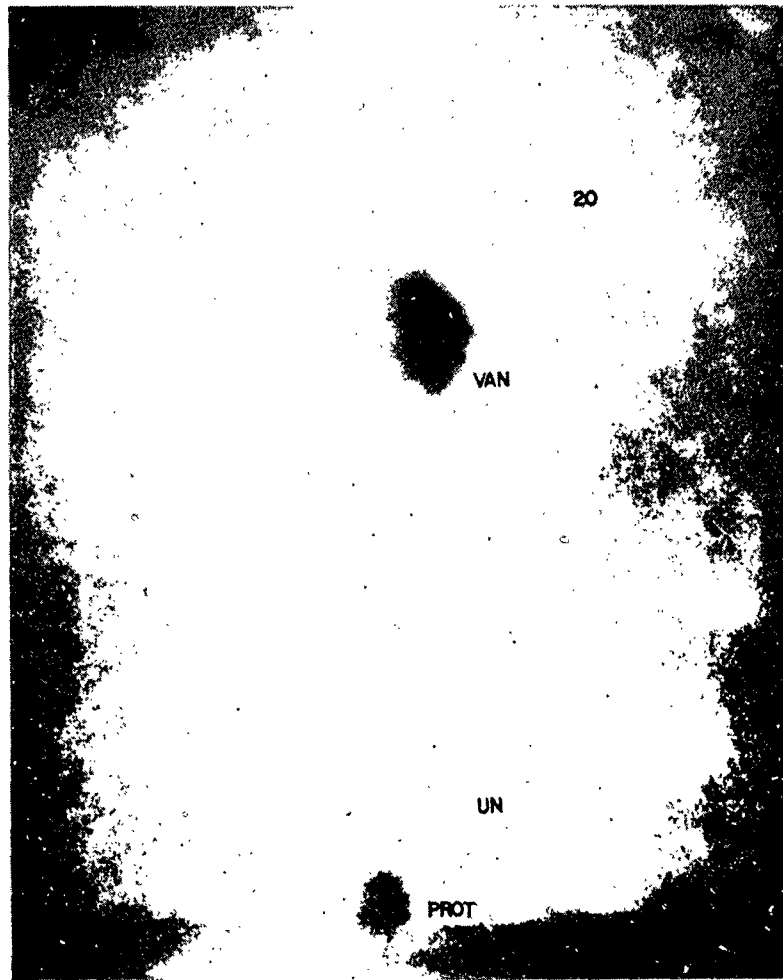

FIG. 5. RADIOAUTOGRAPH OF THE CHROMATOGRAPHED PHENOLIC ACID FRACTIONS OF *Hordeum vulgare* LEAF SEGMENTS ADMINISTERED PROTO-CATECHUIC ACID-CARBOXY¹⁴C.

TABLE 2. FORMATION OF RADIOACTIVE PHENOLIC ACIDS FROM ^{14}C -LABELLED HYDROXYCINNAMIC ACIDS IN LEAF DISKS OF VARIOUS PLANTS*

Phenolic acid	% Distribution of radioactivity in acids formed from															
	p -Coumaric- β - ^{14}C				Caffeic- β - ^{14}C				Ferulic- β - ^{14}C				Sinapic- β - ^{14}C			
	<i>Oryza sativa</i> L.	<i>Hordeum vulgare</i>	<i>Maianthemum canadensis</i>	<i>Pelarogonium hortorum</i>	<i>Oryza sativa</i> L.	<i>Maianthemum canadensis</i>	<i>Pelarogonium hortorum</i>	<i>Oryza sativa</i> L.	<i>Hordeum vulgare</i>	<i>Maianthemum canadensis</i>	<i>Pelarogonium hortorum</i>	<i>Oryza sativa</i> L.	<i>Hordeum vulgare</i>	<i>Pelarogonium hortorum</i>	<i>Oryza sativa</i> L.	<i>Hordeum vulgare</i>
<i>p</i> -Hydroxybenzoic	16	13	8	2	0	0	0	0	0	0	0	0	0	0	0	0
Protocatechuic	0	0	0	0	11	0	0	0	0	0	0	0	0	0	0	0
Vanillic	2	0	0	0	4	0	0	14	23	0	13	0	0	0	0	0
Syringic	0	0	0	0	0	0	0	0	0	0	0	0	0	6	4	0
<i>p</i> -Coumaric	21	44	72	89	0	0	0	0	0	0	0	0	0	0	0	0
Caffeic	0	0	0	0	10	20	100	0	0	0	0	0	0	0	0	0
Ferulic	4	4	0	0	61	0	0	49	38	0	64	0	0	0	0	2
Sinapic	0	0	0	0	0	0	0	0	0	0	0	0	0	5	4	0
Unidentified	57	39	20	9	14	80	0	37	39	0	23	0	0	89	90	0

* Radioactive compounds administered for 24 hr in dark.

Cinnamic acid derivatives were metabolized by several species to produce benzoic acid derivatives as well as unidentified compounds (Table 2). Thus *p*-coumaric acid was converted to *p*-hydroxybenzoic acid in *Oryza*, *Hordeum vulgare*, *Maianthemum canadensis* (Fig. 2) and *Pelargonium hortorum*. Ferulic acid gave rise to vanillic acid in *Oryza*, *Hordeum* and *Pelargonium* (Fig. 3) and syringic acid was formed from sinapic acid in *Oryza* (Fig. 4) and *Hordeum*. Caffeic acid was converted to protocatechuic acid by *Oryza* leaf segments although O-methylation to ferulic acid was the main reaction.

There is probably another route leading to the hydroxybenzoic acids, i.e., hydroxylation and O-methylation of C₆-C₁ precursors. For example, carboxyl-labelled benzoic acid was converted to salicylic, *o*-pyrocatechuic, gentisic and *p*-hydroxybenzoic acids in leaf disks of *Gaultheria* and *Primula* (Table 3). The reduced ability of older tissues of *Gaultheria* and

TABLE 3. FORMATION OF RADIOACTIVE PHENOLIC ACIDS IN LEAF DISKS OF PLANT ADMINISTERED BENZOIC ACID CARBOXY ¹⁴C FOR 24 hr IN DARK

Phenolic acid*	Distribution of radioactivity (%)				
	<i>Gaultheria procumbens</i>			<i>Primula acaulis</i>	
	Young†	Mature‡	Old	Young†	Mature‡
Benzoic	36	80	62	60	80
Salicylic	27	5	0	17	6
<i>o</i> -Pyrocatechuic	13	2	0	7	3
Gentisic	3	5	1	2	3
<i>p</i> -Hydroxybenzoic	17	6	0	4	4
Unidentified	4	2	37	10	4

* No activity was found in protocatechuic, vanillic, or syringic acids in any of the experiments.

† Leaves 2-3 weeks old.

‡ Leaves about 6 weeks old.

Primula to hydroxylate benzoic acid in either the *ortho* or *para* position is noteworthy. In experiments, the results of which do not appear in tabular form, protocatechuic acid was shown to be synthesized from *p*-hydroxybenzoic acid-carboxy ¹⁴C although to only a very small extent (< 1% of phenolic acid extracts).

Experiments in which carboxyl-labelled protocatechuic acid was administered to five species showed some marked differences (Table 4). This compound was hydroxylated in *Pelargonium* to give gallic acid whereas it was O-methylated in *Maianthemum*, *Hordeum* (Fig. 5) and *Oryza* to give vanillic acid. In *Gaultheria* there was little change. The usefulness in comparing a number of species is evident.

Syringic acid-¹⁴C was not detected on radioautographs of chromatograms of four species (leaf segments) administered vanillic acid-carboxy ¹⁴C. In fact no radioactive phenolic acids other than vanillic acid itself were detected in these experiments.

When ¹⁴C-labelled phenylalanine and the common natural phenylpropanoid acids were administered to wheat shoots they were converted to *p*-hydroxybenzoic, vanillic and syringic acids. This conversion must occur by a fairly direct route judging from the low dilution of isotopic carbon (Table 5) and retention of the [¹⁴C] in the same position relative

TABLE 4. FORMATION OF RADIOACTIVE PHENOLIC ACIDS IN LEAF DISKS OF VARIOUS PLANTS ADMINISTERED PROTOCATECHUIC ACID-CARBOXY ^{14}C

Phenolic acid*	Distribution of radioactivity (%)								
	<i>Gaultheria procumbens</i>		<i>Pelargonium hortorum</i>		<i>Maianthemum canadensis</i>	<i>Hordeum vulgare</i>	<i>Oryza sativa</i> L.		
	Light 24 hr	Dark 24 hr	Light 24 hr	Dark 24 hr	Dark 24 hr	Dark 24 hr	Light 24 hr	Dark 24 hr	Dark 96 hr
<i>p</i> -Hydroxybenzoic	0	0	0	0	0	0	0	0	0
Protocatechuic	98	97	50	60	54	21	82	85	42
Vanillic	0	0	0	0	22	68	17	14	36
Gallic	0	0	47	38	0	0	0	0	0
Unidentified	2	3	3	2	24	11	1	1	22

* Syringic acid was not labelled in these experiments.

to the ring (Table 6). In these experiments with *Triticum* sinapic acid- ^{14}C was synthesized from radioactive *p*-coumaric or ferulic acid. The conversion of ferulic to sinapic acid in *Salvia* has been shown by McCalla and Neish¹⁵ and in *Triticum* by Higuchi and Brown.¹⁶ Failure to obtain syringyl compounds in the experiments discussed in Tables 1-4 may be due to the fact that leaf segments were used. With *Triticum*, leafy shoots were administered radioactive compounds and it is possible that synthesis of syringyl compounds is more pronounced in stem tissues.

TABLE 5. FORMATION OF HYDROXYBENZOIC ACIDS IN WHEAT SHOOTS FROM ADMINISTERED PHENYLPROPANOIC COMPOUNDS

Radioactive hydroxybenzoic acid formed	Radioactive phenylpropanoid compound administered					
	L-Phenylalanine-U- ^{14}C 165 $\mu\text{C}/\text{mM}$	Cinnamic acid- β - ^{14}C 92 $\mu\text{C}/\text{mM}$	<i>p</i> -Coumaric acid- β - ^{14}C 32 $\mu\text{C}/\text{mM}$	Caffeic acid- β - ^{14}C 40 $\mu\text{C}/\text{mM}$	Ferulic acid- β - ^{14}C 87 $\mu\text{C}/\text{mM}$	Sinapic acid- β - ^{14}C 64 $\mu\text{C}/\text{mM}$
<i>p</i> -Hydroxybenzoic						
Total amount (μM)	0.30	0.26	0.37	0.35	N.D.	0.44
Specific activity ($\mu\text{C}/\text{mM}$)	4.6	26	26.8	2.8	N.D.	2.8
Dilution value	36	3.6	1.2	14	N.D.	23
Vanillic						
Total amount (μM)	0.14	0.28	0.18	0.21	0.21	N.D.
Specific activity ($\mu\text{C}/\text{mM}$)	18.7	46.3	13	9.0	48	N.D.
Dilution value	8.8	2.0	2.4	4.4	1.8	N.D.
Syringic						
Total amount (μM)	0.19	0.13	0.17	0.19	0.13	0.33
Specific activity ($\mu\text{C}/\text{mM}$)	7.4	38.8	4.0	8.1	13.8	61
Dilution value	22	2.4	7.9	4.9	6.3	1.0

N.D. Not determined.

Radioactive compounds administered for 24 hr in light.

¹⁵ D. R. McCALLA and A. C. NEISH, *Canad. J. Biochem. Physiol.* **37**, 537 (1959).

¹⁶ T. HIGUCHI and S. A. BROWN, *Canad. J. Biochem. Physiol.* **41**, 613 (1963).

Demethoxylation of sinapic acid to produce ferulic and/or vanillic acids was achieved in *Hordeum*, *Oryza* and *Triticum* (see Tables 2 and 5). Similar results have been reported by others. Thus labelled coniferyl alcohol and coniferyl aldehyde have been obtained¹⁶ from *Triticum* administered sinapic acid-¹⁴C and radioactive vanilloyl methyl ketone has been isolated¹⁷ from spruce lignin after feeding ¹⁴C-labelled syringin. In our experiments not only was sinapic acid converted to vanillic acid but it was further demethoxylated in *Triticum* to yield *p*-hydroxybenzoic acid. The conversion of caffeic acid to *p*-hydroxybenzoic acid (see Table 5) suggests that dehydroxylation of the former compound can also be effected in *Triticum*. As it was not determined whether the activity of *p*-hydroxybenzoic acid in this case was confined to the carboxyl carbon this assumption may not be valid.

TABLE 6. DECARBOXYLATION OF RADIOACTIVE HYDROXYBENZOIC ACIDS ISOLATED AFTER THE ADMINISTRATION OF HYDROXYCINNAMIC ACIDS TO *Triticum vulgare*

Compound administered	Compound isolated (B)	Sp. act. of (B) (m μ c/mM)	Sp. act. of BaCO ₃ from decarboxylation of (B) (m μ c/mM)
<i>p</i> -Coumaric acid- β - ¹⁴ C	<i>p</i> -Hydroxybenzoic acid	187	161
Ferulic acid- β - ¹⁴ C	Vanillic acid	224	219
Sinapic acid- β - ¹⁴ C	Syringic acid	279	277

A problem which was not investigated in any detail concerns the actual form in which the phenolic acids undergo β -oxidation, hydroxylation or methylation. Chromatograms and radioautographs of non-hydrolysed extracts, not shown here, indicated that the bulk of the radioactivity was in conjugates of the phenolic acids. There is evidence that chlorogenic acid synthesis in the potato tuber occurs by oxidation of cinnamic acid only after conversion to the quinoyl ester.¹⁸ Grisebach and Vollmer⁹ suggest that the formation of salicylic acid from cinnamic acid involves coenzyme A esters. It should be borne in mind, however, that the hydroxylation of cinnamic acid to *p*-coumaric acid in the fungus, *Polystictus versicolor*, has been considered to be a direct reaction, without the formation of an active intermediate.¹⁹

Phenolic acids such as caffeic acid are methylated in animals by methionine in the presence of catechol-O-methyl transferase,²⁰ the methyl donor being S-adenosyl-L-methionine. A similar enzyme has been detected recently in plants.²¹

In summary, it appears that at least two routes are available for the production of hydroxybenzoic acids in higher plants, one by the β -oxidation of cinnamic acid and its hydroxylated and O-methylated derivatives and the other by hydroxylation and O-methylation of the simpler members of the C₆-C₁ series. A suggested scheme for the interrelationships of the C₆-C₃ and C₆-C₁ acids in higher plants is shown in Fig. 6. In view of what is known of aromatic biosynthesis in micro-organisms it is possible that other routes exist such as the formation of protocatechuic and gallic acids from 5-dehydroshikimic acid.¹³

¹⁷ K. KRATZL, *Tappi*, **43**, 650 (1960).

¹⁸ C. C. LEVY and M. ZUCKER, *J. Biol. Chem.* **235**, 2418 (1960).

¹⁹ V. C. FARMER, M. E. K. HENDERSON and J. D. RUSSELL, *Biochem. Biophys. Acta* **35**, 202 (1959).

²⁰ J. PELLERIN and A. D'ORIO, *Canad. J. Biochem. Physiol.* **36**, 491 (1958).

²¹ B. J. FINKLE and M. S. MASRI, Abstracts, Third Annual Meeting Plant Phenolics Group of North America, Toronto, Canada, September, 1963.

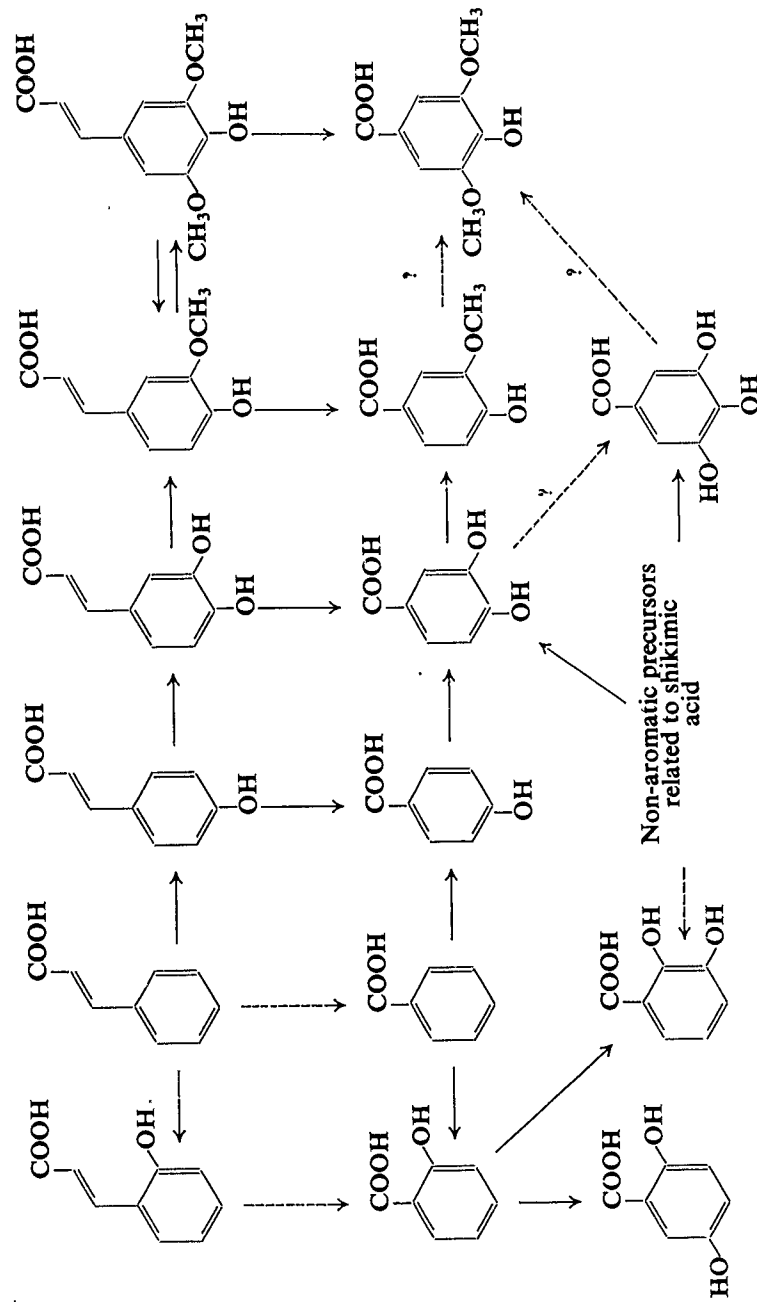

FIG. 6. INTERRELATIONS OF ACIDS OF THE CINNAMIC AND BENZOIC SERIES IN HIGHER PLANTS. DOTTED ARROWS INDICATE POSSIBLE ROUTES.

EXPERIMENTAL

Plant Material

Gaultheria procumbens, *Hydrangea macrophylla*, *Primula acaulis* and *Pelargonium hortorum* were greenhouse grown plants. *Maianthemum canadensis* was collected in the vicinity of Halifax, N.S. Seeds of rice (*Oryza sativa*, L. Taichung No. 65) were obtained from the Taiwan Agricultural Research Institute, Taiwan, China. Seeds of barley (*Hordeum vulgare*, var. Montcalm) and of wheat (*Triticum vulgare* var. Kharkov) were obtained from Professor H. R. Klinck, Macdonald College. They were germinated according to the method described by Neish²² and shoots of two-week-old seedlings were used.

¹⁴C-Labelled Compounds

L-Phenylalanine-U-¹⁴C, benzoic acid-carboxy-¹⁴C and cinnamic acid-β-¹⁴C were purchased from Merck Radiochemical Laboratory, Montreal. The preparation of *p*-hydroxybenzoic acid-carboxy ¹⁴C, protocatechuic acid-carboxy ¹⁴C, vanillic acid-carboxy ¹⁴C, *p*-coumaric acid-β-¹⁴C, caffeic acid-β-¹⁴C, ferulic acid-β-¹⁴C and sinapic acid-β-¹⁴C have been described previously.^{23,24}

Methods

In each treatment 50–60 leaf disks, 1.2 cm in diameter obtained with a Ganong leaf punch, or, in the case of cereals, 1-in. leaf segments, were infiltrated under vacuum with tap water, blotted and placed in a Petri dish containing the radioactive solution (2 μc). The covered Petri dish was placed under a bank of fluorescent lights or in the dark for 24 hr.

In experiments with *Triticum* cut shoots of seedlings were held in small vials containing the radioactive solutions and allowed to stand under a bank of fluorescent lights (1500 f.c.) for 24 hr. During this period, the solutions were usually completely absorbed and water was added from time to time to prevent desiccation of the cuttings. The dose varied from 15 to 20 μM/g dry weight representing a total activity of 5 μc in each treatment.

After incubation the plant materials were killed in boiling 95% ethanol and analysed for radioactive phenolic acids obtained after acid or alkaline hydrolysis of the ethanol soluble fraction. Chromatographic methods and the preparation of radioautographs have been previously described.^{6,14} The method used by Neish²² for the determination of *p*-coumaric acid was adopted for the determinations of the hydroxybenzoic acids. Measurements were made with a Beckman DU spectrophotometer at 282 mμ for *p*-hydroxybenzoic acid, 298.5 mμ for vanillic acid and 302 mμ for syringic acid.

Radioactivity measurements were made with a Tri-Carb Model 314A Liquid Scintillation Spectrometer.

Radioactive hydroxybenzoic acids were isolated by chromatography, diluted with inactive carrier and after repeated crystallizations, decarboxylated using quinoline and copper chromite.²⁵ Radioactive CO₂ was determined as BaCO₃.

²² A. C. NEISH, *Phytochemistry* **1**, 1 (1961).

²³ S. A. BROWN and A. C. NEISH, *Canad. J. Biochem. Physiol.* **33**, 948 (1955).

²⁴ S. A. BROWN and A. C. NEISH, *Canad. J. Biochem. Physiol.* **34**, 769 (1956).

²⁵ P. RUGGLI and F. BRANDT, *Helv. Chim. Acta* **26**, 274 (1944).