

UNCLASSIFIED

AD. 4 4 2 6 2 7

DEFENSE DOCUMENTATION CENTER

FOR

SCIENTIFIC AND TECHNICAL INFORMATION

CAMERON STATION ALEXANDRIA, VIRGINIA



UNCLASSIFIED

NOTICE: When government or other drawings, specifications or other data are used for any purpose other than in connection with a definitely related government procurement operation, the U. S. Government thereby incurs no responsibility, nor any obligation whatsoever; and the fact that the Government may have formulated, furnished, or in any way supplied the said drawings, specifications, or other data is not to be regarded by implication or otherwise as in any manner licensing the holder or any other person or corporation, or conveying any rights or permission to manufacture, use or sell any patented invention that may in any way be related thereto.

Document Number
TRACOR 64-228-U

CATALOGED BY DDC
AS AD No. 442627

QUARTERLY STATUS REPORT NO. 5

1 January - 31 March 1964

ELECTROCHEMICAL STUDIES IN THE
SYNTHESIS OF N-F COMPOUNDS

TRACOR, Inc.

Contract No. Nonr-4054(00)
Research Project No. RR001-06-02
ARPA Order No. 399, Program Code No. 2910

July 9, 1964

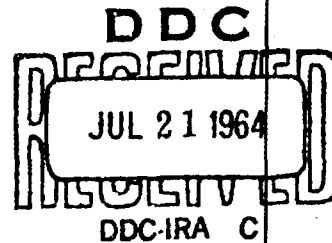

1701 GUADALUPE ST.

AUSTIN, TEXAS 78701

GR6-6601

TRACOR

INC.

442627

TRACOR, INC. 1701 Guadalupe St. Austin 1, Texas

QUARTERLY STATUS REPORT NO. 5

1 January - 31 March 1964

ELECTROCHEMICAL STUDIES IN THE SYNTHESIS OF N-F COMPOUNDS

TRACOR, Inc.

Contract No. N001-4054(00)

Research Project No. RR001-06-02

ARPA Order No. 399, Program Code No. 2910

July 9, 1964

Prepared by:

Larry G. Spears
Larry D. Fiel
Wallace E. Harrell, Jr.
Gerhard M. Schmid

Approved by:

Earl S. Snavely, Jr.
Assistant Director of
Chemical Research

Reproduction in whole or in part is permitted for any purpose of the United States Government.

TABLE OF CONTENTS

	<u>Page</u>
LIST OF ILLUSTRATIONS	iii
ABSTRACT	iv
I. INTRODUCTION	1
II. EXPERIMENT . APPARATUS	2
III. WORKING ELECTRODES	12
A. Antimony	13
B. Bismuth	13
C. Silver	13
D. Aluminum	13
E. Titanium	18
F. Cobalt	18
G. Iron	18
H. Copper	23
I. Monel	23
IV. DISCUSSION	33
V. FUTURE WORK	34
REFERENCES	35

Abstract

This report describes work which has been devoted to the development of a suitable working electrode for use in electrochemical fluorination studies in anhydrous HF (AHF).

Investigations of possible working electrodes have involved antimony, bismuth, silver, aluminum, titanium, cobalt, iron, and monel. Antimony, bismuth, and silver show a high anodic dissolution rate in AHF, while the other metals studied show passive behavior. Of the latter metals only monel formed a protective coating which permitted appreciable fluorine evolution to occur.

ELECTROCHEMICAL STUDIES IN THE SYNTHESIS OF N-F COMPOUNDS

I. INTRODUCTION

During the past quarter work has continued on the development of a corrosion resistant working electrode for use in the study of the electrochemical fluorination of NH_3 and N_2H_4 in AHF. A desirable working anode would exhibit a low anodic dissolution rate and have a low interfacial impedance.

It appears that of the metals studied thus far, monel comes closest to fulfilling the requirements for a working anode and will thus be used to study the electrochemical fluorination of NH_3 and N_2H_4 in future work. Additional electrodes (pyrolytic carbon, zirconium boride and molybdenum) will also be investigated in an effort to find a still better working electrode.

II. EXPERIMENTAL APPARATUS

Some improvements in the handling of AHF were made this quarter, mainly to increase the purity of HF in the conductance and electrolytic cells. (See Figure 1 for a general schematic diagram of the entire system now being used.)

The refrigerated HF pot was replaced by a monel pot (Figure 2) that does not require refrigeration but is instead operated by differential pressures as follows: The pot is first evacuated and then the HF is admitted from the tank into the pot where the desired volume is measured. Then 10 psi of nitrogen pressure is applied, and the valve leading to the HF trap is opened (slightly at first) allowing the HF to enter the first NaF trap. If necessary a small flow of nitrogen is used to aid this transfer.

Two HF traps were constructed, one from mild steel and the other from monel (Figure 3). Each has a capacity of approximately 400 ml of (liquid) HF. The traps are filled with NaF pellets (formed by heating NaHF_2 pellets). The distillation procedure from the #1 trap to the #2 trap to the conductance cell is the same as reported in Quarterly Status Report No. 4.

It has been found that the conductance of a certain volume of HF would change considerably with time in the Teflon TFE conductance cell, presumably due to water diffusing through the Teflon. Therefore, the conductance and storage cells were replaced by a single Kel-F cell (Figure 4). The latter was sealed using a Teflon gasket between lid and body of the cell and applying pressure to it by tightening the bolts connecting the two brass rings (Figure 5). This gave a tight seal up to 20 psi. The cell is cooled with crushed dry ice.

The nickel conductance electrodes and the nickel screen cathodes formed NiF_2 when in contact with HF for several days. They were replaced by platinum electrodes. Platinum conductance

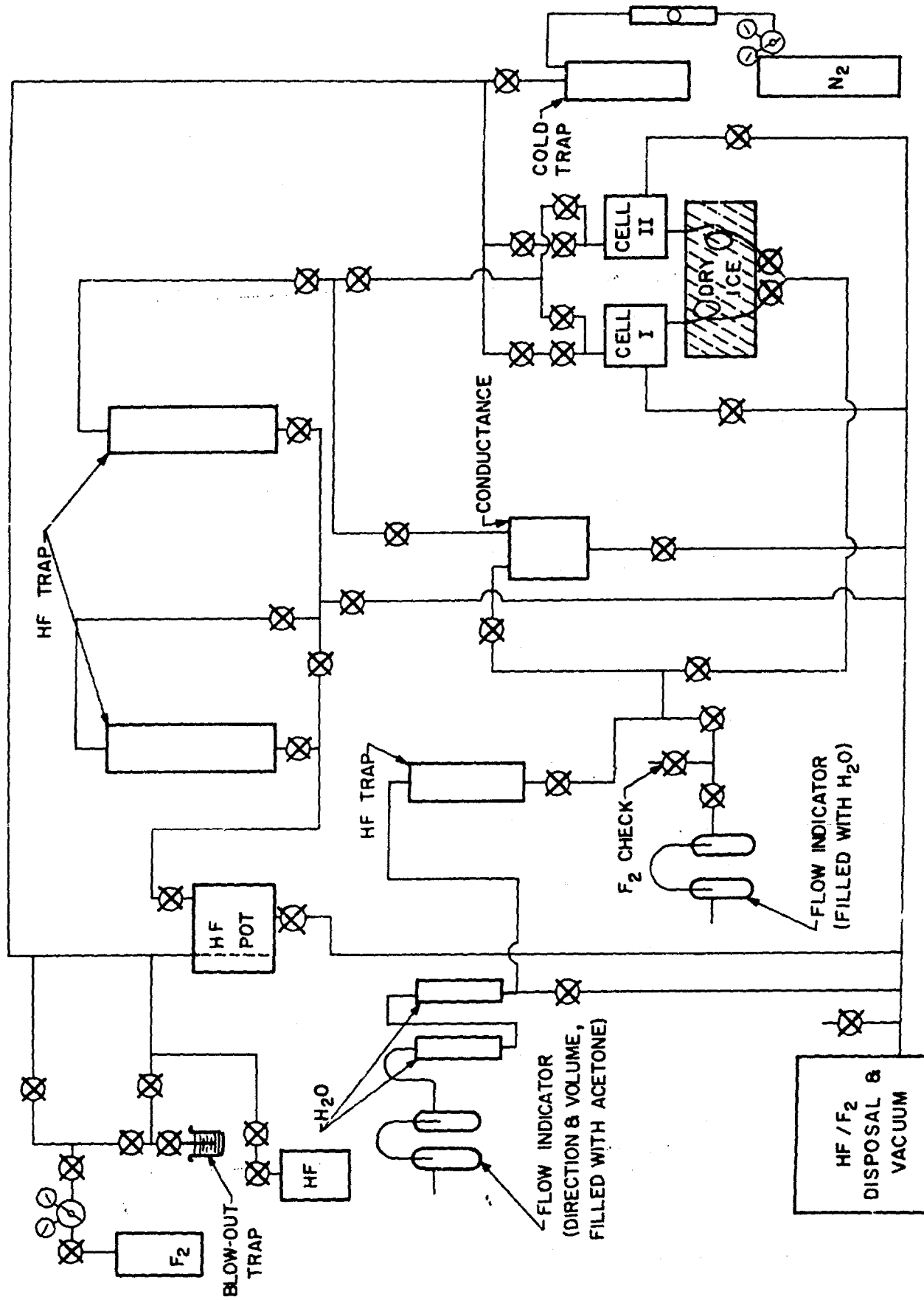

Fig. 1 - HF HANDLING SYSTEM

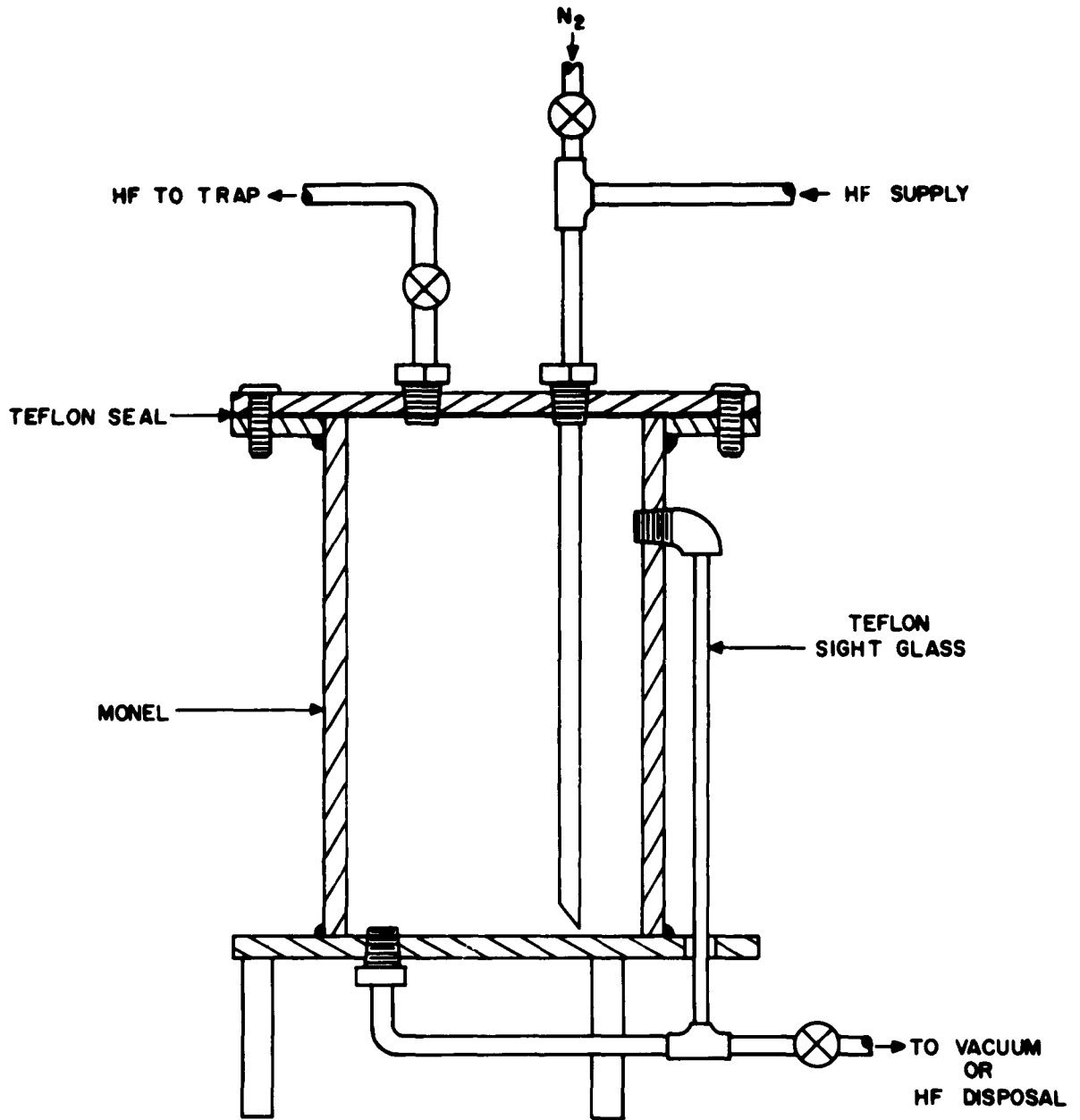

Fig. 2- HF MONEL POT

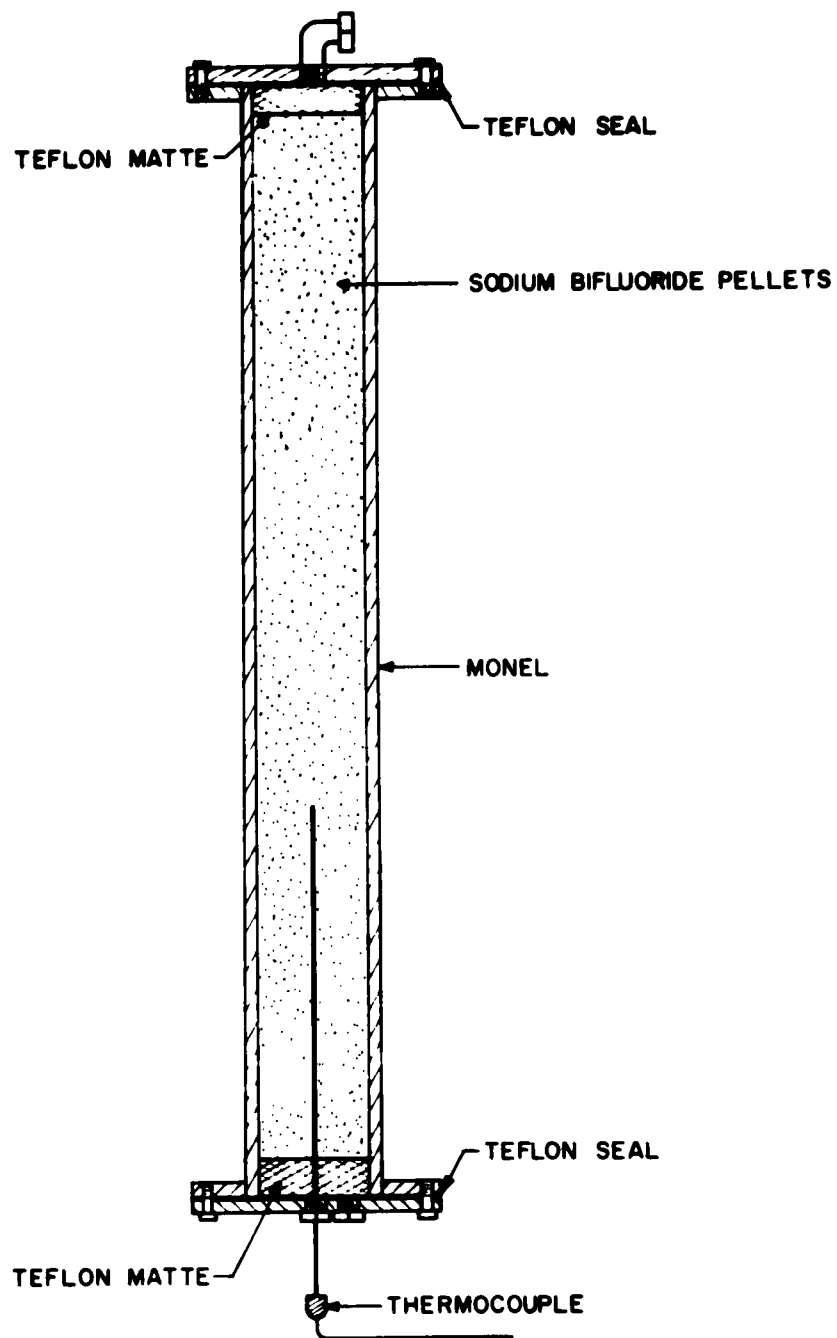

Fig. 3-MONEL HF TRAP

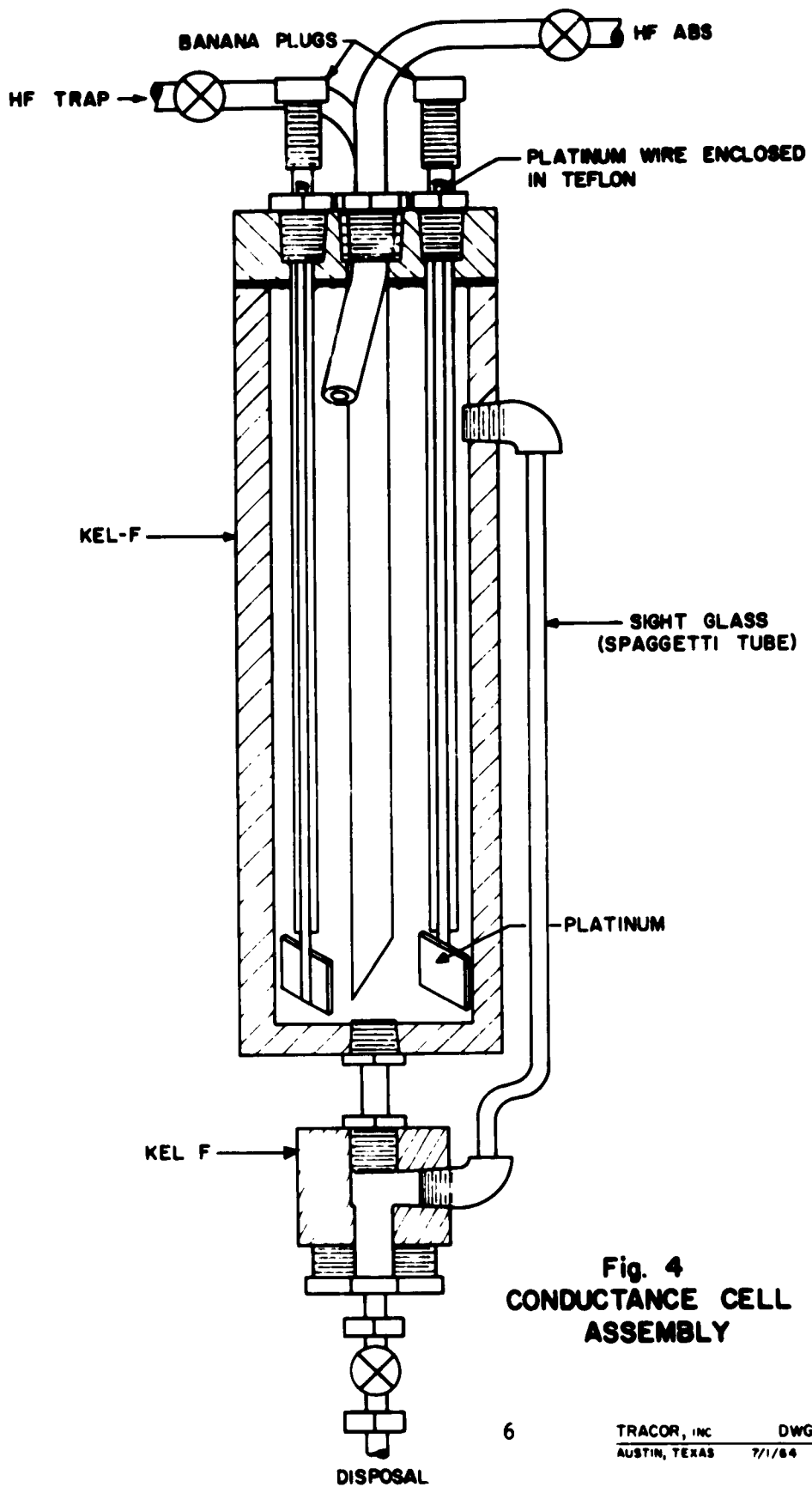

Fig. 4
 CONDUCTANCE CELL
 ASSEMBLY

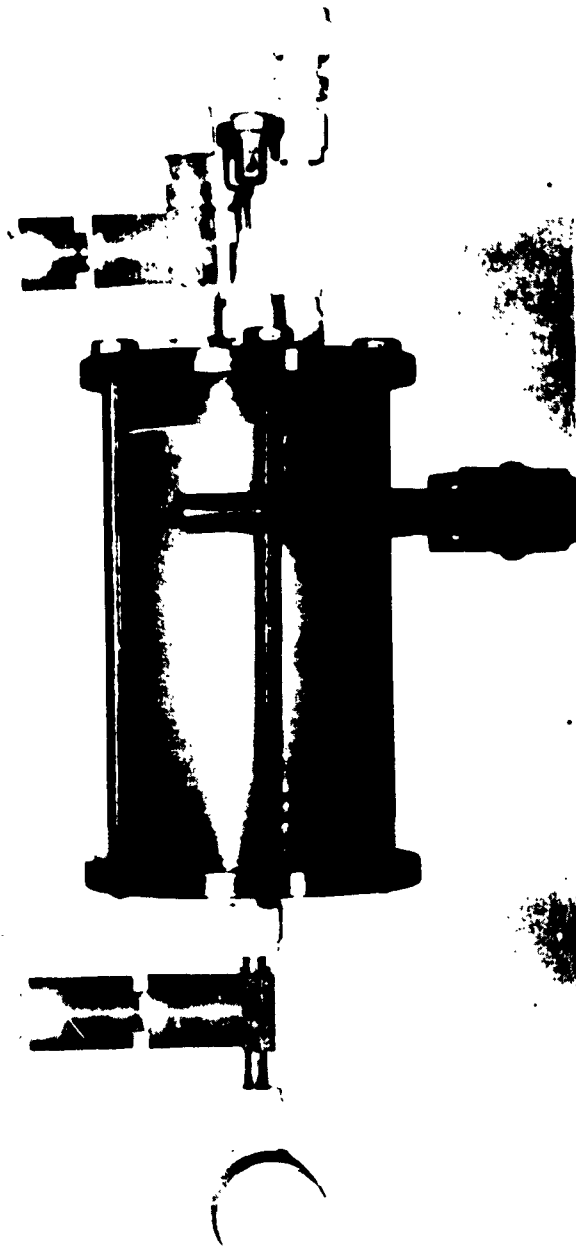

Fig. 5-KEL-F CONDUCTANCE CELL

electrodes were also placed in each electrolytic cell. So far no platinum fluoride has been noted to form.

The electrolytic cell condenser was replaced by a simpler and more efficient one. It consisted of one revolution of 3/8" coiled Teflon tubing surrounded with crushed dry ice (Figure 6). Thus each cell has its own condenser. A check on their efficiency showed that no measurable loss of HF occurred over a period of one week as compared to a loss of several milliliters per day with the old condenser.

A new type of low pressure valve made of Kel-F was designed and manufactured by TRACOR (Figure 7). These valves were installed between the #2 trap and the conductance and electrolytic cells. The valves are leak free at the pressures employed and do not introduce any contaminants into the system.

A fluorination system was added to the HF system during this quarter in order to passivate that part of the equipment which comes in contact with the HF. This passivation process proved to be very effective as indicated by the increase in the resistance of the HF obtained upon distillation after passivation. The procedure for passivation is as follows: (1) Dry nitrogen is run through the system for one hour. (2) Fluorine is then allowed to displace the nitrogen slowly until the fluorine causes the ignition of a piece of tissue paper being held at the opened tube on the N₂/F₂ bubbler (Figure 8). (3) The valve before the bubbler is then closed and a pressure of 7 psig of fluorine is used to passivate the system for 10 minutes. (4) The valve leading to the F₂ disposal system is then opened slightly, and the system is allowed to come to atmospheric pressure before purging it with dry nitrogen for one hour. (5) All valves are then closed until the system is needed.

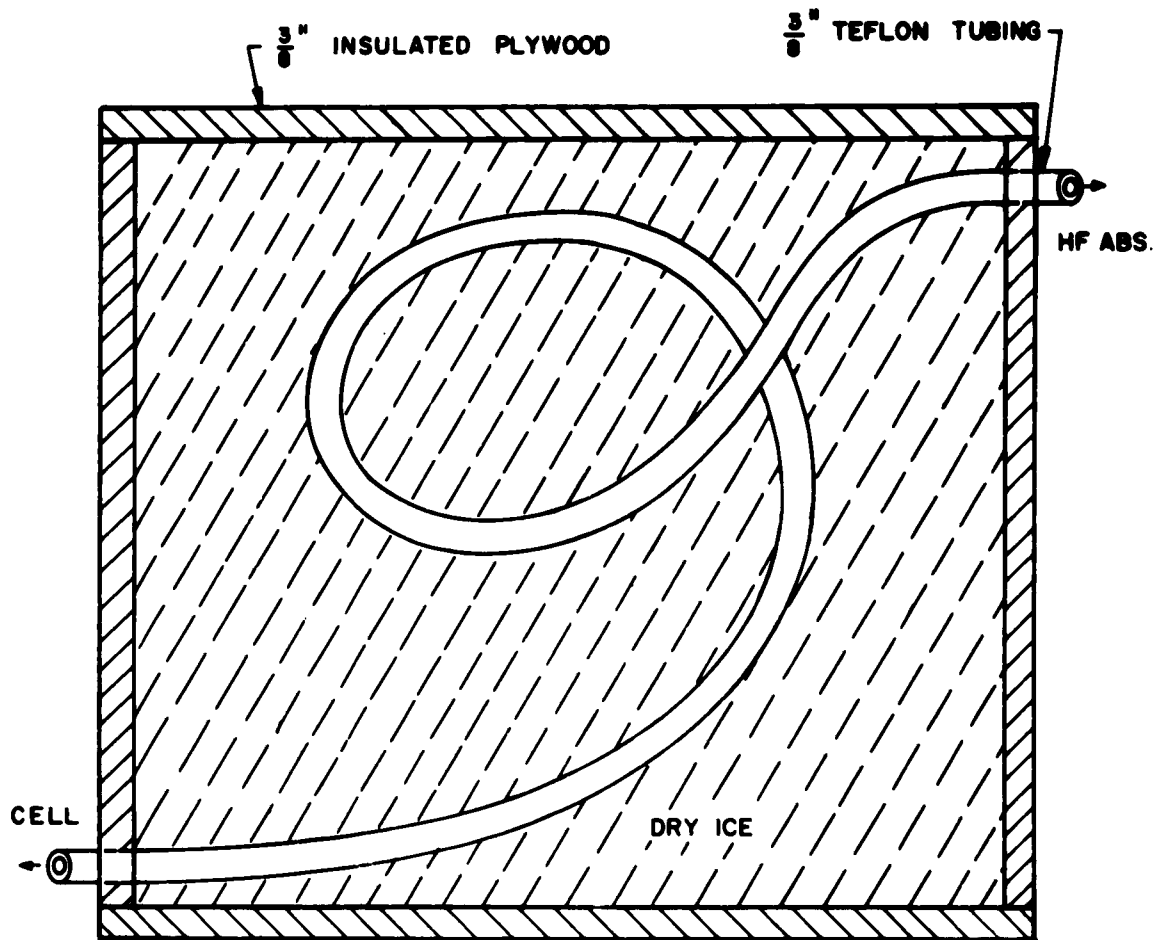

Fig. 6 -ELECTROLYTIC CELL CONDENSER

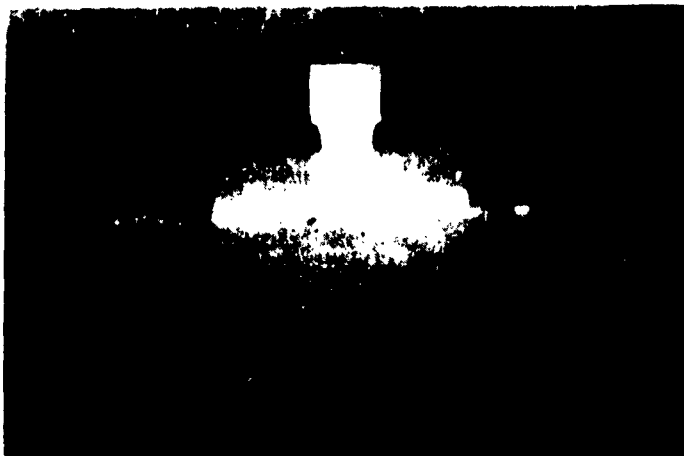

Fig. 7 - KEL-F VALVE

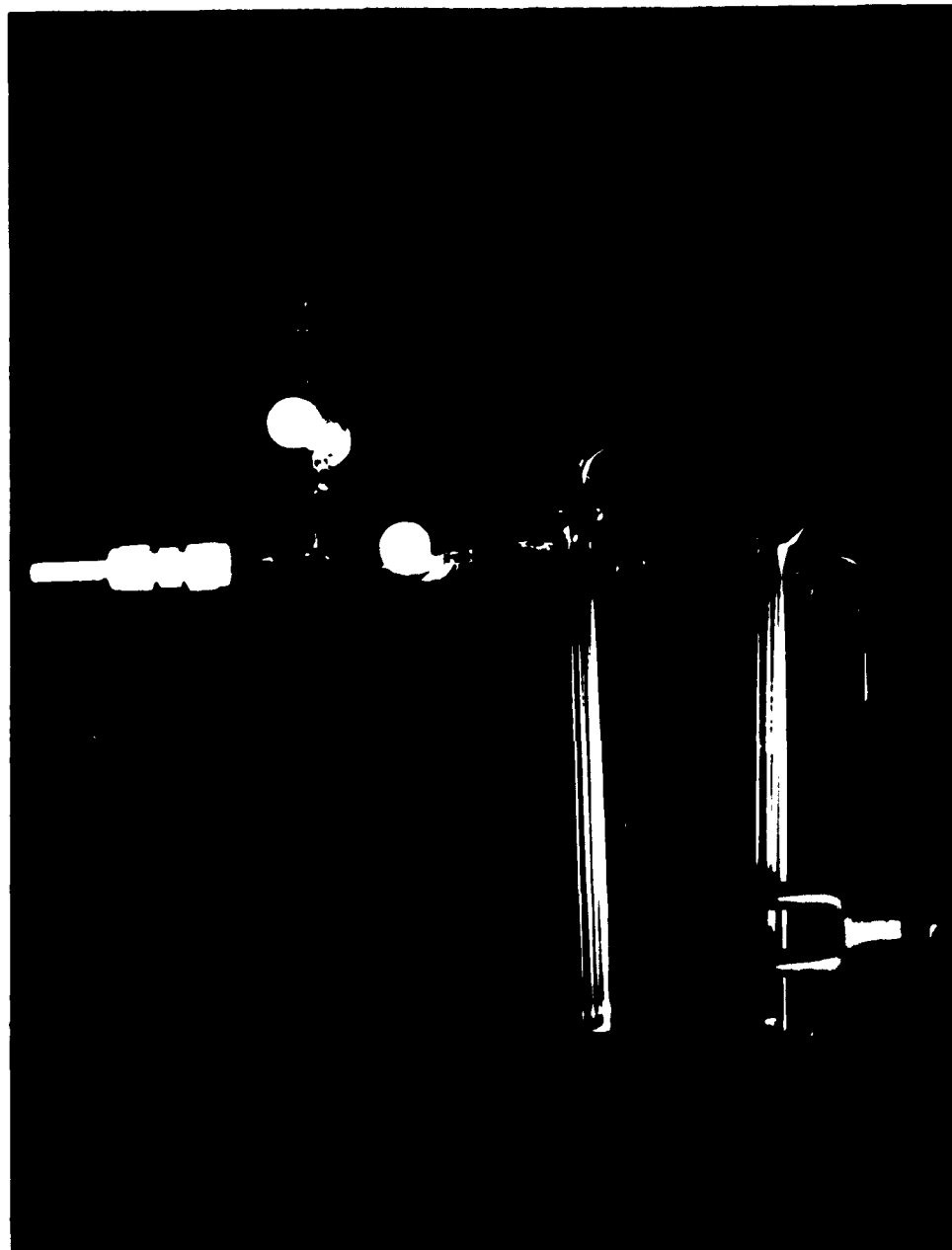

Fig. 8 -FLOW INDICATOR FOR FLUORINE

III. WORKING ELECTRODES

Work continued on the investigation of possible working electrode materials, including aluminum, titanium, antimony, bismuth, silver, copper, cobalt, iron, and monel. Of these metals Sb, Bi, and Ag had high anodic dissolution rates in HF and have been dropped from further consideration.

All the electrodes used for this report were in the form of 1/8" diameter rods. The upper end of each metal rod was inserted into 1/4" Teflon tubing and a banana plug soldered to the top of a small exposed portion of the rod. A good seal was obtained between electrode and cell.

For all polarization curves recorded in this report, approximately 3 cm² of the working electrode was exposed to the AHF in the electrolytic cell. In the graphs, a dotted line represents a rapid polarization curve (current recorded about 30 sec after the potential is changed), unless specified otherwise. Also, polarization did not start until the electrode had been in the cell for at least two hours and a Hg/Hg₂F₂ electrode was used as a reference unless stated otherwise.

In Table I several types of data are recorded:

1. The solubility of the fluorides of metals studied in this quarter.
2. Weight changes obtained at, open circuit, and/or constant current or potential.
3. The cleaning reagent used for the working electrode.

After using the cleaning reagent listed in Table I, the electrode was washed with distilled water and then with acetone. Before weighing an electrode it was dried under an IR lamp. On some metals fine sandpaper was used due to the lack of a desirable chemical cleaning reagent.

A. Antimony

Rapid anodic polarization curves were obtained on a clean antimony electrode (Figure 9). Platinum was used as a reference electrode. Antimony exhibited good reproducibility but corroded heavily at anodic potentials. At +2.0 v vs Pt, antimony lost 23.26 mg/cm² over a two-hour period. If all the steady-state current, about 6.7 ma/cm² at this potential, went to metal dissolution, the weight loss would be 20.3 mg/cm² assuming SbF₃ is formed. Thus it is evident that the anodic dissolution of antimony in AHF is too high for it to be used as a working electrode for the present purpose.

B. Bismuth

Rapid anodic polarization (Figure 10) of a clean bismuth electrode showed good reversibility; however, the corrosion rate was high. Over a period of 3 hrs (40 min during which a polarization curve was run and 2:20 hrs at open circuit) the weight loss was 24.6 mg/hr/cm² in AHF. Due to this high corrosion rate, bismuth cannot be used as a working electrode in AHF.

C. Silver

The weight loss on a silver electrode in AHF was 6.66 mg/hr/cm² at open circuit. Rapid anodic polarization (Figure 11) showed good reproducibility and stability. However, it is not suitable for use as a working electrode because of its high rate of corrosion, due to the formation of AgF, which is quite soluble in AHF (see Table I).

D. Aluminum

Polarization curves for aluminum in pure AHF were not reproducible and showed unstable behavior (2). The addition of NaHF₂ to the AHF made it possible to obtain stable and reproducible polarization curves (Figure 12). Addition of NH₃ to make a 0.01 molar solution did not result in any significant changes in

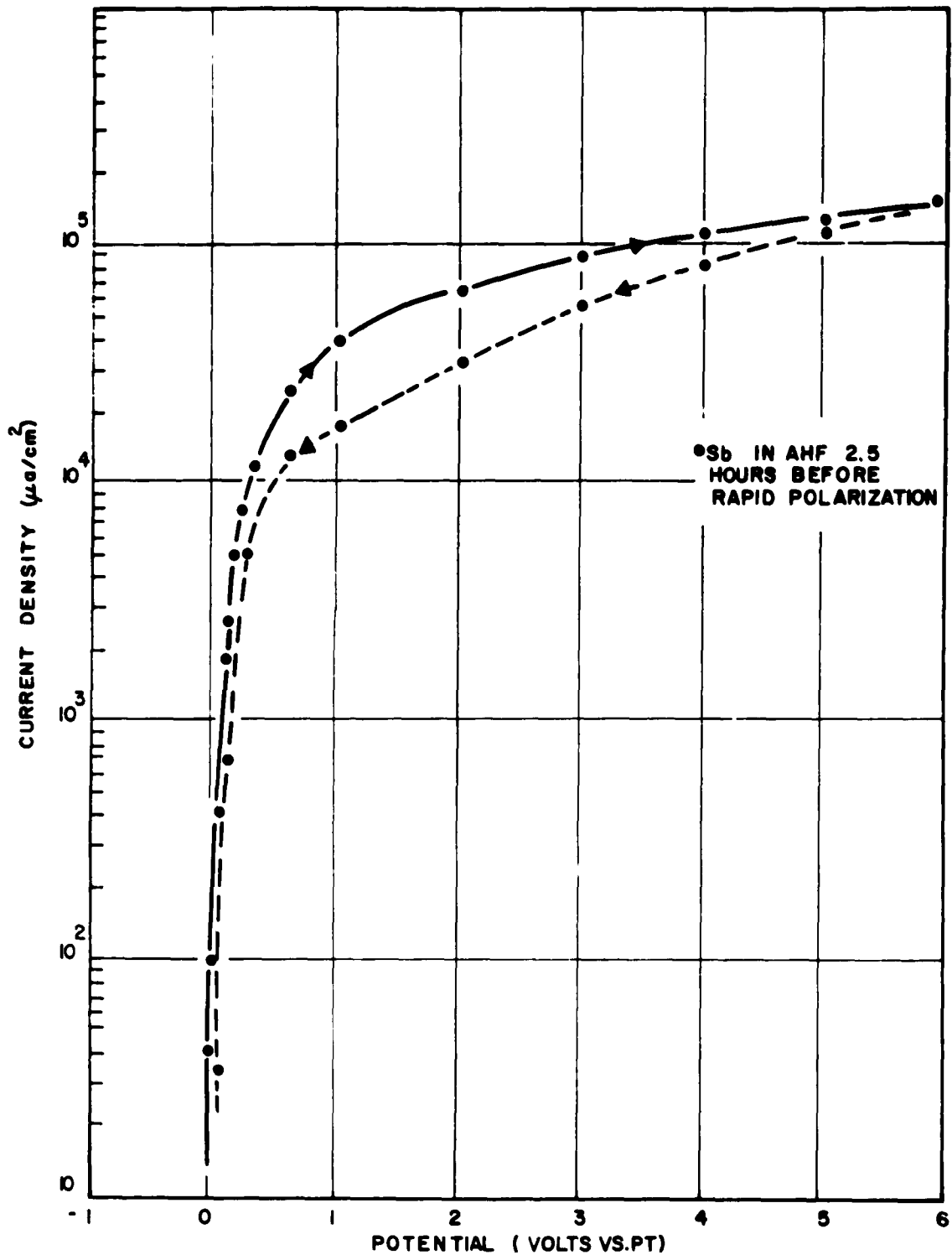

Fig. 9-POLARIZATION CURVES FOR ANTIMONY IN AHF

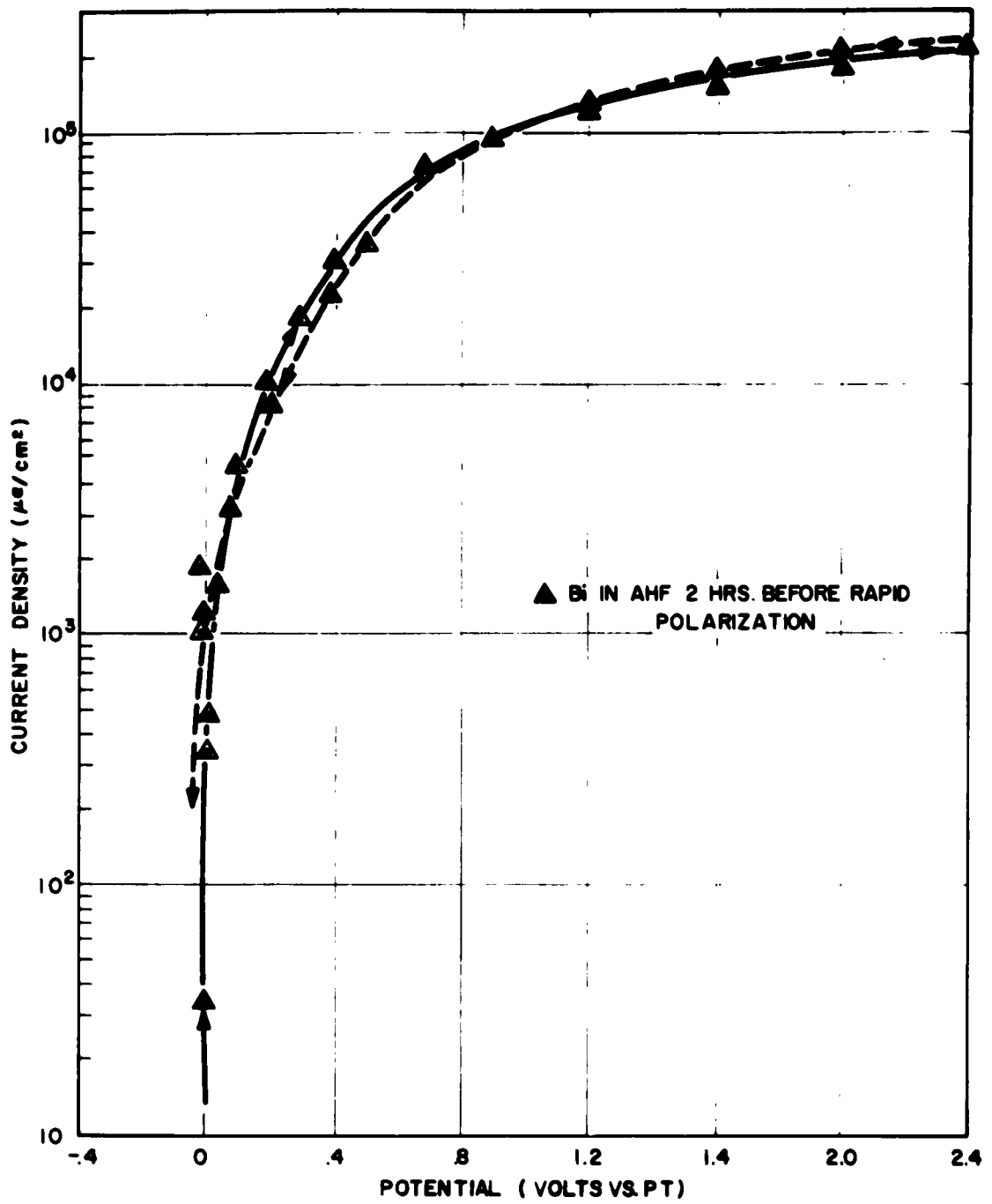

Fig. 10- POLARIZATION CURVES FOR BISMUTH IN AlF

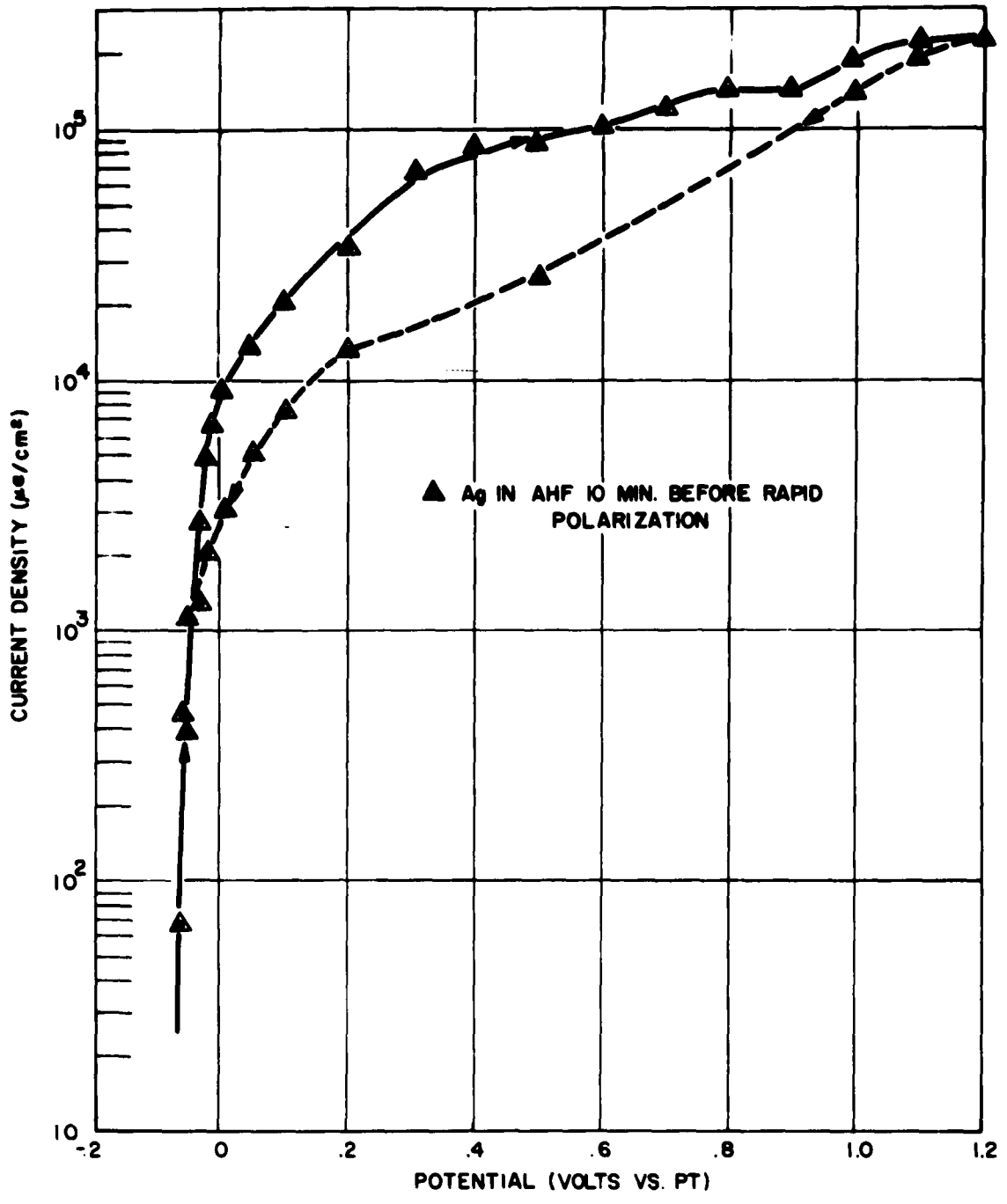

Fig. 11- POLARIZATION CURVES FOR SILVER IN AHF

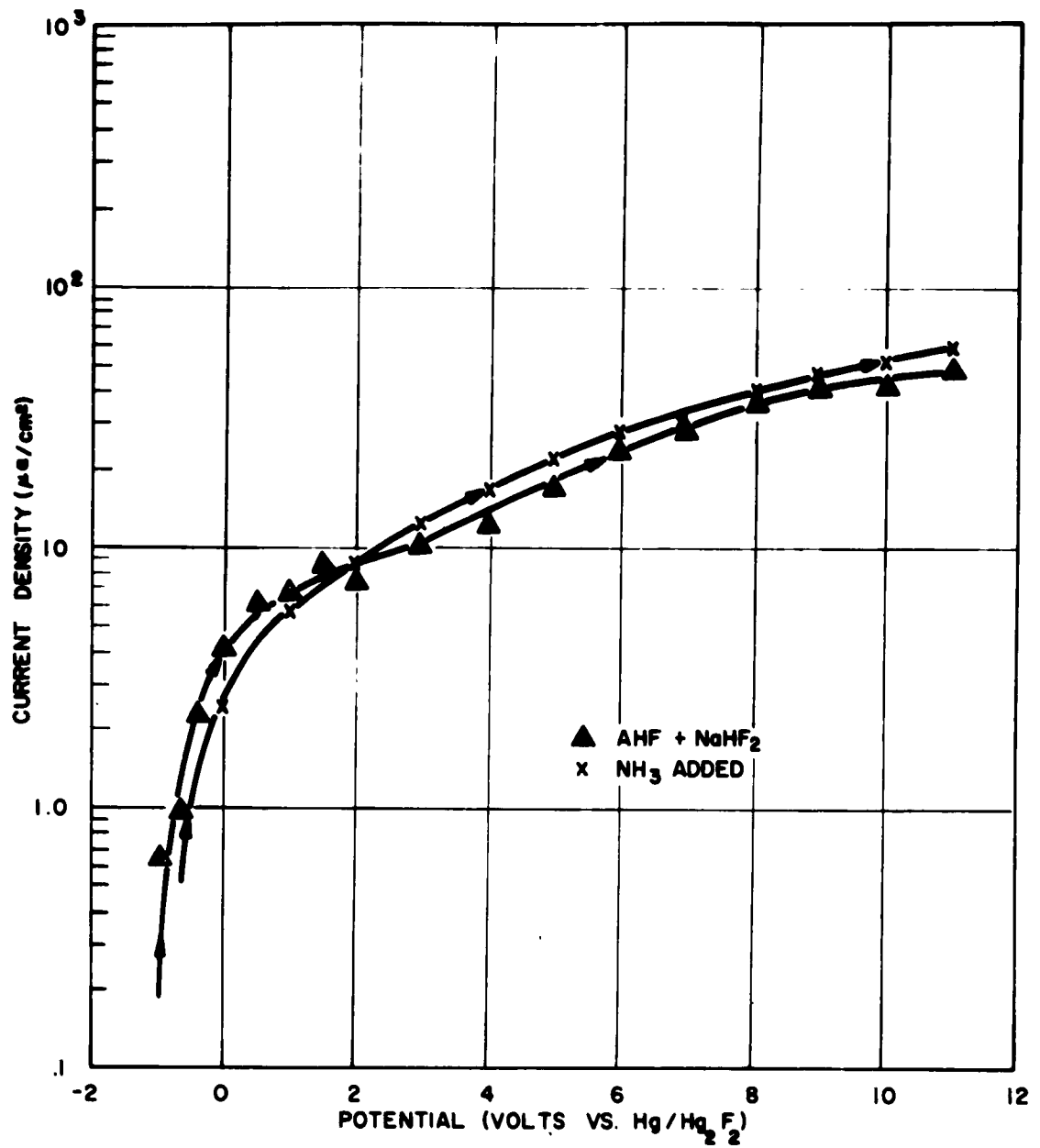

Fig. 12-POLARIZATION CURVES OF ALUMINUM IN AHF

the polarization characteristics.

Various treatments caused the growth of crystals on the aluminum electrode. For instance, distilled water was added to the AHF to make an 8% by volume solution of H₂O in HF. In this solution an Al electrode was cathodically biased at -3.0 v for 20 min and then removed from the cell. Upon contact with the air, crystals started growing in a planar configuration perpendicular to the electrode. These crystals grew to a length of about 1.5" during the first hour and reached a final length of about 6" after approximately 24 hours (Figure 13). It was observed that the crystal growth took place at the base rather than at the tip of the crystals.

E. Titanium

Anodic polarization of a clean titanium electrode showed a high degree of polarization and poor reversibility up to +10.0 v vs Pt (Figure 14). The titanium electrode showed a weight gain (Table I) after being in the cell for six hours, four hours of which was during polarization. The weight gain and the high polarization of titanium indicate a high resistance fluoride film which renders it unsuitable for use as a working electrode.

F. Cobalt

Rapid anodic polarization (Figure 15) of the cobalt electrode shows it to be quite irreversible. This may be accounted for by the presence of a high resistance fluoride film. The peak at +0.2 v is possibly due to formation of the film on the electrode. A weight gain (Table I) also indicates film growth on the cobalt electrode. Due to the formation of this film, cobalt is unsuitable for use as working electrode.

G. Iron

The polarization curves obtained were stable and reproducible with the iron showing very little corrosion on



**Fig. 13-CRYSTALLINE GROWTH ON
ALUMINUM ELECTRODE**

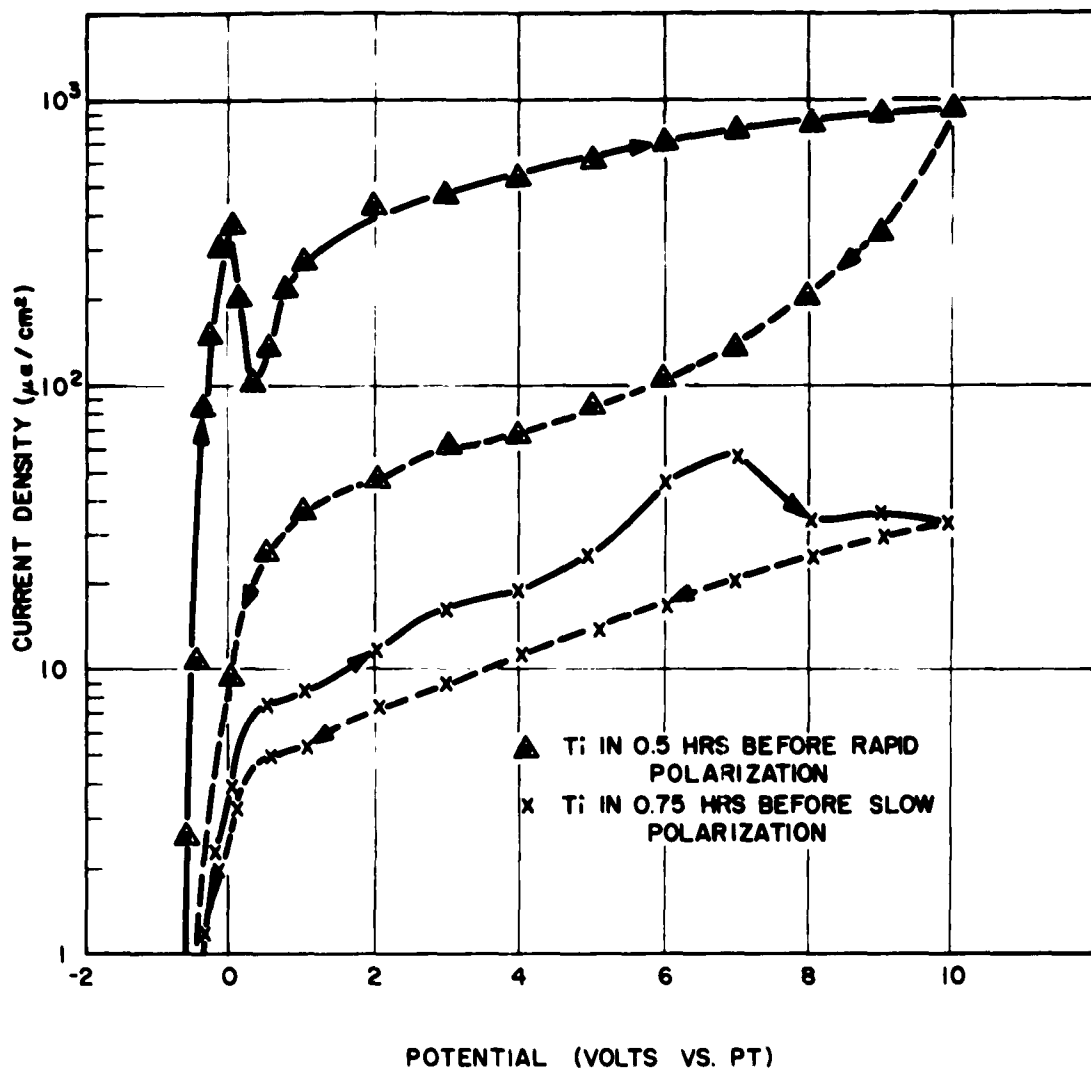

Fig. 14- POLARIZATION CURVES OF TITANIUM IN AHF

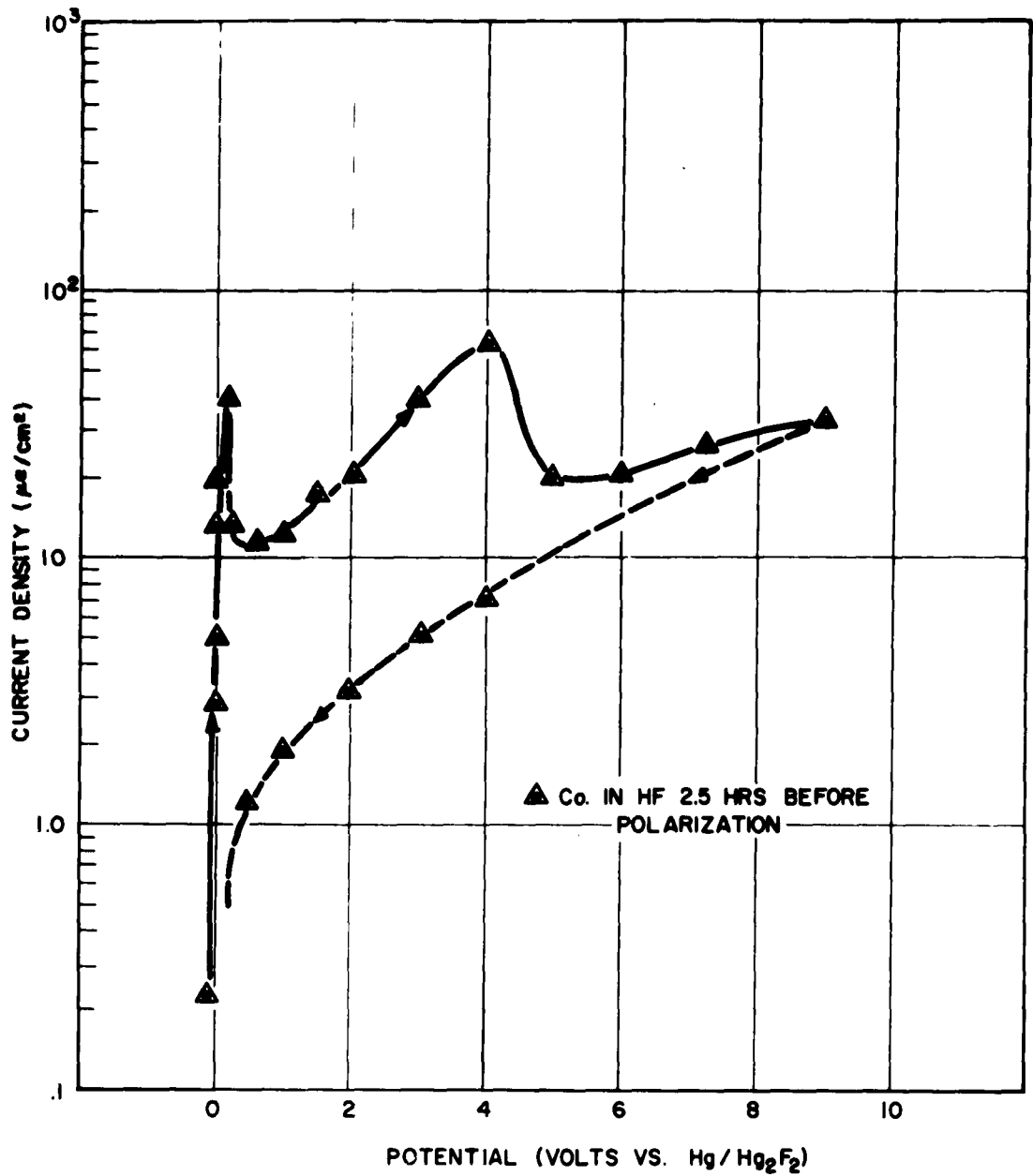

Fig. 15- POLARIZATION CURVES OF COBALT IN AHF + NaHF₂

TABLE I

METAL	METAL FLUORIDE	SOLUBILITY OF METAL FLUORIDES IN AHF (1) (g/100 g AHF)	TEMP (°C)	CLEANING AGENT	WEIGHT CHANGE (mg/hr/cm ²)
Sb	SbF ₃	0.191 ± 0.003	-23.8	Con. HCl	-11.63 ^a
Bi	BiF ₃	0.010 ± 0.002	-23.1	Dil. HNO ₃	-24.6 ^b
Ag	AgF	27.2 ± 0.7	-25.0	Fine Sandpaper	- 6.66 ^c
Ag	AgF ₂	0.024 ± 0.001	-25.2	Fine Sandpaper	+ 0.14 ^b
Ti	---	----	--	Sandpaper	
Co	CoF ₂	0.272 ± 0.016	-23.8	Dil. HCl	+ 0.109 ^b
Ni	CoF ₃	0.040 ± 0.003	-23.2	Dil. HCl	
Fe	FeF ₂	0.005 ± 0.002	-22.5	Dil. HCl	+ 0.184 ^d
Fe	FeF ₃	≤ 0.001	-25.2	Dil. HCl	
Cu	CuF ₂	0.010 ± 0.004	-23.1	Dil. HNO ₃	- 0.133 ^b
Monel	---	----	--	Dil. HNO ₃	(see Table II)

^a2.0 v vs Pt applied potential

^bopen circuit and polarization

^copen circuit only

^d300 ua applied current

anodic polarization (Figure 16). Addition of NaHF_2 had no significant effect on the curve. In order to determine if the current at high potentials was due mainly to fluorine evolution or to iron dissolution, the current was set at $300 \mu\text{a}$ for 18 hours. The weight loss observed (Table I) was approximately equal to the calculated weight loss (i.e., 3.8 mg calculated based on the formation of FeF_3 ; 4.1 mg observed). Therefore the current density observed past the potential for fluorine evolution (approximately 2.4 v) is probably due to iron dissolution and not fluorine evolution. Therefore, iron has been dropped from further consideration.

H. Copper

Stable and reproducible polarization curves were obtained (Figure 17). Copper evidently forms a high resistance film; only a small increase in current density is observed past 2.4 v where fluorine evolution should begin. Also, copper showed a weight gain of 1.39 mg after 12 hours at an applied potential of 6.0 v, indicating film formation. The addition of NaHF_2 to the HF had no significant effect on the anodic polarization curve. Thus, copper passivates readily in AHF, but forms a film of very low conductivity. The peaks in the polarization curve may be due to an initial film formation and to a possible reorientation of the film.

I. Monel

Monel electrodes have shown high resistance to corrosion under conditions of open circuit and anodic polarization. Weight loss measurements were made on a clean monel (#400 alloy) electrode at open circuit, +8 v, and +12 v. The results are listed in Table II.

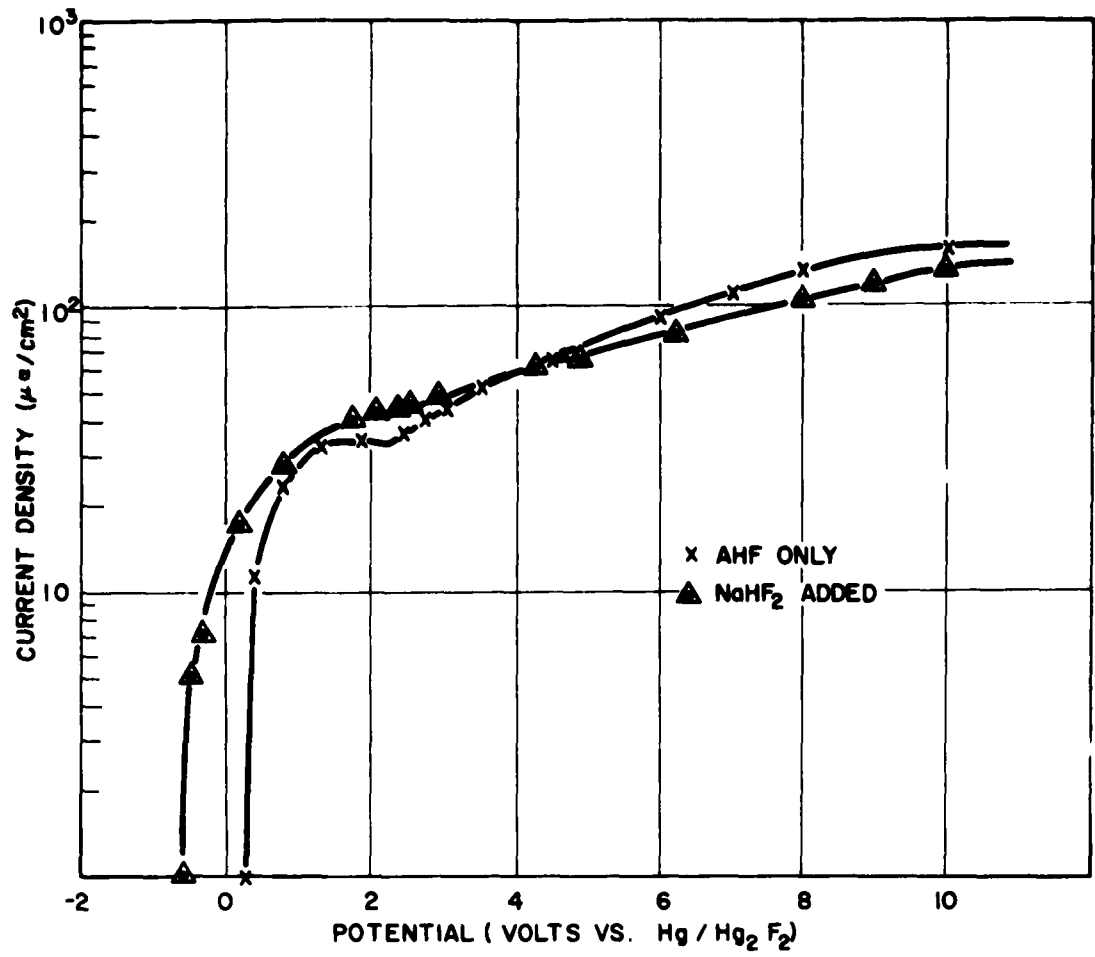

Fig. 16- POLARIZATION CURVES FOR IRON IN ANHYDROUS HF

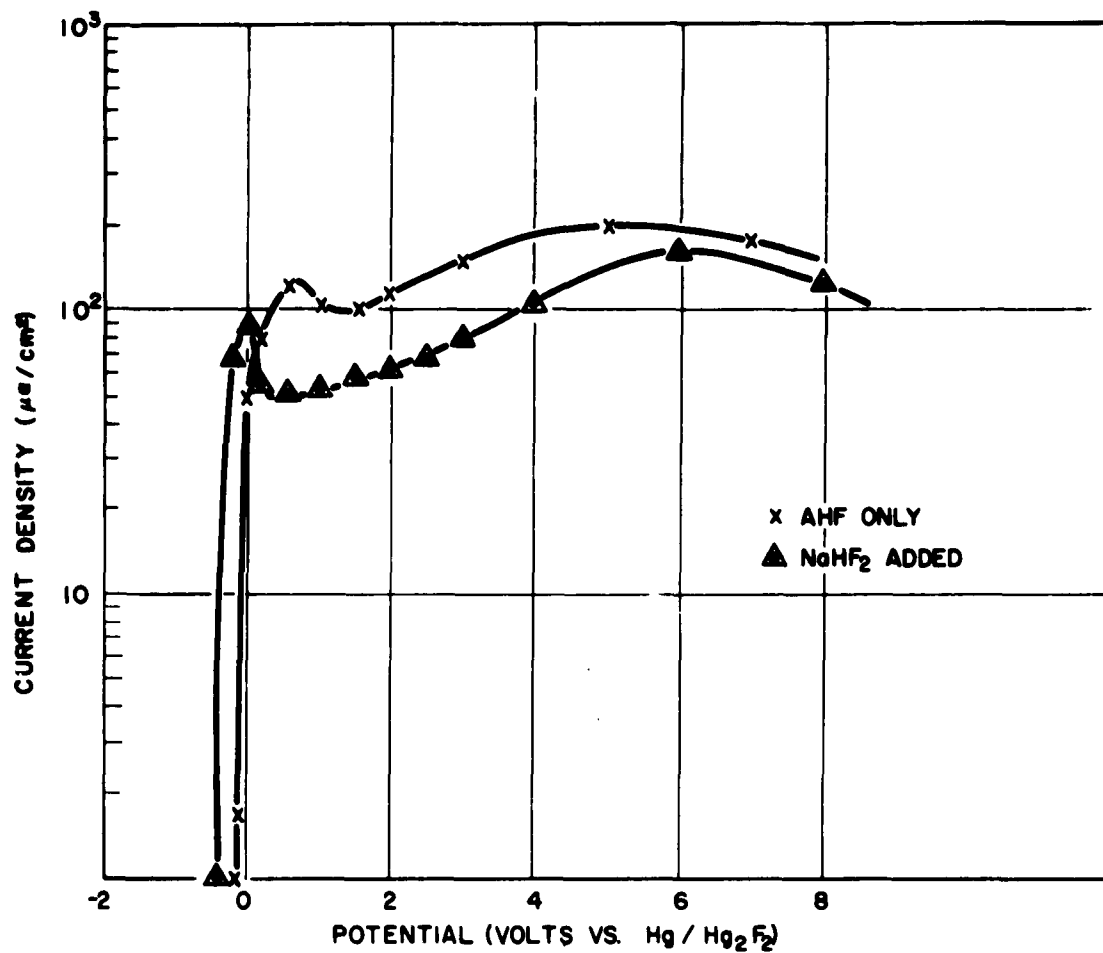

Fig. 17- POLARIZATION CURVES FOR COPPER IN ANHYDROUS HF

The polarization curves obtained for monel in AHF are reproducible and stable. Anodic and cathodic polarization curves are shown in Figure 18. It was noted in Quarterly Status Report No. 4 that anodic polarization curves on aluminum had a definite peak if the metal had not been in the HF for at least several hours. The same observation was made on monel as can be seen in Figure 19. On cathodic polarization the protective film is apparently removed as indicated by the high currents shown in Figure 18.

From the weight loss data on monel (Table II), it seems that the corrosion current is relatively low and that the current increase past ~ 2.8 v is due mainly to fluorine evolution. A hysteresis is noted when the reverse polarization is done quickly, but if the current is allowed to return to a steady state at each point, the curve is rather reversible. Polarization of monel beyond + 10 v showed a slight decrease in current up to + 18 v (Figure 18). This may be due to either thickening of the film or to development of "secondary passivity." Further studies are being made in this area.

Film resistance measurements were made on a monel electrode using a Tektronix 431 oscilloscope to record the instantaneous potential drop (IR drop) at the electrode interface when the potentiostat was switched out by use of a Western Electric relay. No film resistance was found up to 10 v. Measurements at higher potentials are planned.

Potential decay measurements were also made on a monel electrode using a Texas Instruments Recorder driven by a Keithley 600-A Electrometer. From 3.6 v the potential quickly decays to its open circuit value. From 3.6 v to 6.0 v the potential decay time increases and the final potential (after 30 sec) is positive to the open circuit value. From above 6 v the potential decays rapidly to a plateau at about 2.6 v (from 10 v in 3 sec). This indicates the buildup of a fluoride (conducting) film on

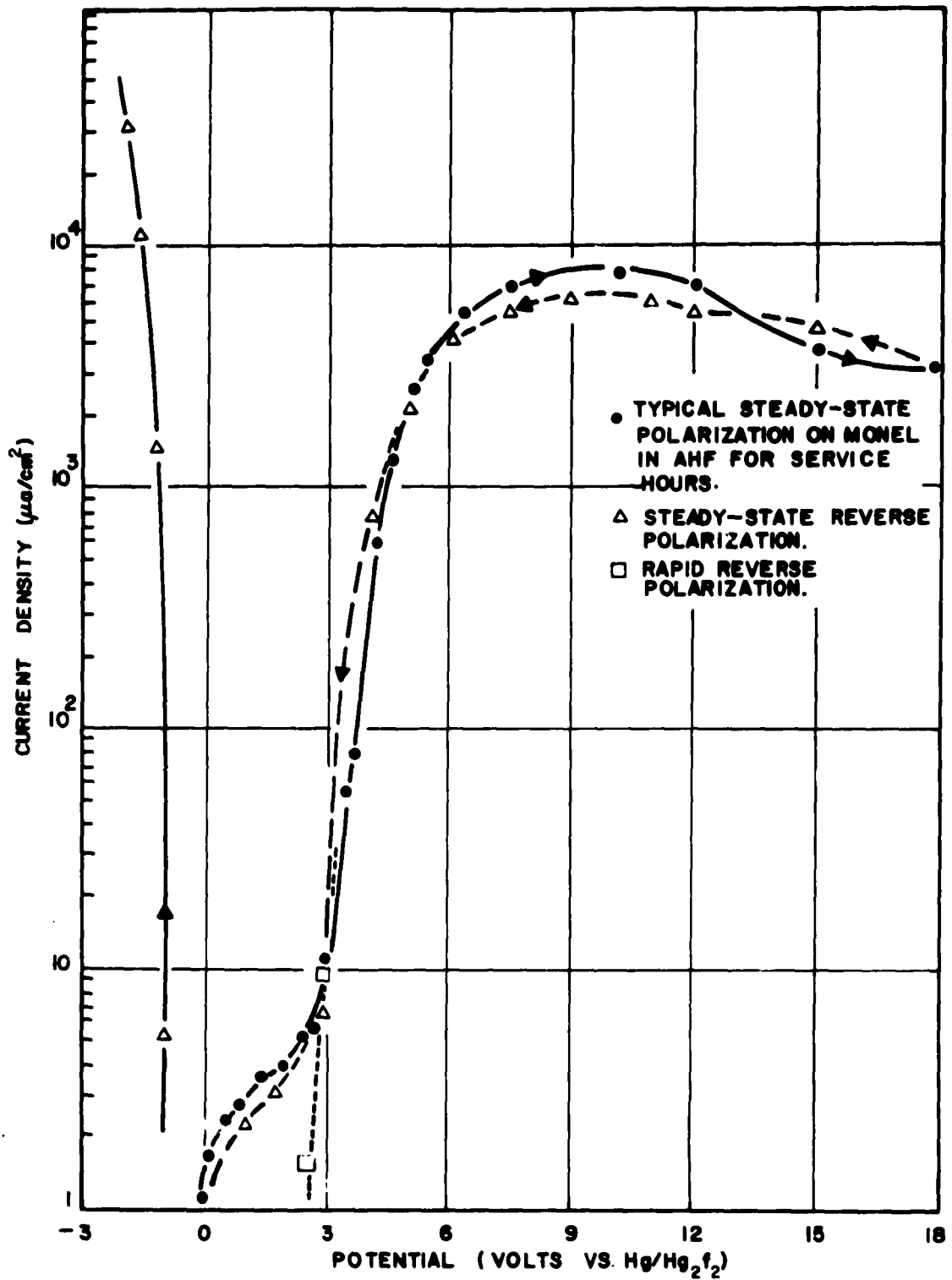

Fig. 18-POLARIZATION CURVES OF MONEL IN AHF

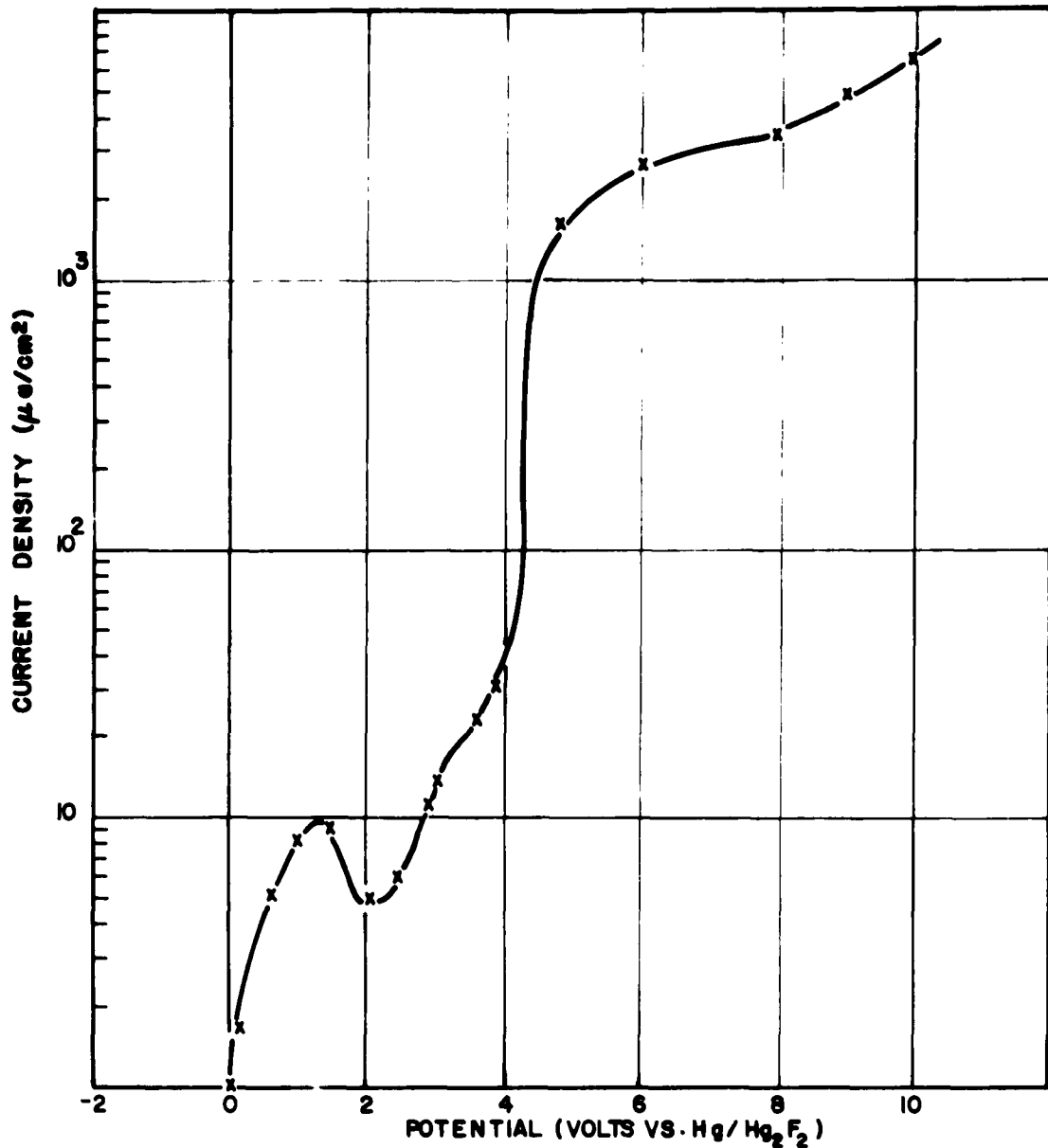

Fig.19-POLARIZATION CURVE FOR MONEL (IN ANHYDROUS HF FOR 30 MINUTES)

TABLE II

POTENTIAL	WEIGHT LOSS, mg/cm ² /hr	
	Measured	Calculated From Current Passed*
Open circuit	- .154	-----
8 volts	+ .054	+ 15.4
12 volts	+4.4	+ 8.2

* assuming formation of NiF₂ and CuF₂.

the electrode, which also accounts for the hysteresis during rapid reverse polarization (Figure 18).

Ammonium fluoride was added to HF and anodic polarization curves taken using monel as the working electrode (Figure 20). Two definite peaks were noted at 0.0 v and 3.4 v. This curve appears to be stable and reproducible. Work is now in progress to determine the significance of these two peaks. It seems that the area under the current vs time curve at 0.0 v is directly proportional to the amount of NH_4F added. If a polarization curve is repeated after one for which NH_4F had been added, neither of the two peaks is present (Figure 21), and the current remains around $1 \mu\text{a}$ from the open circuit potential up to at least +1.0 v.

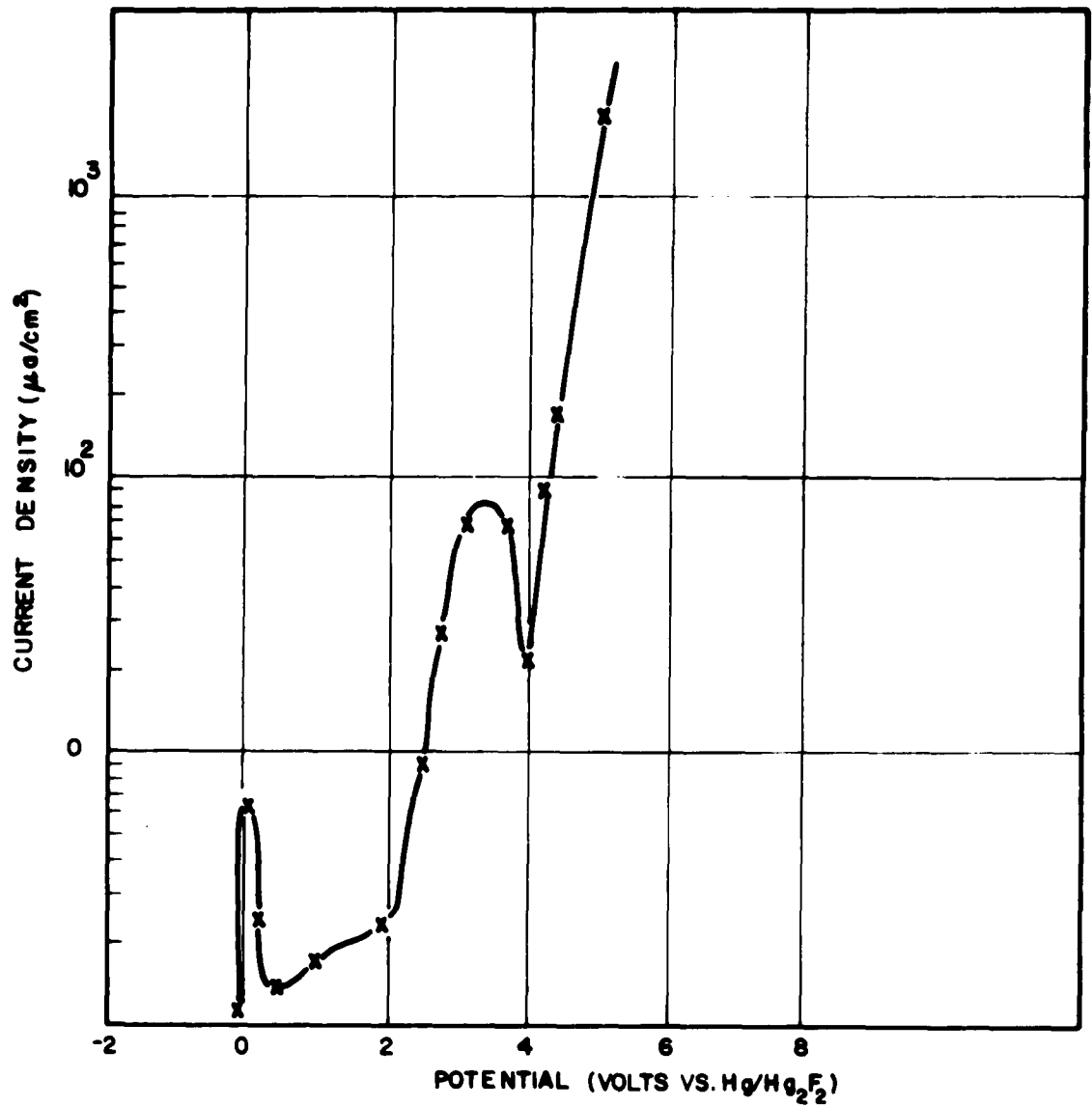

Fig.20 - POLARIZATION CURVES FOR MONEL (IN ANHYDROUS HF AFTER ADDITION OF NH_4F)

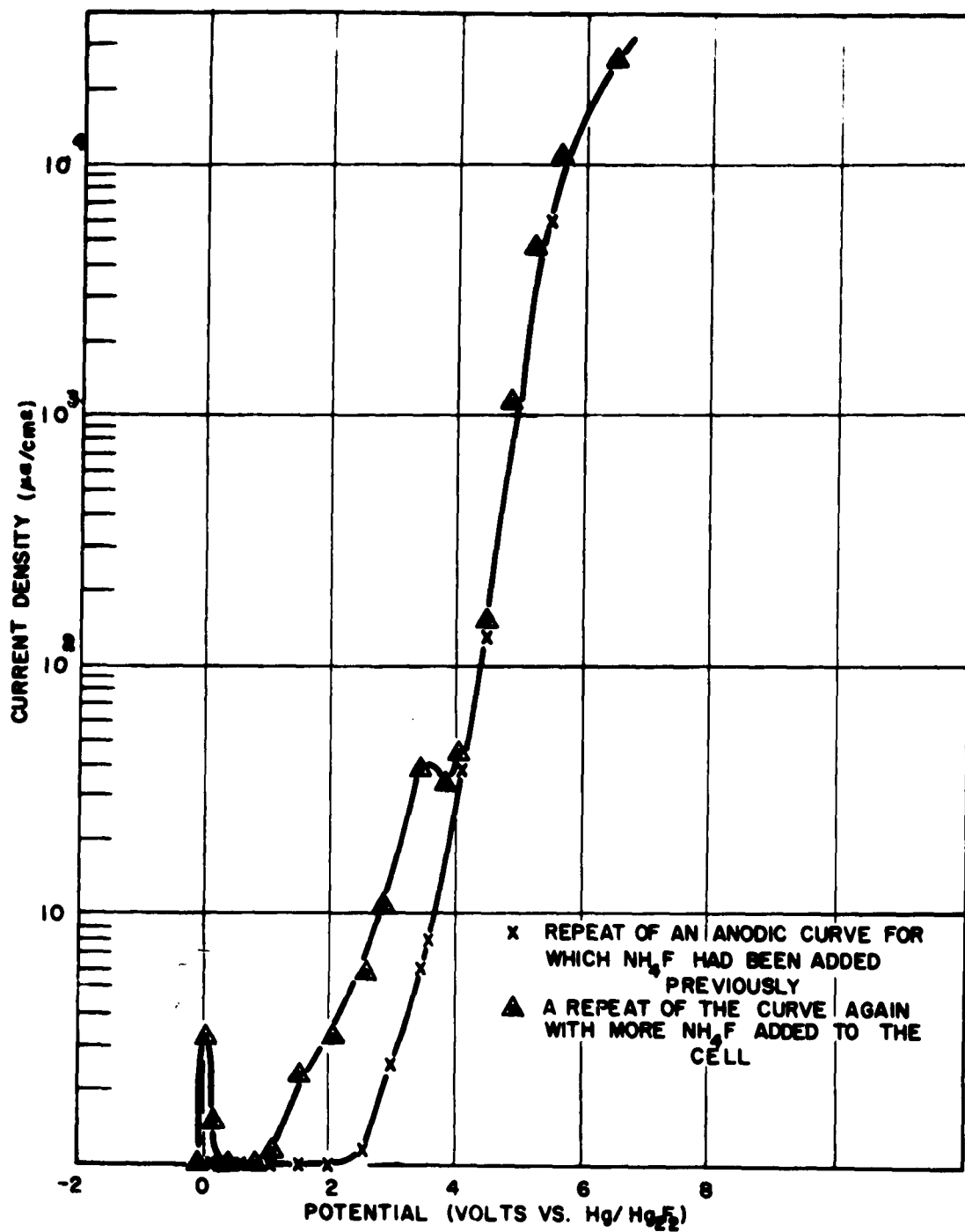

Fig. 21-POLARIZATION CURVES FOR MONEL IN ANHYDROUS HF

IV. DISCUSSION

Work is still continuing on the selection of a material for a stable working electrode; however, monel will be used to study the electrochemical synthesis of N-F compounds until a better electrode is found. The polarization curves and the IR-drop measurements and weight loss data taken on monel electrodes indicate that the film formed up to +8v is a good electronic conductor and protective. The significance of the peaks in the anodic polarization curve for monel in AHF + NH₄F is presently under study.

V. FUTURE WORK

Three specific electrode materials which will be investigated in the next quarter will be molybdenum, pyrolytic carbon, and zirconium diboride. A pyrolytic carbon electrode is being constructed using a small disc of the material molded in Kel-F such that only the surface of the lamella will be in contact with the HF. This should make it resistant to exfoliation. The molybdenum and the zirconium diboride will be in the form of 1/8" rods.

It is hoped that by using Kel-F tubing, cells, and valves the purity of the HF may be retained for longer periods of time.

Work now in progress consists of polarization studies in AHF with NH_3 , N_2H_4 , NH_4F , and NaHF_2 added using monel as the working electrode.

Some investigations will be carried out in the next quarter to complete the studies on copper.

REFERENCES

1. Jache, A. W. and Cady, G. H., J. Phys. Chem. 56, 1106 (1952).
2. Hurd, R. M., Snavely, E. S., Jr., Fiel, L. D., Spears, L. G., and Harrell, W. E., Jr., "Electrochemical Studies in the Synthesis of N-F Compounds", Quarterly Status Report No. 4, TRACOR, Inc. Document No. 64-154-U dated March 31, 1964, p. 23.

DISTRIBUTION LIST

Advanced Research Projects Agency Propellant Chemistry Room 3D165, The Pentagon Washington 25, D. C.	6 copies
Defense Documentation Center (formerly ASTIA) Arlington Hall Station Arlington 12, Virginia	10 copies
Chemical Propulsion Information Agency (formerly LPIA and SPIA) Applied Physics Laboratory The Johns Hopkins University Silver Spring, Maryland	3 copies
Office of Naval Research Power Branch, Code 429 Navy Department Washington 25, D. C.	2 copies
Commanding Officer Office of Naval Research Branch Office 86 East Randolph Street Chicago 1, Illinois	1 copy
Department of the Navy Inspector of Naval Material 708 Jackson Street Dallas 2, Texas	1 copy

NOTE: Additional copies were distributed according to Chemical Propulsion Mailing List following CP123, dated June 1963.