

UNCLASSIFIED

AD NUMBER

AD432252

LIMITATION CHANGES

TO:

Approved for public release; distribution is unlimited. Document partially illegible.

FROM:

Distribution authorized to U.S. Gov't. agencies and their contractors;
Administrative/Operational Use; SEP 1963. Other requests shall be referred to Naval Weapons Laboratory, Code WHR, Dahlgren, VA. Document partially illegible.

AUTHORITY

dwl per dtic form 55

THIS PAGE IS UNCLASSIFIED

UNCLASSIFIED

AD

432252

DEFENSE DOCUMENTATION CENTER

FOR

SCIENTIFIC AND TECHNICAL INFORMATION

CAMERON STATION, ALEXANDRIA, VIRGINIA



UNCLASSIFIED

NOTICE: When government or other drawings, specifications or other data are used for any purpose other than in connection with a definitely related government procurement operation, the U. S. Government thereby incurs no responsibility, nor any obligation whatsoever; and the fact that the Government may have formulated, furnished, or in any way supplied the said drawings, specifications, or other data is not to be regarded by implication or otherwise as in any manner licensing the holder or any other person or corporation, or conveying any rights or permission to manufacture, use or sell any patented invention that may in any way be related thereto.

64-10

482252



CATALOGED BY DDC
AS AD No.

Laboratory Memorandum

LN-B1980-2

HERO COMPONENT TESTING HANDBOOK

by

Norman P. Faunce

30 September 1963

Prepared for

**U. S. NAVAL WEAPONS LABORATORY
Dahlgren, Va.
Code VHR**

Contract No. N178-8102

DDC
MAR 19 1964
TISIA B

482252

THE FRANKLIN INSTITUTE

LABORATORIES FOR RESEARCH AND DEVELOPMENT
PHILADELPHIA PENNSYLVANIA

Laboratory Memorandum

LM-B1980-2

HERO COMPONENT TESTING HANDBOOK

by
Norman P. Faunce

30 September, 1963

Prepared for
U.S. Naval Weapons Laboratory
Dahlgren, Va.
Code WHR

Contract No. N178-8102

TABLE OF CONTENTS

	<u>Page</u>
1. INTRODUCTION	1
2. EED EVALUATION	3
2.1 Basic Firing System	4
2.2 Calibration Procedures	6
2.2.1 Voltage-Impedance Method	7
2.2.2 Voltage Min-Max Method	9
2.2.3 Calibrated Bridgewire Method	13
2.3 Detailed Firing Systems	15
2.3.1 Equipment Used at 5 to 10 Mc (CW)	15
2.3.2 Equipment Used at 250 to 500 Mc (CW)	18
2.3.3 Equipment Used at 400 to 1350 Mc (CW).	20
2.3.4 Equipment Used at 2500 to 3500 Mc, CW or Pulsed	23
2.3.5 Equipment Used at 4500 to 5500 Mc, CW or Pulsed	26
2.3.6 Equipment Used at 8500 to 10,000 Mc, CW or Pulsed	29
3. PROTECTIVE SCHEME EVALUATION	33
3.1 Determination of Worst Case Attenuation	33
3.1.1 Dissymmetrical Network Model Attenuation	33
3.1.2 Matched Attenuation Determination.	35
3.2 Procedure for Making Dissipative Attenuation Measurements.	38
3.3 Terminated Power Loss Measurements	40
ACKNOWLEDGEMENTS	42
APPENDIXES	43
A-1 Statistical Techniques	44
A-2 RF Mounting Considerations	50

LIST OF FIGURES

<u>Fig. no.</u>		<u>Page</u>
2-1	Basic RF Firing System	5
2-2	RF Firing System Employing Voltage-Impedance Method for Calibration	8
2-3	RF Firing System Arrangement for Voltage Min-Max Calibration	11
2-4	Basic Arrangement for Firing System Calibration by the Calibrated Bridgewire Method	14
2-5	Firing System; 5 to 30 Mc CW	16
2-6	Firing System; 250 to 500 Mc CW	19
2-7	Firing System; 400 to 1350 Mc CW	21
2-8	Firing System; 2500 to 3500 Mc CW or Pulsed	24
2-9	Firing System; 4500 to 5500 Mc CW or Pulsed	27
2-10	Firing System; 8500 to 10,000 Mc CW or Pulsed	30
3-1	Dissymmetrical T Network and Load	34
3-2	IF Substitution Method for Measuring Dissipation Attenuation	36
3-3	Basic Dissipative Network	40

1. INTRODUCTION

Of the many functions of the HERO group, one important task is the evaluation of components used in initiator firing systems. These include all types of initiators in current use plus RF protective schemes or "fixes". In addition, recommendation for increased protection from RF are often required. The development of approved testing methods is therefore a necessary and important responsibility of the HERO group.

The purpose of this handbook is to describe such RF evaluation systems developed at The Franklin Institute Laboratories, which are related to the HERO effort. Specifically it details two broad categories of tests: (1) determination of sensitivity of EEDs to RF, and (2) determination of RF loss afforded by various means applicable to EED's and circuits.

Underlying the test schemes described is the principle of evaluation held by Franklin Institute since its first encounter with HERO problems. Basic to our approach to assessing potential vulnerability is the determination of the RF sensitivity of the EEDs when they are configured to be responsive to the least possible power. Similarly we advocate determining the "worst-case" loss of any component introduced in the firing system whether or not its introduction is intended to decrease the system's RF sensitivity. A terminated power loss determination is recommended as an alternative, but this can be used only if the load impedance can be guaranteed. Test procedures and equipment recommended herein are biased by this outlook, but otherwise are limited only by the state-of-the-art. Many additional tests of initiators are necessary to describe completely all the EED functioning characteristics, but these are not included in this compilation. For information relevant to these related tests reference is made to the extensive library at Naval Weapons Laboratory, Dahlgren, and at The Franklin Institute.

LM-B1980-2

To determine the probable vulnerability of any system it is necessary to perform rigorous analyses of each and every unique system. These analyses must take into consideration the probable source of RF energy (many RF generators can often be found built into an ordnance system otherwise effectively shielded from external RF energy), the antennas responsible for its interception, and the path by which it is conducted to the EED. Knowledge of the basic sensitivity of the EED, and the reliable (worst case) loss of the transmission system is essential to this procedure.

2. EED EVALUATION

The procedure for evaluating the RF sensitivity of electro-explosive devices is initiated by (1) selecting the test method, (2) selecting the evaluation system, and (3) preparing the EED's and the test system. With this done, the prescribed number of initiators are exposed to the appropriate test conditions and resulting data is reduced.

For an ordinary hot-wire bridged EED the test procedure is usually according to the Bruceton plan but sometimes the data are analyzed by the probit method. A brief summary of these are given in Appendix A-1. Other forms of EED, the EBW for example, may require special test procedures; because of their peculiarities, they are not readily amenable to treatment described in this report.

Selection of the system or systems depends upon the extent of testing required. If information is required only throughout a limited range of frequencies, only one system may be required; or the range may be so extensive as to require several systems. We have categorized our systems on the basis of calibration procedure, modulation, plumbing limitations, and signal source availability. As a result we now possess systems covering the following frequency ranges.

5 - 30	Mc CW
250 - 500	Mc CW
400 - 1350	Mc CW and Pulsed
4500 - 5500	Mc CW and Pulsed
8500 - 10,000	Mc CW and Pulsed

The equipment comprised by these systems and the special calibration procedures will be described in greater detail in the sections to follow.

THE FRANKLIN INSTITUTE • *Laboratories for Research and Development*

IM-1980-2

Preparation of the EED involves random sampling as appropriate, and making the necessary mounting fixtures for the specific RF systems involved in the test schedule. For details concerning sampling plans, reference is made to any standard tests on statistics; a description of mounting or means of connection to the RF system, is given in Appendix A-2.

2.1 Basic Firing System

The basic system used in performing RF sensitivity tests is outlined in Figure 2-1. The RF generator supplies power to a transmission line, and is suitably isolated to afford both frequency and power stability. Two directional couplers and indicators are used to measure the incident and the reflected powers in the transmission line. A switch permits the selection of either a standard termination (a dummy load) which is capable of absorbing all of the incident power, or a termination consisting of a matching section followed by the electro-explosive device in an especially designed mounting fixture. For those signal sources that provide pulse-modulated RF a rate generator must be included. A chronograph is provided for determining firing time; it is started by application of power and stopped by a signal from a photocell detector. To adjust the power delivered to the test specimen it is necessary to include a variable attenuator, and the various calibration procedures require other components which are not shown in the basic system. These are special refinements that are included in the system detailed in Section 2.3.

It is necessary that the impedance of the specimen under test be transformed or matched to the 50-ohm impedance of the signal generator. This is done by a matching system, consisting of variable reactive elements which may be either lumped or distributed, depending on the frequency used.

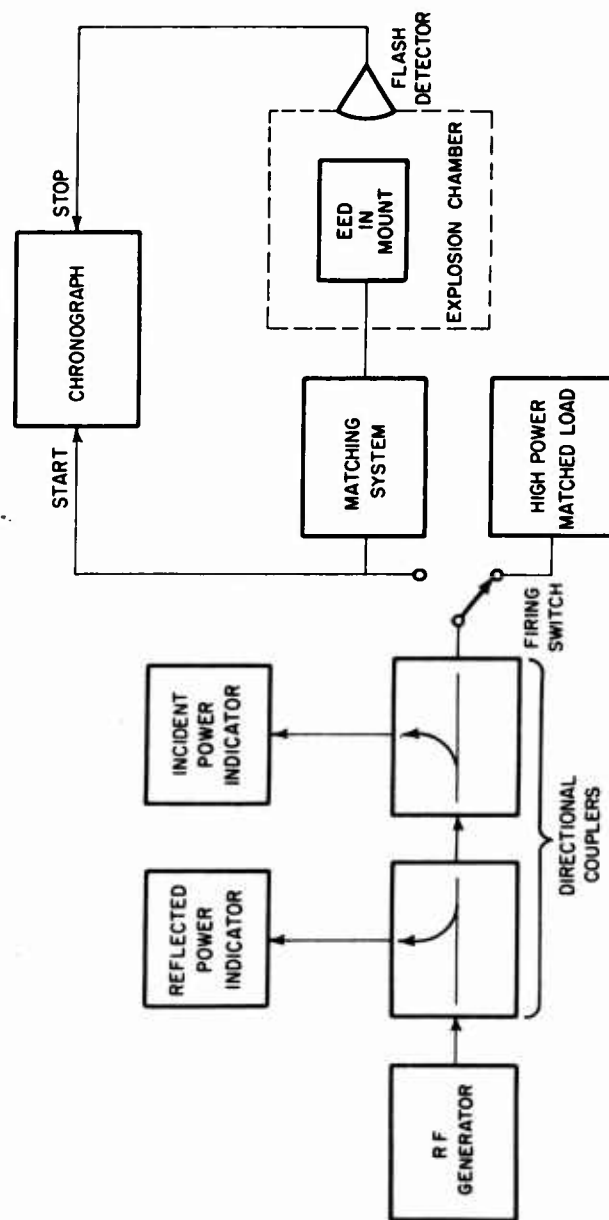

FIG 2-1. BASIC RF FIRING SYSTEM

Because of the complexity of RF phenomena a singular calibration procedure is not possible. At frequencies below 500 Mc where the impedance concept has meaning, we recommend the voltage-impedance technique. Above 1 Gc the wavelength is of a magnitude approaching the physical dimensions of the system components, and we propose the use of a "voltage min-max" technique. This can be employed at much lower frequencies, but below 500 Mc the increasing wavelength introduces severe equipment limitations. Between 500 and 1000 Mc it is possible to choose either technique.

An additional calibration procedure is described for use where all others may fail. This method, the bridgewire calibration technique, is reasonable at very low frequencies, and may be valid up to 1 Gc. Its limitation for frequencies around 1 Gc lies in the fact that it fails to take account of losses in the EED plug; beyond 1 Gc the reliability of available detectors is questioned.

2.2.1 Voltage - Impedance Method (5 to 500 Mc Tests)

For frequencies below 500 Mc the voltage-impedance method is used to calibrate the firing system. In this, the input impedance at the line section that forms part of the EED mount is determined for a representative group (about five units chosen at random). With the device terminating the system as shown in Figure 2-2, low level RF power is applied. The impedance matching network is adjusted to give minimum reflected power, thereby matching the low impedance of the load termination to the 50-ohm system. By this means the magnitude of RF power applied to the line section beyond the firing switch may be accurately determined. This determination is ordinarily made with a 50-ohm calorimetric power meter as a temporary termination. The incident power indicator may be calibrated to read this power as well.

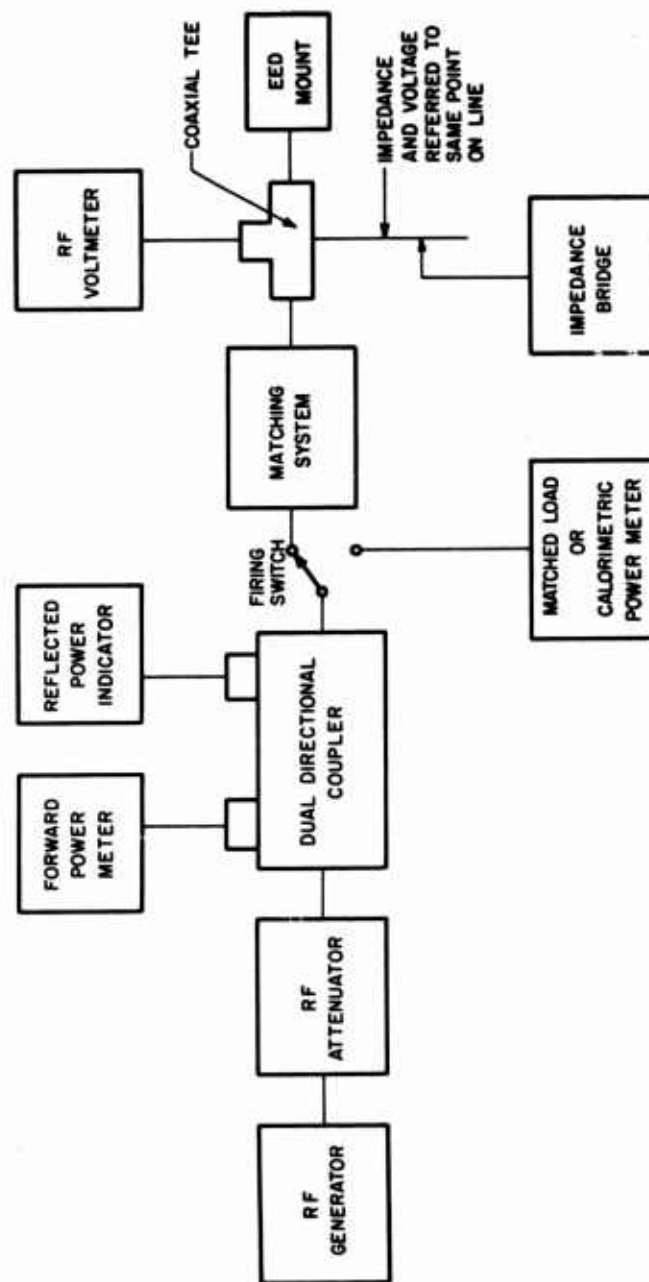

FIG. 2-2 RF FIRING SYSTEM EMPLOYING VOLTAGE-IMPEDANCE METHOD FOR CALIBRATION

With a given input power at the firing switch, the magnitude of the rms voltage, at the same point of the line at which the impedance was found, is determined by a direct reading RF voltmeter and suitable probes. The power (P_n) at the line section is derived from the expression⁽¹⁾

$$P_n = V^2 G = \frac{V^2 R}{R^2 + X^2}$$

where

P_n = real power in watts, at specified line section, which is dissipated in the load and in the section of coaxial line leading to the load.

V = RMS magnitude of voltage

R = magnitude of the real part of the terminating impedance

X = magnitude of the imaginary part of the terminating impedance

We then form the desired ratio P_n/P_{in} , where P_n is obtained as defined above and P_{in} is the power determined at the firing switch. The above ratio is the system transfer efficiency, and is used to relate the Bruceton levels to the real power arriving at the input leads of the EED (the small loss associated with the coaxial line between the voltage probe and the load itself is neglected).

2.2.2 Voltage Min-Max Method (1 to 10 Gc, CW or Pulsed)

The net power flow in an arbitrarily terminated transmission line can be expressed in terms of the voltage standing wave maximum and minimum by the expression⁽²⁾

$$P_n = \frac{V_{max} V_{min}}{R_0} \quad (\text{watt}) \quad (1)$$

(1) Moe Wind, (Ed), Handbook of Microwave Measurements, Polytechnic Institute of Brooklyn, July 1956.

(2) Handbook of Electrical Measurements; Edited by Moe Wind, Polytechnic Institute of Brooklyn, July 1956.

where P_n = net power (watt)
 V_{\max} = RMS magnitude of line voltage at a voltage maximum (volt)
 V_{\min} = RMS magnitude of line voltage at a voltage minimum (volt)
 R_o = characteristic impedance of transmission line (ohm)

A slotted section of transmission line with a voltage probe, shown in Figure 2-3, is required for measurement of V_{\max} and V_{\min} . In so doing, a relationship must be established between the probe's output voltage and the true RF voltage on the transmission line. By terminating the line with a power meter whose input impedance equals the characteristic impedance of the line (R_o) a unity standing wave ratio will be obtained. For this condition, the line voltage at any position V_x is related to the load power P_L by

$$P_L = \frac{V_x^2}{R_o} \quad (\text{watt}) \quad (2)$$

The work is simplified if, instead of finding V_x directly, we use D_x , the probe output indicated on the probe galvanometer. This is obtained from

$$P_L = \frac{V_x^2}{R_o} f(D_x) \quad (\text{watt}) \quad (3)$$

In an arbitrarily terminated system, values of D_{\max} and D_{\min} obtained from the slotted line are related to the corresponding quantities V_{\max} and V_{\min} by Equation (3), which may be rewritten

$$V_{\max} = \sqrt{f(D_{\max}) R_o} \quad (\text{volt}) \quad (4)$$

or

$$V_{\min} = \sqrt{f(D_{\min}) R_o} \quad (\text{volt}) \quad (5)$$

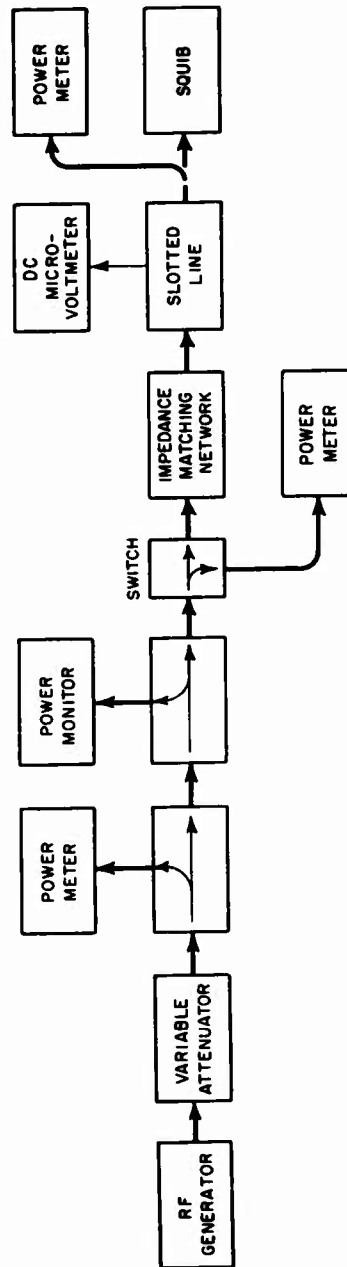

FIG. 2-3. RF FIRING SYSTEM ARRANGEMENT FOR VOLTAGE MIN-MAX CALIBRATION

Combining (4) and (5) with (1)

$$P_n = \left[f(D_{\max}) \cdot f(D_{\min}) \right]^{\frac{1}{2}} \text{ (watt)} \quad (6)$$

If the calibration curve defined by equation (3) is used only in the linear range (corresponding to the square law response of crystal detectors when the input power is small), then $f(D_x) = k(D_x)$, and the calibration constant k is obtained from

$$k = \frac{V_x^2 R_o}{D} = \frac{P_L}{D} \quad \text{(watt/volt)} \quad (7)$$

Equation (6), may then be reduced to

$$P_n = k \left[D_{\max} \cdot D_{\min} \right]^{\frac{1}{2}} \text{ (watt)} \quad (8)$$

The elimination of R_o from the final equation is essential to permit the use of this approach for measuring net power in waveguide systems.

The slotted line calibration can also be used to determine the standing wave ratio S produced by the termination. From equations (4) and (5) we may develop the formula.

$$S = \frac{V_{\max}}{V_{\min}} = \sqrt{\frac{f(D_{\max}) R_o}{f(D_{\min}) R_o}} \quad (9)$$

For measurements within the square-law region of the detector this reduces to

$$S = \sqrt{\frac{D_{\max}}{D_{\min}}} \quad (10)$$

With this system, then, both the power and the VSWR of the load may be determined. Moreover, with relatively long slotted sections of transmission line it is possible to determine power flow at several half-wave intervals along the line. From this information it is possible to estimate the loss per unit length, and consequently the loss between the point at which the power is determined and the point of actual termination. Finally, the ratio of P_n/P_{in} may be found or defined in the previous section.

2.2.3 Calibrated Bridgewire Method

In this method an inert EED (with bridgewire exposed) terminates a coaxial line system as shown in Figure 2-4. A photocell or infrared detector is positioned near the bridgewire in a light-tight enclosure. RF power is supplied to the system, and the impedances are matched as in the other methods. From preceding discussions we know that the power measured by a calorimetric power meter at the firing switch is equal to the power dissipated in the components beyond the firing switch. This power is consumed in the impedance matching network, the lines leading into the firing chamber, and the EED itself.

In this method we are concerned with determination of power in the bridgewire only. We do this by using the photocell as an indicator of bridgewire temperature. The photocell is calibrated in terms of power by using a dc input, for which power computations are very simple. We then adjust the RF power in the bridgewire to give the same photocell reading as with dc power. The ratio of these two power inputs we call the system efficiency. Now when the instrumented bridgewire is removed and the test piece put in its place, we can use efficiency to determine what power setting is required at the system input to produce any specific power at the bridgewire. This procedure presupposes that the base loss in the squibs differs insignificantly from

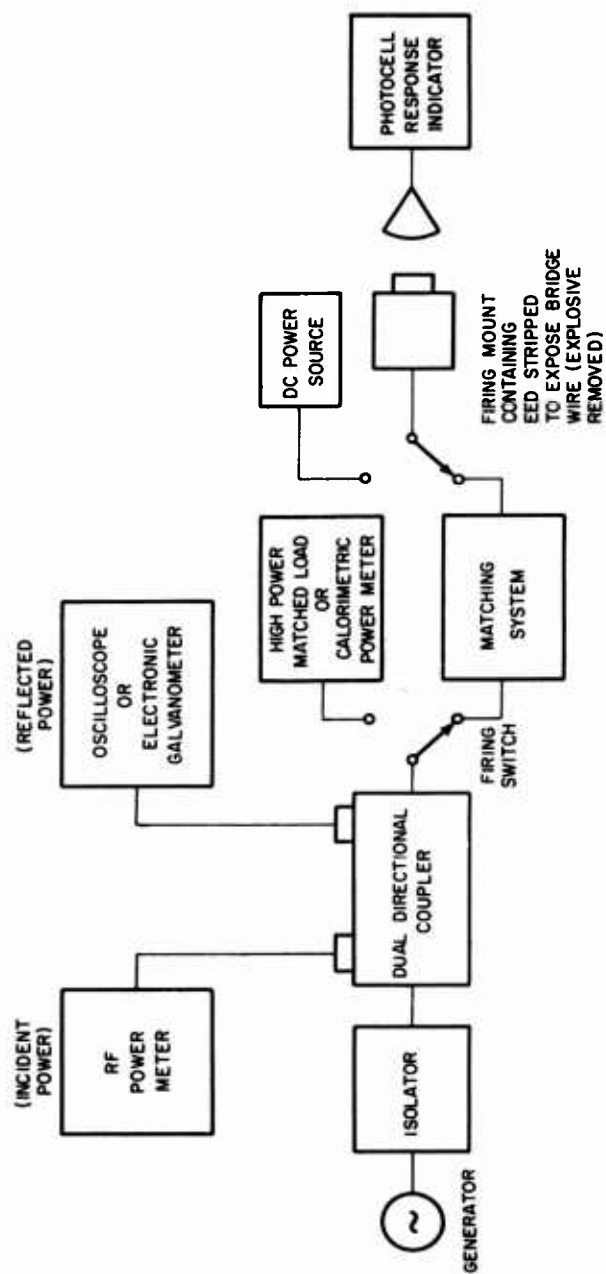

FIG. 2-4. BASIC ARRANGEMENT FOR FIRING SYSTEM CALIBRATION BY THE CALIBRATED BRIDGE WIRE METHOD

the calibrating unit, and that RF power and dc power produce similar thermal effects in the bridgewire, which is probably a valid assumption, at least at the lower frequencies.

2.3 Detailed Firing Systems

The following sections show in complete detail, each of the six RF firing systems employed at The Franklin Institute. Specific instruments called out are not necessarily the only ones that may be employed; it should be understood that the phrase, "or equivalent" follows each component specification.

2.3.1 Equipment Used at 5 to 30 Mc (CW)

The block diagram shown in Figure 2-5 applies to the following specific equipment.

- (1) RF Power Generator: Johnson Viking II Amateur Transmitter (modified); 0 to 100 w 5 to 30 Mc.
- (2) Fixed Power Attenuator: Resistive-T network; 6 db attenuation; forced air cooled; developed by The Franklin Institute.
- (3) Directional Couplers (2); M. C. Jones Model 263 dual coupler: 1000 w at 0.5 to 225 Mc.
- (4) Fixed Attenuator: Microlab Model AD-03N AD-06N, AD-10N, and AD-20N; 3, 6, 10 and 20 db attenuators; 15 w at dc to 4 Gc; (employed as necessary to obtain proper power level).
- (5) Power Indicator (forward power monitor): developed by The Franklin Institute.

Comprises Triplet Model 626 microammeter (200 microamp. 180 ohms) and switch-selected resistors.

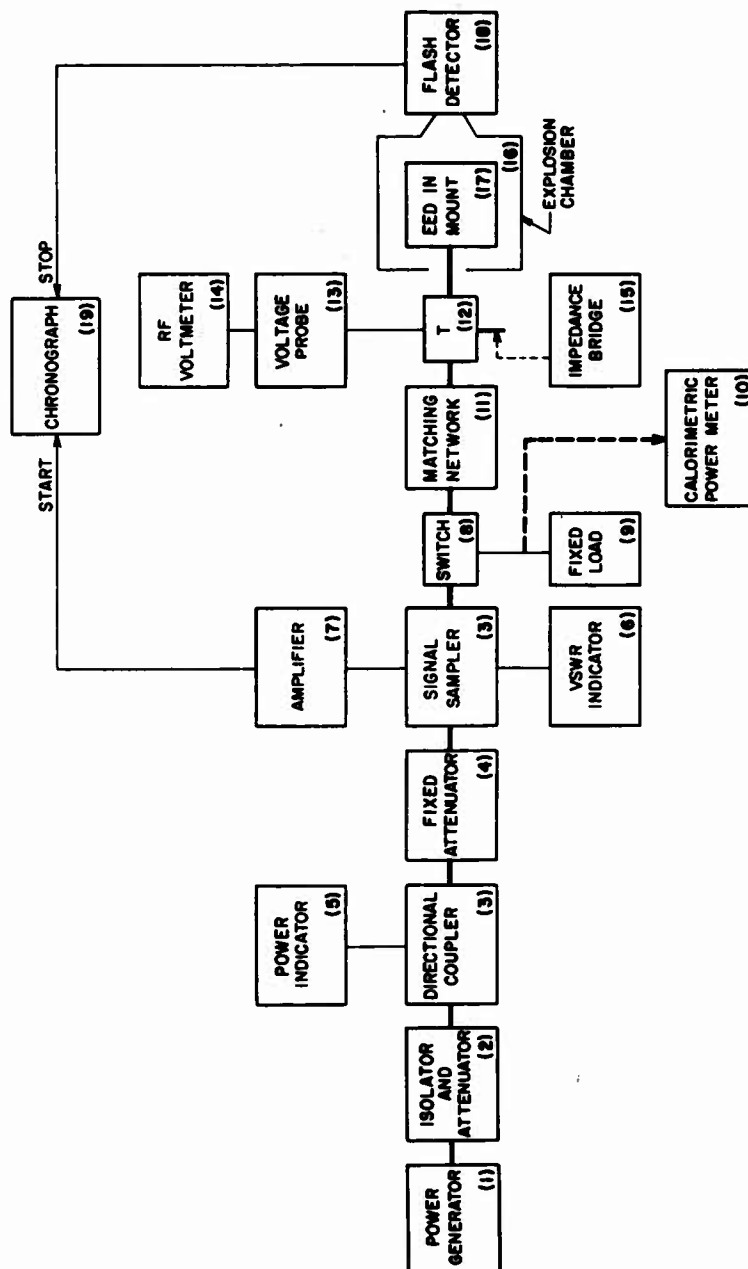

FIG. 2-3. FIRING SYSTEM, 5 TO 30Mc (CW)

- (6) VSWR Indicator (reflected power): KinTel Model 204A electronic galvanometer.
- (7) DC Amplifier (chronograph start): Tektronix Model 112. (as required to insure start).
- (8) RF Switch: Transco Model 11300; solenoid operated.
- (9) High Power Termination: Microlab Model TB-5MN, 50 ohm 10 w termination; Sierra Electronics Model 160-20 MN (20 watts).
- (10) Power Standard: Hewlett-Packard Model 434A calorimetric power meter; 10 mw to 10 w at dc to 12.4 Gc, with internal power source for calibration.
- (11) Impedance Matching Network: adjustable capacitive and inductive components in L and pi networks to achieve an impedance match between the EED and 50-ohm line. Developed by The Franklin Institute.
- (12) Coaxial Tee: General Radio Type 874-T coupling element.
- (13) Voltage Probe: Hewlett-Packard Type 411A-21B probe 500 Kc to 250 Mc (100:1 capacitive divider) to be used in conjunction with Model 411A RF millivoltmeter.
- (14) RF Millivoltmeter: Hewlett-Packard Model 411A millivoltmeter. 10 mv to 10 volts rms at .5 to 1000 Mc.
- (15) Impedance Bridge: General Radio Type 1606-A or 916A RF Bridge, 0.4 to 60 Mc; or GR-821-A twin Tee Bridge, 1-30 Mc; plus necessary accessories.
- (16) Firing Chamber: Steel chamber specially designed for testing electroexplosive devices (includes safety shields electrical interlocks, and ventilation system).
- (17) RF Mount: Special mounting fixtures are made for each electroexplosive device tested.

- (18) Flash Detector (chronograph stop): Developed by The Franklin Institute. A photo-multiplier tube is triggered by the light output of the electroexplosive device as it is initiated. The detector delivers a well defined pulse to the chronograph stop.
- (19) Chronograph: Beckman/Berkeley Model 7370R universal EPUT and timer.

2.3.2 Equipment Used at 250-500 Mc (CW)

The following equipment is used in the system shown in Figure 2-6

- (1) RF Power Generator: APQ-2 airborne jamming transmitter (modified); 0 to 12 w at 200 to 550 Mc.
- (2) Fixed Attenuators: Microlab Models AD-03N, AD-06N, AD-10N, AD-20N: 3, 6, 10 and 20 db attenuators (employed as necessary for proper power levels).
- (3) RF Switch: Transco Model 11300, solenoid operated.
- (4) High Power 50-ohm Termination: Microlab Model TB-5MN, 10 w, dc to 5 Gc, or Sierra Electronics Model 160-20 MN (20 watts).
- (5) Signal Detector (chronograph start): Microlab Model HXN-10 signal sampler (contains crystal detector).
- (6) Directional Couplers (incident and reflected power) Hewlett-Packard dual directional coupler Model 764D (216 to 450 Mc) 20 db nominal coupling.
- (7) RF Detector (incident power): Hewlett-Packard Model 477B thermistor mount; 0.1 to 10 mw at 10 to 10,000 Mc.
- (8) RF Detector (reflected power): Hewlett-Packard Model 420B crystal detector: 10 to 12,500 Mc.
- (9) Indicator (incident power): Hewlett-Packard Model 430C or 431B microwave power meter: 1 microwatt to 10 milliwatts.

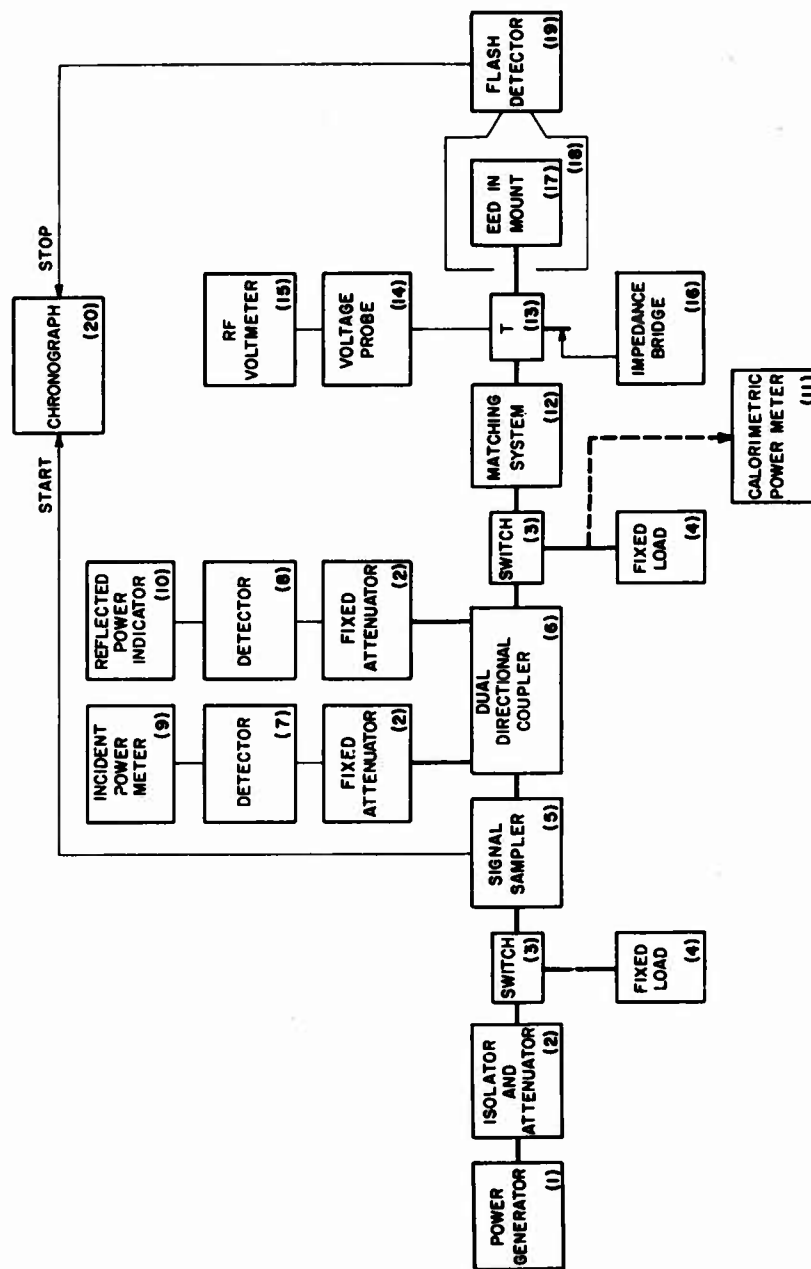

FIG. 2-5. FIRING SYSTEM, 250 TO 500 Mc (CW)

- (10) Indicator (reflected power): KinTel Model 204A electronic galvanometer.
- (11) Power Standard: Hewlett-Packard Model 434A calorimetric power meter: 10 mw to 10 w, at dc to 12.4 Gc, with power source for calibration.
- (12) Impedance Matching System: Microlab Model SL-03N stub stretcher; 250 to 10,000 Mc.
- (13) Coaxial Tee: General Radio Type 874-T coupling element.
- (14) Voltage Probe: Hewlett-Packard Type 411A-21B probe (100: 1 capacitive) divider to be used in conjunction with Model 411A RF Millivoltmeter. 500 Kc to 250 Mc.
- (15) RF Millivoltmeter: Hewlett-Packard Model 411A millivoltmeter. 10 mv to 10 vac rms, at .5 to 1000 Mc.
- (16) Impedance Bridge: General Radio Type 1607A transfer function and immittance bridge 25-1500 Mc.
- (17) RF Mount: Special mounting fixtures are made for each electroexplosive device tested.
- (18) Firing Chamber: Steel chamber specially designed for testing electroexplosive devices (include safety shields, electrical interlocks, and ventilation system).
- (19) Flash detector (chronograph stop): developed by The Franklin Institute. It comprises a photo-multiplier tube which is triggered by the light output of the electro-explosive device as it is initiated. The detector delivers a well-defined pulse to the chronograph stop circuit.
- (20) Chronograph: Beckman/Berkeley Model 7370R universal EPUT and timer.

2.3.3 Equipment used at 400 to 1350 Mc (CW)

The firing system shown in Figure 2-7 is defined in detail by the following.

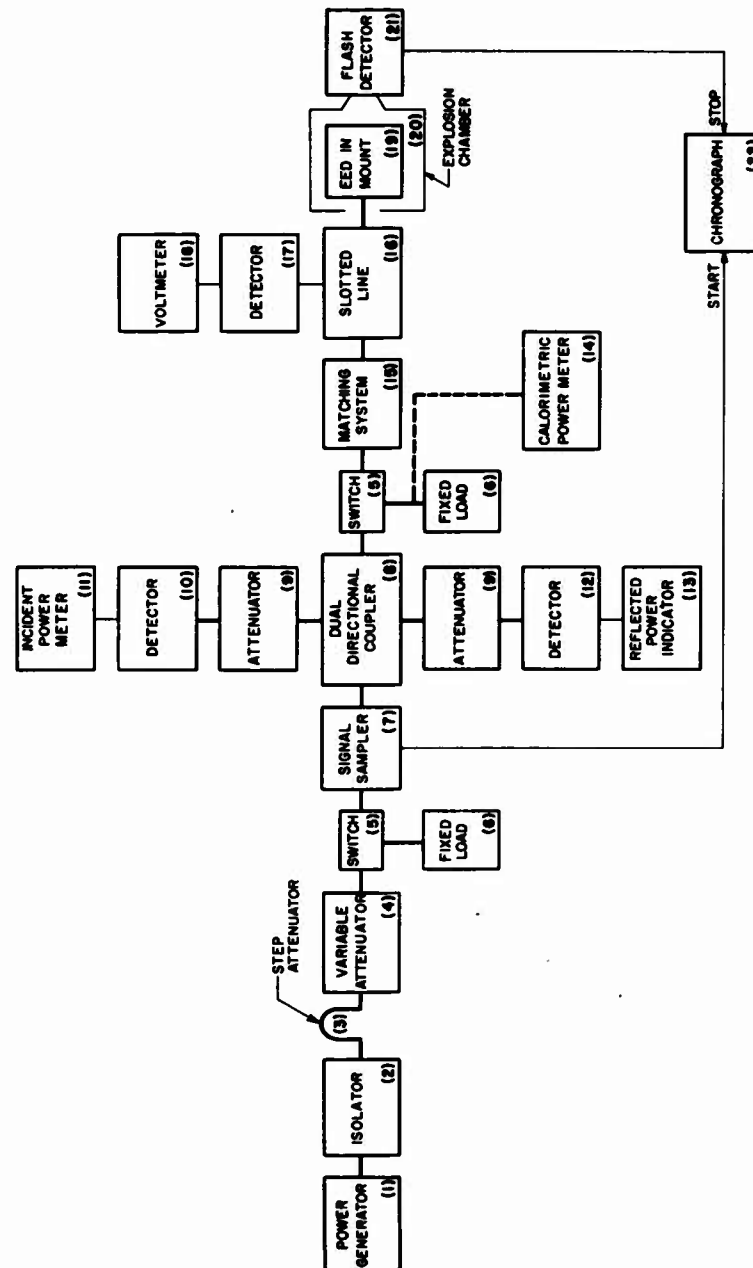

FIG. 2-7. FIRING SYSTEM, 400 TO 1550 Mc (CW)

- (1) RF Power Generator: Convert T-147/APT-8 radar transmitter 10-50 watt 400 to 1500 Mc.
- (2) Isolator: Sperry Microline Model D4412-7, .95 to 2.35 Gc, 10 db isolation use in stated frequency range; for lower frequency use suitable attenuator.
- (3) Fixed Attenuator: Sections of RG-87/U coaxial transmission line (length of the line depends on power output range needed for test).
- (4) Variable Attenuator: Merrimac Model AU-10 variable coaxial attenuator. 300 to 5000 Mc 25 watts dissipation. 10 to 55 db.
- (5) RF Coaxial Switch: Transco Model 11300 solenoid operated.
- (6) High Power 50-ohm Termination: Microlab Model TI-5MN (150 watts); Sierra Electronics Model 160-20 MN (20 watts); M. C. Jones Model 603MN (20 watts)
- (7) Signal Sampler (chronograph start): Microlab Model HX-10N 50 to 10,000 Mc.
- (8) Dual Directional Coupler: Hewlett-Packard Model 766D (940-1975 Mc) or Model 767D (1.9-4.0 Gc) or Narda Model 3022 (1-5 Gc).
- (9) Fixed Attenuators: Microlab Models AD-03N, AD-06N AD-10N, AD-20N: 3, 6, 10 and 20 db Attenuators (employed as necessary to reduce power into detectors).
- (10) RF Detector (incident power): Hewlett-Packard Model 477B thermistor mount; 0.1 mw at 10 to 10,000 Mc.
- (11) Indicator (incident power): Hewlett-Packard Model 430C or 341 microwave power meter; 1 microwatt to 10 milliwatts.
- (12) RF Detector (reflected power): Hewlett-Packard Model 420B crystal detectors; 10 to 12,500 Mc.
- (13) Indicator (reflected power): KinTel Model 204A electronic galvanometer.

- (14) Power Standard: Hewlett-Packard Model 434A calorimetric power meter; 10 mw to 10 w at dc to 12.4 Gc, with internal power source for calibration.
- (15) Impedance Matching Network: Microlab Model SL-03N stub stretcher; 300 to 10,000 Mc.
- (16) Slotted Line (coaxial): General Radio Model 874-LBA (300-5000 Mc) or Hewlett-Packard Model 805C (.5-4.0 Gc).
- (17) Crystal Detector: IN21B or equivalent.
- (18) Meter: Hewlett-Packard Model 425A dc microvolt-ammeter (10 microvolts to 1 volt; 10 picoamperes to 3 milliamperes).
- (19) RF Mount: Special mounting fix twins are made for each electroexplosive device tested.
- (20) Firing Chamber: Steel chamber specially designed for testing electroexplosive devices (includes safety shields, electrical interlocks and ventilation systems).
- (21) Flash Detector (chronograph stop): Developed by The Franklin Institute. It comprises a photomultiplier tube which is triggered by the light output of the EED as it is initiated. The detector delivers a well-defined pulse to the chronograph start circuit.
- (22) Chronograph: Beckman/Berkeley Model 737OR Universal EPUT and Timer.

2.3.4 Equipment Used at 2500 to 3500 Mc (CW or Pulsed)

Equipment shown in Figure 2-8 is as follows:

- (1) Signal Source. (one of the following three).
 - (1A) RF Power Generator; AN/CPN-6 Radar beacon transmitter. Average power output 80 watts; maximum duty cycle .001 and maximum pulse width 2 μ seconds; 2700 to 2740 Mc.
 - (1B) Microwave CW source; FIL 421-6115: Power output 100 watts; 2295 to 3638 Mc.

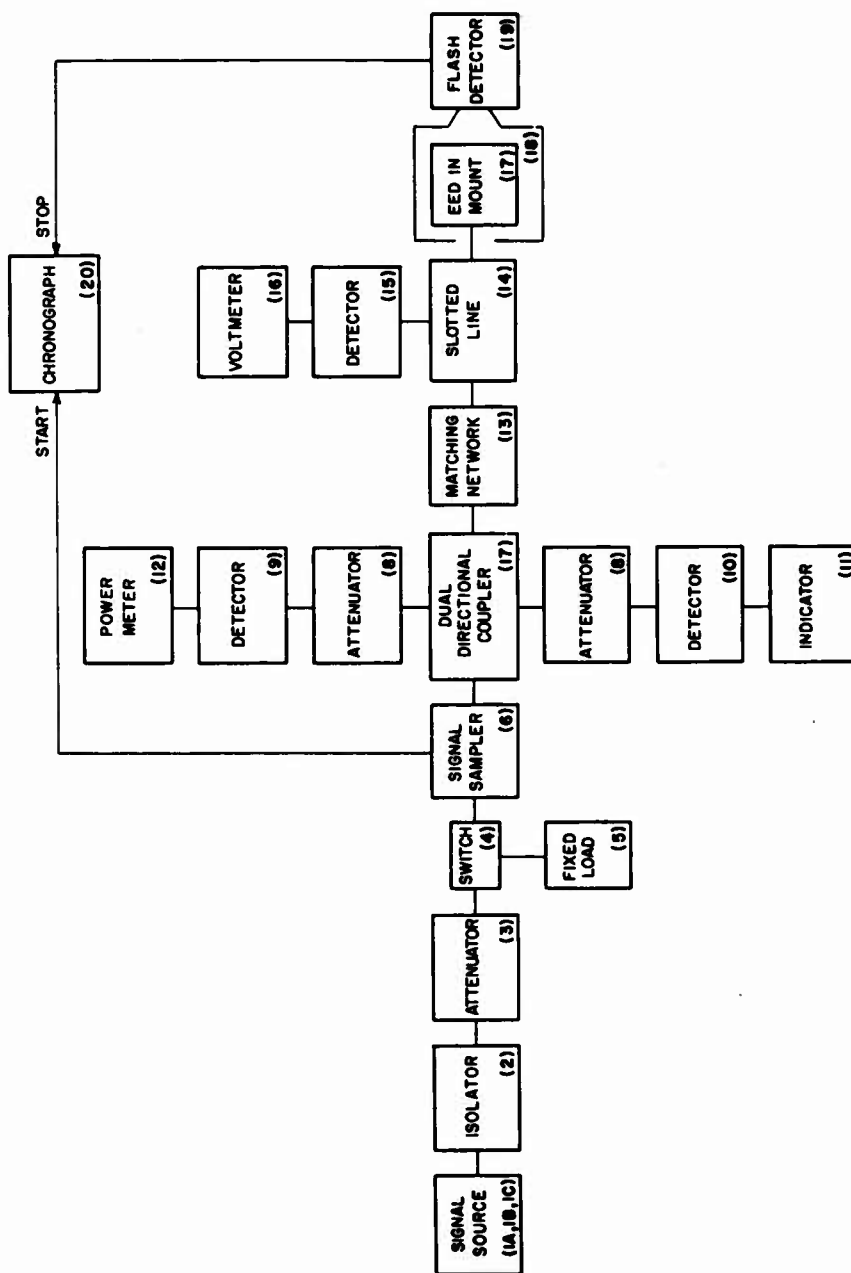

FIG. 2-8. FRINGING SYSTEM, 2500 TO 3500Mc (CW OR PULSED)

- (1C) General Radio Klystron Power Supply #1201A: Oscillator type 1220A, Klystron #726C; power output 100 Milliwatts; 2700 to 2960 Mc.
- (2) Isolator: Raytheon, ISH14, 2700 to 3100 Mc
- (3) Attneuator
- (3A) Fixed: 15 to 20 db; RRD Type 171
- (3B) Variable: PRD Type 171 waveguide (for pulsed power). 0-40 db.
- (4) RF waveguide Switch, Bogart S-4421-C
- (5) Coaxial 50-ohm termination: ISL 366 100 watts
- (6) Signal Detector (chronograph start): Mic. Model HX-10N, Signal Sampler; 50 to 10,000 Mc.
- (7) Directional Coupler: NARDA Model 1034
- (8) Fixed Attenuators: Microlab Models AD-03N, AD-06N, AD-10N, AD-20N; 3, 6, 10 and 20 db respectively. Used as necessary to reduce power into detectors.
- (9) RF Detector (incident power): Hewlett-Packard Model 478A thermistor mount; 0.1 mw at 10 to 10,000 Mc.
- (10) RF Detector (reflected power): Hewlett-Packard Model 420B crystal detector; 10 to 12,500 Mc.
- (11) Indicator (reflected power): KinTel Model 204A electronic galvanometer.
- (12) Indicator (incident power): Hewlett-Packard Model 431B microwave power meter; 1 microwatt to 10 mw.
- (13) Impedance Matching Network: Demornay-Binardi Model DBL-979; 3 Gc E-H tuner.
- (14) Slotted Line: Hewlett-Packard Model S801A waveguide slotted section.

- (15) Variable Crystal-Detector Probe: Has IN26 Crystal, Starrett 263 micrometer drive.
- (16) Meter; Hewlett-Packard Model 425A dc microvolt-ammeter (10 microvolts to 1 volt; 10 picoamperes to 3 milliamperes.
- (17) RF Mount: Special mounting fixtures are made for each type of electroexplosive tested.
- (18) Firing Chamber: Steel chamber specially designed for testing electroexplosive devices (includes safety shields, electrical interlocks, ventilation system, etc.).
- (19) Flash Detector (chronograph stop): Developed by The Franklin Institute. It employs a photo-multiplier tube which is triggered by the light output of the electroexplosive device as it is initiated.
- (20) Chronograph: Beckman/Berkeley Model 737OR Universal EPUT and timer.

2.3.5 Equipment Used at 4500 and 5500 Mc (CW or Pulsed)

Figure 2-9 employs the following equipment.

(1) Signal Sources:

(1A) RF Power Generator: AN/CPN-6 radar beacon transmitter. Average output power 50-80 watts. Maximum duty cycle .001 and maximum pulse width 2 μ seconds; 5386 - 5420 Mc.

(1B) Microwave CW power source FIL 421-6115 power output 100 watts. 4955 to 6310 Mc.

(1C) PRD Klystron Power Supply 809A; or General Radio Klystron Power Supply #1201A OSC. Type 1220A Klystron, Raytheon 6115. Power output 100 milliwatts. 5100 - 5900 Mc used with the above Klystron.

(2) Isolator for Source

(2A) Isolator: Raytheon Model 1CH1 5250-5750 Mc.

(2B) PRD Attenuator: Type 162B 40 db attenuation.

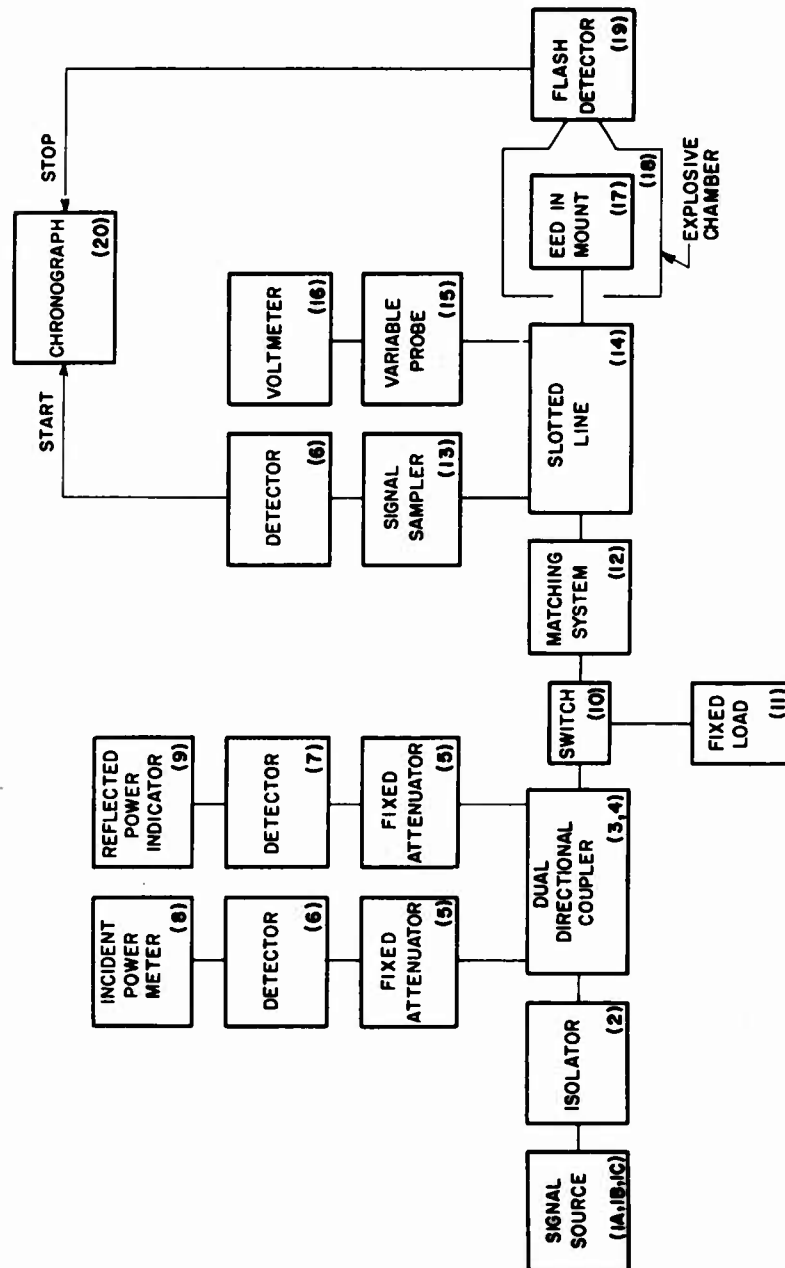

FIG. 2-9. FIRING SYSTEM, 4500 TO 5500 Mc (CW OR PULSED)

THE FRANKLIN INSTITUTE • *Laboratories for Research and Development*

IM-B1980-2

- (3)&(4) Dual Directional Coupler: Demornay-Bonardi Model DBK-642 cross guide coupler: 20 db nominal coupling at 5 Gc.
- (5) Fixed Attenuators: Weinchel Engineering Model 210-10; 10 db attenuation at 1 to 10 Gc (used as necessary to reduce power to RF detectors).
- (6) RF Detector (incident power): Hewlett-Packard Model 478A Thermistor Mount; 10 mw at 10 Mc to 10 Gc.
- (7) RF Detector (reflected power): Hewlett-Packard Model 431B crystal detector; 10 Mc to 12.5 Gc.
- (8) Indicator (incident power): Hewlett-Packard Model 431B microwave power meter. 1 microwatt to 10 milliwatts.
- (9) Indicator (reflected power): KinTel Model 204A electronic galvanometer.
- (10) RF Switch (waveguide): Quantatron Inc. WS-03621 waveguide switch, solenoid operated, 3.95 to 5.85 Gc.
- (11) High Power Termination: Demornay-Bonardi Model DBK-746 700 watts at 3.95 to 5.85 Gc.
- (12) Impedance matching network: Demornay-Bonardi Model DBK-979 E-H tuner: 3.95 to 5.85 Gc.
- (13) Signal Detector (chronograph start): HP type 444A untuned probe.
- (14) Slotted-Line: Hewlett-Packard Model C-810-B slotted section used with Model 809B probe carriage.
- (15) Variable Crystal-Detector Probe: has IN26 crystal, Starrett #263 micrometer.
- (16) Meter: Hewlett-Packard Model 425A dc microvolt-ammeter (10 microvolts to 1 volt; 10 picoamperes to 3 milliamperes).
- (17) RF Mount: Special waveguide mount to terminate waveguide with EED.
- (18) Firing Chamber: Steel chamber specially designed for testing EED's (includes safety shields, electrical interlock and ventilation system).

- (19) Flash-Detector (chronograph stop): Developed by The Franklin Institute. It employs a photo-multiplier tube which is triggered by the light output of the EED, as it is initiated.
- (20) Chronograph: Beckman/Berkeley Model 7370R Universal EPUT and timer.

2.3.6 Equipment Used at 8500 to 10,000 Mc (CW or Pulsed)

Figure 2-10 is completed by use of the following equipment.

- (1) Signal Source
 - (1A) RF Power Generator: AN/CPN-6 radar beacon transmitter. Average output power 50 - 64 watts. Max duty cycle .001 and max. pulse width 2 seconds. Frequency 8500 to 9600 Mc.
 - (1B) Microwave CW Power Source FIL 421-6115. Power output 93.0 watts mag. freq. range 8725 to 10,545 Mc.
 - (1C) PRD Klystron Power Supply Type 809A or General Radio Klystron Power Supply #1201A OSC. Type 1220A Klystron Raytheon 8500-9660 Mc.
- (2) Isolator: Uniline Mod. 8696.
- (3) Variable Attenuator
- (4)&(5) Directional Couplers (incident (4) and reflected (5) power): Two Hewlett-Packard Model X752D multihole waveguide directional couplers; 20 db nominal coupling at 8.2 to 12.4 Gc.
- (6) Fixed Attenuators: Waveguide Narda Model 720-10; 10 db attenuation at 8.2 to 12.4 Gc (Used as necessary to reduce power to RF detectors). Coaxial attenuators, Weinschel Eng. Model 210-20 Freq. 2-10 Gc, 10-50 db.
- (7) RF Detector (incident power): Hewlett-Packard Thermistor Mount, Model X486A. Hewlett-Packard Thermistor Mount Model 478A, or 477B with Narda Model 601A waveguide to coaxial adaptor.

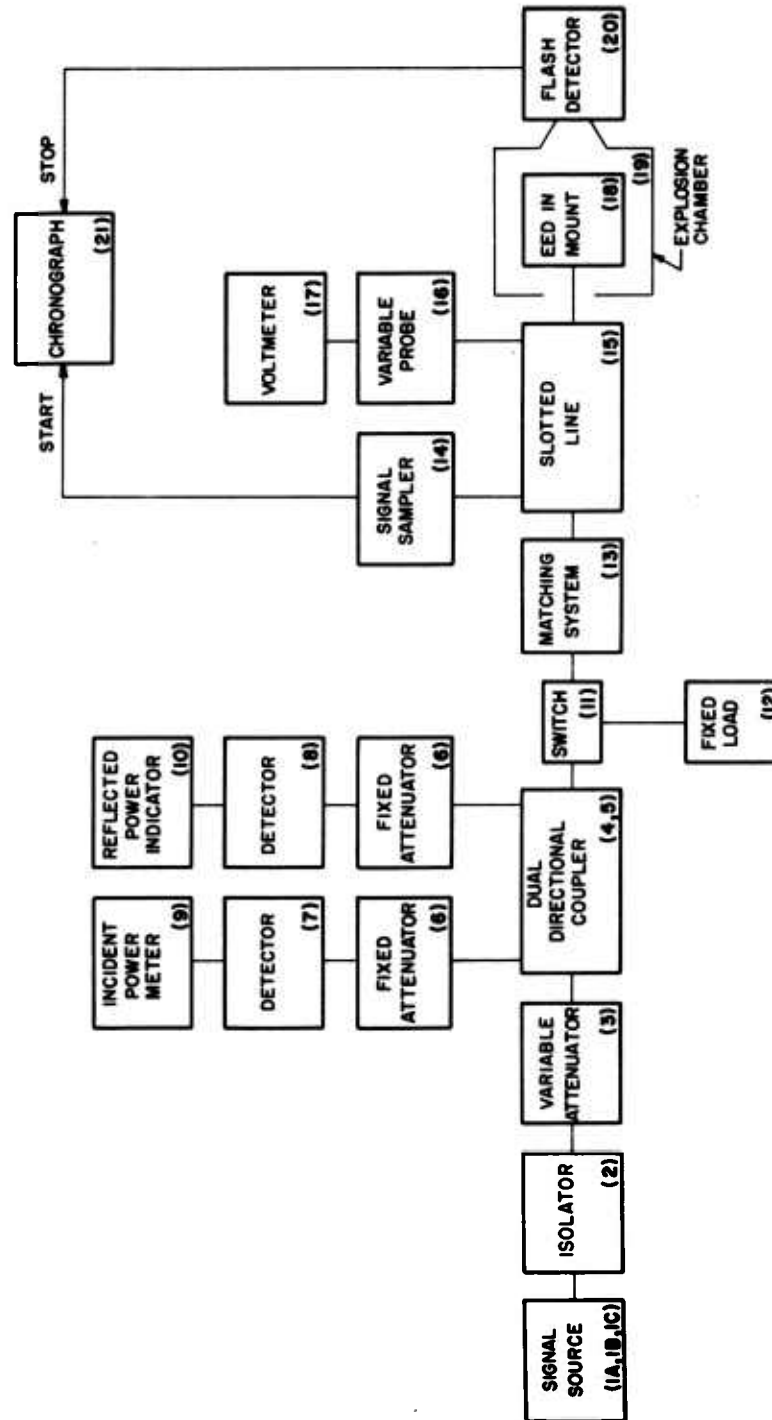

FIG. 2-10. FIRING SYSTEM, 8500 TO 10,000Mc (CW OR PULSED)

- (8) RF Detector (reflected power):
 - (8A) Hewlett-Packard Model 420B crystal detector: 10 Mc to 12.5 Gc; with Narda Model 601B Waveguide-to-coaxial adaptor.
 - (8B) RF Detector: Microlab XA-20; 10 Mc to 12.5 Gc.
- (9) Indicator (incident power): Hewlett-Packard Model 431B microwave power meter, 1 microwatt to 10 milliwatts.
- (10) Indicator (reflected power): KinTel Model 204A electronic galvanometer.
- (11) RF Switch (waveguide): FXR Model X641AE waveguide switch, solenoid operated, for 8.2 to 12.4 Gc.
- (12) High Power Termination: DA-22/U175 waveguide termination; 8.2 to 12.4 Gc.
- (13) Impedance Matching Network: Hewlett-Packard Model X880A E-H waveguide tuner: 8.2 to 12.4 Gc.
- (14) Signal Detector (chronograph start): HP Type 44A Untuned Probe.
- (15) Slotted-line: Hewlett-Packard Model X810B slotted section used with Model 809 probe carriage.
- (16) Variable Crystal-Detector Probe: Fits into Hewlett-Packard 809B probe carriage; has IN26 crystal and Starrett No. 263 micrometer head.
- (17) Meter: Hewlett-Packard Model 425A dc microvolt-ammeter (10 microvolts to 1 volt; 10 picoamperes to 3 milliamperes).
- (18) RF Mount: Special waveguide mount to terminate waveguide with EED.
- (19) Firing Chamber: Steel chamber specially designed for testing EEDs. (Includes safety shields electrical interlock and ventilation system).

LM-B1980-2

- (20) Flash-Detector (chronograph stop): Developed by The Franklin Institute. It employs a photo-multiplier tube, triggered by the high output of the EED as it is initiated.
- (21) Chronograph: Beckman/Berkeley Model 737OR Universal EPUT and timer.

3. PROTECTIVE SCHEME EVALUATIONS

Components designed to provide protection from RF energy may take many forms, but the most popular is that which is typified by the two-port four-terminal network. Multi-port networks present special problems, and proper evaluation can be made only after the nature of the proposed RF safety system has been examined. Accordingly, no attempt will be made to document possible test procedures for special devices.

For the general insertion-type protective scheme a measure of the decrease of signal, as shown by the relationship of output to input power is the parameter of primary concern. If the device is proposed for use in any unspecified system it is imperative that its "worst case" attenuation be determined. Since neither input nor output conditions can be specified in such use the only loss that can be assured is the minimum or worst case loss.

In many cases a protective scheme is designed for a specific termination or family of terminations, and only the input is uncertain. For these a terminated power loss determination would be acceptable.

3.1 Determination of Worst Case Attenuation

The worst case, or minimum loss, for any four-terminal system can be determined in one of two ways. At the lower frequencies, where impedances have meaning, a model dissymmetrical network is constructed and analyzed. Evaluations of α_{wc} at higher frequencies is more easily done by employing a matched attenuation measuring system.

3.1.1 Dissymmetrical Network Model Analyses

From measurements of input impedance made in each direction for a component, with two known terminations (usually open and short circuit) it is possible to construct the T-network shown in Figure 3-1.

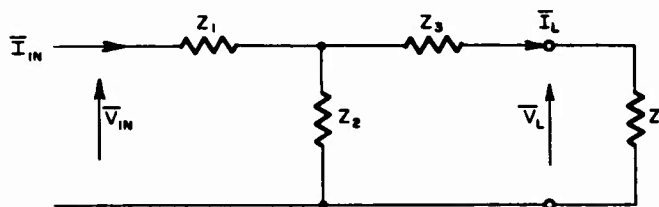

FIG. 3-1. DISSYMETRICAL T NETWORK AND LOAD

We next find the terminating impedance which will maximize the ratio P_L/P_{in} and thus minimize the attenuation provided. (P_L is power taken by the terminating impedance.) The worst case impedance Z_{wc} will be of the form

$$Z_{wc} = x + j y$$

$$x = \frac{1}{2(G + K)} \sqrt{4R(G + K) - V^2}$$

$$y = \frac{-V}{2(G + K)}$$

where G and K result from substitution made for the network impedance earlier in the derivation as follows⁽¹⁾

$$Z_1 = G + j H; Z_2 = K + j L; Z_3 = P + j Q$$

Having performed this determination, α_{wc} is determined from

$$\alpha_{wc} = 10 \log_{10} \frac{P_L}{P_{in}}$$

(1) For a more complete derivation of this expression see Franklin Institute Progress Report P-B1980-4, "Development of Broad-Band Electromagnetic Absorbers for Electro-Explosive Devices" by P. F. Mohrbach, R. F. Wood, October 1962, Naval Weapons Laboratory Contract No. N178-8087.

$$\frac{P_L}{P_{in}} = \frac{|Z_2|^2 \operatorname{Re} \{Z_L\}}{\operatorname{Re} \{ [Z_1 Z_2 + Z_1 Z_3 + Z_2 Z_3 + Z_L (Z_1 + Z_2)] [Z_2 + Z_3 + Z_L] \}}$$

Admittedly, these determinations are somewhat difficult to manage. It is recommended that use be made of an electronic computer to expedite these analyses.

3.1.2 Matched Attenuation Determination

The preferred system for measuring dissipative attenuation at higher frequencies employs the principle of IF series substitution, in which a linear detector is used to change the frequency of the RF signal to a fixed intermediate frequency after it passes through the network being measured. This is done so that a fixed-frequency calibrated attenuator can be designed. The use of an intermediate frequency also allows the use of a high-gain low-noise tuned amplifier ahead of the output meter to increase the sensitivity of the meter; this makes possible the measurement of attenuation greater than 70 db without applying unduly high RF power to the system.

Figure 3-2 shows a block diagram of the system and lists all of the component parts. Their functions are described below.

1. The RF generator should be capable of providing at least 100 mw of CW power at the test frequency. We use three General Radio Unit RF oscillators to cover the frequency range from 120 to 2000 Mc.
2. The Variable Attenuator provides a means of adjusting the generator output level from zero to about 20 db while maintaining a characteristic impedance of 50 ohms.
3. A 10 db pad isolates the generator from the system and helps to maintain a constant output power even though the impedance beyond the attenuator is changing.
4. The dual directional coupler, crystal detectors and micro-voltmeter are used to monitor either the incident or reflected transmission line power ahead of the first single stub tuner.

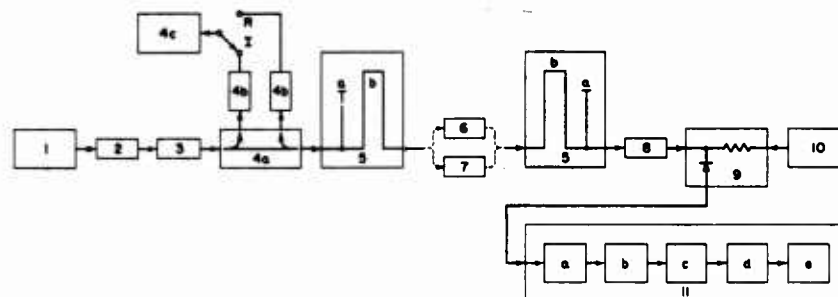

FIG. 3-2. IF SUBSTITUTION METHOD FOR MEASURING DISSIPATIVE ATTENUATION

SPECIFIC EQUIPMENT USED AT FRANKLIN INSTITUTE FOR
DISSIPATIVE ATTENUATION MEASUREMENT SYSTEM
(IF Substitution Method)

- | | |
|--|--|
| <p>1. RF Generator: General Radio
Model 1208B, 65 - 500 Mc
1209B, 250 - 950 Mc
1218A, 900 - 2000 Mc</p> <p>2. Variable Attenuator (0-25 db): Radar Design
Corp. Model 1196</p> <p>3. Fixed Attenuator (10 db): General Radio
Type 874-G10</p> <p>4. Power Monitor:
a. Directional Coupler:
Narda Model 3020, Model 3022
b. Crystal Detector (2):
Hewlett-Packard Model 421A
c. Microvoltmeter:
KinTel Model 204A</p> | <p>5. Single Stub Tuners (2)
a. Stub tuner: Microlab Model S1-02N
b. Stub stretcher: Microlab Model ST-05N</p> <p>6. Fixed Attenuator (10 db): General Radio
Type 874-G10</p> <p>7. Four Terminal "Unknown" Network</p> <p>8. Fixed Attenuator (10 db): General Radio
Type 874-G10</p> <p>9. Crystal Mixer: General Radio Model 874-MR</p> <p>10. Local Oscillator: Same as No. 1</p> <p>11. IF Amplifier: General Radio Model 1216-A
a. Pre-amplifier d. detector
b. Step Attenuator e. Output meter
c. Amplifier</p> |
|--|--|

5. Two single stub tuners are used, one on either side of the network being measured. Each consists of an adjustable short circuited stub and a line stretcher. The network under evaluation is inserted between the stretcher sections of the tuners. An impedance match between the system's 50-ohm transmission line and the input and output impedances of the network is made by adjustment of the tuner components. A single stub tuner is theoretically capable of matching any impedance to 50 ohms. Chain drive traversing mechanisms, mounted on a rigid frame, allow us to adjust the tuner components easily to within a fraction of a centimeter.

6. A second 10 db pad is used for the initial system calibration before the lossy network is inserted. Since its attenuation influences the measurement, it must be accurately calibrated.

7. The network to be measured should be placed in a shielded container with either type "N" or General Radio Type 874 connectors at opposite ends. Lossy materials are placed between the inner and outer conductors of a section of rigid transmission line, so as to fill the space between the conductors.

8. Another 10 db pad isolates the dual directional coupler (No. 4) from the local oscillator which follows. Without it, local oscillator power would leak back through the signal circuit and interfere with the incident and reflected power measurements at the directional couplers. The pad also appears as a 50 ohm termination for the second tuner.

9. A crystal mixer is used to create the intermediate frequency used in measurements. Signals from the RF generator and a local oscillator are applied to the mixer. The local oscillator is set for a frequency either 30 Mc above or 30 Mc below the RF generator. An output signal of 30 Mc is obtained whose amplitude is directly proportional to the RF generator, provided that the local oscillator output is sufficient for a crystal current between 0.2 and 5 ma. A means of checking the crystal current is described in 11, below.

10. The local oscillator (see 9 above) should have at least 100 mw of output power at a frequency equal to the RF generator frequency \pm 30 Mc.

11. The IF amplifier comprises a 30 Mc tuned amplifier, a calibrated step attenuator between the first and second stages of the amplifier, and a detector and output meter. The upper scale of the meter is calibrated from 1 to 10 db. A switch connects the output meter directly to the crystal mixer, to indicate the crystal current. The meter should read between 5 and 100 (lower scale) for good mixer linearity. If it should read outside this range an adjustment of the local oscillator output level is required.

3.2 Procedure for Making Dissipative Attenuation Measurements

The oscillators and the IF amplifier should have a 5 to 10 minute warm-up. A 10 db pad is connected between the tuners. The RF generator is set to the desired test frequency and the local oscillator 30 Mc above or below that frequency. The exact setting of the local oscillator is made by obtaining a maximum deflection of the output meter. Should the meter be driven off scale the step attenuator can be adjusted to a position where an on-scale reading is obtained. The dc mixer current is checked by setting the meter switch to the proper position. For fundamental local oscillator operation a reading of from 5 to 100 (lower scale) is acceptable. If the reading is out of this range an adjustment of the local oscillator output level is necessary.

The 10 db pad is left between the tuners while setting the input power (P_i). This is done to make tuner adjustments easier. The 10 db pad isolates the two tuners so that each tuner is connected to approximately 50 ohms impedance. For a single stub tuner to match 50 ohms, all that is required is that the short circuited stubs be set a quarter-wavelength away from the transmission line. The line stretcher length can be changed without affecting this match. When a network having arbitrary terminal impedances is inserted between the tuners, however, both the stub and stretcher parts of the tuner must be simultaneously adjusted to obtain a maximum output. This must be done carefully, as the accuracy of the measurement depends on a maximum power transfer through the network.

A step by step procedure for making dissipative attenuation measurement follows. Before final adjustments are made, equipment must have had at least ten minutes warm-up.

1. Insert the 10 db pad into the system.
2. Set the RF generator to the desired test frequency.
3. Set the local oscillator to the test frequency \pm 30 db. (The exact setting is that which gives maximum output deflection). The output meter switch should be on the IF position and the step attenuator set to a position which will produce an on-scale indication.
4. The tuners are adjusted for a maximum output meter indication.
5. The incident power level is set with the variable attenuator for a convenient indication on the microvoltmeter. This setting is recorded.
6. The local oscillator is set for a peak output meter reading.
7. The sum of the attenuation values of the step attenuator, output meter, and 10 db pad is recorded.
8. The 10 db pad is removed from the system and the network to be measured is inserted in its place.
9. The tuners are carefully adjusted, one at a time, for a maximum output meter indication, resetting the step attenuator as necessary.
10. The incident power indication on the microvoltmeter should be the same as in step 5. If it differs, an adjustment of the variable attenuator is required.
11. The local oscillator is again adjusted for a peak output meter reading.
12. The sum of the attenuation readings at the step attenuator and the output meter is recorded.
13. The difference between the attenuations of steps 7 and 12 is equal to the dissipative attenuation of the network.

Note:

Step No. 7 ends the initial calibration of the system. While several measurements can be made for a simple calibration it is advisable that these steps be repeated often as changes in the microvoltmeter, crystal mixer, and IF amplifier could affect the calibration. The initial calibration must be repeated if the frequency is changed.

3.3 Terminated Power Loss Measurements

Any terminated four terminal network containing dissipative elements will have associated with it a unique minimum power loss characteristic dependent upon the parameters of the specific network. Neither an attenuation constant nor an insertion loss ratio will clearly define this characteristic, but instead a network constant, "Terminated Power Loss" (TPL) must be defined.

If P_n represents the amount of power dissipated by the total network including the termination and P_o is the amount of the power dissipated by the termination or load, then the Terminated Power Loss is given by:

$$TPL = 10 \log_{10} \frac{P_n}{P_o} \quad (\text{db}) \quad (11)$$

Terminated Power Loss Ratio (TPLR) is simply $\frac{P_n}{P_o}$. For the network shown in Figure 3.3, the complex power may be characterized by the product $\bar{E} \bar{I}^*$. The power dissipated by the total network will be $\bar{E} \bar{I} \cos \theta$ where θ is the phase angle of the network's

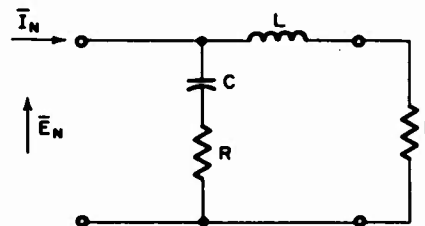

FIG. 3-3 BASIC DISSIPATIVE NETWORK

input impedance. However, P_n may be equally well determined by summing the power dissipated by both R and D. If D is taken as the termination then,

$$\text{TPLR} = \frac{P_R + P_D}{P_D} = 1 + \frac{P_R}{P_D} \quad (12)$$

The power measurements needed for this determination are made by classical means, or those discussed in Section 2.2 as required.

ACKNOWLEDGEMENTS

The systems and procedures described represent the result of a continuing effort over several years. The effort, in general, continues for other sponsors with frequent improvements of both techniques and equipments. (Changes are being contemplated as we prepare this document). We therefore wish to acknowledge the support of many other sponsors as well as the entire staff of the Applied Physics Laboratory. However, the more recent refinements of systems and techniques as described herein must be credited to the special efforts of George H. McKay, Ramie H. Thompson, and John P. Warren.

Paul F. Mohrbach

Paul F. Mohrbach
Group Leader

Very truly yours,

Norman P. Faunce

Norman P. Faunce
Project Engineer

Approved by

E. E. Hannum

E. E. Hannum, Manager
Applied Physics Laboratory

LM-B1980-2

APPENDIX

A-1 Statistical Techniques

There are two statistical techniques commonly used in determining the RF sensitivity of electroexplosive devices; the Bruceton analysis and Probit analysis. A detailed description of these are beyond the scope of this brief summary. Those who want more information should refer to the original source.

A-1.1 Bruceton Analysis

One method of determining the RF sensitivity of an electro-explosive device at a specific frequency consists of attempting to initiate a quantity of samples selected at random at one of several selected power levels according to a systematic procedure which, with the associated statistical computations, is known as the Bruceton analysis. The power levels chosen for a test are selected in the following way. The lowest power level should fall above the no-fire level for the device being evaluated and the highest power level should fall below the all-fire power level. For greatest validity, a test should utilize from three to six test levels and forty or more individual samples should be expended. The spacing between succeeding power levels is a constant lograithmic interval, since the sensitivity distribution of electroexplosive devices must be normalized before a Bruceton analysis can be applied. Before the evaluation test is begun, several devices must be expended to determine the approximate no-fire, mean, and all-fire power levels used in establishing the testing levels.

Prior to testing each device a small percentage of the test power (usually 5 to 10%) is applied, and the impedance matching networks are adjusted for best matching. Once an impedance match is obtained (reflected power less than 5% of incident power), the test is performed at the level closest to the mean firing level. If the device does not function, the second sample is tested at the next higher level. If it does function, the second sample is tested at the next lower level. Each succeeding one is tested according to the same rule. A function, or "fire", is indicated on part one of the test data sheets (Fig. A-1) by an "X"; while a nonfunction is indicated by an "O". Non-fires are not used again in the same test since their sensitivity may have been changed during the test, and to use them at other levels may yield erroneous results.

With the data obtained from a Bruceton test, we are able to calculate the mean (m) or 50 percent firing level, and the standard deviation (σ) by applying equations given in part two of the standard Bruceton data record sheet. Further computation (part three) yields the extreme probabilities such as the 99.9% and the 0.1% levels. These are usually expressed with 90% confidence intervals included.

A-1.2 Probit Analysis

Probit analysis is a means of transforming quantal data into a variable form. This enables the results to be expressed in terms of a mean and a standard deviation, rather than be limited to a percentage of fires.

Basically it calls for firing groups of detonators at several levels. These levels should be between the no-fire point and the all-fire point. Table A-1 represents data from a typical Probit test.

Table A-1

FIRING TEST PROBIT ANALYSIS

	<u>400 mw</u>	<u>430 mw</u>	<u>450 mw</u>	<u>480 mw</u>	<u>500 mw</u>
	0	0	X	X	X
	0	0	X	X	X
	0	0	0	X	X
	0	0	0	X	X
	0	0	0	0	X
	0	0	X	0	0
	0	0	0	X	X
	0	0	X	0	X
	0	X	0	0	X
	<u>0</u>	<u>0</u>	<u>X</u>	<u>X</u>	<u>0</u>
Total	10	10	10	10	10
Fired	0	1	5	6	8
Percent	0	10	50	60	80

X = fired
 0 = non-fires

In this sample, ten detonators were subjected to 0.48 watts of power as a starting point, and six out of the ten detonators functioned. We then picked points above and below this level and fired more groups. If any of the points selected produce all fires or all non-fires, then points between these levels should be established. Runs of all fires or all non-fires (such as the 400 mw level) produce very little useful data in a Probit analysis.

Plotting the points obtained from the firing data, as percentage of fire vs. power, gives a sigmoid curve, (S shaped). By using a normalizing transformation equation the percent fires are converted into "probit units" (these points are usually picked from a chart previously prepared rather than by solving the equation). This transformation converts the sigmoid curve into a straight line function. The points are plotted on graph paper with the Y coordinate in probit units and the X coordinate in power units. A provisional probit line is drawn

through the points, by eye. The deviation in the Y direction between the plotted point and the line is inserted into the probit regression equation where, by a succession of approximations, we obtain the final regression line. An example of this is shown in Figure A-2.

A-1.3 Comparison of the Two Techniques

The advantage of the Bruceton analysis is that it gives an accurate mean (50%) firing level and the ability to determine the levels approaching all-fire and no-fire. On the other hand, the probit analysis can be made to give an accurate determination of the end points.

As an example, if the 99 percent point is required accurately, then all of the items could be tested at this point. By doing this, an accurate determination would be made at this level, at the expense of information at other levels.

To obtain the sensitivity of an EED at a specific frequency; i.e., find the 50% point and the two extremes, it usually requires fewer initiators if the Bruceton analysis is used.

There is, however, one situation where probit analysis is required. The soundness of a Bruceton type test depends upon a narrow spread in sensitivity, (σ), in the sample lot. If the sensitivity spread is wide, the probit analysis should be used. It is important that the items be random sampled when this happens, otherwise the data could be biased.

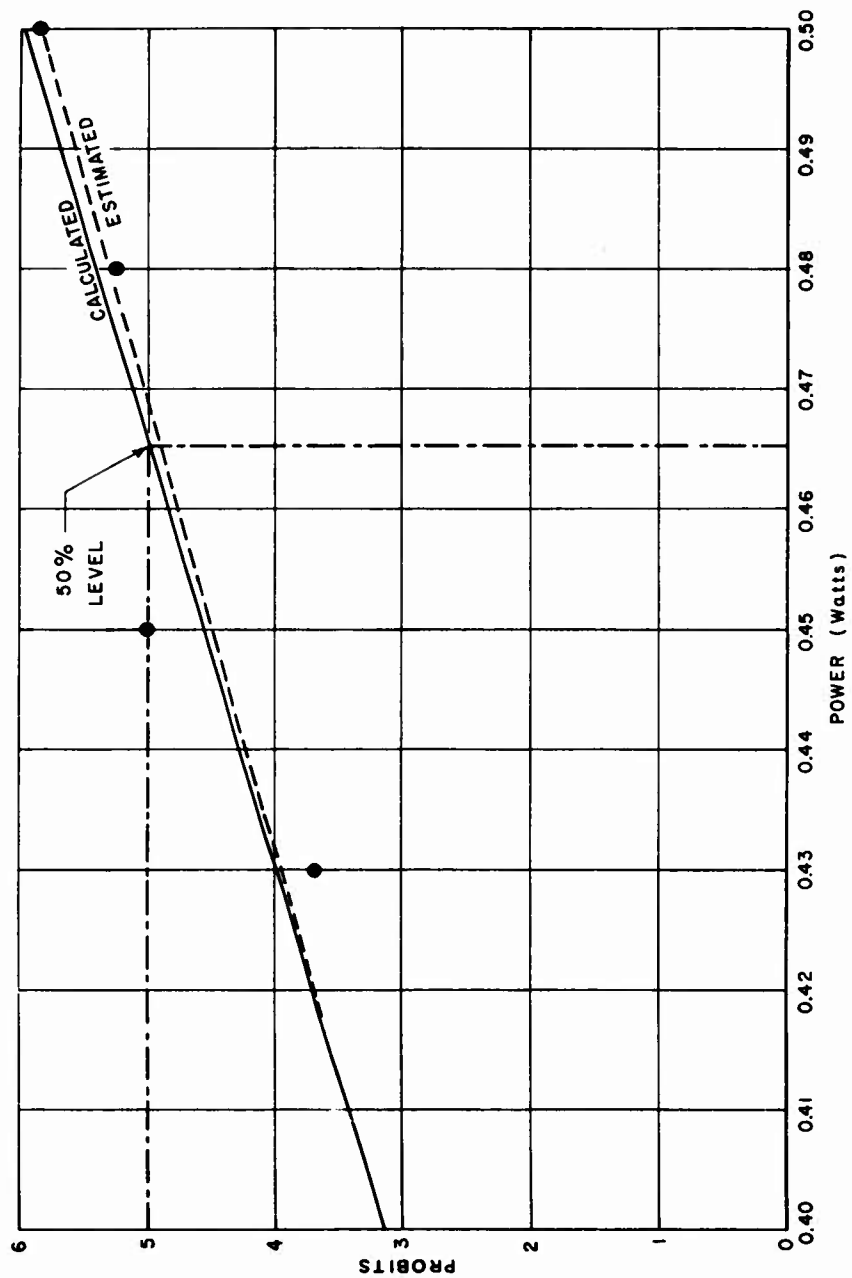

FIG. A-2. FIRING SENSITIVITY USING PROBIT TECHNIQUE

A-2 Initiator Mounting Considerations

When a sample initiator having lead wires rather than a pin connector is to be evaluated it is mounted at the end of the line, the question of proper lead lengths arises. Experience has proven that the leads should be as short as possible. First, let us consider what determines how short we can make the leads. In Figure A-3(a) we have a diagram of a twin lead-wire electric initiator fastened to the end of a coaxial line. It will be noted that when this device, which is essentially a twin lead transmission line, is connected to the end of the coaxial line a section, or loop which is unshielded, can behave as an antenna. As the frequency becomes higher this loop becomes more efficient as an antenna in radiating energy out into space. Loss of energy by radiation is not easily detected and measured by ordinary instrumentation. Its effect is to require greater power for initiation and the presence of stray RF fields in the laboratory is obviously undesirable. To overcome this difficulty, the mounting method shown in Figure A-3(b) is used so that the energy can not radiate into space, and therefore, unless reflected back toward the generator, it must be absorbed by the electro-explosive device.

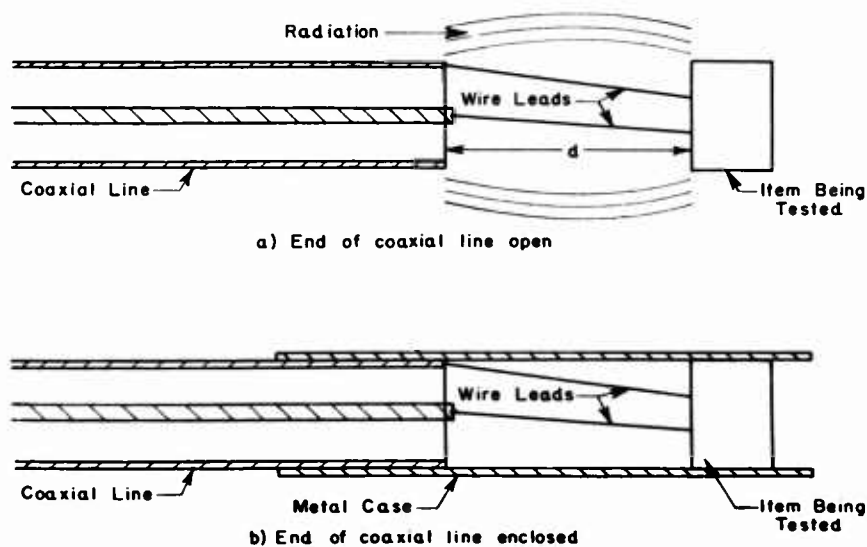
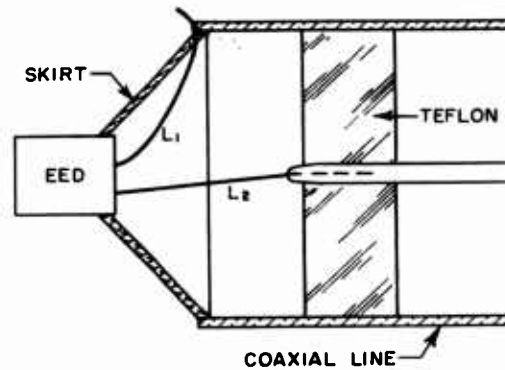

FIG A-3. MOUNTING WIRE LEAD INITIATORS

Figure A-4 shows one lead of an electroexplosive device connected between the outside conductor and a conducting skirt around the EED, and Figure A-5 shows a wire crimped between the case of the EED and the skirt. In practice, this difference represents about $\frac{1}{4}$ -inch of lead length, which is of greater significance than one might suppose.

A twin lead EED was evaluated using both techniques. When the lead was crimped between outer conductor and the skirt, the apparent mean firing level was 120 milliwatts. Crimping the lead between EED case and skirt resulted in a mean firing level of 27 milliwatts: a difference of five to one.

Many of the squibs, bolts, disconnect units, and other EEDs in use today have integral pin type connectors rather than wire leads. When testing a device that includes the connector, a mounting fixture is designed that will make a transition from transmission line to



**FIG A-4. MOUNTING OF EED WITH WIRE LEADS
AS TERMINATION OF COAXIAL LINE
(Long Lead)**

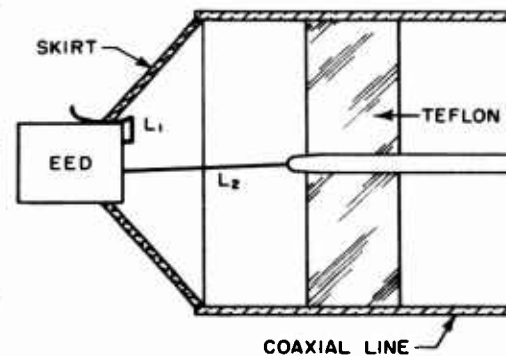

**FIG A-5. MOUNTING OF EED WITH WIRE LEADS
AS TERMINATION OF COAXIAL LINE
(Shortened Lead)**

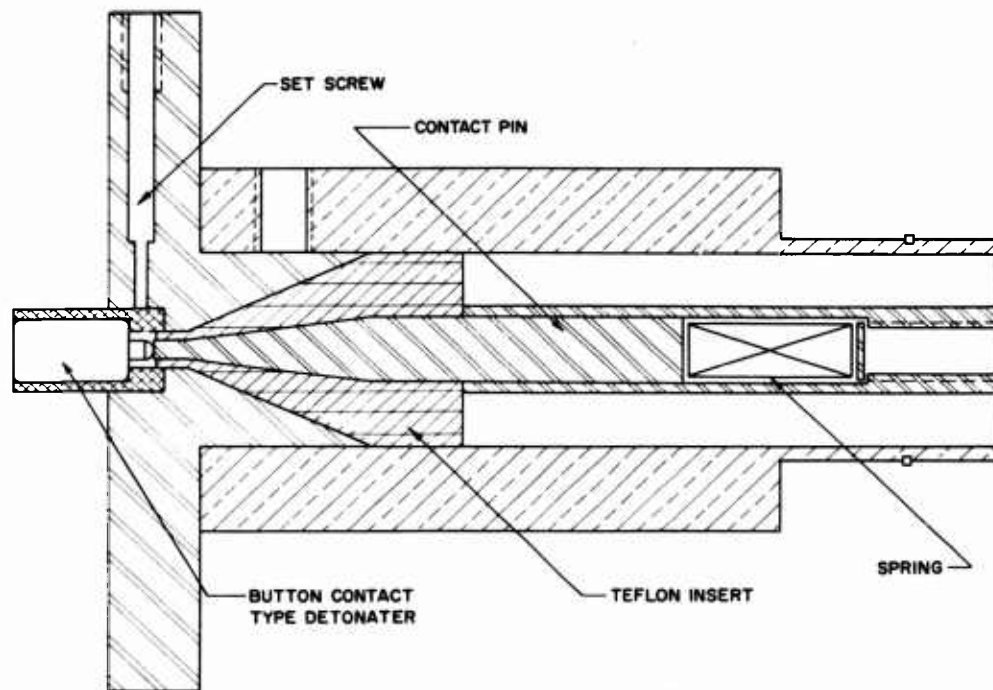

FIG A-6. MOUNTING OF A BUTTON TYPE DETONATOR

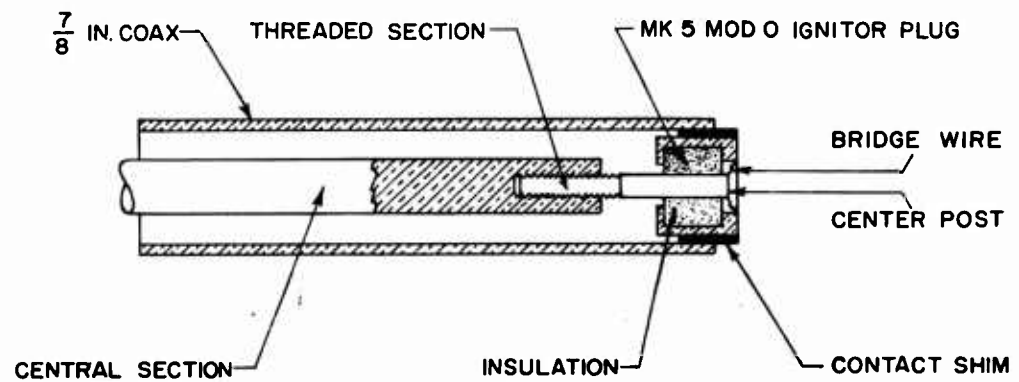

FIG A-7. TEST FIXTURE FOR MARK 5 MOD 0 IGNITION ELEMENT

connector, a better procedure than removing the connector. Figures A-6, 7 and 8 shown some typical mounts that have been used successfully. It is sometimes necessary to make one important change in the connector. In many of the plugs there is a rubber insert which has losses dependent in some manner upon frequency. Since it is intended to evaluate the EED itself, and not the losses in the connector, the rubber insert should be removed and replaced with one made from teflon which is a very poor absorber of RF.



FIG. A-8. RF MOUNT FOR MARK 2 MOD 0 IGNITION ELEMENT

THE FRANKLIN INSTITUTE • *Laboratories for Research and Development*

LM-B1980-2

DISTRIBUTION LIST

Commander
U.S. Naval Weapons Laboratory
Dahlgren, Virginia
Code: WHR 2

Chief, Bureau of Naval Weapons
Department of the Navy
Washington 25, D.C.
Code: C-132

RAAV-3421
RM-15
RMMO-224
RMMO-235
RMMO-32
RMMO-33
RMMO-4
RMMO-43
RMMO-44
RMMP-343
RREN-32
DIS-313 4

Commander
U.S. Naval Ordnance Laboratory
White Oak, Maryland
Code: ED
NO
LV
Technical Library

Officer-in-Charge
U.S. Naval Explosive Ordnance
Disposal Facility
U.S. Naval Propellant Plant
Indian Head, Maryland

Commander
Pacific Missile Range
P.O. Box 8
Point Mugu, California
Code: 3260

Chief, Naval Operations
Department of the Navy
Washington 25, D.C.
Code: OP-411H

Chief, Bureau of Yards and Docks
Department of the Navy
Washington 25, D.C.
Code: D-200

Commanding Officer
U.S. Naval Ordnance Laboratory
Corona, California
Code: 561

Commander
U.S. Naval Ordnance Test Station
China Lake, California
Code: 556
4572

Commanding Officer
U.S. Naval Air Development Center
Johnsville, Pennsylvania
Code: EL94

Commanding Officer
U.S. Naval Underwater Ordnance Station
Newport, Rhode Island

Director
U.S. Naval Research Laboratory
Washington 25, D.C.
Code: 5410

Commandant of the Marine Corps
Washington 25, D.C.
Code: AO4C

Commanding Officer and Director
U.S. Naval Electronics Laboratory
San Diego 52, California
Attn: Library

THE FRANKLIN INSTITUTE • *Laboratories for Research and Development*

LM-B1980-2

DISTRIBUTION LIST (Cont)

Commanding Officer
U.S. Naval Ammunition Depot
Crane, Indiana
Code: 34

Commander Naval Air Force
U.S. Atlantic Fleet
U.S. Naval Air Station
Norfolk 11, Virginia
Code: CNAL-724B

Commanding General
Headquarters, Fleet Marine Force,
Pacific
c/o Fleet Post Office
San Francisco, California
Attn: Force Communications
Electronic Officer

Commander,
Seventh Fleet
c/o Fleet Post Office
San Francisco, California

Commander
Pearl Harbor Naval Shipyard
Navy No. 128, Fleet Post Office
San Francisco, California
Attn: Code 280

Commander
Naval Air Force
U.S. Pacific Fleet
U.S. Naval Air Station
North Island, San Diego, California

Office Chief Signal Officer
Research & Development Division
Washington 25, D.C.
Code: SIGRD-8

Commanding Officer
U.S. Naval Ordnance Plant
Macon, Georgia
Code: PD 270

Commander,
Training Command
U.S. Pacific Fleet
c/o U.S. Fleet Anti-Submarine Warfare School
San Diego 47, California

Commander-in-Chief
U.S. Pacific Fleet
c/o Fleet Post Office
San Francisco, California
Attn: Code 4

Commander
New York Naval Shipyard
Weapons Division,
Naval Base
Brooklyn 1, New York
Attn: Code 290

Commander
Portsmouth Naval Shipyard
Portsmouth, New Hampshire

Department of the Army
Office Chief of Ordnance
Washington 25, D.C.
Code: ORDCU-SA
ORDTB
ORDTW

Commanding Officer
Diamond Ordnance Fuze Laboratories
Washington 25, D.C.
Attn: ORDTL-420, Mr. William Binkley

THE FRANKLIN INSTITUTE • *Laboratories for Research and Development*

LM-B1980-2

DISTRIBUTION LIST (Cont)

Commanding Officer
U.S. Army Nuclear Weapon
Corporation
Fort Belvoir, Virginia

Commanding Officer
Picatinny Arsenal
Dover, New Jersey
Attn: Artillery Ammunition &
Rocket Development
Laboratory - Mr. S.M. Adelman
Attn: Evaluation Unit,
Instrumentation Section,
Building 352 - Mr. A. Grinoch

Commanding Officer
U.S. Army Signal Research &
Development Lab.
Fort Monmouth, New Jersey
Attn: SIGEM/EL-GF

Commander
U.S. Army Rocket & Guided Missile
Agency
Redstone Arsenal, Alabama
Attn: ORDXR-R (Plans)

Commanding Officer
White Sands Missile Range, New
Mexico
U.S.A. SMSA
Code: SIGWS-AJ

Director of Office of Special
Weapons Developments
U.S. Continental Army Command
Fort Bliss, Texas
Attn: Capt. Chester I. Peterson
T S Control Officer

Commander
Air Force Missile Test Center
Patrick Air Force Base, Florida
Code: MTRCF

Director
U.S. Army Engineer Research &
Development Labs.
Fort Belvoir, Virginia
Attn: Chief, Basic Research Group

Commanding General
Headquarters 2DRAADCOM
Oklahoma City, A.F.S.
Oklahoma City, Oklahoma

Commanding Officer
U.S. Army Ordnance
Frankford Arsenal
Philadelphia 37, Pennsylvania

Commanding Officer
Office of Ordnance Research, U.S. Army
Box CM, Duke Station
Durham, North Carolina
Attn: Internal Research Division

Commanding General
White Sands Missile Range
New Mexico
Code: ORDBS-G3

Commanding General
U.S. Army Electronic Proving Ground
Fort Huachuca, Arizona
Attn: Technical Library

Headquarters
Air Research and Development Command
Andrews Air Force Base
Washington 25, D.C.
Code: RDMMS-3

Director Nuclear Safety
Kirtland A.F.B., N.M. Research
Code: AFCNS

THE FRANKLIN INSTITUTE • *Laboratories for Research and Development*

LM-B1980-2

DISTRIBUTION LIST (Cont)

Headquarters
Ogden Air Materiel Area
Hill Air Force Base
Ogden, Utah
Code: OYSS

Commander
Griffiss A.F. Base
RADC, Rome, New York
Attn: RCLS/Philip L. Sandler

Director of Missile
Safety Research
Deputy IG for Safety
Norton A.F.B. California

Commanding General
Strategic Air Command
Offutt Air Force Base, Nebraska
Code: DOSDM

Armed Services Explosives Safety
Broad
Department of Defense
Rm 2075, Gravelly Point,
Bldg. T-7
Washington 25, D.C.

Headquarters
Armed Services Technical Information
Agency (TIPCR)
Arlington Hall Station
Arlington 12, Virginia
VIA: U.S. Naval Weapons Laboratory
Dahlgren, Virginia
Code: WHR

U.S. Atomic Energy Commission
Division of Military Application
Washington 25, D.C.

Commander
Air Force Missile Development Center
Holloman Air Force Base
Alamogordo, New Mexico
Attn: MDBG

Commander
Air Force Special Weapons Center
Kirtland Air Force Base
Albuquerque, New Mexico
Attn: SWVSA

Commanding General
Air Fleet Marine Force, Pacific
MCAS, El Toro
Santa Ana, California

Commander
Headquarters Ground Electronics
Engineering Installation Agency
Griffiss Air Force Base
Rome, New York
Code: ROZMWT

Commander
Hanscom Air Force Base, Massachusetts
Codes: AFCCDD/CCEI-1
Attn: Capt. Long

Commander
Field Command
Defense Atomic Support Agency
Albuquerque, New Mexico
Attn: FCDR3

Defense Research Staff
British Embassy
3100 Massachusetts Ave., N.W.
Washington 8, D.C.
Attn: Mr. G. R. Nice
VIA: U.S. Naval Weapons Laboratory
Dahlgren, Virginia
Code: WHR

THE FRANKLIN INSTITUTE • *Laboratories for Research and Development*

LM-B1980-2

DISTRIBUTION LIST (Cont)

Naval Member Canadian Joint Staff 3450 Massachusetts Ave., N.W. Washington 25, D.C. Attn: Staff Officer (Weapons)	American Machine and Foundry Co. Alexandria Division 1025 North Royal Street Alexandria, Virginia
VIA: U.S. Naval Weapons Laboratory Dahlgren, Virginia Code: WHR	The Bendix Corp. Scintilla Division Sidney, N.Y. Attn: R. M. Purdy
Atlas Chemical Industries, Inc. Reynolds Ordnance Section P.O. Box 271 Tamaqua, Pennsylvania Attn: Mr. R. McGirr	Bermite Powder Company 22116 West Soledad Canyon Road Saugus, California Attn: Mr. L. LoFiego
Chance Vought Corporation P.O. Box 5907 Dallas 22, Texas Attn: R.D. Henry	Aerojet-General Corporation P.O. Box 296 Azusa, California Attn: Myra Z. Grenier, Librarian
Grumman Aircraft Engineering Corp. Weapons Systems Department Bethpage, Long Island, New York Attn: Mr. E. J. Bonan	Jansky and Bailey, Inc. 1339 Wisconsin Avenue, N.W. Washington, D.C. Attn: Mr. F. T. Mitchell, Jr.
Lockheed Aircraft Corporation P.O. Box 504 Sunnyvale, California Attn: Missile Systems Division, Dept. 62-20, Mr. I.B. Gluckman	McCormick-Selph Associates Hollister, California Attn: Technical Library
Attn: Missiles and Space Division, Dept. 81-62, Mr. E.W. Tice	Midwest Research Institute 425 Volker Boulevard Kansas City, Missouri
Attn: Missiles and Space Division, Dept. 81-71, Mr. R.A. Fuhrman	Attn: Security Officer

THE FRANKLIN INSTITUTE • *Laboratories for Research and Development*

LM-B1980-2

DISTRIBUTION LIST (Cont)

RCA Service Company
Systems Engineering Facility
Government Service Department
838 N. Henry Street
Alexandria, Virginia
Attn: C. M. Fisher

University of Denver
Denver Research Institute
Denver 10, Colorado
Attn: Mr. R. B. Feagin

Vitro Laboratories
14000 Georgia Avenue
Silver Spring, Maryland
Attn: Miss C. Jaques, Librarian

North American Aviation Inc.
Communication Services
4300 E. 5th Ave.
Columbus 16, Ohio

Scientific and Technical Info.
Facility
P.O. Box 5700
Bethesda, Maryland
Attn: NASA Representative
(SAK/DL-469)

Sandia Corporation
Division 1262
Albuquerque, New Mexico
VIA: Commander, Field Command
Defense Atomic Support Agency
Albuquerque, New Mexico

Flare Division
Atlantic Research Corporation
19701 W. Goodvale Road
Saugus, California
Attn: Mr. N. E. Eckert, Head,
R&D Group

Welex Electronics Corporation
Solar Building, Suite 201
16th and K Streets, N. W.
Washington 5, D.C.

Scientific and Technical Info. Facility
P.O. Box 5700
Bethesda, Maryland
Attn: NASA Representative (SAK/DL-469)

UNCLASSIFIED

UNCLASSIFIED