

UNCLASSIFIED

AD 431580

DEFENSE DOCUMENTATION CENTER

FOR

SCIENTIFIC AND TECHNICAL INFORMATION

CAMERON STATION, ALEXANDRIA, VIRGINIA



UNCLASSIFIED

NOTICE: When government or other drawings, specifications or other data are used for any purpose other than in connection with a definitely related government procurement operation, the U. S. Government thereby incurs no responsibility, nor any obligation whatsoever; and the fact that the Government may have formulated, furnished, or in any way supplied the said drawings, specifications, or other data is not to be regarded by implication or otherwise as in any manner licensing the holder or any other person or corporation, or conveying any rights or permission to manufacture, use or sell any patented invention that may in any way be related thereto.

64-10

431580

ASD-TDR-63-7-695A

PT-675

FINAL REPORT ON

ENGINEERING AND PRODUCTIZATION OF AN INTEGRATED
FAMILY OF BACKWARD WAVE OSCILLATORS

VOLUME - TWO: APPENDICES

Technical Documentary Report No. ASD-TDR-63-7-695A

October 1963

Electronics Branch Manufacturing Technology Division
Air Force Materials Laboratory
Research and Technology Division
Air Force Systems Command
U. S. Air Force

ASD PROJECT 7-695A

Prepared Under

Contract: AF33(600)-43395

Prepared by

RAYTHEON COMPANY
Microwave and Power Tube Division
Spencer Laboratory
Burlington, Massachusetts

Peter Janis
James Gallagher

VOLUME 2 of 2

CATALOGED BY DDC

AS AD NO.

431580

NOTICES

When Government drawings, specifications, or other data are used for any purpose other than in connection with a definitely related Government procurement operation, the United States Government thereby incurs no responsibility nor any obligation whatsoever; and the fact that the Government may have formulated, furnished, or in any way supplied the said drawings, specifications, or other data, is not to be regarded by implication or otherwise as in any manner licensing the holder or any other person or corporation, or conveying any rights or permission to manufacture, use, or sell any patented invention that may in any way be related thereto.

Qualified requesters may obtain copies of this report from the Armed Services Technical Information Agency, (ASTIA), Arlington Hall Station, Arlington, Virginia.

Copies of AMC Technical Reports should not be returned to the AMC Aeronautical Systems Center unless return is required by security considerations, contractual obligations, or notice on a specific document.

VOLUME II

Table of Contents

Section

- APPENDICES: I -M-BWO Design and Test Specifications
II - Family Process Specifications
III - Distribution List
IV - Catalogue Cards

APPENDIX I

M-BWO DESIGN AND TEST SPECIFICATIONS

SEP 1 1963

THIS SHEET OF TEST LIMITS CONFORMS TO SPECIFICATION MIL-E-1D

Description: M-type, BWO, CW, Electrically Tunable, Wide Band Sole Modulable, Permanent Magnet, Liquid Cooled.

Definitions: The following symbols and corresponding definitions shall apply:

<u>Symbol</u>	<u>Tube Element</u>
b1	Accelerator
b2	Delay Line
g	Grid
so	Sole
Eb2/Fx	Adjust delay line voltage to obtain the indicated frequency Fx.
Eso/Fx	Adjust sole voltage to obtain the indicated frequency Fx.
Eb1/Ib2	Adjust accelerator voltage to obtain indicated delay line current.

All voltages are given with respect to the cathode.

This specification is written in three parts. Tubes tested to this specification may be optimized to one or more parts. Procuring agencies should specify only the portions they need to meet their requirements. Part I defines tests on the basic family at delay line currents (Ib2) of 300 mA. Part II defines test on some of the bands at Ib = 500 mA. Tubes designed for this current can be optimized and tested for both Parts I and II, if required. Part III defines tests on tubes designed for particularly high efficiency at the 300 mA operation.

Frequency

<u>Tube Number</u>	1	2	3	4	5	6	7	8	9
Fa	1000	1300	1800	2500	3500	4800	6500	8500	4360
Fb	1100	1440	1990	2765	3840	5235	7015	9125	4745
Fc	1200	1575	2175	3025	4175	5675	7525	9750	5135
Fd	1300	1715	2365	3290	4515	6115	8040	10375	5525
Fe	1400	1850	2550	3550	4850	6550	8550	11000	5910

Absolute Ratings

<u>Parameter</u>	<u>Units</u>	<u>(Note A)</u>		<u>Tube Number</u>	<u>Notes</u>
		<u>Max.</u>	<u>Min.</u>		
Ef	Volts	6.8	---	All	
Eb2	Volts	5300	2000	All	B
Eb1	Volts	2100	---	All	B, J
Eso	-Volts	3500	900	All	B
Eg	-Volts	1000	---	All	B
Ib2	mA	525	---	1	J, M
		325	---	2-6, 9	J, M
		300	---	7, 8	J, M
tk	Sec.	---	60	All	---
VSWR		4:1	---	All	---

<u>Parameter</u>	<u>Units</u>	<u>Max.</u>	<u>Min.</u>	<u>Tube Number</u>	<u>Notes</u>
Tube Body Temperature	°C	150	---	All	D
Electrical Input Pressurization	psia	100	---	All	I
Coolant Pressure	psia	100	---	All	---
RF Output Pressure	psia	45	---	6,7,8,9	---
<u>Design Ratings</u>					
Ef	Volts	6.6	6.0	All	---
Eb2	Volts	5200	2000	All	B
Eb1	Volts	2100	800	All	B, J
Ib1	mA	+3	0	All	---
Eso	-Volts	3400	900	All	B, O
Iso	mA	+5	-20	All	N
Eg	-Volts	700	100	All	B
Ig	mA	+3	-3	All	---
Ib2	mA	500	---	1	M
		300	---	1 to 9	L, J, M
tk	Sec.	---	60	All	K
VSWR		2.1	---	All	G
Tube Body Temperature	°C	150	---	All	D

Storage, Handling and Installation

Cooling, Liquid: Note C
Magnet Isolation: Note E
Vibration, Shock: Note F

Input Connections:
Weight:

Note H
1, 2, 3 - 28 lbs. max.
4, 5 - 25 lbs. max.
6 to 9 - 17 lbs. max.

Note A: These ratings cannot be used simultaneously and no individual rating should be exceeded. The requirements of MIL-E-1D, paragraph 6.5 apply.

Note B: Delay line, sole and grid voltages must be within the indicated limits before the accelerator voltage can be applied. The accelerator voltage shall always be less than the delay line voltage.

Note C: The tube will be adequately cooled with Dimethyl Polysiloxane silicone fluid, per Mil-S-21568A, (20 centistokes viscosity at 25°C) at a flow rate of one gallon per minute with a maximum inlet oil temperature of 100°C. Other coolants may be used -- the tube manufacturer should be consulted.

Note D: Temperature to be measured at the points indicated on the electron tube outline drawing.

Note E: In shipping, storage, handling and installation of the tube, care must be exercised to prevent demagnetization. Energized magnets similar to the tube magnet shall not be brought closer than twelve (12) inches from the tube magnet except in the case where the two magnets are in a side by side repelling relationship where the spacing may be reduced to six (6) inches. Ferro magnetic material should not be brought closer than six (6) inches, from the tube magnet. Certain exceptions to this may be tolerated, depending upon size, shape

Note E: and location of the material. The tube manufacturer shall be consulted for any (Con't) exceptions.

Note F: Reasonable care must be exercised in the transportation, handling and installation of the tube to avoid imparting stress greater than that required by this specification.

Note G: The tube may require a load isolator at load VSWR values above 1.5 to eliminate power or frequency discontinuities. The tube shall not be damaged when operated into a mismatch load with a VSWR of 4 to 1.

Note H: See tube outline drawing (Note 31).

Note I: At ambient air pressures less than 10 psia, means must be provided to insulate the electrical input connections against voltage breakdown. The tube manufacturer should be consulted for details.

Note J: This limit may be exceeded for applications with maximum duty of 0.25 averaged over a 1 sec. interval. The peak current shall not exceed twice the average current specified. Consult tube manufacturer for details.

Note K: The heater voltage may be applied in the following manner:
Step 1 -- heater voltage of $1.8 \pm 10\%$ volts for 15 seconds minimum.
Step 2 -- $6.3 \pm 5\%$ volts for 45 seconds minimum.

Note L: See Note 30.

Note M: This limit may be exceeded under CW operation by 20% at F_a for short term test requirements. Consult tube manufacturer for details.

Note N: This value may be increased to -30 ma for 500 mA operation in accordance with Part II of this specification.

Note O: The sole voltage will be permitted to be below its specified range to zero volts for a duration of 1 second maximum. This test may be performed at a maximum duty cycle of 10% over a period of 1 minute. Consult the tube manufacturer for details.

<u>Ref.</u>	<u>Test</u>	<u>Conditions</u>	<u>Tube Number</u>	<u>Symbol</u>	<u>Min.</u>	<u>Max.</u>	<u>Units</u>
1.9.2	Dimensions:	Per Outline Drawing Note 31	All				
1.5	Holding Period:	t = 24 hrs. (Min.)	All				
1.9.8	Salt Spray Corrosion:	Omit	All				
---	**Operational Vibration:	Note 1					
---	**Shock:	Acceleration 15g; Duration 11±1 millisecond; 3 mutually perpendicular planes; 5 shocks in each direction in each plane; no voltage; Notes 2, 27, 31	All				
---	**Low Frequency Vibration:	Frequency: 5-55 CPS Range Period: 1 Min. Excursion: .08 inch (Total) Planes: 3 (Notes 31, 27) Test Duration 100 Minutes. No Voltages (Note 2)					
---	**High Frequency Vibration:	Frequency: 55-1500 CPS. Range Period; 20 Min. Acceleration: 5g Planes: 3 (Notes 27, 31) Test Cycles: 12 (each plane) No Voltages (Note 2)					
4.9.13	Electrical Input Pressure Test:	Silicon fluid P = 100 psia	All				No leaks
---	Cooling Jacket Drying:	Note 3	All				
---	Cooling Jacket Pressure Test:	Cooling Outlet closed; Input pressure: 100 psia	All				No leaks

<u>Ref.</u>	<u>Test</u>	<u>Conditions</u>	<u>Tube Number</u>	<u>Symbol</u>	<u>Min.</u>	<u>Max.</u>	<u>Units</u>
4.9.11	RF Output Pressure:		6,7,8,9			No leaks	
---	**Coolant Flow Test:	F=1.0 gpm Notes 4,5	All	ΔP :	8	13	psia
4.10.8	**Heater Current Test:	E _f =6.3 volts t _k =60 sec(min.) Note 7	All	I _f :	1.6	4.0	amps
4.10.14.1	**Accelerator Capacity Test:	Note 8	All	C _{b1} :		25	mmfd
4.10.14.1	**Sole Capacity	Note 8	All	C _{so} :	40	72	mmfd

Part I (Tube Numbers 1-6)

Tube Type Numbers

Band	1	2	3	4	5	6	7	8
Litton	L-3721	L-3722	L-3723	L-3724	L-3725	L-3726	L-3727	L-3728
Raytheon	QKA1250	QKA1251	QKA1252	QKA1253	QKA1254	QKA1255	QKA1256	QKA1257

Oscillation Test Conditions Note 9

---	Heater Warmup:	t _k = 60 Sec Note 7	All
---	Heater Voltage:	6.3 volts Note 26	All
---	Load Standing Wave Ratio:	VSWR=1.1 Max.	All
---	Beam Current:	I _{b2} =300 mA I _{b2} =275 mA Notes 10,30	1,2,3,4,5 6,7,8
---	Sole Voltage:	E _{so2} Notes 10,28 E _{so1} Notes 10,29	
---	Ambient & Coolant Temp.:	Note 28	

Part I (Con't)

<u>Ref.</u>	<u>Test</u>	<u>Conditions</u>	<u>Tube Number</u>	<u>Symbol</u>	<u>Min.</u>	<u>Max.</u>	<u>Units</u>
---	Grid Voltage:	Notes 10, 11					
	<u>Oscillation (1)</u>	Note 9					
	Delay line Voltage:	Note 19	All	E _{b2} :	2300	2600	volts
4.10.7.3.2	Tunable Frequency:	E _{so} /F _a , F _c Note 17	All	E _{so} :	900	3400	volts
---	Sole Voltage Excursion:	e _{so} /F _c -F _a Note 14	All	e _{so} :	---	1800	volts
---	Accelerator Voltage:	E _{b1} /I _{b2} Note 12, 13	All	E _{b1} :	900	1900	volts
---	Accelerator Current:	Note 13	All	I _{b1} :	0	+3	mA
4.16.3.6	Power Output:	E _{b1} /I _{b2} Notes 12, 13	1 2 3 4 5 6 7 8	P _o :	200 200 200 180 180 185 150 150	--- --- --- --- --- --- --- ---	watts watts watts watts watts watts watts watts
4.16.3.6	Grid Current:	Note 13	All	I _g :	-3	+3	mA
---	Sole Current:	Note 13	All	I _{so} :	-20	+5	mA
---	Frequency Continuity:	VSWR=1.5 Notes 6, 15	All	MFB:	---	0	---
---	**Spurious Output Ratio:	Notes 6, 16	1,2,3,4,5 6,7 8	Pr: Pr:	15 20	--- ---	db db
	<u>Oscillation (2)</u>	Note 9					
---	Delay line Voltage:	Note 19	All	E _{b2} :	3000	3300	volts

Part 1 (Cont)

<u>Ref.</u>	<u>Test</u>	<u>Conditions</u>	<u>Tube Number</u>	<u>Symbol</u>	<u>Min.</u>	<u>Max.</u>	<u>Unit</u>
4.10.7.3.2	Tunable Frequency:	Eso/Fb, Fd Note 17	All	Eso:	900	3400	volt
---	Sole Voltage Excursion:	eso/Fd-Fb Note 14	All	eso:	---	1800	volt
---	Accelerator Voltage:	Eb1/Tb2 Notes 12, 13	All	Eb1:	900	1900	volt
---	Accelerator Current:	Note 13	All	Ib1:	0	+3	mA
4.16.3.6	Power Output:	Eb1/Tb2 Notes 12, 13	1 2 3 4 5 6 7 8	Po: Po: Po: Po: Po: Po: Po: Po:	200 200 200 180 180 185 150 150	--- --- --- --- --- --- --- ---	watt watt watt watt watt watt watt watt
---	Grid Current:	Note 13	All	Ig:	-3	+3	mA
---	Sole Current:	Note 13	All	Iso:	-20	+5	mA
---	Frequency Continuity:	VSWR=1.5 Notes 6, 15	All	MFB:	---	0	---
---	**Spurious Output Ratio:	Notes 6, 16	1, 2, 3, 4 5, 6, 7 8	Pr: Pr:	15 20	--- ---	db db
	<u>Oscillation (3)</u>	Note 9					
---	Delay line Voltage:	Note 19	All	Eb2:	3700	4000	volt
4.10.7.3.2	Tunable Frequency:	Eso/Fc, Fe Note 17	All	Eso:	900	3400	volt
---	Sole Voltage Excursion:	eso/Fe-Fc Note 14	All	eso:	---	1800	volt
---	Accelerator Voltage:	Eb1/Tb2 Notes 12, 13	All	Eb1:	900	1900	volt
---	Accelerator Current:	Note 13	All	Ib1:	0	+3	mA

Part I (Con't)

<u>Ref.</u>	<u>Test</u>	<u>Conditions</u>	<u>Tube Number</u>	<u>Symbol</u>	<u>Min.</u>	<u>Max.</u>	<u>Units</u>
1.16.3.6	Power Output:	Eb1/Tb2 Notes 12,13	1	Po:	200	---	watts
			2	Po:	200	---	watts
			3	Po:	200	---	watts
			4	Po:	180	---	watts
			5	Po:	180	---	watts
			6	Po:	165	---	watts
			7	Po:	160	---	watts
			8	Po:	150	---	watts
---	Grid Current:	Note 13	All	Ig:	-3	+3	mA
---	Sole Current:	Note 13	All	Iso:	-20	+5	mA
---	Frequency Continuity:	VSWR=1.5 Notes 6,15	All	MFB:	---	0	---
---	**Spurious Output	Notes 6,16	1,2,3,4,5,6,7 8	Pr: Pr:	15 20	---	db db
<u>Oscillation (4)</u>		Note 9					
4.10.7.3.2	Tunable Frequency:	Eb2/Fb,Fd Eso/Fa,Fb Eso/Fd,Fe	All	Eb2:	2300	4000	volts
				Eso2:	1400	2500	volts
				Eso:	900	Eso2	volts
				Eso:	Eso2	3400	volts
---	Accelerator Voltage:	Eb1/Tb2 Note 13	1,2,3,4,5 6,7,8	Eb1:	900	1900	volts
---	Accelerator Current:	Note 13	All	Ib1:	0	+3	mA
---	Grid Current:	Note 13	All	Ig:	-3	+3	mA
---	Sole Current:	Note 13	All	Iso:	-20	+5	mA
4.16.3.6	Power Output:	Eb1/Tb2 Note 13	1	Po:	200	---	watts
			2	Po:	200	---	watts
			3	Po:	200	---	watts
			4	Po:	180	---	watts
			5	Po:	180	---	watts
			6	Po:	165	---	watts
			7	Po:	150	---	watts
			8	Po:	150	---	watts
---	Frequency Continuity:	VSWR=1.5 Notes 6,15	All	MFB:	---	0	---

Part I (Con't)

<u>Ref.</u>	<u>Test</u>	<u>Conditions</u>	<u>Tube Number</u>	<u>Symbol</u>	<u>Min.</u>	<u>Max.</u>	<u>Units</u>
---	**Spurious Output Ratio:	Notes 6, 16	1, 2, 3, 4, 5 6, 7 8	Pr: Pr:	15 20	---	db db
	**Oscillation (5)	Note 9					
4.10.7.3.2	Tunable Frequency:	Eb2/Fa, Fe	All	Eb2:	2000	5200	volts
---	Sole Voltage:	Eso1 Notes 10, 29	All	Eso1:	1400	2400	volts
---	Accelerator Voltage:	Eb1/Ib2 Note 13	1, 2, 3, 4, 5 6, 7, 8	Eb1:	900	1900	volts
---	Accelerator Current:	Note 13	All	Ib1:	0	+3	mA
---	Grid Current:	Note 13	All	Ig:	-3	+3	mA
---	Sole Current:	Note 13	All	Iso:	-20	+5	mA
4.16.3.6	Power Output:	Eb1/Ib2 Note 13	1 2 3 4 5 6 7 8	Po: Po: Po: Po: Po: Po: Po: Po:	200 200 200 180 180 165 150 150	--- --- --- --- --- --- --- ---	watt watt watt watt watt watt watt watt
---	Frequency Continuity:	VSWR=1.5 Notes 6, 15	All	MFB:	---	0	---
---	Spurious Output Ratio:	Notes 6, 16	1, 2, 3, 4 5, 6, 7 8	Pr: Pr:	15 20	---	db db
	<u>Special Tests</u>	Note 9					
4.16.5	*Pulling:	Eso:Eb2/Fa, Fc, Fe Note 20	All	ΔF:	---	25	Mc
---	*Amplitude Modulation:(1)	ΔPo = ± 25% Eso/Fa	All	ΔEb1:	---	±300	volt

Part I (Con't)

<u>Ref.</u>	<u>Test</u>	<u>Conditions</u>	<u>Tube Number</u>	<u>Symbol</u>	<u>Min.</u>	<u>Max.</u>	<u>Unit</u>
	*Amplitude Modulation:(II)	Note 32	All			Note 32	
---	**Thermal-Frequency Drift:	Notes 18, 21	All	ΔF :	---	1/4% of F_a	Mc
	*Sole Current:	F_d (Osc. 3) Note 33	All	iso:	---	+5	mA
---	**Thermal-Frequency Transient Time:	Note 25	All	T:	---	2	Min.
4.11	<u>Life Test</u> Intermittent	Group D	All	T:	1000	---	Hour
	Life Test:	Note 22		Eb1:	---	2000	volts
	Life Test End:	Note 23	All	Ib1:	---	+4	mA
				Ig:	-4	+4	mA
				Po:	Note 24		watts

Part II (Tube Number 1)

Tube Type Numbers

Band 1
Litton L-3721
Raytheon QKA1250-1

Oscillation Test Conditions Note 9

---	Heater Warmup:	$t_k=60$ Sec Note 7
---	Heater Voltage:	6.3 volts Note 28
---	Load Standing Wave Ratio:	VSWR=1.1 Max.
---	Beam Current:	$I_{b2}=500$ mA Note 10, 30
---	Sole Voltage:	Eso2 Notes 10, 28

Part II (Con't)

<u>Ref.</u>	<u>Test</u>	<u>Conditions</u>	<u>Tube Number</u>	<u>Symbol</u>	<u>Min.</u>	<u>Max.</u>	<u>Units</u>
---	Ambient & Coolant Temp.:	Note 28					
---	Grid Voltage:	Notes 10, 11					
	<u>Oscillation (1)</u>	Note 9					
	Delay Line Voltage:	Note 19		Eb2:	2300	2600	volts
4.10.7.3.2	Tunable Frequency:	Eso/Fa, Fc Note 17		Eso:	900	3400	volts
---	Sole Voltage Excursion:	eso/Fc-Fa Note 14		eso:	---	1800	volts
---	Accelerator Voltage:	Eb1/Ib2 Notes 12, 13		Eb1:	900	2000	volts
---	Accelerator Current:	Note 13		Ib1:	0	+3	mA
4.16.3.6	Power Output:	Eb1/Ib2 Notes 12, 13		Po:	400	---	watts
4.16.3.6	Grid Current:	Note 13		Ig:	-3	+3	mA
---	Sole Current:	Note 13		Iso:	-30	+5	mA
---	Frequency Continuity:	VSWR=1.5 Notes 6, 15		MFB:	---	0	---
---	**Spurious Output Ratio:	Notes 6, 16		Pr:	10	---	db
	<u>Oscillation (2)</u>	Note 9					
---	Delay line Voltage:	Note 19		Eb2:	3000	3300	volts
4.10.7.3.2	Tunable Frequency:	Eso/Fb, Fd Note 17		Eso:	900	3400	volts
---	Sole Voltage Excursion:	eso/Fd-Fb Note 14		eso:	---	1800	volts

Part II (Con't)

<u>Ref.</u>	<u>Test</u>	<u>Conditions</u>	<u>Tube Number</u>	<u>Symbol</u>	<u>Min.</u>	<u>Max.</u>	<u>Units</u>
---	Accelerator Voltage:	Eb1/Tb2 Notes 12,13		Eb1:	900	2000	volts
---	Accelerator Current:	Note 13		Ib1:	0	+3	mA
4.16.3.6	Power Output:	Eb1/Tb2 Notes 12,13		Po:	400	---	watts
---	Grid Current:	Note 13		Ig:	-3	+3	mA
---	Sole Current:	Note 13		Iso:	-30	+5	mA
---	Frequency Continuity:	VSWR=1.5 Notes 6,15		MFB:	---	0	---
	**Spuriout Output Ratio:	Notes 6,16		Pr:	10	---	db
	<u>Oscillation (3)</u>	Note 9					
---	Delay line Voltage:	Note 19		Eb2:	3700	4000	volts
4.16.7.3.2	Tunable Frequency:	Eso/Fc, Fe Note 17		Eso:	900	3400	volts
---	Sole Voltage Excursion:	eso/Fe-Fc Note 14		eso:	---	1800	volts
---	Accelerator Voltage:	Eb1/Tbs Notes 12,13		Eb1:	900	2000	volts
---	Accelerator Current:	Note 13		Ib1:	0	+3	mA
4.16.3.6	Power Output:	Eb1/Tb2 Note 12,13		Po:	400	---	watts
---	Grid Current:	Note 13		Ig:	-3	+3	mA
---	Sole Current:	Note 13		Iso:	-30	+5	mA
---	Frequency Continuity:	VSWR=1.5 Notes 6,15		MFB:	---	0	---

Part II (Con't)

<u>Ref.</u>	<u>Test</u>	<u>Conditions</u>	<u>Tube Number</u>	<u>Symbol</u>	<u>Min.</u>	<u>Max.</u>	<u>Units</u>
---	Accelerator Voltage:	Eb1/Tb2 Notes 12,13		Eb1:	900	2000	volts
---	Accelerator Current:	Note 13		Ib1:	0	+3	mA
4.16.3.6	Power Output:	Eb1/Tb2 Notes 12,13		Po:	400	---	watts
---	Grid Current:	Note 13		Ig:	-3	+3	mA
---	Sole Current:	Note 13		Iso:	-30	+5	mA
---	Frequency Continuity:	VSWR=1.5 Notes 6,15		MFB:	---	0	---
	**Spuriout Output Ratio:	Notes 6,16		Pr:	10	---	db
	<u>Oscillation (3)</u>	Note 9					
---	Delay line Voltage:	Note 19		Eb2:	3700	4000	volts
4.16.7.3.2	Tunable Frequency:	Eso/Fc, Fe Note 17		Eso:	900	3400	volts
---	Sole Voltage Excursion:	eso/Fe-Fc Note 14		eso:	---	1800	volts
---	Accelerator Voltage:	Eb1/Tbs Notes 12,13		Eb1:	900	2000	volts
---	Accelerator Current:	Note 13		Ib1:	0	+3	mA
4.16.3.6	Power Output:	Eb1/Tb2 Note 12,13		Po:	400	---	watts
---	Grid Current:	Note 13		Ig:	-3	+3	mA
---	Sole Current:	Note 13		Iso:	-30	+5	mA
---	Frequency Continuity:	VSWR=1.5 Notes 6,15		MFB:	---	0	---

Part II (Con't)

<u>Ref.</u>	<u>Test</u>	<u>Conditions</u>	<u>Tube Number</u>	<u>Symbol</u>	<u>Min.</u>	<u>Max.</u>	<u>Units</u>
	**Spurious Output Ratio:	Note 16		Pr:	10	---	db
	<u>Oscillation (4)</u>	Note 9					
4. 10. 7. 3. 2	Tunable Frequency:	Eb2/Fb, Fd E _{so} /Fa, Fb E _{so} /Fd, Fe		E _{b2} : E _{so2} : E _{so} :	2300 1400 900 Eso2	4000 2500 Eso2 3400	volts volts volts volts
---	Accelerator Voltage:	Eb1/Ib2 Note 13		E _{b1} :	900	2100	volts
---	Accelerator Current:	Note 13		I _{b1} :	0	+3	mA
---	Grid Current:	Note 13		I _g :	-3	+3	mA
---	Sole Current:	Note 13		I _{so} :	-30	+5	mA
4. 16. 3. 6	Power Output:	Eb1/Ib2		Po:	400	----	watts
	Frequency Continuity:	VSWR=1. 5 Notes 6, 15		MFB:	---	0	---
---	** Spurious Output Ratio:	Note 16		Pr:	10	---	db
	<u>Special Tests</u>	Note 9					
4. 16. 5	*Pulling:	Eso:Eb2/Fa, Fc, Fe Note 20		ΔF:	---	25	Mc
---	*Amplitude Modulation:(I)	ΔPo = ± 25% Eso/Fa		ΔE _{b1} :	---	±300	volt
---	*Amplitude Modulation:(II)	Note 32	All			Note 32	
---	**Thermal-Frequency Drift:	Notes 18, 21		ΔF:	---	1/4 of Fe	Mc
	*Sole Current:	Fd (Osc. 3) Note 33		i _{so} :	---	+ 5	mA
---	**Thermal-Frequency Transient Time:	Note 25		T:	---	2	Min.

Part II (Con't)

<u>Ref.</u>	<u>Test</u>	<u>Conditions</u>	<u>Tube Number</u>	<u>Symbol</u>	<u>Min.</u>	<u>Max.</u>	<u>Units</u>
	<u>Life Test</u>						
	Intermittent	Group D		T:	1000	---	Hours
	Life Test:	Note 22					
	Life Test End:	Note 23		Eb1:	---	2100	volts
				Ib1:	---	+4	mA
				Ig:	-4	+4	mA
				Po:	Note 24		watts

Part III (Tubes Number 4 and 9)

Tube Type Numbers

Band	4	9
Litton	L-3724A	L-3729A
Raytheon	QKA1253-2	QKA1258-2

Oscillation Test Conditions Note 9

---	Heater Warmup:	t _k =60 Sec Note 7	All			
---	Heater Voltage:	6.3 volts Note 26	All			
---	Load Standing Wave Ratio:	VSWR=1.1 Max.	All			
---	Beam Current:	Ib2=300 mA Notes 10,30	All			
---	Sole Voltage:	Eso2 Notes 10,28				
---	Ambient & Coolant Temp.:	Note 28				
---	Grid Voltage:	Notes 10,11				

Oscillation (1) Note 9

	Delay line Voltage:	Note 19	All	Eb2:	2300	2600	volts
4.10.7.3.2	Tunable Frequency:	Eso/Fa, Fc Note 17	All	Eso:	900	3400	volts

Part III (Con't)

<u>Ref.</u>	<u>Test</u>	<u>Conditions</u>	<u>Tube Numbers</u>	<u>Symbol</u>	<u>Min.</u>	<u>Max.</u>	<u>Units</u>
---	Sole Voltage Excursion:	eso/Fc-Fa Note 14	All	eso:	---	1800	volts
---	Accelerator Voltage:	Eb1/Ib2 Notes 12, 13	All	Eb1:	800	1900	volts
---	Accelerator Current:	Note 13	All	Ib1:	0	+3	mA
---	Power Output:	Eb1/Ib2 Notes 12, 13	9 4	Po: Po:	220 235	--- ---	watts watts
4.16.3.6	Grid Current:	Note 13	All	Ig:	-3	+3	mA
---	Sole Current:	Note 13	All	Iso:	-20	+5	mA
---	Frequency Continuity:	VSWR=1.5 Notes 6, 15	All	MFB:	---	0	---
---	**Spurious Output Ratio:	Notes 6, 16	All	Pr:	15	---	db
	<u>Oscillation (2)</u>	Note 9					
---	Delay line Voltage:	Note 19	All	Eb2:	3000	3300	volts
4.10.7.3.2	Tunable Frequency:	Eso/Fb, Fd Note 17	All	Eso:	900	3400	volts
---	Sole Voltage Excursion:	eso/Fd-Fb Note 14	All	eso:	---	1800	volts
---	Accelerator Voltage:	Eb1/Ib2 Notes 12, 13	All	Eb1:	800	1900	volts
---	Accelerator Current:	Note 13	All	Ib1:	0	+3	mA
---	Power Output:	Eb1/Ib2 Notes 12, 13	9 4	Po: Po:	220 235	--- ---	watts watts
---	Grid Current:	Note 13	All	Ig:	-3	+3	mA
---	Sole Current:	Note 13	All	Iso:	-20	+5	mA

Part III (Con't)

<u>Ref.</u>	<u>Test</u>	<u>Conditions</u>	<u>Tube Number</u>	<u>Symbol</u>	<u>Min.</u>	<u>Max.</u>	<u>Units</u>
---	Frequency Continuity:	VSWR=1.5 Notes 6,15	All	MFB:	---	0	---
---	**Spurious Output Ratio:	Notes 6,16	All	Pr:	15	---	db
	<u>Oscillation (3)</u>	Note 9					
---	Delay line Voltage:	Note 19	All	Eb2:	3700	4000	volts
4.10.7.3.2	Tunable Frequency:	Eso/Fc, Fe Note 17	All	Eso:	900	3400	volts
---	Sole Voltage Excursion:	eso/Fe-Fc Note 14	All	eso:	---	1800	volts
---	Accelerator Voltage:	Eb1/Ib2 Notes 12,13	All	Eb1:	800	1900	volts
---	Accelerator Current:	Note 13	All	Ib1:	0	+3	mA
---	Power Output:	Eb1/Ib2 Notes 12, 13	9 4	Po: Po:	220 285	---	watts watts
---	Grid Current:	Note 13		Ig:	-3	+3	mA
---	Sole Current:	Note 13	All	Iso:	-20	+5	mA
---	Frequency Continuity:	VSWR=1.5 Notes 6,15	All	MFB:	---	0	---
---	**Spurious Output Ratio:	Note 6, 16	All	Pr:	15	---	db
	<u>Oscillation (4)</u>	Note 9					
4.10.7.3.2	Tunable Frequency:	Eb2/Fb, Fd Eso/Fa, Fb Eso/Fd, Fe	All	Eb2: Eso2: Eso: Eso:	2300 1400 900 Eso2	4000 2500 Eso2 3400	volts volts volts volts
---	Accelerator Voltage:	Eb1/Ib2 Notes 13, 12	All	Eb1:	800	1900	volts

Part III (Con't)

<u>Ref.</u>	<u>Test</u>	<u>Condition</u>	<u>Tube Number</u>	<u>Symbol</u>	<u>Min.</u>	<u>Max.</u>	<u>Units</u>
---	Accelerator Current:	Note 13	All	Ib1:	0	+3	mA
---	Grid Current:	Note 13	All	Ig:	-3	+3	mA
---	Sole Current:	Note 13	All	Iso:	-20	+5	mA
4.13.3.6	Power Output:	Eb1/Ib2 Notes 13	9 4	Po: Po:	220 235	--- ---	watts watts
---	Frequency Continuity:	VSWR=1.5 Notes 8,15	All	MFB:	---	0	---
---	**Spurious Output Ratio:	Notes 8,16	All	Pr:	15	---	db
	<u>Special Tests</u>	Note 9					
4.16.5	*Pulling:	Eso:Eb2/Fa, Fc, Fe Note 20	All	ΔF:	---	25	Mc
	*Amplitude Modulation:(I)	ΔPo = ± 25% Eso/Fa	All	ΔEb1:	---	±300	volts
	*Amplitude Modulation:(II)	Note 32	All			Note 32	
	**Thermal-Frequency Drift:	Notes 18,21	All	ΔF:	---	1/4 of Fe	Mc
	*Sole Current	Fd (Osc. 3) Note 33	All	Iso:	---	+5	mA
	**Thermal-Frequency Transient Time:	Note 25	All	T:	---	2	Min.
	<u>Life Test</u>						
	Intermittent Life Test:	Group D Note 22	All	T:	1000	---	hour.
	Life Test End:	Note 23		Eb1: Ib1: Ig: Po:	---	2000 +4 -4 Note 24	volts mA mA watt:

- Note 1: The tube shall be vibrated at an acceleration of 2 g or a double amplitude of .08 inches, whichever is limiting, from 5 to 1500 cps. The vibration frequency range shall be traversed from 5 to 1500 to 5 cps in a 20-minute period while the tube is operating CW at F_e . If any tube resonance is detected, the tube shall be vibrated at the resonance frequency for 15 minutes and shall then pass oscillations 1 through 4. If no resonance is detected, the tube shall meet the electrical requirements of this specification. The vibration cycle shall be repeated in each of three mutually perpendicular planes as defined by electron tube outline drawing.
- Note 2: After this test, the tube shall meet the requirements of oscillations 1 through 4.
- Note 3: Prior to shipping the tube, the cooling jacket shall be drained and dehydrated if other than silicone oil is used for test purposes. Protective covers shall be attached to the cooling jacket connections.
- Note 4: The pressure difference shall be measured between the inlet and outlet connectors of the tube and includes the pressure drop of the mating fittings.
- Note 5: The test coolant shall be Dimethyl Polysiloxane silicone fluid per specification MIL-S-21586A (20 centistokes viscosity at 25°C). The inlet coolant temperature to the tube shall be 85° C ± 5°C.
- Note 6: To facilitate the measurement of the parameter for this test, the appropriate voltage may be varied dynamically over the entire or any portion of the band of this oscillation.
- Note 7: The heater voltage may be applied in the following manner:
Step 1 - heater voltage of 1.8 ± 10% volts for 15 seconds minimum.
Step 2 - 6.3 ± 5% volts for 45 seconds minimum.
- Note 8: The capacity shall be measured between the indicated electrode and all other electrodes connected together.
- Note 9: The conditions specified under Oscillation Test Conditions apply to all Oscillation tests and Special Tests except where specifically modified.
- Note 10: The operating value to be indicated on each individual tube.
- Note 11: The grid voltage shall be either -100, -200, -300, -400, -500, -600 or -700 volts. For operation, the grid voltage must be set within ± 50 volts of the value indicated on the tube.

- Note 12: This test shall be performed at a constant accelerator voltage which shall be determined as follows:
- Step 1. Apply sinusoidal modulation to the sole bias (Eso2) to obtain the frequency extremes of this oscillation. The bias Eso2 may be varied so as not to exceed the frequency limits of the oscillation.
 - Step 2. Adjust the accelerator voltage to obtain the average current specified Ib2 (Note 10).
 - Step 3. Remove the sinusoidal modulation and tune the sole over the specified range.
- Note 13: The indicated parameter shall be within the limits specified at all frequencies of this oscillation test.
- Note 14: The peak-to-peak voltage necessary to tune the frequency range noted shall not exceed the value specified.
- Note 15: A frequency skip is defined as a missing frequency band (MFB) in excess of 1.0 Mc/s. The specified frequency range for each test group shall be examined for missing frequency bands. The width of the missing frequency band shall be measured at the worst VSWR phase for that band with an accuracy of ± 1 Mc.
- Note 16: The frequency range of the indicated oscillation shall be examined for spurious power output. Any spurious power shall be below the power of the CW carrier by the power ratio (Pr) specified. The range ± 20 Mcs from the CW carrier is excluded from this test.
- Note 17: The sole voltage may be controlled manually for this test.
- Note 18: The Thermal Frequency Drift specified shall not be exceeded for any combination of anode inlet coolant temperature from -54°C to $+100^{\circ}\text{C}$ and ambient temperature from -54°C to $+85^{\circ}\text{C}$. The frequency difference between the maximum and minimum frequencies measured under the four conditions of this test shall not exceed the value specified. The conditions are as follows:
1. Under the condition of anode inlet coolant temperature and tube ambient temperature of $30^{\circ}\text{C} \pm 10^{\circ}\text{C}$ set the center sole voltage Es01 to the value indicated per Note 10 and adjust Eb2 until the tube oscillation is stabilized at Fe. The tube is stabilized when the frequency difference between the maximum and minimum frequency measured over a period on one hour at intervals of five minutes shall not exceed .05% of Fe.
 2. Maintain Es01 and Eb2 at these values. Adjust the tube ambient temperature to $+85^{\circ}\text{C}$ and the anode inlet coolant temperature to $+100^{\circ}\text{C}$. After the tube frequency has stabilized, measure the frequency and note as Fe1.

Note 18: 3. Repeat Step 2, except adjust the tube ambient temperature to -54°C and the anode inlet coolant temperature to -54°C , and note the stabilized frequency as Fe2.
(Con't)

4. Repeat Step 2, except adjust the tube ambient temperature to -54°C and the anode inlet coolant temperature to $+100^{\circ}\text{C}$, and note the stabilized frequency as Fe3.

Note 19: The delay line voltage shall be set so that the mid-frequency of oscillations 1, 2, or 3 (Fb, Fc, or Fd, respectively) is obtained with the same voltage E_{so2} . The conditions of test shall be the same as those listed under Note 28.

Note 20: The load VSWR may be adjusted to 1.5:1 at each test frequency. The pulling figure test shall be made by continuously moving the pulling stub through all phases sufficiently fast to prevent thermal effects. This test shall be performed at Osc. 1, 2, and 3.

Note 21: The tube must be capable of voltage correction of thermal drift, and meet all test conditions of this specification, by means of a change in sole voltage above or below the value E_{so2} (Note 10) as required.

Note 22: Life test shall be conducted only at highest applicable beam current. During life testing, the tube shall be operated for equal amounts of time for Oscillation 1 and Oscillation 3. Operation of the tube shall be alternated between Oscillation 1 and Oscillation 3 at least once every 48 hours. The load VSWR shall be 1.5 and shall be cycled through all phases continuously at a rate of 4 cycles per hour.

(a) Heater preheat	60 seconds maximum
(b) Oscillation	30 minutes maximum
(c) No voltage	5 minutes minimum

Time assignable to life shall be the cumulative oscillation time. All voltages except the heater voltage will be applied to the tube simultaneously (Note B). The heater voltage preheat limitation shall be observed (Note L).

Note 23: End of Life shall be determined by failure to pass any of the oscillation tests as modified by the end of life limits specified.

Note 24: The power output end of life limit shall be 80% of the minimum for each tube type at the beginning of life.

Note 25: The time allowed for the tube to reach a stabilized frequency after full beam current has been established shall not exceed the maximum specified. The tube is stabilized when the frequency difference between the maximum and minimum frequency measured over a period of one hour at intervals of five minutes shall not exceed .05% of Fe. The conditions of test shall be as stated in Note 28.

- Note 26: A heater voltage of 6.3 volts can be used for production test. The tubes must, however, be capable of passing all Oscillation Tests during Design or Qualification Approval with a heater voltage anywhere in the range from 6.0 to 6.6 volts RMS.
- Note 27: The planes shall be mutually perpendicular and as defined on the electron tube outline drawings.
- Note 28: The fixed sole voltage E_{SO2} is defined as the sole voltage recommended by the tube manufacturer for optimum tube operation under conditions of Oscillations 1, 2 and 3 CW of this specification. The conditions of test for determining E_{SO2} shall be as follows:
1. Anode Cooling. Silicone fluid (20 centistokes viscosity at 25°) at a flow rate of 1 gal. \pm 10% per minute and at a temperature at the anode inlet of 30° \pm 10°C.
 2. The external tube ambient temperature shall be 30° \pm 10°C.
- Note 29: The fixed sole voltage E_{SO1} is defined as the sole voltage recommended by the tube manufacturer for optimum tube operation under the conditions of this oscillation test. The conditions of test for determining E_{SO1} shall be the same as specified in Note 28.
- Note 30: The value of delay line current is the normal value. The delay line current indicated on the metal-cal may vary \pm 25 ma from the normal value.
- Note 31: The following outline drawings form a part of this specification:
- | <u>Tube Number</u> | <u>Drawing Number</u> |
|--------------------|-----------------------|
| 1,2,3,4, and 5 | B1-5 |
| 6,7,8, and 9 | B6-9 |
- Note 32: Adjust the tube for Osc.3(FC). Reduce E_{b1} from its normal operating level by 200 volts. The tube must remain in oscillation at this lower voltage level. For qualification, this test will be performed at all test frequencies of Osc. 1, 2, 3, and 4.
- Note 33: Reduce the sole voltage to zero volts. (See Note O.) The sole current shall never exceed the maximum positive value specified.

AIR FORCE DRAWING B 1-5

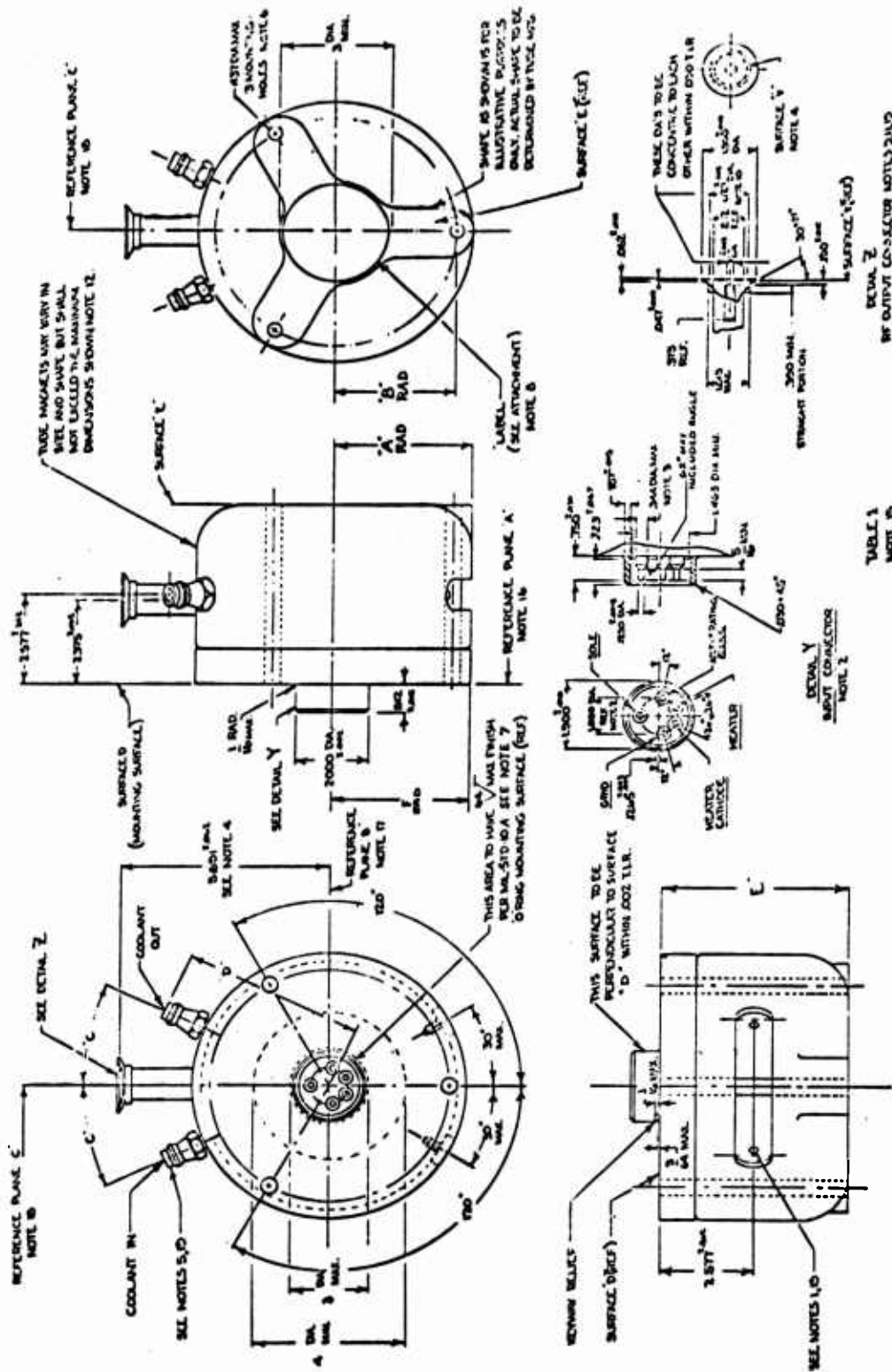
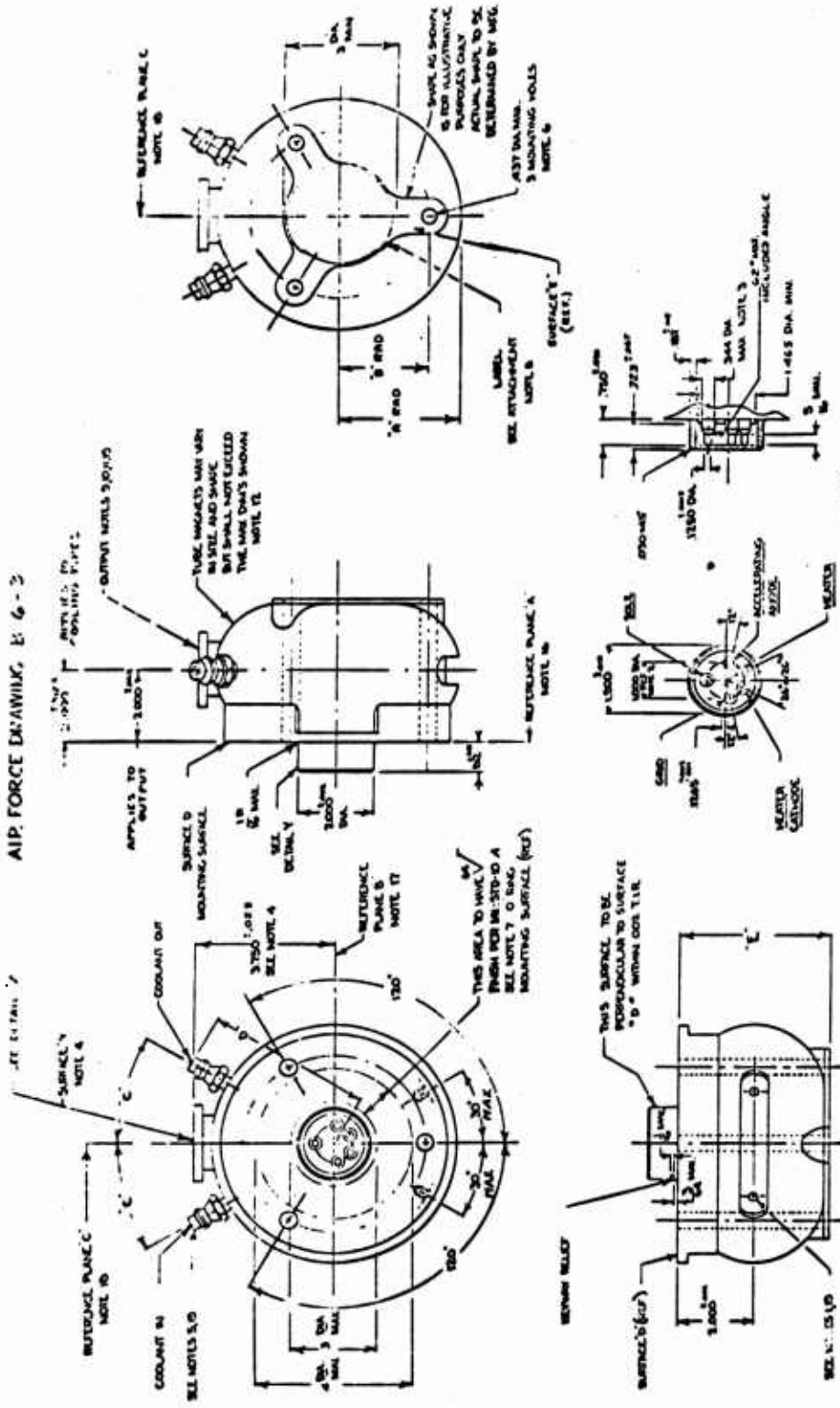

TABLE 1
NOTE 10

PART NO.	BAND NO.	COCK LETTER	A _{MAX}	B _{MAX}	C	D _{MAX}	E _{MAX}	F _{MAX}	F _{MIN}	F _{MIN} COLOR	F _{MIN} DIA
	1	A	3.812	3.120	25.713	4.233	5.100	3.750	3.100	ALUMINUM	3.750
	2	A	3.812	3.350	25.713	4.233	5.100	3.750	3.100	ALUMINUM	3.750
	3	A	3.812	3.350	25.713	4.233	5.100	3.750	3.100	ALUMINUM	3.750
	4	A	3.812	3.350	25.713	4.233	5.100	3.750	3.100	ALUMINUM	3.750
	5	B	3.812	3.350	25.713	4.233	5.100	3.750	3.100	ALUMINUM	3.750

NOTE:
SEE ATTACHED FOR NOTES.

AIR FORCE DRAWING: E 6-3



NOTE 1: SEE ATTACHMENT FOR NOTES.

NOTE 2: SEE ATTACHMENT FOR NOTES.

TABLE 1
NOTE 13

PART NO.	COORD.	A	B	C	D	E	F	G	H	I	J	K	L	M	N	O	P	Q	R	S	T	U	V	W	X	Y	Z	
1	A	3.312	2.275	2.275	4.432	4.432	4.432	4.432	4.432	4.432	4.432	4.432	4.432	4.432	4.432	4.432	4.432	4.432	4.432	4.432	4.432	4.432	4.432	4.432	4.432	4.432	4.432	4.432
2	A	3.312	2.275	2.275	4.432	4.432	4.432	4.432	4.432	4.432	4.432	4.432	4.432	4.432	4.432	4.432	4.432	4.432	4.432	4.432	4.432	4.432	4.432	4.432	4.432	4.432	4.432	4.432

DETAIL 2

MEWO Drawing Notes

- Note 1: Two #6-32 NC tapped holes whose minor diameter shall not exceed .116" for measuring cylinder temperature shall be provided. Location to be determined by the tube manufacturer except for dimensions given. A test cylinder of 0.625" diameter, engaging either one of the two tapped holes for the centrally located 1/4" max. long, number 6-32 NC-2A threaded stud, shall freely clear the magnet.
- Note 2: Electrical input pins are located as shown within 0.015 inches of true geometric location.
- Note 3: Material covering pins shall be of an electrical insulating type compatible with the following fluid, Dimethyl Polysiloxane silicone fluid per MIL-S-21568A (20 centistokes viscosity at 25°C). The above material shall be compatible with this fluid at temperatures from -54°C to +120°C.
- Note 4: The 3.750 or 5.691 dimension includes lateral and angular deviation of surface "Y". Surface "Y" shall be parallel to reference plane "B" within ± 0.015 measured at the periphery.
- Note 5: Male connector to mate with female disconnect coupler, Aeroquip Corp., Jackson, Mich. Part Number 23129 or equivalent.
- Note 6: The 0.437 diameter mounting holes provide clearance for 5/16 diameter non-magnetic bolts which are located as shown, within 0.015 of true geometric location. This applies to both surfaces "D" and "E".
- Note 7: Surface "D" must provide a hermetic seal, and must have a maximum surface finish as specified. Surface is to be flat within 0.0005/inch diameter T.I.R.
- Note 8: Label
- A. Characters to be alternate Gothic 3.
 - B. All character sizes not designated are to be 12 point.
 - C. Material: 0.003 anodized aluminum nameplate per specification MIL-N-25076, type 11. Pressure sensitive adhesive must be compatible with coolant oils specified in Note 3.
- Note 9: For tubes 1 through 5 dimensions 0.812 and 0.375 on rf output connector mate with and are in accordance with RG-44/U transmission line.
- For tubes 6 through 8 the waveguide output mates with AF drawing 57B4486 Revision A.
- For tube 9 the waveguide output mates with AF drawing 62B3117.

- Note 10: For tubes 1 through 5 the axis of the 1.127 dia. to be within ± 0.030 at the intersection of surface "Y" and reference plane "C". For tubes 6 through 8 in the plane of the major axis, the waveguide opening shall be parallel to reference plane "A" within $0^\circ - 20$ maximum. As an alternate, a plane passing through hole "X" of tube flange shall be parallel to ref plane "A" within 012 .
- Note 11: Care must be exercised in handling and processing the tube. The tube should not be lifted by the output connector, nor should unnecessary stresses be imparted to this member. Jarring should be avoided.
- Note 12: In shipping, storage, handling, and installation of the tube, care must be exercised to prevent demagnetization. Energized magnets similar to the tube magnets, shall not be brought closer than 12" from the tube magnet, except in the case where the two magnets are in a side by side repelling relationship where the spacing may be reduced to 6". Ferro-magnetic materials should not be brought closer than 6" from the tube magnet. Certain exceptions to this may be tolerated, depending on size, shape and location of the material. The tube manufacturer shall be consulted for approval of any exceptions.
- Note 13: All rf band numbers to be Mosen black Gothic 612J-24PT.
- Note 14: Meeting point of two colors shall not have a separation line.
- Note 15: Code letters A or B following Air Force part number signify maximum tube diameter as designated in Table 1. Numeral signifies band.
- Note 16: Reference plane "A" is defined as the plane which lies on the mounting plate surface as shown.
- Note 17: Reference plane "B" is defined as the plane perpendicular to plane "A" and passes through the axis of the 2.000" diameter of input connector collar and center-line of the keyway.
- Note 18: Reference plane "C" is defined as the plane perpendicular to planes "A" and "B" and passes through the axis of the 2.000" diameter of input connector collar.
- Note 19: A means of grounding shall be provided for, at one of the following locations tube body, coolant connector, or rf output connector.

A626.597

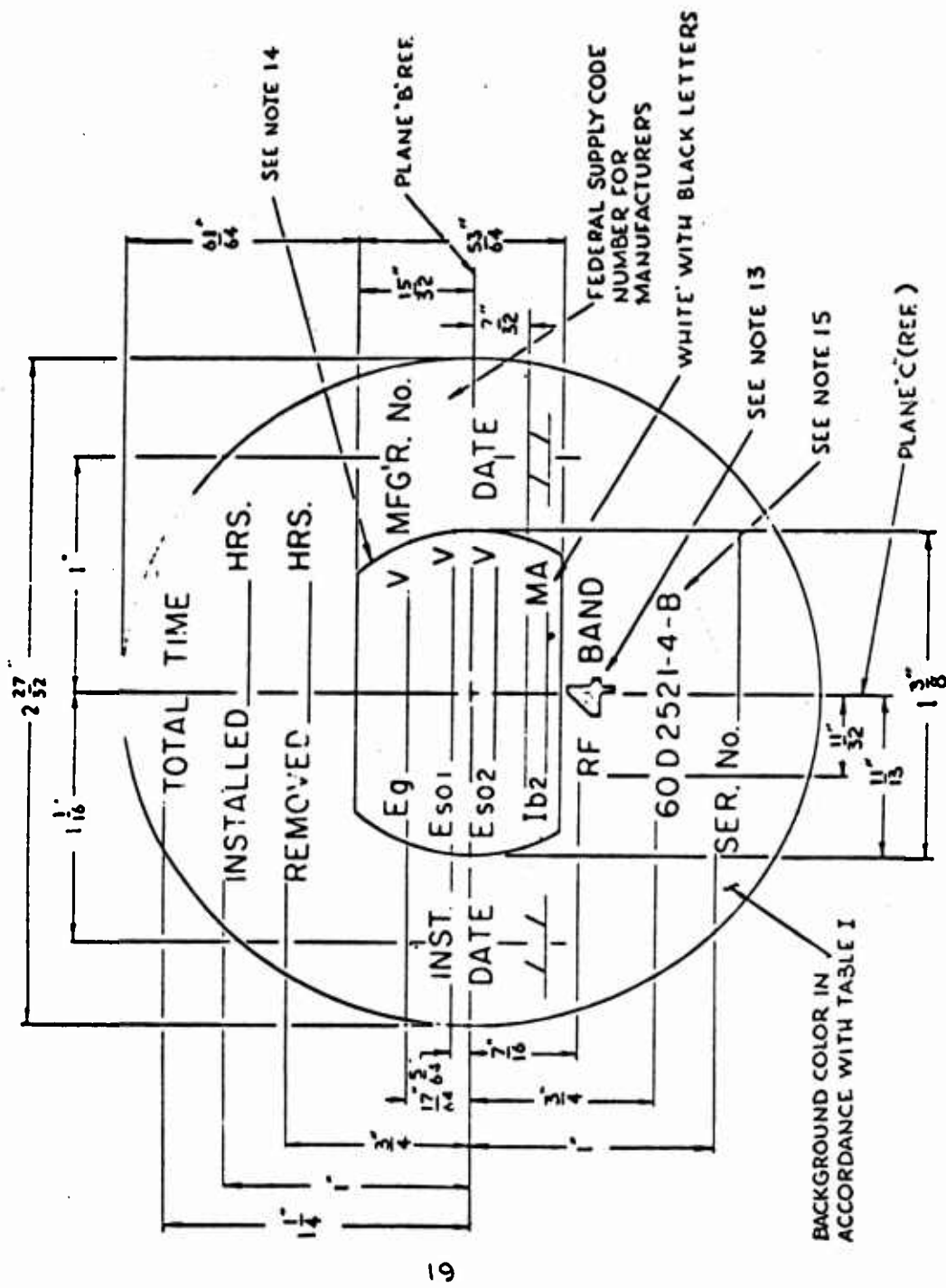

APPENDIX II

FAMILY PROCESS SPECIFICATIONS

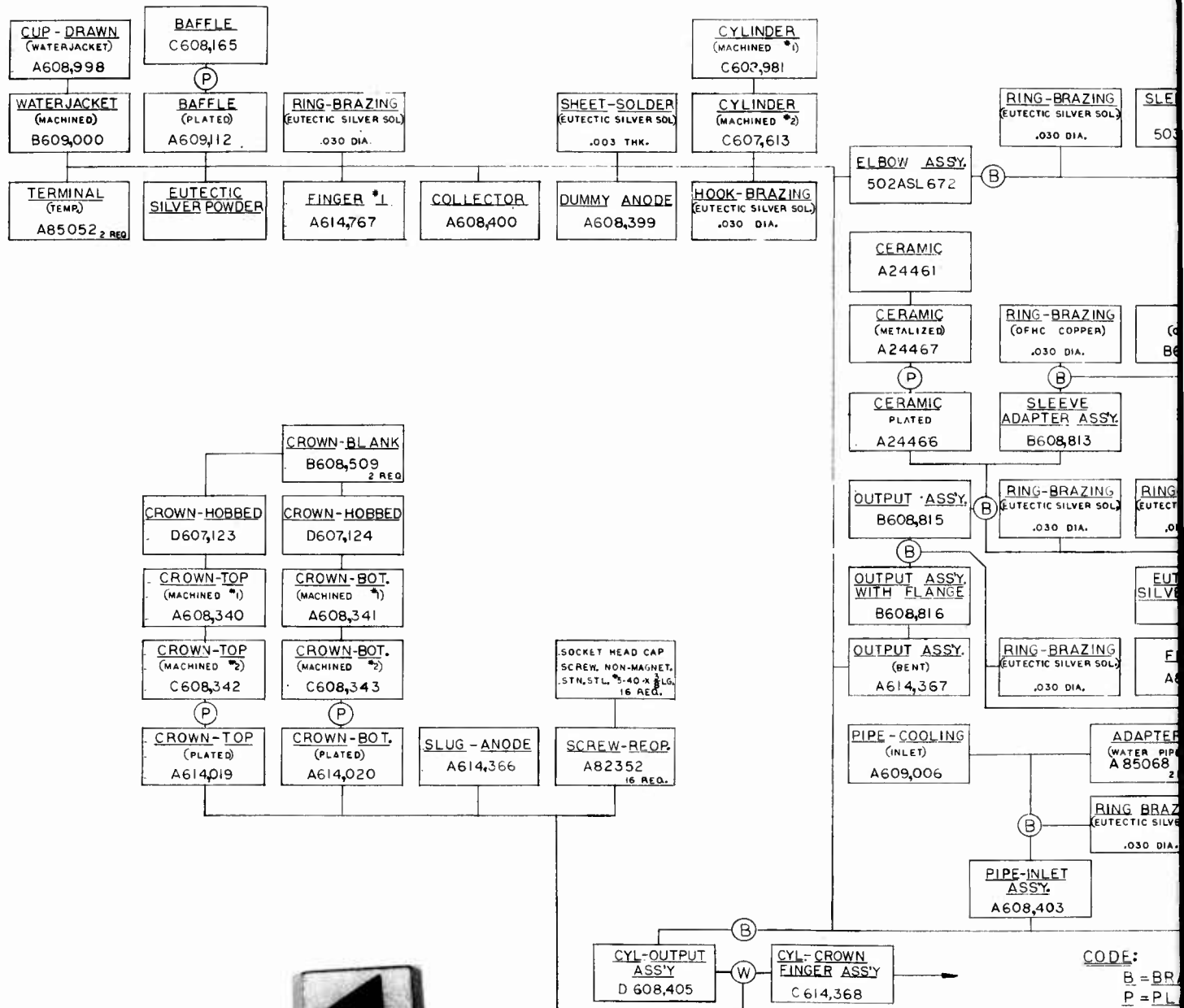

FLOW CHART
CYLINDER CROWN FINGER ASS'Y

QKA 852

CODE:
B = BR
P = PL

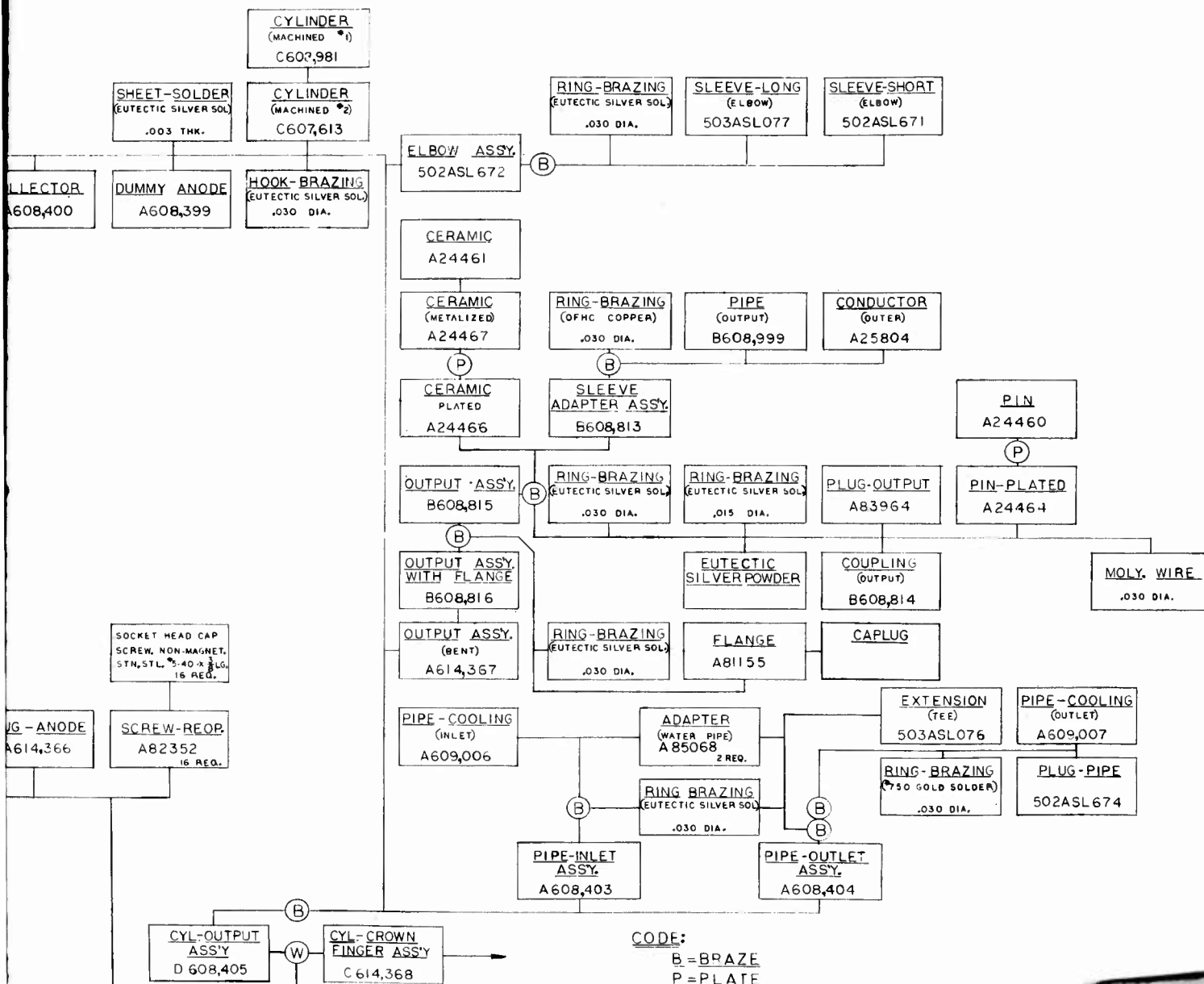

FLOW CHART

CYLINDER CROWN FINGER ASSY

QKA 852

CODE:
B = BRAZE
P = PLATE



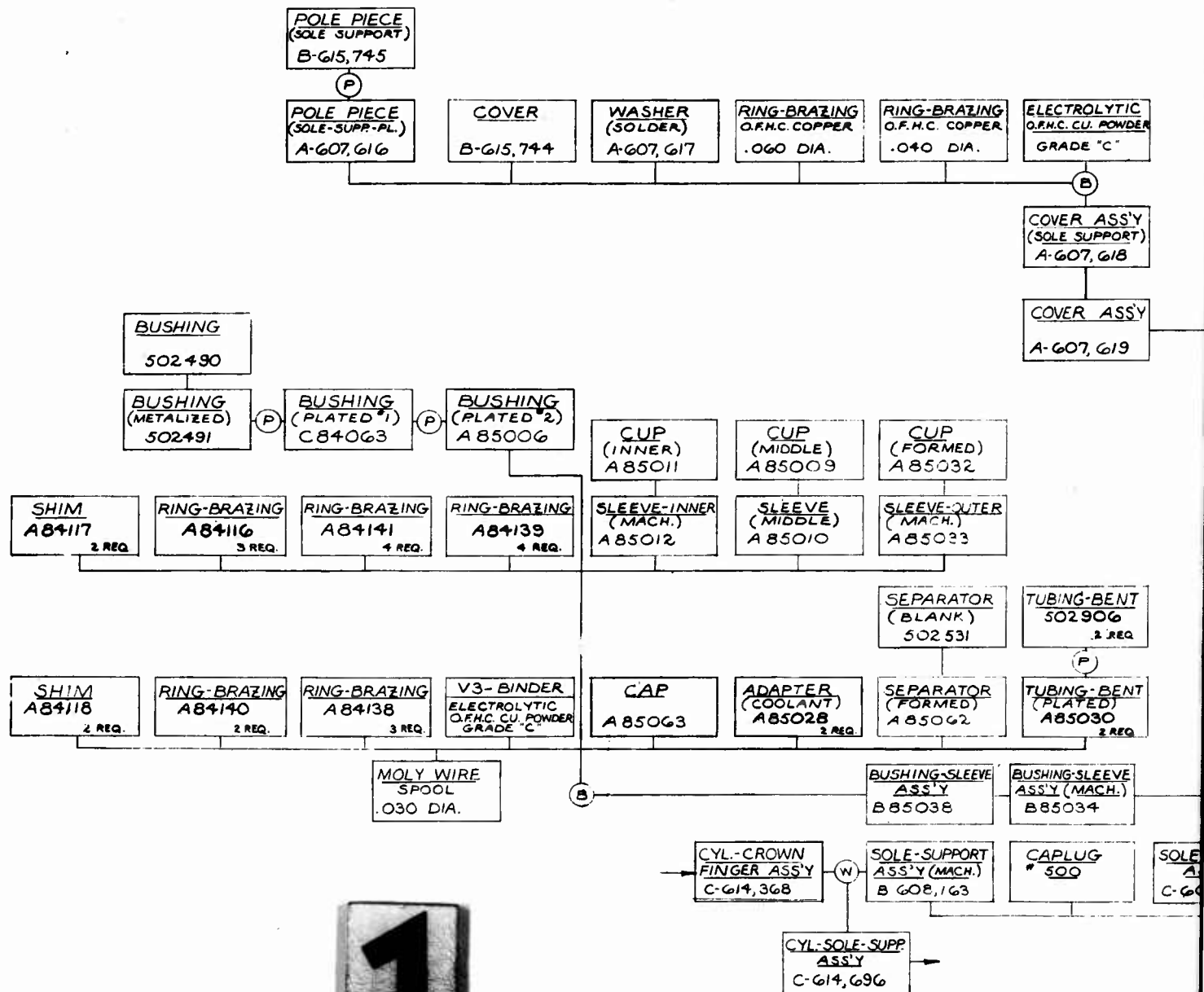

FLOW CHART
CYL.-SOLE SUPPORT ASS'Y
QK852

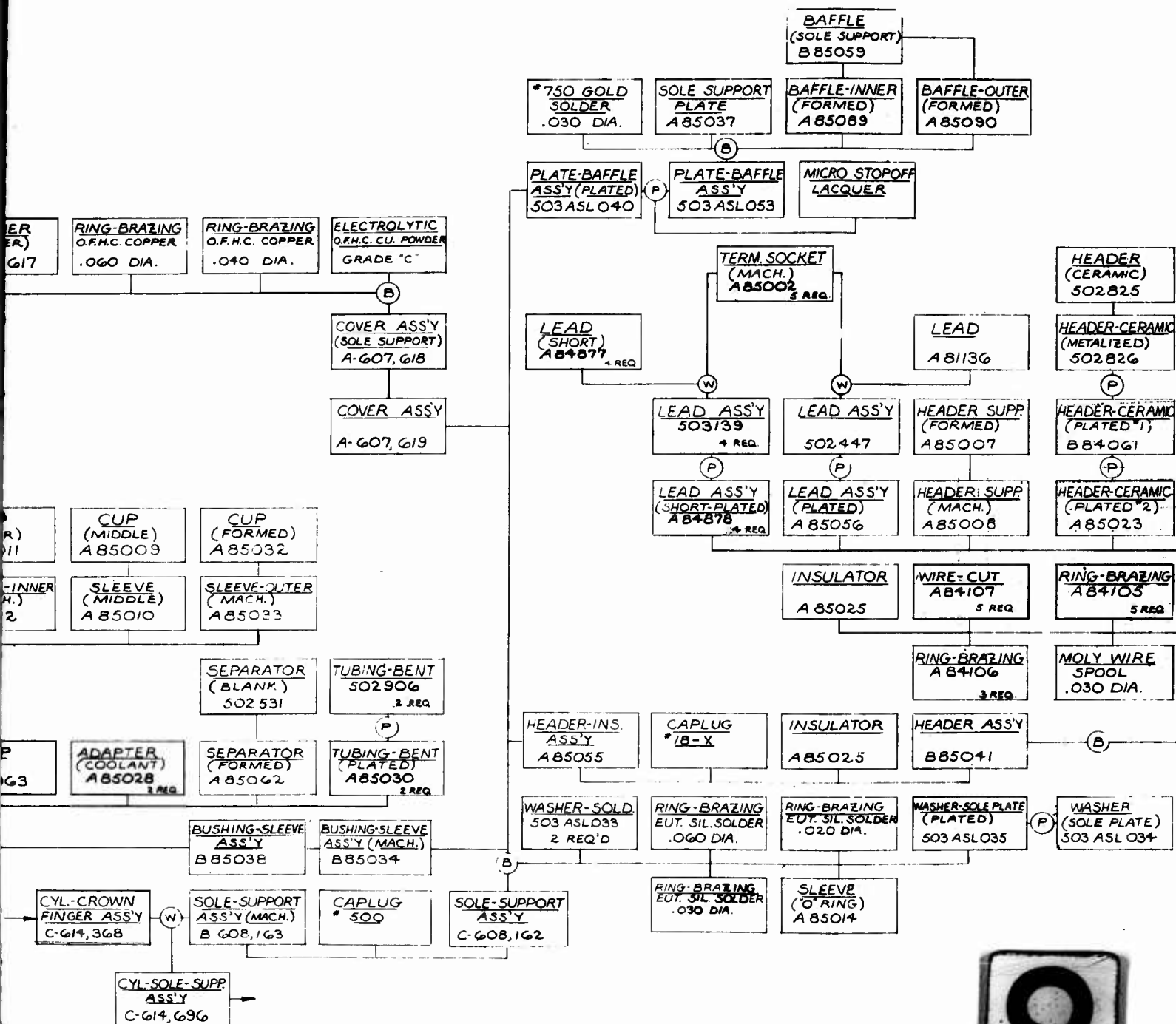

FLOW CHART
CYL-SOLE SUPPORT ASS'Y
QK852



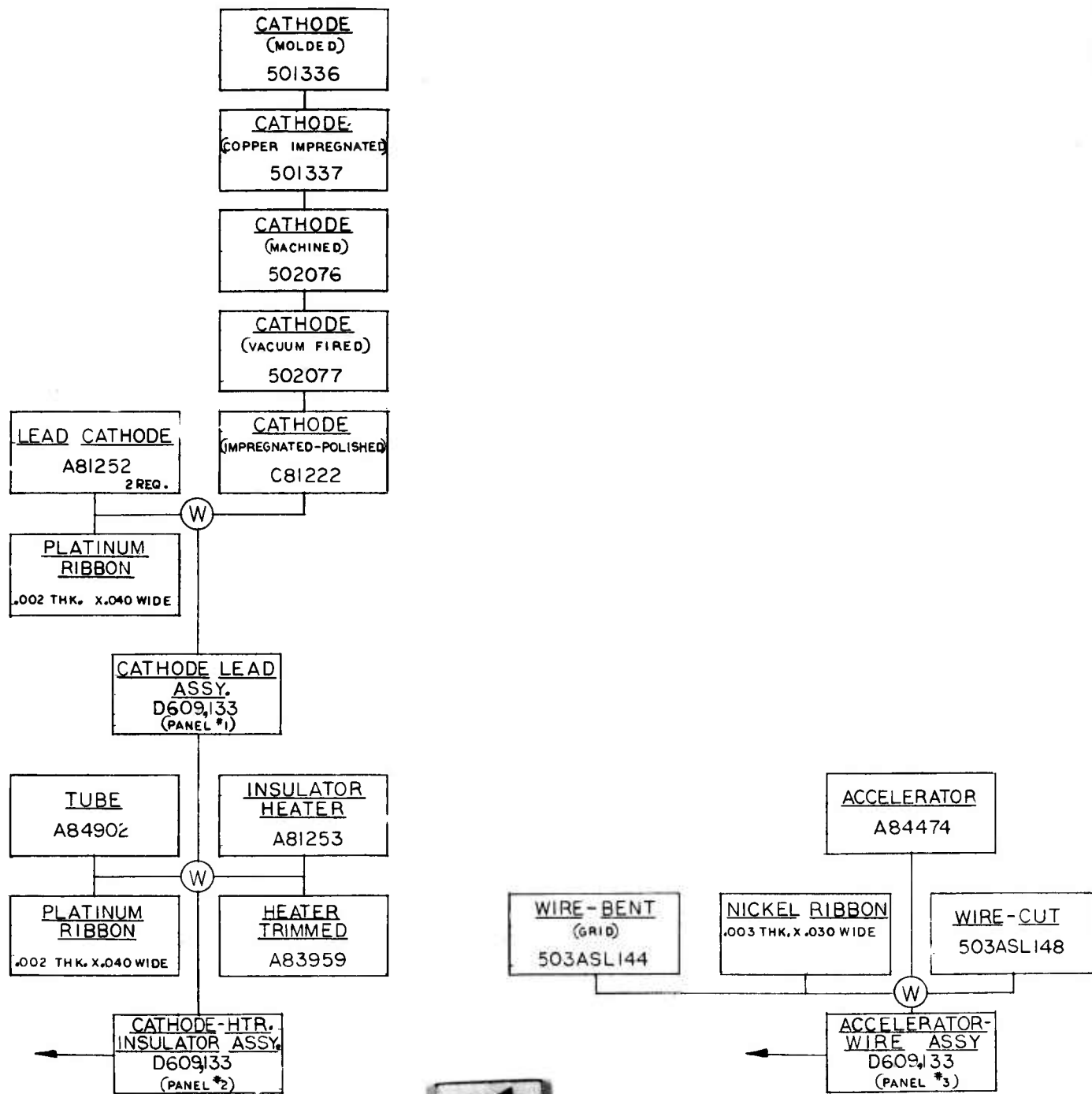

FLOW CHART
GUN ASSEMBLY
QKA 852

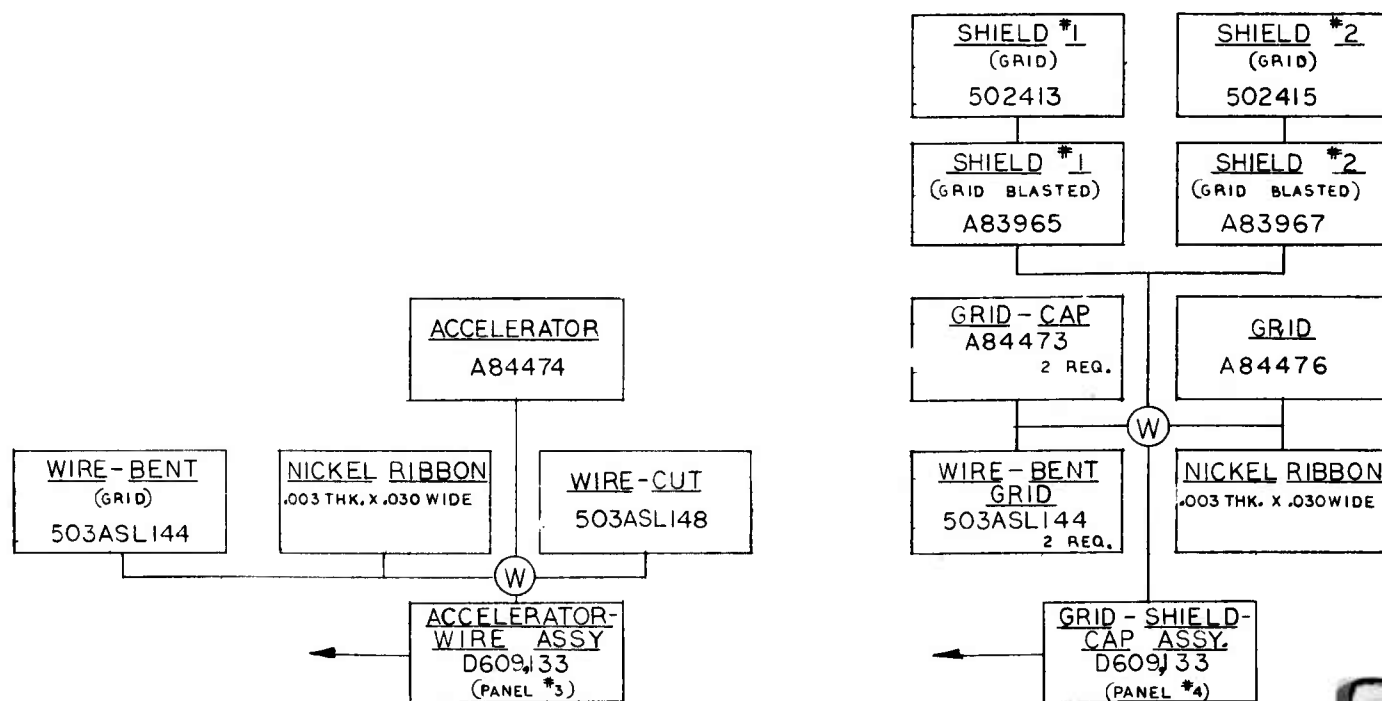

FLOW CHART
GUN ASSEMBLY
QKA 852



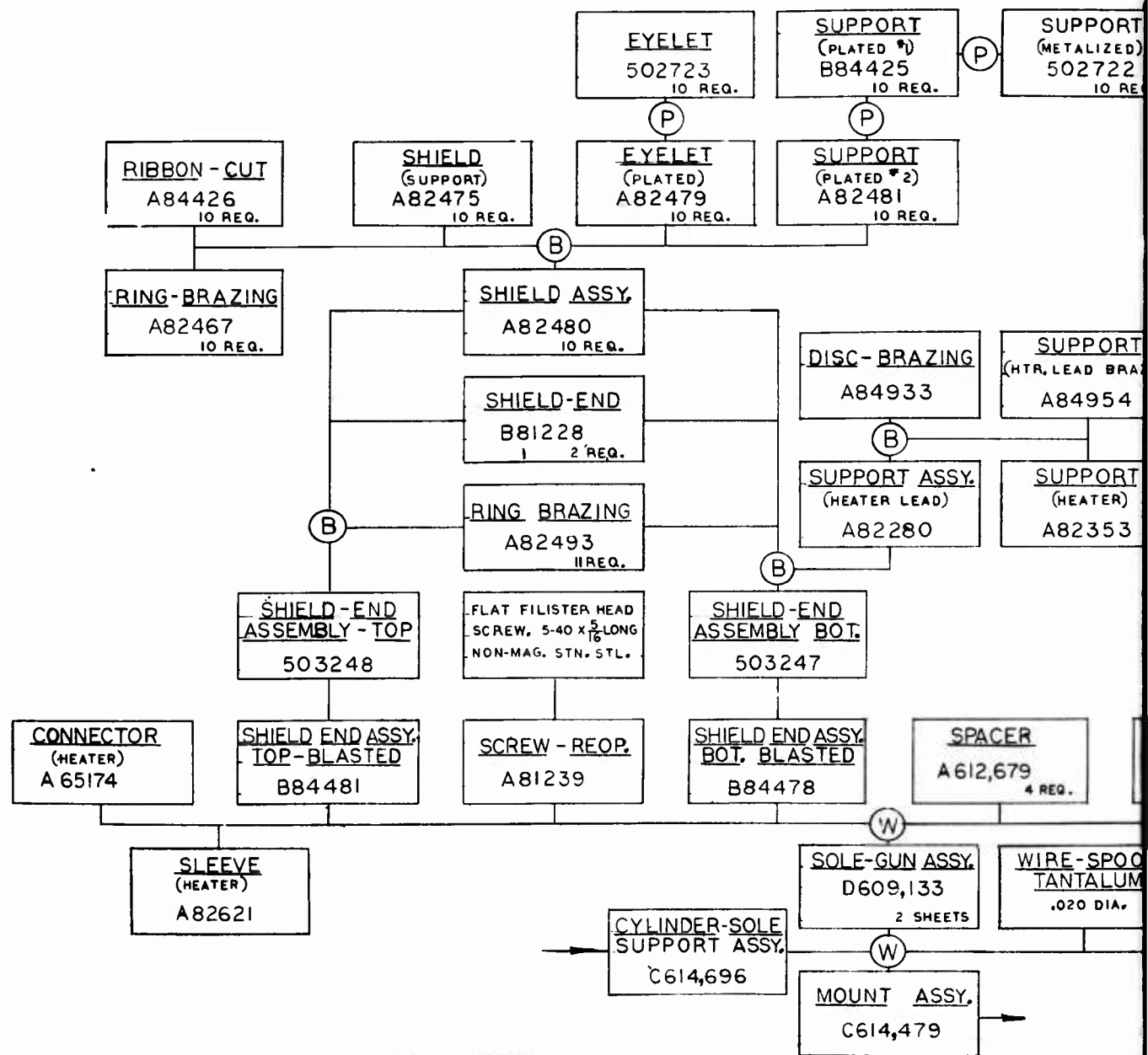

FLOW CHART
MOUNT ASSEMBLY
QKA 852

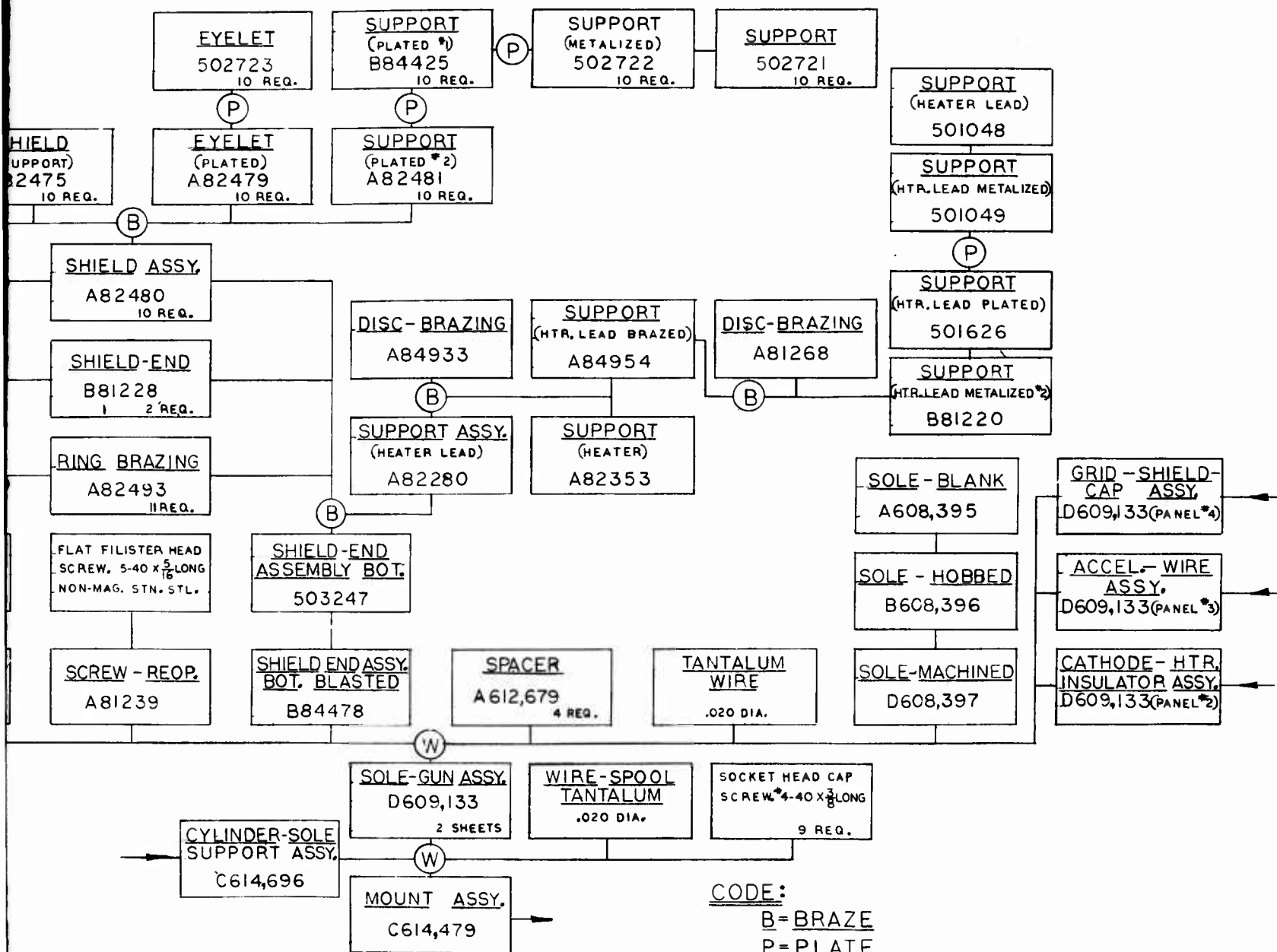

FLOW CHART
MOUNT ASSEMBLY
QKA 852

CODE:
B = BRAZE
P = PLATE
W = WELD



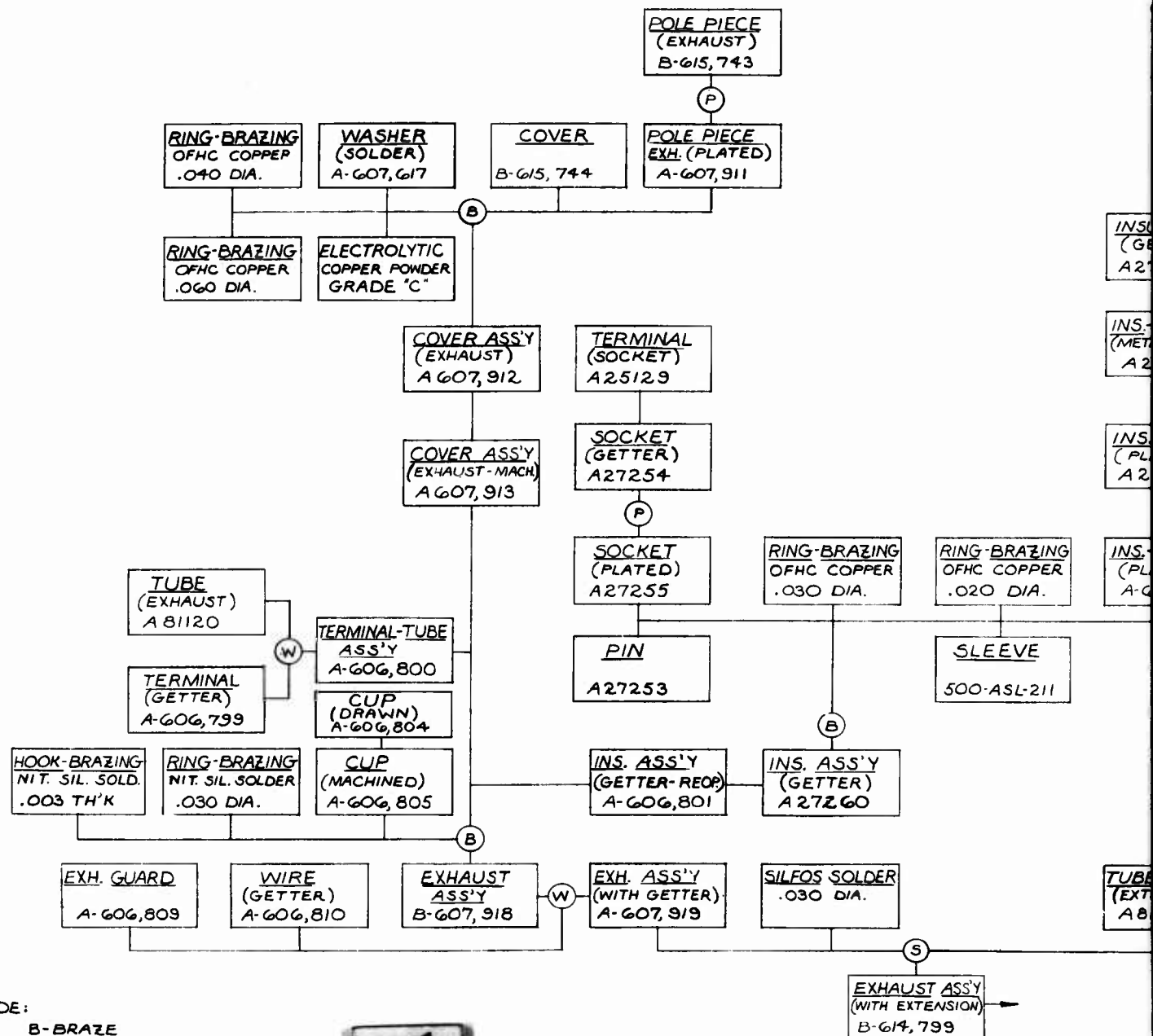

CODE:

B- BRAZE
W- WELD
P- PLATED
G- GLASSED
S- SOLDER



QKAB52 FLOW CHART (EXHAUST ASS'Y)

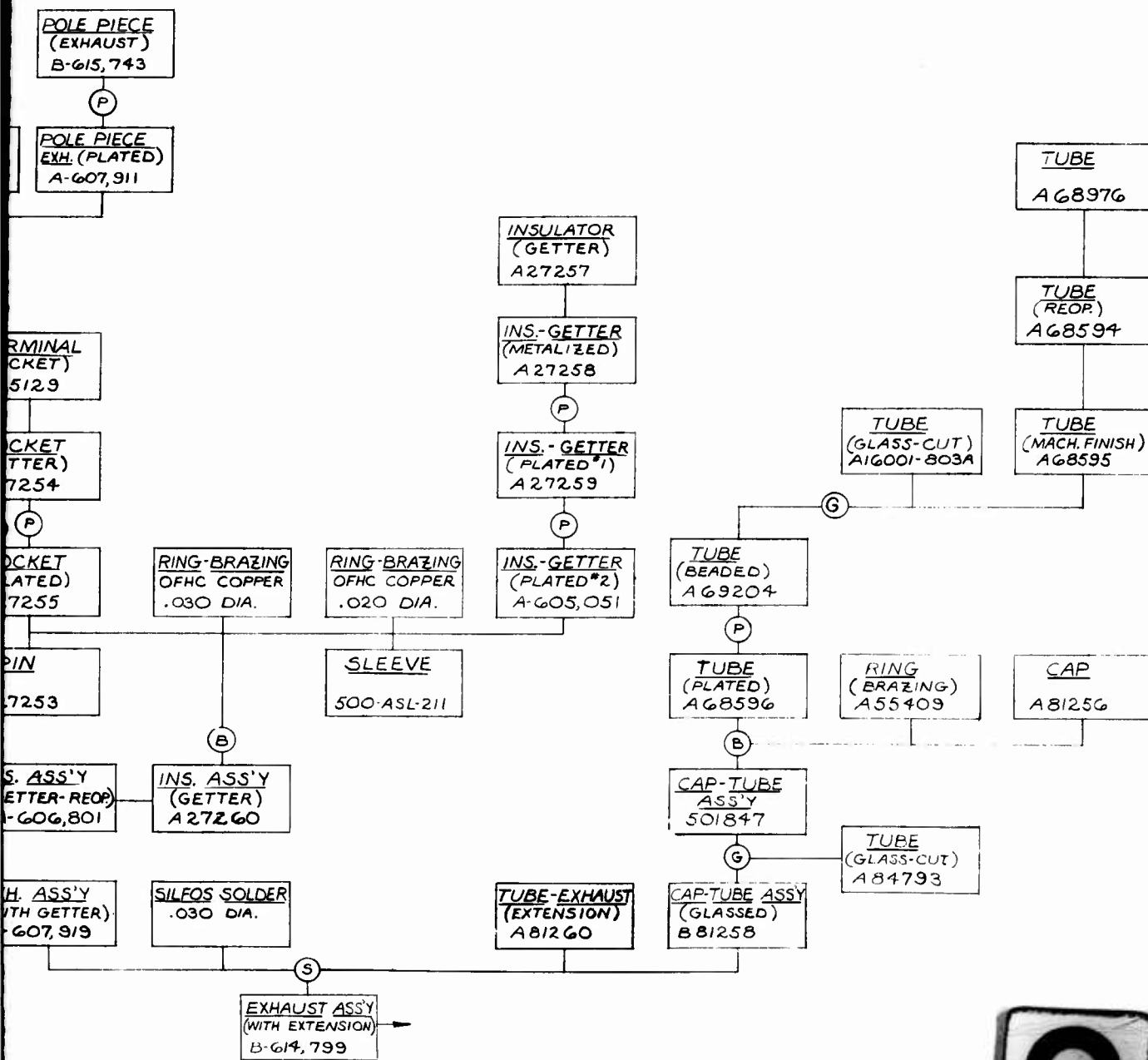

QKAB52 FLOW CHART (EXHAUST ASS'Y)



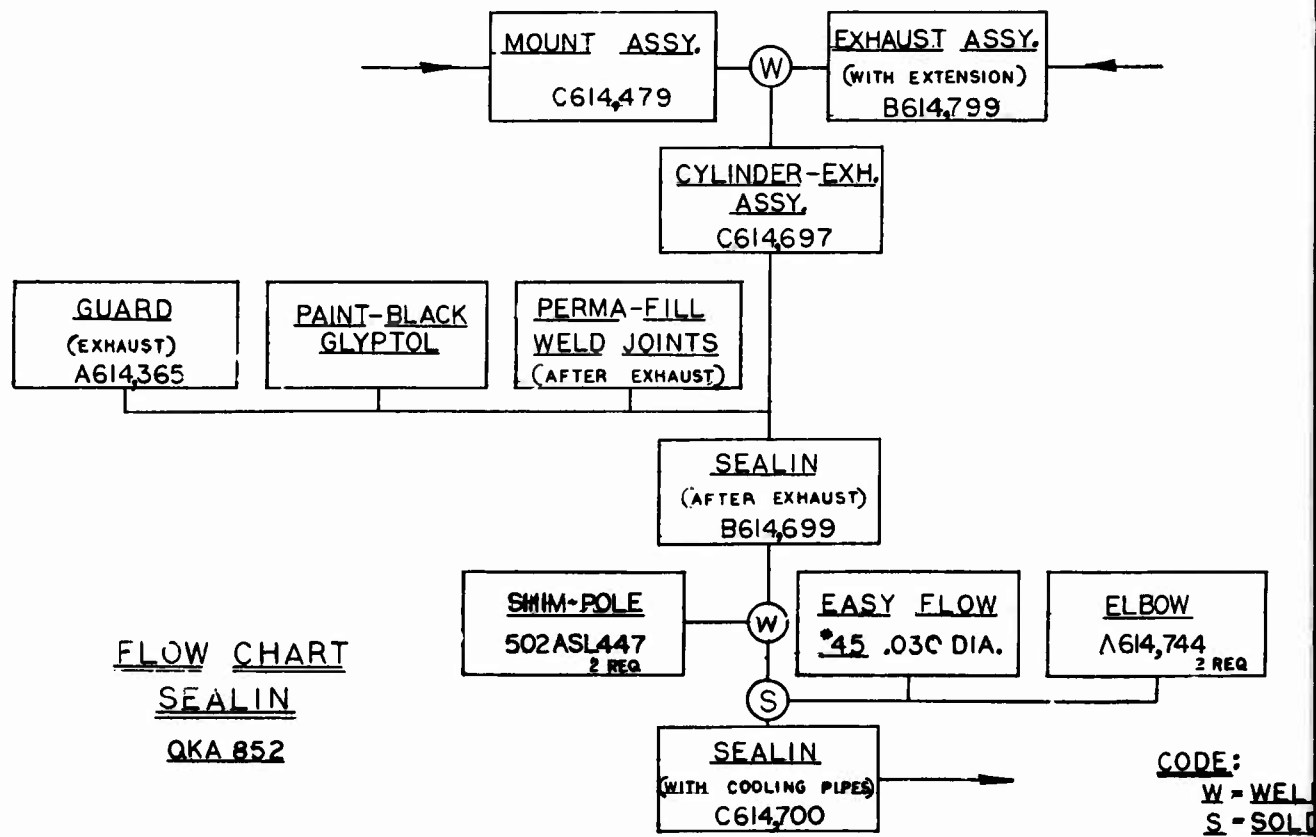

1

B 628,382
SHEET 6 OF 7

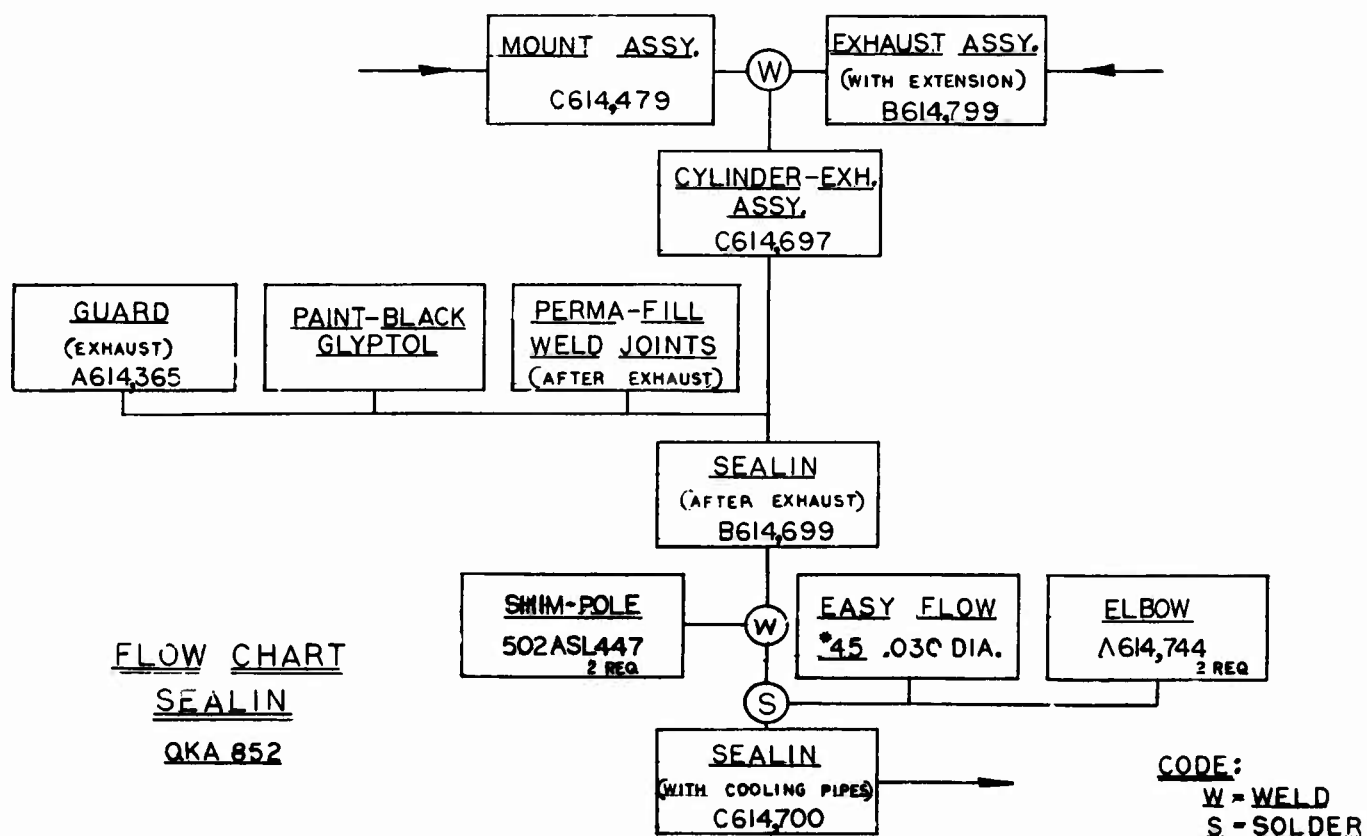

2

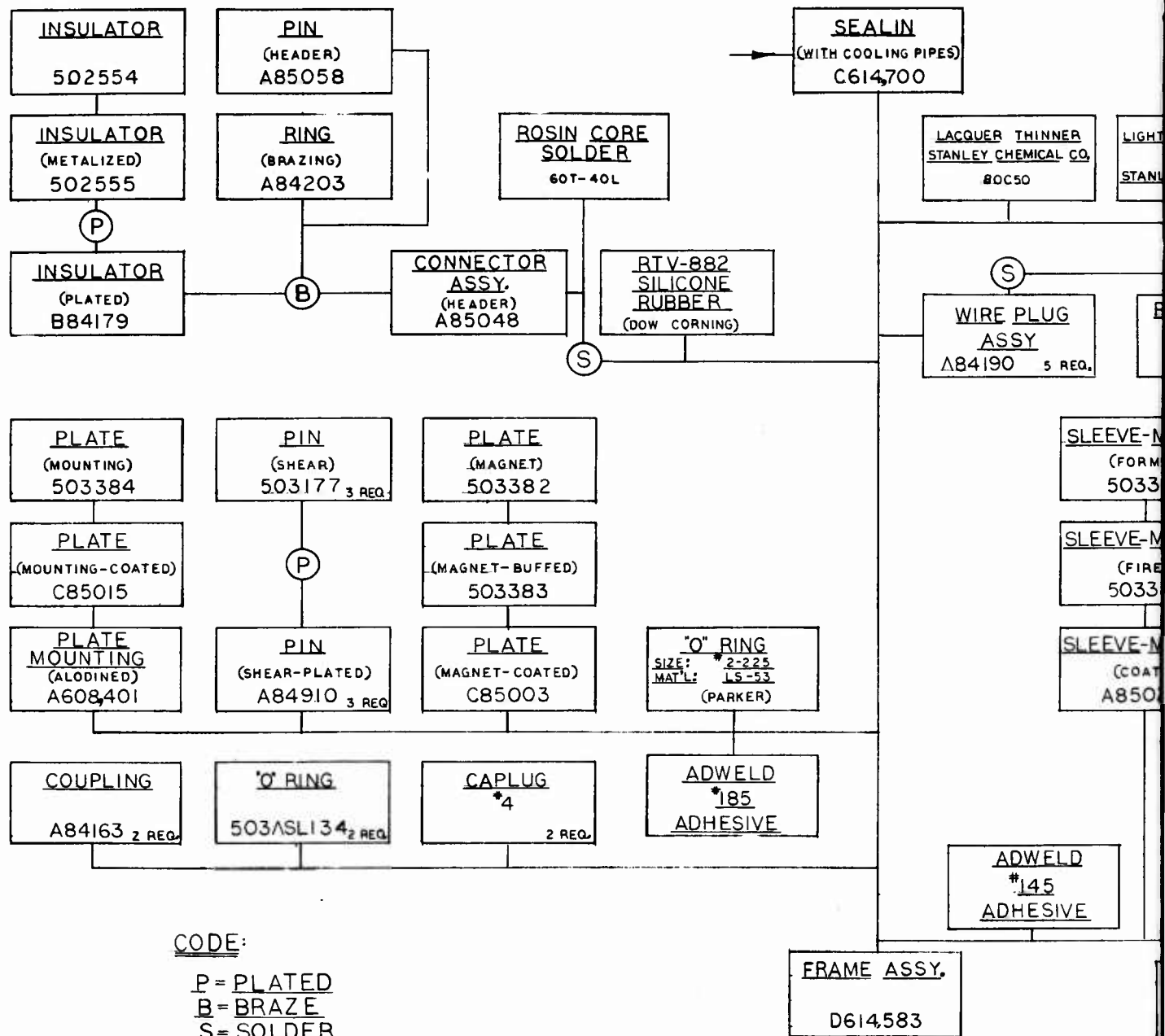

CODE:

P = PLATED
 B = BRAZE
 S = SOLDER
 W = WELD



FLOW CHART
FRAME ASSEMBLY
QKA 852

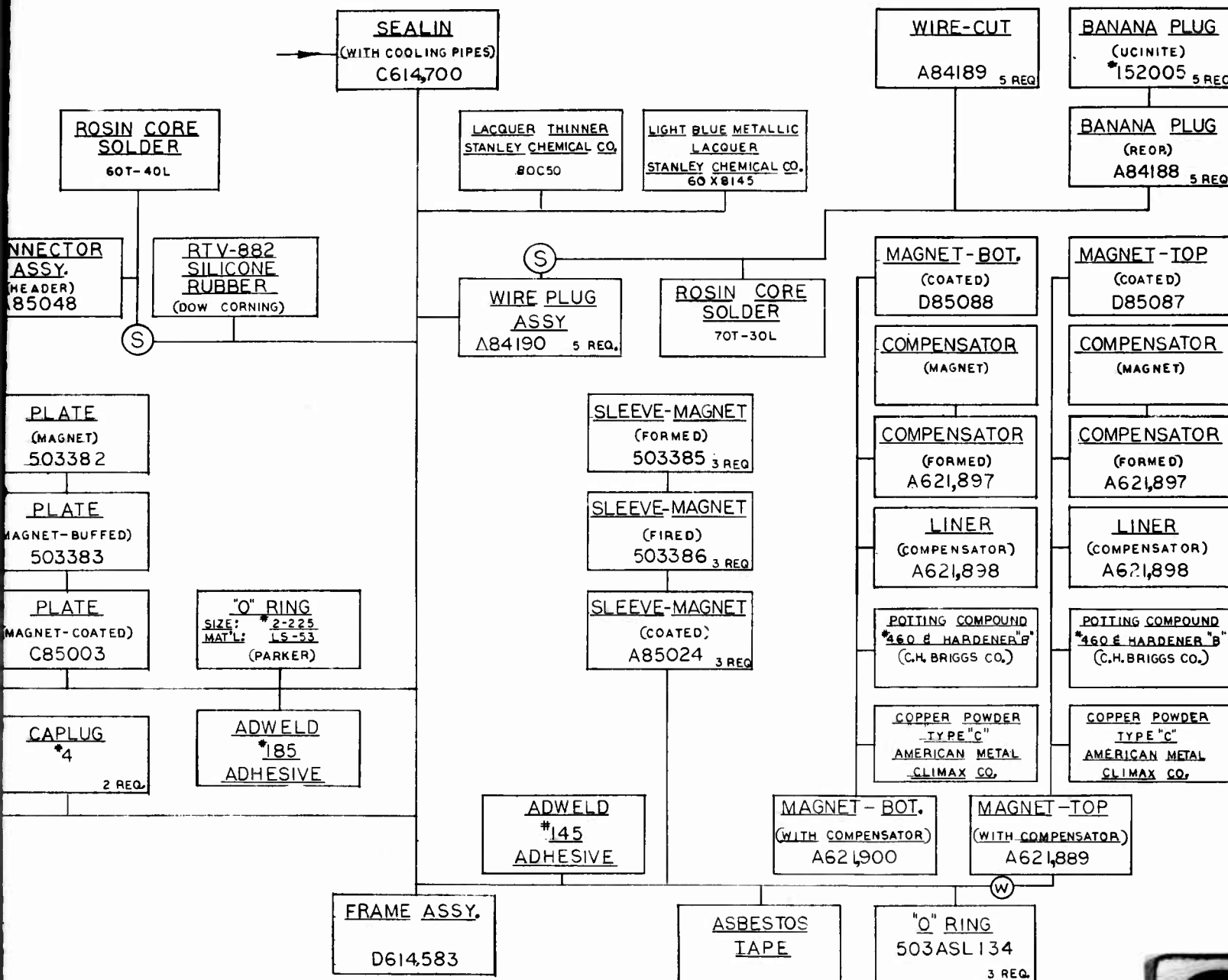

FLOW CHART
FRAME ASSEMBLY
QKA 852



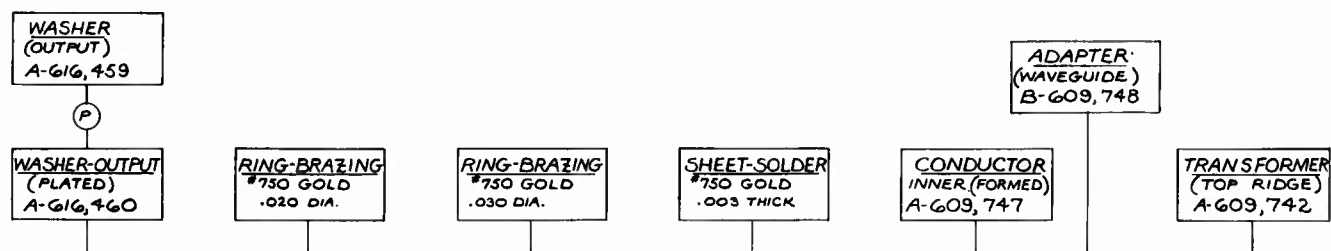
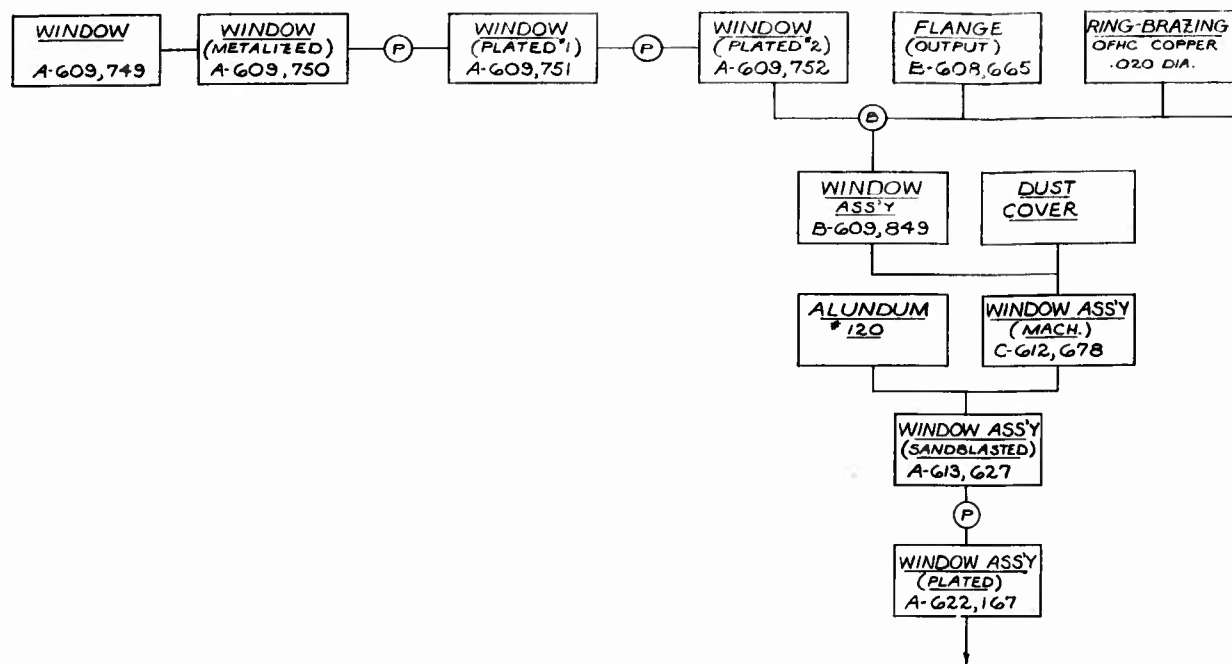

CODE:
P = PLATE
B = BRAZE



FLOW CHART
WINDOW ASSY (PLATED)
WAVEGUIDE ASSY (MACH.)
QKA857

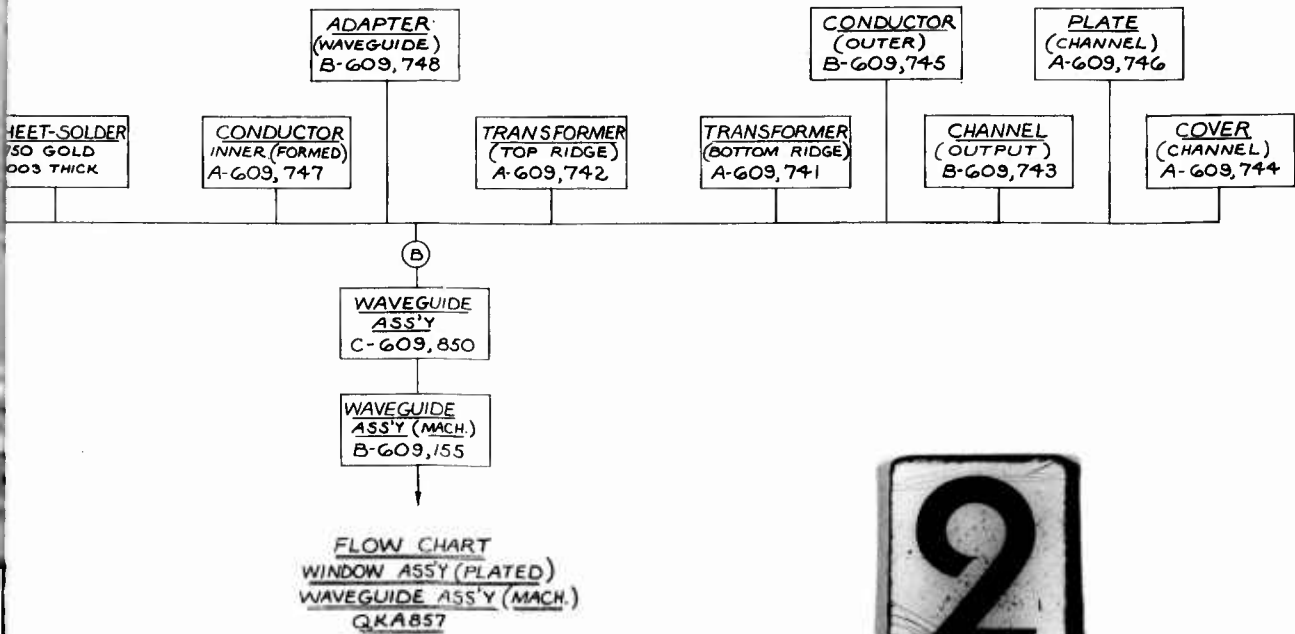
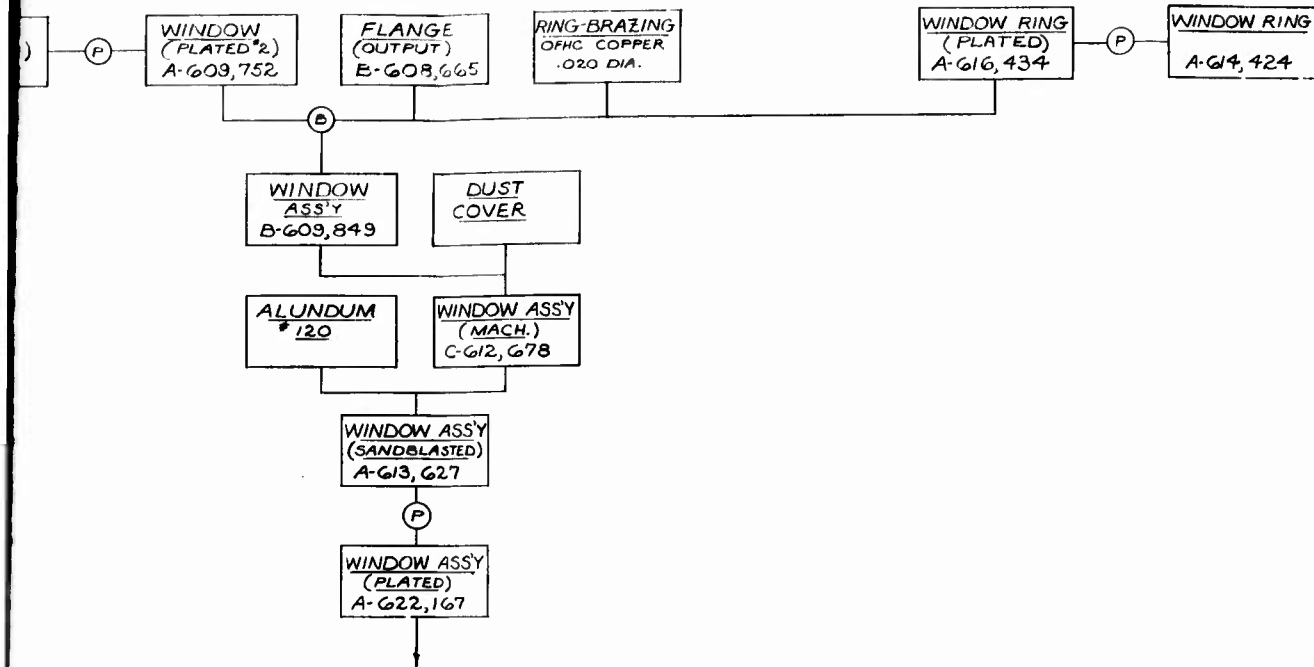

2

7

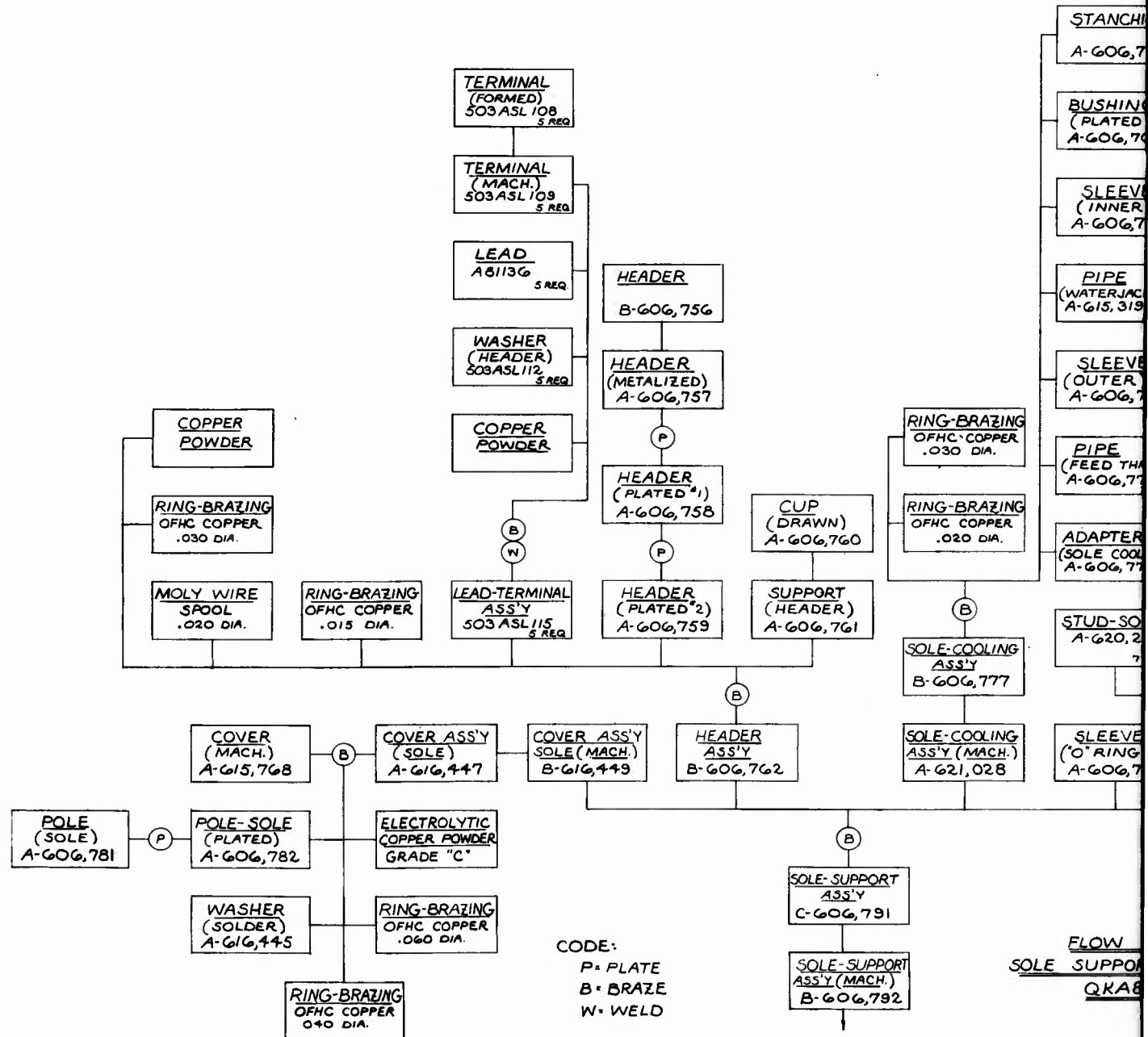

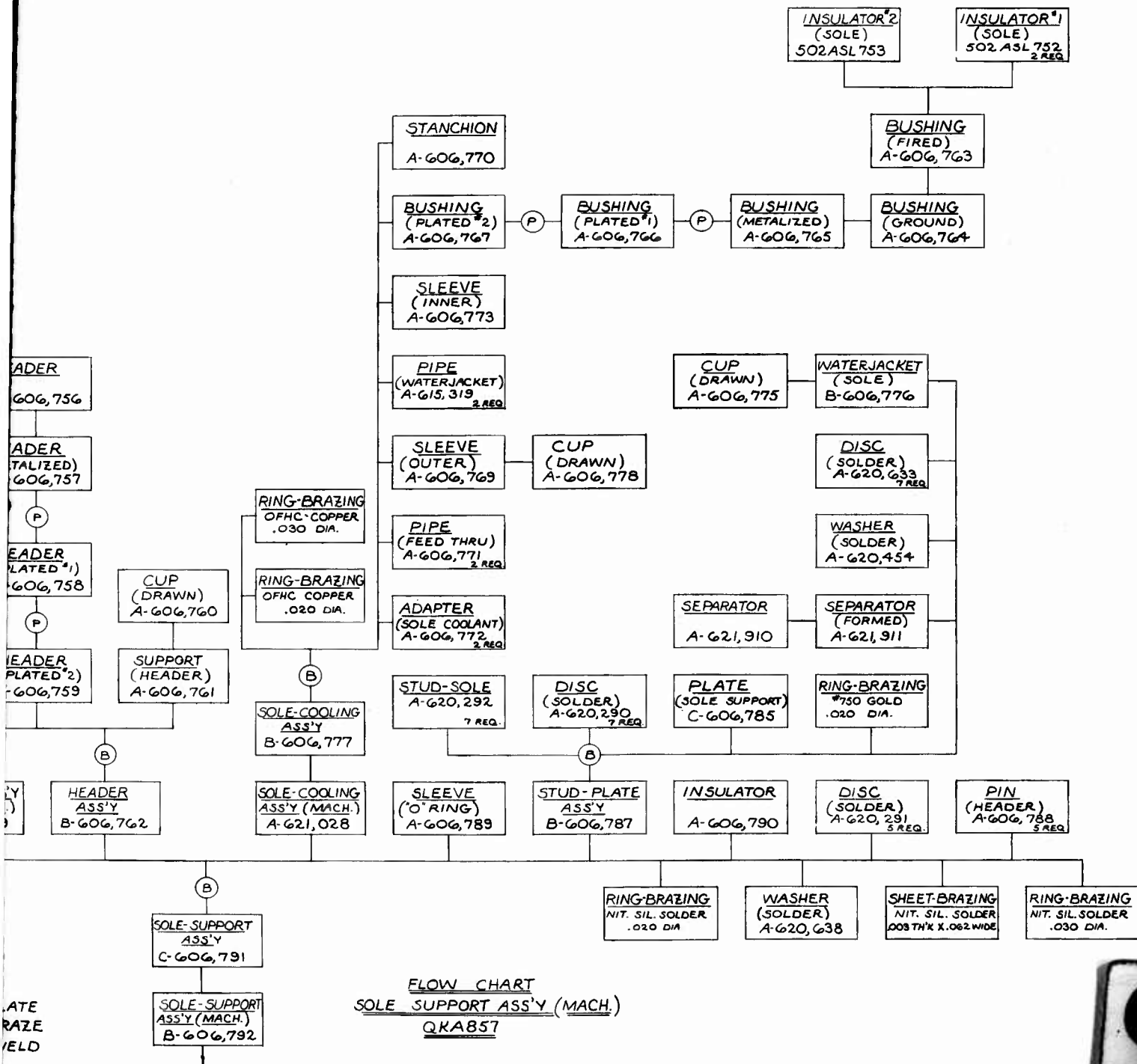

FLOW CHART
SOLE SUPPORT ASS'Y (MACH.)
QKAB57

2

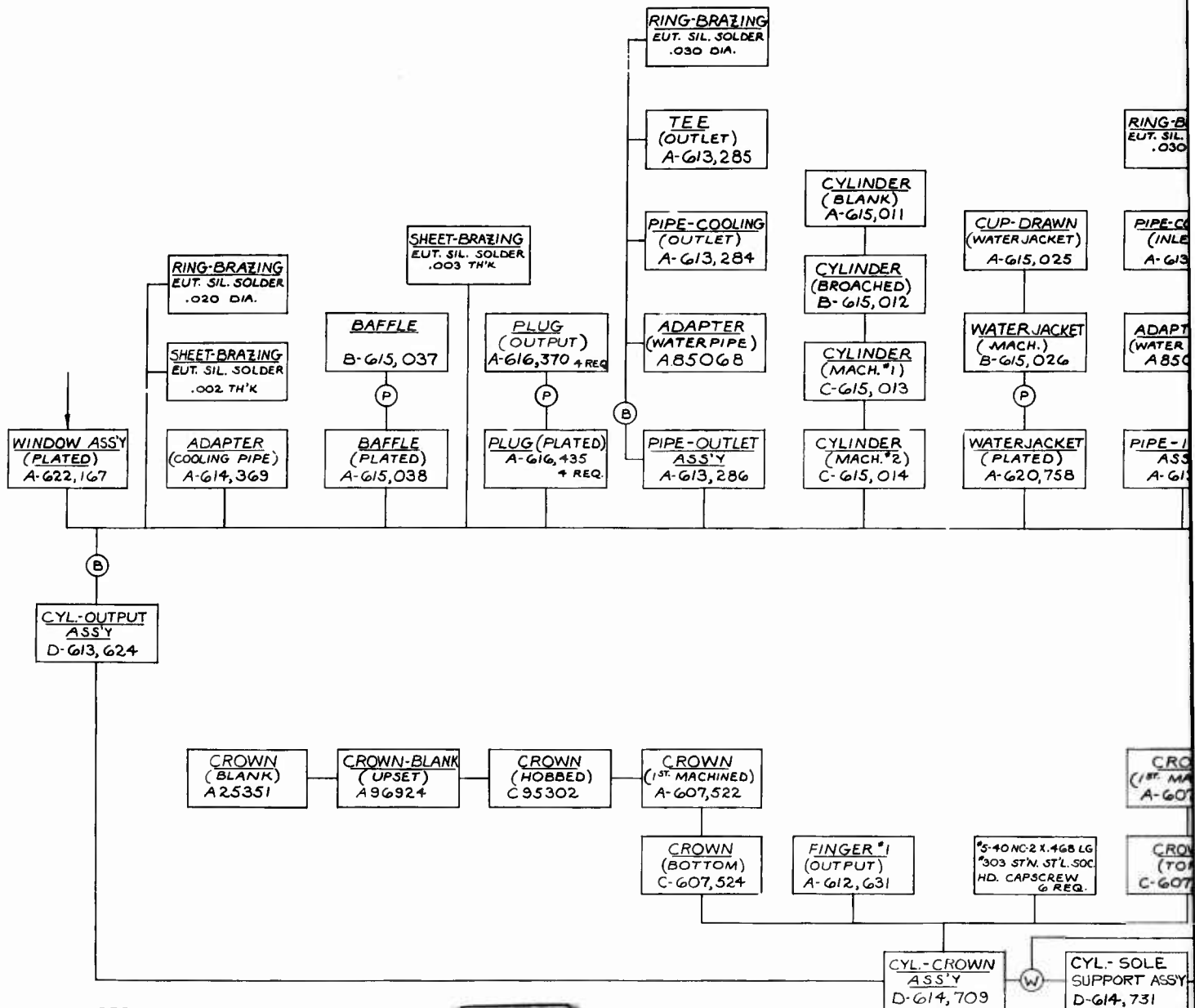

FLOW CHART
CYL.-SOLE SUPPORT ASS'Y
QKA 857



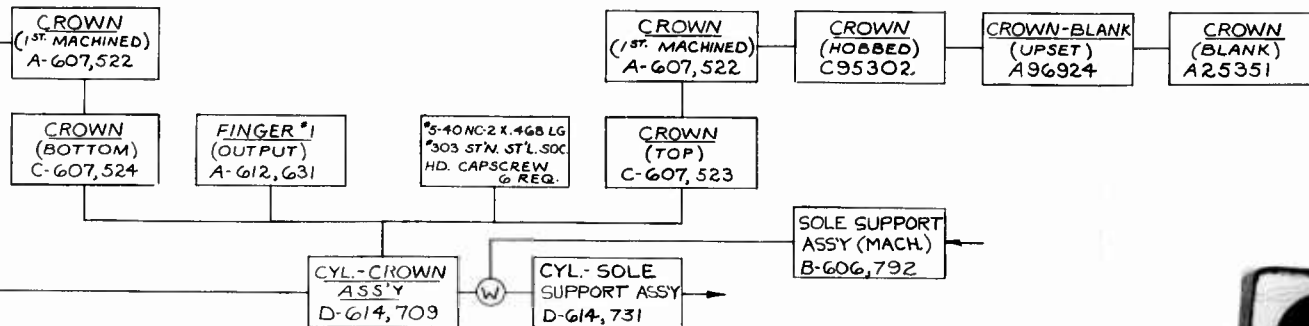
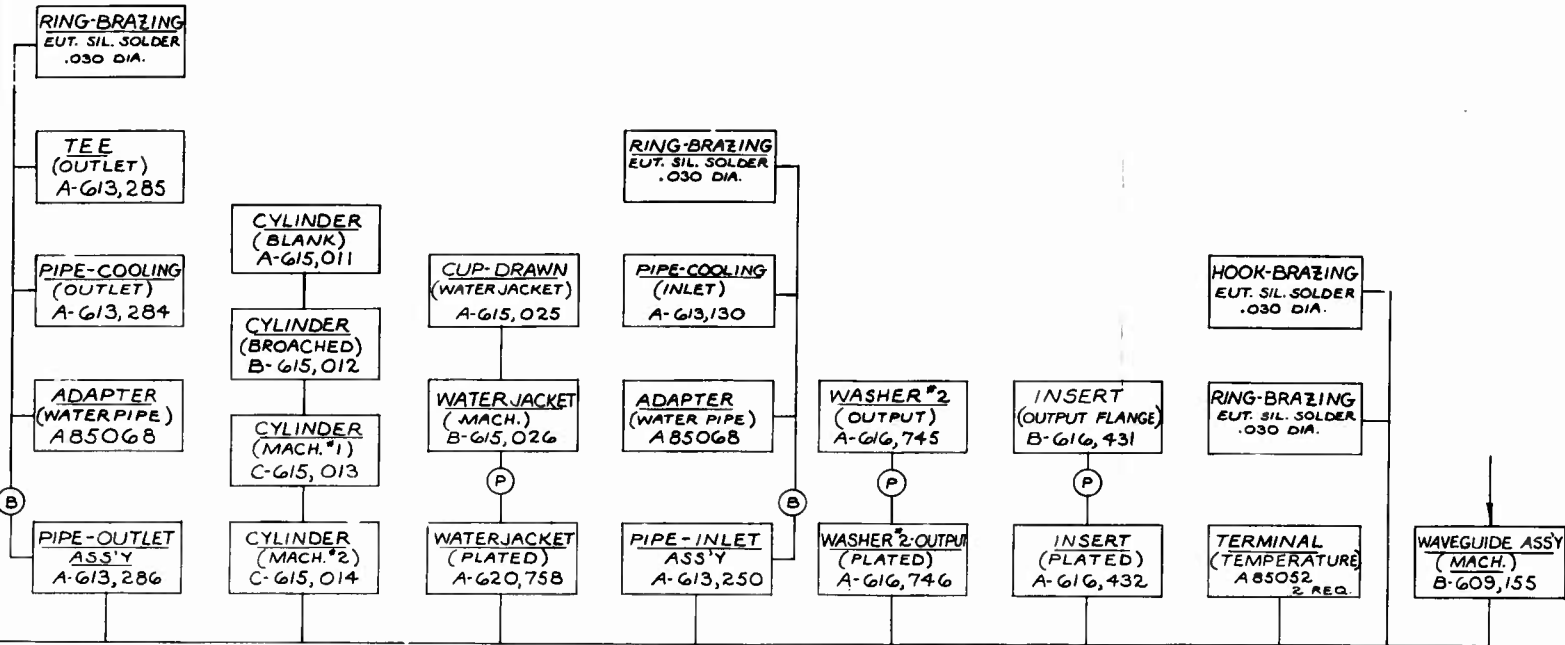

FLOW CHART
CYL.-SOLE SUPPORT ASS'Y
QKA857



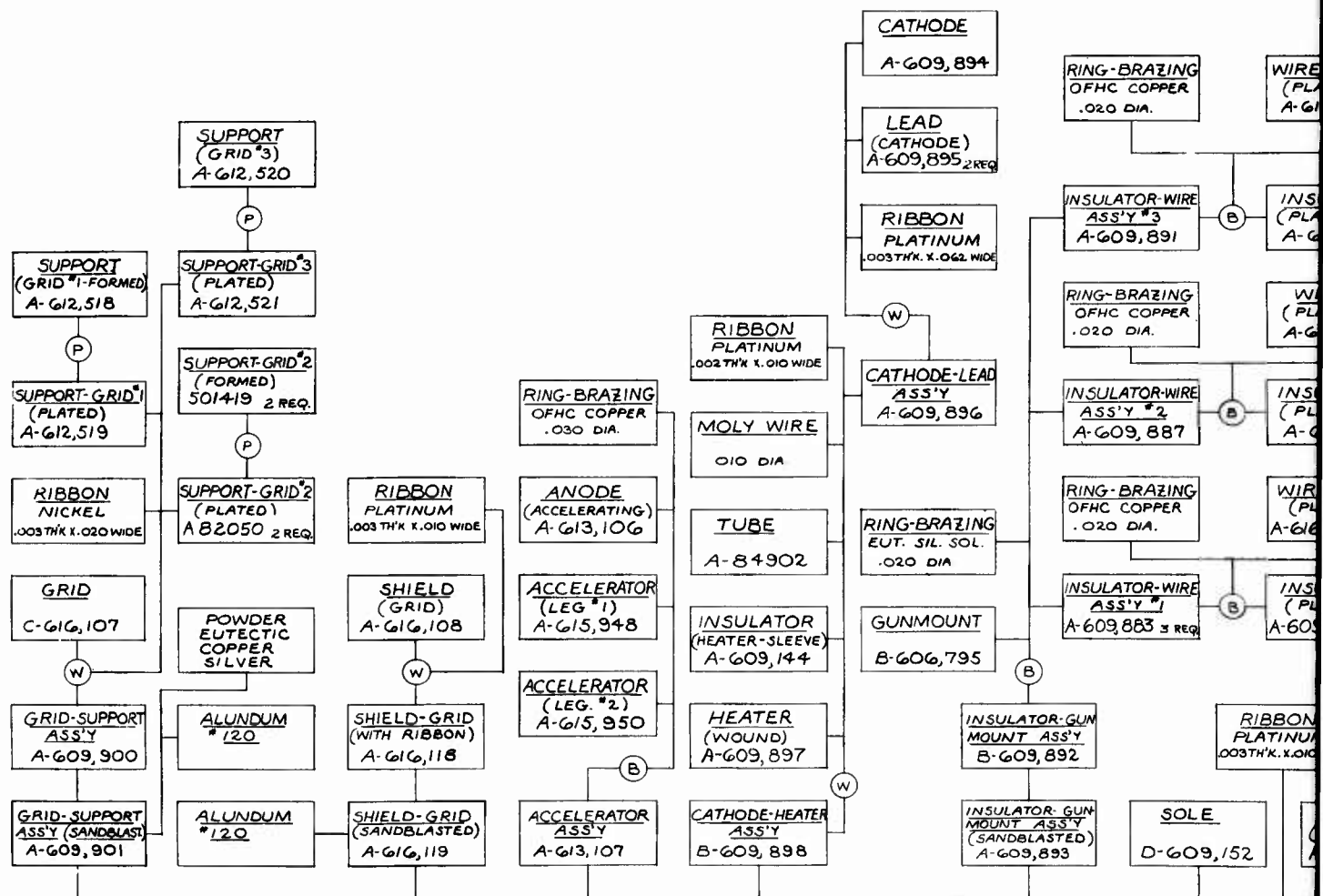

CODE:

B- BRAZE
 P- PLATE
 W- WELD

1

FLOW CHART
 SOLE-GUN ASS'Y
 QKA 857

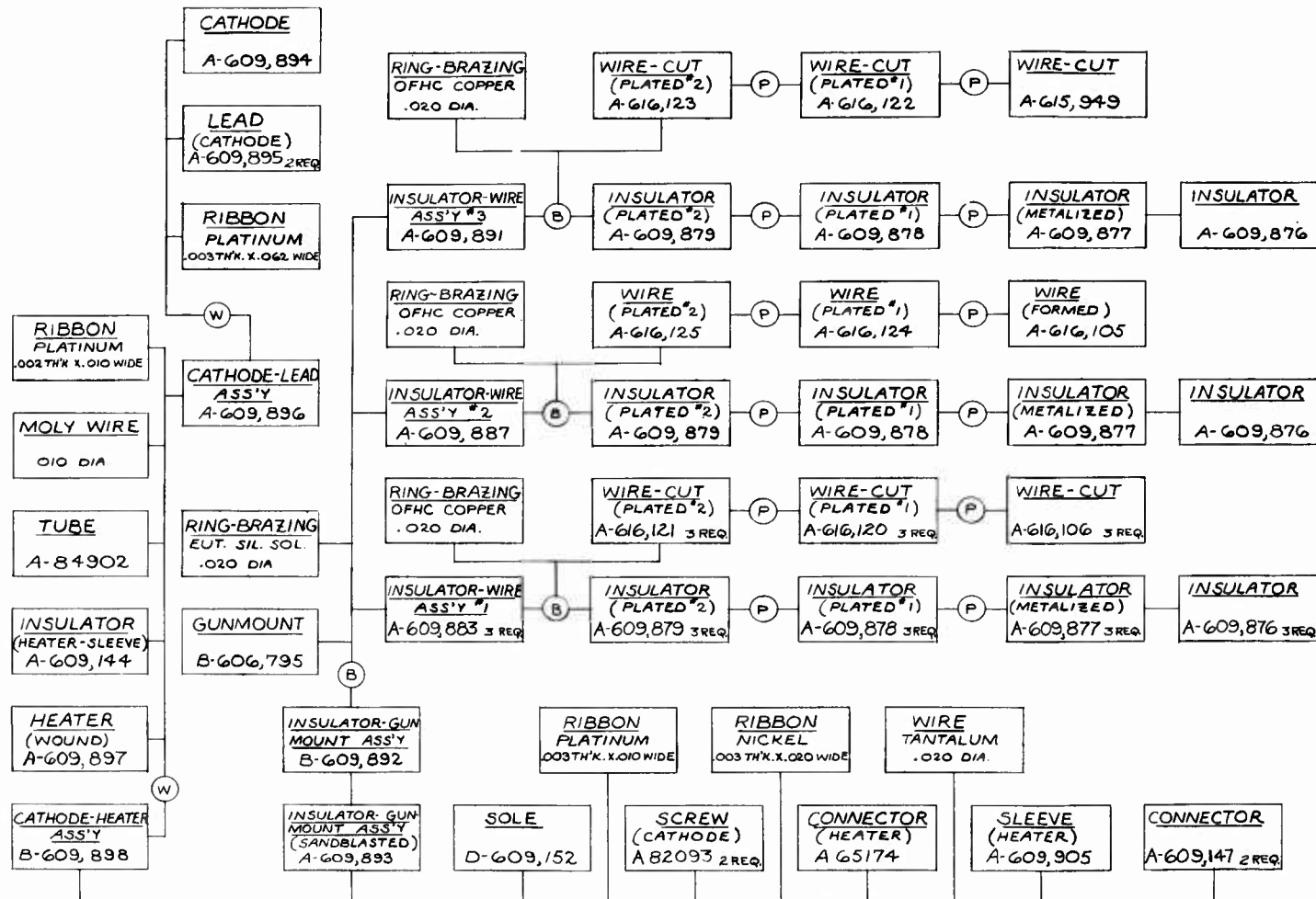

SOLE-GUN
ASS'Y
D-612,632

FLOW CHART
SOLE-GUN ASS'Y
QKA857



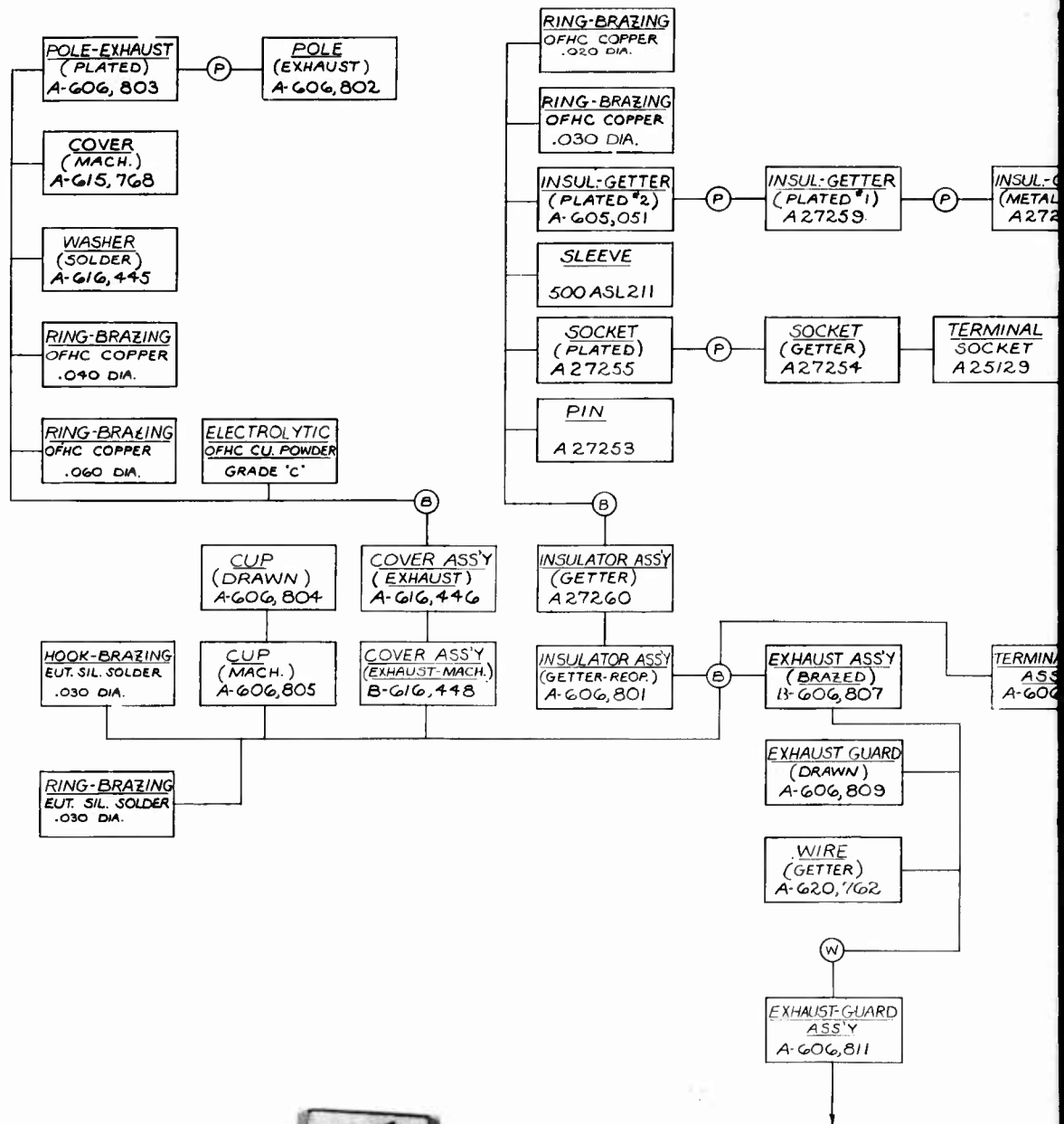

CODE:

B • BRAZE
W • WELD
P • PLATE



FLOW CHART
EXHAUST-GUARD ASSY
QKA857

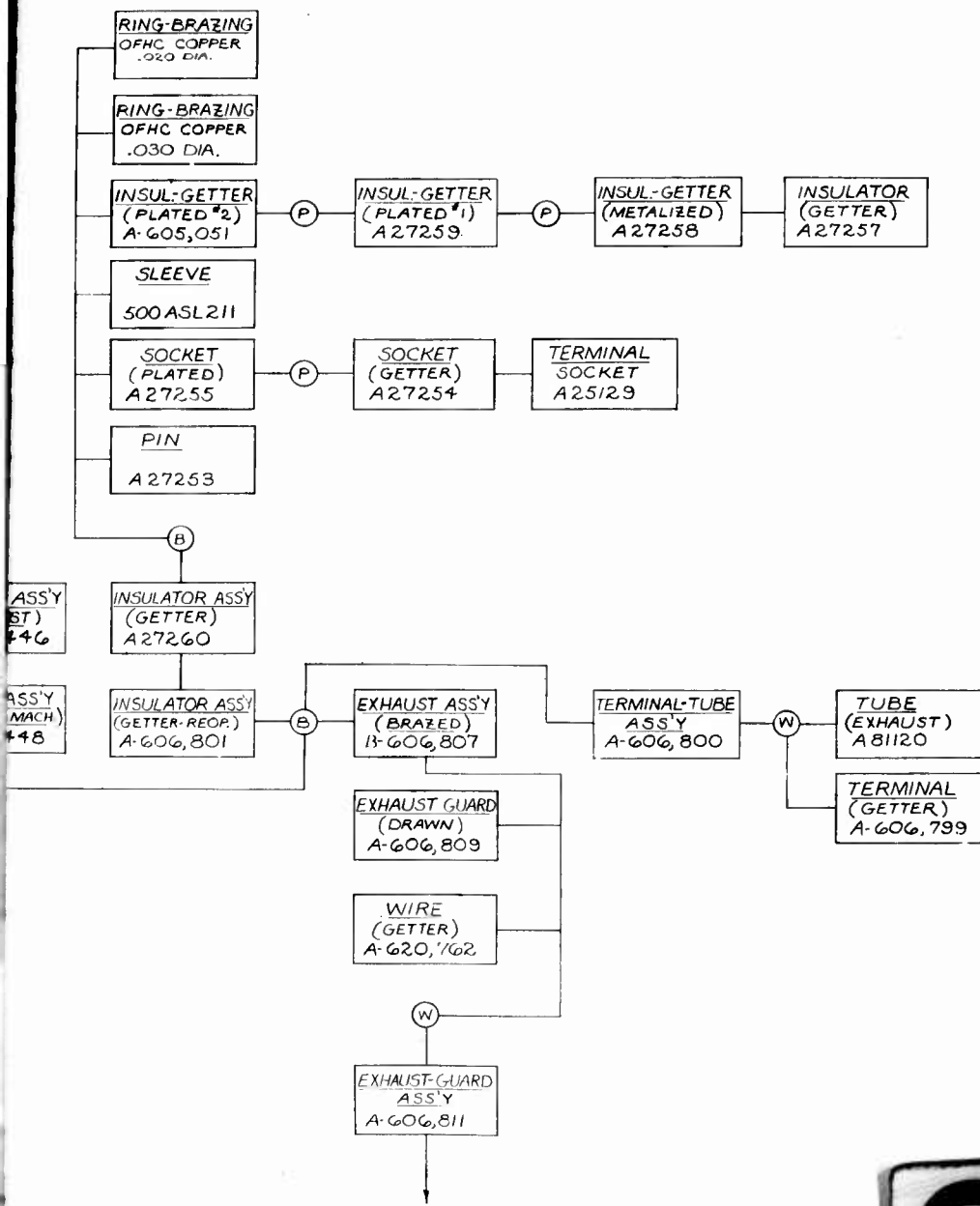

FLOW CHART
EXHAUST-GUARD ASS'Y
QKA857

2

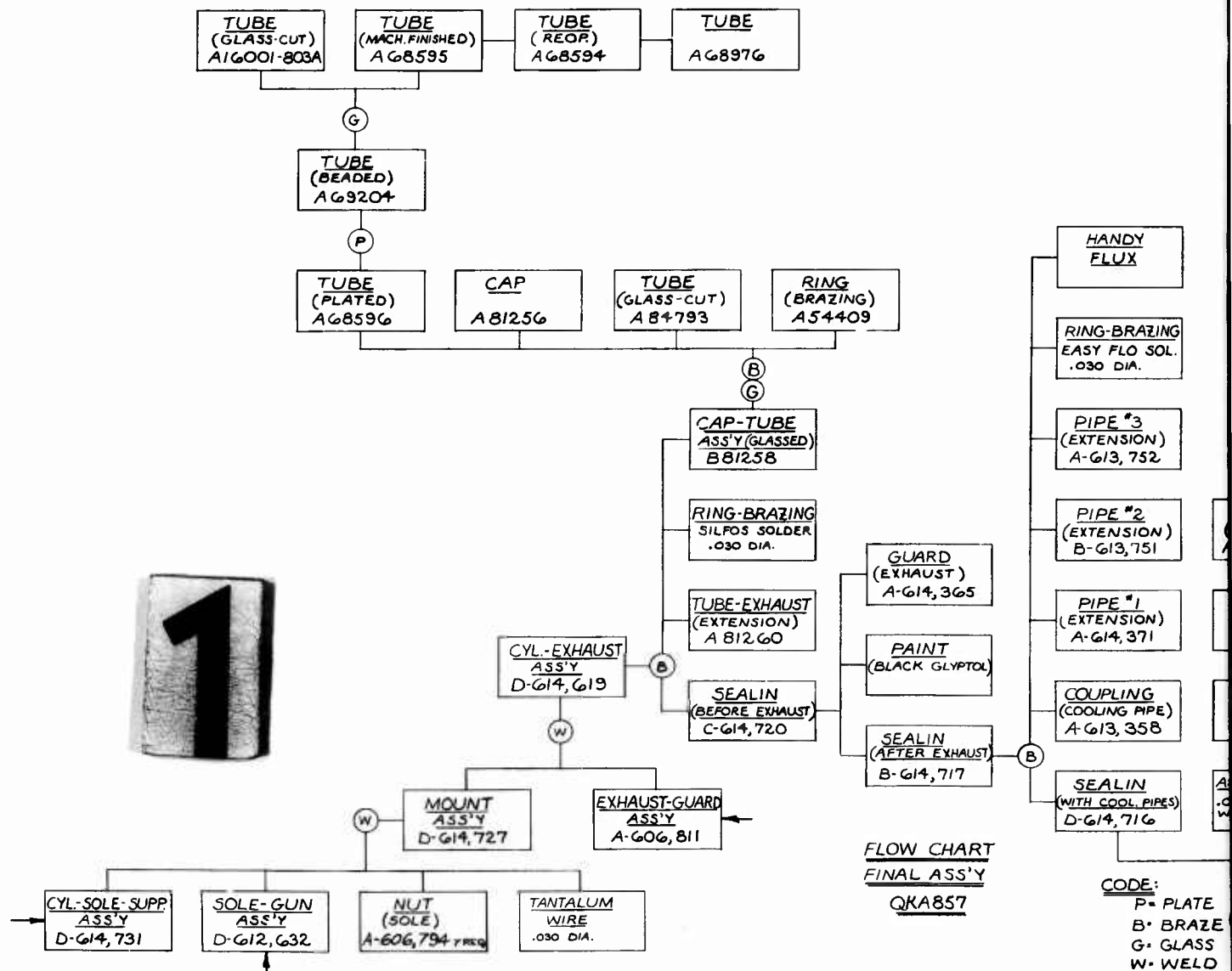

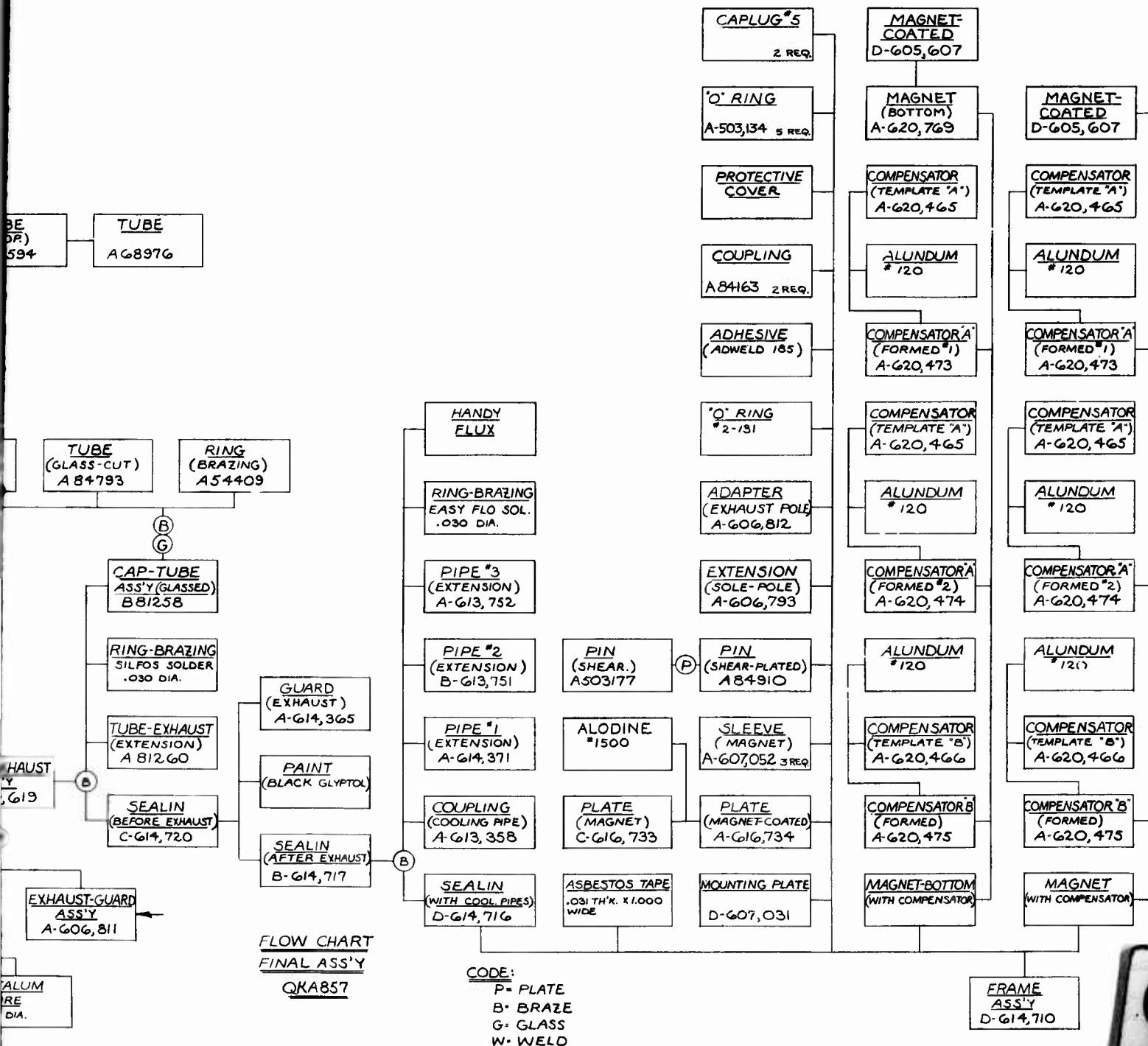

FLOW CHART
FINAL ASS'Y
QKA857

CODE:
P= PLATE
B= BRAZE
G= GLASS
W= WELD



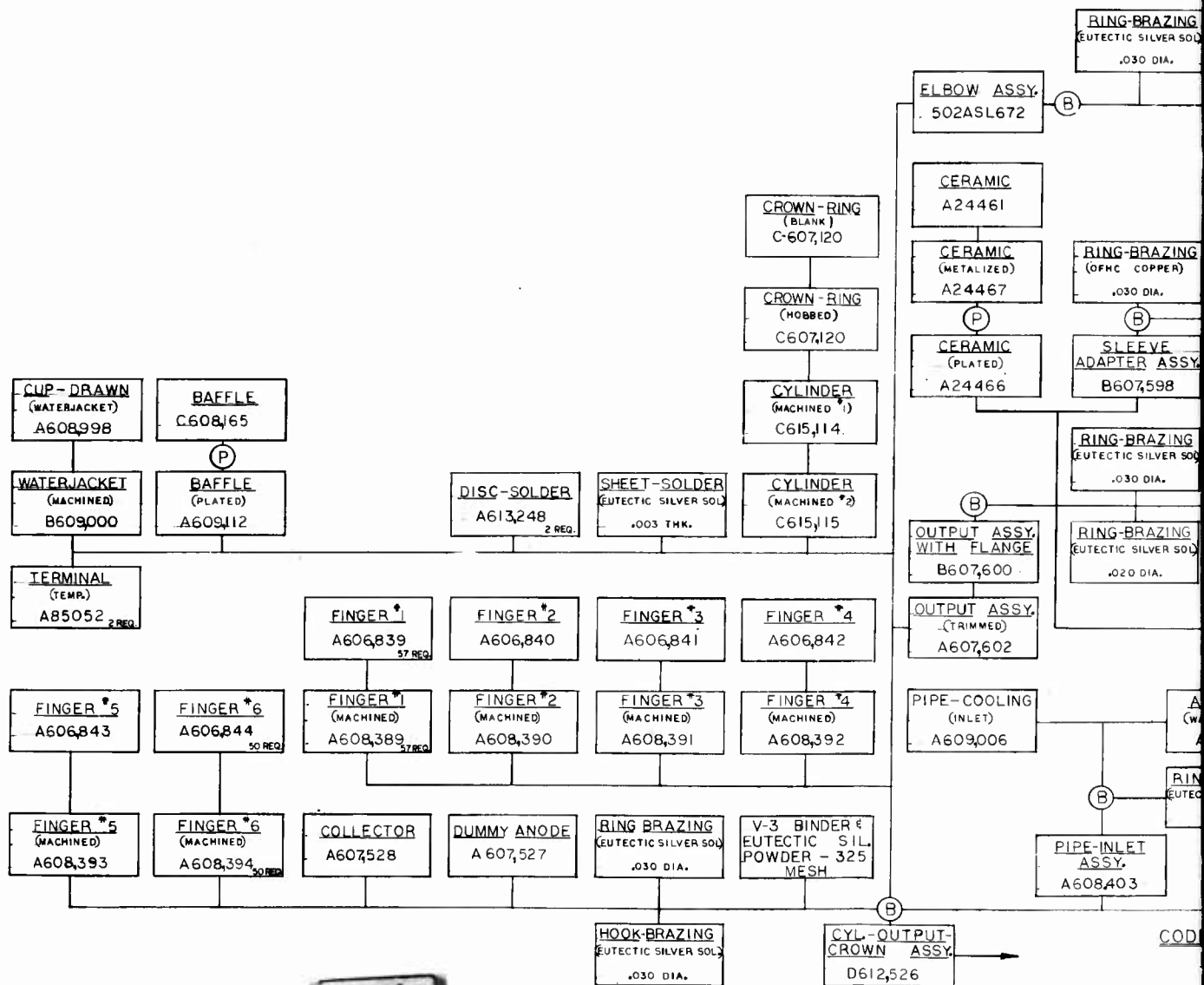

FLOW CHART
CYLINDER OUTPUT CROWN ASSY.
QKA 851

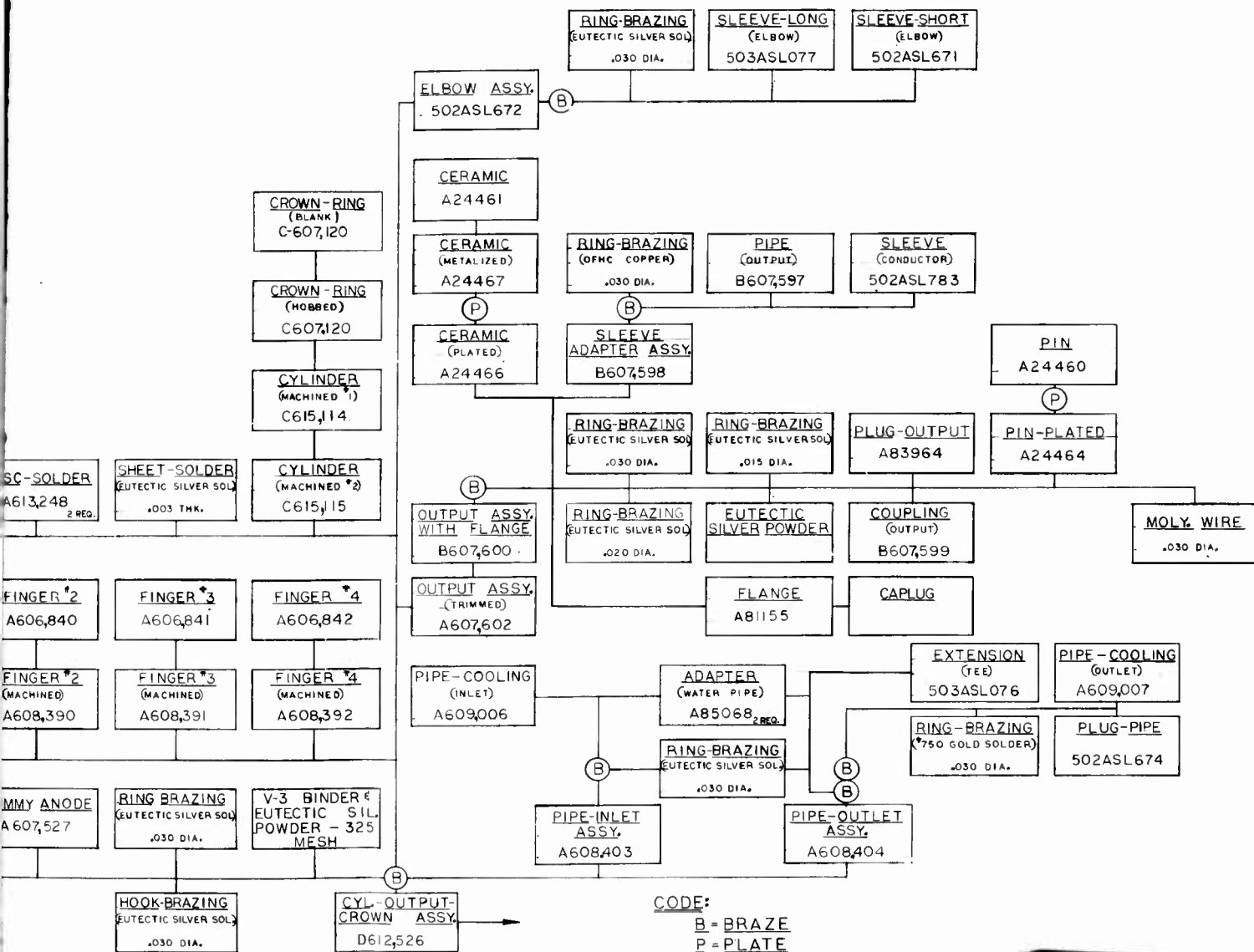

FLOW CHART
CYLINDER OUTPUT CROWN ASSY.

QKA 851

2

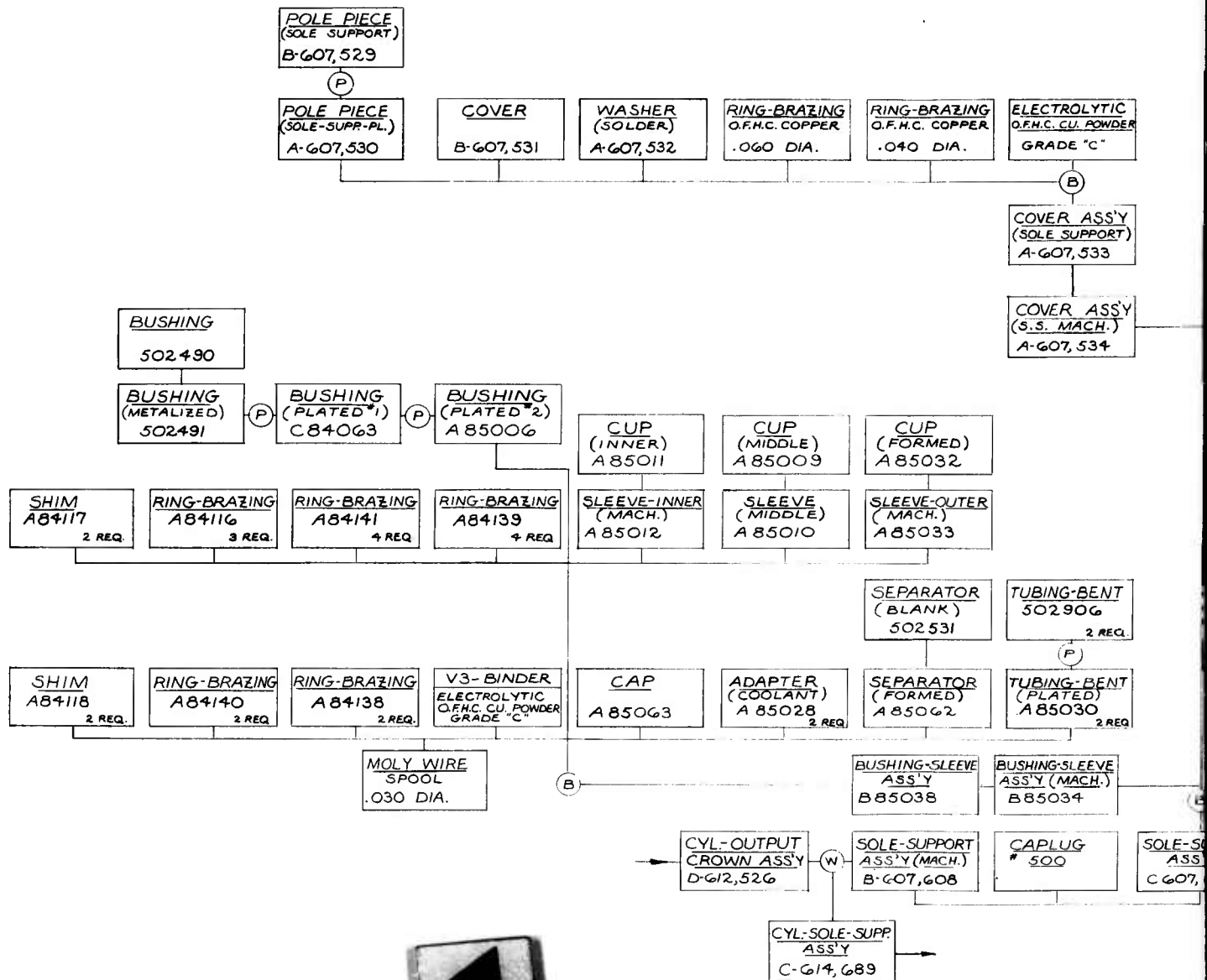

FLOW CHART
(CYL. SOLE SUPPORT ASS'Y)
QK851

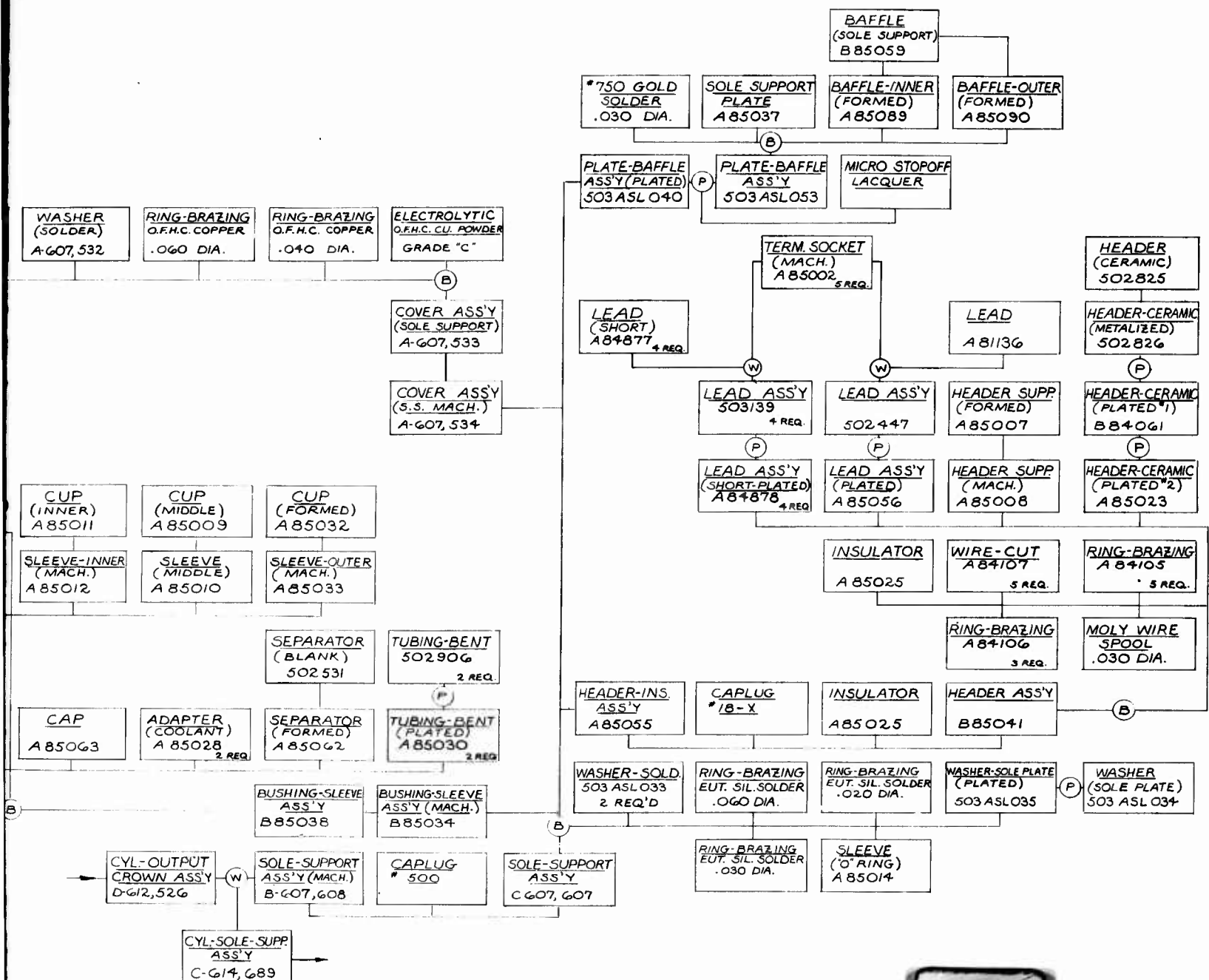

FLOW CHART
(CYL. SOLE SUPPORT ASS'Y)
QK851



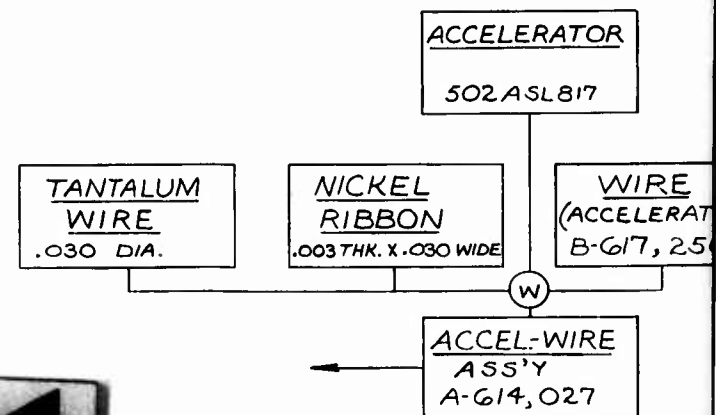
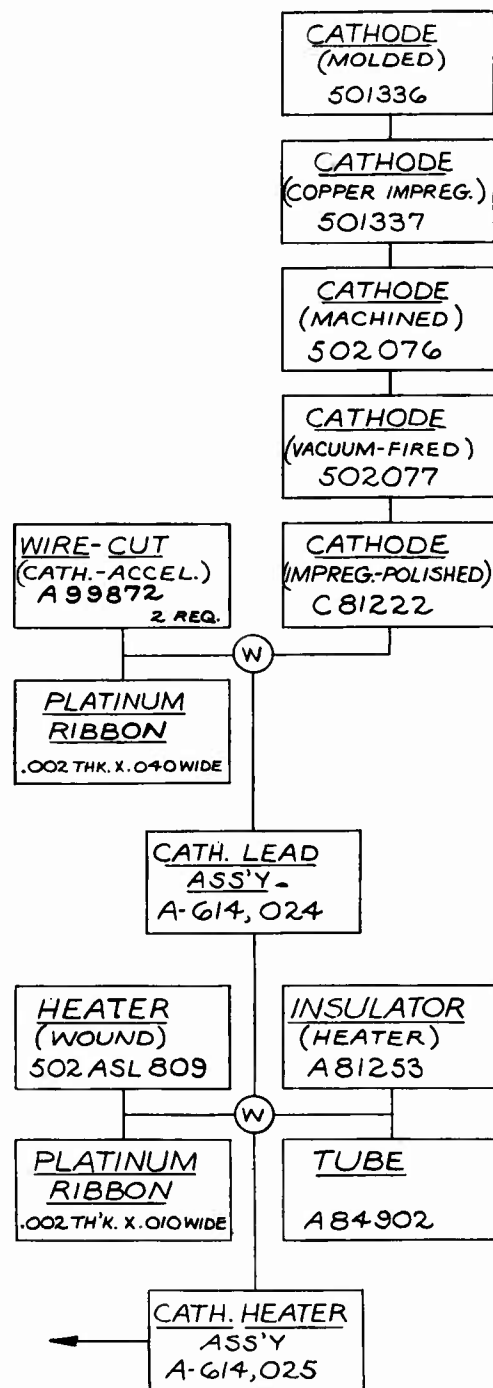

FLOW CHART
GUN ASS'Y
QKA851

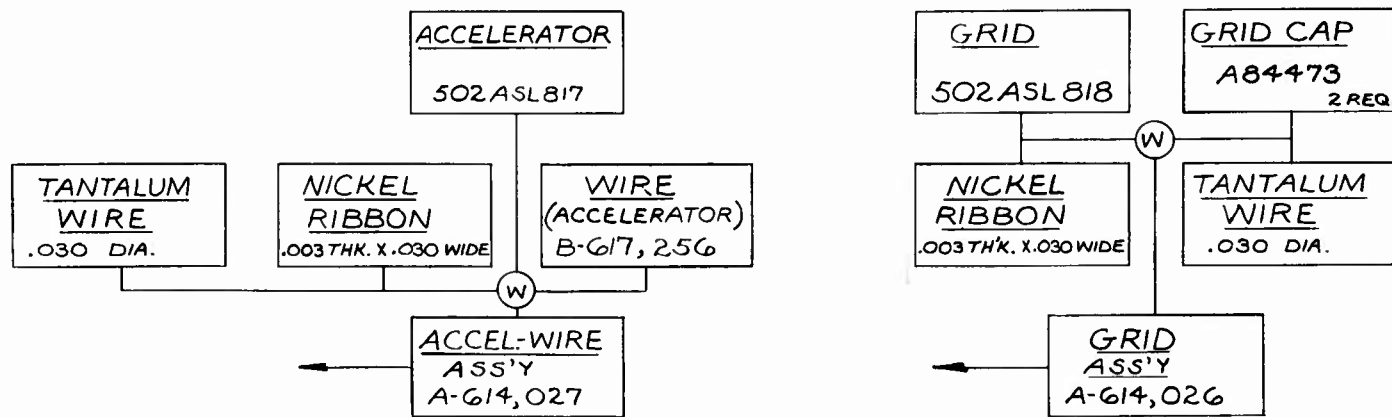

FLOW CHART
GUN ASS'Y
QKA851

2

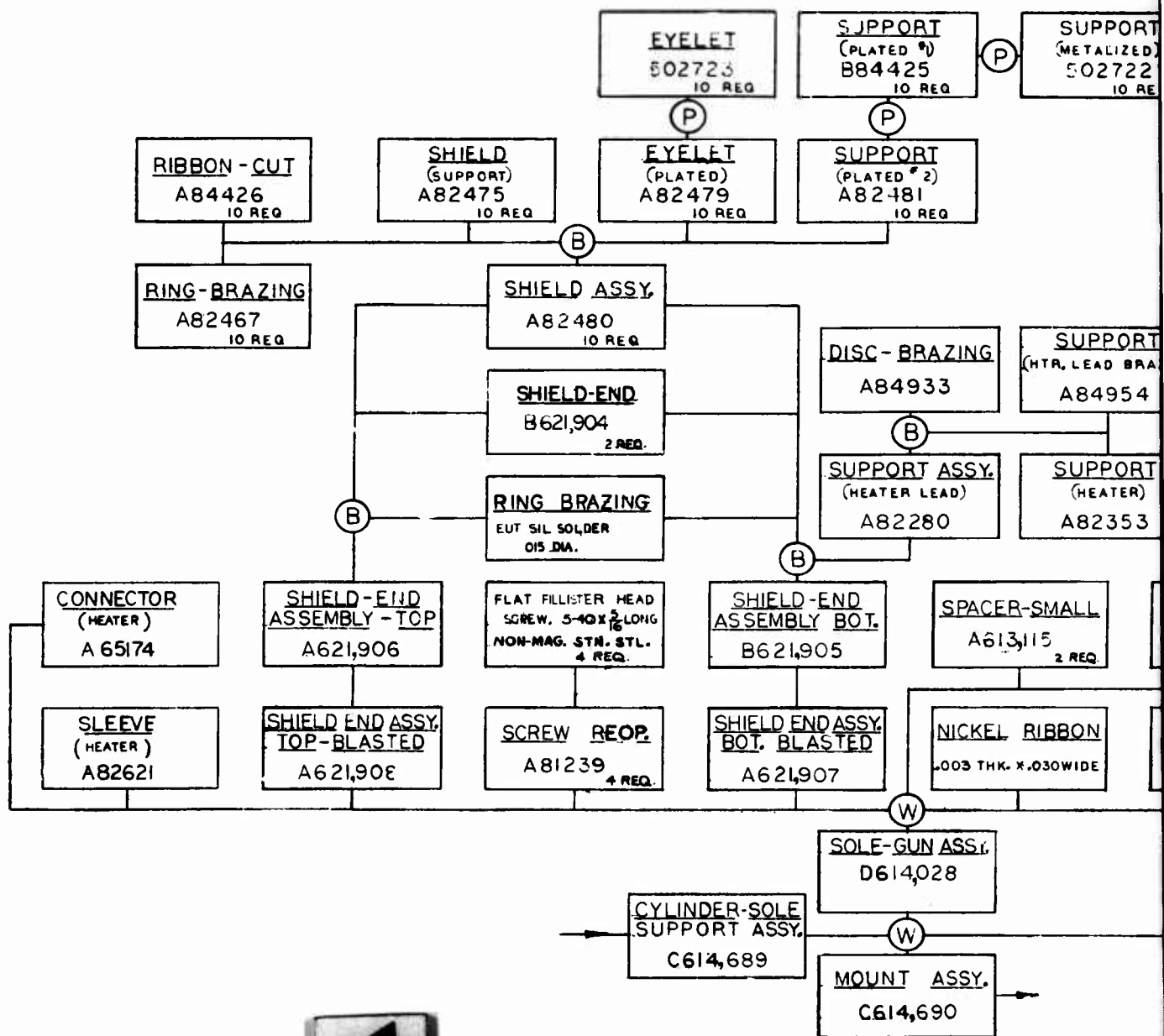

FLOW CHART
MOUNT ASSEMBLY
QKA 851

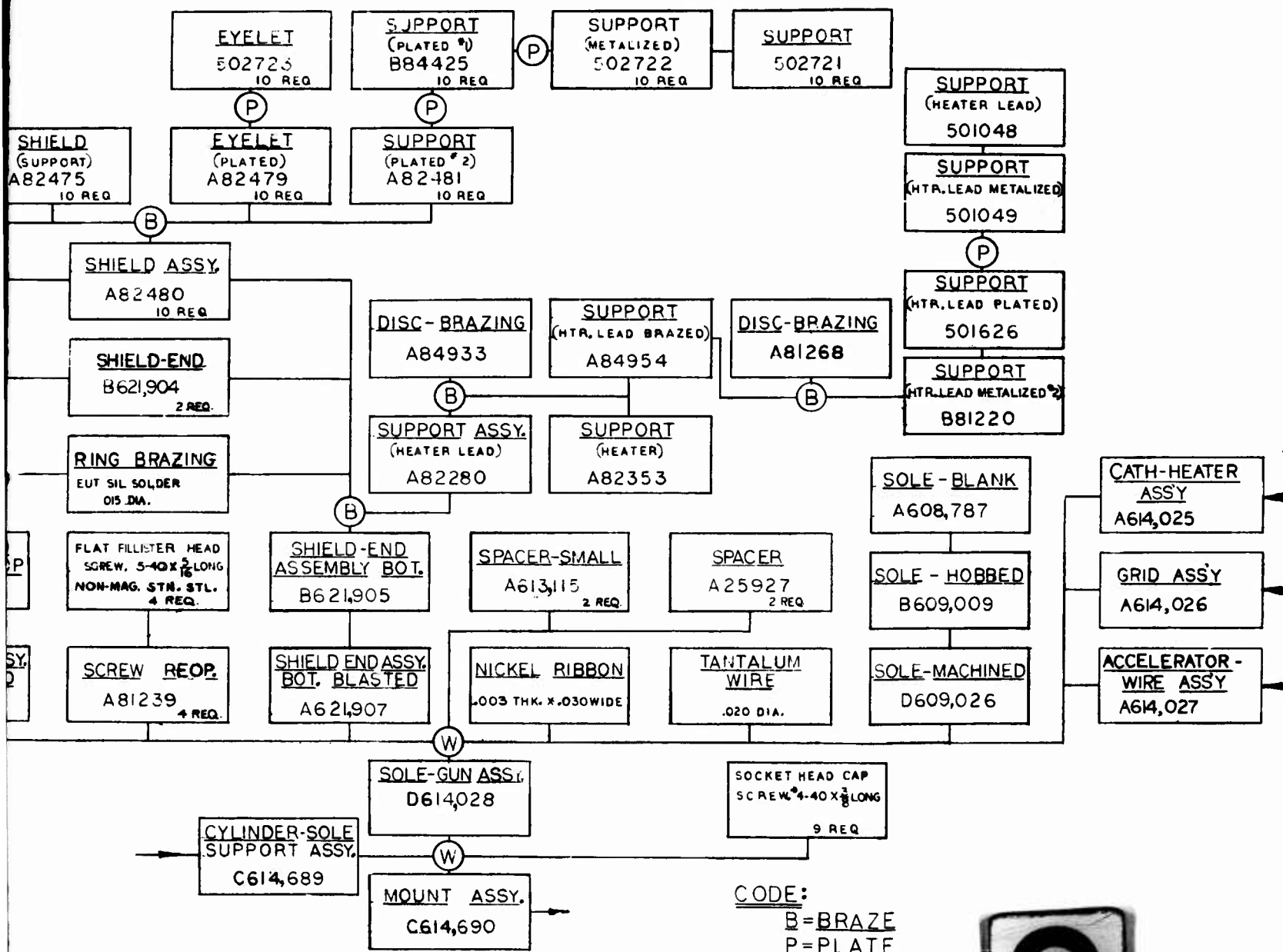

FLOW CHART
MOUNT ASSEMBLY
QKA 851

CODE:
B=BRAZE
P=PLATE
W=WELD

2

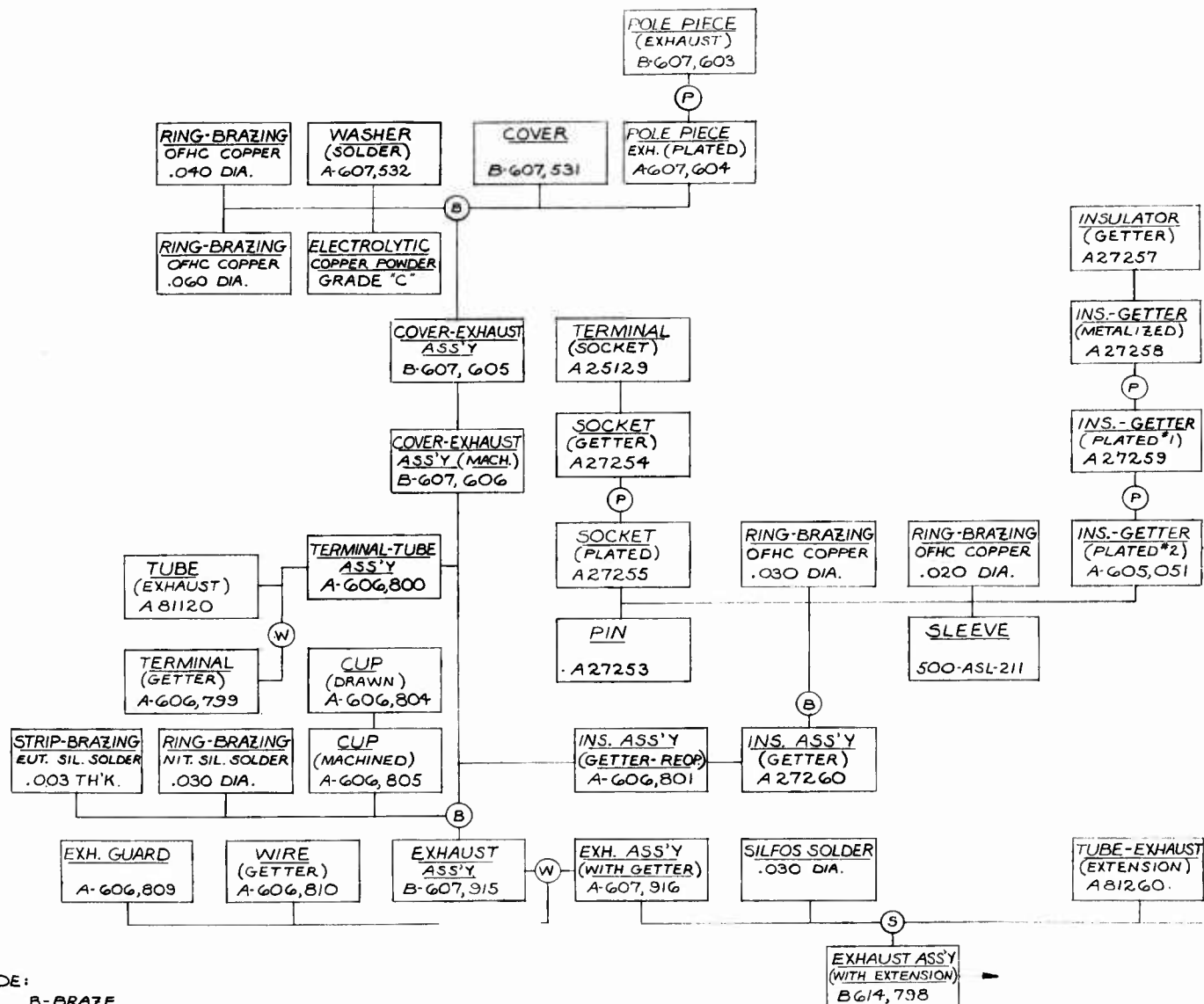

FLOW CHART
 (EXHAUST ASS'Y (WITH EXTENSION))
 QKA 851

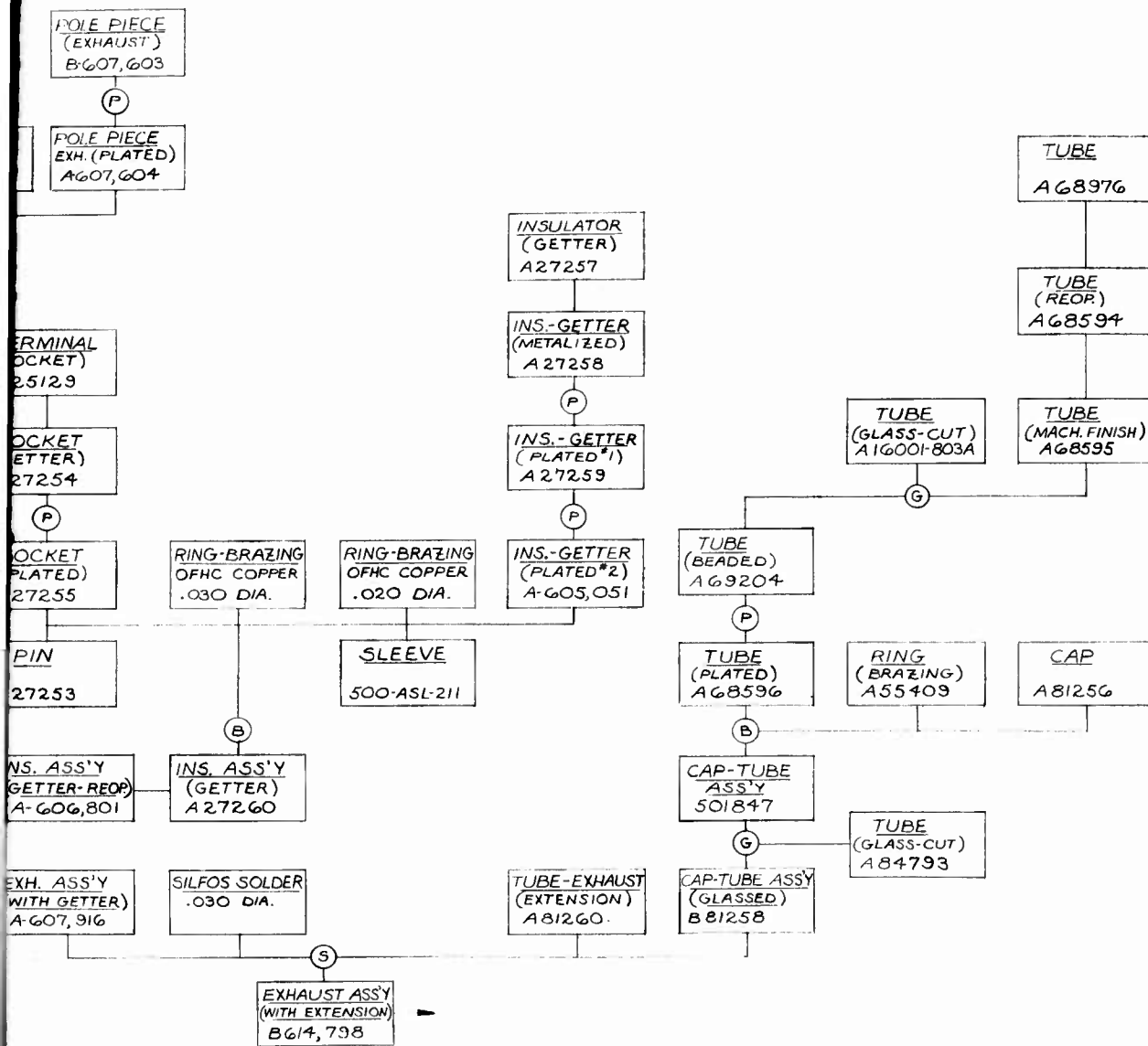

FLOW CHART
(EXHAUST ASSY (WITH EXTENSION))
QKA 851

2

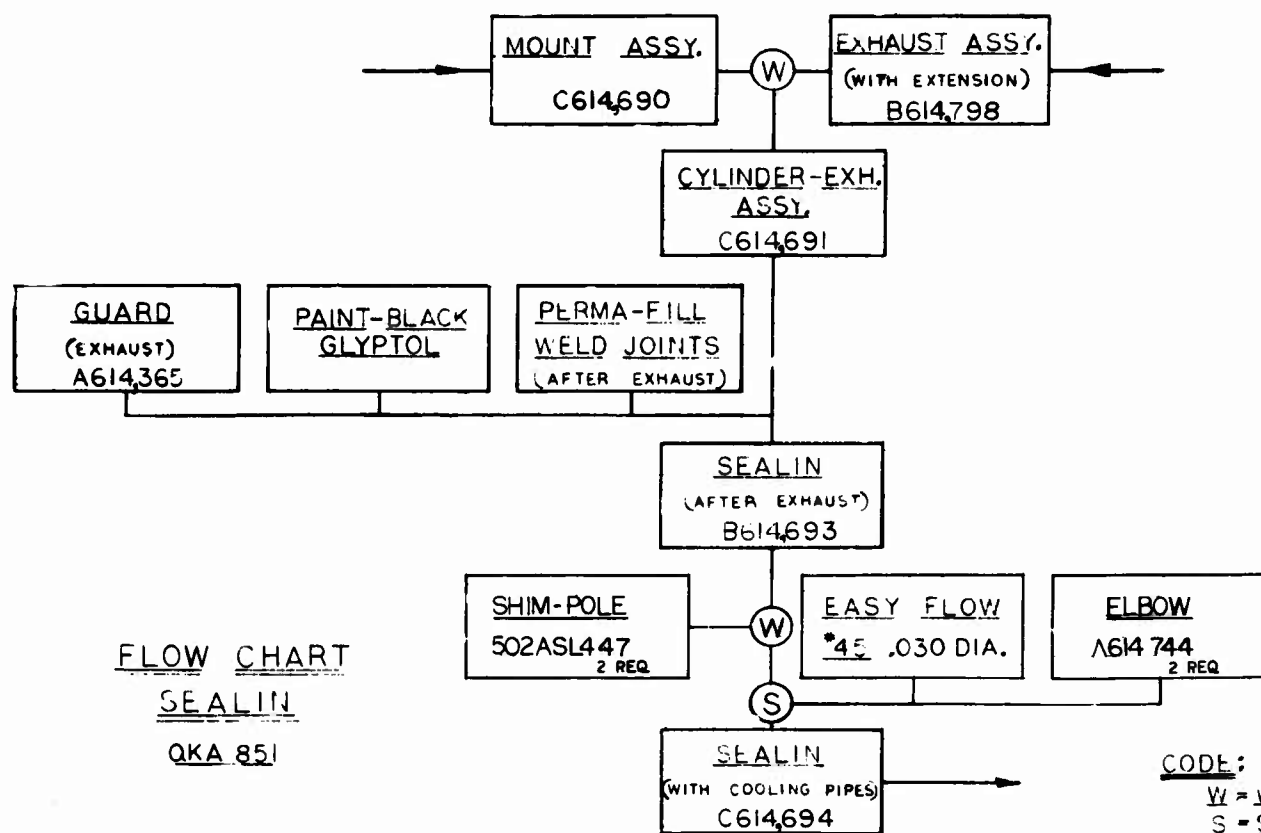

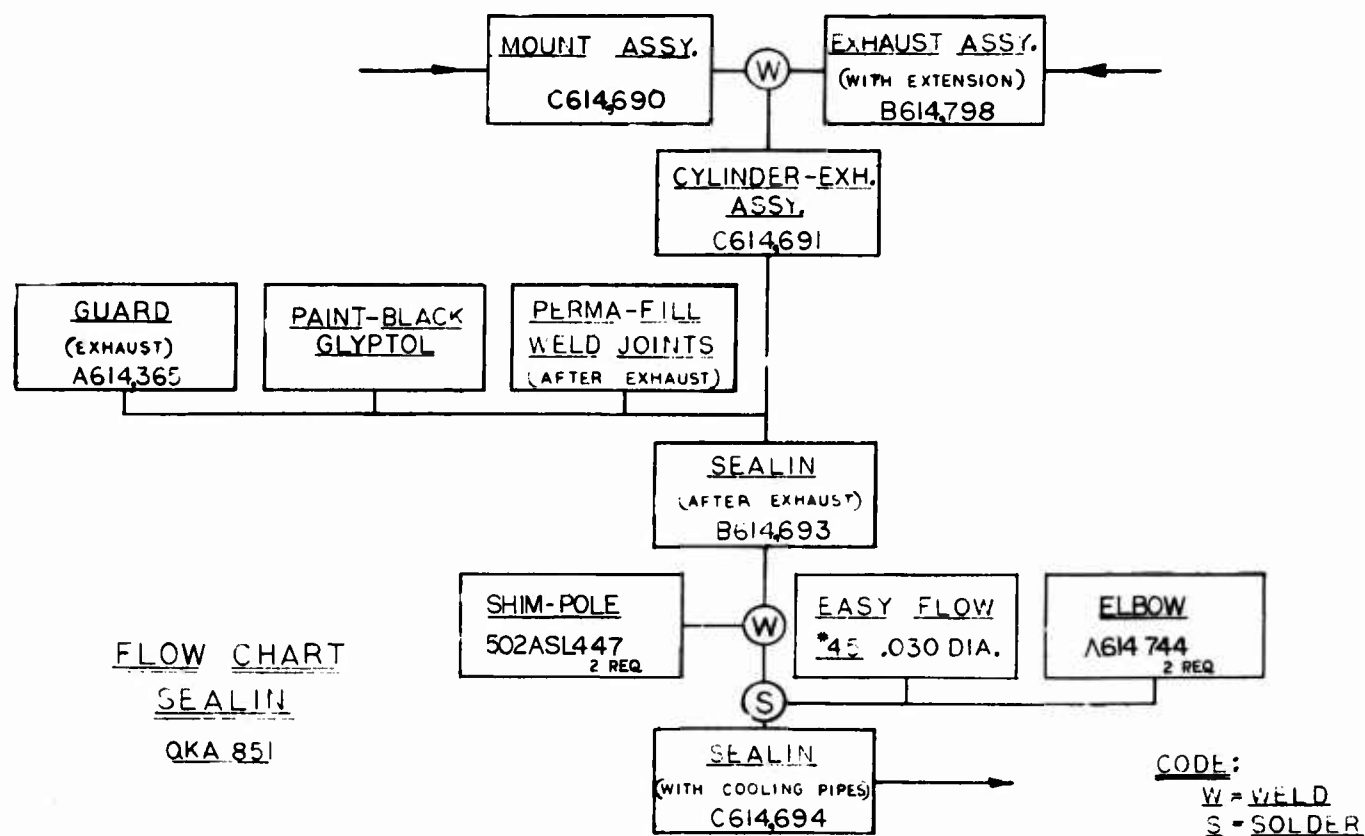

2

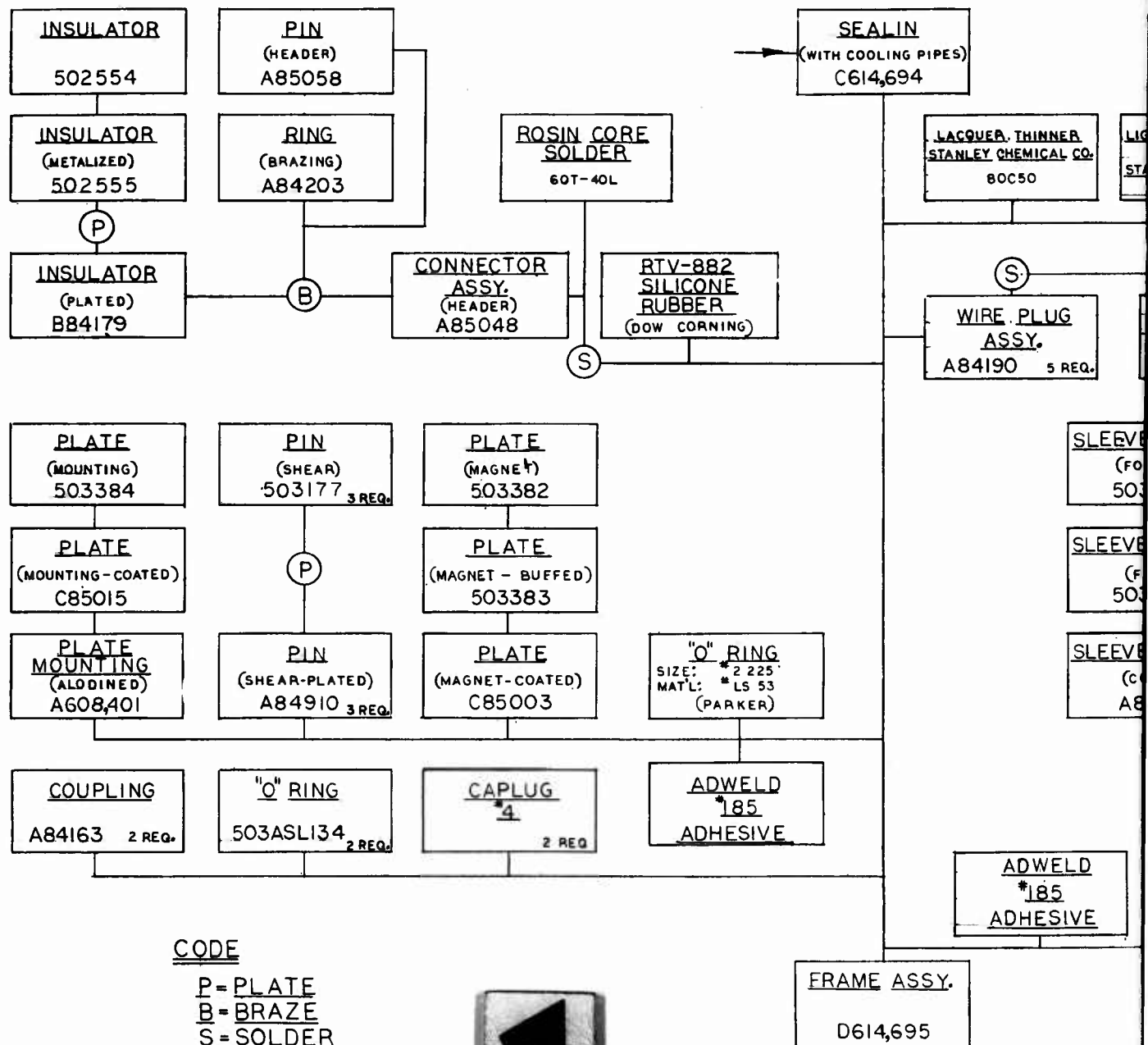

CODE

P = PLATE
 B = BRAZE
 S = SOLDER
 W = WELD



FLOW CHART
FRAME ASSEMBLY
QKA 851

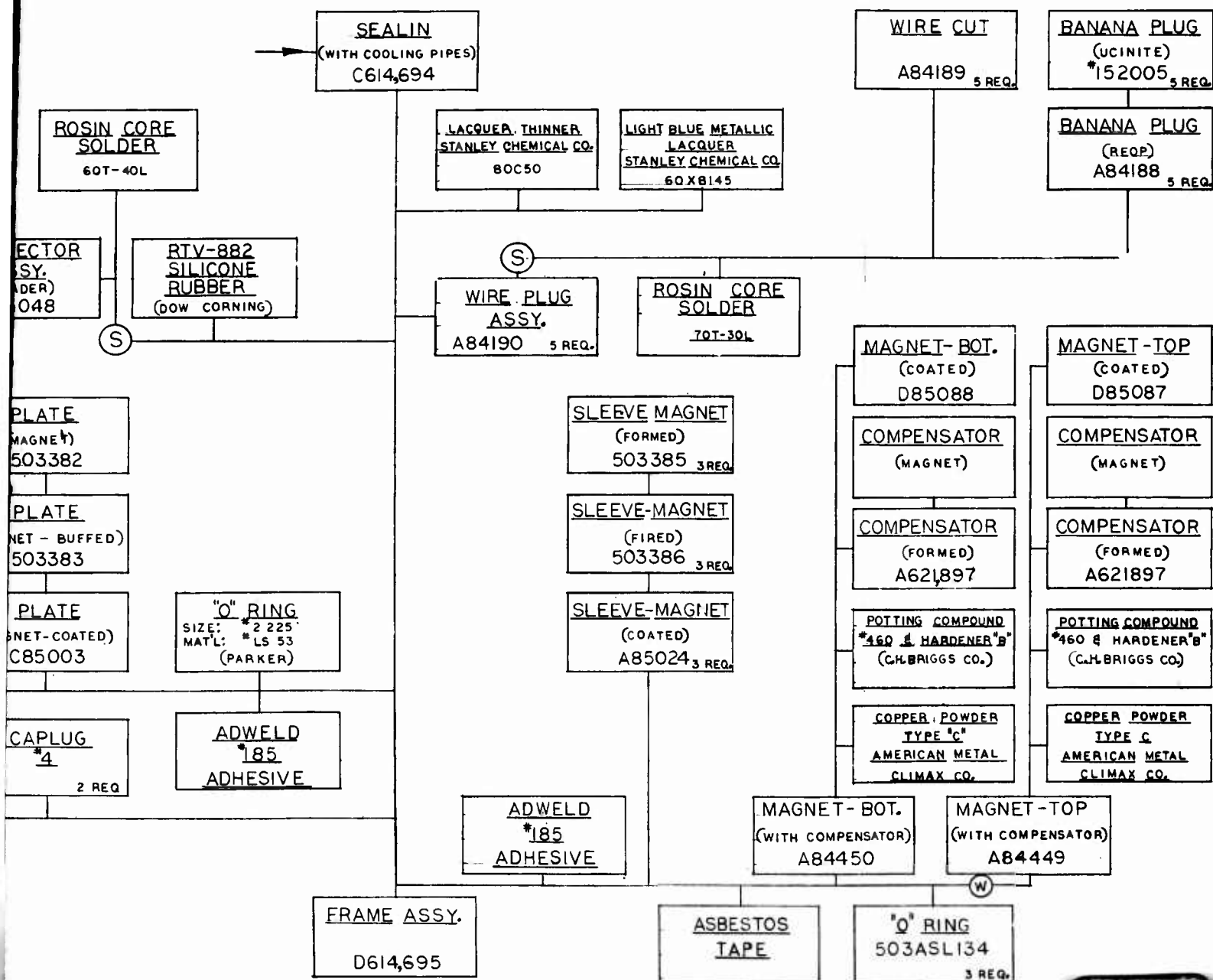

FLOW CHART
FRAME ASSEMBLY
QKA 851

2

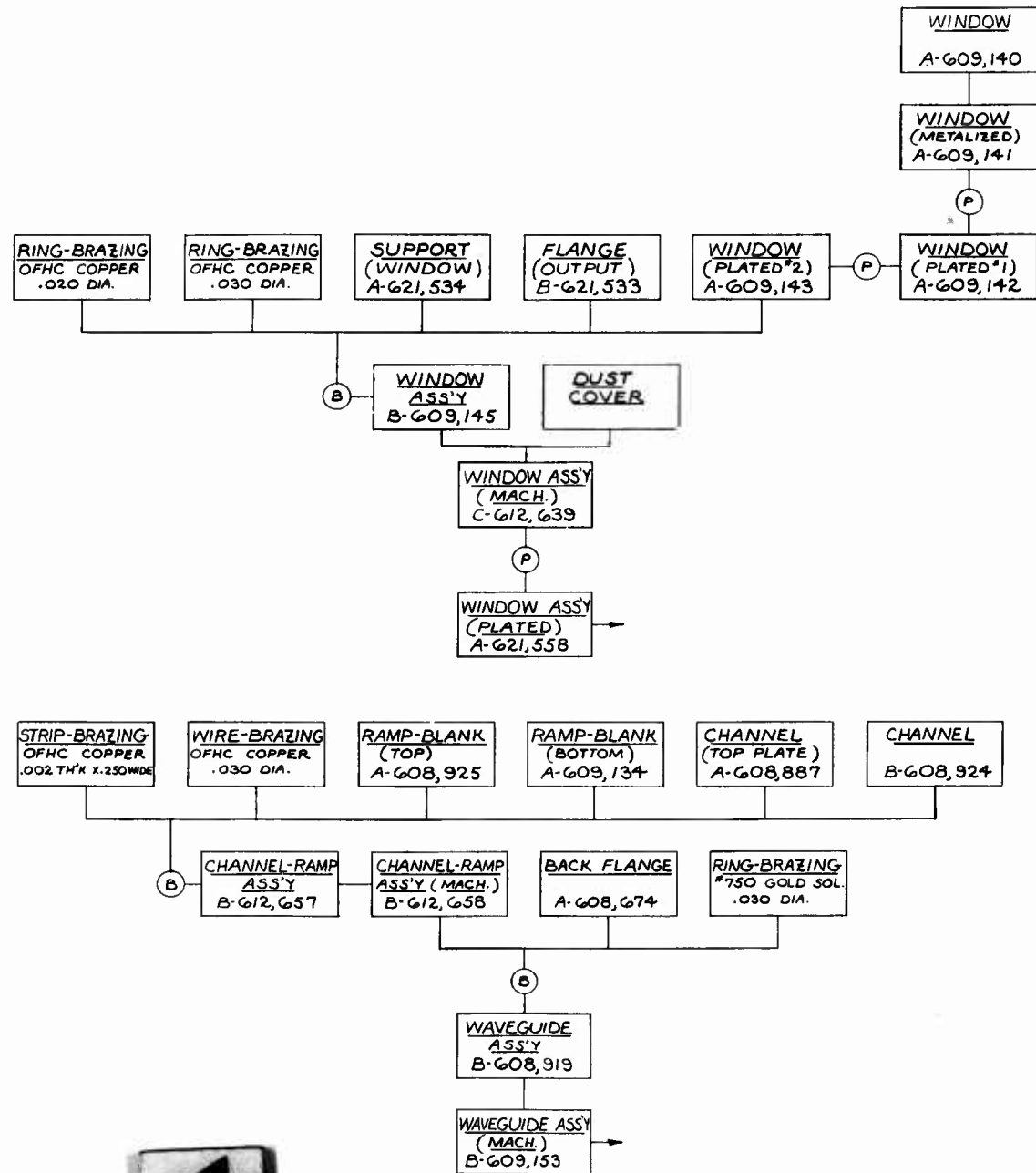

CODE:
B - BRAZE
P - PLATE



FLOW CHART
WAVEGUIDE ASS'Y (MACH.)
WINDOW ASS'Y (PLATED)
QR855

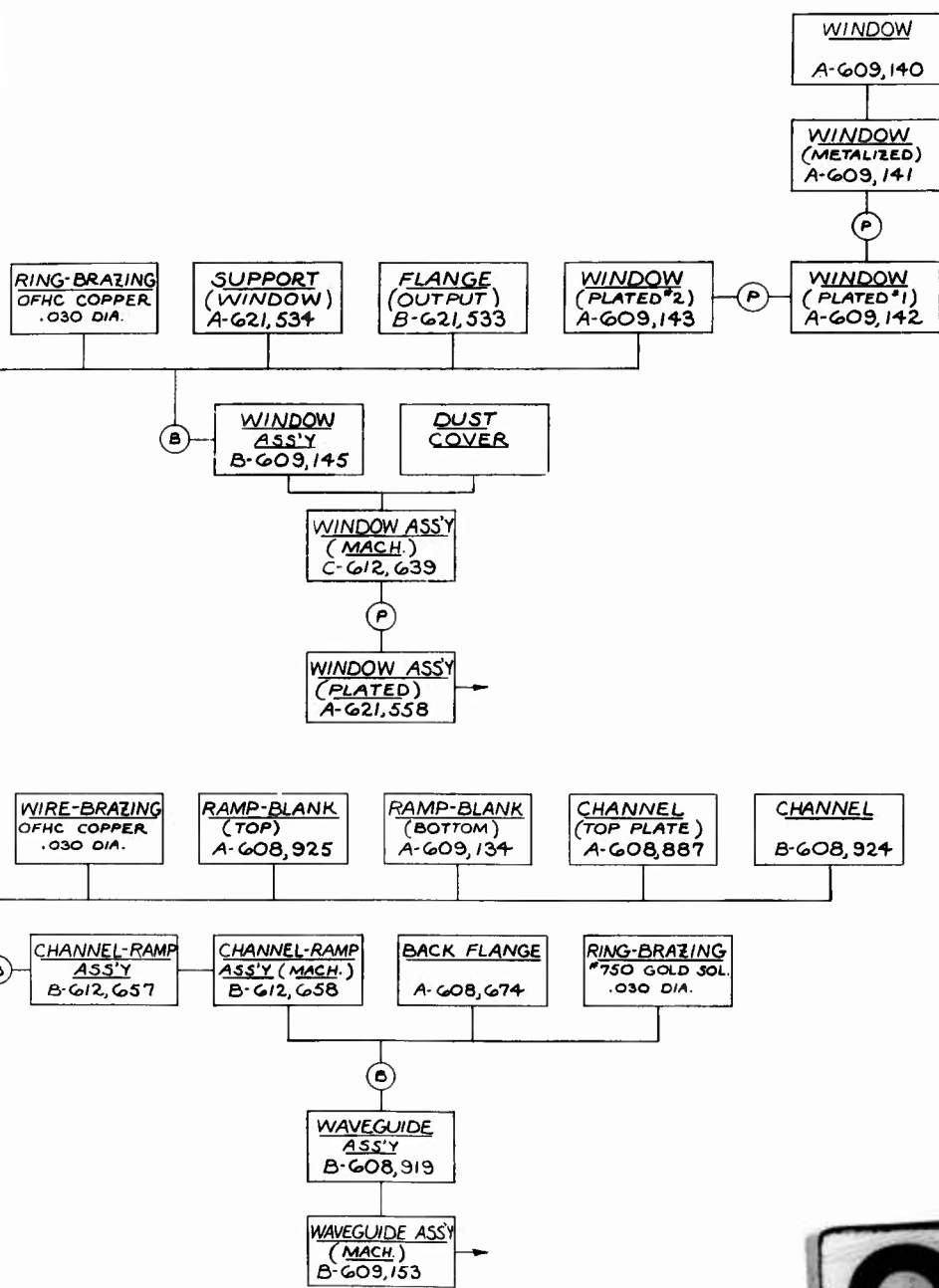

FLOW CHART
WAVEGUIDE ASSY (MACH.)
WINDOW ASSY (PLATED)
QKAB55



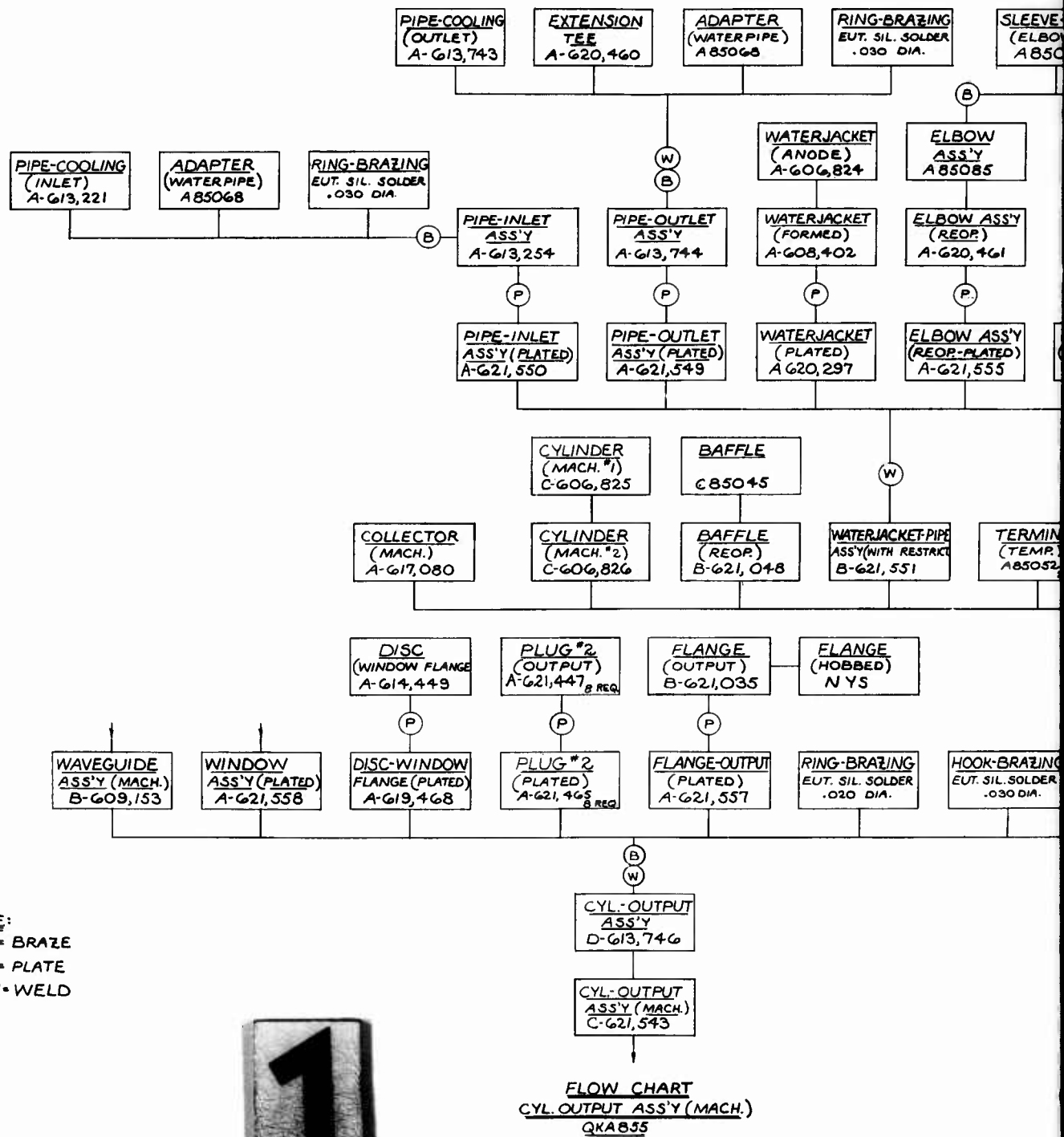

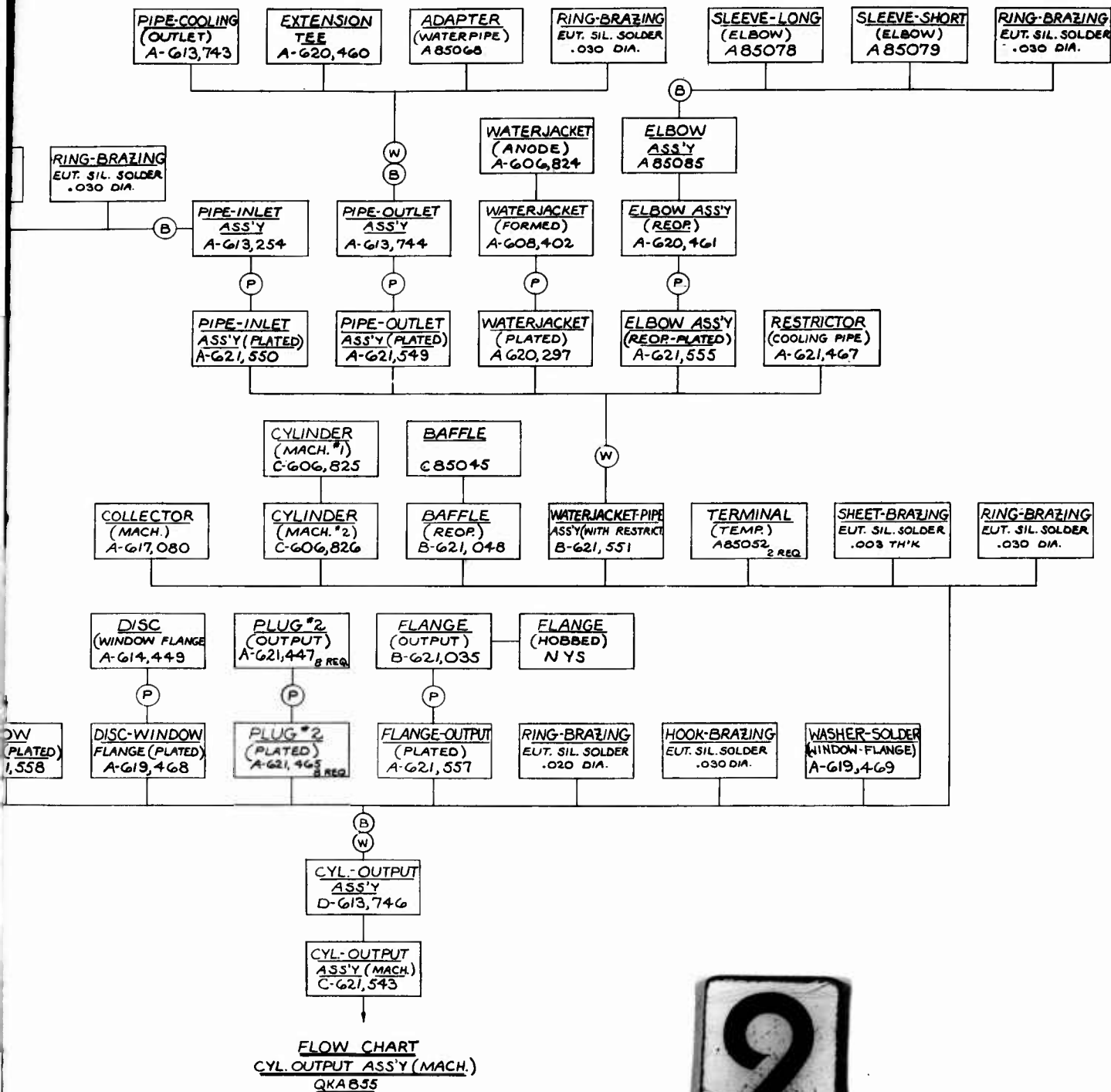

2

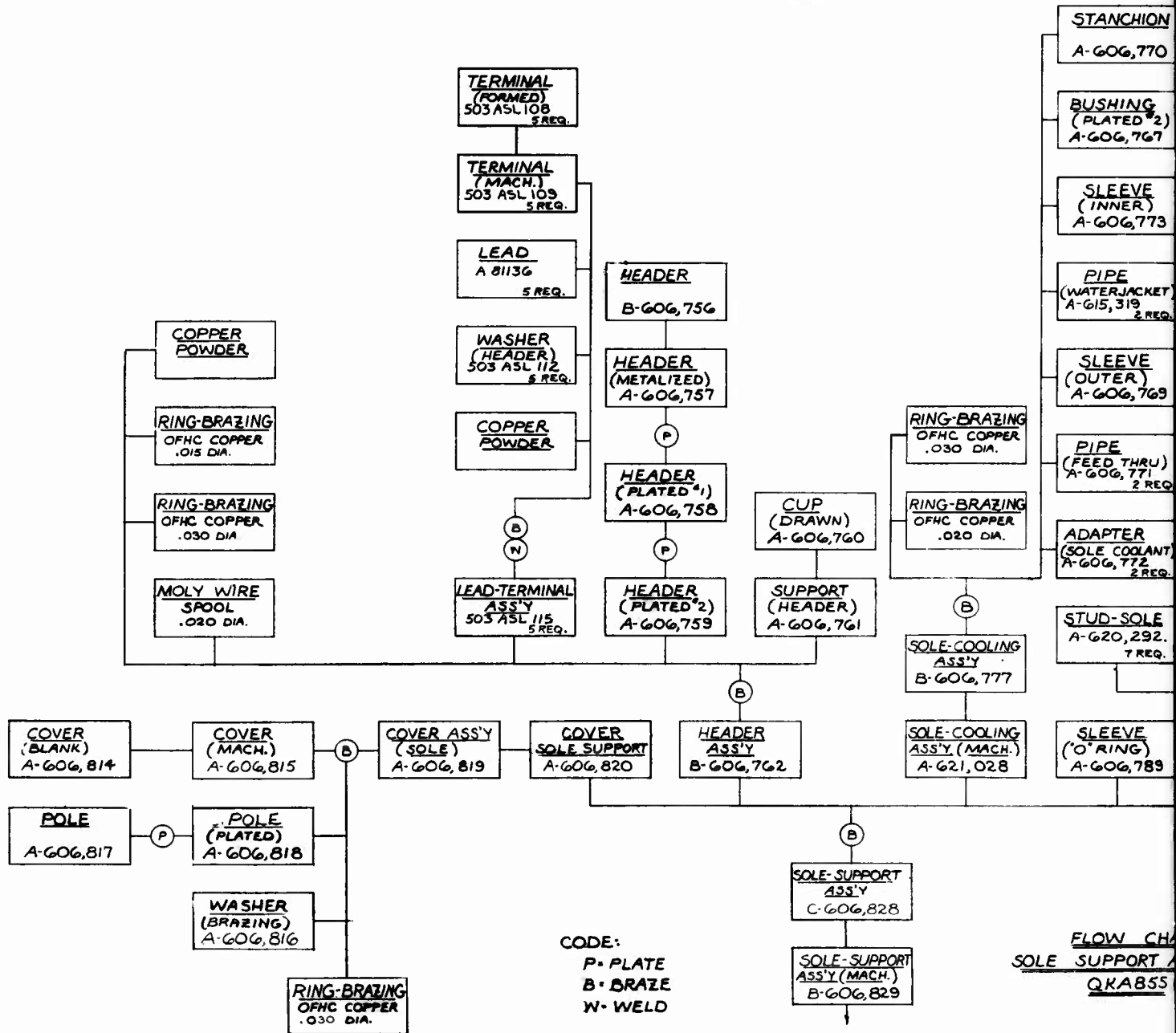

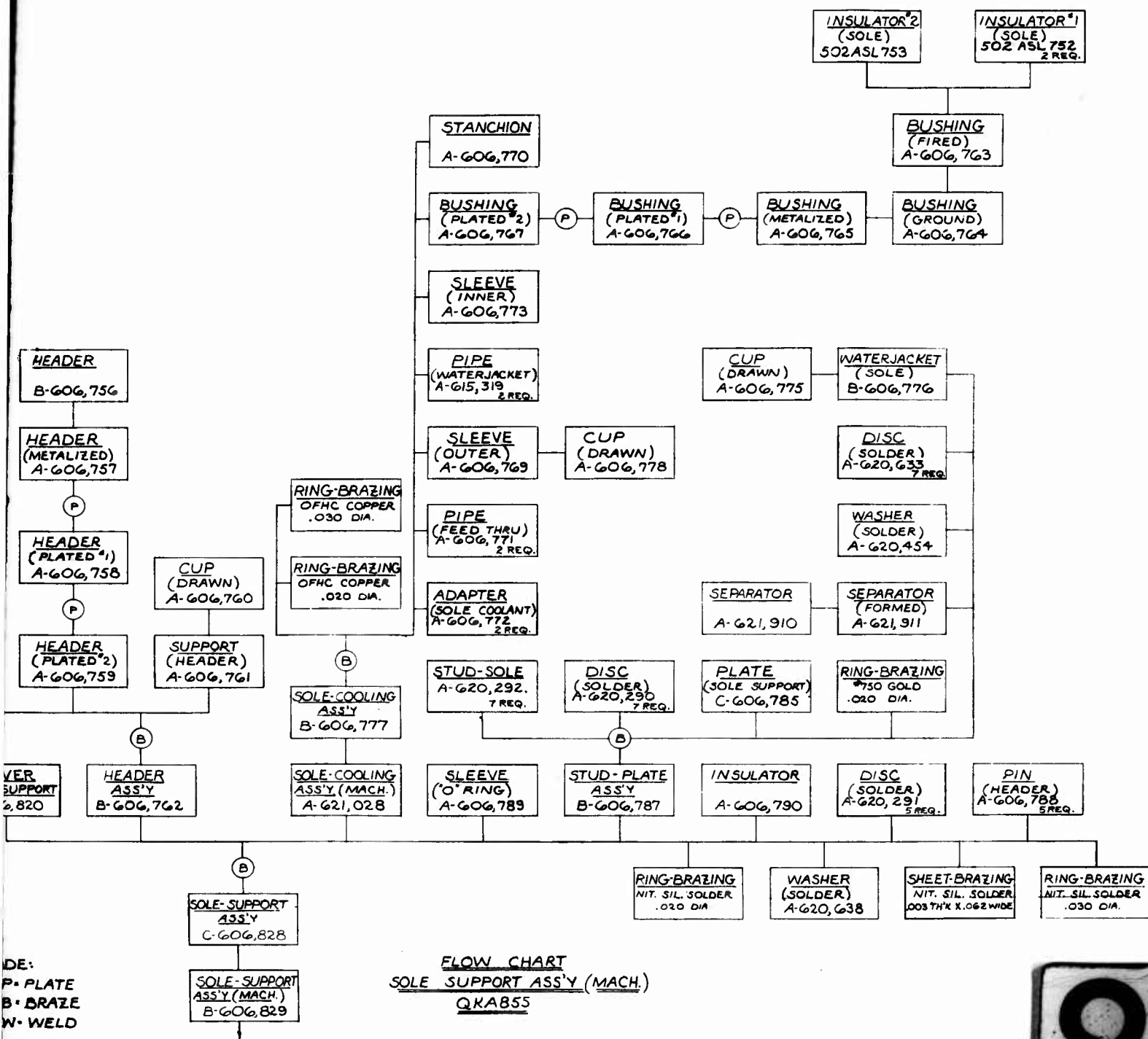

FLOW CHART
SOLE-SUPPORT ASS'Y (MACH.)
QKAB55

DE:
P- PLATE
B- BRAZE
W- WELD



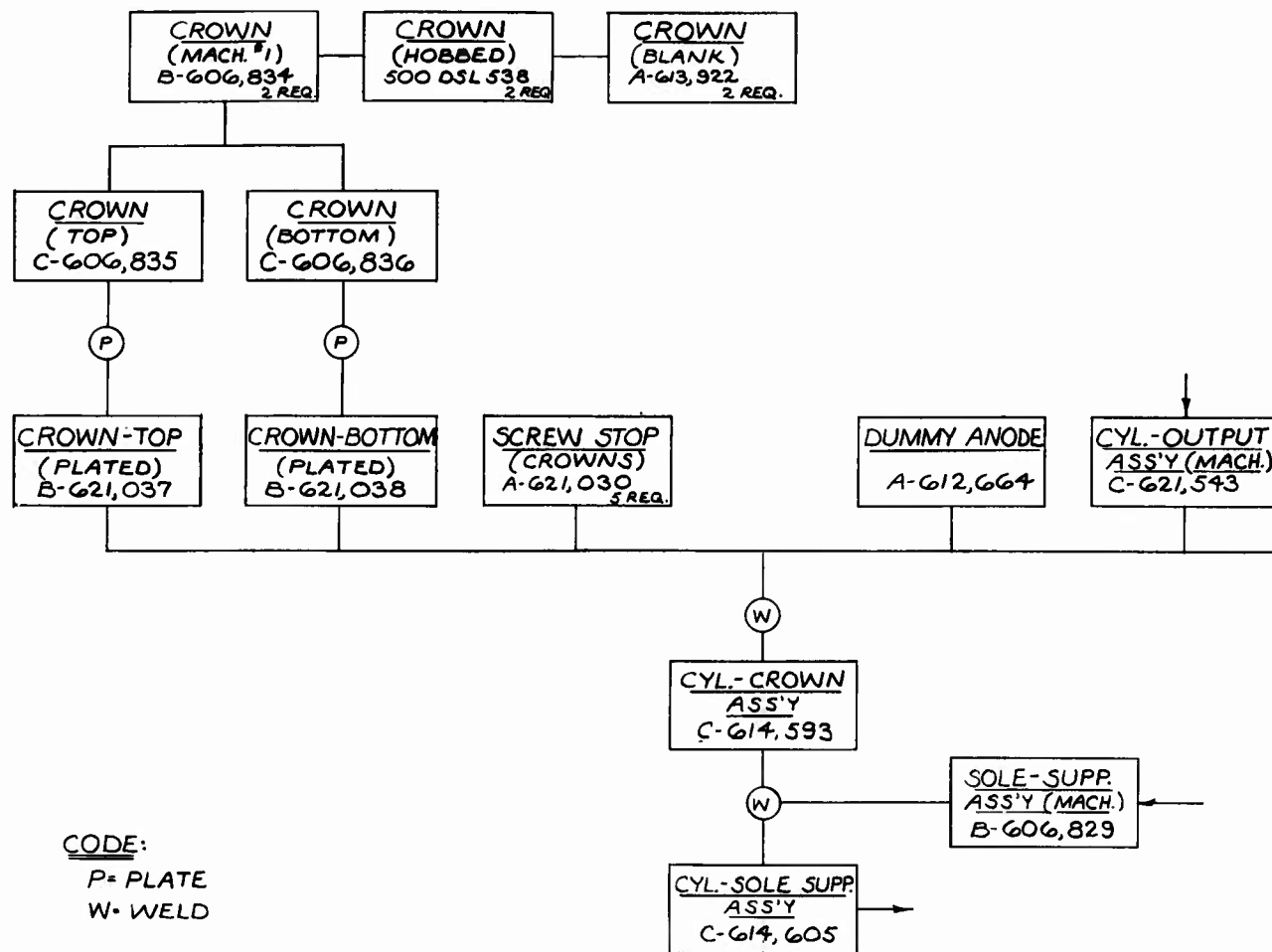

FLOW CHART
 CYL. SOLE SUPPORT ASS'Y
 QKAB55



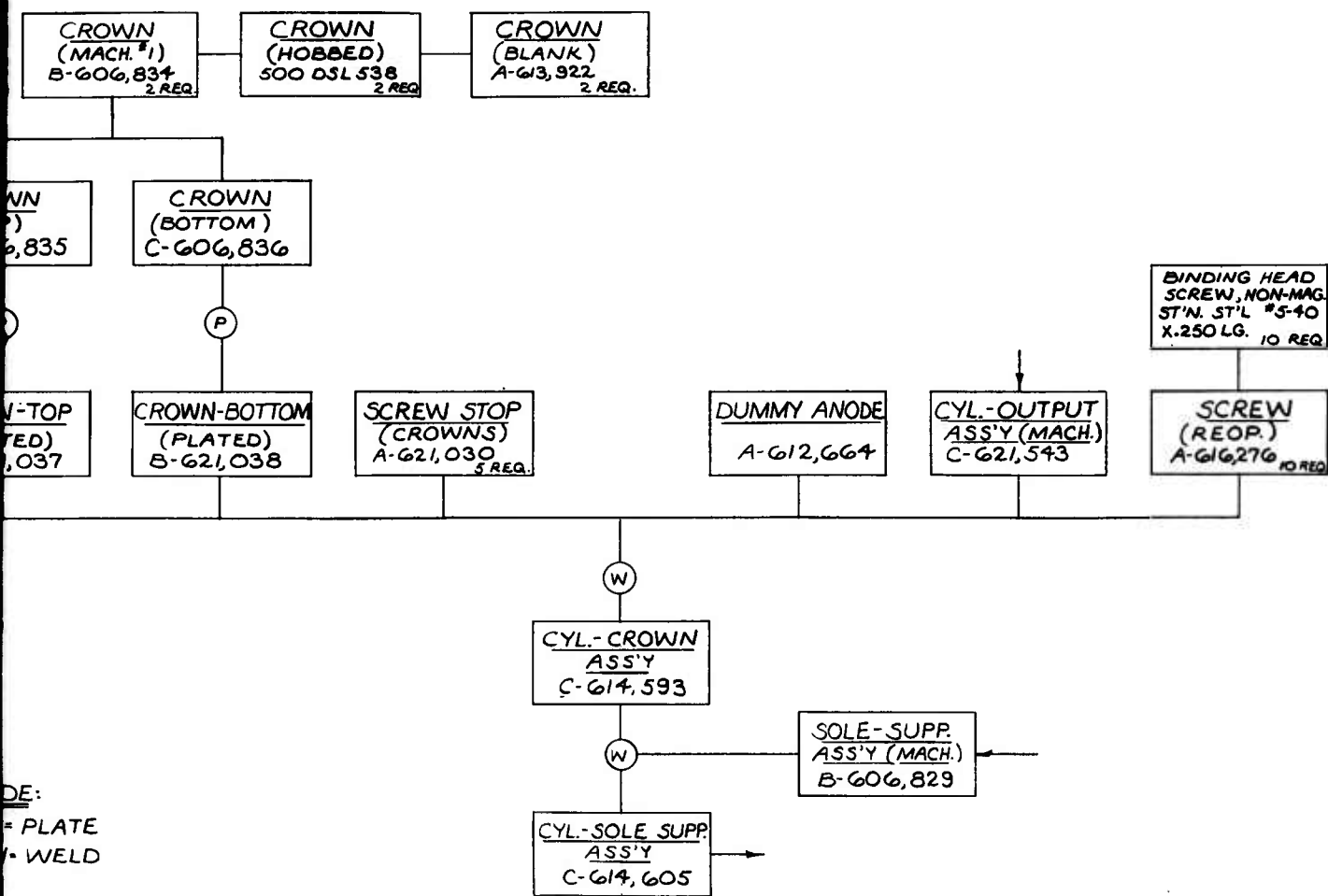

DE:
= PLATE
= WELD

FLOW CHART
CYL. SOLE SUPPORT ASS'Y
QKAB55

2

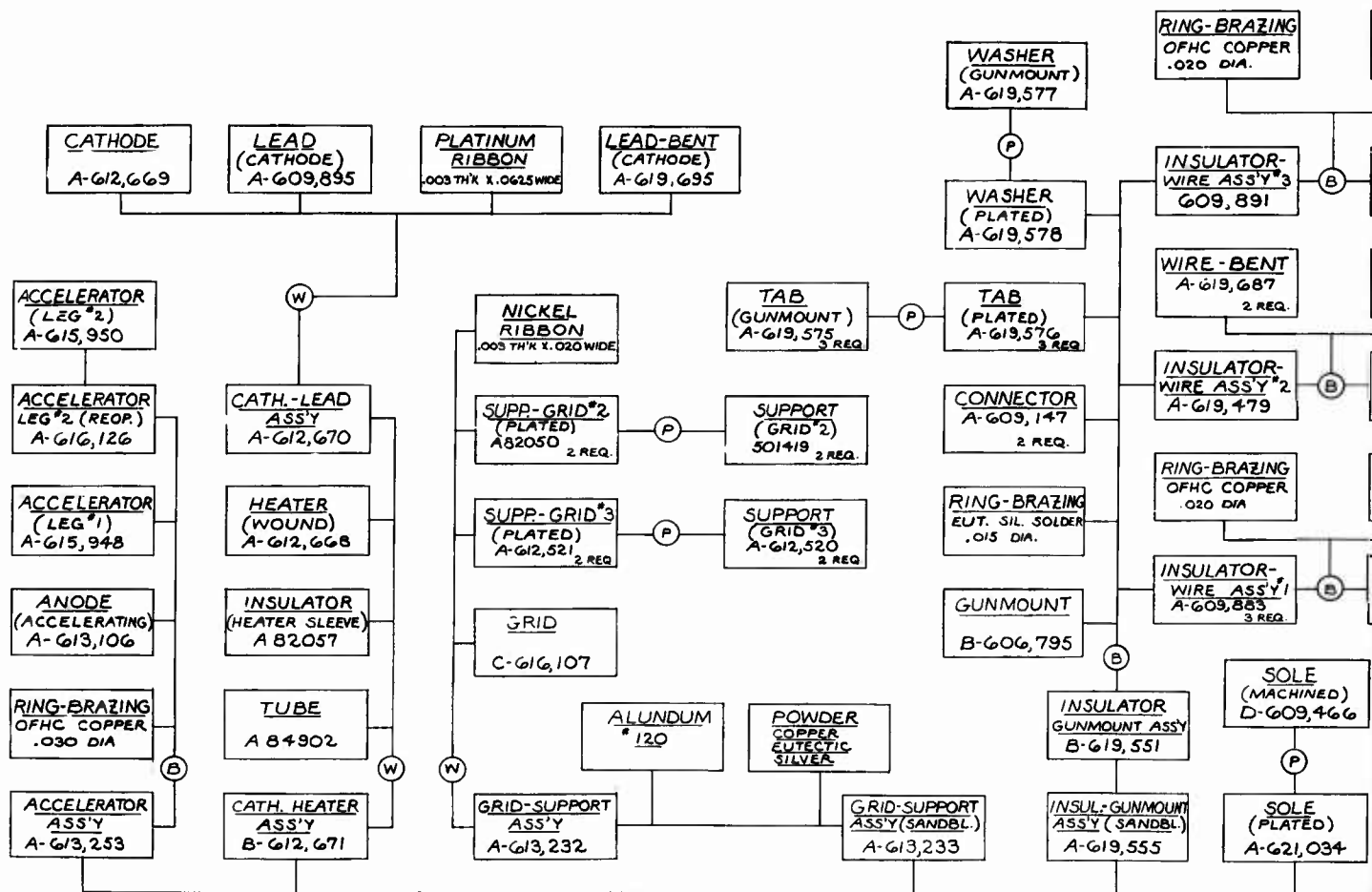

CODE:

B= BRAZE
P= PLATE
W= WELD



SOLE-GUN
ASS'Y
D-613,287

FLOW CHART
SOLE-GUN ASS'Y
QKA 855

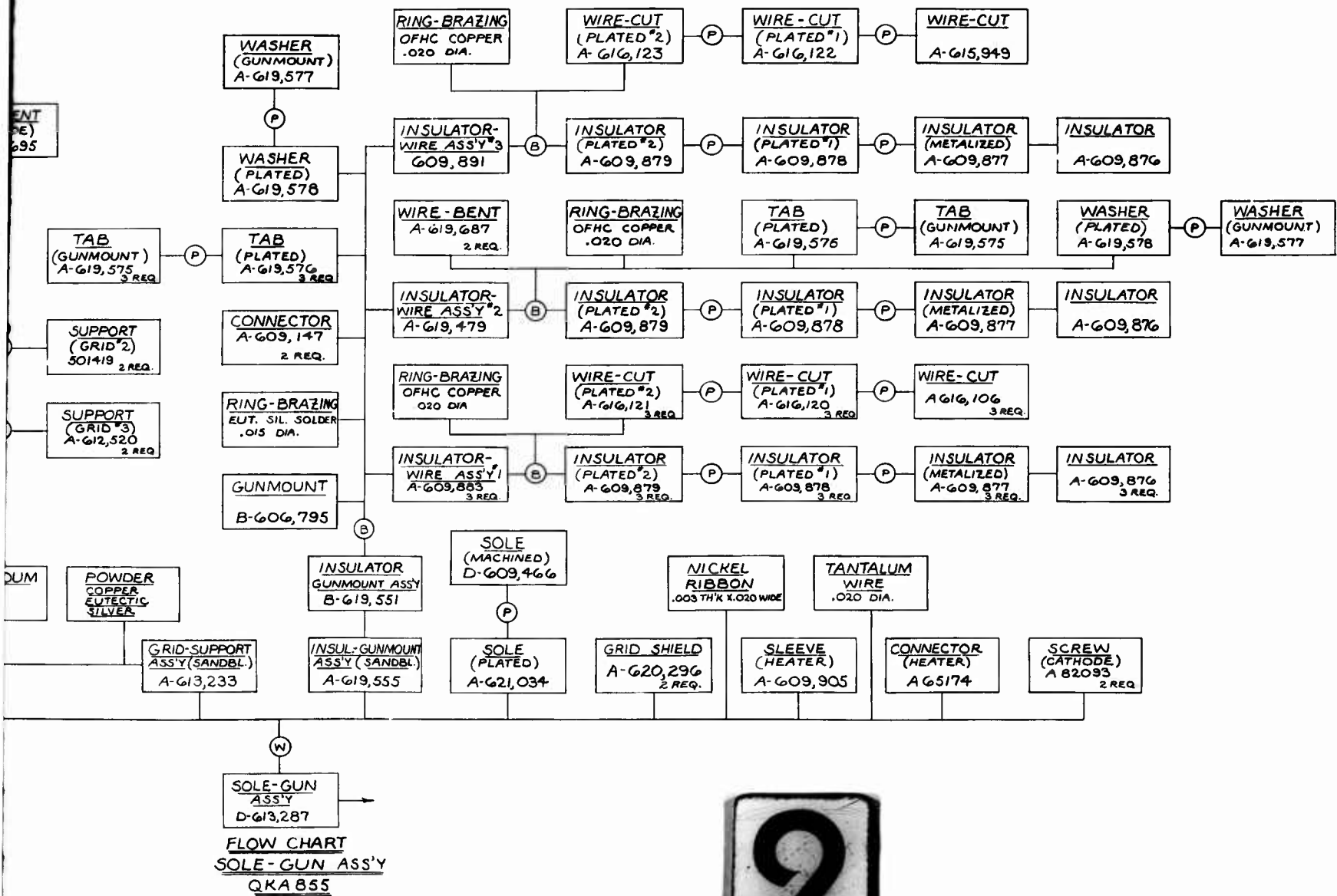

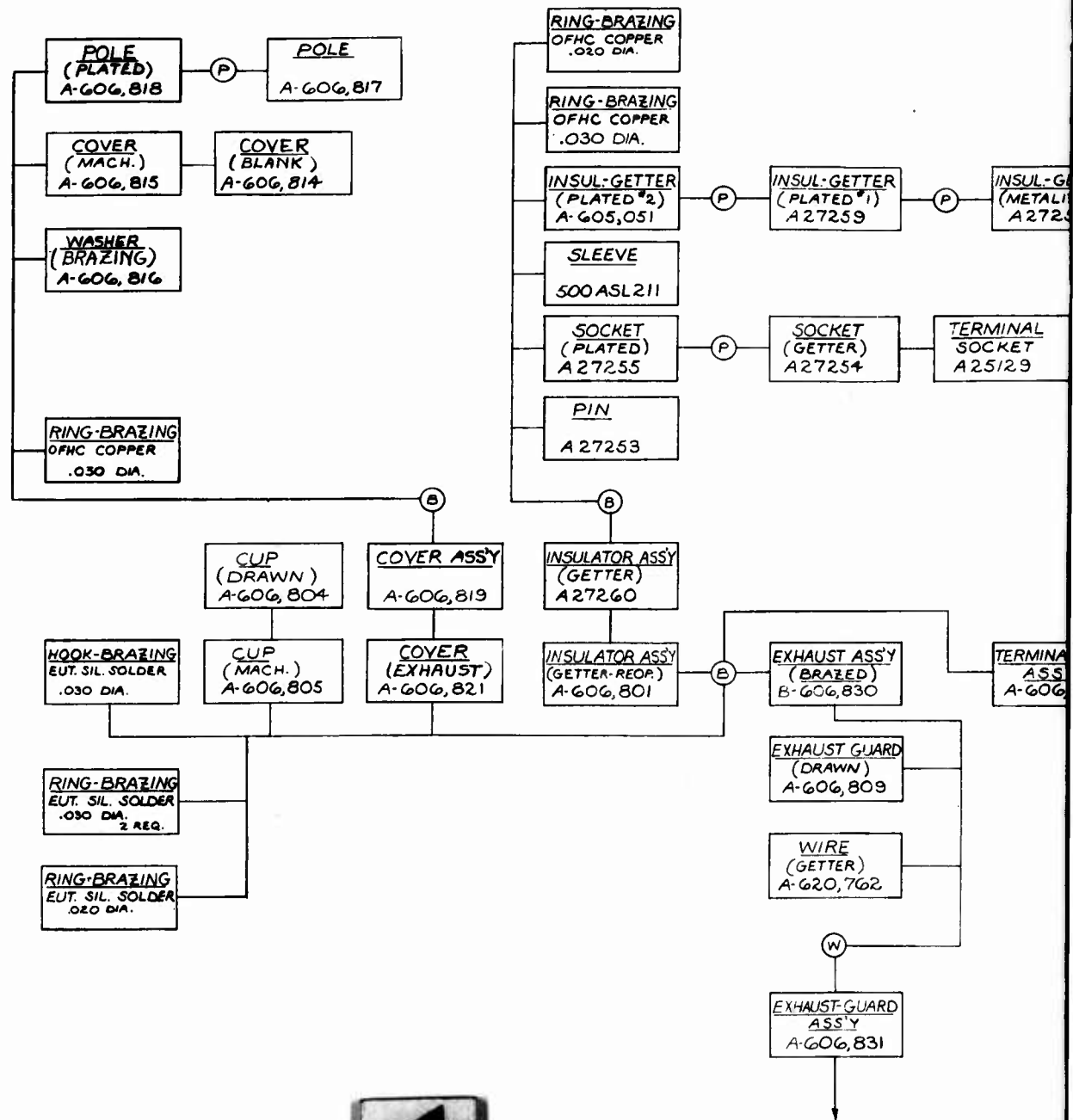

CODE:

B • BRAZE
W • WELD
P • PLATE



FLOW CHART
EXHAUST-GUARD ASS'Y
QKA855

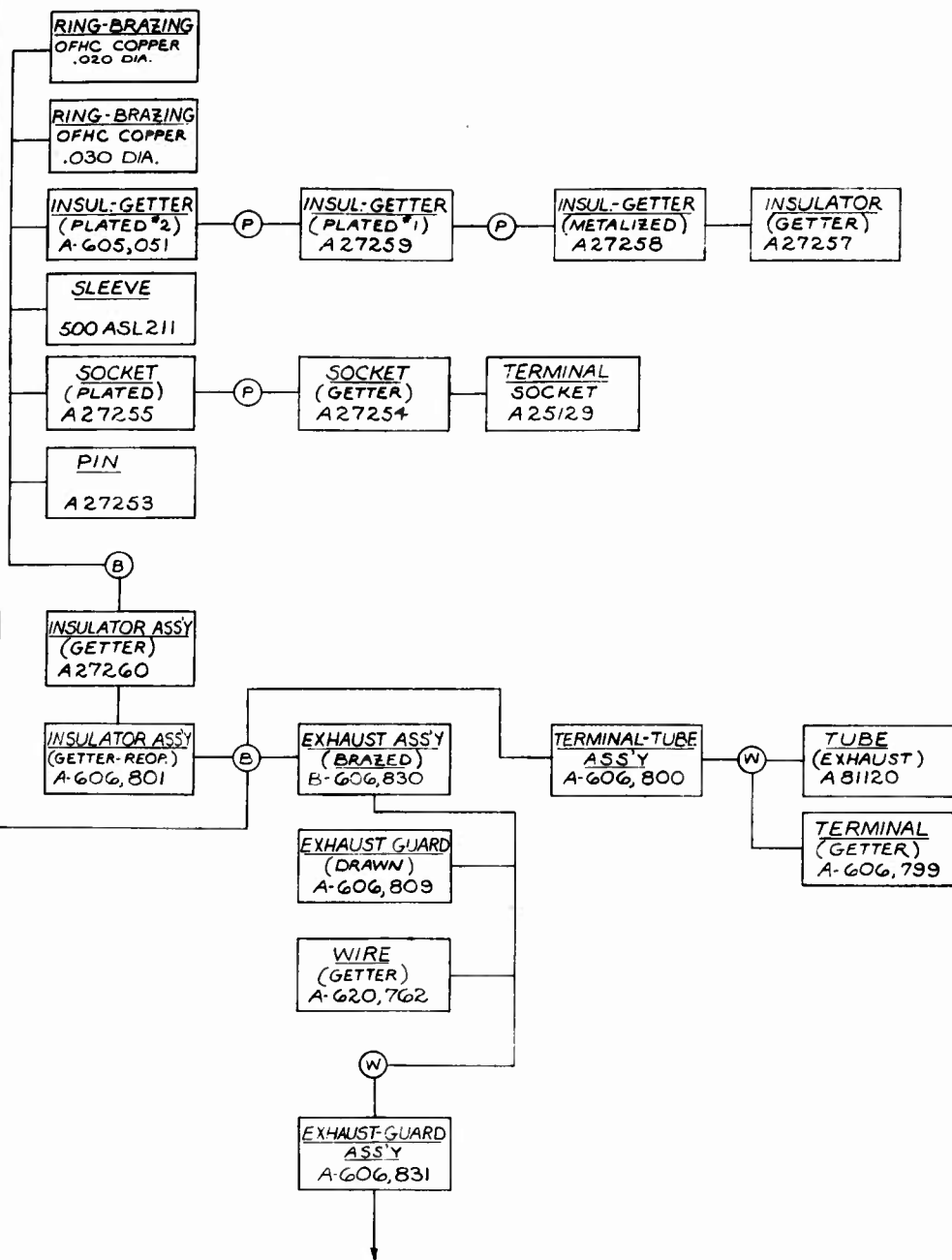

FLOW CHART
EXHAUST-GUARD ASS'Y
QKA855



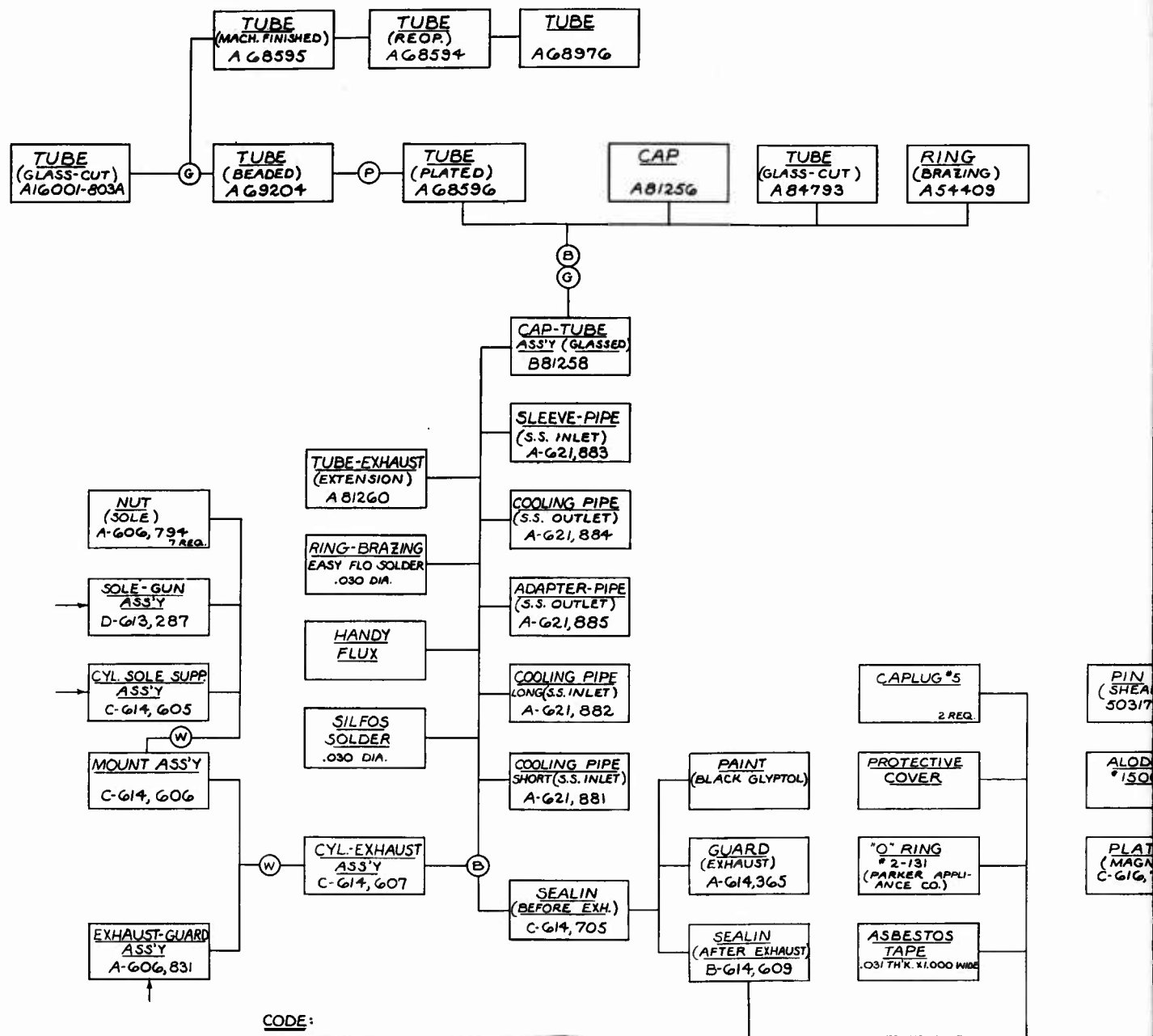

CODE:
 B= BRAZE
 P= PLATE
 G= GLASS
 W= WELD



FLOW CHART
 FINAL ASS'Y
 QK855

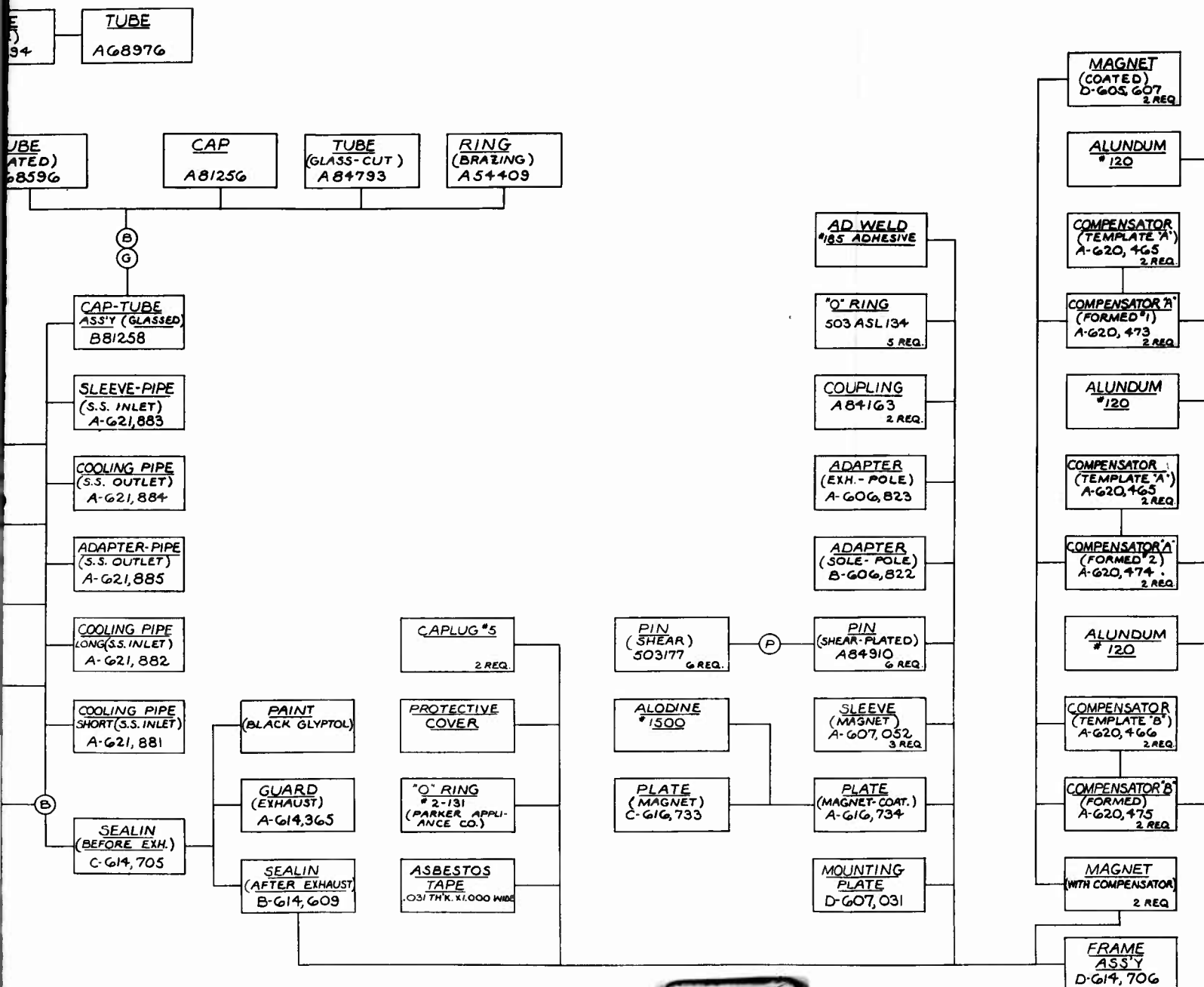

FLOW CHART
FINAL ASS'Y
QK855

2

APPENDIX III

DISTRIBUTION LIST

DISTRIBUTION LIST

<u>ADDRESSEE</u>	<u>QUANTITY</u>
Bell Telephone Laboratory, Inc. ATTN: H. M. Olson, Dept. 2843 Marion and Vine Streets Laureldale, Pennsylvania	1
Eitel-McCullough, Incorporated ATTN: Library 301 Industrial Way San Carlos, California	1
Hughes Aircraft Company Microwave Tube Division 11105 La Cienega Los Angeles 45, California	1
Radio Corporation of America Microwave Tube Operations 415 S. 5th Street Harrison, New Jersey	1
Raytheon Company Microwave and Power Tube Division Spencer Laboratory Wayside Avenue Burlington, Massachusetts	1
Sperry Electronic Tube Division Gainesville, Florida	1
Sylvania Electric Products, Incorporated Microwave Device Operations ATTN: Library 500 Evelyn Avenue Mountain View, California	1
IT and T Federal Laboratory 500 Washington Avenue Nutley, New Jersey	1
Litton Industries Electron Tube Division ATTN: Library 960 Industrial Way San Carlos, California	1

<u>ADDRESSEE</u>	<u>QUANTITY</u>
Microwave Associates ATTN: Librarian Burlington, Massachusetts	1
Microwave Electronics Company 4061 Transport Street Palo Alto, California	1
Varian Associates Tube Division Sales Department 611 Hanson Way Palo Alto, California	1
Watkins-Johnson Company Technical Library 3333 Hillview Avenue Palo Alto, California	1
Western Electric Company 555 Union Boulevard Allentown, Pennsylvania	1
Westinghouse Electric Corporation Electronic Tube Division, Microwave Department P. O. Box 284 Elmira, New York	1
Bomac Laboratories, Inc. Beverly, Massachusetts	1
Ryan Aeronautical Company Lindbergh Field ATTN: Engineering Library San Diego 12, California	1
AF Materials Laboratory ATTN: MATE Wright-Patterson AFB, Ohio 45433	3
AF Materials Laboratory ATTN: MAG (Technical Director) Wright-Patterson AFB, Ohio 45433	1

<u>ADDRESSEE</u>	<u>QUANTITY</u>
AF Materials Laboratory ATTN: MAA (Technical Director) Wright-Patterson AFB, Ohio 45433	1
Aeronautical Systems Division ATTN: ASRCEM-1A (Librarian) Wright-Patterson AFB, Ohio 45433	2
Headquarters, USAF ATTN: AFMPP-EQ, Room 4D-287 Lt Col Lee Manbeck Washington 25, D. C.	1
Headquarters, USAF ATTN: AFMPP-PD - Room 4C-283 Mr. J. E. Joers Washington 25, D. C.	1
Hqs. Air Force Systems Command ATTN: SCSNR - Mr. F. M. Wenger Andrews Air Force Base Washington 25, D. C.	1
Aeronautical Systems Division ATTN: ASRNET - Mr. A. H. Dicke Wright-Patterson AFB, Ohio 45433	1
Advisory Group on Electron Tubes ATTN: Col. H. W. Serig 346 Broadway New York, New York	1
Office, Director Defense Research and Engineering Office, Communications and Electronics ATTN: Lt Col C. G. Henline, U. S. A. (Ret) Rm 3D 1037, The Pentagon Washington 25, D. C.	1
Hqs, Air Force Systems Command ATTN: SCRC - Capt. C. Zimmerman Andrews AFB, Maryland	1
ESD (SRRI - Major J. W. Horne) L. G. Hanscom Field Bedford, Massachusetts	1

<u>ADDRESSEE</u>	<u>QUANTITY</u>
Aeronautical Systems Command ATTN: ASNPVE-2 - Mr. J. R. Hayes Wright-Patterson AFB, Ohio 45433	1
Headquarters, USAF ATTN: AFRDR-1N, Room 4D329 Lt Col C. C. Pinson Washington 25, D. C.	1
Aeronautical Systems Division ATTN: ASNSED - James H. C. Mulligan Wright-Patterson AFB, Ohio 45433	1
Commanding General U. S. Army Signal Supply Agency ATTN: ISG-SU-R2b Mr. Sokolove 225 South 18th Street Philadelphia, Pennsylvania	1
Commanding Officer U. S. Army Electronics Research and Development Lab ATTN: SELRA/PR Fort Monmouth, New Jersey	1
Chief, Bureau of Ships Department of the Navy ATTN: Code 691 AID Washington 25, D. C.	1
Chief, Bureau of Naval Weapons Department of the Navy ATTN: Code RAAV-333 Washington 25, D. C.	1
Chief, Office of Naval Research Naval Research Laboratory Department of the Navy ATTN: Code 5437 Washington 25, D. C.	1
Commander Electronics Supply Office Department of the Navy ATTN: Code 61 - Mr. J. J. Gray Great Lakes, Illinois	1
U. S. Naval Air Development Center ATTN: Mr. Robert Smith Johnsville, Pennsylvania	1

ADDRESSEEQUANTITY

Defense Documentation Center (DDC) Cameron Station ATTN: Document Service Center (TISIA-2) Alexandria, Virginia 22314	30
AF Materials Laboratory ATTN: MAA - Mr. J. Teres Wright-Patterson AFB, Ohio 45433	1
Aeronautical Systems Division ATTN: ASAPT Wright-Patterson AFB, Ohio 45433	1
AF Avionics Laboratory ATTN: AVT Wright-Patterson AFB, Ohio 45433	
Aeronautical Systems Division ATTN: ASAPRL - Tech Documentary Library Wright-Patterson AFB, Ohio 45433	1

<p>Electronics Branch Manufacturing Technology Division, Air Force Materials Laboratory, Research and Technology Division, Air Force Systems Command, Wright-Patterson Air Force Base, Ohio.</p> <p>FINAL REPORT ON ENGINEERING AND PRODUCTIZATION OF AN INTEGRATED FAMILY OF BACKWARD WAVE OSCILLATORS, Rpt. No. ASD TDR-7-695A, Vol. 2 of 2, Oct. 1963, 152 p. incl. illus. and tables.</p> <p>UNCLASSIFIED Report</p> <p>Appendix I - M.-BWO Design and Test Specifications.</p> <p>Appendix II - Family Process Specifications.</p> <p>Appendix III - Distribution List</p>	<p>UNCLASSIFIED</p> <ol style="list-style-type: none"> 1. Backward-Wave Oscillators (Family of) 2. Electronic Tube Devices I. Project 7-695A II. Contract No. III. Raytheon Company Spencer Laboratory Burlington, Mass. IV. Peter Janis V. James Gallagher In ASTIA Collection <p>UNCLASSIFIED</p>	<p>Electronics Branch Manufacturing Technology Division, Air Force Materials Laboratory, Research and Technology Division, Air Force Systems Command, Wright-Patterson Air Force Base, Ohio.</p> <p>FINAL REPORT ON ENGINEERING AND PRODUCTIZATION OF AN INTEGRATED FAMILY OF BACKWARD WAVE OSCILLATORS, Rpt. No. ASD TDR-7-695A, Vol. 2 of 2, Oct. 1963, 152 p. incl. illus. and tables.</p> <p>UNCLASSIFIED Report</p> <p>Appendix I - M.-BWO Design and Test Specifications.</p> <p>Appendix II - Family Process Specifications.</p> <p>Appendix III - Distribution List</p>	<p>UNCLASSIFIED</p> <ol style="list-style-type: none"> 1. Backward-Wave Oscillators (Family of) 2. Electronic Tube Devices I. Project 7-695A II. Contract No. III. Raytheon Company Spencer Laboratory Burlington, Mass. IV. Peter Janis V. James Gallagher In ASTIA Collection <p>UNCLASSIFIED</p>
<p>Electronics Branch Manufacturing Technology Division, Air Force Materials Laboratory, Research and Technology Division, Air Force Systems Command, Wright-Patterson Air Force Base, Ohio.</p> <p>FINAL REPORT ON ENGINEERING AND PRODUCTIZATION OF AN INTEGRATED FAMILY OF BACKWARD WAVE OSCILLATORS, Rpt. No. ASD TDR-7-695A, Vol. 2 of 2, Oct. 1963, 152 p. incl. illus. and tables.</p> <p>UNCLASSIFIED Report</p> <p>Appendix I - M.-BWO Design and Test Specifications.</p> <p>Appendix II - Family Process Specifications.</p> <p>Appendix III - Distribution List</p>	<p>UNCLASSIFIED</p> <ol style="list-style-type: none"> 1. Backward-Wave Oscillators (Family of) 2. Electronic Tube Devices I. Project 7-695A II. Contract No. III. Raytheon Company Spencer Laboratory Burlington, Mass. IV. Peter Janis V. James Gallagher In ASTIA Collection <p>UNCLASSIFIED</p>	<p>Electronics Branch Manufacturing Technology Division, Air Force Materials Laboratory, Research and Technology Division, Air Force Systems Command, Wright-Patterson Air Force Base, Ohio.</p> <p>FINAL REPORT ON ENGINEERING AND PRODUCTIZATION OF AN INTEGRATED FAMILY OF BACKWARD WAVE OSCILLATORS, Rpt. No. ASD TDR-7-695A, Vol. 2 of 2, Oct. 1963, 152 p. incl. illus. and tables.</p> <p>UNCLASSIFIED Report</p> <p>Appendix I - M.-BWO Design and Test Specifications.</p> <p>Appendix II - Family Process Specifications.</p> <p>Appendix III - Distribution List</p>	<p>UNCLASSIFIED</p> <ol style="list-style-type: none"> 1. Backward-Wave Oscillators (Family of) 2. Electronic Tube Devices I. Project 7-695A II. Contract No. III. Raytheon Company Spencer Laboratory Burlington, Mass. IV. Peter Janis V. James Gallagher In ASTIA Collection <p>UNCLASSIFIED</p>

<p>Electronics Branch Manufacturing Technology Division, Air Force Materials Laboratory, Research and Technology Division, Air Force Systems Command, Wright-Patterson Air Force Base, Ohio.</p> <p>FINAL REPORT ON ENGINEERING AND PRODUCTIZATION OF AN INTEGRATED FAMILY OF BACKWARD WAVE OSCILLATORS, Rpt. No. ASD TDR-7-695A, Vol. 2 of 2, Oct. 1963, 152 p. incl. illus. and tables.</p> <p>UNCLASSIFIED Report</p> <p>Appendix I - M-BWO Design and Test Specifications.</p> <p>Appendix II - Family Process Specifications.</p> <p>Appendix III - Distribution List</p>	<p>UNCLASSIFIED</p> <ol style="list-style-type: none"> 1. Backward-Wave Oscillators (Family of) 2. Electronic Tube Devices I. Project 7-695A II. Contract No. AF33(600)43395 III. Raytheon Company Spencer Laboratory Burlington, Mass. IV. Peter Janis V. James Gallagher In ASTIA Collection <p>UNCLASSIFIED</p>	<p>Electronics Branch Manufacturing Technology Division, Air Force Materials Laboratory, Research and Technology Division, Air Force Systems Command, Wright-Patterson Air Force Base, Ohio.</p> <p>FINAL REPORT ON ENGINEERING AND PRODUCTIZATION OF AN INTEGRATED FAMILY OF BACKWARD WAVE OSCILLATORS, Rpt. No. ASD TDR-7-695A, Vol. 2 of 2, Oct. 1963, 152 p. incl. illus. and tables.</p> <p>UNCLASSIFIED Report</p> <p>Appendix I - M-BWO Design and Test Specifications.</p> <p>Appendix II - Family Process Specifications.</p> <p>Appendix III - Distribution List</p>	<p>UNCLASSIFIED</p> <ol style="list-style-type: none"> 1. Backward-Wave Oscillators (Family of) 2. Electronic Tube Devices I. Project 7-695A II. Contract No. AF33(600)43395 III. Raytheon Company Spencer Laboratory Burlington, Mass. IV. Peter Janis V. James Gallagher In ASTIA Collection <p>UNCLASSIFIED</p>
<p>Electronics Branch Manufacturing Technology Division, Air Force Materials Laboratory, Research and Technology Division, Air Force Systems Command, Wright-Patterson Air Force Base, Ohio.</p> <p>FINAL REPORT ON ENGINEERING AND PRODUCTIZATION OF AN INTEGRATED FAMILY OF BACKWARD WAVE OSCILLATORS, Rpt. No. ASD TDR-7-695A, Vol. 2 of 2, Oct. 1963, 152 p. incl. illus. and tables.</p> <p>UNCLASSIFIED Report</p> <p>Appendix I - M-BWO Design and Test Specifications.</p> <p>Appendix II - Family Process Specifications.</p> <p>Appendix III - Distribution List</p>	<p>UNCLASSIFIED</p> <ol style="list-style-type: none"> 1. Backward-Wave Oscillators (Family of) 2. Electronic Tube Devices I. Project 7-695A II. Contract No. AF33(600)43395 III. Raytheon Company Spencer Laboratory Burlington, Mass. IV. Peter Janis V. James Gallagher In ASTIA Collection <p>UNCLASSIFIED</p>	<p>Electronics Branch Manufacturing Technology Division, Air Force Materials Laboratory, Research and Technology Division, Air Force Systems Command, Wright-Patterson Air Force Base, Ohio.</p> <p>FINAL REPORT ON ENGINEERING AND PRODUCTIZATION OF AN INTEGRATED FAMILY OF BACKWARD WAVE OSCILLATORS, Rpt. No. ASD TDR-7-695A, Vol. 2 of 2, Oct. 1963, 152 p. incl. illus. and tables.</p> <p>UNCLASSIFIED Report</p> <p>Appendix I - M-BWO Design and Test Specifications.</p> <p>Appendix II - Family Process Specifications.</p> <p>Appendix III - Distribution List</p>	<p>UNCLASSIFIED</p> <ol style="list-style-type: none"> 1. Backward-Wave Oscillators (Family of) 2. Electronic Tube Devices I. Project 7-695A II. Contract No. AF33(600)43395 III. Raytheon Company Spencer Laboratory Burlington, Mass. IV. Peter Janis V. James Gallagher In ASTIA Collection <p>UNCLASSIFIED</p>

UNCLASSIFIED

UNCLASSIFIED