

AD-431314

RTD-TDR-63-4015

20070917064

**A PROBE FOR THE INSTANTANEOUS
MEASUREMENT OF SURFACE TEMPERATURE**

TECHNICAL DOCUMENTARY REPORT No. RTD-TDR-63-4015

JANUARY 1964

AF FLIGHT DYNAMICS LABORATORY
RESEARCH AND TECHNOLOGY DIVISION
AIR FORCE SYSTEMS COMMAND
WRIGHT-PATTERSON AIR FORCE BASE, OHIO

Project No. 1347, Task No. 134702

(Prepared under Contract No. AF 33(657)-8745 by the
Cornell Aeronautical Laboratory, Inc., Buffalo, New York;
Gerald A. Sterbutzel, John R. Shoemaker, Robert C. MacArthur,
Henry M. Korytkowski, Franklin A. Vassallo, and
W. R. Brown, authors.)

NOTICES

When Government drawings, specifications, or other data are used for any purpose other than in connection with a definitely related Government procurement operation, the United States Government thereby incurs no responsibility nor any obligation whatsoever; and the fact that the Government may have formulated, furnished, or in any way supplied the said drawings, specifications, or other data, is not to be regarded by implication or otherwise as in any manner licensing the holder or any other person or corporation, or conveying any rights or permission to manufacture, use, or sell any patented invention that may in any way be related thereto.

Qualified requesters may obtain copies of this report from the Defense Documentation Center (DDC), (formerly ASTIA), Cameron Station, Bldg. 5, 5010 Duke Street, Alexandria 4, Virginia

This report has been released to the Office of Technical Services, U.S. Department of Commerce, Washington 25, D.C., in stock quantities for sale to the general public.

Copies of this report should not be returned to the Aeronautical Systems Division unless return is required by security considerations, contractual obligations, or notice on a specific document.

FOREWORD

This report was prepared by Cornell Aeronautical Laboratory, Inc., Buffalo, New York under USAF Contract No. AF-33(657)-8745. The program was monitored by Mr. W. E. Alexander, AF Flight Dynamics Laboratory, Research and Technology Division, Wright-Patterson Air Force Base, Ohio. The studies were started on June 11, 1962 and were completed on July 31, 1963.

At Cornell Aeronautical Laboratory, Inc., Gerald A. Sterbutzel was the project leader. John R. Shoemaker conducted the experimental tests and made significant contributions in probe sensor design and fabrication techniques. Robert C. MacArthur and Henry M. Korytkowski designed and developed the electronic part of the system. Franklin A. Vassallo performed the necessary analytical work and W. R. Brown was consulted in the materials field.

ABSTRACT

This report describes the design, development and evaluation of a probe system with which instantaneous temperatures can be measured on a variety of surfaces heated by radiation. It discusses a 1000°F system, its methods of operation and its performance characteristics. It shows that the 1000°F probe operates on a variety of materials with an accuracy generally better than 3/8 percent and with a time constant of the order of 0.1 seconds. A comparison of the performance of permanent surface thermocouple installations using iron-constantan, chromel-constantan and chromel-alumel thermocouples, various thermocouple wire sizes, orientations, rates of heating and surface materials was made with the 1000°F probe performance. In almost every case, the accuracy of the probe was better than the accuracy of permanent surface thermocouple installation. The design of a probe system believed to be feasible for extending the range of operation to 3000°F is presented. The report also includes detailed information on the development of the sensor, fabrication of a probe, and a discussion of thermocouple attachment methods to non-metallic surfaces.

This technical documentary report has been reviewed and is approved.

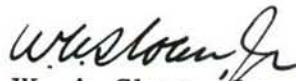

W. A. Sloan, Jr.
Colonel, USAF, Structures Division
Air Force Flight Dynamics Laboratory

TABLE OF CONTENTS

Section	Page
I INTRODUCTION	1
II THE BASIC APPROACH	3
III THE 1000°F SYSTEM - DESIGN, OPERATION AND PERFORMANCE	5
A. Design of the 1000°F System	5
1. Probe	6
2. D.C. Amplifier	7
3. Power Amplifier	7
4. D.C. Power	10
5. Temperature Read-Out	10
6. Auxiliary Equipment	10
B. Operation of the System	13
C. Performance Characteristics	15
1. Summary	15
2. Accuracy	16
a. Aluminum	16
b. Magnesium	18
c. Hot Rolled Steel	19
d. Stainless Steel	20
e. Titanium	21
f. Non-Metals	22
3. Response Time	24
4. Probe Orientation	26
5. Shadowing	31
IV COMPARISON OF PROBE AND SURFACE THERMOCOUPLE PERFORMANCE	33
1. Conclusions	33
2. Test Configurations	33

TABLE OF CONTENTS (Cont.)

Section	Page
3. Effect of Heating Rate	35
4. The Effect of Wire Size	36
5. Effect on Various Materials	37
a. Aluminum	37
b. Stainless Steel	38
c. Titanium	41
d. Magnesium	42
e. Non-Metals	43
6. The Effect of Orientation	44
V A 3000°F SURFACE TEMPERATURE MEASURING PROBE	46
1. The Sensor	46
2. The Power Amplifier	50
VI BIBLIOGRAPHY	51
Appendix	
A DEVELOPMENT OF THE SENSOR	52
B FABRICATION PROCEDURE	66
C ATTACHMENT OF THERMOCOUPLES TO NON-METALS	70
TABLES OF DATA	73

LIST OF ILLUSTRATIONS

Figure		Page
1	Temperature Sensor	4
2	Block Diagram of the System	5
3	The 1000°F System	6
4	Surface Temperature Probe	7
5	1000°F Probe Sensor	8
6	Power Amplifier	9
7	Test of 36 Gage Chromel-Alumel Surface Thermocouple on Stainless Steel	11
8	Experimental Test Equipment	12
9	Transient Tests on Aluminum	17
10	Steady State Tests on Aluminum	17
11	Performance on Anodized Aluminum	18
12	Intermittent Transient Tests on Magnesium	18
13	Steady State Tests on Magnesium	19
14	Probe Accuracy on Hot Rolled Steel	19
15	Probe Accuracy on Stainless Steel	20
16	Steady State Performance on Stainless Steel	21
17	Intermittent Transient Tests on Titanium	21
18	Steady State Performance on Titanium	22
19	Intermittent Transient Tests on Fiberglas Laminate of CTL Resin	22
20	Performance Tests on Lava	23
21	Results of Response Tests on Constant Temperature Surface	24
22	Comparison of Time Constant Equation with Data	25
23	Response of Surface Temperature Probe to a Severe Ramp Rise	27
24	Graphical Corrections for Time Lag	28
25	Probe Operated Against Vertical Plate	29
26	Orientation Tests on Stainless Steel	30

LIST OF ILLUSTRATIONS (Cont.)

Figure		Page
27	Orientation Tests on Aluminum	30
28	Orientation Tests on Hot Rolled Steel	30
29	Orientation Tests on Stainless Steel	31
30	Effect of Shadowing on Stainless Steel	32
31	Shadowing Effects on Plastics	32
32	Surface Thermocouple Installation	34
33	Effect of Rate of Heating	36
34	Effect of Wire Size	37
35	Performance of Various 36 Gage Thermocouples on Aluminum	38
36	Comparative Tests on Stainless Steel	38
37	Tests on Stainless Steel	39
38	Transient Test on Stainless Steel	40
39	Comparative Tests on Titanium	41
40	Comparative Tests on Magnesium	42
41	Comparative Tests on Plastics	43
42	Effect of Orientation on Aluminum	44
43	Effect of Orientation on Stainless Steel	45
44	Output of Various Thermocouples	47
45	3000°F Probe Sensor	49
46	Power Requirements of Heater	54
47	Voltage Characteristics of the Controller	55
48	Heater Response vs Power	56
49	Temperature Response of the Surface Probe System	58
50	Surface Temperature Probe Model 1	59
51	Intermediate Sensor Design	60
52	Sensor	61
53	Sensor Support	61
54	Probe Response Data	62

LIST OF ILLUSTRATIONS (Cont.)

Figure		Page
55	Continuous Contact on Aluminum	63
56	Effect of Shield on Reflective Heating	64
57	Sensor Support	66
58	Heater Installation	66
59	Sensor	68
60	Sensor	68

I. INTRODUCTION

The development of advanced flight vehicles has continuously introduced aerodynamic heating problems of ever-increasing severity. Inherent with aerodynamic heating problems are those of structural design which must take into account the complex effects of materials deterioration and of thermal stresses. It is imperative that important structural configurations be heated in a manner simulating typical aerodynamic heating flight paths in order that their structural integrity may be studied. In carrying out such studies it has been found most convenient to heat typical structures using radiation devices. Further, it has been found most convenient in making temperature measurements on such structures to attach thermocouples to the surface of the heated object. Because perturbations of varying intensity may be caused by the attachment of such external instrumentation, it was considered highly desirable to develop a device which would be capable of measuring the true surface temperature at any point being so heated and which would not have the usual distortions generated by permanent installations. It was considered very advantageous to have a device which could be used intermittently to monitor areas where no permanent installations were available, to monitor the performance of permanent installations, or to replace a normal installation when it became defective in operation. In setting up the requirements which were needed for such a system, the characteristics listed below were set as a goal:

1. A capability of being operable from ambient to 1000°F, with the potential of extension to 3000°F.
2. An accuracy of 3/8 percent below 1000°F and 1/2 percent above this temperature.
3. A capability of following ramp-rise rates to 150°F per second.
4. Applicable for use on aluminum, steel, nickel, titanium, magnesium, various alloys of these metals, and certain non-metallic materials.
5. Readily portable.

(Manuscript released by the authors July 1963 for publication as an RTD Technical Documentary Report.)

6. Not require any modification of the monitored surface, or cause a modification of the surface.
7. Not require access to surfaces other than the one exposed to thermal radiation.
8. Cause negligible shadowing of the thermal radiation from the heaters to the surface.
9. Withstand normal strains of operation and other conditions incident to shipping, storage, installation, and service without failure.
10. Operate satisfactorily at all humidities up to and including 100 percent.
11. Be capable of accurate operation in any orientation.
12. Have good reliability.
13. Operate using 110 to 120 volts a. c. 60 cycle single phase or 24 volts d. c.

In attacking a problem of this nature, a variety of approaches were considered. Optical techniques were eliminated because of the practical inability to know the surface characteristics of the material under all conditions and because of the problem of resolution to very minute areas. Preliminary analysis indicated that a probe which touches the surface and which has an extremely small tip was the most practical approach.

An instrument which operates on this contact principle has been developed to meet most of the prescribed goals outlined above without calibration. The details of the research and development program which was required to accomplish this end are presented in this report.

II. THE BASIC APPROACH

The measurement of surface temperature is extremely difficult because there are errors which are not easily controlled in almost every system. For example, in systems which use thermocouples attached to the surface under radiant heating, lead wires coming from the thermocouple junction tend to conduct heat away from or to the surface at the point of measurement resulting in errors in the temperature measured. If these lead wires are large, the errors tend to be large. If they are minute, the errors are reduced. Important also is the contact to the surface. Those thermocouples which are welded to the surface and intimately attached tend to read more accurately than those relatively loosely attached. Under conditions of radiant heat transfer, in order to have a correct reading at the surface, the materials from which the thermocouples are made need to have the same radiation characteristics as those of the surface to which it is attached. This is often difficult to achieve. The combination of effects tends to eliminate any easy approach to a solution of the problem.

One method utilized at CAL in 1949 eliminated most of these objections but was cumbersome to operate. This was known as the "heated thermocouple." In its operation, an estimate was made of the temperature of the surface which was to be measured. A thermocouple unit with its lead wires heated by an external heater was then brought to the estimated surface temperature. Immediately upon contact of this thermocouple with the surface, any temperature unbalance was indicated by deflection of a galvanometer. By suitably adjusting the power to the heater, and recontacting the surface, the amount of temperature unbalance was reduced. By tedious multiple attempts to achieve negligible temperature unbalance, a temperature reading of high precision could be obtained.

The heated thermocouple method as presented above solved many of the problems associated with surface temperature measurement with one paramount exception, that is, it did not permit the measurement of transient surface temperatures. It did, however, permit the desired accuracies and eliminated the perturbations normally caused by permanent installations. The method selected for development is related fundamentally to the heated thermocouples. The development consists of modifications which permit transient temperatures to be measured with extreme speed.

The system selected for development is illustrated in concept in Figure 1. In this system, a sensor composed of two thermocouples and a

heater, sandwiched together with insulative separators, is placed at the tip

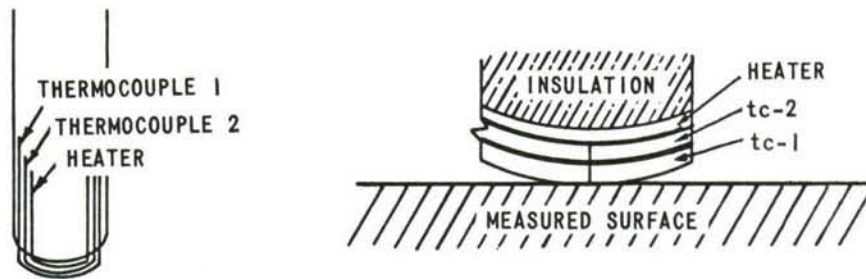

Figure 1 TEMPERATURE SENSOR

of a thin pencil-like support or probe. The appropriate lead wires are connected to a power source and to a controller. The thickness of the heater and the thermocouple units is small compared with their width and length. In operation, the probe is pressed against a surface to be measured. Thermocouple No. 1 instantly begins to approach the temperature of the surface but does not reach it because of the heat losses back through the probe. Thermocouple No. 2, therefore, senses a different temperature than thermocouple No. 1. When this unbalance is related to the controller, heat is generated in the heater unit. Because of their relative positions, the heater unit has more influence on thermocouple No. 2. Heat generation continues until thermocouple No. 1 and thermocouple No. 2 are equal in temperature and at this time the controller turns off the heater. This control action continues, causing the two thermocouple readings to remain equal. When the two thermocouple readings are the same, no heat flows between the measured surface and the probe system, and the thermocouples indicate the surface temperature. This temperature is then either indicated or recorded on appropriate instrumentation. Thus, the sensor is simply a device which is automatically controlled so that there is no heat flow at the measuring thermocouple in contact with the surface to be measured.

III. THE 1000°F SYSTEM - DESIGN, OPERATION AND PERFORMANCE

A. Design of the 1000°F System

The complete system now used to record surface temperature consists of a probe, D.C. power source, D.C. amplifier, power amplifier and recording instrument. This system is illustrated in Figure 2 below:

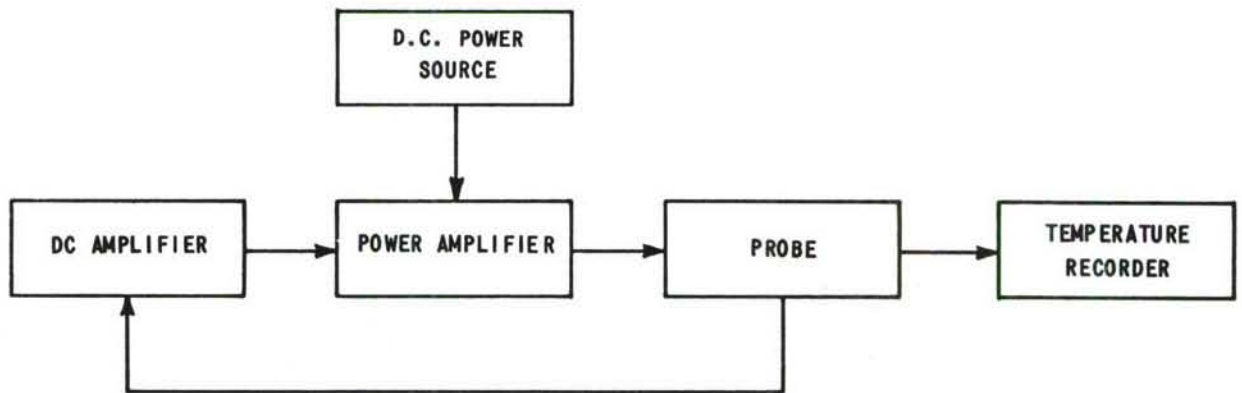

Figure 2 BLOCK DIAGRAM OF THE SYSTEM

In operation, the probe is touched to a hot surface and senses a temperature unbalance indicating heat flow at its sensor. The unbalance signal, amplified by the D.C. amplifier goes to the power amplifier which calls for power from the D.C. power source. This power at any instant is proportional to the magnitude of the unbalance of the sensor. This power heats the probe tip to correct the unbalance. As the unbalance approaches zero, the power amplifier diminishes the energy input to the heater until a "steady state" no heat flow condition exists at the sensor. The true surface temperature indicated by a thermocouple at the probe sensor, is then recorded.

The items in the present system are discussed individually below and each is shown in Figure 3.

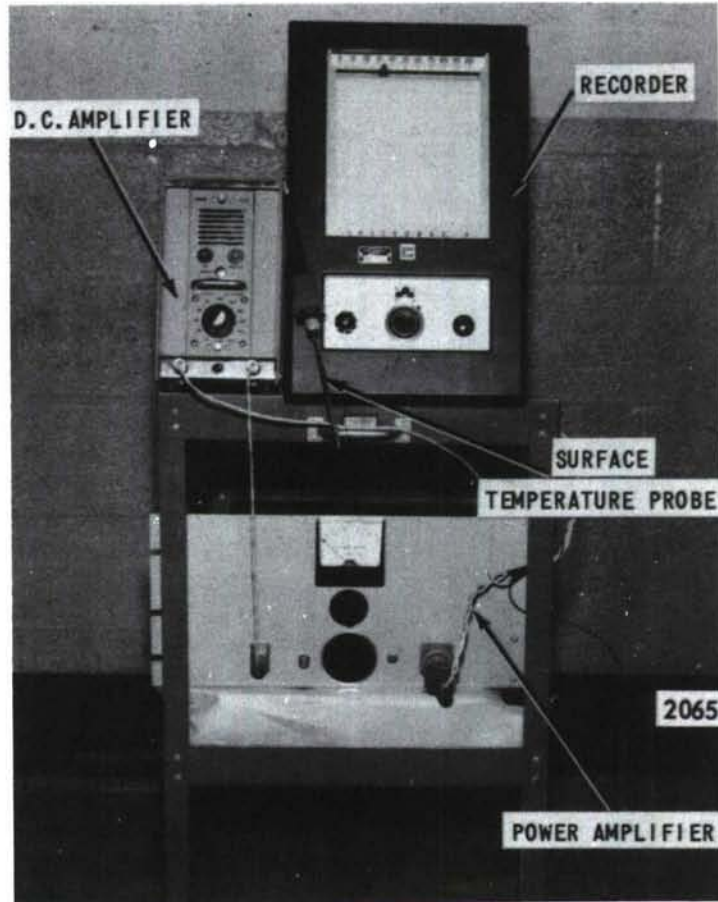

Figure 3 THE 1000°F SYSTEM

1. Probe

The present probe pictured in Figure 4 consists of a ceramic sting, sensor and connector. The ceramic sting contains six holes through which the lead wires of the sensor pass to the receptacle. The sting has a thin coating of gold whose high reflectivity prevents overheating of the probe during exposure to radiant heat sources.



Figure 4 SURFACE TEMPERATURE PROBE

The sensor is shown in Figure 5. It consists of a thermocouple system which permits a readout of the tip temperature and in addition gives a signal of the magnitude of any temperature unbalance between the differential thermocouples on either side of the miniature ceramic spacer. It also contains a platinum heater which is energized by current metered from the power amplifier.

This description of the probe is kept brief to avoid repetition. A detailed discussion of probe design evolution is presented in Appendix A and a detailed description of the probe fabrication procedure is given in Appendix B.

2. D. C. Amplifier

To amplify the temperature unbalance signal from the probe, a modified Kintel Type 111A D. C. amplifier has been used. Two rather simple modifications were made:

1. To increase gain by 10 (to 10,000) the R306 - 1 megohm resistor was shunted by a 100,000 ohm resistor.
2. To decrease the bandwidth to $\cong 15$ cps, the C308 - 3 $\mu\mu\text{f}$ capacitor was shunted by a 0.1 μf capacitor.

3. Power Amplifier

A diagram of the power amplifier is shown in Figure 6. Transistors were selected for the two stage power amplifier package because of their ability to supply high power to low impedance loads. The input stage is primarily a driver stage employed to control the base current of the output stage. Over-all, this unit is capable of supplying more than 60 watts of continuous power at 6 volts applied emitter-collector voltage. To some extent, the power amplifier unit is an electronic switch in that conduction is achieved only when transistor input barrier potentials are overcome. The threshold level at which this "switch" closes is predetermined by the bias voltage control on the input stage. To preclude thermal runaway, the transistors are mounted on heavy heat sinks that are in turn forced-convection cooled. This feature assures

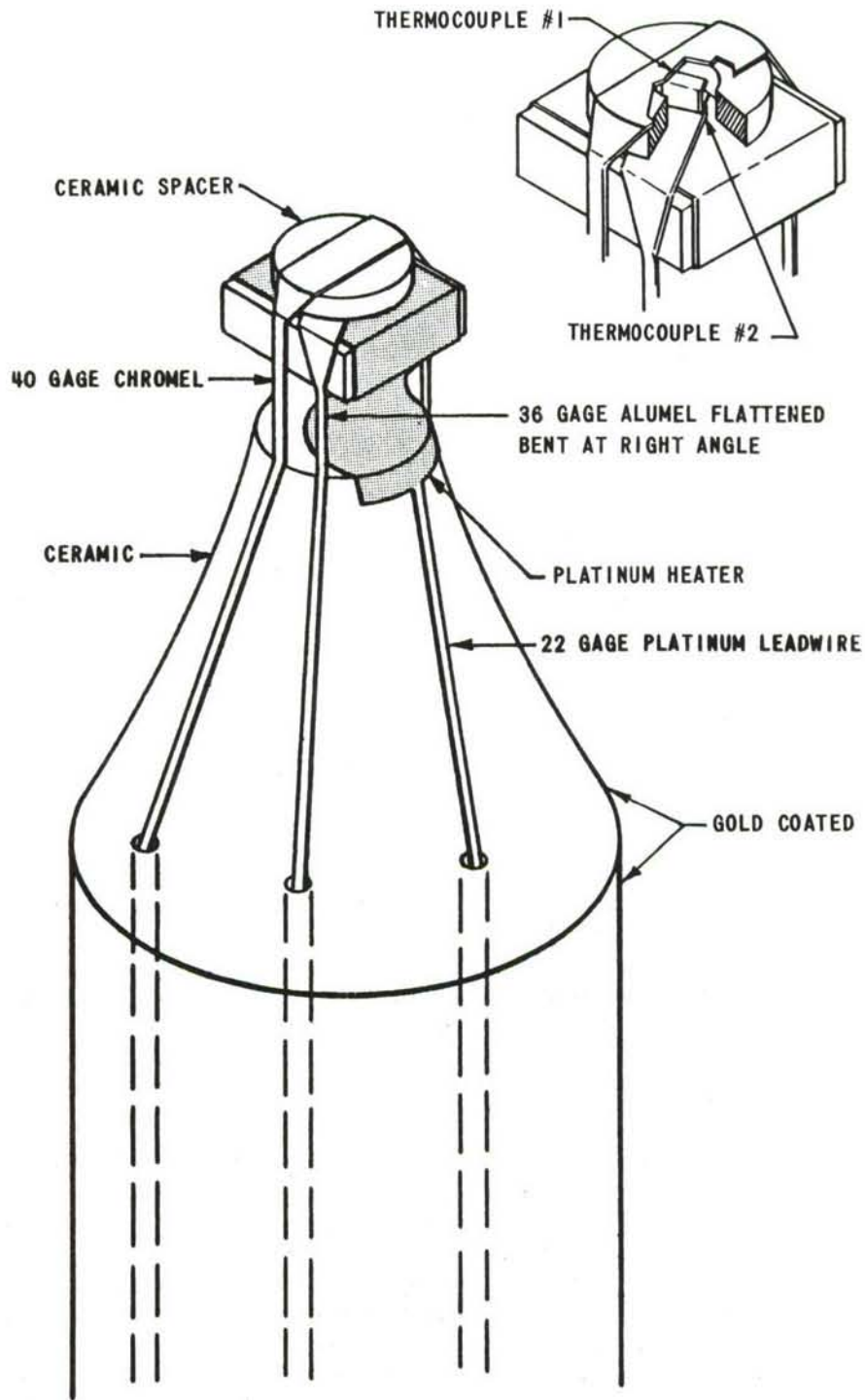

Figure 5 1000°F PROBE SENSOR

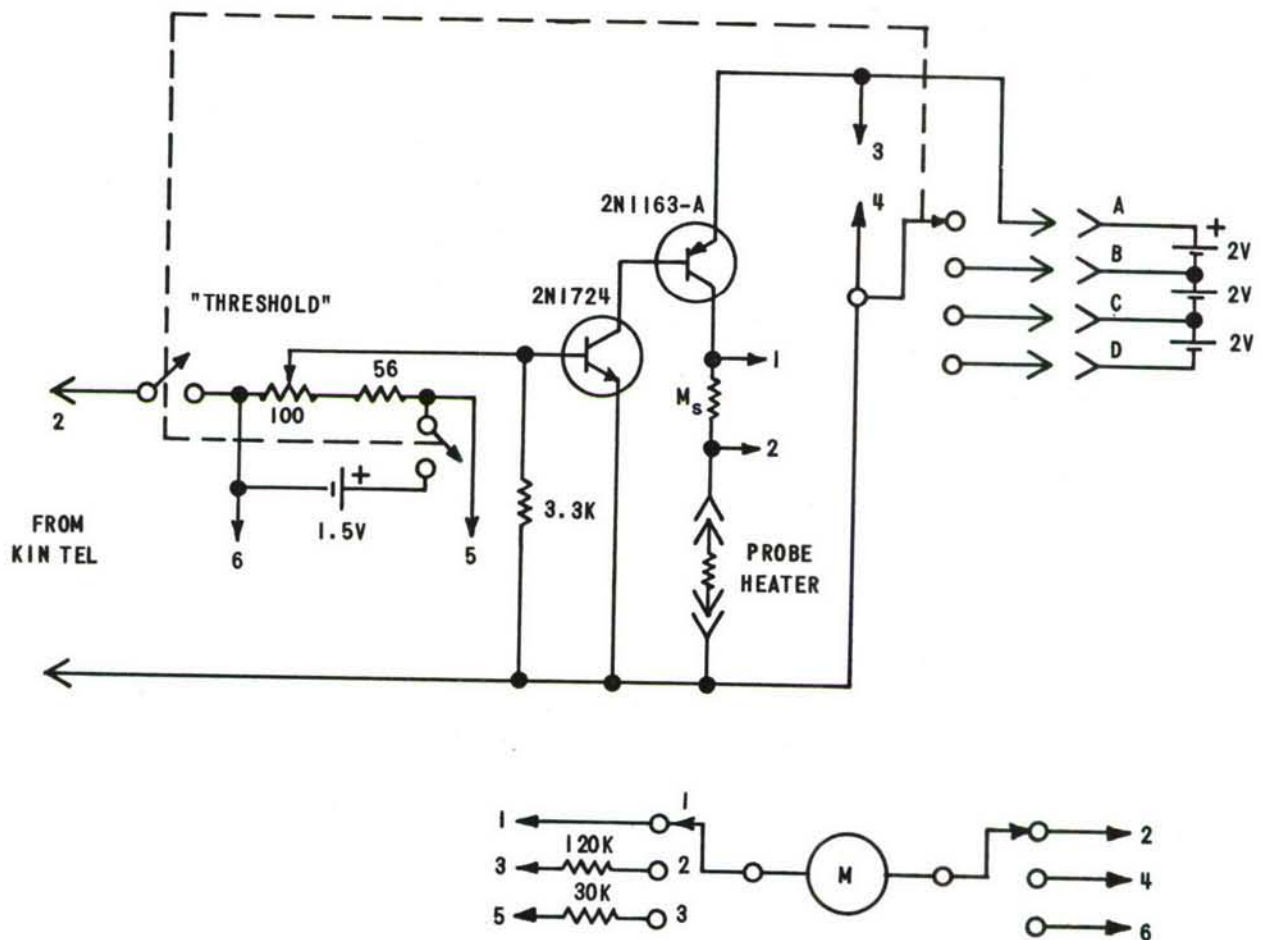

Figure 6 POWER AMPLIFIER

sole control by input error signals at all times. Although the preamplifier responds to signals of either polarity, the power amplifier unit responds only to positive polarity signals. Hence, only error signals requiring positive probe heating elicit control circuit response. Since the probe design embodies very low thermal lag in the thermal element, this feature insures absolute power cut off as soon as the error signal reverses polarity and thus enhances system stability.

The power amplifier and associated equipment which have been used in the development phase are considerably larger and more cumbersome than necessary for a surface temperature measuring device in actual operation. No attempt has been made to miniaturize or simplify the design because effort

had to be concentrated on the more difficult problem of achieving actual performance from the probe sensor using good controls from the power amplifier. The system as it is presently represented, of course, has great versatility for being used at a number of temperature ranges and on a variety of materials. If the application of the probe is restricted or limited, a great simplicity can be incorporated in the device. Further, as the stability of the D. C. system becomes less important, for example, in relatively short time application, the size and weight of various components can be decreased quite appreciably. It is believed therefore, that for many applications the control system can be greatly simplified and miniaturized.

4. D. C. Power

The basic D. C. power source is a 6-volt wet cell battery. This is connected to the controller through a switch that permits the choice of 2, 4, or 6-volts, but 4 volts have been used for all system evaluation tests. This item can be replaced by a rectifier which operates from a 110-volt A. C. line if desired.

5. Temperature Read-Out

For reading the probe sensor temperature, a Leeds & Northrup Model H AZAR recorder was used for much of the experimental work. For the fast response experiments, a Minneapolis - Honeywell Visicorder 906A Oscillograph was used and in much of the experimental work, the magnitude of temperature unbalance was read on a Tektronix 535 Oscilloscope.

6. Auxiliary Equipment

For much of the initial experimental work in which no irradiated surface was needed to determine probe performance, a standard surface temperature heater was fabricated. It is a one inch-diameter silver cylinder capable of operating at temperatures slightly above 1100°F. This heater is rheostat controlled and provides a variable uniform surface temperature. A calibrated thermocouple was installed 0.015 inches from the surface of the cylinder at the center.

To simulate the effects of a radiation heat source, a small radiation heating unit consisting of four five inch-long quartz infrared elements was used. These quartz elements are located in such a manner that when enclosed in their reflector, they will assume a position one inch from the surface of a test plate. A hole in the aluminum reflector allows the probe to be inserted and touched to the test plate. The test plate has the dimensions of 5" x 6" with a variety of thicknesses depending upon the individual test and material. Up to five 40-gage chromel-alumel thermocouples were carefully installed in each plate under the surface away from the radiant heat source. For each material, the thermocouples were calibrated to assure their reproduction of accurate temperatures. Further, the method of installation was such that heat losses in the thermocouple leads were minimized.

Thermocouples were calibrated at the boiling and freezing points of water and the freezing point of lead (621.5°F). The calibrations in water were made after installation into the equipment. The thermocouple calibrations in lead were made on the individual thermocouple before installation. Agreement with emf output tables was consistently excellent and therefore higher melting point calibrations were not made.

In operation, several types of tests were conducted and are described fully in later sections. One of these test conditions is the steady-state. In this situation the radiation heater is turned on and permitted to approach an equilibrium temperature so that the reference plate temperature is constant. Then the probe is touched to the surface and recordings are made of its performance.

In many of the tests, transient conditions were studied. Under these conditions, the desired rate of rise of temperature of the monitored surface was adjusted by appropriate settings on a variable rheostat. Through a switching arrangement, the probe or any other thermocouple installation, could be monitored while the test was progressing. Thus, a recording such as that shown below (Figure 7) could be made. As shown, individual segments were

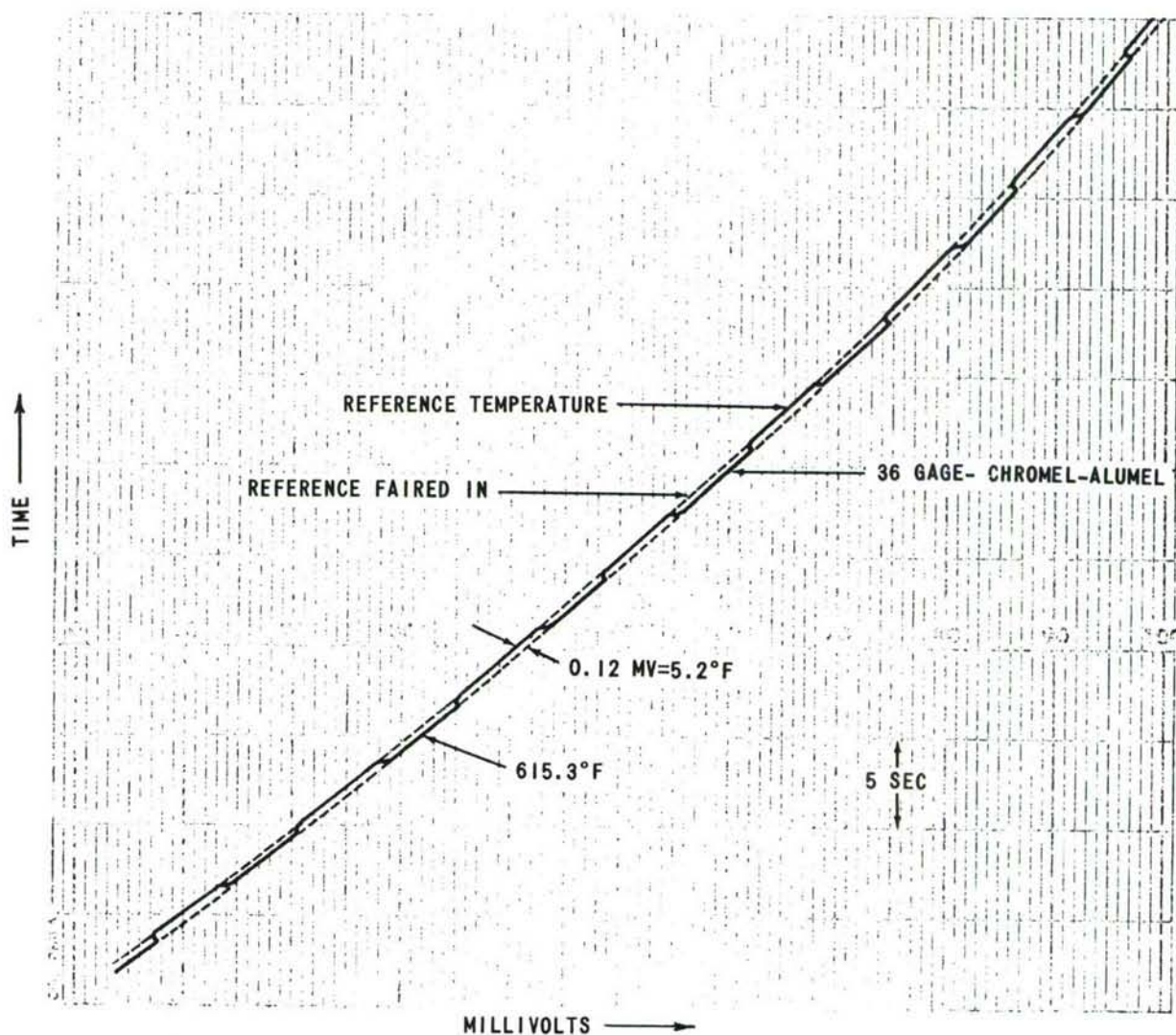

FIGURE 7 TEST OF 36 GAGE CHROMEL-ALUMEL SURFACE THERMOCOUPLE ON STAINLESS STEEL

connected to make a continuous line of each of the individual circuits being monitored in order that at any one instant the appropriate temperature could be tabulated. When extremely rapid response tests were being made using the Visicorder, all channels were recorded simultaneously and therefore no switching was required.

A photograph of a typical experimental test including the auxiliary equipment is shown in Figure 8.

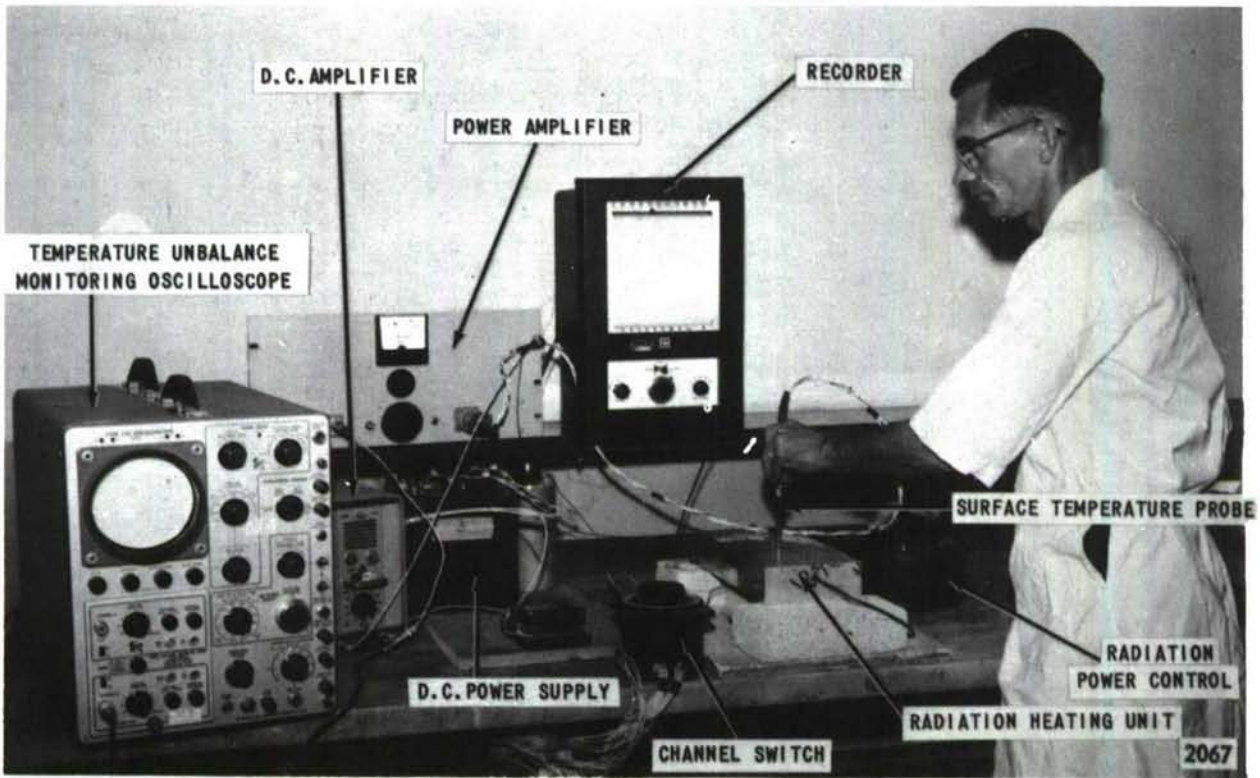

Figure 8 EXPERIMENTAL TEST EQUIPMENT

B. Operation of the System

The operation of the system requires the following steps:

1. Turn on the power to the D. C. amplifier, power amplifier and recorder and allow 15 minutes to warm up.
2. Select the gain on the D. C. amplifier.
3. Turn on the probe switch and touch the probe to the surface to be measured.

Step 2 is the only one that requires any adjustment. The recommended settings, which depend only on the material* used, are given below:

<u>Material</u>	<u>Gain</u>
Aluminum	2,000
Magnesium	1,000
Hot Rolled Steel	2,000
Stainless Steel	3,000
Titanium	2,000
Ceramics	3,000
Plastics	7,000

Barring a malfunction of the electronic system, once the above procedure has been followed, there is no danger to the probe whether in use or not. With the whole system turned on and the probe laying on a table, the system will simply measure the temperature of the air or anything with which the probe is in contact.

*The dependency of the gain adjustment of the D. C. amplifier on the individual materials is confined primarily to optimizing the time response of the system. If too high a gain is used, an overshoot will occur immediately after contact. This will require power-off time to return within required limits of accuracy. If too low a gain is used, the time response will also be poor because more time will be required to reach acceptable limits of accuracy. The sensitivity of the system to the gain adjustment is not great and a setting $\pm 100\%$ from those listed will still produce acceptable accuracies. Although it has not clearly been determined, the "dependency" of system response performance on materials properties is believed to concern thermal diffusivity and reflectivity.

The contact pressure which the operator should use can best be described in the following qualitative terms. The probe should be touched to the measured surface with enough pressure to maintain its location without shifting. Because the tip has such a small area, normal hand pressure will produce a rather high force per unit area. Excessive pressure should be avoided to prevent damage to the sensor. This qualitative description is considered to be adequate inasmuch as successful measurements were made by several inexperienced operators who were so instructed.

In operation, it may sometimes be noted that temperatures higher than the surface temperature are recorded while the probe is in a radiant environment and is either approaching or receding from a reflective surface. This was noted with an aluminum surface. It initially caused concern because of the possibility that this might represent some "run away" condition which would overheat the probe and damage it. Investigation proved this fear to be unfounded. In tests with an aluminum plate at 960°F, the probe was found to stabilize, after 10 or 12 seconds, at approximately 1160°F when it was close to but not touching the surface. (Tests were made at 1/32" and 1/16").

C. Performance Characteristics

During the entire development operation, and particularly as the development approached its present state, effort was made to evaluate the operational characteristics of the probe under almost any set of circumstances. A comprehensive program of tests was run to assure reliability of operation and to minimize the possibility that undesirable performance characteristics might exist. These tests included the following types:

1. Steady State

These are tests in which the probe sensor was in continuous contact with a test material at constant temperature.

2. Intermittent Steady State

These are tests in which the probe sensor was contacted intermittently for short duration to a test material at constant temperature.

3. Transient

These are tests in which the probe sensor was in continuous contact with a test material of increasing temperature.

4. Intermittent Transient

These are the tests in which the probe sensor was contacted intermittently for short duration to a test material of increasing temperature.

In the tests which are reported on the following pages, four probe designations (4C, 5A, 5Ar and 5B) are used. All of the No. 5 probes have the configuration shown in Figure 5. 5A and 5B are simply two probes of the same design. Probe 5Ar is probe 5A after the front sensing thermocouple had been repaired. Probe 4C is identical with the No. 5 probes except that the tip was not gold coated and was not "necked-down" just behind the sensor. On a few tests, a skirt was used at the sensor in which case this is so indicated.

The results are summarized briefly below and that is followed by greater detail with data substantiation.

1. Summary

The system has the performance capability of:

1. Accuracy generally 3/8 percent or better without calibration.

2. Successful operation on all metals and non-metals tested (including aluminum*, magnesium, hot-rolled steel, stainless steel and titanium).
3. Operation in both intermittent and continuous contact.
4. Operation on surfaces at constant and transient temperatures.
5. Operation governed by a time constant of the order of 0.1 seconds (three probes had 0.11-, 0.15-, and 0.08-second time constants).
6. Providing accurate readings during ramp-rise rates of 47°F/sec. Accurate determination of temperatures during ramp-rise rates of hundreds of degrees per second is achieved by graphical techniques.
7. Operation without significant shadowing.
8. Accurate operation in a variety of orientations.

2. Accuracy

At the beginning of this development an accuracy of 3/8 percent was set as a goal for the measurement of surface temperatures ranging from ambient to 1000°F. This is equivalent to a deviation at full scale of 3.75°F. For practical purposes this performance level has been reached and, in most cases, surpassed. This can be observed in the information that follows.

a. Aluminum

The probe performs well during transient tests on aluminum. This is demonstrated in Figure 9 by the data points of a single representative test performed with the latest model probe using a gold coated sting and tip. During the 20 transient tests conducted, the maximum spread did not exceed 6°F and the average deviation was less than -2°F.

* Because of its high reflectivity, aluminum surface temperatures may read as much as 5°F high after one minute of continuous contact on a surface at constant temperature and this may be followed by a slow rise to as much as 8°F high.

DATA ARE TABULATED ON PAGE 73

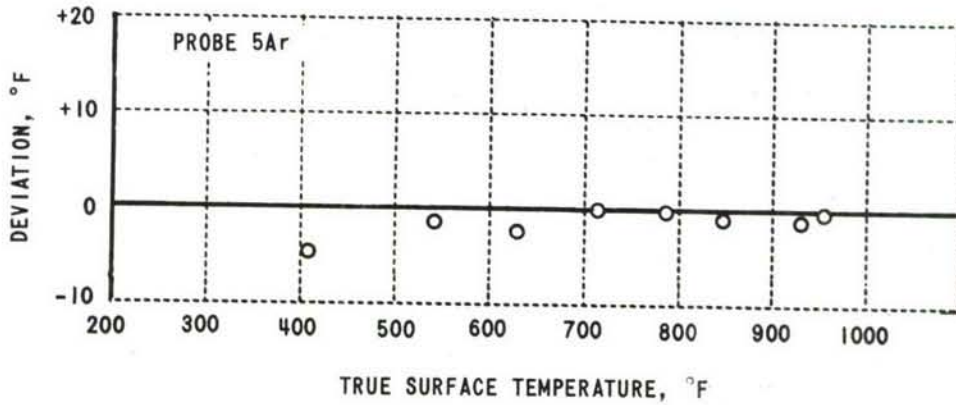

Figure 9 TRANSIENT TESTS ON ALUMINUM

During continuous contact tests on an aluminum surface, the system gives readings within the normal range of accuracy for over 30 seconds and then tends to drift slightly higher. This is illustrated by the data in Figure 10 below which represents two steady state temperature levels, 510°F and 860°F. Note that the greatest deviation was +5°F at one minute after contact and the maximum deviation plateau was +7°F. The greatest deviation observed in all 20 tests was +8°F.

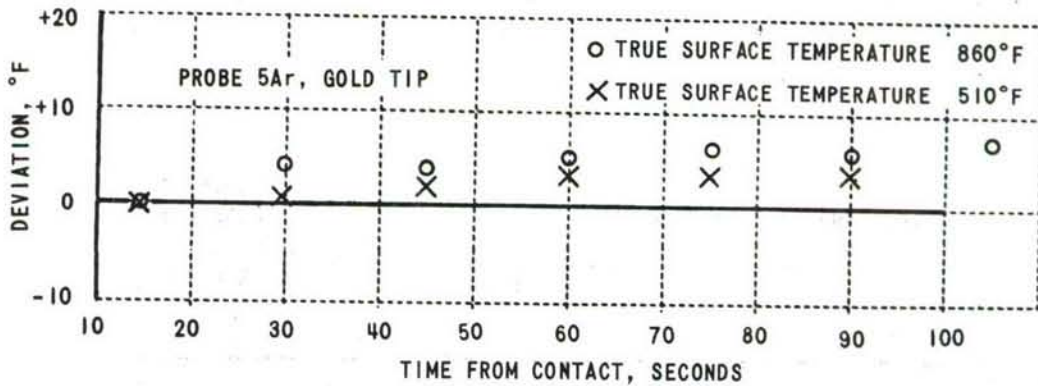

Figure 10 STEADY STATE TESTS ON ALUMINUM

The above steady state-continuous contact performance is caused by the high reflectivity of the aluminum which permits the probe to heat slightly faster from the radiant energy. This effect was minimized to the above performance levels by using gold coated probes. Since the probe tip was also gold coated, no skirt was needed. An experiment that substantiated the validity of the above explanation is shown in the data of Figure 11. In this case, an identical aluminum plate whose surface was anodized to decrease the reflectivity did not show the slow upward change in deviation. Note that the temperature decreased slightly when the power to the probe was shut off.

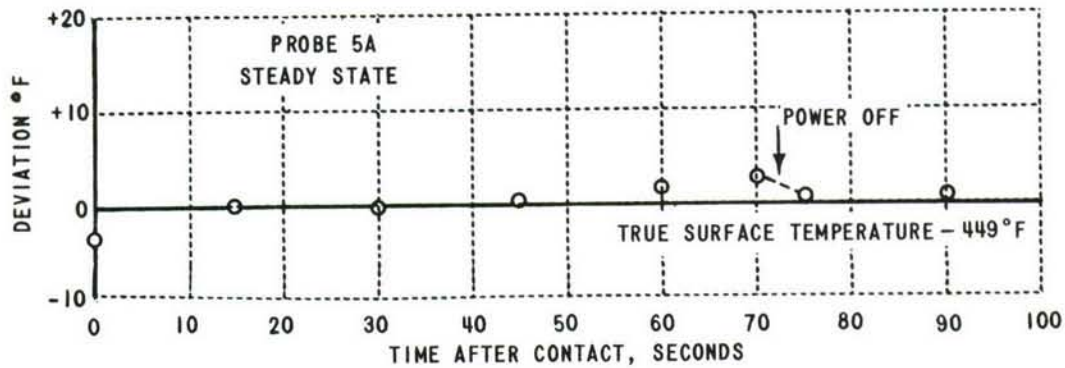

Figure 11 PERFORMANCE ON ANODIZED ALUMINUM

b. Magnesium

Experiments with magnesium produced results which show satisfactory operation in both transient and steady state operation. The results of intermittent readings taken during transient heating of the test plate are shown in Figure 12 below.

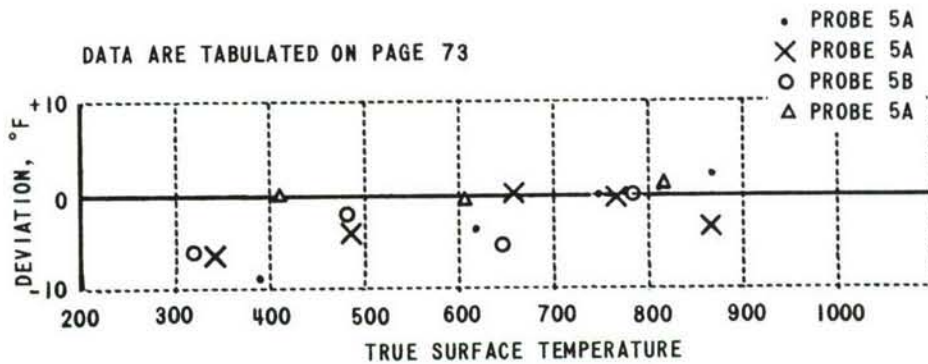

Figure 12 INTERMITTENT TRANSIENT TESTS ON MAGNESIUM

The probe's satisfactory operation under steady state conditions is illustrated in Figure 13 below. The results of eight other tests were similar. Demonstrated in the figure is the capability of the probe to maintain a reasonably constant temperature and then, when power to the probe heater is shut off, to cool. This demonstrates that the magnesium is not excessively reflective and tends to heat at a faster rate than the probe sensor materials when subjected to radiant heating.

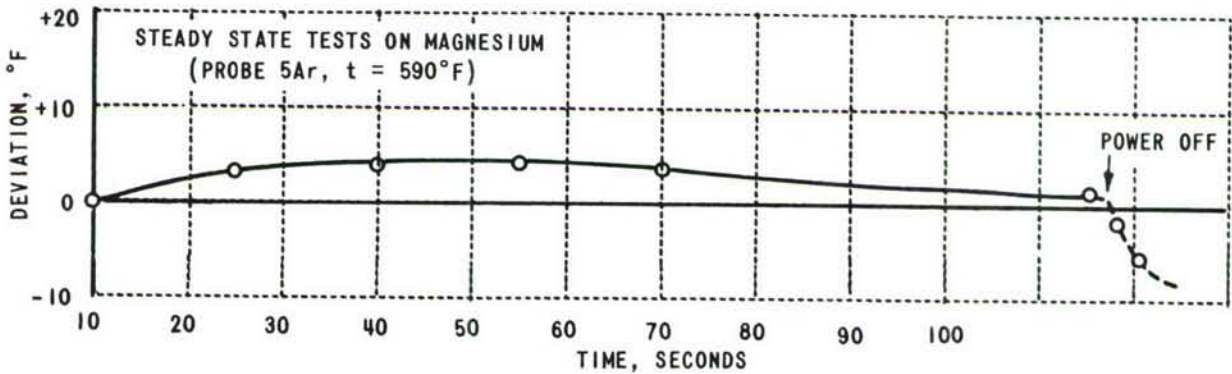

Figure 13 STEADY STATE TESTS ON MAGNESIUM

c. Hot Rolled Steel

Probe performance on hot rolled steel was excellent under both conditions of intermittent and continuous contact.

To illustrate the performance, Figure 14 is presented.

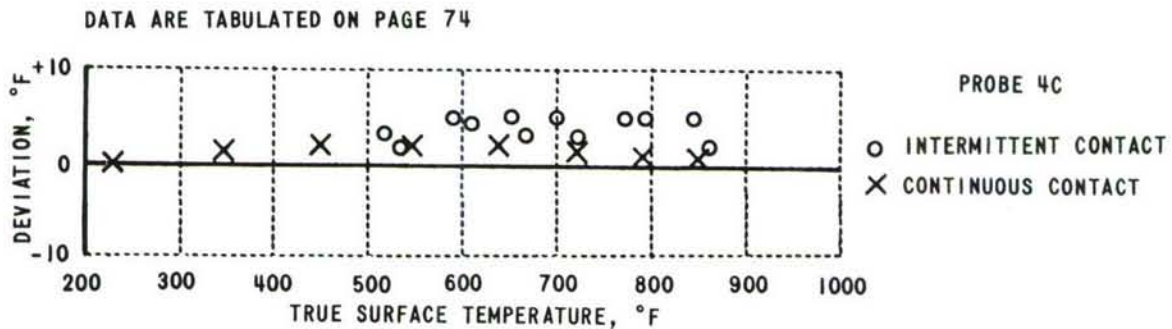

Figure 14 PROBE ACCURACY ON HOT ROLLED STEEL

Note that in intermittent contact the scatter was limited to a narrow band of 3°F and that in continuous contact, the maximum deviation was limited to +2°F.

None of the reflection effects noted on aluminum were experienced.

d. Stainless Steel

Twenty five test runs were performed on stainless steel, partly because it represented a metal of very low thermal conductivity and, therefore, might exhibit extreme characteristics. Some of these tests are discussed in other sections of this report such as those concerned with shadowing and orientation.

The accuracy resulting from tests performed on stainless steel was rather good - approaching that of hot rolled steel in both intermittent and continuous contact. This can be observed in Figure 15 below. Note that the

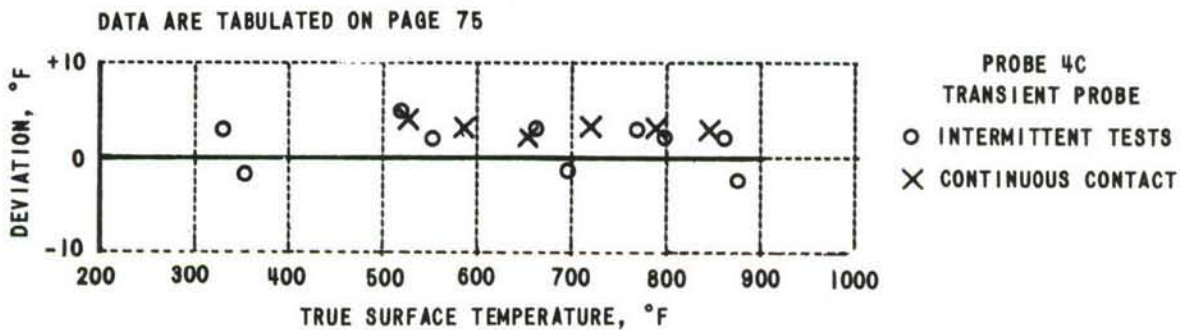

Figure 15 PROBE ACCURACY ON STAINLESS STEEL

maximum deviation under intermittent contact was +5°F and that the maximum spread in continuous contact was only 2°F. The performance of the surface temperature probe on stainless steel in steady state is illustrated in Figure 16 below. Note that the probe is quite accurate, showing a zero deviation much of the time. Note further that when the power was shut off, the temperature of the plate immediately diminished. This illustrates that there is no difficulty associated with radiant energy reflected from the surface of the stainless steel.

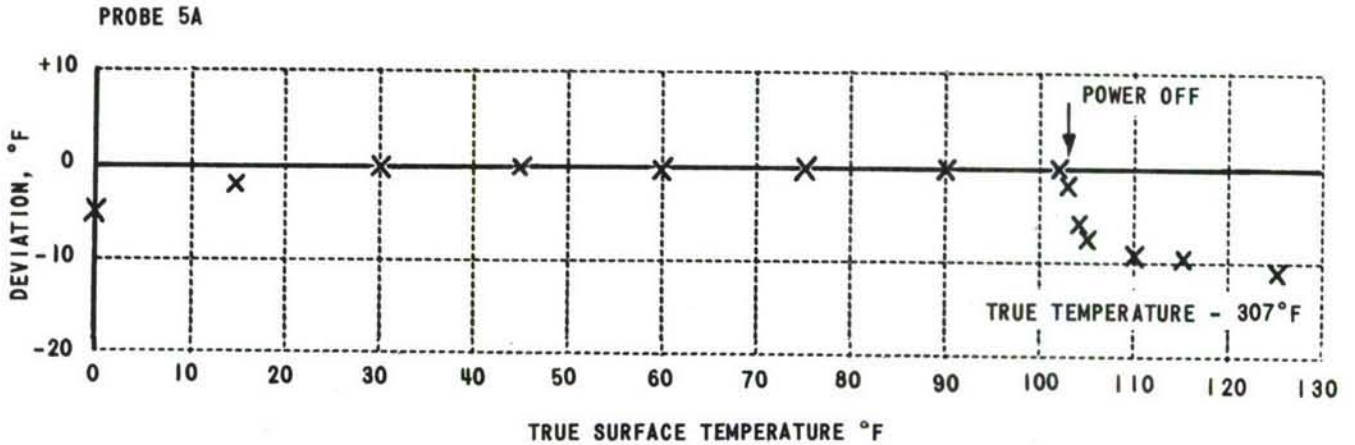

Figure 16 STEADY STATE PERFORMANCE ON STAINLESS STEEL

e. Titanium

Performance of the probe on titanium has shown generally satisfactory results in both intermittent and continuous contact operation as illustrated in Figures 17 and 18. Figure 17 below presents the results of two typical intermittent test runs. With the exception of one point, the greatest spread was less than 9°F and the average deviation was less than 1°F. The spread is slightly greater than was experienced with aluminum, hot rolled steel and stainless steel and somewhat comparable to the results with magnesium. This is perhaps caused by the fact that a different probe had to be used on magnesium and titanium. There is a tendency for the gold-tipped probes to read low near the beginning of a transient test as illustrated in Figure 17.

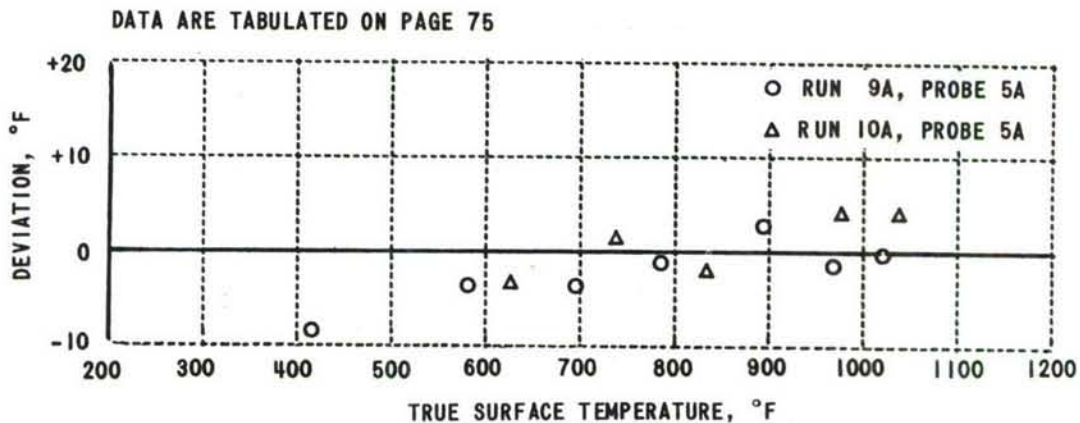

Figure 17 INTERMITTENT TRANSIENT TESTS ON TITANIUM

The probe when used with titanium has none of the reflected energy effects experienced with aluminum as illustrated in Figure 18 below. Note the rapid decrease in temperature experienced when the power from the controller was turned off.

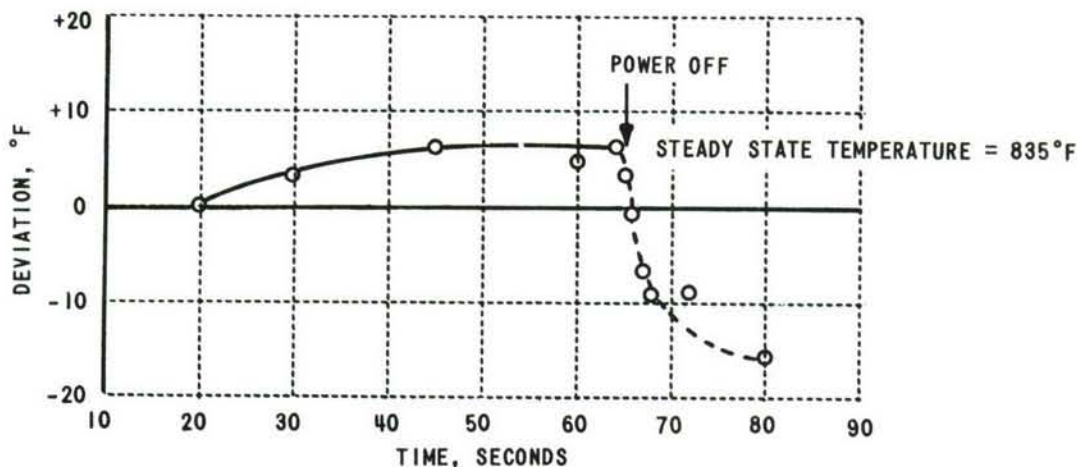

Figure 18 STEADY STATE PERFORMANCE ON TITANIUM

f. Non-Metals

For tests of the performance of the probe on plastics, a Fiberglas laminate with CTL resin was used. The reference thermocouple was imbedded one laminate from the face exposed to radiant energy. The results were generally comparable with the metals but, of course, only low temperature runs could be made. These tests are illustrated in Figure 19 below. As with titanium, the total spread (excepting one point) was 9°F and the average deviation was -1°F.

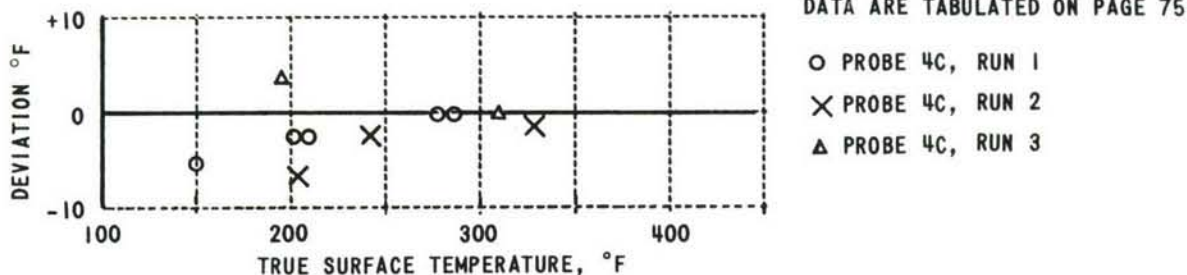

Figure 19 INTERMITTENT TRANSIENT TESTS ON FIBERGLAS LAMINATE OF CTL RESIN

More discussion of the performance on plastics is included in the section on Shadowing, page 32.

As a representative of ceramics, a lava plate 0.040" thick was instrumented for tests similar to those made on metals. Because of the extremely low thermal conductivity of the material, testing was confined to steady state conditions. Two tests were completed. The first at a surface temperature of 470°F is illustrated in Figure 20. Note that the probe performs very well. At the point of controller shut off, the temperature decreased unusually fast showing that the lava was absorbing the radiant energy much faster than the probe sensor.

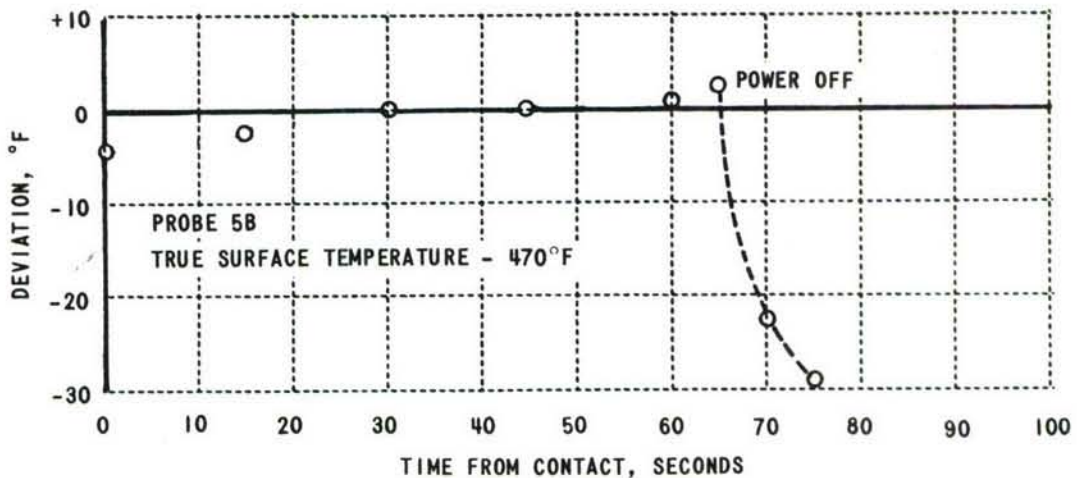

Figure 20 PERFORMANCE TESTS ON LAVA

Similar tests were performed at about 840°F with the following steady state readings:

<u>True Surface Temperature</u>	<u>Deviation °F</u>
840.5	-0.5
842.0	+2.5
843.5	+2.5

The probe was also successfully used on opaque microscope-slide, lime glass 0.037" thick. The results showed an average deviation at 400°F of less than 0.5°F over a range extending from -2.0°F to 0.0°F.

3. Response Time

The need for fast response in the surface temperature measuring probe is of major importance. During early tests of the probe, relatively poor response (of the order of seconds) was obtained. Initially, it was thought that contact resistance was a chief contributor to this poor response, but further experimentation revealed that the limiting factor was in the sensor design. Through improvements in the probe sensor, the time response has been improved very appreciably without a sacrifice of the other performance characteristics of the probe.

In order to evaluate the time response, two types of tests were made:

1. Tests in which the probe was touched to a surface maintained at constant temperature and the rate of temperature rise of the probe was recorded.
2. Tests in which extreme rapid rates of change of temperature were induced on a plate with which the probe was in continuous contact.

The results of the tests with the constant temperature plate and each of the last three probes constructed can be seen in the three curves below. These probes have time constants* determined from these tests of 0.11, 0.15, and 0.08 seconds.

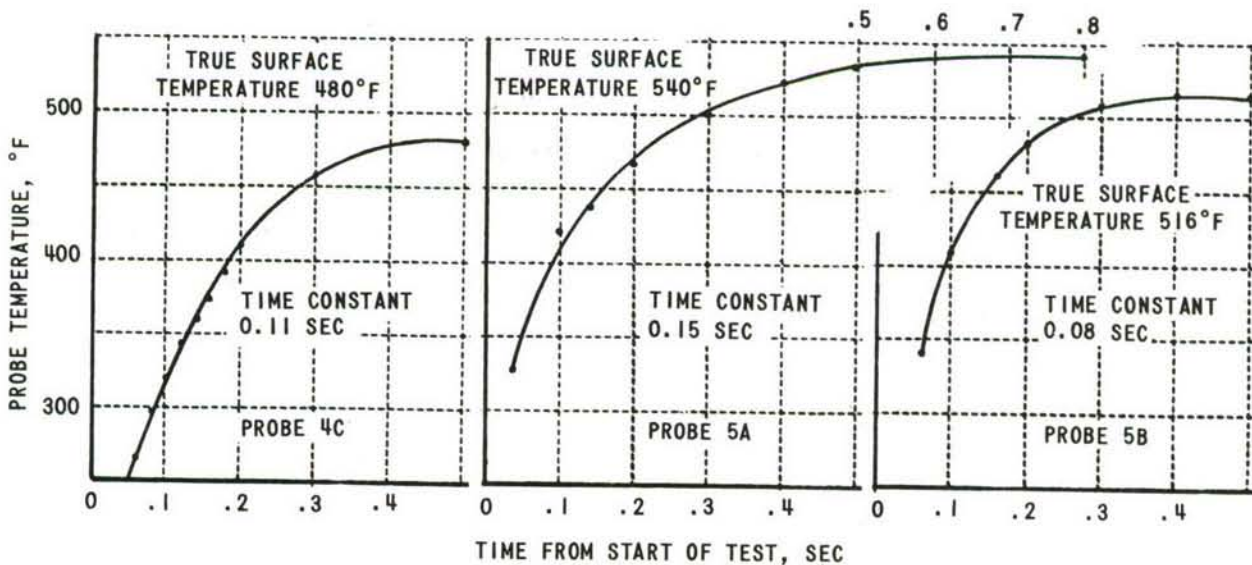

Figure 21 RESULTS OF RESPONSE TESTS ON CONSTANT TEMPERATURE SURFACE

*The time constant is an expression applied to processes which approach equilibrium logarithmically. The ratio of the distance from equilibrium at the end of one time constant to that at the start is 0.37.

When using a probe whose time constant is known on a surface at constant temperature, it is a simple matter to compute what the indicated temperature will be at any time by using the equation:

$$T_p = T_s - (T_s - T_i) e^{-\frac{t}{c}}$$

- where
- T_p = Probe temperature
 - T_s = Steady state surface temperature
 - T_i = Initial temperature
 - t = Time
 - c = System time constant.

The agreement of this computation with the data for Probe 5B can be seen in Figure 22. Thus, initial temperature rise data and a time constant is sufficient to predict a steady state temperature. The agreement between the theoretical equation and the experimental data is very significant in that it permits one to relate the behavior in the sudden step-wise change to that when the probe follows a steady, or ramp rise, change.

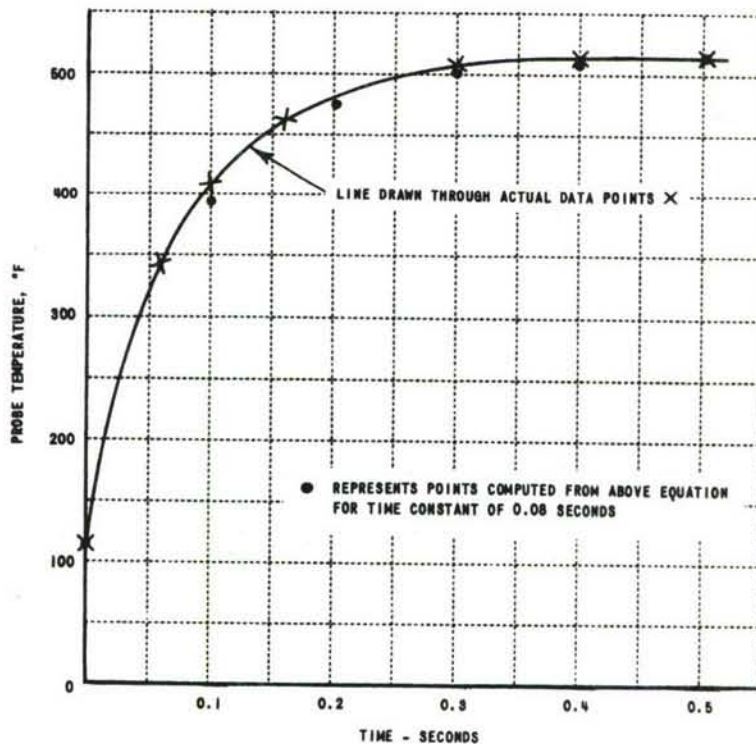

Figure 22 COMPARISON OF TIME CONSTANT EQUATION WITH DATA

An example of the results of severe ramp rise tests are shown in Figure 23. In these tests, Probe 4C was used to read the temperature of a stainless steel plate which was flame heated from the opposite side. Thermocouples mounted on the side of the plate measured by the probe were used as a reference for comparison purposes. Two widely separated rise rates are illustrated, 140°F/sec and 240°F/sec.

Note in Figure 23 that the time displacement between the reference and probe curves for both ramp rise rates is essentially the same. Also note that the time displacement is about 0.13 seconds which is in good agreement with the time constant for Probe 4C determined from the steady state experiments. This is a further demonstration of the validity of employing probe time constants in analysis with probe data because the time constant of the probe should be equal to the time displacement under ramp rise conditions.

Perhaps the simplest means of correcting for time lags in the probe is demonstrated in the illustration of Figure 24. In this illustration, it is assumed that a probe which has a calibrated time constant of 0.1 seconds records the solid temperature-time line shown in the figure. Then the true surface temperature is found by displacing the line to the left by 0.1 seconds.

The range of time constants, from 0.08 to 0.15, in the three probes shows that techniques of fabrication perhaps need to be improved for greater standardization. Further, the fact that there is a range, lends encouragement to the possibilities that the time constants can be improved even further.

To summarize the response time performance, the following statements can be made:

1. A system time constant of 0.08 seconds has been achieved.
2. Because of the fast response, for most applications, any system time lags can be ignored.
3. Where the time lags are considered to be too great, simple graphical means can be used to determine true surface temperatures.

4. Probe Orientation

All of the tests which refer to accuracy were reported in readings from a standard plate in the horizontal position. The readings were taken on the upper surface of this horizontal plate. Additional tests were made with the plate

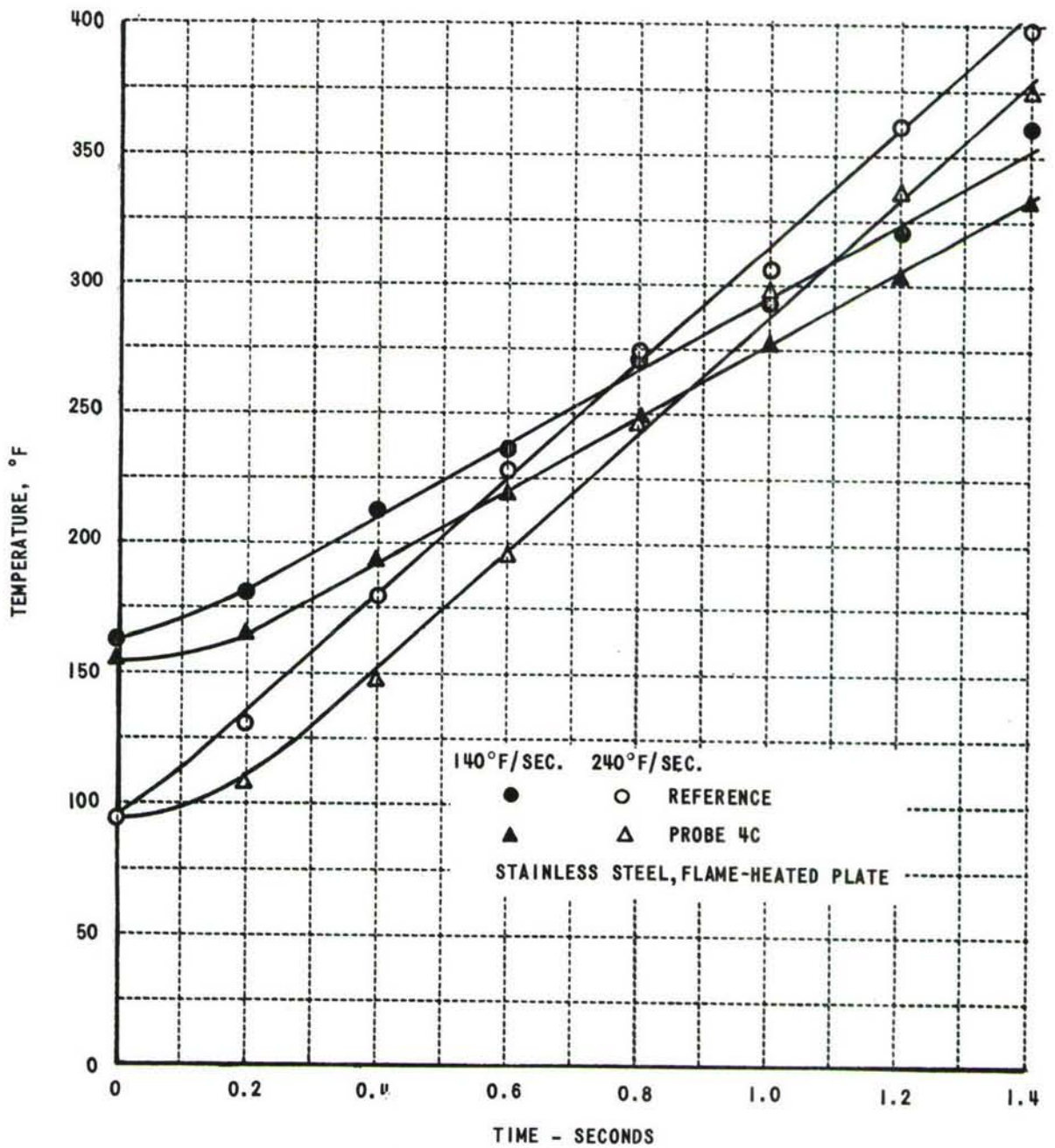

Figure 23 RESPONSE OF SURFACE TEMPERATURE PROBE TO A SEVERE RAMP RISE

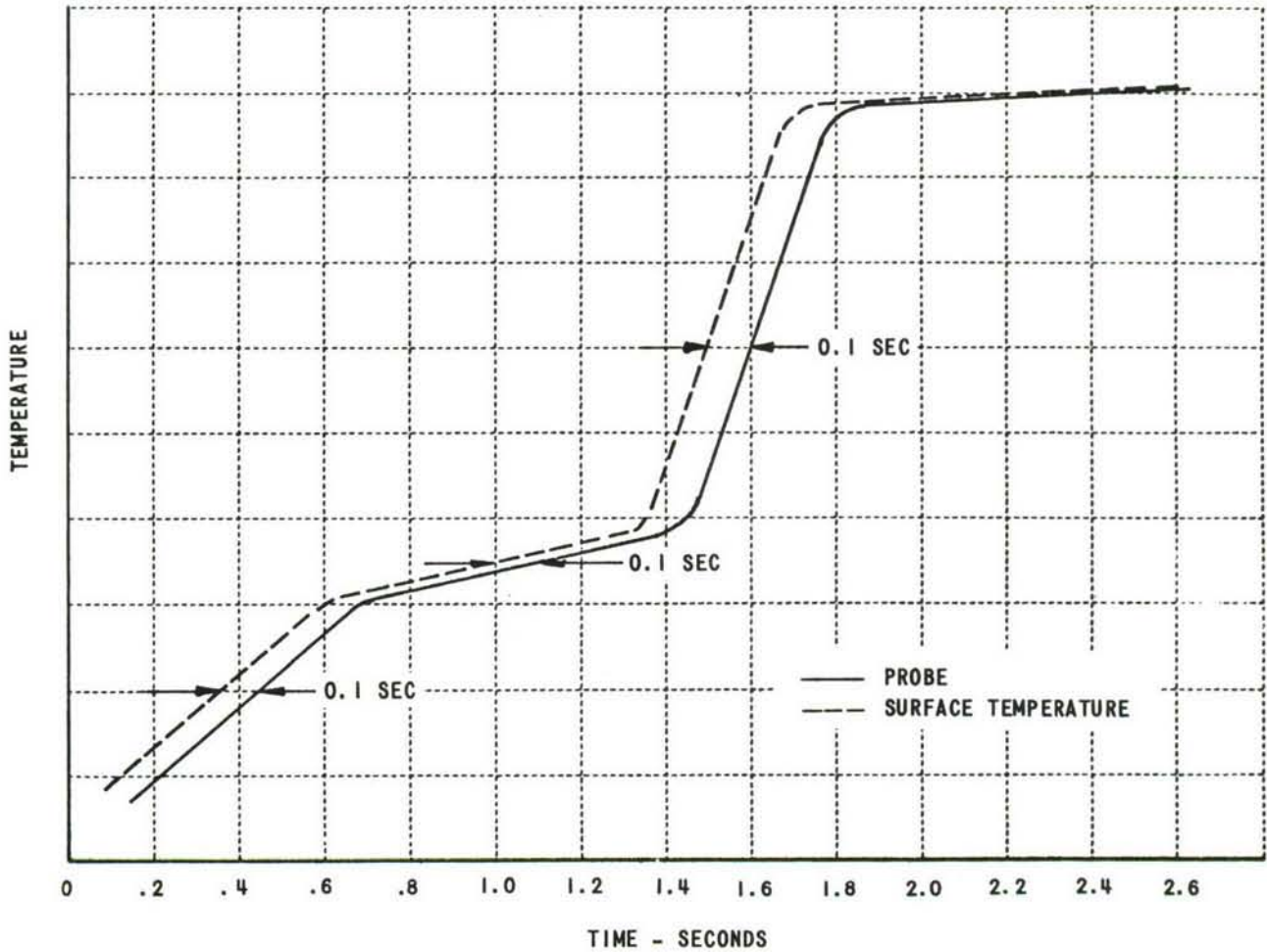

Figure 24 GRAPHICAL CORRECTIONS FOR TIME LAG

in the vertical position in order that some conditions of natural convection could be increased. The results of such tests on stainless steel, aluminum and hot rolled steel, are shown in Figure 25. Here it can be seen that the apparent accuracy of the probe readings is as good as that for the horizontal orientation.

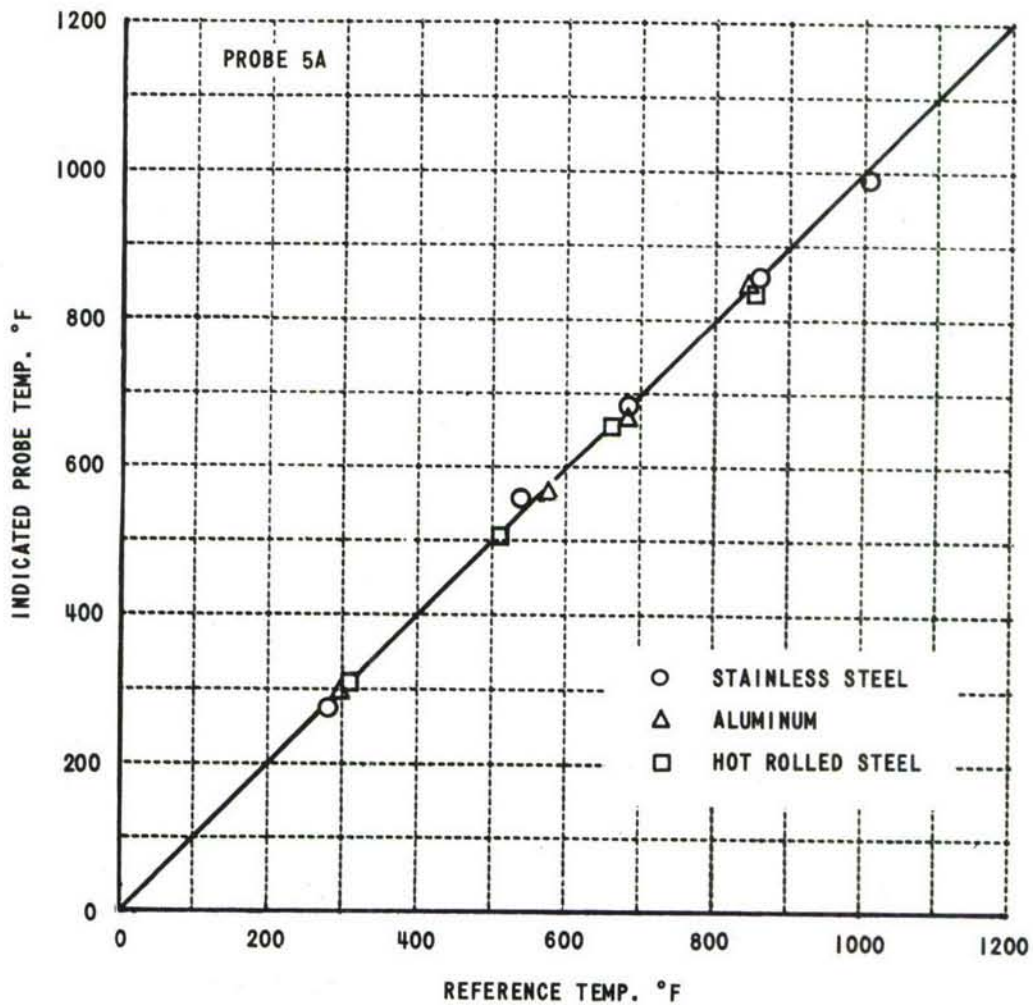

Figure 25 PROBE OPERATED AGAINST VERTICAL PLATE

Further, examination of the data in comparison with horizontal plate data did reveal a consistent, though small, lowering of the indicated temperature data when the plate was vertical. This can be seen in Figures 26, 27, and 28, below. Note that in each instance, a slightly negative deviation was detected and that the maximum spread was found using stainless steel.

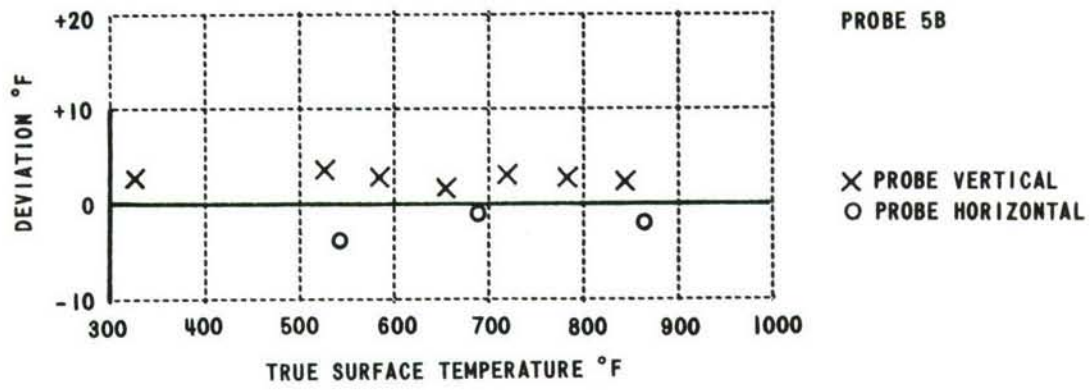

Figure 26 ORIENTATION TESTS ON STAINLESS STEEL

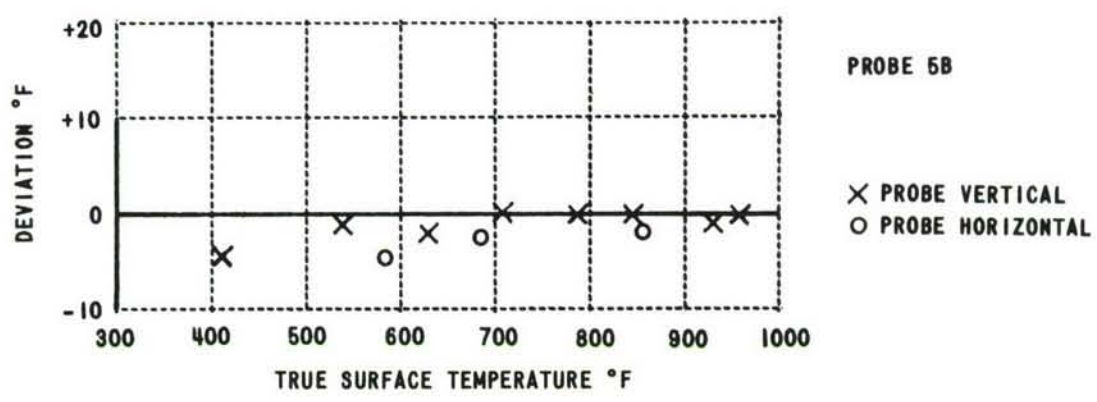

Figure 27 ORIENTATION TESTS ON ALUMINUM

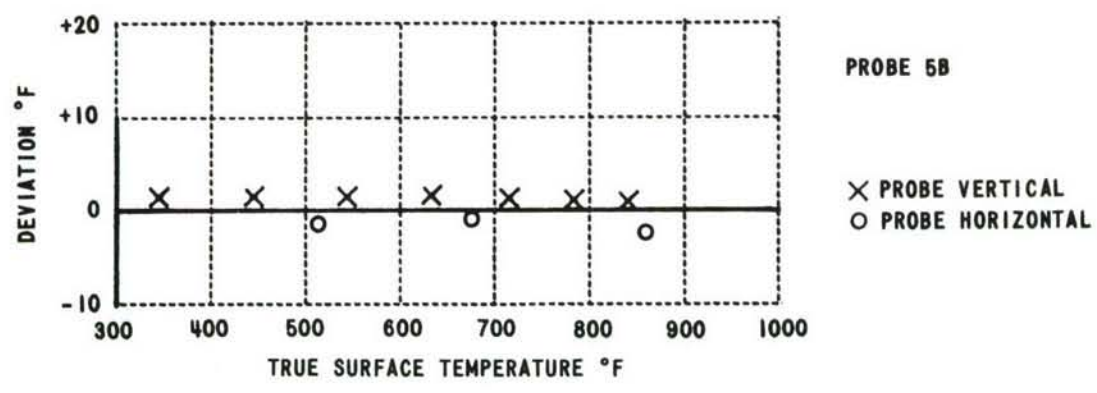

Figure 28 ORIENTATION TESTS ON HOT ROLLED STEEL

Because of this observation, tests were repeated on 0.020" thick stainless steel plate with the latest probe. Stainless steel was used because of the possibility of the effect being exaggerated. The results are shown in Figure 29 below.

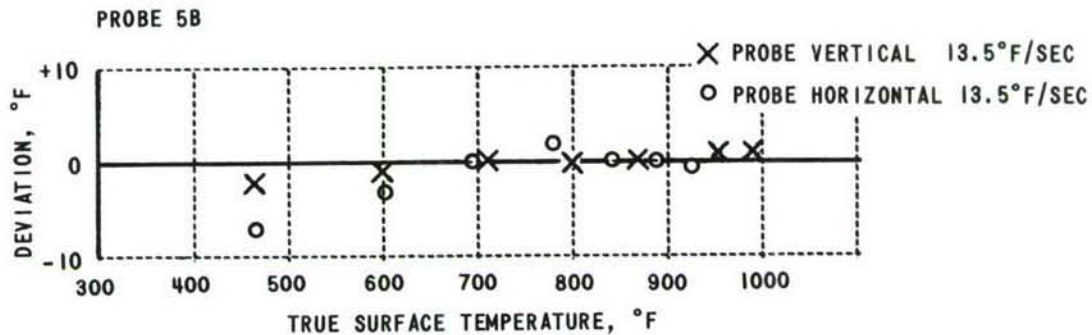

Figure 29 ORIENTATION TESTS ON STAINLESS STEEL

As a result of these tests, it is concluded that an orientation effect is not significant.

5. Shadowing

In order to have a probe produce good accuracy under a condition of radiation heating, it was concluded that it should be a very thin probe so that the effects of shadowing would be minimized. During the many tests that were made to determine the accuracy of the probe, essentially no effect of shadowing was noted. Lack of shadowing is attributed to the fact that the probe at its greatest thickness is only 3/16 of an inch in diameter and, at its point of contact, is much less than 0.045 inches in diameter. In spite of the initial experimental evidence, however, very careful tests were made on stainless steel, hot rolled steel, aluminum and a plastic laminate. No significant effects were detected on aluminum or on hot rolled steel. A very small effect, considered to be negligible, was found on stainless steel. This is reported in Figure 30. Here it can be seen, under the worst conditions for exaggerating the shadowing effect such as an extremely high temperature with a very low thermal conductivity material, that the surface temperature after contact on stainless steel was lowered from 920°F to 917°F after ten seconds. In the next ten seconds it returned to its original level. This is an error of less than a third of a percent of the temperature designated by the reference thermocouple. As the reference temperature is lowered, the probe of course followed it, maintaining a deviation of about +1°F during the test period.

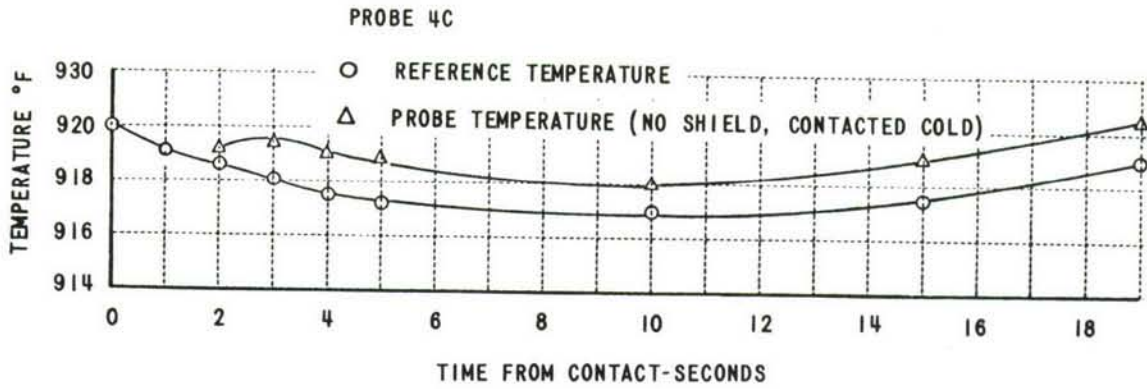

Figure 30 EFFECT OF SHADOWING ON STAINLESS STEEL

This type of test was also performed on the CTL resin - Fiberglass combination because of its low thermal conductivity and probable susceptibility to shadowing effects. Some results are shown in Figure 31 below. This information shows rather minor effects as can be seen by the exaggerated vertical scale.

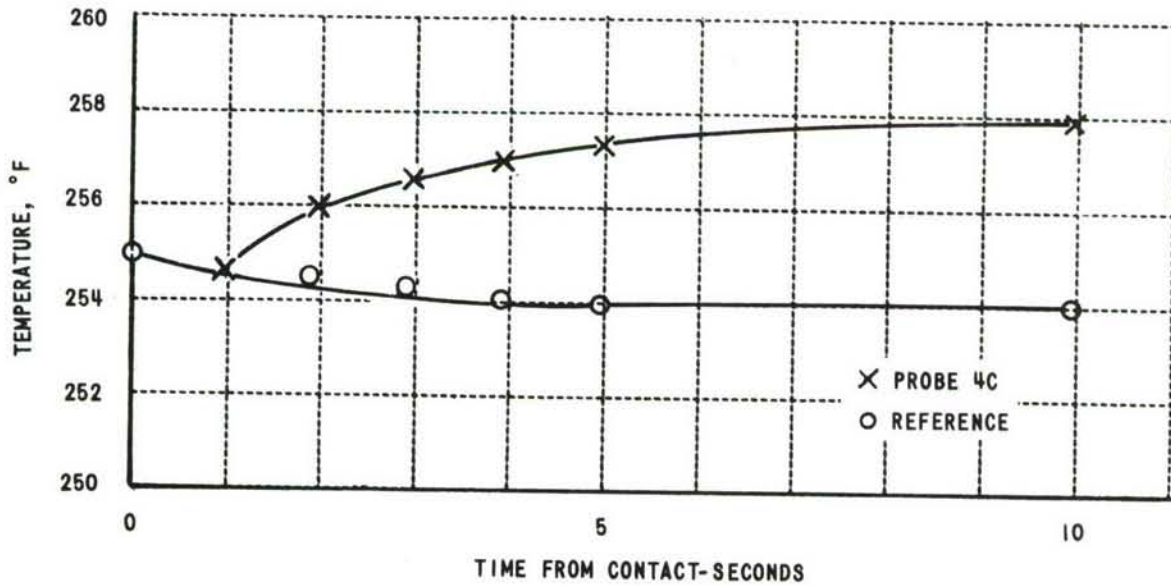

Figure 31 SHADOWING EFFECTS ON PLASTICS

IV. COMPARISON OF PROBE AND SURFACE THERMOCOUPLE PERFORMANCE

In developing a probe for the specialized purpose of operating on surfaces being heated by radiation discussed earlier in this report, it is quite advantageous to know the comparative performance not only of the probe with reference to true surface temperatures as has been discussed in Part I, but also the probe performance with relation to standard means of attaching surface thermocouples. In order to determine the performance for making such a comparison, a number of experiments were completed using a variety of materials, configurations and heat flow condition temperatures. From this series of experiments considerable insight was gained not only in the operation of the probe itself but in relation to the parameters which affect the standard surface thermocouple installation. All of these items are discussed in the paragraphs which follow. Over-all conclusions are summarized below.

1. Conclusions

1. Probe performance is generally as good as or better than permanent surface thermocouple installations.
2. 24-28 gage chromel-alumel thermocouples are appreciably affected by a heating rate of $10^{\circ}\text{F}/\text{sec}$ when attached to stainless-steel. Lower rates produce less error. Under these conditions, probe performance is appreciably better.
3. Error in the standard thermocouple installation is decreased as the size of the wire is decreased. Performance of the probe is comparable to the results obtained with the finest wire tested (36 gage).
4. Use of iron - constantan wire has produced greater error than either chromel-alumel or chromel-constantan.
5. With surface thermocouples, changes in orientation of the test plate and leads produced significant changes in the deviation of the thermocouple reading from the true temperature. The probe readings are essentially not influenced by orientation.

2. Test Configurations

For these comparison tests, all thermocouples were attached in accord with the dimensions and configuration shown in Figure 32 on the next page.

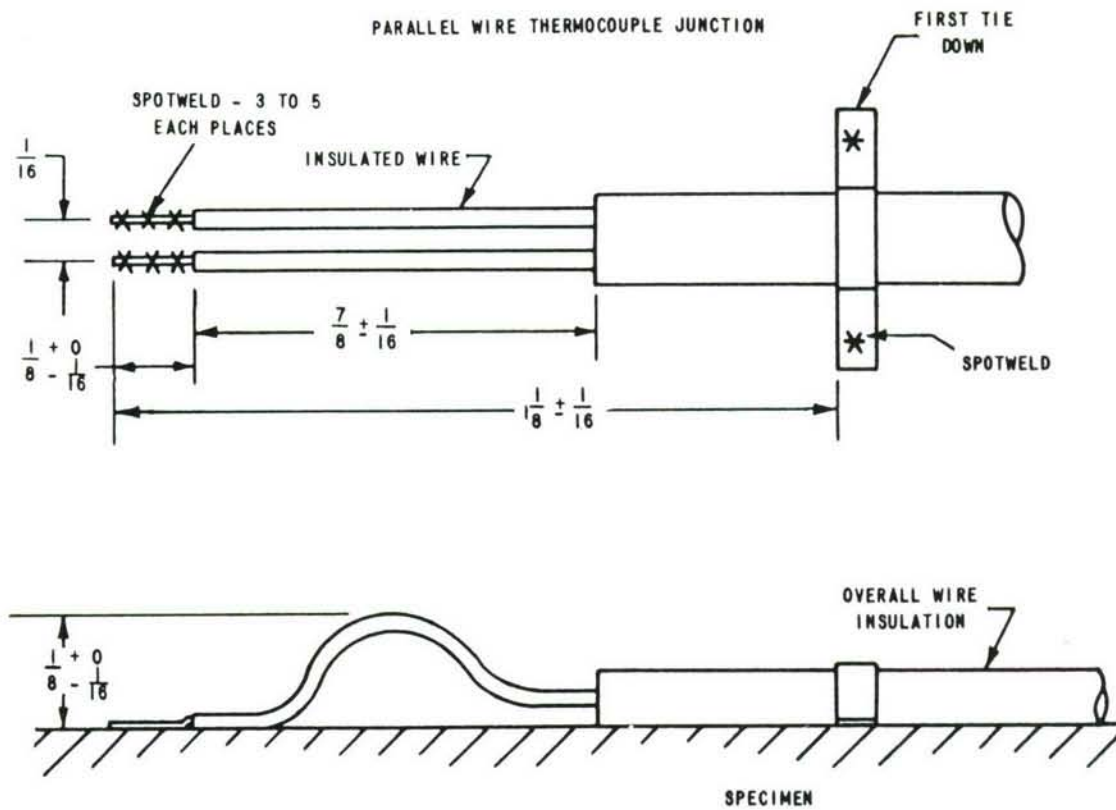

Figure 32 SURFACE THERMOCOUPLE INSTALLATION

A number of different thermocouple wires were used. These are given in the Table on the following page.

<u>Metal</u>	<u>Gage</u>	<u>Type</u>	<u>Calibration</u>	<u>Insulation</u>	<u>Remarks</u>
Chromel	24			Fiberglas	RTD supplied
Alumel	28			Fiberglas	
Iron	24			Thermoplastic	RTD supplied
Constantan	24			Thermoplastic	
Chromel	30	GC-30-C1	IASK	Fiberglas	Thermoelectric duplex
Alumel	30				
Chromel	36	T-36-CTP	ISAKP	Teflon	Thermoelectric
Alumel	36	T-36-CTN	ISAKN	Teflon	
Iron	36	T-40-ATP	ISAJP	Teflon	
Constantan	36	T-40-DTN	ISATN	Teflon	
Chromel	40	T-40-CTP	ISAKP	Teflon	
Alumel	40	T-40-CTN	ISAKN	Teflon	

3. Effect of Heating Rate

The effect of rate of heating can be exceedingly important in the operation of the probe and in the operation of the standard method of attachment of the surface thermocouples. As discussed in previous sections, the response of the probe is rapid, having a time constant of about 0.1 seconds. At a maximum rise rate of 150°F per sec, the deviation in the recorded temperature is about 15°F. This is correctible, however, so that the absolute error, because of time response is almost negligible. Under the usual heating rate, of about 10°F/sec experienced in the test configuration for most of the experiments discussed herein, this deviation is diminished until it is usually no more than 1°F and is essentially negligible in most experiments. Using the standard installation technique (Figure 32) and 24-28 gage chromel-alumel wire, appreciable error can be found in the thermocouples at a heating rate of 10°F per sec. Under these conditions, deviation is as shown in Figure 33 on the following page. Note that, when the rate of heating is lowered to 2.7°F per sec, the accuracy of the thermocouple is much improved. For comparison, measurements by the probe are shown at the higher rate. Note that the performance of the probe is appreciably better than the standard surface thermocouple installation.

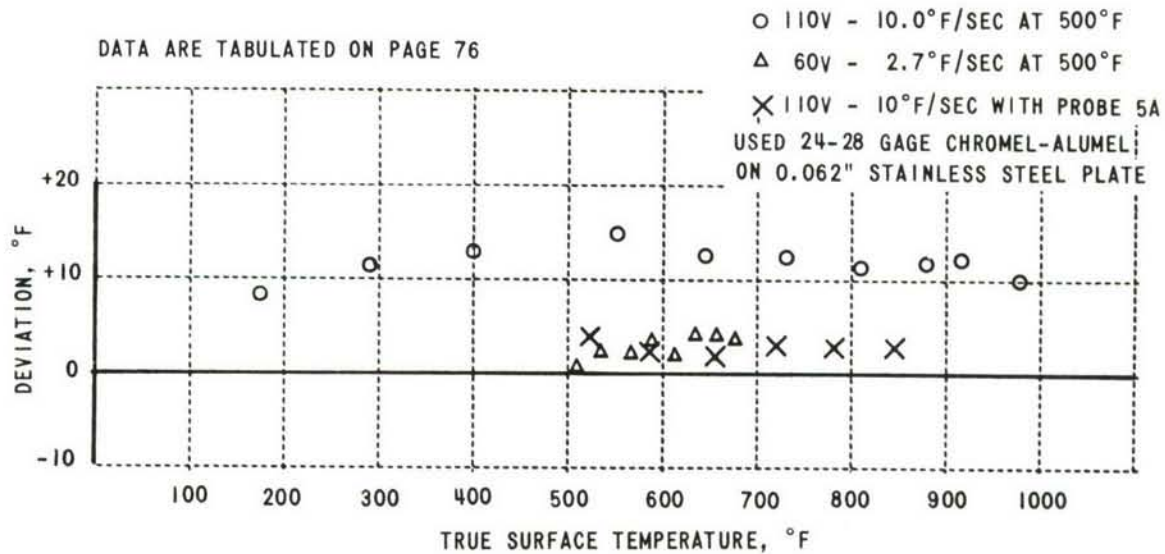

Figure 33 EFFECT OF RATE OF HEATING

4. The Effect of Wire Size

During the comparison runs between the probe and standard installations, it was apparent that the size of the wire influenced the extent of deviation from true surface temperature and that a change in size would improve the results. Therefore, tests were run comparing 24-28, 30 and 36 gage chromel-alumel. The results using a constant heating rate of approximately 10°F per sec are shown in Figure 34 on the following page, which gives the deviation in degrees Fahrenheit versus true surface temperature. Note that the largest wire size has the largest error. As a matter of fact, the average deviation is more than a percent of full range even at the highest temperatures showing a minimum deviation of 10°F. When 30 gage wire is used, some appreciable improvement is noted and an additional improvement is noted when 36 gage wire is used. Because the wires themselves are not large enough to change the heat capacity of the over-all plate appreciably, it seems possible that some effect may be attributed to the increased area for absorption of radiant energy which is caused by the large gage wire. This very probably is exaggerated by the low thermal conductivity of the stainless steel which would tend to be slow in transmitting heat absorbed by radiation in the thermocouple wires through the plate. At the same heating rate, the surface temperature probe performs in a manner comparable to the best results obtained from the 36 gage wire.

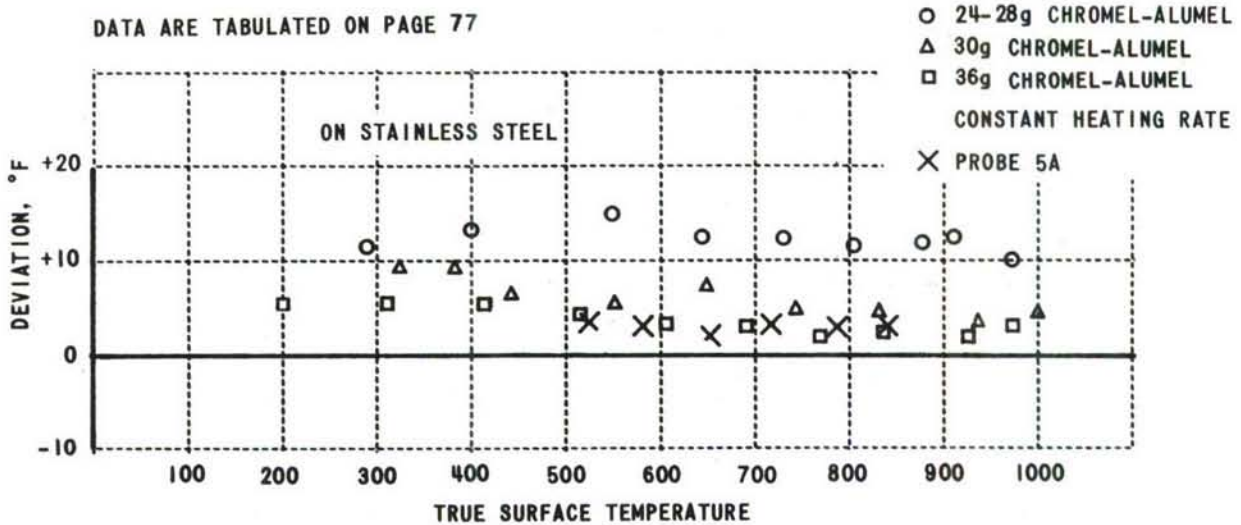

Figure 34 EFFECT OF WIRE SIZE

5. Effect on Various Materials

A variety of materials, on which different thermocouples were mounted, were tested in the horizontal position with the radiation test equipment previously described. Thermocouples were installed as illustrated in Figure 32 on page 34. Their effect on various plates including stainless steel, titanium, magnesium and aluminum are discussed individually below.

a. Aluminum

Three different combinations of 36 gage thermocouples were tried on aluminum in the conventional horizontal test position. These were chromel-alumel, iron-constantan, and chromel-constantan. The results of these tests in transient heating at a rate of approximately 7.0°F are illustrated in Figure 35 on the next page. The performance of the chromel-alumel and chromel-constantan thermocouples was very similar with the chromel-constantan being more accurate in a low temperature range and the chromel-alumel more accurate in the high temperature range. The iron-constantan thermocouples tended to deviate rapidly as the higher temperatures are approached. As a matter of fact, a deviation over $+19^{\circ}\text{F}$ was reached at about 840°F true surface temperature. It seems apparent that there may be a selective absorption of radiant energy by the iron-constantan thermocouple which creates the apparent error. Therefore, it is recommended that iron-constantan thermocouples not be used for surface thermocouple applications under radiant heating.

DATA ARE TABULATED ON PAGE 78

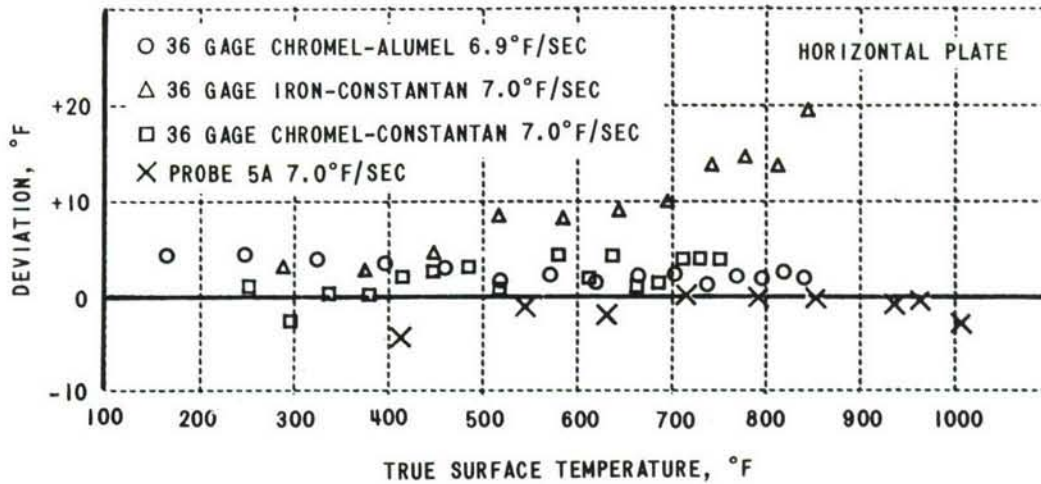

Figure 35 PERFORMANCE OF VARIOUS 36 GAGE THERMOCOUPLES ON ALUMINUM

The x's on the Figure show the performance of the surface temperature measuring probe at a like rate of rise. Note that the performance of the probe is relatively good.

b. Stainless Steel

The results of tests of 24 gage iron-constantan and 24-28 gage chromel-alumel supplied by ASD on 0.062" thick 316 stainless steel plate are shown in Figure 36 below. Two heating rates are shown for each type of thermocouple.

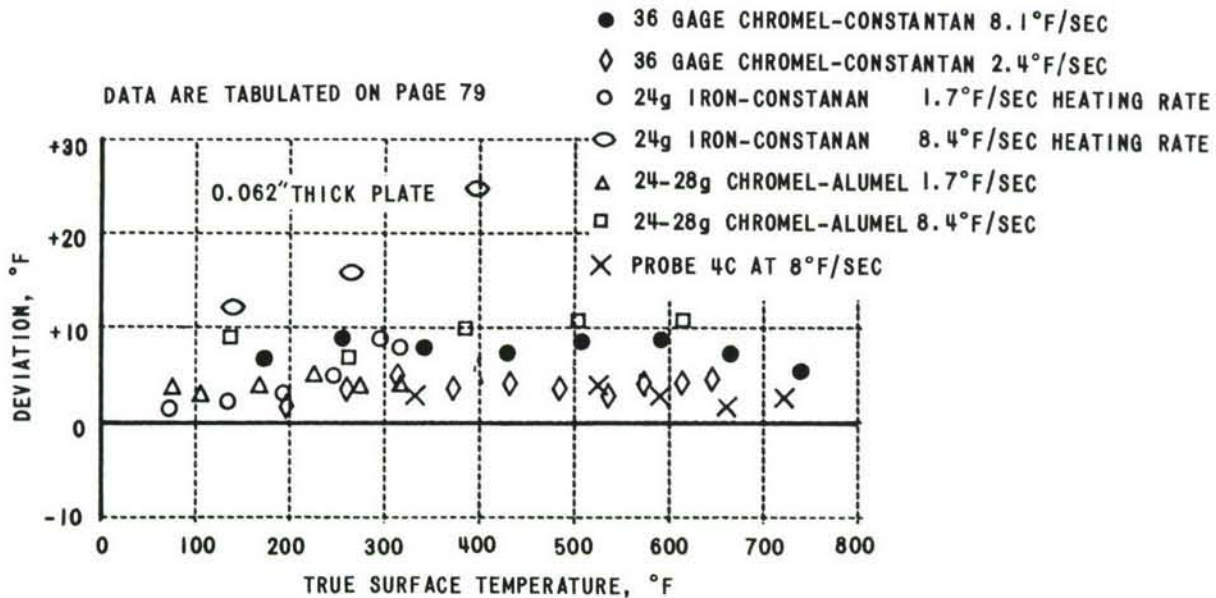

Figure 36 COMPARATIVE TESTS ON STAINLESS STEEL

The results using iron-constantan show excessive error at the high heating rate of $8.4^{\circ}\text{F}/\text{sec}$ with a maximum deviation of $+25^{\circ}\text{F}$ at 395°F . Performance at the lower heating rate ($1.7^{\circ}\text{F}/\text{sec}$) was appreciably better. Unfortunately, higher temperatures could not be used with the iron-constantan because of temperature limitations of the insulation.

Performance of 36 gage chromel-constantan thermocouples was also tested and is included in Figure 36. Note that even though fine wire was used, the average deviation was still as high as $+8.4^{\circ}\text{F}$ at a heating rate of $8.1^{\circ}\text{F}/\text{sec}$. At the lower heating rate, the average deviation was almost $+4^{\circ}\text{F}$. In steady state, a deviation of $+7.0^{\circ}\text{F}$ at 862.5°F and $+1.0^{\circ}\text{F}$ at 519.0°F was recorded.

Performance of chromel-alumel, when compared with iron-constantan, was much better. The maximum error was $+11^{\circ}\text{F}$ at the higher rate. Much improved measurements were obtained at the lower heating rate.

Performance of the probe is also illustrated on the graph. Note that its error at the high heating rate compares favorably with the best runs of the permanent installations even at the low rate.

In order to obtain a higher rate of rise, a $0.020''$ thick stainless steel plate was also used. In these tests the performance of the permanent installation was much improved over the results from the thicker plate. This is shown in Figure 37 below. Because the values were so different, the tests were repeated with the like results. Therefore, it appears that the thickness of the heated surface is important. This is shown by the improvement in iron-constantan performance when a thinner plate was used at similar heating rates.

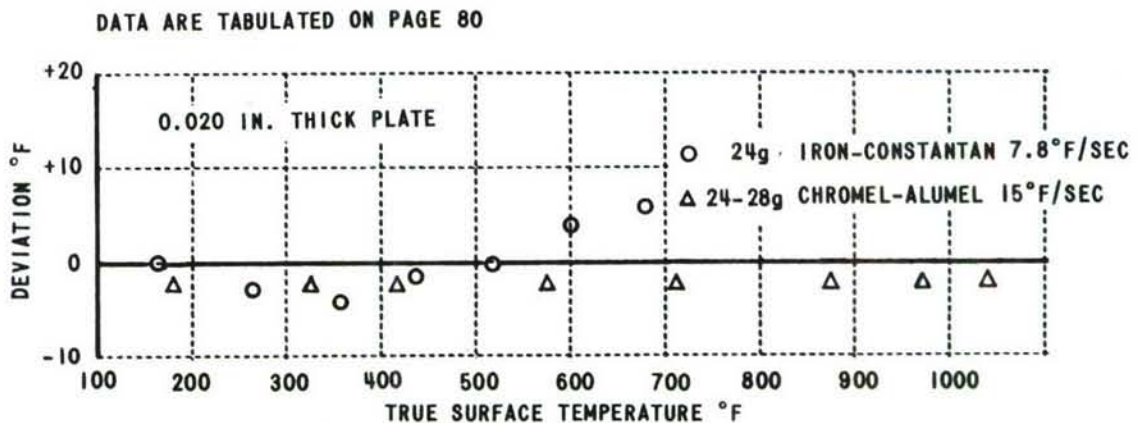

Figure 37 TESTS ON STAINLESS STEEL

Steady state tests were also run with good results. They are given in the following Table:

24 Gage Iron-Constantan		24-28 Gage Chromel-Alumel	
Temperature °F	Deviation °F	Temperature °F	Deviation °F
671.6	-1.6	978.3	-2.3
667.5	-0.2	855.0	-3.0
501.5	-3.5	858.5	-2.5
355.5	-4.9	722.3	-3.8
		725.0	-2.7
221.5	-5.2	377.5	-1.5
		378.0	-1.5
224.0	-5.4	244.0	-1.0
		244.0	-0.5

In order to obtain a higher temperature rise rate, a 0.005" thick stainless steel plate was heated in the normal radiant heating manner. Chromel-alumel thermocouples (36 gage) were used because of difficulty in attaching heavier wire. The results are shown in Figure 38 below. Note the very good agreement between the plate temperature and the permanently installed thermocouples. Under similar conditions, considerable lag is found in the probe system (approximately 20°F), but this indicated temperature lag is made negligible by techniques explained under response time performance.

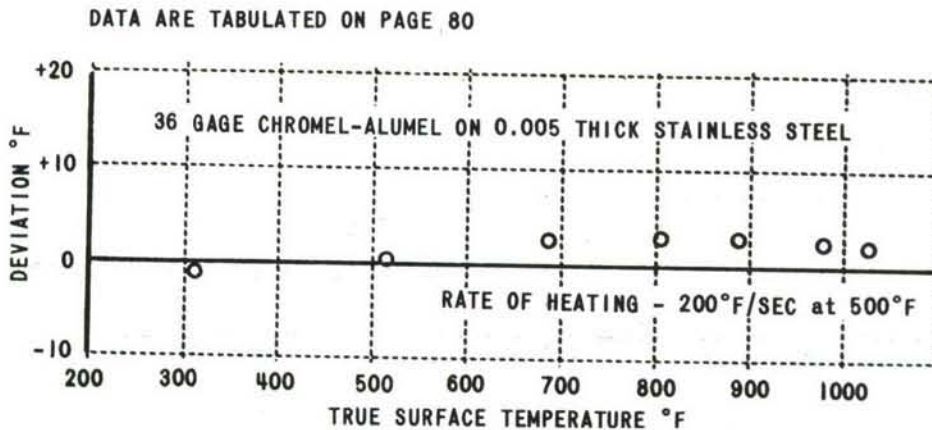

Figure 38 TRANSIENT TEST ON STAINLESS STEEL

c. Titanium

Test were made using a 0.050" thick titanium plate in order to compare iron-constantan and chromel-alumel thermocouples with the probe. The results of these tests are shown in Figure 39. The two types of thermocouples performed in a comparable manner. At the higher temperatures, the chromel-alumel thermocouples stabilized at an average error of almost 10°F at a heating rate of 13.3°F/sec. The spread of data when the probe was used was similar to that of the thermocouples, but the probe measurements were better because their average deviation was only -2.1°F.

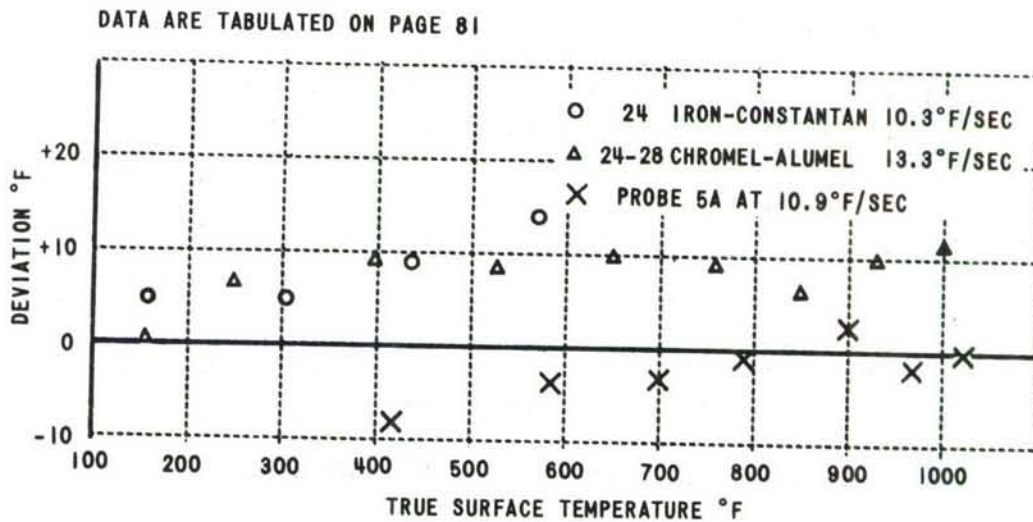

Figure 39 COMPARATIVE TESTS ON TITANIUM

The steady state performance can be observed in the Table below. The accuracy of the results is very good. These results compare with steady state tests of the probe which ranged from +5.0°F to 6.5°F at 835°F. Here the spread of the two systems was about equal but the probe deviation was greater.

24 Gage Iron-Constantan Temperature °F	Deviation °F	24-28 Gage Chromel-Alumel Temperature °F	Deviation °F
547.5	0	922.5	2.5
549.6	0.9	925.0	2.0
333.5	-2.5	886.6	0.4
333.5	-3.5	887.0	1.0
		755.5	0
		615.3	-0.3
		616.0	1.0
		466.0	0.6
		466.3	0.7
		312.5	0

d. Magnesium

The results of comparative tests on magnesium showed rather good agreement. When chromel-alumel thermocouples were used at a heating rate of 16.4°F/sec, the maximum deviation was -5.0°F at about 800°F. This is shown in Figure 40 below. The performance of the probe, in comparison, is similar. The probe does have a slightly greater data spread (6.9°F) but the average deviation is comparable (-2.9°F).

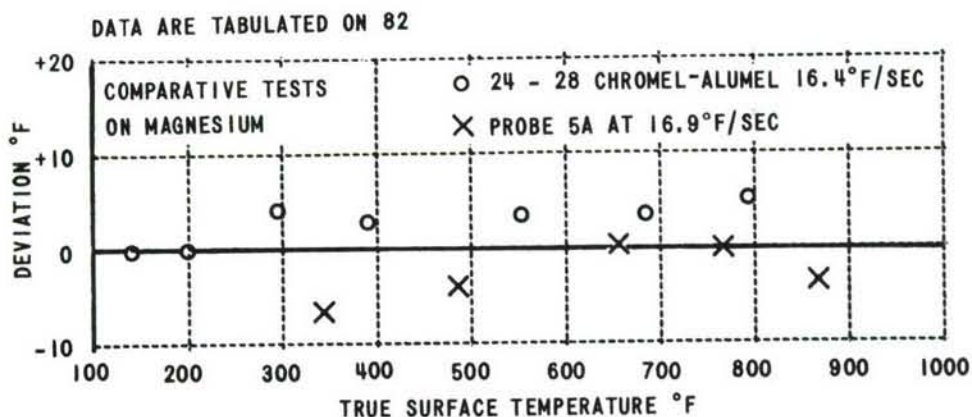

Figure 40 COMPARATIVE TESTS ON MAGNESIUM

In steady state operation, the results of chromel-alumel thermocouples on magnesium was very good. This is demonstrated in the table below.

CHROMEL-ALUMEL THERMOCOUPLES

<u>Temperature °F</u>	<u>Deviation °F</u>	<u>Temperature °F</u>	<u>Deviation °F</u>
837.0	2.6	629.0	1.0
838.5	2.0	445.0	0.0
840.0	2.6	443.6	0.0
628.0	0.6	297.6	0.4
628.6	0.9	298.5	0.5

Probe results gave a maximum deviation of 4.5° with an average deviation of 3.1°. The total spread was 4.5°F.

e. Non-Metals

Tests on plastics were made by applying 36 gage chromel-alumel thermocouples to the surface of a CTL-Fiberglas laminate and subjecting it to radiation heating in the standard test apparatus. The thermocouples were applied to the surface in accord with the configuration used on all other attached thermocouples with the exception that the tips of the wires were brought together in a V and welded. The wires were bonded to the surface at the junction and other attachment locations using SC12* cold setting silver micro paint. The method was quite workable with 36 gage wire and the paint is useful to the limits of the laminates thermal degradation. The results are shown in Figure 41 below. Note that the results were higher than the true surface temperature with a maximum spread of 7.4° and an average deviation of +6°F.

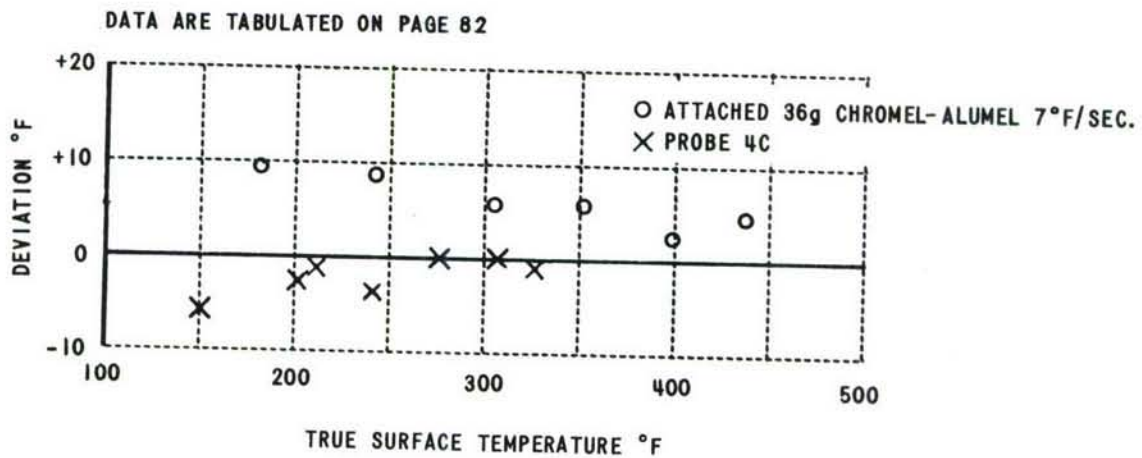

Figure 41 COMPARATIVE TESTS ON PLASTICS

For comparison purposes, probe data are also included on the graph. In this case, the maximum spread was 5.5° with the average deviation being -2.1°F. Tests were also made on a 0.040" thick lava plate. Thermocouples were attached just as they were on plastics except that Sauereisen** Insulate Cement #1 paste was used as an adhesive. Because of the very low thermal conductivity of the lava, considerable discrepancies existed between the reference

* Supplied by Micro-Circuits Company, New Buffalo, Michigan; also see Appendix C.

** Sauereisen Cements Company, Pittsburgh, Pa., also see Appendix C.

thermocouples and surface thermocouples exposed to radiant energy during transient heating. Because calculated corrections between the two thermocouples were so large only the steady state data can be considered to be reliable. In these steady state tests, at 471.5°F, the deviation varied from -0.9°F to +3.5°F and, at 805.0°F, the deviation varied from +2.5° to +6.6°F. The performance of the probe under similar conditions varied from comparable to slightly better than surface thermocouples.

6. The Effect of Orientation

A number of experiments have been run to evaluate the effect of orientation on the surface temperature probe and on the standard permanent thermocouple installation on the surface. Tests, showing the effects of both the probe and a number of thermocouples, have been previously described under Aluminum and have shown that fine wire thermocouples composed of either chromel-alumel or iron-constantan perform acceptably with the plate in the horizontal position. As an additional reference point, in the graph below, examples of both vertical and horizontal plate performance is given for permanently installed wires. Note that the performance of chromel-constantan thermocouples when installed on a vertical plate with the leads up and with the leads horizontal are comparable in performance to the plate in the horizontal position.

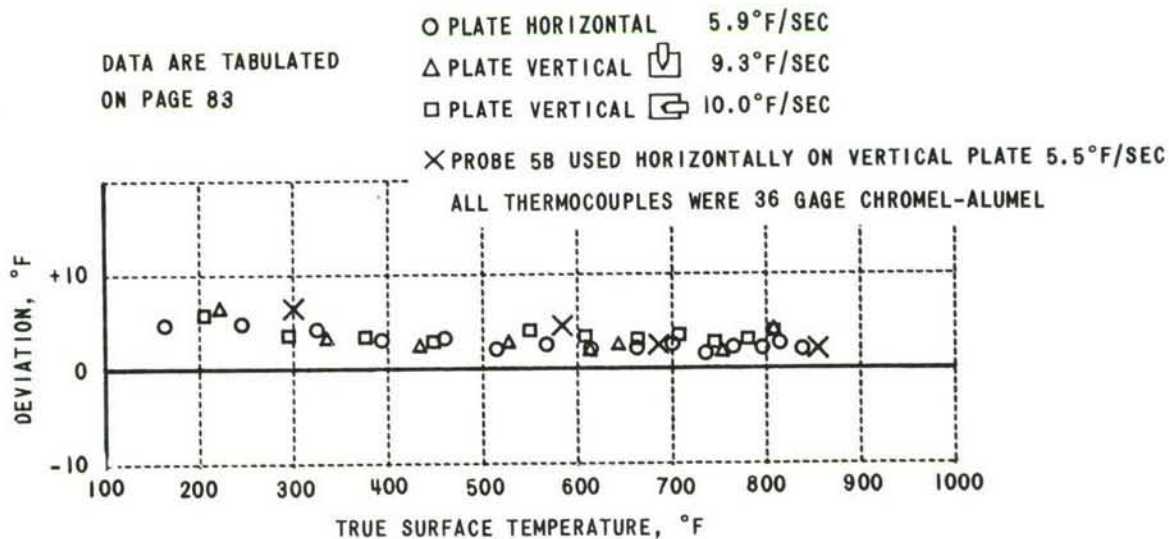

Figure 42 EFFECT OF ORIENTATION ON ALUMINUM

The x's on the curve illustrate the performance of the probe when used horizontally on a vertical plate. Note that its performance also is comparable.

If heavier wires are used, the results can be somewhat different. This situation has already been discussed under the effect of Wire Size on page 36. For additional evidence, 24-28 gage chromel-alumel thermocouples were tested on a vertical plate in three different orientations, with the leads up, with the leads down, and with the leads horizontal. Note in Figure 43, that the maximum error, which is quite appreciable, occurs when the leads are led horizontally from a vertical plate. Next, in order of accuracy, is leads up from the vertical plate. Finally, and most accurate, is leads downward from the vertical plate.

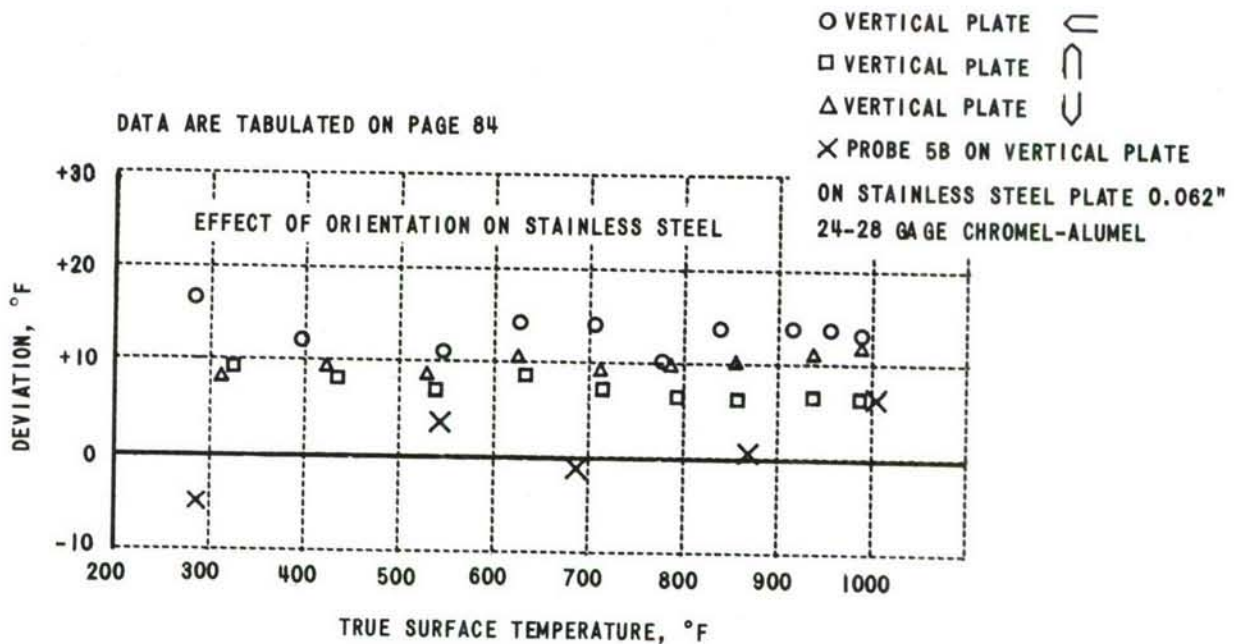

Figure 43 EFFECT OF ORIENTATION ON STAINLESS STEEL

For comparison purposes, data of the performance of the probe operating horizontally on a vertical plate are also given. Notice that its accuracy in following comparable transients is somewhat better than any of the thermocouple configurations.

V. A 3000°F SURFACE TEMPERATURE MEASURING PROBE

The probe system has been operated satisfactorily in intermittent use on surfaces above 1800°F. Although no attempt has been made to determine its longevity in continuous or intermittent use, it is believed that with very minor modifications it can be made to be quite reliable in temperatures of the order of 1800°F to 2000°F. As the effort is made to extend the useful continuous operating range to 3000°F, the problems that need to be solved increase in magnitude quite considerably. An investigation has been conducted to determine the design of a probe patterned after the present lower temperature probe which will perform the same function in a temperature range extending from 1000°F to 3000°F with an accuracy of 1/2%. The results are encouraging in that the present probe system appears to be adaptable to the upper range without any basic modification in configuration. Secondly, although there are materials problems, each of them appears to be solvable. The development is now at a stage where construction of a 3000°F probe can be started. Some relatively minor auxiliary work needs to be done in order to solve some of the more marginal problems. Each of the areas of the system design are discussed individually below.

1. The Sensor

Because the sensor is the only part of the system actually exposed to the 3000°F temperature, it is obviously the most critical problem in the design. Essentially all of the key materials used in the present 1000°F probe must be replaced with other higher temperature materials. For example, the probe support or sting will be changed to 99% pure alumina. This material can be obtained in the form required for supporting the sensor and with appropriate ducts for the lead wires. Machining of the tip to get the appropriate shape for diminishing conduction away from the sensor will be more difficult.

The ceramic spacer between the sensor thermocouples can also be made of pure alumina so that it is expected that a problem of support will be solved.

Obviously the chromel-alumel thermocouples presently used will not be useful because of the high temperature exposure of the new sensor. Even platinum-platinum rhodium may not be used because of its marginal reliability at 3000°F. Further, its emf output seems too low to be able to permit the system to perform as the 1000°F probe now performs. The thermocouple possibilities are listed in the curves in Figure 44 on the following page. Data on other possibilities will be forthcoming, but none are known to be clearly better for this purpose than those illustrated.

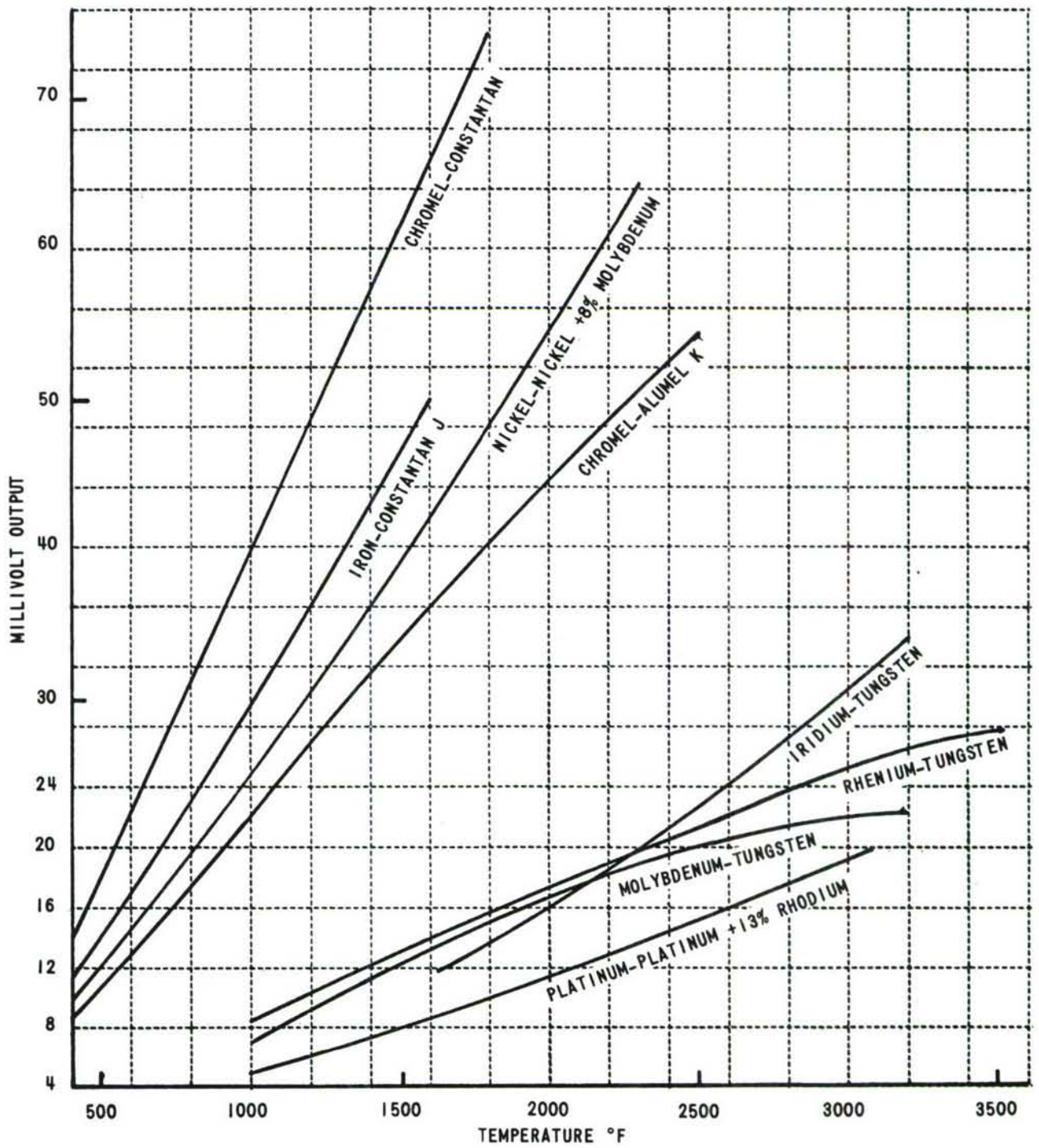

Figure 44 OUTPUT OF VARIOUS THERMOCOUPLES

Several qualities are important in the thermocouples to be used for this application. Of course, the need for high temperature operation immediately eliminates some which otherwise would be most acceptable. Of those which will be able to withstand the temperature, it is desirable to have a high emf output in the temperature range involved and, secondly, it is important to have a high change in the emf per degree. Also desirable, of course, is linear emf output with temperature change over the range involved. From the curves, it is obvious that two types of thermocouples appear to be in contention. One of these is rhenium-tungsten and the other is iridium-tungsten. From the standpoint of over-all emf output, rhenium-tungsten seems to have the advantage in the range from 1000°F to about 2200°F while iridium-tungsten has the advantage above this temperature. It is believed, however, that the greater output per degree of change of iridium-tungsten makes it more desirable. For the first prototype high temperature probe, therefore, iridium-tungsten is chosen as the type of thermocouple element to use. The advantage it has with reference to emf output per degree is easily seen by the Table below which illustrates the relative comparison between chromel-alumel and other common thermocouples.

Chromel-constantan	1.91
Iron-constantan	1.48
Chromel-alumel	1.00
Iridium-tungsten	.578
Platinum-platinum 13% rhodium	.421
Rhenium-tungsten	.37

In the use of these thermocouples, it is important that oxidation deterioration of the thermocouple be avoided. Because tungsten is quite susceptible to oxidation, it will be necessary that a protective coating be applied to the tungsten. A variety of possibilities have been considered such as molybdenum disilicide, rhodium alloys, etc. It is believed that perhaps these or an oxide type coating can be applied. Because the area exposed is so extremely small, the outlook for success from the oxidation protection standpoint is considered to be good.

Another concern is the heater element which must replace the present platinum element. It is expected that the first prototype will be constructed using rhodium alloys which are capable of withstanding over 3500°F. This and other material changes are shown in Figure 45.

A major concern is the ability to attach the heater element to the thermocouple element. In the present situation glass is being used with a positive mica-separator. This must be replaced by a high temperature cement. Experiments are being conducted which are intended to determine the usefulness of a

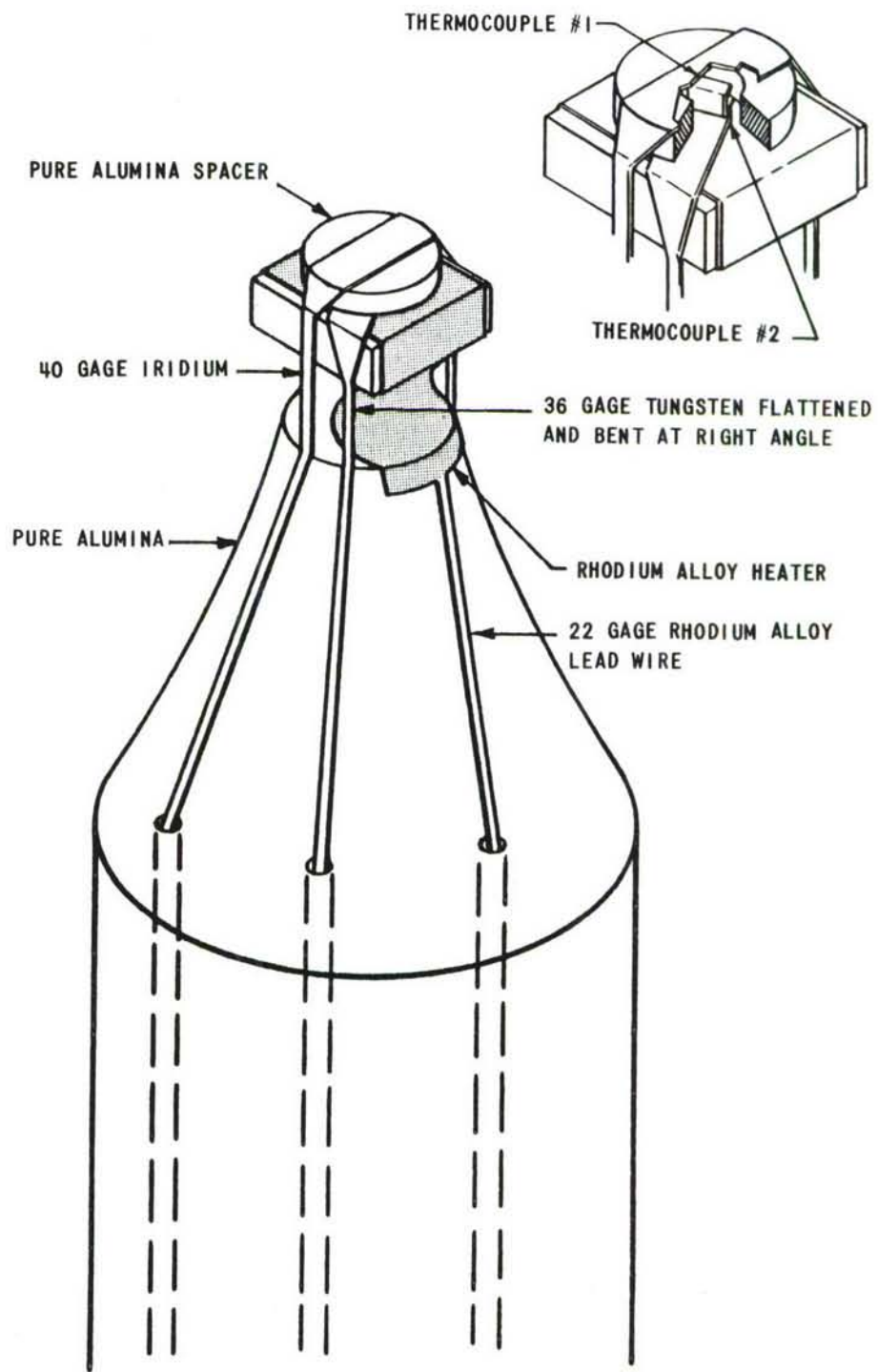

Figure 45 3000°F PROBE SENSOR

number of cements which do not contain silica. Silica is being avoided because of the probability that it will attack the heater or tungsten elements. Because of the very minute size of the instrument, it is expected that success will be achieved although this problem may be the most difficult one which must be solved.

2. The Power Amplifier

It is expected that the present power amplifier will suffice for operation at 3000°F if an increase in heater resistance by two and an increase in DC voltage supply from 6 to 12 can be achieved. There will apparently be no difficulty in making these changes so that the problem is not considered to be serious.

The present power transistor is capable of producing a 90 watt output into the proper load. In view of the fact that the load can be adjusted appropriately, there is considered to be no particular problem. It is believed that the heater resistance increase can be achieved by doubling its length. This can be achieved without increasing the tip size.

VI. BIBLIOGRAPHY

1. Sasaki, Nobuji, "A New Method for Surface Temperature Measurement," Review of Scientific Instruments, Vol. 21, No. 1, January 1950.
2. Lai, W., "Surface Temperature Measurements with Thermoelectric Materials," ASD-TDR-61-373, August 1962.

APPENDIX A DEVELOPMENT OF THE SENSOR

The following paragraphs describe the evolution of the present probe design. This section is included because of the perspective it presents concerning the variety of problems that were encountered. It, therefore, explains why the present design configuration was adopted. For concise details of the present design, see "The Design of the 1000°F System" starting on page 5.

The development of the sensor required an appropriate compromise between the needed performance characteristics of the probe sensor and fabrication difficulties. At the start of the development, it was felt that perhaps the simplest sensor configuration would be that described under The Basic Approach. In it, two thermocouples and a heater flattened to extreme thinness, each insulated from the other, was suggested as a possible configuration to accomplish the performance goals of the sensor. This system, however, would require greater complexity in the power amplifier and read-out circuit in that one of the thermocouples would have to be used part time for control and part time for recording. Such a system would require the use of some type of high-speed switching device. The first probe was patterned to the above design for probe response tests before the controller was available. Some features of this probe (and the one that followed) are shown below:

	<u>Probe 1</u>	<u>Probe 2</u>
Thermocouple material	Iron-constantan	Iron-constantan
Thermocouple beadwidth	0.015"	0.015"
Thermocouple bead thickness	0.0015"	0.0008"
Insulator between thermocouples	Refractory cement	Glass
Gap between thermocouples	0.005"	0.0015"
Nichrome heater	Coil	0.001"-thick strip
Sensor support	Pyrophyllite	Refractory porcelain
Tip radius	3"	0.055"

Results of the tests of the first probe showed it to have a response time that was considerably longer (several seconds) than was desired for the final probe. For this reason some of the changes as noted in the Table above were incorporated in Probe 2 to get a faster response. During the testing of the second probe, however, failure occurred shortly after the beginning of testing because of the deterioration of the heater element and thermocouples during fabrication. It was believed that this occurred because of the numerous firings that the probe required during fabrication and that oxidation of the leads was the basic cause.

The third probe was made using chromel-alumel instead of iron-constantan for the thermocouples and replacing the nichrome with a nickel heater. Tests of the third probe were completed using an electrically heated, calibrated silver block as a temperature standard. This unit was constructed for this purpose and is described in this report. The accuracy of the surface temperature measurement using this probe was found to depend greatly on the contact pressure between the probe and the surface. For example, an order of magnitude reduction in error from 5% to 0.5% at 600°F was produced with the change of loading from about 20 gm to about 100 gm. Further increase of the contact pressure produced little change in error. The response of this probe to a step change in temperature was better than that of previous probes although the time to reach steady state was still much too long for useful application. In an attempt to reduce the response time of the probe, the power capability of the heater was exceeded, causing burnout of the heater element.

As the probe construction evolved, a basic ceramic structure was used with a small strip heater on which was placed two thermocouples bonded by fired coatings of glass. The ceramic was fired lava or refractory porcelain, the heater strip was high purity platinum (about 0.0005" thick), and the thermocouple was 40 gage chromel-alumel wire pressed to about 0.0005" thick. Testing of these probes was again carried out by contacting the probe to the silver, standard-temperature body. The response of the probe was attained from a time history of the temperature difference between the two probe thermocouples. The accuracy was obtained by measurement of the temperature difference between the silver surface and the probe surface thermocouple at the time when the temperature balance had been achieved in the probe. The results of these tests indicated that the temperature error could be reduced to less than one percent with suitable application of power to the platinum guard heater. The error in temperature measurement was found to be nearly independent of the contact pressure (presumably because of better guard heating). On the other hand, the time response of this system was found to depend greatly on the contact pressure and the thermal resistance between the probe and the surface.

At this time, because of the concern over the potential problem of contact pressure, considerable effort was expended in evaluating configurations and their effects. Generally two types of probe-surface thermocouple arrangements were tested, that in which a plain chromel-alumel thermocouple embedded in fired coating was allowed to contact the heated plate, and that in which a small surface disc of platinum was added to the thermocouple junction to increase the contact area. It was found that good response with the plain thermocouple could be obtained only by applying a small amount of metallic wetting agent, namely, solder, to the heated plate and then contacting the probe at this location. This effectively reduces the thermal contact resistance and increases the contact area. The thermocouple and disc arrangement, on the other hand, was shown to perform well without the wetting agent, and it was expected that future probes would utilize this type of construction.

Up to this time in the probe sensor development, performance testing was conducted either without a controller or with an electro-mechanical controller that had been improvised for the purpose. These were then supplanted by a completely electronic controller which is described in detail in this report. The first studies of the combined electronic system-probe sensor was applied to the determination of power requirements. The expected power loss through the surface temperature probe during steady state operation at various temperature levels is shown in Figure 46 for two

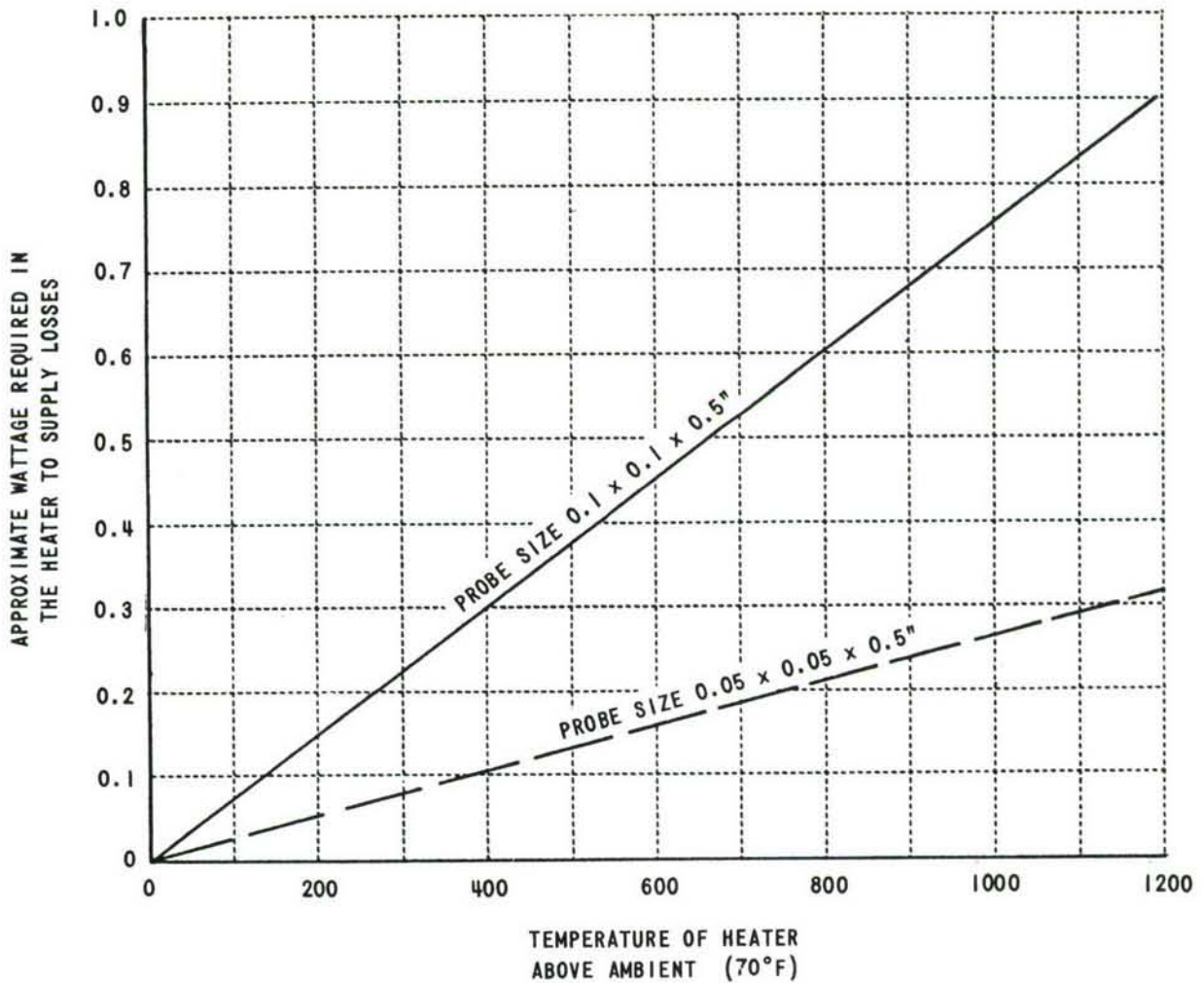

Figure 46 POWER REQUIREMENTS OF HEATER

probe sizes. The test probes up to this time had a 0.1" x 0.1" cross section. The effect of probe sizes was demonstrated by the curve for the 0.05" x 0.05" cross section. For the standard test probe, Figure 46 shows that approximately 0.75 watts was required in the probe heater at a temperature of 1000°F. Correspondingly less power was needed at lower temperatures. The output voltage characteristics of the electronic power controller for various levels of input signal amplification from the probe sensor is shown in Figure 47.

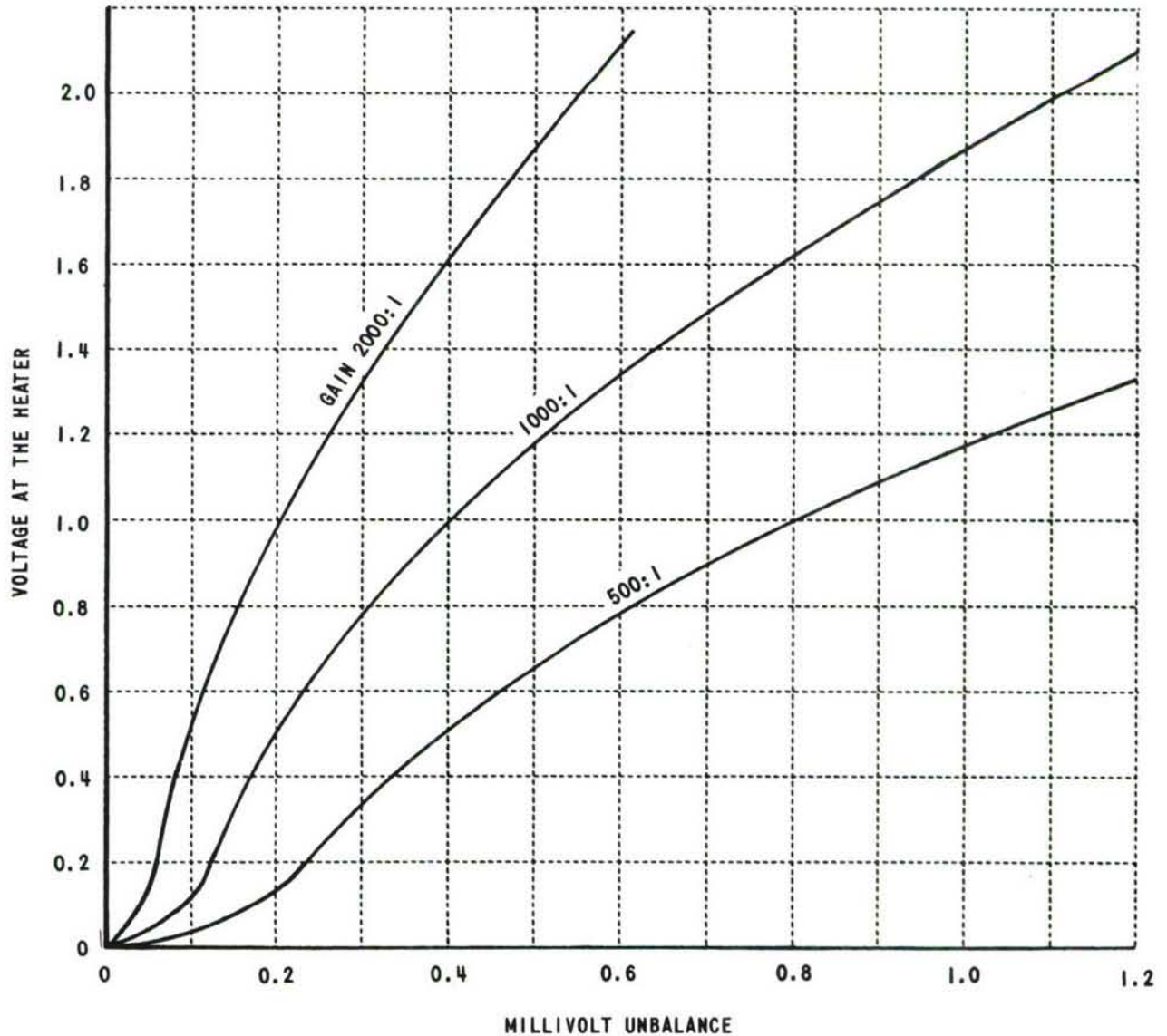

Figure 47 VOLTAGE CHARACTERISTICS OF THE CONTROLLER

Millivoltage values represent the temperature unbalance in the surface temperature probe. By comparing Figures 46 and 47, it is obvious that a small error signal is required (Δ mv) even at steady state operation to supply the required power. The magnitude of the error signal depends on the voltage gain of the amplifier. For example, taking the probe heater elements to have a resistance of nominally 0.06 ohms, the figures indicate error signals at 1000°F of about 0.6, 0.12, and 0.23 mv at gains of 2,000, 1,000 and 500 respectively. Chromel-alumel thermocouples produce about 0.023 mv per degree Fahrenheit. Thus, it is shown that a gain of at least 2000 is needed to maintain 3/8% accuracy at 1000°F for these test probes. With the smaller probe (0.05" x 0.05"), a gain of 1000 was expected to be sufficient.

Experiments were then carried out to determine the rate of temperature rise of the probe heater as a function of the applied power. The results are illustrated in Figure 48. These values indicated the speed with which the probe

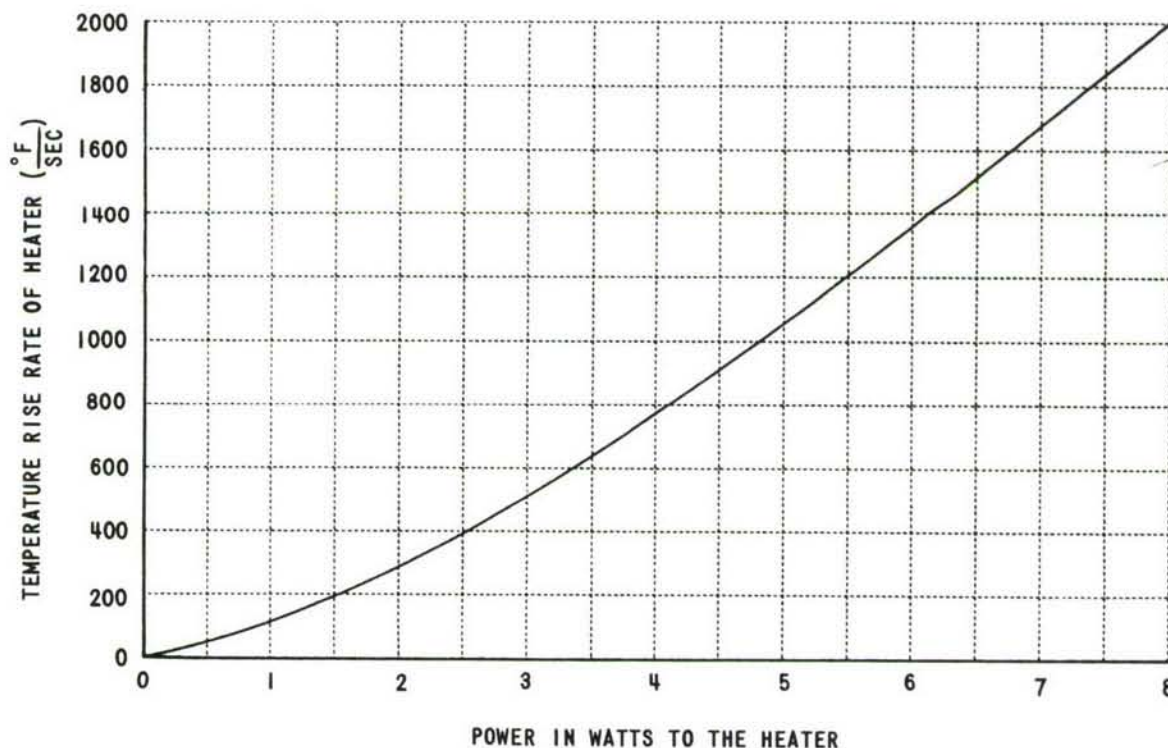

Figure 48 HEATER RESPONSE VS. POWER

heater is capable of returning the probe thermocouple to thermal balance after contact with the heated plate. As an illustration, consider the surface temperature probe in contact with a heated plate and initial unbalance between sensing thermocouples of 50°F at 500°F (10% error). If the controller were turned on at this time and a gain of only 500 were used, temperature balance would be achieved at an average rate corresponding to the average power of $(1.22)^2 / 2(0.06) = 12$ watts. Extrapolating the curve of Figure 48, this amounts to about 3600°F per second. Thus, the approximate time for balance is 50 divided by 3600 or 1.39 milliseconds. In actual application of this probe technique, however, a comparatively long time, (of the order of a second) had been required to produce the original unbalance between the probe temperature sensing thermocouple. It was thus believed that production of the unbalance was the primary detriment in the rapid responsive system, and that the time required to produce temperature correction was very small.

About this time in the development of the sensor, considerable difficulty had arisen due to failure of the 0.0005" platinum strip heater when heating was rapid. The failure was believed to be caused by the inability of the thermocouple sensor at the heater to respond closely enough to change of heater temperature. Because DC is used in the heater, contact of this thermocouple with the heater strip had to be prevented; otherwise, the thermocouple output would have no significance. In the earlier probes, a layer of glass as thick as 0.005" had been used for electrical insulation. It was found that this amount of glass was too great to permit good heat transfer between the thermocouple and the heater. An attempt was made to place an oxidized thermocouple directly on the heater and thus have nearly direct measurement of its temperature. The oxidation process was found to weaken the thermocouple wires greatly, however, so that upon application of a final glass coating by furnace firing, failure of the thermocouple wire frequently resulted. After several attempts with no positive results, this technique was abandoned in favor of more rigorous application of the glass layer between the heater and unoxidized thermocouple wire. Thus, additional effort was expended in maintaining glass layers to thickness of the order of 0.001". This was found to be sufficiently small for rapid response between the heater and thermocouples.

About this time two types of guard heater designs were investigated, namely circular and rectangular platinum strips 0.0005" in thickness. Both were found to operate successfully for control, however, the circular heater had the disadvantage of a large temperature gradient from its center to its edge causing non-uniform heat loss. The rectangular strip heater on the other hand, had nearly uniform temperature from center to edge resulting in somewhat better performance. The prime feature of the circular heater was adaptability to small size, but its development was stopped pending outcome of a total evaluation of the rectangular heater system.

All previous test probes which were used in combination with the electronic controller were made using only two thermocouples. This was deemed adequate for investigating the performance of the control system as well as the expected probe response. For the simplest control-read-out system, operational surface

temperature probes should have a third, or indicating, thermocouple which permits continuous temperature reading. This simplifies the control system and eliminates certain switching operations that would be required if thermocouples were used for both control and read-out. Several test probes with three thermocouples were tested producing the typical results given in the Table below and in Figure 49. As noted from the Table and from Figure 49,

<u>True Surface Temperature °F</u>	<u>Maximum Error of the Probe-%</u>
200	+0.5
300	+1.0
400	+1.4
500	+1.3

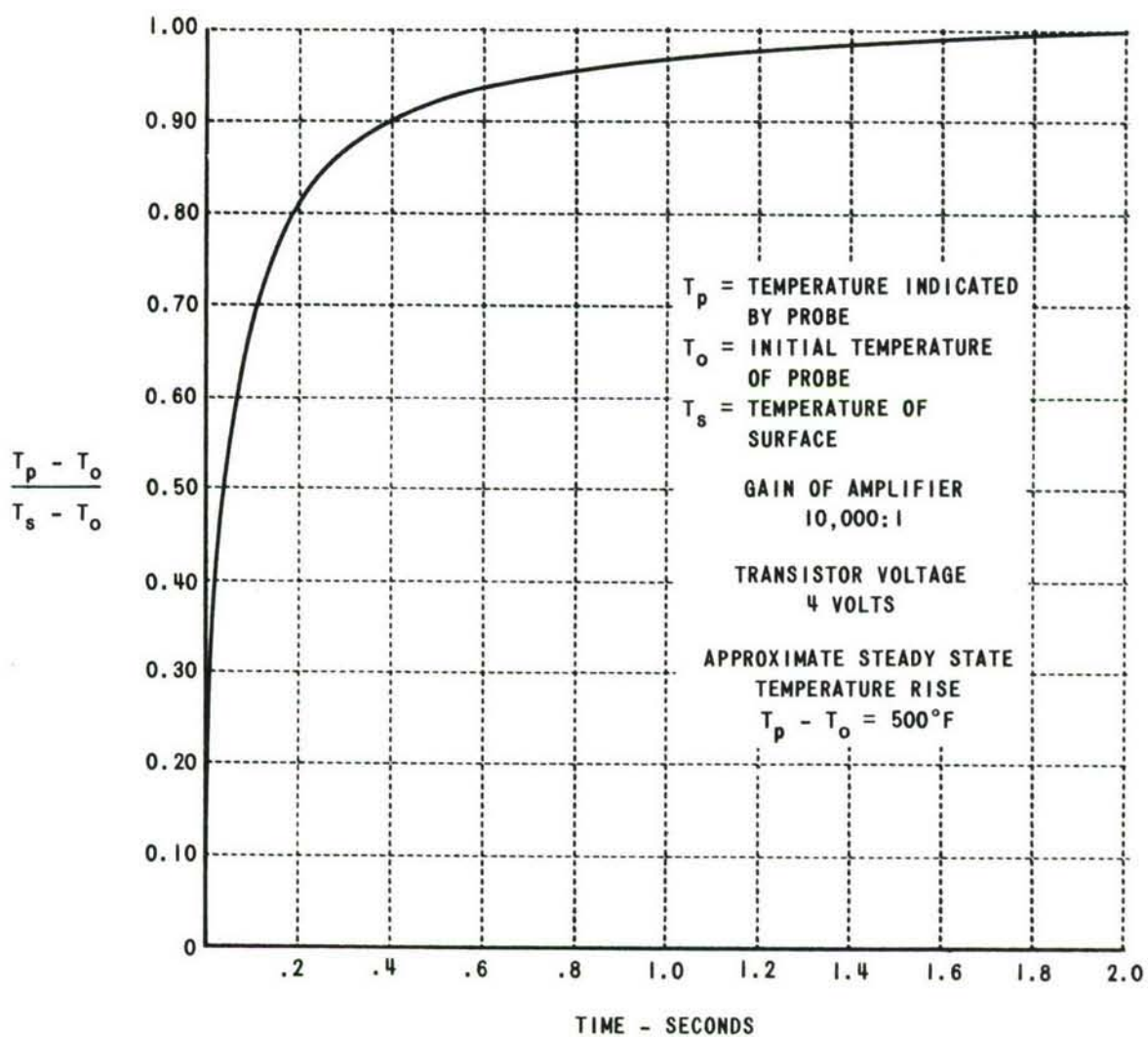

Figure 49 TEMPERATURE RESPONSE OF THE SURFACE PROBE SYSTEM

the accuracy and response as indicated by these tests were somewhat poorer than desired, but rather stable performance of the sensor-control system in these tests showed much promise as a temperature indicating system. The performance was, therefore, considered encouraging, but considerable difficulty was being encountered in the fabrication because of the requirement for an additional firing to apply the third thermocouple. For the fabrication of the three-thermocouple system, the additional firing apparently permitted more oxidation of the wires and a number of failures of the thermocouple system were experienced during handling. For this reason steps were taken to control the atmosphere during firing to limit oxidation of the thermocouples. With these probes, tests investigating the possibility of changes in the thermocouple calibration which may have been caused by deformation or oxidation of the thermocouple were investigated. No effect after repeated use of the system was found.

About this time in the development, a more practical formal configuration for the probe sensor in combination with the sting and connector was made. This configuration is shown in Figure 50.

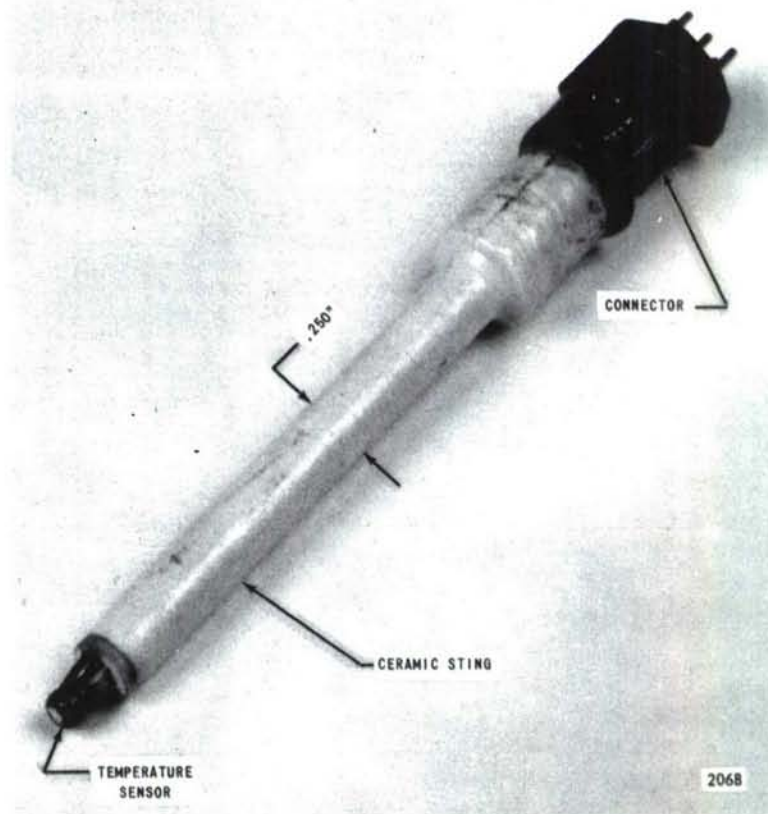

Figure 50 SURFACE TEMPERATURE PROBE MODEL I

Studies of the probe pictured above showed a response time of about 1.5 sec and an accuracy of about +1% at 500°F. At higher surface temperatures, in the range of 900°F to 1000°F, severe instability was observed. Fluctuations in the temperature were great enough to cause burnout of the platinum guard heater element. The cause of the instability was traced to induced AC from the silver test block heater. With AC of large magnitude, the platinum heater supplied heat based on the AC rather than the actual temperature unbalance in the sensor. In this case, the induced AC was sufficient to cause burnout. This situation was relieved temporarily by installing a switch in the test block windings, so that these windings could be switched off immediately before contact of the surface temperature probe. The problem was eliminated in a later sensor design.

Because of the problems of fabrication and performance, a new type of construction was investigated. This is shown in Figure 51 below:

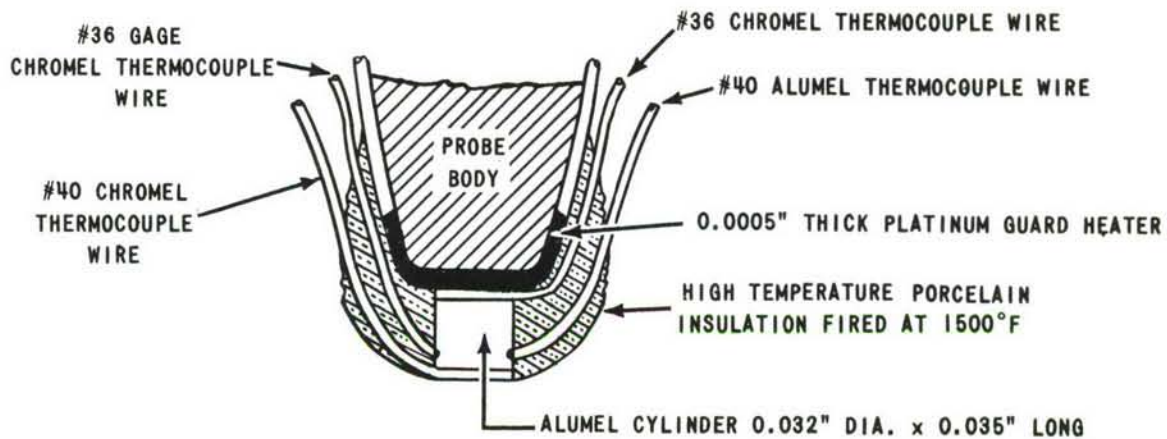

Figure 51 INTERMEDIATE SENSOR DESIGN

In this system the alumel cylinder in combination with the two 36 gage chromel wires provides a millivolt input to the electronic controller which in turn supplied corrective power to the guard heater. The temperature indication is obtained from the No. 40 chromel-alumel wires. Generally successful operation of this probe design was achieved. Negligible steady state error was observed by comparison with known test plate temperatures (error less than 0.2%). On the other hand, the probe response to step changes in temperature was poorer than desired, in the order of 6 to 10 seconds to steady state. The poor response was caused by a small temperature overshoot in the probe sensor. The overshoot occurred 1 to 2 seconds after contact with the heater test plate. An additional 6 to 8 seconds was then required to establish the final steady reading. The small overshoot in temperature was believed due to the short time lag in the controller system

which was believed to be correctible. The major advantages of this system were its adaptability to small size and the ability to make successive probes within given tolerances.

At this point in the development, the above sensor configuration held considerable promise in developing the required performance characteristics and was certainly relatively easy to fabricate. Several formidable problems still remained, however. These included:

1. The response time was still much too long.
2. Although accuracy was generally within the necessary limits, more consistency was required.
3. With glass insulation between the heater and the first sensing thermocouple, the maximum probe temperature obtainable was found to be just below 1000°F.

Modification of the probe sensor, sensor support and the heater element were then made, although the principles of operation remained identical with earlier models. A sketch of the new sensor is shown in Figure 52. This system permitted better control of the response and was very



Figure 52 SENSOR

appreciably easier to fabricate. The sensor support was "necked down" near the tip to isolate as much as possible, the sensor from the main probe body. This is shown in Figure 53. The heater element was changed in shape

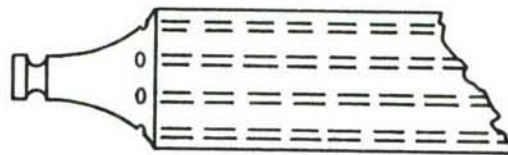

Figure 53 SENSOR SUPPORT

to permit a flatter temperature gradient for the sensor elements. These changes caused remarkable improvements in the performance of the probe. For example, the time response was improved so that it required much less

than a second to start from ambient temperature and reach the required limits of accuracy. This is shown in Figure 54. The modification of partial insulation between the differential thermocouple was introduced as a means for improving the time response because the oscillograph records showed that the heater element was shutting off too soon during the heating period for the probe. In essence, the differential thermocouples sensed a temperature inversion and limited power too quickly to

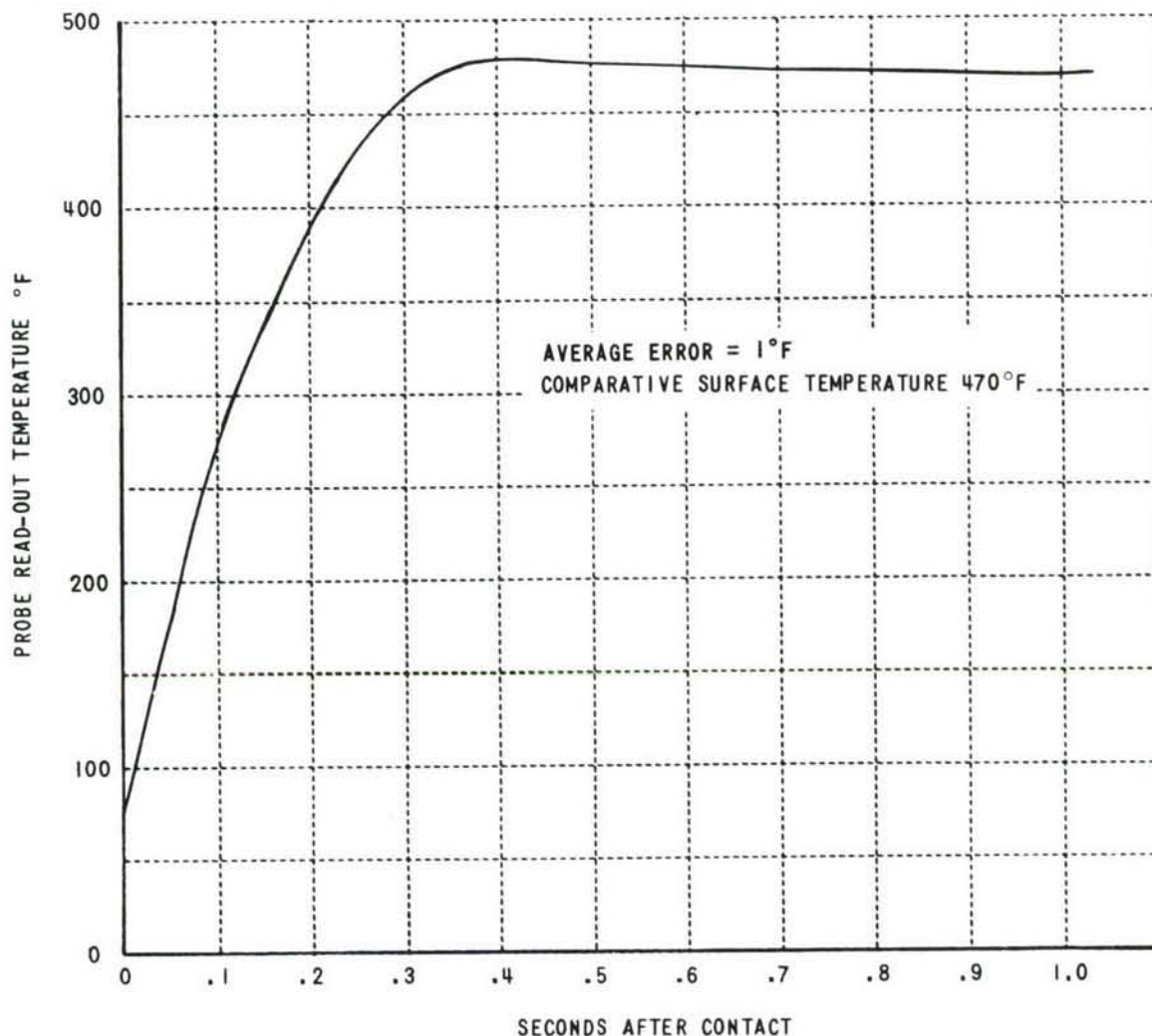

Figure 54 PROBE RESPONSE DATA

permit the most rapid approach to the correct temperature. With this configuration, the accuracy was generally in the acceptable region of $\pm 3/8\%$. Consistency of performance was improved as a result of the decrease in losses caused by the change in the heater configuration. Up to this time operation to 1000°F had not been possible because the thin (0.005") ceramic insulation between the heater and the first thermocouple had suffered breakdown during operation. This problem was solved by a

minute layer of mica in a glass separator. As a result, 1000°F could be reached without any indication of insulation failure. With the configuration which is discussed in considerable detail later, the performance of the probe sensor was considered to be within the performance goal of the development program, but testing had been limited to measuring the temperature of a standard resistance-heated surface. Therefore, the work was diverted in the direction of intense performance evaluation and adaptation to practical application. Thus, experimental work proceeded into such areas as the use of radiation heat sources and the evaluation of various performance areas such as application of the probe to a variety of materials, orientations, heating rates, etc.

During this period, the performance characteristics were evaluated on a number of materials. On all materials the probe performed well in intermittent contact. In continuous contact the probe performed well on all materials except aluminum.

With aluminum under conditions of continuous contact, performance of the early probes was good for the first 20 to 30 seconds. After that time interval, the probe would then read excessively high, as is illustrated in Figure 55 below.

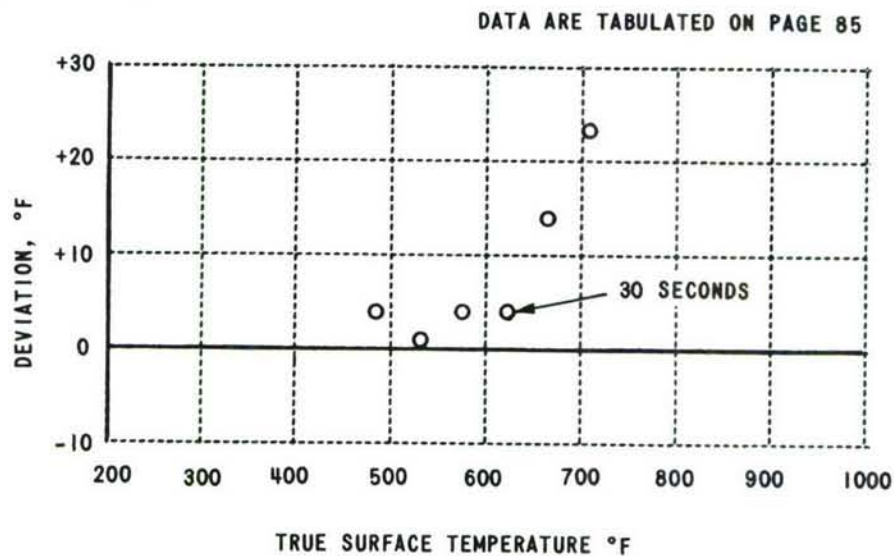

Figure 55 CONTINUOUS CONTACT ON ALUMINUM

After these results were observed, it was reasoned that the aluminum was reflecting radiant energy more than the probe and, therefore, the probe sensor area was heating faster from radiant energy than the plate. Experiments proved this to be true and an effort was made to diminish the effect by using a "skirt" around the probe tip to minimize reflection from the aluminum surface. Some results are shown in Figure 56 on the next page.

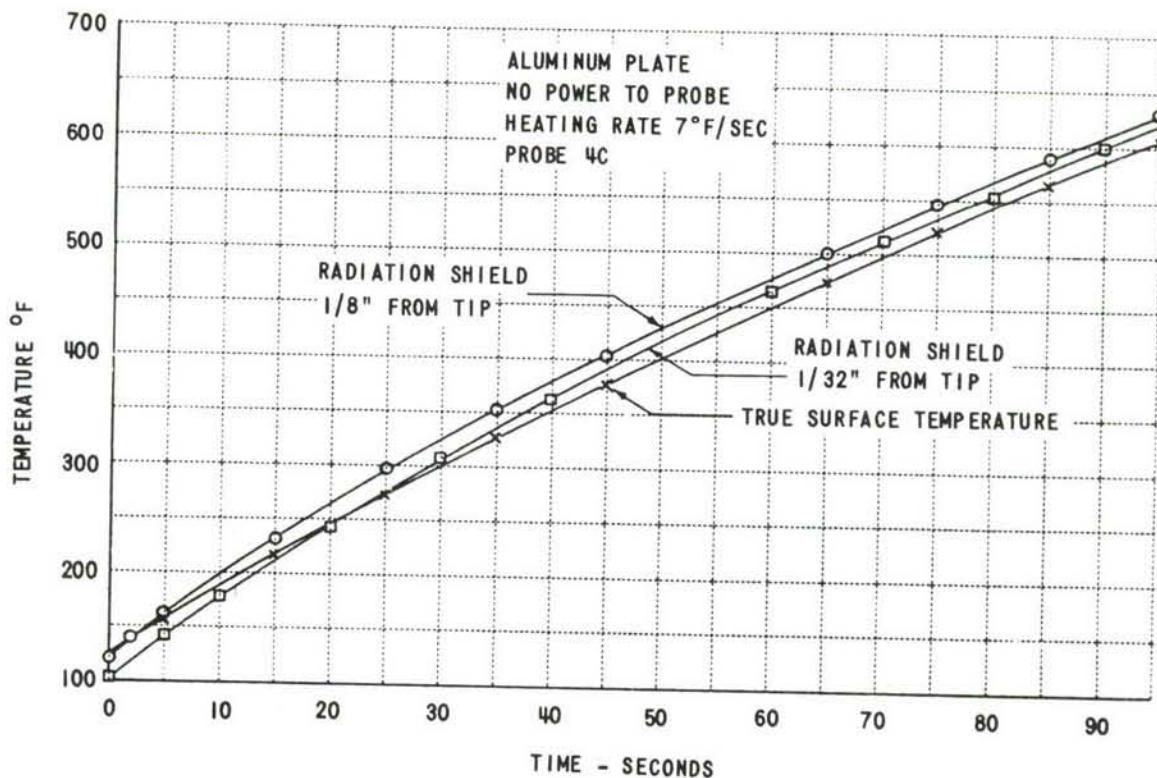

Figure 56 EFFECT OF SHIELD ON REFLECTIVE HEATING

The figure shows that the skirt has an advantageous effect in prolonging the time of accurate readings but that in power-off operation the probe will stabilize at a deviation of +14°F if the skirt clearance is 1/32" and +28°F if the skirt clearance is 1/8".

To improve this performance, a shiny gold surface was applied to the probe sting and tip. It was hoped that a greater reflectivity could be achieved in this manner. The results of the steady state tests showed a considerable improvement (see Figure 10, page 17).

On aluminum, the readings do stabilize at a maximum deviation of +8°F. Deviation is normally about zero just after contact with the surface. After one minute, the deviation may be as high as +5°F followed by a slow rise that may reach as high as +8°F.

In order to clarify some of the surface effects further, an identical aluminum test plate was anodized to blacken its surface. As expected the reflection to the probe was decreased further to the point where no positive drift is detected. This is discussed in Performance on Aluminum.

The above positive drift is now relatively small and predictable so that resultant errors can be minimized to conform to the original accuracy goals. Nevertheless, it is expected that additional improvements in sensor design will eliminate the drift completely.

APPENDIX B
FABRICATION PROCEDURE

PROBE AND HEATER

Step No. 1

A 6" length of 3/16" O.D. 6 hole insulator is machined at one end, as indicated in the following sketch:

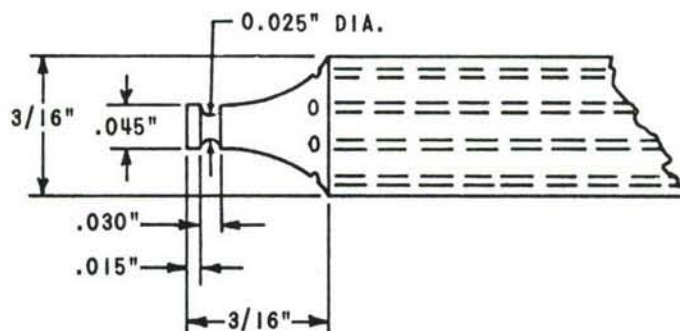

Figure 57 SENSOR SUPPORT

Step No. 2

The ceramic sting is next coated with E-Z Flow #617 Clear Brushing Glaze and fired in a vertical position (tip up) at 1650°F for 1/2 hour.

Step No. 3

Two pieces of 6 1/2" long #22 gage platinum wire flattened at one end to a thickness of 0.010" and trimmed to a length of about 0.060" and a width of 0.045" are inserted into the insulator in opposite holes and with their flat edge even with the under cut. These wires are then attached to the ceramic insulator using #3450 P ceramic coating which is flowed in small amounts into the holes and also under the flattened platinum. Only the tip of the probe is then fired in a furnace at 1550°F for 3-5 minutes.

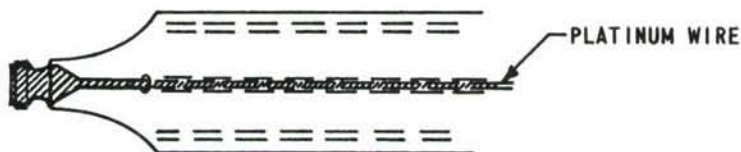

Figure 58 HEATER INSTALLATION

Step No. 4

Hanovia Liquid Bright Gold #5154 is brushed on the sting being careful not to run any into the holes or to short the platinum buss wires. It is air dried and placed in a cold furnace in a vertical position and fired to 1225°F allowing 1 1/2 hours to reach this temperature. The furnace must be ventilated. A second coat of gold may or may not be necessary.

Step No. 5

A strip of 0.001" platinum foil by 0.040" wide and approximately 5/16" long (with the roll marks running the length) is annealed and spot welded to one of the platinum buss wires. The foil is then carefully formed into the groove over the face of the sting and back around to the other buss.

Step No. 6

The platinum heater is then glassed into position by filling the groove with 3450 P Ceramic coating and also painting over the buss and foil weld joint - then it is fired as in Step No. 3. The probe is quickly removed from the furnace and the tip of probe is pressed against a flat metal surface to position the heater against the ceramic tip of the sting. This completes the heater and sting fabrication.

SENSOR FABRICATION AND ASSEMBLY

Step No. 7

A ceramic spacer about 0.042" in diameter with a 0.013" hole is ground to a wafer 0.010" thick.

Step No. 8

(Note: see cross section drawing.) A 7" length of #36 gage teflon covered alumel wire is bared for about 3/16" and flattened for about 1/8" but not enough to exceed the hole diameter of the ceramic wafer. The flattened section is then bent at right angles about 1/16" from the end.

Step No. 9

A 7" length of #36 gage teflon-covered, chromel wire is next flattened on one end to a thickness of 0.001".

Step No. 10

A 14" length of 40 gage teflon-covered, chromel wire is bared in the center for about 1/8" and then flattened to ~ 0.0075 " thick producing a small disc at the midpoint of the wire about 0.015" wide by 0.45" long.

Step No. 11

All components are assembled and welded as seen in cross-section and top view (Figure 60).

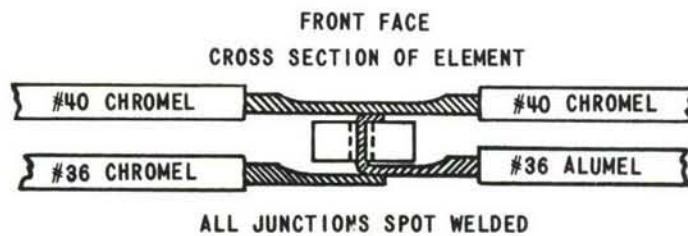

Figure 59 SENSOR

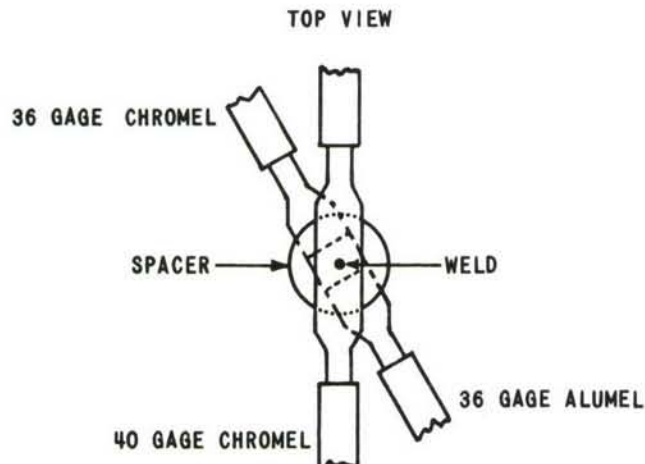

Figure 60 SENSOR

Step No. 12

The thermocouple element is assembled to the probe by carefully feeding the thermocouple wires through the remaining 4 holes in the probe sting making sure that the 40 gage chromel wire will form the outermost thermocouples. The thermocouple wires are bent to fit the probe sting.

A small square of mica 0.050" x 0.050" by .005" thick is inserted between the element and heater strip. The element is positioned so that tight contact is made between all elements making sure that they are centered with the heater.

The thermocouple wires are loaded so that the element will not shift when firing the next glass glaze. (Check to make sure that there is no short circuit between the element and heater.)

Step No. 13

The #3450 P ceramic glaze is lightly applied to the thermocouple wires and ceramic and also to the mica on the back side - being careful not to get any of the glaze on the thermocouple element because this will effect the response time.

Step No. 14

The tip is then fired at 1550°F for 3-5 minutes.

A Winchester type plug M-9P and hood assembly is used for the wiring connector. The connections are as follows:

	Pins C & H	- Platinum buss-power
To Controller	Pin B	- 40 gage chromel
	Pin U	- 36 gage chromel
Temperature	Pin D	- 36 gage alumel
	Pin F	- 40 gage chromel

The hood must be drilled to pass the 3/16" ceramic sting and then, after assembly to the plug, is cemented with Hysol to the sting for strength and rigidity.

APPENDIX C ATTACHMENT OF THERMOCOUPLES TO NON-METALS

Non-metallic materials generally require an intermediate bonding agent for attachment of thermocouples. Suitable bonding agents must meet at least the following requirements:

1. Bond strength capable of withstanding forces applied in handling the thermocouple wires, arising from the elastic restoring forces in bent wires and resulting from thermal stresses.
2. Resistance to elevated temperatures roughly comparable to the temperature capabilities of the plastic or ceramic material to which it is applied.
3. Reasonably good thermal conductivity or capability of use in extremely thin coats.
4. Easy application.

Certain adhesives meeting these and other requirements are discussed **below** for organic and ceramic surfaces. Techniques of application are also given.

Bonding Thermocouples to Plastics

It has been found that a proprietary conductive paint^{*} containing of the order of 25% silver metal powder is a satisfactory bonding agent on plastics. This paint retains adequate strength and thermal conductivity in the 400-500°F range, but probably would not be useful above 500°F. Hardening is by solvent loss, which appears to be acceptable in the case at hand, where the volume of bonding agent used is very small. (Solvent-loss adhesives are, of course, inferior to resin-catalyst systems in many other applications.) This paint should be suitable for most organic surfaces. However, if chemical incompatibility is found in a particular case, an appropriate resin could be selected and modified, by the addition of very fine silver powder, to have adequate thermal conductivity. Silver is preferred over other metals because of its high thermal conductivity and relative freedom from surface oxidation.

* See page 43.

Certain plastics, notably silicones, can withstand temperatures over 500°F for prolonged periods. Where surface temperatures of such materials are to be measured, it should be possible to bond thermocouples with a silicone based adhesive, again modified by the addition of silver powder.

Bonding Thermocouples to Ceramics

Temperatures exceeding 600-700°F demand a ceramic or glossy bonding agent. Three main types of cements are available, although differences among the types are considered to be somewhat arbitrary. The three types are:

1. Water solutions of soluble inorganic compounds, mainly sodium silicate with powdered fillers such as oxides and refractory silicates. In these cements hardening occurs by loss of water at moderate temperatures, but firing at high temperatures causes formation of a true ceramic consisting of silicate-base glass and residual crystalline filler.
2. Silicate and other glasses in which bonding to ceramic or metal is developed only upon heating the glass to a temperature at which it is fluid.
3. Acid-setting cements in which hardening first occurs by reaction of phosphoric acid with an oxide powder to produce a phosphate compound. Heating to high temperature produces a refractory phosphate glass or crystalline phosphate in combination with residual oxide particles.

Another broad area of ceramic-metal bonding involves "metallizing" the ceramic surface in some way followed by soldering or brazing. The required techniques are considered to be more difficult and exacting than those involved in applying the ceramic cements.

In view of the above, a proprietary sodium-silicate refractory cement* (type 1 above) was selected for trial. This cement was found to produce a satisfactory bond to ordinary soda-lime glass and to "lava" (natural pyrophyllite) ceramic. The bond appears to have sufficient thermal conductivity without modification; however it would be possible to add silver or noble-metal powders if necessary.

At temperatures above 2000°F when platinum thermocouples are used, silica-containing cements are generally avoided because of their detrimental effect on platinum. In this case it should be possible to use a proprietary

*Sauerlesen Insulate Cement #1 Paste, Sauerlesen Cement Company, Pittsburgh, Pennsylvania.

silica-free cement such as those manufactured by Norton Company. It might, however, be necessary to ball-mill such cements to reduce particle size so that very thin bond-layers could be obtained.

Techniques of Application

In this report it is recommended that fine wire thermocouples be used to minimize errors caused by thermal conduction through the leads. This is especially true for non-metal surfaces which generally have thermal conductivity properties considerably lower than metals. It is therefore recommended that the finest wire possible compatible with practical operational reliability be used on non-metal surfaces. For better heat transfer between the thermocouple and the surface, the thermocouple junction and a short length of each lead should be flattened and attached to the surface with the appropriate adhesive. The adhesive should be used sparingly permitting only the thinnest practical interfacial layer. Unless the adhesive has radiation characteristics similar to the surface, its area of application should not extend beyond the area covered by the wire. Because the thermocouple wire will generally have a different reflectivity than the non-metallic surface, it is desirable to have the thermocouple cover a minimum of area and therefore a compromise must be reached between more flattening for greater adhesion and less flattening to minimize heat absorption distortion. To avoid the radiation absorption distortion problem in some cases, the thermocouple can be covered with a thin coat of surface material. This is possible where resins are used as adhesives on resin surfaces and can also be used as a surface coating for the flattened thermocouple junction.

TABLES OF DATA

The following tables include the data for a number of figures used in the report. All of the columns report temperatures in °F. The Reference temperature is the true surface temperature. The second temperature column is the comparative temperature (under Probe 5A for Fig. 9) measured on the surface by probe or surface thermocouple techniques. The deviation is the comparative temperature minus the reference temperature.

Figure 9 Transient Tests on Aluminum

<u>Reference</u>	<u>Probe 5A</u>	<u>Deviation</u>
414.0°F	409.3°F	-4.7°F
543.0	542.0	-1.0
414.0	409.3	-4.7
543.0	542.0	-1.0
630.0	628.0	-2.0
713.7	713.7	0.0
789.7	789.7	0.0
849.0	848.7	-0.3
931.0	930.0	-1.0
959.7	959.7	0.0

Figure 12 Intermittent Transient Tests on Magnesium

Run 1A

<u>Reference</u>	<u>Probe 5A</u>	<u>Deviation</u>
388.0	379.3	-8.7
610.5	607.0	-3.5
747.0	747.0	0.0
865.0	867.6	2.6

Run 2A

<u>Reference</u>	<u>Probe 5A</u>	<u>Deviation</u>
341.5	334.6	-6.9
488.5	484.5	-4.0
658.0	658.0	0.0
765.0	765.0	0.0
863.0	859.3	-3.7

Figure 12 Intermittent Transient Tests on Magnesium (Cont.)

Run 3B

<u>Reference</u>	<u>Probe 5B</u>	<u>Deviation</u>
320.0	314.0	-6.0
481.0	479.5	-1.5
646.0	640.7	-5.3
783.5	783.5	0.0

Run 5A

<u>Reference</u>	<u>Probe 5A</u>	<u>Deviation</u>
409.0	409.0	0.0
602.7	602.1	-0.6
813.7	815.0	1.3

Figure 14 Probe Accuracy on Hot Rolled Steel

<u>Reference</u>	<u>Intermittent</u>		<u>Continuous Contact</u>	
	<u>Probe 4C</u>	<u>Deviation</u>	<u>Probe 4C</u>	<u>Deviation</u>
229.0			229.0	0.0
347.0			348.5	1.5
450.0			452.0	2.0
516.0	519.4	3.4		
535.0	537.0	2.0		
546.0			548.0	2.0
590.0	595.0	5.0		
610.0	614.5	4.5		
638.0			640.0	2.0
652.0	657.0	5.0		
669.0			672.5	3.5
700.0	705.2	5.2		
722.0	725.0	3.0		
772.0	777.0	5.0		
791.0			792.0	1.0
795.0	797.0	2.0		
846.0	851.0	5.0		
850.0			851.0	1.0
859.0	861.0	2.0		

Figure 15 Probe Accuracy on Stainless Steel

<u>Continuous Contact</u>			<u>Intermittent Contact</u>		
<u>Reference</u>	<u>Probe 4C</u>	<u>Deviation</u>	<u>Reference</u>	<u>Probe 4C</u>	<u>Deviation</u>
526.0	530.0	4.0	330.0	333.0	3.0
588.0	591.0	3.0	356.0	354.0	-2.0
654.0	656.0	2.0	522.0	527.0	5.0
720.0	723.0	3.0	553.0	555.0	2.0
785.0	788.0	3.0	661.0	664.0	3.0
845.0	848.0	3.0	695.0	693.5	-1.5
			770.0	773.0	3.0
			799.0	801.0	2.0
			861.0	863.0	2.0
			874.0	871.5	-2.5

Figure 17 Intermittent Transient Tests on Titanium

Run 9A

<u>Reference</u>	<u>Probe 5A</u>	<u>Deviation</u>
417.0	408.5	-8.5
581.5	578.0	-3.5
695.6	692.3	-3.3
787.0	786.0	-1.0
894.0	897.0	3.0
967.0	966.5	-0.5
1018.6	1018.6	0.0

Run 10A

<u>Reference</u>	<u>Probe 5A</u>	<u>Deviation</u>
626.0	623.5	-2.5
739.3	740.0	0.7
830.5	828.6	-1.9
972.3	976.5	4.2
1031.5	1035.6	4.0

Figure 19 Intermittent Transient Tests on Fiberglas Laminate of CTL Resin

Run 1

<u>Reference</u>	<u>Probe 4C</u>	<u>Deviation</u>
147.3	143.0	-4.3
202.0	199.0	-3.0
210.0	207.5	-2.5
278.0	278.0	0.0
284.6	284.6	0.0

Figure 19 Intermittent Transient Tests on Fiberglas Laminate of CTL Resin (Cont.)

Run 2

<u>Reference</u>	<u>Probe 4C</u>	<u>Deviation</u>
203.5	195.0	-8.5
240.6	238.0	-2.6
328.5	327.5	-1.0

Run 3

<u>Reference</u>	<u>Probe 4C</u>	<u>Deviation</u>
195.6	200.0	4.4
309.5	309.5	0.0

Figure 33 Effects of Rate of Heating

10°F/Sec. at 500°F

<u>Reference</u>	<u>24-28 Gage Chr-Al</u>	<u>Deviation</u>
173.3	182.0	8.7
291.5	303.0	11.5
400.5	413.0	12.5
550.0	565.0	15.0
645.0	657.6	12.6
731.0	743.5	12.5
807.5	819.0	11.5
879.0	891.0	12.0
913.0	925.5	12.5
972.0	982.0	10.0

2.7°F/Sec. at 500°F

<u>Reference</u>	<u>24-23 Gage Chr-Al</u>	<u>Deviation</u>
508.5	509.0	.5
535.3	537.6	2.3
562.6	565.1	2.5
588.0	591.8	3.8
612.6	615.5	2.9
635.5	640.0	4.5
657.0	661.3	4.3
676.0	680.0	4.0
694.5	700.0	5.5

Figure 33 Effects of Rate of Heating (Cont.)

<u>Reference</u>	<u>10°F/Sec. at 500°F</u> <u>Probe 5A</u>	<u>Deviation</u>
526.0	530.0	4.0
588.0	590.7	3.7
656.0	657.8	1.8
723.0	726.1	3.1
788.0	790.8	2.8
848.0	851.0	3.0

Figure 34 Effect of Wire Size

<u>Reference</u>	<u>24-28 Gage</u> <u>Chr-Al</u>	<u>Dev.</u>	<u>30 Gage</u> <u>Chr-Al</u>	<u>Dev.</u>	<u>36 Gage</u> <u>Chr-Al</u>	<u>Dev.</u>	<u>Probe 5A</u>	<u>Dev.</u>
173.0	184.0	11.0						
202.5					208.0	5.5		
291.5	303.0	11.5						
311.3					317.0	5.7		
327.5			336.8	9.3				
385.0			394.5	9.0				
400.5	413.0	12.5						
415.0					420.5	5.5		
445.0			451.5	6.5				
514.6					519.0	4.4		
525.0							528.5	3.5
550.0	565.0	15.0						
552.0			557.3	5.3				
581.0							584.0	3.0
609.6					613.3	3.7		
645.0	657.0	12.0						
652.0			660.0	7.4			654.0	2.0
692.0					695.5	3.2		
718.0							721.3	3.3
731.0	743.5	12.5						
745.6			750.5	4.9				
770.0					772.0	2.0		
788.0							791.3	3.3
807.5	819.0	11.5						
830.0			834.6	4.6				
838.5					841.0	2.5		
840.0							843.0	3.0
879.0	892.0	12.0						
913.0	925.5	12.5						
926.0					938.0	2.0		
937.6			941.0	3.4				
972.3	982.0	12.0			975.5	3.2		
997.6			1002.3	4.7				

Figure 35 Performance of Various 36 Gage Thermocouples on Aluminum

Ref. Temp. °F	36 Gage I. C. 7.0°/sec		36 Gage Chr-Al 6.9°/sec		36 Gage Chr-Al 7.0°/sec		Probe 5A 7.0°/sec	
		Dev.		Dev.		Dev.		Dev.
103.0			103.0	0.0				
162.5			167.0	4.5				
190.0	186.3	3.7						
247.0			251.3	4.3				
250.5					251.0	.5		
289.0	292.0	3.0						
296.0					293.3	-2.7		
323.5			327.5	4.0				
336.5					337.2	0.7		
372.5	375.0	2.5						
377.0					377.6			
392.2			395.5	3.2				
413.0					415.0	2.0	408.7	-4.3
447.3	451.5	4.2						
448.5					451.4	2.9		
458.0			461.0	3.0				
484.0					487.0	3.0		
517.0	525.6	8.6	519.0	2.0				
519.0					520.0			
545.0							543.8	-1.2
569.6			572.0	2.4				
578.0					582.5			
582.3	570.6	8.3		8.3				
610.0					612.5	2.5		
618.3			620.0	1.7				
632.0							630.2	-1.8
635.5					640.0	4.5		
640.6	649.6	9.0						
661.5					663.0	1.5		
662.3			664.5	2.5				
684.0					685.5	1.5		
694.5	704.6	10.0						
701.0			703.5	2.5				
706.0					710.0	4.0		
715.0							715.0	0.0
727.0					731.0	4.0		
737.0			738.5	1.5				
739.6	753.6	14.0						
748.0					752.0	4.0		
766.0			768.3	2.3				
775.0	790.0	15.0						
792.5			794.5	2.0			792.5	0.0
811.6	825.5	13.7						
816.3			819.0	2.7				
838.5			840.5	2.0				
841.5	861.3	19.8						
855.0							855.0	0.0
935.0							934.0	-1.0
965.0							964.5	-0.5
1004.0							1001.3	-2.7

Figure 36 Comparative Test on Stainless Steel

Reference	24 Gage I. C. 1.77/sec	Dev.	Reference	24 Gage I. C. 8.47/sec	Dev.	Reference	24-28 Gage 1.77sec	Dev.
71.5	71.5	1.5	140.0	152.1	12.1	76.0	79.4	3.4
132.0	134.2	2.2	268.0	283.8	15.8	109.0	111.8	2.8
192.0	195.3	3.3	399.0	434.0	35.0	170.0	173.4	3.4
246.0	251.0	5.0				228.0	233.0	5.0
295.0	304.1	9.1				278.0	281.6	3.6
318.0	326.2	8.2				318.0	321.5	3.5

Reference	24-28 Gage Chr-Al 8.47/sec	Dev.	Reference	Probe 4C	Dev.
135.0	144.0	9.0	330.0	330.0	0
261.0	267.6	6.6	522.0	526.0	4.0
382.0	392.0	10.0	589.0	592.0	3.0
504.0	514.6	10.6	660.0	661.9	1.9
612.0	622.8	10.8	720.0	722.7	2.7

Reference	36 Gage Chr-C 8.147/sec	Dev.	Reference	36 Gage Chr-C 2.47/sec	Dev.
172.5	179.3	6.8	194.0	196.7	2.7
255.6	264.4	8.8	260.0	263.7	3.7
341.0	349.0	8.0	311.3	316.6	5.3
429.5	437.0	7.5	373.5	377.5	4.0
509.5	518.0	8.5	431.6	436.0	4.4
592.3	599.0	8.7	486.0	490.0	4.0
665.6	673.2	7.6	534.0	537.0	3.0
739.3	744.8	5.5	576.0	580.0	4.0
804.0	813.4	9.4	612.0	616.6	4.6
862.5	871.0	8.5	643.0	647.7	4.7
912.3	923.0	10.7			
961.3	972.0	11.0			

Figure 37 Comparative Tests on Titanium

<u>Reference</u>	<u>24 Gage I. C.</u> <u>10.3 °F/sec</u>	<u>Dev.</u>
158.0	163.0	5.0
303.0	308.0	5.0
435.0	444.0	9.0
568.0	182.0	14.0

<u>Reference</u>	<u>24-28 Gage</u> <u>Chr-Al</u> <u>13.3 °F/sec</u>	<u>Dev.</u>
155.0	155.3	0.3
248.0	254.5	6.5
397.0	406.0	9.0
527.0	535.5	8.5
648.0	657.7	9.7
757.0	766.0	9.0
847.0	853.0	6.0
927.0	936.7	9.7
1000.0	1001.4	1.4

Figure 38 Transient Test on Stainless Steel

<u>Reference</u>	<u>36 Gage Chr-Al</u>	<u>Dev.</u>
310.0	309.0	-1.0
515.0	515.5	0.5
686.0	688.3	2.3
801.0	803.6	2.6
884.0	886.6	2.6
974.0	976.3	2.3
1021.0	1023.2	2.2

Figure 39 Comparative Tests on Titanium

<u>Reference</u>	<u>10.3°F/sec</u>	
	<u>24 Gage I. C.</u>	<u>Deviation</u>
158.5	163.0	4.5
303.5	308.3	4.8
435.3	444.3	14.0

<u>Reference</u>	<u>13.3°F/sec</u>	
	<u>24-28 Chr-Al</u>	<u>Deviation</u>
158.0	158.0	0.0
249.0	255.6	6.6
392.3	401.6	9.3
525.6	534.0	8.4
647.0	657.0	10.0
752.0	761.0	9.0
843.5	850.0	6.5
925.0	935.0	10.0
994.5	1006.0	11.5

<u>Reference</u>	<u>10.9°F/sec</u>	
	<u>Probe 5A</u>	<u>Deviation</u>
417.0	408.5	-8.5
581.5	578.0	-3.5
695.6	692.3	-3.3
787.0	786.0	-1.0
894.0	897.0	3.0
967.0	966.5	-1.5
1018.6	1018.6	0.0

Figure 40 Comparative Tests on Magnesium

<u>Reference</u>	<u>16.4°F/sec</u>	
	<u>24-28 Gage Chr-Al</u>	<u>Deviation</u>
143.0	143.0	0.0
201.6	201.6	0.0
298.5	302.6	4.1
390.5	393.5	3.0
554.0	557.5	3.5
683.0	686.6	3.6
791.0	796.3	5.3

<u>Reference</u>	<u>16.9°F/sec</u>	
	<u>Probe 5A</u>	<u>Deviation</u>
341.5	334.6	-6.9
488.5	484.5	-4.0
658.0	658.0	0.0
765.3	765.3	0.0
863.0	859.3	-3.7

Figure 41 Comparative Tests on Plastics

<u>Reference</u>	<u>7°F/sec</u>	
	<u>36 Gage Chr-Al</u>	<u>Deviation</u>
172.5	182.0	9.5
242.5	251.3	8.8
304.0	309.5	5.5
352.5	358.0	5.5
399.5	401.6	2.1
436.0	440.5	4.5

<u>Reference</u>	<u>Probe 4C</u>	<u>Deviation</u>
156.0	150.6	-5.4
202.0	199.0	-3.0
207.0	205.5	-1.5
247.0	243.0	-4.0
278.0	278.0	0.0
309.5	309.5	0.0
328.5	327.5	-1.0

Figure 42 Effect of Orientation on Aluminum

Plate Horizontal - 5.9 °F/sec

<u>Reference</u>	<u>36 Gage Chr-Al</u>	<u>Deviation</u>
165.0	170.0	5.0
245.0	250.0	5.0
325.0	329.5	4.5
395.0	398.2	3.2
462.0	465.2	3.2
514.0	516.0	2.0
570.0	772.5	2.5
665.0	666.9	1.9
700.0	702.6	2.6
734.0	735.7	1.7
762.0	764.3	2.3
796.0	798.3	2.3
812.0	815.0	3.0
838.0	840.2	2.2

Plate Vertical - 10.0 °F/sec

<u>Reference</u>	<u>36 Gage Chr-Al</u>	<u>Deviation</u>
202.0	207.7	5.7
295.0	298.5	3.5
375.0	378.5	3.5
550.0	554.2	4.2
607.0	610.4	3.4
663.0	666.3	3.3
707.0	710.6	3.6
745.0	747.9	2.9
780.0	783.5	3.5
807.0	811.2	4.2

Plate Vertical - 8.3 °F/sec

<u>Reference</u>	<u>36 Gage Chr-Al</u>	<u>Deviation</u>
221.0	227.5	6.5
335.0	338.0	3.0
434.0	436.4	2.4
528.0	530.5	2.5
645.0	647.4	2.4
755.0	756.8	1.8
807.0	811.2	4.2

Figure 42 Effect of Orientation on Aluminum (Cont.)

<u>Reference</u>	<u>5.5°F/sec</u>	
	<u>Probe 5B</u>	<u>Deviation</u>
300.0	306.3	6.3
587.0	591.7	4.7
689.0	691.5	2.5
857.0	859.3	2.3

Figure 43 Effect of Orientation on Stainless Steel

<u>Ref. Temp.</u>	<u>Plate Horiz.</u>		<u>Plate Vert.</u>		<u>Plate Vert.</u>		<u>Probe 5B</u>	
	<u>Dev.</u>	<u>Dev.</u>	<u>Dev.</u>	<u>Dev.</u>	<u>Dev.</u>	<u>Dev.</u>	<u>Dev.</u>	
282.5	289.5	17.0						
297.0							281.0	-6.0
312.5					321.0	8.5		
323.0			332.3	9.3				
396.0	408.5	12.5						
426.5					436.0	9.5		
435.3			443.5	8.2				
530.0					539.0	9.0		
537.5			544.6	7.1				
543.0							546.0	3.0
545.0	556.3	11.3						
625.5					636.5	11.0		
629.5	644.3	14.8						
632.0			641.0	9.0				
689.0							688.0	-1.0
708.0	722.5	14.5						
712.0					721.5	9.5		
717.0			724.5	7.5				
778.5	788.5	10.0						
788.0					788.0	10.0		
792.5			799.0	6.5				
839.0	853.0	14.0						
856.0					865.6	10.1		
858.0			864.0	6.5				
870.0							871.1	1.1
914.0	968.0	14.0						
939.6			945.3	5.7				
939.3					949.5	11.2		
954.0	968.0	14.0						
984.0			989.3	5.3				
984.5					995.6	12.1		
988.5	1002.0	13.5						
1003.0							101.0	7.0

Figure 55 Continuous Contact on Aluminum

<u>Reference</u>	<u>Probe 4C</u>	<u>Deviation</u>	<u>Time from Contact Seconds</u>
481.0	485.0	4.0	0
530.0	531.0	1.0	10
575.0	579.0	4.0	20
622.0	626.0	4.0	30
664.0	678.0	14.0	40
704.0	727.0	23.0	50