

**UNCLASSIFIED**

---

---

**AD 404 633**

*Reproduced  
by the*

**DEFENSE DOCUMENTATION CENTER**

FOR

**SCIENTIFIC AND TECHNICAL INFORMATION**

CAMERON STATION, ALEXANDRIA VIRGINIA



---

---

**UNCLASSIFIED**

NOTICE: When government or other drawings, specifications or other data are used for any purpose other than in connection with a definitely related government procurement operation, the U. S. Government thereby incurs no responsibility, nor any obligation whatsoever; and the fact that the Government may have formulated, furnished, or in any way supplied the said drawings, specifications, or other data is not to be regarded by implication or otherwise as in any manner licensing the holder or any other person or corporation, or conveying any rights or permission to manufacture, use or sell any patented invention that may in any way be related thereto.

63-3-4

404 633

404633

ASTIA

CALIFORNIA

DDC

RECEIVED  
MAY 10 1963  
ASTIA D



**RESEARCH AND INVESTIGATION OF  
MATERIALS FOR  
LASER APPLICATIONS**

**R. FITZPATRICK  
S. E. SOBOTKA**

**WATKINS-JOHNSON COMPANY  
3333 Hillview Avenue  
Palo Alto, California**

**Contractor's Report No. W-J 63-612R12**

**Interim Engineering Report No. 3  
for the period 1 January through 31 March 1963**

**This applied research reported in this document has been made possible through support and sponsorship extended by the Electronics Technology Laboratory of the Aeronautical Systems Division. It is published for technical information only, and does not necessarily represent recommendations or conclusions of the sponsoring agency.**

**Contract No. AF 33(657)-8917  
BPSN 2(670)-4159-41652**

**ELECTRONIC TECHNOLOGY LABORATORY  
AERONAUTICAL SYSTEMS DIVISION  
AIR FORCE SYSTEMS COMMAND  
UNITED STATES AIR FORCE  
WRIGHT-PATTERSON AIR FORCE BASE  
DAYTON, OHIO**

## SUMMARY

Two areas of effort were emphasized during the past quarter: studies of the light emission from pulsed diodes made of Nd doped GaAs and studies of undoped GaAs lasers.

For the Nd doped diode studies, two different doped GaAs samples were used: one of single crystal material containing an amount of Nd determined by independent analysis to be about 0.01 percent, and one of polycrystalline material containing about 0.7 percent Nd which is distributed in an unknown manner. Emission measurements on diodes made from the Nd doped material revealed lines in the range of 1.0 to 1.1  $\mu$ . These lines were not observed with five (5) undoped GaAs diodes measured. These lines are indicated to be Nd emission. This, to our knowledge, is the first time that emission from rare earth ions has been reported. The results obtained indicate that dc excitation of rare earth centers in semiconductors is possible as predicted originally. The possibility of a low-threshold dc-pumped laser using rare earth doped semiconductors seems assured.

Diodes made from GaAs without Nd have been fabricated according to techniques designed to optimize laser action. Studies of the emission of these diodes, integrated over all wavelengths, have been made as a function of current, up to 10 amps peak, with the diode immersed in liquid N<sub>2</sub>. The results indicate that laser action occurs at peak currents above a few amps ( current densities about  $10^3$  amp/cm<sup>2</sup> ).

## TABLE OF CONTENTS

	<u>Page No.</u>
<b>STUDIES OF Nd DOPED GaAs</b>	<b>1</b>
<b>Spectrochemical Analysis and Nd Concentrations</b>	<b>1</b>
<b>Absorption Measurements</b>	<b>2</b>
<b>Luminescent Diode Fabrication</b>	<b>2</b>
<b>Emission Measurements</b>	<b>3</b>
<b>STUDIES OF LASER DIODES</b>	<b>5</b>
<b>Laser Diode Fabrication</b>	<b>5</b>
<b>Emission From Laser Diode</b>	<b>9</b>
<b>CONCLUSIONS</b>	<b>12</b>
<b>RECOMMENDATIONS</b>	<b>12</b>
<b>REFERENCES</b>	<b>13</b>

## LIST OF ILLUSTRATIONS

		<u>Page No.</u>
Fig. 1	Emission of Nd doped GaAs diode at 77°K	4
Fig. 2	Geometry of laser diode.	6
Fig. 3	Photograph of GaAs laser diode.	7
Fig. 4	Current-voltage characteristic of laser diode.	8
Fig. 5	Sketch of apparatus used for cooling the photo-multiplier cathode and the diode in liquid N <sub>2</sub> .	10
Fig. 6	Emission vs current for GaAs laser diode.	11

## STUDIES OF Nd DOPED GaAs

Studies were made on two samples of Nd doped GaAs during the last quarter. One was of single crystal material supplied by Merck and Company and, according to their spectrochemical measurements, contained 0.03 percent Nd by weight. The other was of polycrystalline material, also supplied by Merck and Company, and contained 0.7 percent Nd according to their spectrochemical measurements. Both were doped during growth from the melt and contained no other intentional dopants. The first sample was n-type with a carrier concentration of  $7.7 \times 10^{16} \text{ cm}^{-3}$ ; the second sample was also n-type with an, as yet, unmeasured carrier concentration.

### Spectrochemical Analysis and Nd Concentrations

In order to check the spectrochemical measurements of Merck, we subjected the first sample to a similar analysis. A synthetic standard was prepared by thoroughly mixing together finely divided powders of GaAs and NdAs to a final concentration of 0.01 percent Nd. This standard was compared in an arc type emission spectrograph ( Applied Research 1.5 meter grating instrument ) with powdered samples of the unknown. With this comparison, the nominal limit of detectability was about 0.005 percent Nd. No Nd emission was observed within this detectability limit.

The difference between the results of the analysis made by Merck and the one made by us probably can be taken as a realistic indication of the reliability of such emission measurements when such small concentrations must be dealt with. We would regard the two separate measurements to indicate a Nd concentration which is small and probably somewhat less than 0.03 percent. A more accurate analysis can be made by using neutron activation techniques with radio-chemical separation. We reserve this possibility until further electroluminescence measurements are made on diodes fabricated from the sample because of the expense and time required.

The second sample supplied to us by Merck is heavily doped ( a 0.7 percent Nd ) and, apparently because of that, is polycrystalline. However, the crystallite sizes are large enough ( max. dia.  $\sim 1 \text{ mm}$  ) so that diodes can be made from the material.



### Absorption Measurements

An absorption measurement was made on the single crystal Nd doped sample in an effort to detect  $\text{Nd}^{3+}$  absorption lines. Absorption from the ground state to the  ${}^4\text{F}_{3/2}$  level of  $\text{Nd}^{3+}$  can be expected to occur at wavelengths between 8500 Å and 9500 Å, so this range was searched carefully. In order to prevent a large amount of absorption in this region due to the GaAs absorption edge, the sample was cooled nearly to liquid  $\text{N}_2$  temperature by mounting it on the copper cooling finger of a dewar flash. Measurements were made in a Cary Model 14 double-beam spectrophotometer using a PbS detector. With this arrangement, it was easily possible to measure an absorption constant of 0.05 with a resolution of 10 Å.

No evidence of anything but band edge absorption was observed. We place this measurement in perspective by considering the following facts:

If a Nd concentration of 0.01 percent is assumed, the minimum detectable cross-section was about  $10^{-19} \text{ cm}^2$  for absorption to the  ${}^4\text{F}_{3/2}$  level. With an instrumental resolution of 10 Å, this leads to a minimum detectable value of the Einstein B coefficient of about  $10^3 \text{ cm}^3 \text{ sec}^{-2}$ . For the sake of comparison, the value of B for this transition in Nd glass is about  $2 \times 10^3 \text{ cm}^3 \text{ sec}^{-2}$ . No conclusions can be drawn from this comparison because of the large inaccuracy in the measurement of the Nd concentration, as discussed above. The primary purpose in attempting to observe absorption lines was, first, to see if there was any evidence at all of the presence of Nd and, second, to obtain information on the energy level structure of  $\text{Nd}^{3+}$  in GaAs. However, the above estimates of the minimum detectable B coefficients had to be made in order to see if they were reasonable values.

### Luminescent Diode Fabrication

Luminescent diodes were fabricated from the single crystal Nd doped GaAs using the following procedure:

1. Finger lap and etch to clean. Etch consists of three parts 90-10 ( 90 percent  $\text{HNO}_3$  - 10 percent  $\text{HCl}$  ) and two parts distilled water. When the etch is made up, it is allowed to stand for two hours. When these conditions are fulfilled, the etch remains about 10 microns per minute.
2. Diffuse in sealed capsule with four zinc pellets at  $900^\circ$ . Diffusion time: 5 minutes plus 3 minutes warm-up. Each zinc pellet weighs 1 mg.

3. Finger lap .0025" from bottom side.
4. Evaporate gold-tin ( 50 percent each ) on bottom side.
5. Evaporate gold-cadmium on top side ( i.e., on zinc diffused side ). Alloy at 450°.
6. Dice to .050" x .050".
7. Place wax dot on the top of each square. Approximate diameter of wax dot: .01 - .02".
8. Dope in aqua regia one minute.
9. Etch three minutes in three parts 90-10, two parts distilled water to form mesas.
10. Remove wax dot and clean in trichlorethylene followed by methanol.

#### Emission Measurements

Emission measurements of the Nd doped diodes were made in a Perkin-Elmer Model 12-G grating spectrophotometer using a Dumont 6911 photomultiplier as a detector. The detector was cooled by passing cold N<sub>2</sub> vapors across the photocathode in order to reduce the dark current. Figure 1 shows a typical emission curve in the wavelength region 1.0 to 1.1  $\mu$  from a diode made from the single crystal material. This peak is not seen in the emission from undoped diodes, and was considerably weaker in the emission from the diodes made from polycrystalline Nd doped material. The emission was viewed from a direction roughly parallel to the junction, i.e., from the edge of the mesa.

It is seen that the whole peak is almost 100 Å wide but there is a narrower portion which is only about 300 to 400 Å wide. The fractional linewidth for this narrower peak is thus roughly the same as the fractional linewidth of the main GaAs emission line at about 8400 Å ( not shown in Fig. 1 ). Therefore, if the lifetime for the 1.07  $\mu$  emission in Fig. 1 is appreciably longer than for the main GaAs emission, and if the efficiency can be made large enough at room temperature, the 1.07  $\mu$  emission line is a potential candidate for use in a room temperature laser. Lifetime measurements must be made, both to aid in the positive identification of the 1.07  $\mu$  line and to evaluate its potentiality for laser use.

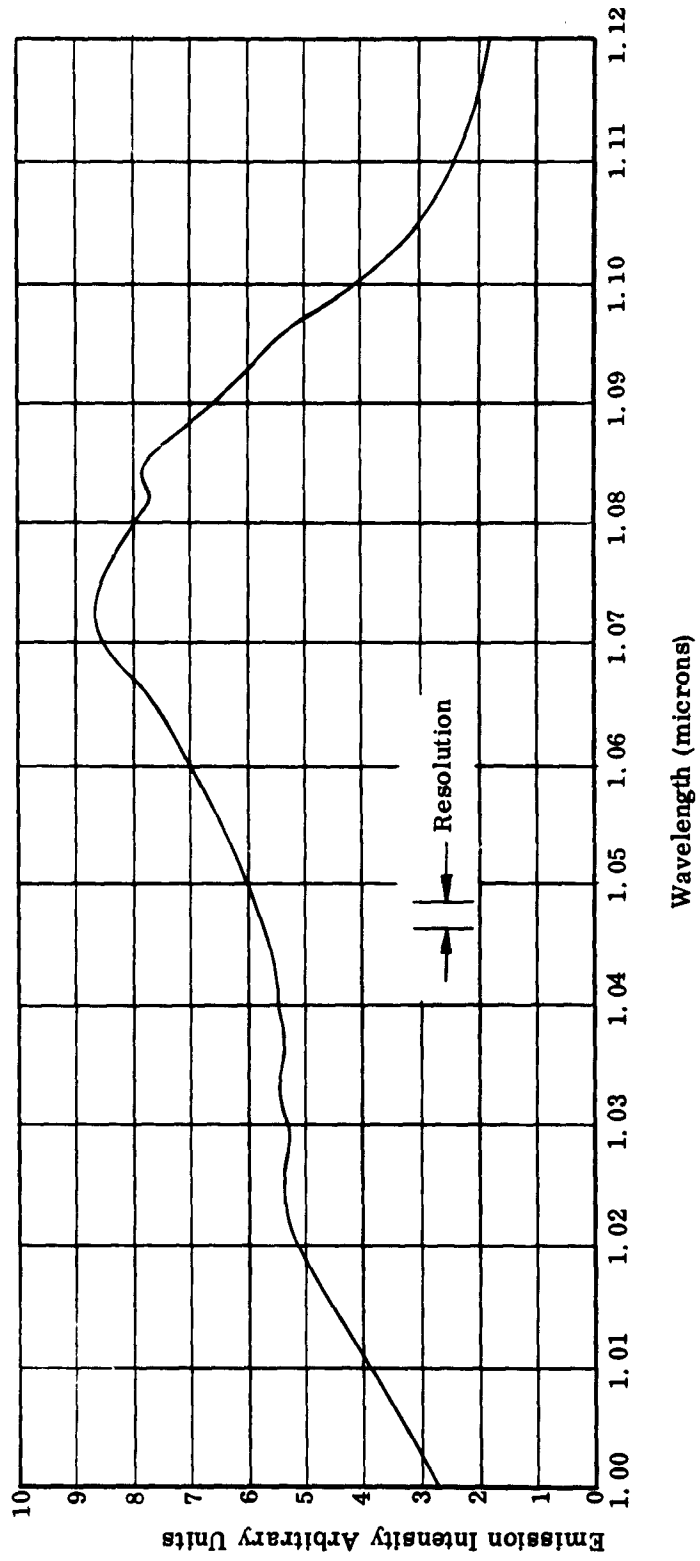

Fig. 1 - Emission of Nd doped GaAs diode at 77 deg K.

## STUDIES OF LASER DIODES

Besides the studies on Nd doped GaAs, we are also studying the characteristics of undoped GaAs laser diodes. The purpose of this part of our program is to become familiar with undoped laser diodes so that we will have a basis for comparing the performance of future rare earth doped diodes.

### Laser Diode Fabrication

Laser diodes are prepared using the following general techniques. The basic material used is n-type GaAs which either has no intentional dopants, or is doped with Se or Te for high conductivity. Slices about 0.5 mm thick are then lapped on flat glass plates with 1000 grit powder. They are then polished on a beeswax lap in a slurry of water and Linde "A" powder, washed in deionized water and cleaned ultrasonically in trichlorethylene. A p layer is then formed over the entire sample by diffusion of Zn. For this process the sample is placed in a sealed, prebaked, evacuated, fused quartz ampule together with a solution of a few percent of Zn in Ga and heated in an electric furnace controlled to within  $\pm 5$  deg C for several hours. After the samples are removed the diffusion depth is measured and the surfaces are cleaned by a rapid exposure to the following cleaning etch: 3 parts of a 10 percent solution of HF in HNO<sub>3</sub>, 2 parts H<sub>2</sub>O. In order to make a contact to the p surface, a layer of 99 percent Au, 1 percent Cd is then evaporated onto the sample to a thickness of about 0.5  $\mu$ , and then alloyed at 450°C. The p side opposite the contact is then lapped off so that the n material is exposed. The crystal orientation is originally chosen so that the junction is in a (111) plane. Since GaAs can be cleaved along (110) planes, it is possible to prepare good quality optical surfaces for the laser ends by cleaving. Thus, strips about 1 mm wide are cleaved from the sample. Then pieces about 0.25 mm wide are sawed from these strips so that the sawed surfaces are about 1 mm long and are perpendicular to the cleaved surfaces. The result is illustrated in Fig. 2. The n side of the diode is then alloyed to a Au-Sn plated transistor header and a pressure contact made to the p surface. A photograph of a completed diode is shown in Fig. 3 and a current-voltage characteristic of a typical diode is shown in Fig. 4.

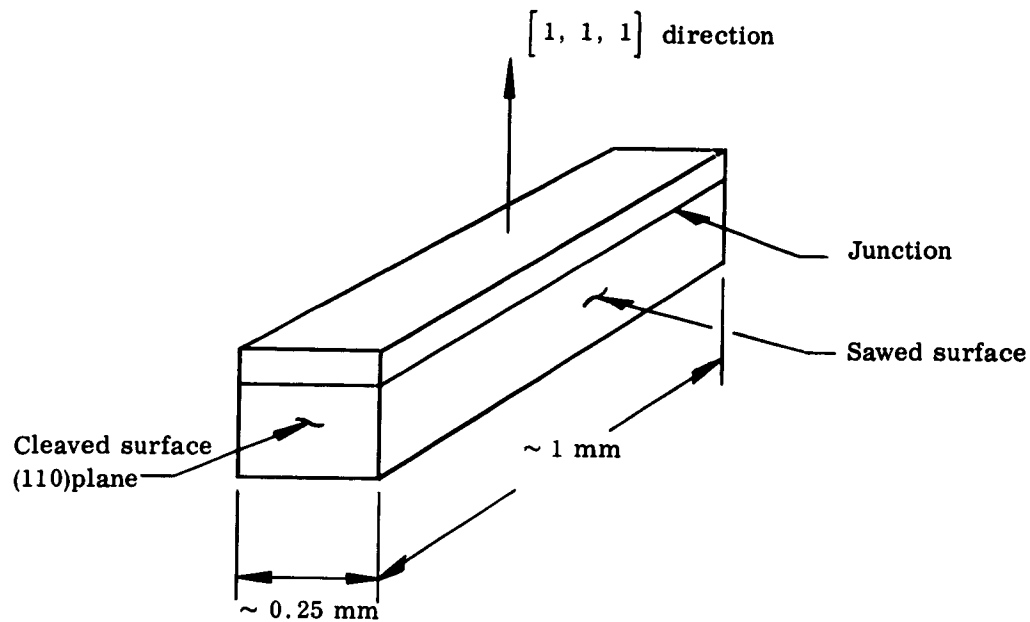

Fig. 2 - Geometry of laser diode.



Fig. 3 - Microphotograph of GaAs laser diode. The pressure contact to the top (p) surface is not shown.

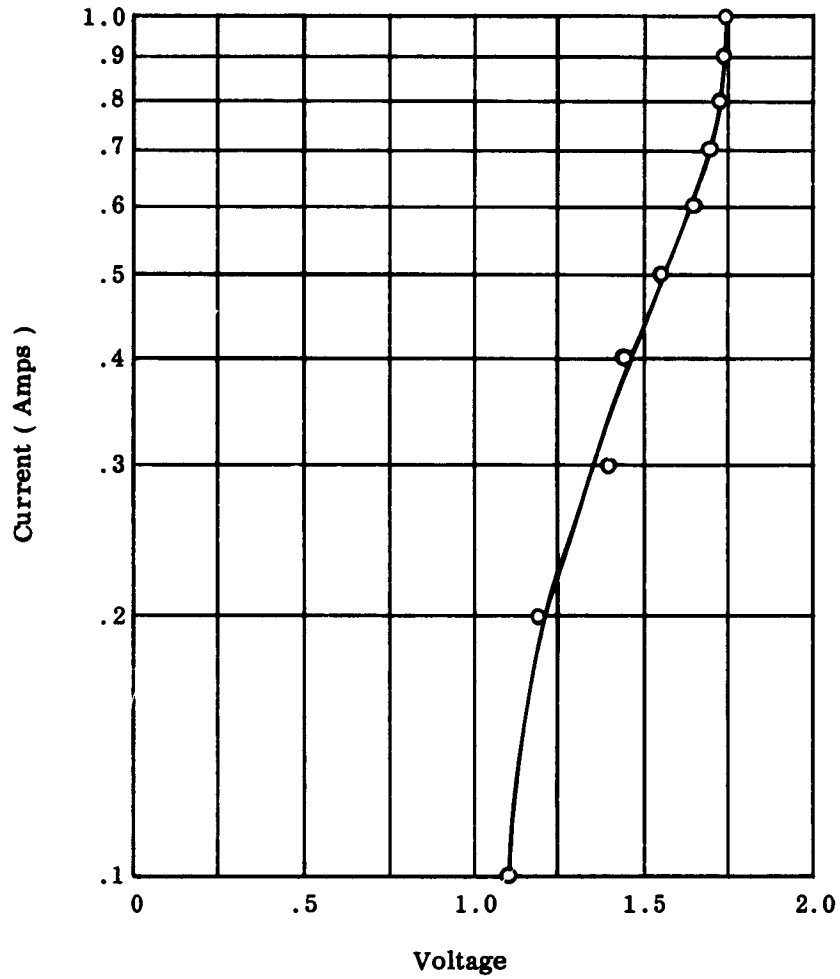

Fig. 4 - Current-voltage characteristic of laser diode.

### Emission From Laser Diode

Measurements of the emission from a laser diode have been made in the following manner. An RCA 7102 photomultiplier has been fitted with a liquid N<sub>2</sub> cryostat as sketched in Fig. 5. This is a very simple but effective type of cryostat to make and it has the further advantages that the loss rate of liquid N<sub>2</sub> is small with no vacuum required. The cryostat consists of a block of polystyrene foam into which two holes have been bored so that they intersect and form a right angle. One of the holes is a snug friction fit for the photomultiplier, while the other provides a reservoir for liquid N<sub>2</sub>. A polystyrene foam cover rests on top of the cryostat and also holds a teflon rod which supports the diode in front of the photocathode. Thus both the diode and the photocathode are held at liquid N<sub>2</sub> temperature.

A similar cryostat is used when the photomultiplier is used for a detector in the spectrophotometer. In this case, another hole is bored in the side of the cryostat and a window is fitted over it so that light can enter from the side. In order to prevent frosting of the window, the whole apparatus then fits into a compartment which is flushed continuously with dry N<sub>2</sub> gas.

When the apparatus in Fig. 5 is used, the diode is pulsed at 60pps with pulse widths of 0.5 to 1  $\mu$ sec. The output of the photomultiplier is amplified in a phase sensitive pre-amplifier before being further amplified and send to a pen recorder.

Figure 6 is a graph of the photomultiplier output as a function of peak diode current for a diode fabricated as described in the beginning of this section, and similar to the one in Fig. 3. For peak currents between 0.6 amp and about 2 amp, the output varies approximately as the seventh power of the peak current. At the lower currents, the superlinear behavior is interpreted to be due to the onset of laser action with the concurrent increase in brightness of the emitting diode. When threshold is exceeded far enough, the laser light becomes sufficiently directional that the photomultiplier cathode intercepts essentially all of the beam. Then the output should be linear, as it is observed to be at the higher currents.

The diode referred to in Fig. 6 failed before spectral measurements of the output could be made. Such measurements will be made on similar diodes in order to confirm the existence of laser action.



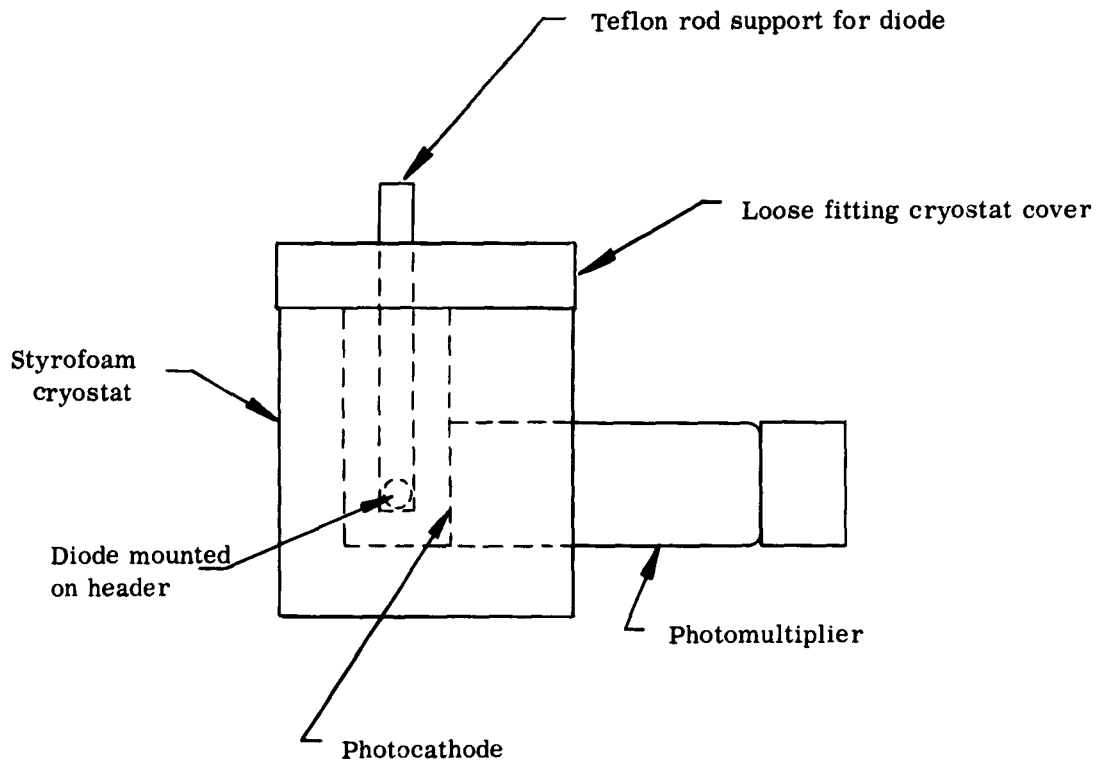
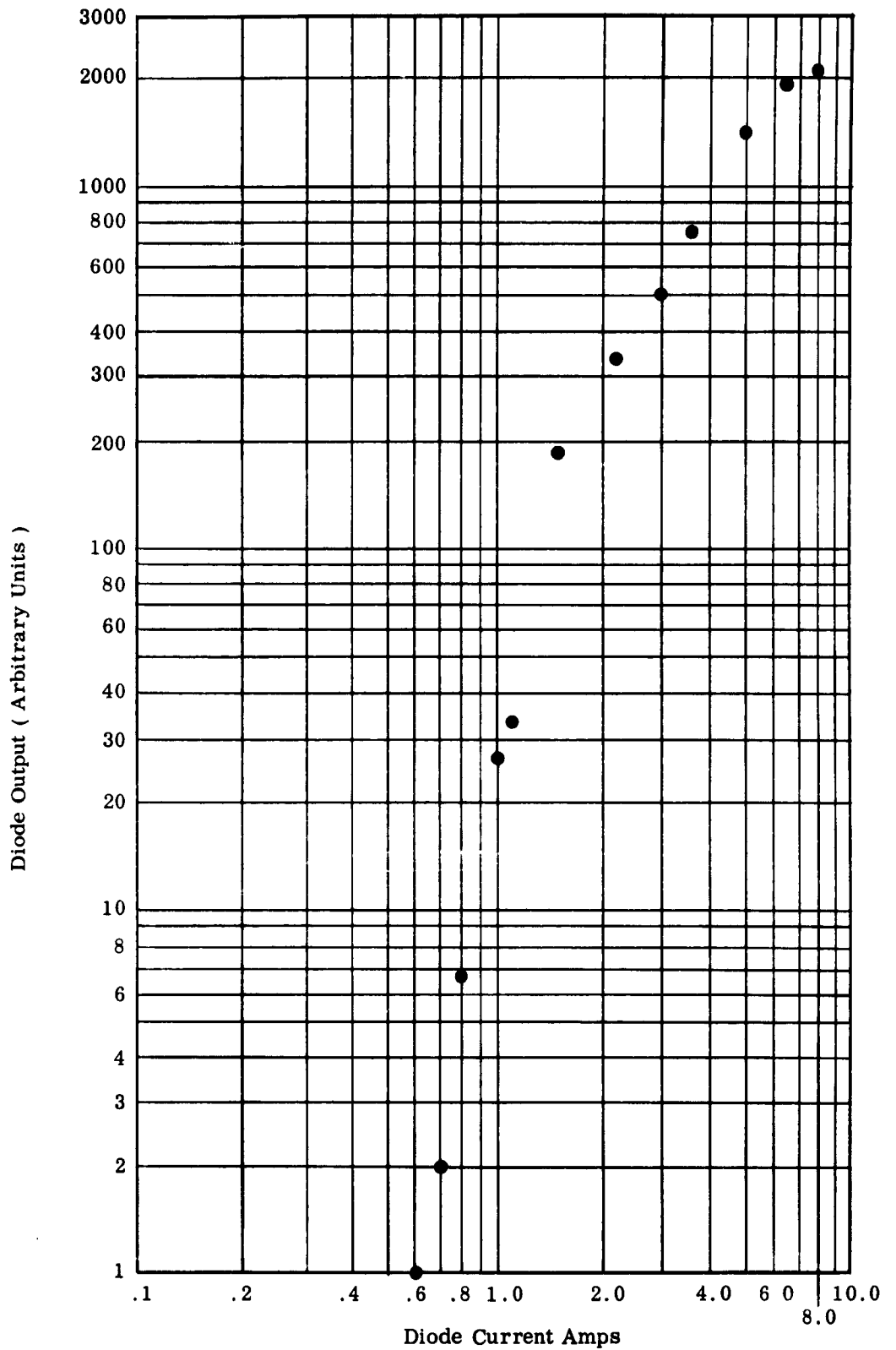

Fig. 5 - Sketch of apparatus used for cooling the photo-multiplier cathode and the diode in liquid  $N_2$ . The cone angle subtended by the photocathode is about 60 degrees.



11704

Fig. 6 - Emission vs current for GaAs laser diode.

## CONCLUSIONS

We have measured emission in the wavelength range between 1.0 and 1.1 $\mu$  from diodes made from GaAs lightly doped with Nd. This emission is likely to be due to the presence of Nd ions since it is not seen in undoped GaAs. The present small fraction of total light emitted in the Nd lines must be increased if practical laser diodes are to be made from this material. Two possible methods for doing that are to increase the concentration of Nd, and to increase the probability of Nd excitation by using a host lattice which provides a better resonance with the Nd absorption bands. Both of these techniques may be necessary. The first may be possible by doping by diffusion rather than during crystal growth. The second may be possible by the use of Ga (As, P) alloys rather than GaAs.

Two recent developments in the study of II-VI compounds are of great interest because of their applicability to injection lasers. It has been found possible<sup>1</sup> to dope ZnS heavily with Tm and to observe strong, narrow-line emission which can be attributed to the Tm ions. Also, the injection of minority carriers into CdS from metal contacts through tunnel barriers has been recently demonstrated.<sup>2</sup> The difficulty in making p-n junctions in II-VI compounds is a great handicap to their use in injection lasers, so the use of tunnel injection may remove the injection problem. For that reason all of the rare earth doped II-VI compounds discussed in our original proposal should be subjected to intensive study. It appears that they can be doped very heavily with rare earths so that emission from the rare earth sites can be quite efficient. Also the II-VI compounds have large band gaps so that a large variety of dopants are possible, as discussed in our original proposal.

## RECOMMENDATIONS

A study of GaAs and Ga (As, P) alloys doped with Nd by diffusion should be conducted in order to optimize the conditions for maximum efficiency of radiation from Nd ions, and lifetimes for the 1.07  $\mu$  line should be measured. Rare earth doped II-VI compounds should be considered. Studies should continue on the characteristics of undoped GaAs laser diodes.

## REFERENCES

- <sup>1</sup> R. C. Jaklevic, D. K. Donald, J. Lambe and W. C. Vassell; Appl. Phys. Lett. 2, 7 (1963).
- <sup>2</sup> S. Ibuki and D. W. Langer; Appl. Phys. Lett. 2, 95 (1963).

DISTRIBUTION LIST - Contract No. AF 33(657)-8917

<u>Copies</u>	<u>Activities At Wright-Patterson AFB</u>
1	ASAPRL ( Library )
1	ASAPT
1	ASRE
1	ASRCT
1	ASRCPT ( Mr. Wittebort )
1	ASRNET ( Dr. W. Knecht )
1	ASRNEM-1 ( L. Lawrence )
	<u>Other Dept. of Defense Activities</u>
	<u>Air Force</u>
1	Air Force Cambridge Research Laboratories L. G. Hanscom Field Bedford, Massachusetts
1	Air Force Systems Command ( RDRRP ) Andrews Air Force Base Washington 25, D. C.
1	Rome Air Development Center ( Document Library RAALD ) Griffiss Air Force Base New York
	<u>Navy</u>
1	U. S. Naval Research Laboratory Attn: Dr. George Abraham Code 5266 Washington 25, D. C.

Copies

Army

1  
Commanding Officer  
U. S. Army Signal Research and Development Lab.  
Attn SIGRA/SL-PFM  
J. F. Armata  
Fort Monmouth, New Jersey

1  
Commanding Officer  
U. S. Army Electronics Research and Development Lab.  
Warfare Vision Branch  
Attn. Arthur Hask  
Fort Belvoir, Virginia

Other U S. Government Agencies

2  
Advisory Group on Electron Devices  
Attn Harry Sullivan  
346 Broadway, 8th Floor  
New York 13, New York

10  
ASTIA ( TISIA )  
Arlington Hall Station  
Arlington 12 Virginia

1  
Director of Nation Security Agency  
Attn C3141 ( RM 2C087 )  
Fort George G Meade Maryland

1  
Dr. A. Yamakawa  
Electro-Optical Systems Inc.  
300 North Halstead Avenue  
Pasadena, California

1  
Scientific and Technical Information Facility  
P. O. Box 5700  
Bethesda, Maryland  
Attn NASA Representative ( S-AK/DL )

Copies

1

Texas Instruments Inc.  
Attn: Dr. R. E. Johnson  
P.O. Box 5474  
Dallas 22, Texas

ADDITION - As of 24 May 1963

1

AFCRL  
Solid State Sciences Laboratory  
Attn: CRVP ( C. E. Ryan )  
L. G. Hanscom Field  
Bedford, Massachusetts