

UNCLASSIFIED

AD 404 097

*Reproduced
by the*

DEFENSE DOCUMENTATION CENTER

FOR

SCIENTIFIC AND TECHNICAL INFORMATION

CAMERON STATION, ALEXANDRIA, VIRGINIA



UNCLASSIFIED

NOTICE: When government or other drawings, specifications or other data are used for any purpose other than in connection with a definitely related government procurement operation, the U. S. Government thereby incurs no responsibility, nor any obligation whatsoever; and the fact that the Government may have formulated, furnished, or in any way supplied the said drawings, specifications, or other data is not to be regarded by implication or otherwise as in any manner licensing the holder or any other person or corporation, or conveying any rights or permission to manufacture, use or sell any patented invention that may in any way be related thereto.

63-3-

404 097 404097

CATALOGUE ASTIA

AS AD 404097

INTERIM ENGINEERING REPORT
 for
 PROTOTYPE HIGH POWER CIRCULATOR

This report covers the period
 20 January 1962 to 20 April 1963

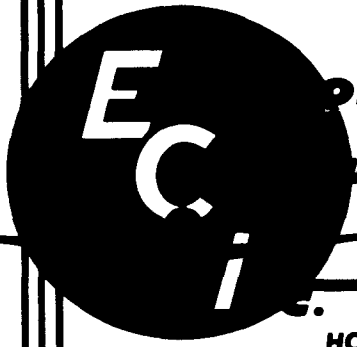

ONIC
UNICOMUNICATIONS

HOME OFFICE--ST. PETERSBURG, FLORIDA

RESEARCH DIVISION
1830 YORK ROAD
TIMONIUM, MARYLAND

DDC
 RECEIVED
 MAY 26 1963
 1963

INTERIM ENGINEERING REPORT
for
PROTOTYPE HIGH POWER CIRCULATOR

This report covers the period
20 January 1962 to 20 April 1963

Electronic Communications, Inc.
Research Division
1830 York Road
Timonium, Maryland

May 10, 1963

Navy Department Bureau of Ships Electronics Division

Contract No. NObsr-87394
Project Serial No. SF 0010205 ST 6158

ABSTRACT

The prototype High Power Y-Circulator has been completed as required by the specifications of this contract. The circulator package was delivered to the Chesapeake Bay Annex of the Naval Research Laboratory where it was tested for high power handling capabilities. The results of these tests are included in this report.

Although the circulator package includes a solid state limiter as outlined in the contract, work is continuing on a ferroelectric limiter which would be useful for powers in excess of the present "state of the art" limiters.

An extension in time has been granted by the Bureau of Ships for this contract so that work might continue on the development of the said limiter. The expiration date for this extension is 30 June 1963.

TABLE OF CONTENTS

	<u>Page</u>
ABSTRACT	i
1. PURPOSE	1
2. GENERAL FACTUAL DATA	1
2.1 <u>Background</u>	1
2.2 <u>Measurement Procedures</u>	2
2.3 <u>References</u>	2
2.4 <u>Definition of Symbols</u>	2
2.5 <u>Identification of Technical Personnel</u>	2
3. DETAIL FACTUAL DATA	3
3.1 <u>Circulator Performance</u>	3
3.2 <u>Ferroelectric Limiter</u>	3
4. CONCLUSIONS	4
5. PROGRAM FOR NEXT INTERVAL	4

LIST OF ILLUSTRATIONS

	<u>Page</u>
Figure 1 - High Power Measurement Set Up	5
Figure 2 - Dielectric Loaded Parallel Plane Transmission Line	6

1. PURPOSE

Through the successful development of an experimental high power Y-circulator⁽¹⁾ in the UHF region has come the need for a device more compatible in size to the equipment with which it will be used. The purpose of this contract is to modify the existing experimental model into a unit which will be suited for mounting in a standard 19" relay rack. Emphasis will be placed on compactness and simplicity of operation.

2. GENERAL FACTUAL DATA

2.1 Background

The circulator enclosure, electro-magnet and power supply have been mounted in a standard 19" relay rack which measures 47 1/2" high by 22" deep. The controls necessary for the adjustment of circulator performance are mounted on a front panel. The cooling system is installed just below the circulator.

High power tests were performed at the Naval Research Laboratory (Chesapeake Bay Annex) on the prototype circulator. The power level of the transmitter was gradually increased to its maximum output. At .466 mw there was a high voltage arc-over in the coaxial transition at the input to the circulator. This malfunction was due to a sharp edge on the center conductor of the transition. The faulty component was returned to the company for modification, which consisted mainly in having the sharp edge simply "rounded off". As a further precaution to any further breakdown in this region, the transition was "charged" with a high dielectric strength gas such as Sulfur-Hexafluoride (SF_6). After this modification the circulator tests were continued with satisfactory results.

Some large signal tests were made on a preliminary design of a ferroelectric limiter. These tests showed very little response to the application of high power. A new structure and new material are now being considered.

2.2 Measurement Procedures

The set up for the measurement of the performance of the prototype high power Y-circulator is shown in Figure 1. The transmitter output was monitored by means of a directional coupler at the input to the circulator. A high power dummy load was connected to the antenna port of the circulator through another directional coupler. This monitored the transmitter signal coming through the circulator's low loss path.

The power coming out of the isolated port could be monitored through the limiter or through a directional coupler. This was accomplished by means of a coaxial switch which could select either output. The directional coupler position was used when first monitoring the power out of the circulator's isolated port. Once it was determined that the isolation was at least twenty db, the coaxial switch could then be turned to the limiter position. This would insure that the limiter was not being overloaded.

2.3 References

- (1) "Final Development Report for Low Frequency Broad-band Ferrite Components," 30 June 1961, Contract No. NObsr-77602, Index No. NE 050500/S. T. 17.4

2.4 Definition of Symbols

mw - megawatt

RF - radio frequency

kw - kilowatt

2.5 Identification of Technical Personnel

		Hours
J. C. Wiltse	Manager Microwaves	5
Marvin Cohn	Research Scientist	38
A. F. Eikenberg	Senior Engineer	427

3. DETAIL FACTUAL DATA

3.1 Circulator Performance

A warm-up period of approximately fifteen minutes is required before the circulator is ready for operation at high power. The ferrite must be at a certain temperature to insure optimum performance. This temperature can be read directly off a meter located on the front panel of the cooling unit. For the circulator to provide at least 20 db isolation the temperature should read 90°F ($+5^{\circ}$, -1°). Should these values be exceeded the magnetic field would have to be readjusted for maximum isolation.

An SPS/17 Radar Transmitter manufactured by the General Electric Company was used as the source of high RF power. Unfortunately, this source could provide only .640 mw of energy at 1920 watts average power. It was hoped to use a source capable of producing 1 mw of peak power; however, the data obtained with this source at 219.5 Mc is as follows:

Peak Input Power	Average Input Power	Isolation (Including Limiter)	Insertion Loss
0.640 mw	1.920 kw	70.5 db	0.6 db

The limiter used in the circulator package for these tests has a maximum peak power rating of 10 kw. This places a limit on the VSWR of the antenna used with the circulator. An antenna with a VSWR of 1.23 or less must be used with a transmitted signal of 1 mw in order to keep the limiter from burning out. A dummy load with a VSWR of 1.05 was used in these tests.

3.2 Ferroelectric Limiter

A limiter using a ferroelectric ceramic was fabricated in this reporting period. Figure 2 shows a drawing of the configuration used. This structure is a parallel plane waveguide propagating a surface wave. By applying an electric field transverse to the direction of propagation, the dielectric constant of the ferroelectric material changes in a non-linear way. An applied dc electric field gives a

considerable change in dielectric constant; however, with a high RF electric field there was very little activity. Another structure has been constructed and will be tested between this report and the final report due 30 June 1963.

4. CONCLUSIONS

The high power Y-circulator has been tested and delivered to the Chesapeake Bay Annex of the Naval Research Laboratory. High power tests were performed and satisfactory results obtained with a peak power of .640 mw. Further investigations into a ferroelectric limiter have not produced an optimum working model; however, more work is being done to improve this device. Company funds as well as the remaining contract costs are supporting this work.

5. PROGRAM FOR NEXT INTERVAL

The remaining time will be spent developing a ferroelectric limiter and writing a final report.

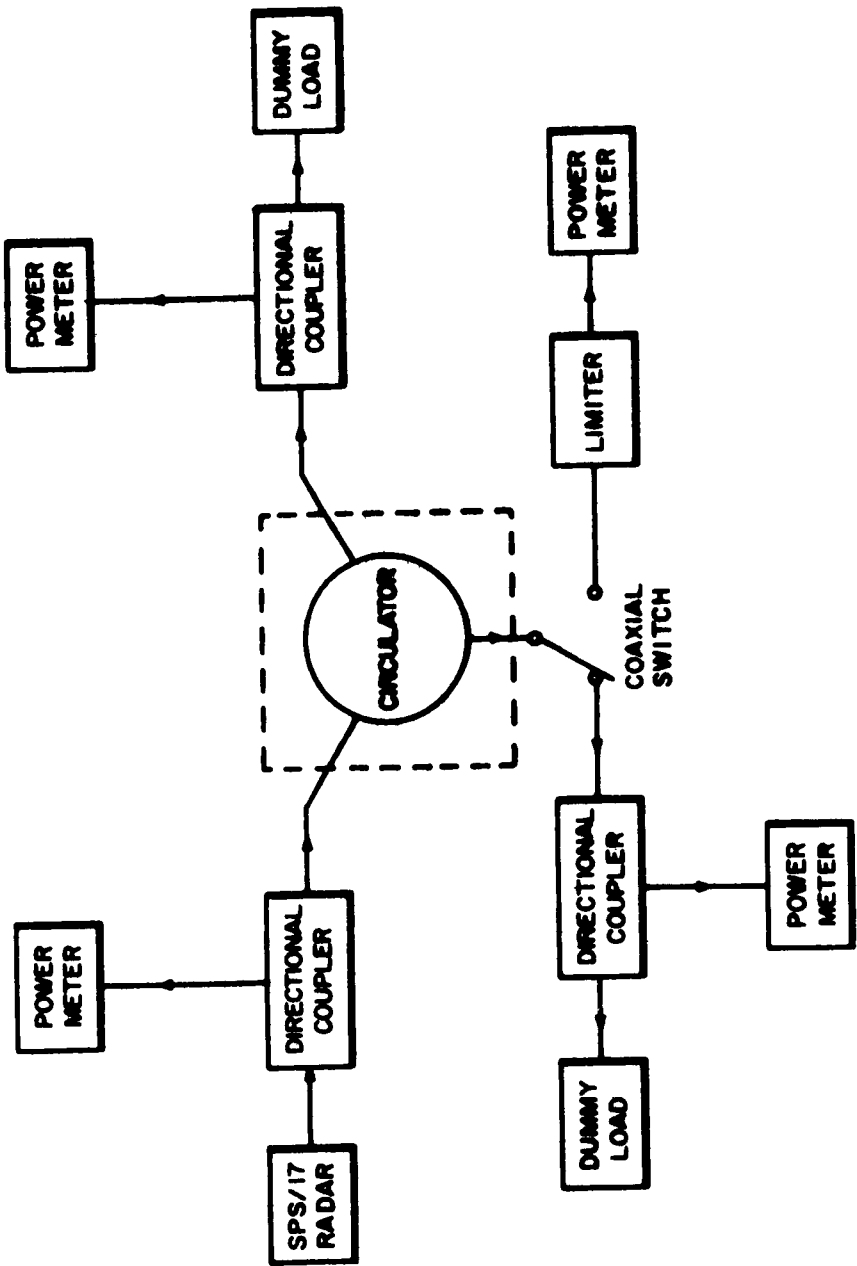

FIG. 1 - HIGH POWER MEASUREMENT SETUP

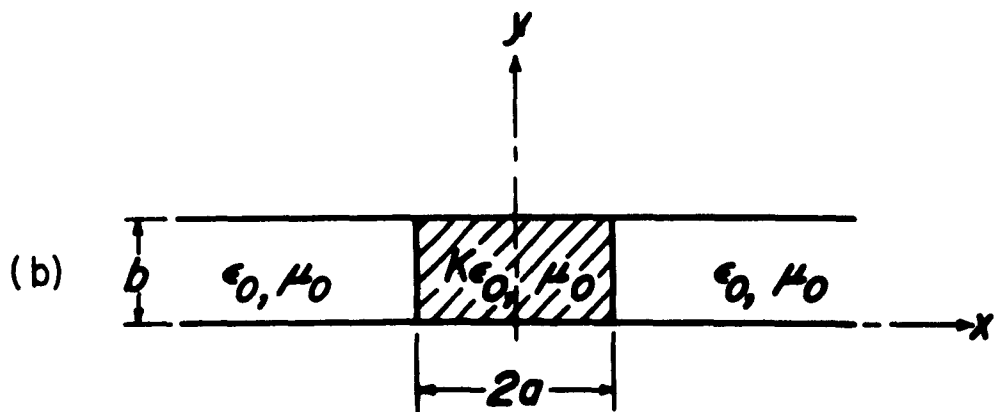
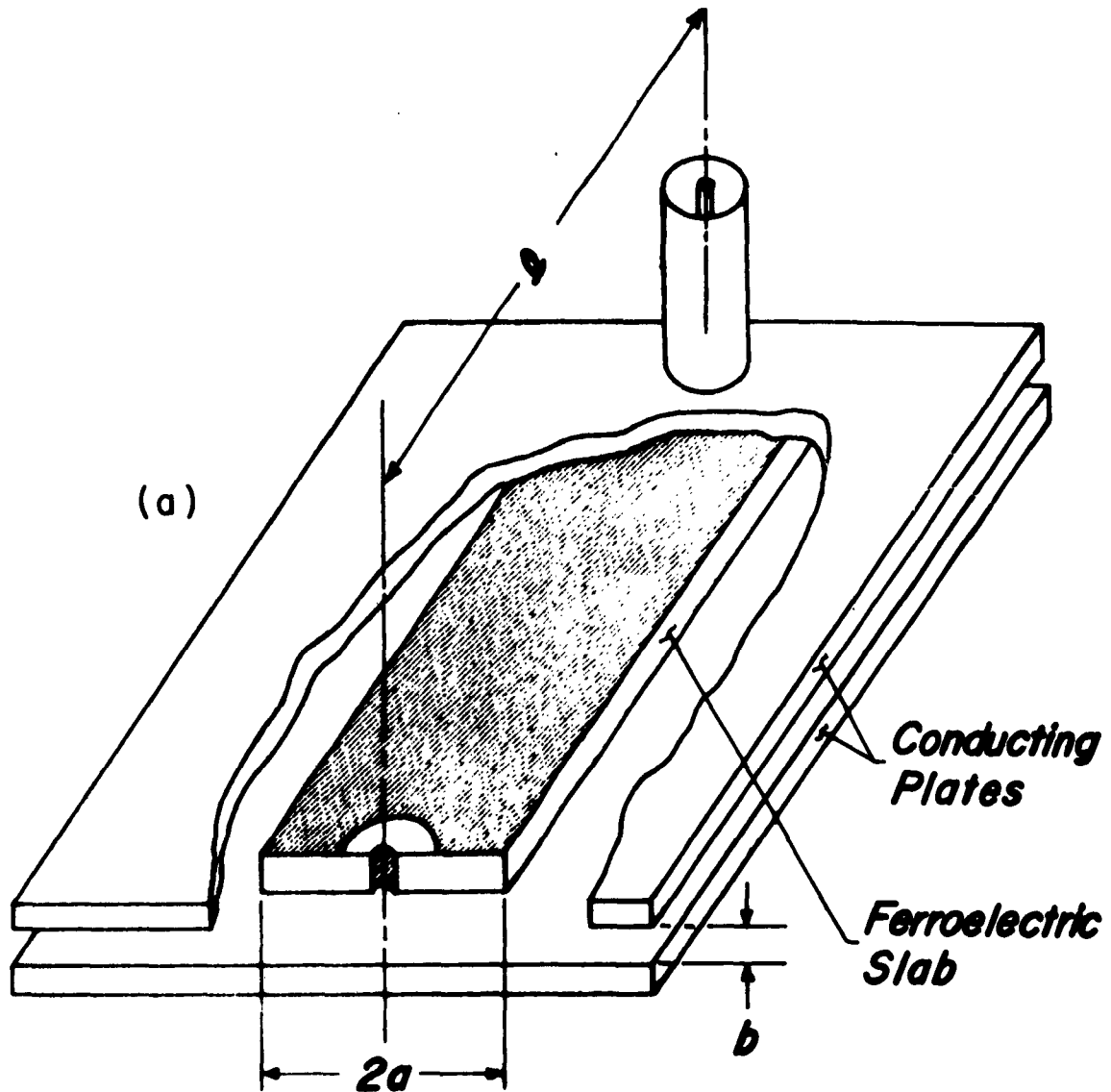

FIG. 2 - (a) CUTAWAY VIEW OF THE FERROELECTRIC LOADED PARALLEL-PLANE TRANSMISSION LINE (b) CROSS-SECTIONAL VIEW OF THE PARTIALLY DIELECTRIC LOADED PARALLEL PLANE TRANSMISSION LINE.