

**UNCLASSIFIED**

---

---

**AD 402 751**

*Reproduced  
by the*

**DEFENSE DOCUMENTATION CENTER**

FOR

**SCIENTIFIC AND TECHNICAL INFORMATION**

**CAMERON STATION, ALEXANDRIA, VIRGINIA**



---

---

**UNCLASSIFIED**

NOTICE: When government or other drawings, specifications or other data are used for any purpose other than in connection with a definitely related government procurement operation, the U. S. Government thereby incurs no responsibility, nor any obligation whatsoever; and the fact that the Government may have formulated, furnished, or in any way supplied the said drawings, specifications, or other data is not to be regarded by implication or otherwise as in any manner licensing the holder or any other person or corporation, or conveying any rights or permission to manufacture, use or sell any patented invention that may in any way be related thereto.

63 3 5

AMRL-TDR-63-10

402751

**CAPILLARY ACTION LIQUID OXYGEN CONVERTER  
FOR  
WEIGHTLESS ENVIRONMENT**

TECHNICAL DOCUMENTARY REPORT NO. AMRL-TDR-63-10

January 1963

Life Support Systems Laboratory  
6570th Aerospace Medical Research Laboratories  
Aerospace Medical Division  
Air Force Systems Command  
Wright-Patterson Air Force Base, Ohio

Contract Monitor: I. H. Lantz  
Project No. 6373, Task No. 637302

(Prepared under Contract No. AF33(616)-8185  
by  
Duane E. Hinds  
John Cleveland  
The Bendix Corporation, Pioneer-Central Division  
Davenport, Iowa)

**Best  
Available  
Copy**

## NOTICES

When US Government drawings, specifications, or other data are used for any purpose other than a definitely related government procurement operation, the government thereby incurs no responsibility nor any obligation whatsoever; and the fact that the government may have formulated, furnished, or in any way supplied the said drawings, specifications, or other data is not to be regarded by implication or otherwise, as in any manner licensing the holder or any other person or corporation, or conveying any rights or permission to manufacture, use, or sell any patented invention that may in any way be related thereto.

Qualified requesters may obtain copies from ASTIA. Orders will be expedited if placed through the librarian or other person designated to request documents from ASTIA.

Do not return this copy. Retain or destroy.

Stock quantities available at Office of Technical Services, Department of Commerce, \$0.75.

### Change of Address

Organizations receiving reports via the 6570th Aerospace Medical Research Laboratories automatic mailing lists should submit the addressograph plate stamp on the report envelope or refer to the code number when corresponding about change of address.

## FOREWORD

This report has been prepared by The Bendix Corporation, Pioneer-Central Division, under Contract Number AF33(616)-8185. The work described in this report was conducted under the sponsorship of the 6570th Aerospace Medical Research Laboratories, Aerospace Medical Division, Wright-Patterson Air Force Base, Ohio. The contracting monitor was Mr. I. H. Lantz of the Life Support Systems Laboratory, 6570th Aerospace Medical Research Laboratories, Wright-Patterson Air Force Base, Ohio. This work was conducted under Project Number 6373 "Equipment for Life Support In Aerospace", Task Number 637302. At Pioneer-Central, project leaders were Duane E. Hinds and John Cleveland and Mr. Robert Hansen, Senior Engineer, Cryogenic Engineering, provided administrative supervision. The report summarizes the project which was started on May 1, 1961 and concluded on August 25, 1962.

Manufacturer's Type Number for the liquid oxygen converter is X1612634, Serial No. 208001E.

#### ABSTRACT

A 25-liter, capillary-action liquid-oxygen converter has been fabricated to incorporate all the components required to provide a completely operational, self-contained system to supply breathing oxygen in a weightless environment.

The converter design of functional components and the principle of operation has combined the forces of surface tension, wetting, and capillary action of liquid oxygen to provide adequate forces to insure satisfactory operation of the system during space environments. These forces will provide for the expulsion of liquid oxygen under standard conditions, during acceleration forces up to and including 14 G, and in the weightless condition.

The report includes all the test data and results of the complete development program and the physical arrangement required for the capillary action converter system. The testing which could be accomplished in the laboratory gave every evidence that the design concept is satisfactory for weightless operation.

#### PUBLICATION REVIEW

This technical documentary report has been reviewed and is approved.

*Wayne H. McCandless*  
WAYNE H. McCANDLESS  
Chief, Life Support Systems  
Laboratory

## TABLE OF CONTENTS

	PAGE
INTRODUCTION	1
DESIGN STUDY	2
A. Build-up Circuit	2
Capillary Tubes	3
B. Wetting Materials	3
C. Venting the Container	3
D. The Gaging System	4
E. Concepts which were discarded	4
FABRICATION OF PROTOTYPE	7
A. Description of Container	7
B. Description of Converter	9
C. Description of Components	10
OPERATION OF SYSTEM	10
TESTING AND PERFORMANCE DATA	14
CONCLUSIONS	17
	17

## LIST OF FIGURES

FIGURE		PAGE
1	VENTING CONCEPT	3
2	GAGING SYSTEM SCHEMATIC	5
3	GAGING SYSTEM CIRCUIT	5
4	COMPLETE CONVERTER	7
5	CONVERTER SCHEMATIC	8
6	VENT NETWORK	9
7	CONVERTER ASSEMBLY	11
8	EVAPORATION GRAPH	13



## INTRODUCTION

The unusual environmental conditions encountered in manned orbital and interplanetary space flight make necessary the development of certain devices and equipment to sustain human life. Perhaps the most critical of this equipment will be that which provides breathing oxygen. In present day manned aircraft, the breathing oxygen supply is usually stored in the liquid form because of the weight and space advantages in this method. However, an airborne liquid-oxygen converter works on the principle of maintaining a pressurized gas blanket over the liquid. The occasion of a pressure differential forces the liquid out the liquid orifice; hence, to an evaporating coil - as the user demands. The liquid, having the gravity contributed characteristic of weight, is constantly exposed to the liquid exit orifice. If, with absence of a weight influence, the liquid may locate randomly, then liquid supply becomes a matter of chance, i. e., determined by the occasion of external forces.

Therefore, the primary problem with a liquid oxygen system in a gravity of force equilibrium environment is random orientation of the liquid due to its weightless characteristic. The problem is apparent in partially filled vessels as opposed to full vessels, and further, the problem exists not only for liquid oxygen, but for all liquids. (See Ref. 2.) "Experiments have been conducted at the Lewis Research Center in a drop tower with a glass sphere test container. The glass test unit was approximately 2-1/2 inches in diameter and 40 percent filled with ethyl alcohol in a 1-G field. During the near weightless condition simulated by the drop test, the liquid vapor surface will establish a spherical shape. Unfortunately this liquid sphere has no preferred location and could easily come to rest over the container inlet and outlet. The concept of being able to position the liquid and vapor in a container through utilization of the principle of minimum surface energy has been verified in experiments in the drop tower."

This report concerns the development of a liquid oxygen converter system embodying one method of operation in a weightless environment. The unit involves the use of capillary action to provide the buildup and vent function necessary for operation both on the ground and under weightless conditions in space. The major problems were:

1. Control of liquid orientation.
2. Establish exit phase, i. e., liquid or gas.
3. Quantity indication.
4. Package or system weight and volume.
5. Functional reliability.
6. Functional environmental testing.

## DESIGN STUDY

There was no method of proving all the concepts used in the design study, because a weightless environment condition cannot be completely tested on a converter system in normal gravity environment. This study of a 25-liter weightless-environment converter was based on capillary action and established calculations for the condition of pressures, buildup and vent flows and the expected operating conditions of the system. A series of tests were then initiated using standard converters and equipment to prove the above calculations and from these tests the actual buildup and vent flows, capillary influence, and the system pressure drops were determined.

The primary difference between the requirements for the liquid oxygen converter described in this report and a conventional production converter as used in present day aircraft is that the new converter must function in a zero-gravity or weightless environment. The current airborne converters take advantage of gravity for maintaining head pressure, liquid flow and the proper oxygen supply operation. The function of gravity as a liquid orientation device in this design must be replaced by some other force equilibrium arrangement that will work effectively in a zero-gravity environment.

### A. Buildup Circuit

A problem was foreseen in using a self-pressurizing system to maintain the operating pressure in the converter under all conditions of positive, negative, and weightless environments. We anticipated that it would be impossible to use a conventional buildup circuit because such a circuit depends on positive gravity and the head of liquid in the container to introduce liquid into the buildup coil. Also conventional converters usually combine the function of the liquid phase pigtail to furnish liquid oxygen for both the buildup and supply circuits. Because of the required flow rates for this converter design and performance in a zero-gravity environment, two separate container pigtails were used for the buildup and supply function.

Consequently, because we could not depend on either positive gravity or a head of liquid at the buildup port, some means became necessary to force liquid from the inner container into the buildup coil where it can pick up heat, vaporize, and maintain the system operating pressure. From the design study and laboratory tests the measured flow was higher than the theoretical flow per minute required to maintain operating pressure. Therefore the figure of 0.576 cc/minute was used for the prototype development. To do this a circuit was explored involving the use of a wetted area around the lower inner vessel to help provide liquid at the container outlet port with a series of capillary tubes leading from the inner vessel wetting area into the buildup coil. Once outside of the container a conventional warming coil, buildup valve and related circuitry can be used. This circuit working in a weightless environment will provide a usable differential pressure ( $\Delta P$ ) to overcome the various buildup circuit pressure drop.

## Capillary Tubes

Laboratory tests determined the lengths and sizes of the stainless steel tubing used for the capillary buildup coil. Preliminary results for gas and liquid pressure drops showed a relationship between capillary rise and viscous pressure drop would exist in the liquid flow part of the buildup circuit. For a given flow, the smaller capillary tube will provide the greater rise, and therefore the greater pressure rise can be translated into an improved ability to overcome pressure drops in the buildup circuit. Expected performance with the 0.576 cc/minute flow was about one inch of liquid oxygen pressure rise.

## B. Wetting and Non-Wetting Materials

During the elementary test program we hoped that some non-wetting materials could be located and explored to expedite venting of the container. A vent system made of this hypothetical material, located at the top of the inner vessel, would vent only gas during normal gravity and in weightless conditions. However, from the design study (ref. 1) and the testing of thirty materials it was apparent that no known non-wetting material which was suitable for use with liquid oxygen could be located to apply to the problem of venting the container.

## C. Venting the Container

Venting the container of gaseous oxygen during use, without the loss of liquid oxygen was the most difficult of all the design problems. For reasons of safety, it is necessary to provide overboard pressure relief of the system, and in the event of overboard relief, the oxygen must be gaseous instead of liquid because a much lesser mass per unit volume is relieved. The critical area of this problem is at delivery rates less than 660 cc/minute STP, with the present state-of-the-art evaporation heat losses, the pressure within the container will rise to the relief valve setting and vent the system as the boiled-off gas overbalances the delivery flow rate.

The relief valve port at the top of a conventional container will suffice under conditions of normal gravity but would be entirely unsatisfactory under zero gravity since the liquid would cover the entire inner surface of the container. As explained in Ref. 2, the NASA, Cleveland, Ohio test data showed

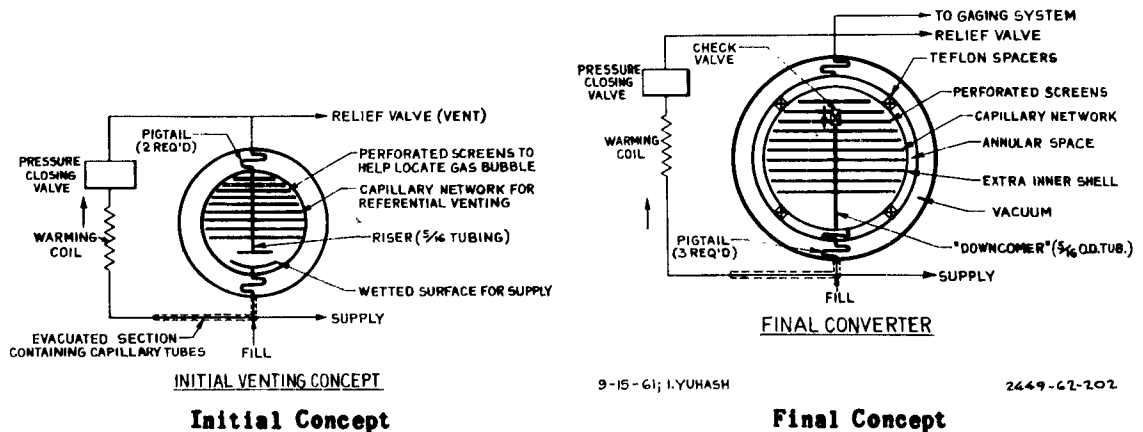

FIGURE 1 - VENTING CONCEPT

the liquid to form a globular shape with the gas forming one large bubble remaining in the center of the spherical shape.

To overcome this problem, a capillary venting network running through the entire inner container was used, with the dimensional spacing small enough to pick up the gas bubbles wherever they occur during the weightless condition, as shown in Figure 1. Calculations indicated that a given length of capillary tube would flow considerably more volume of gas than liquid for the same initial pressure drop. The liquid flow would be  $1.025 \times 10^{-2}$  cc/minute and the gas flow under the same conditions would be  $1.57 \times 10^{-1}$  cc/minute thus giving 15.3 parts gas to one part liquid on a volumetric basis. Therefore, a preferential selection of gas over liquid would prevail, and the initial vented mixture would be two-phase which would vent through the down-comer, into the annular space between the inner container and its liner. The large surface and good thermal contact of this annular space would vaporize the remaining liquid before leaving the container pigtail, vent line and exit through the relief valve as in a conventional unit.

#### D. The Gaging System

The gaging system components, which were secondary to the converter system, have been deleted as part of the capillary action converter per Supplement of the Exhibit dated 20 July 1962 because of the excess weight and space envelope. This gaging system was to measure the contents of liquid oxygen remaining in the container by measuring a quantity of oxygen which when introduced into the container would result in a fixed pressure rise of the container pressure.

During the design study phase of the subject contract, special attention was given to improving the gaging system as outlined in the proposal. However, no new or novel methods were discovered. Therefore, the proposed system would have had a space envelope of approximately 17" x 17" x 9" with a calculated weight of 15 lbs. 10 oz. The system would have consisted of two (2) solenoid valves, 15 liter accumulator, gear drive motor, rack and pinion with the piston and cylinder, magnetic brake and a pressure ratio switch.

Two solenoid valves were to isolate the container from the converter system during the gaging pulse while a 15 liter capacity accumulator was to be provided for breathing oxygen during the 15 second gaging cycle. Figure 2 shows the schematic of the proposed system in which the piston and cylinder inject the test volume of oxygen into the container. This piston was to be driven by an electric gear motor whose pinion engaged a rack which was cut into the piston rod. The volume of oxygen would be measured by a potentiometer coupled to the drive pinion. The pressure rise as measured by a pressure ratio switch, which was necessary because of the 30 psig pressure variation within the system, would stop the motion of the piston and apply the magnetic brake to the potentiometer shaft.

A power requirement of 28V DC, 8 amp. was to be required for the proposed circuit as shown in Figure 3. Finally, since the gaging system could have possibly altered the basic converter design somewhat it was intended to build a bread-board of the gaging system in conjunction with the capillary action unit. Since this portion of the program was not completed before its cancellation, full evaluation of the gaging system cannot be made.

#### E. Some Concepts Which Were Shelved or Discarded

a) A flexible vent tube was explored to "locate" the gas bubble and expedite venting it. Since no buoyancy exists in weightless environment, the tube would

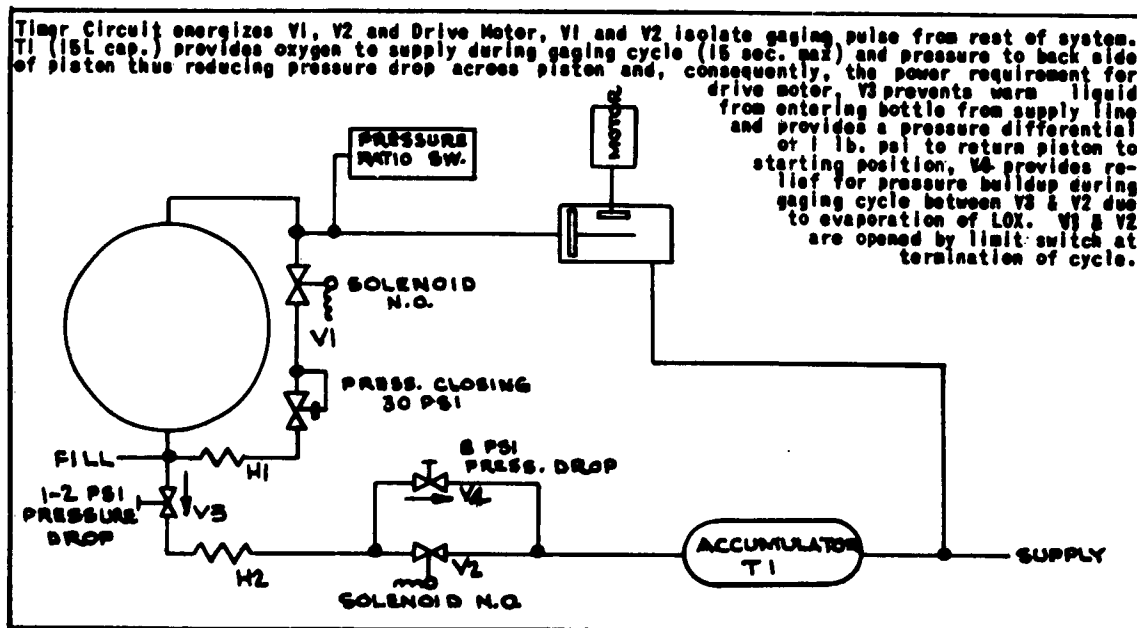

FIGURE 2 - GAGING SYSTEM SCHEMATIC

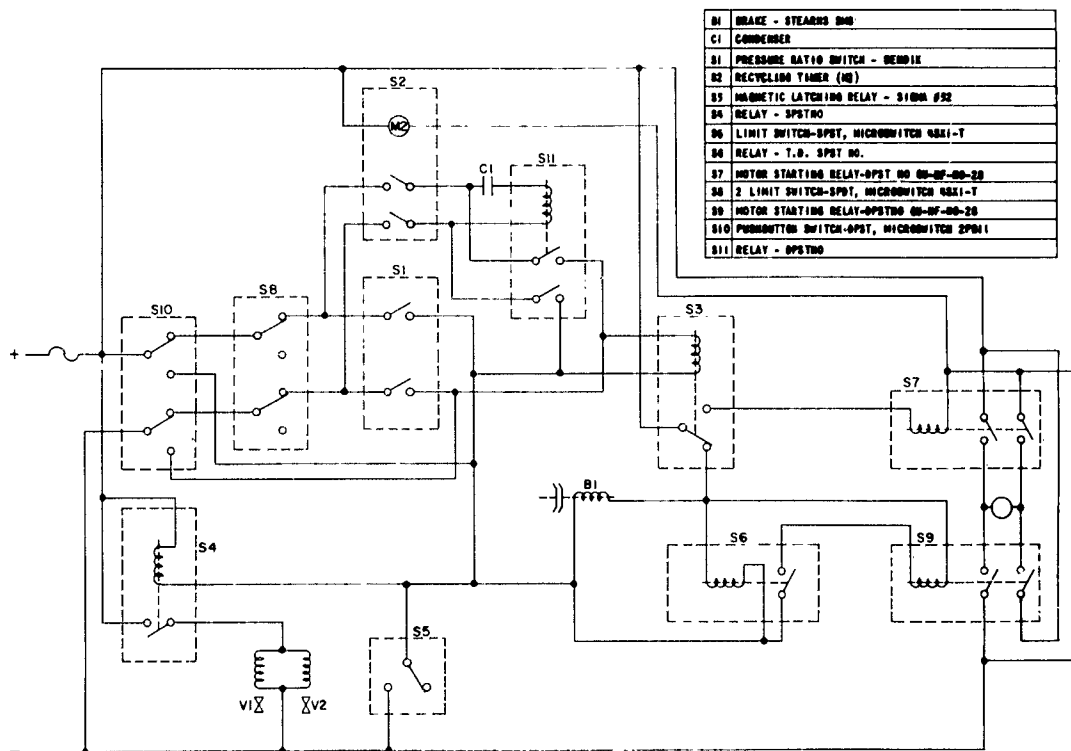

FIGURE 3 - GAGING SYSTEM CIRCUIT

have to be located by surface tension forces. This tube would have to be very flexible, yet would have to operate at cold. The idea was finally discarded as impractical.

b) Various "separators" to separate the gas from the liquid were explored. Mechanically driven ones are not suitable, but fixed vanes or separators might be useful in the annular space or elsewhere in the circuit. These would almost certainly be made of a wetted material (from the results of our tests), and their use will have to be considered further.

c) A heat exchanger was considered where the vented mixture would exchange with the buildup flow in a counterflow arrangement. This approach has an obvious shortcoming. Even though the flows are of the same order of magnitude, these flows occur at different times, and no practical way appeared where the buildup flow could be used to convey heat to the vent circuit to boil off liquid before it left the container. The heat exchanger was considered as a sort of concentric pigtail to take the place of the regular pigtail that connects the top of the inner and outer shells. This idea was finally discarded.

d) Repeatedly, consideration is given to testing this unit upside down at normal g to see if it would vent gas instead of liquid, buildup successfully, or both. Since there is no known way to test the proposed unit except to put it into some weightless condition flight path, it would be an enormous asset to be able to make it operate inverted. So far, there have always been "stumbling blocks" to prevent inverted operation.

e) "Percolation" is a phenomenon which appears frequently in converters. It is an unstable flow condition whereby liquid appears higher in a gravitational field than a steady state check would indicate. This usually results in a two-phase pulsing spray of liquid and gas which will appear at the end of the buildup or supply line. Under these conditions the liquid may rise as high as the top of the dewar. To make the circuit percolate, the liquid must be vaporized by heat input, so that the gas formed will propel liquid ahead of itself by a reaction force against the liquid in the dewar. An attempt was made to use this behavior to enhance the performance of the buildup circuit. However, as the mass of liquid in the dewar changes, the percolation is reduced.

In the buildup circuit being considered in this design, the capillary rise is obtained best if the buildup line is insulated from the container to the valve. Since liquid flow is required for capillary action, it appears that a design using percolation might be inconsistent with a design in which liquid flow is maintained to utilize capillarity. Consequently, the use of percolation was shelved.

f) A "Pneumatic Oscillator" has been used with partial success at Bendix to augment the performance of a buildup circuit. In this operation, liquid is trapped between check valves just as it leaves the container. This liquid vaporizes, at least in part, causing a pressure rise and some gas flow to the supply line, followed by a pressure drop below system pressure. This pressure rise and fall repeats itself at a frequency determined by the dynamics of the system, involving pneumatic spring rates, system volumes, heat inputs, and valve characteristics. The behavior is extremely complex and not yet fully analyzed. Pressure peaks of 55 and 90 psig have been measured in a nominal 70 psig system. The higher peaks are "siphoned off" by using spring loaded check valves, and these peak pressures are fed to the buildup circuit, and the system pressure accordingly built up. Since this concept has not been developed as far as buildup method utilizing capillarity outlined in this report, it was temporarily shelved until more knowledge is obtained.

## FABRICATION OF PROTOTYPE

The prototype converter fabrication was routine once the container development program was completed. The unit consists of the container, isolation mounting system, suitable valves, and piping to pressurize the liquid and deliver it to the system. Conventional external related circuitry and components were used where practical as shown in Figure 4. As covered previously in the report, the gaging system has been deleted as a component of the prototype.

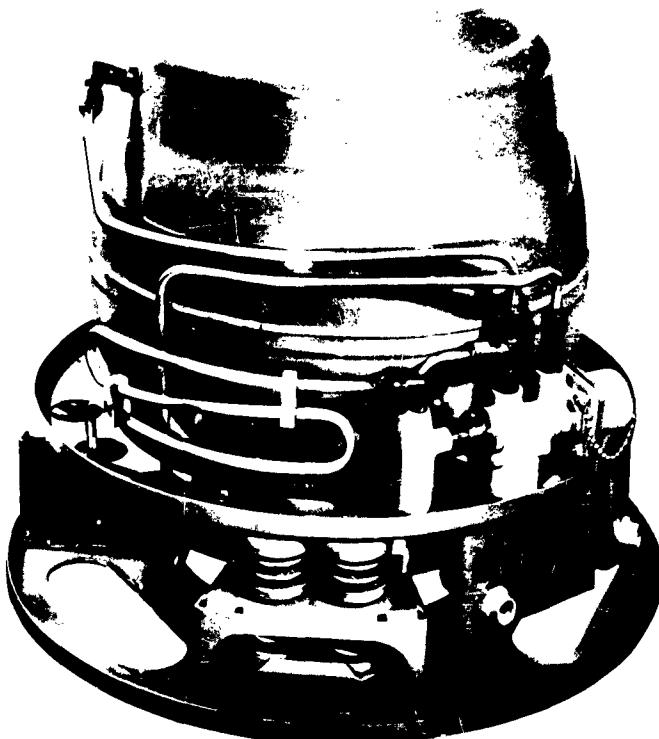

FIGURE 4 - THE COMPLETE CONVERTER

### A. Description of Container

The development of a system to function in a weightless environment resulted in most of the design changes occurring within the container portion of the system. With the capillary action venting network and buildup circuit development completed the assembly of the container followed the present state-of-the-art. However, all of the schedule program delays and setbacks occurred in this area of fabrication. The major problem encountered was on the inner container liner design when several outside vendors hesitated to bid on its fabrication. This was because of the design complexity, and the indentations for the Kel-F spacers. Finally after a redesign simplification a vendor was selected. However, the progress of the inner container was held up for approximately four weeks because of difficulties experienced by the vendor in furnishing a satisfactory liner due to the close tolerance on the diameter dimension with respect to the inner container shells. An

additional problem was experienced with the inner container shell alignment for welding until a special weldment jig was fabricated. Also special fixtures were required for the buildup capillary tubes and the venting network assemblies which were the most difficult parts to fabricate.

The container consists of an inner and outer shell of heliarc welded stainless steel. The inner container is suitably suspended within the outer container by six Kel-F bumpers mounted on the container fill and vent pigtails with a very high vacuum maintained in the space between. Referring to Figure 5; the inner container assembly consists of an inner liner surrounding 150 various lengths of capillary

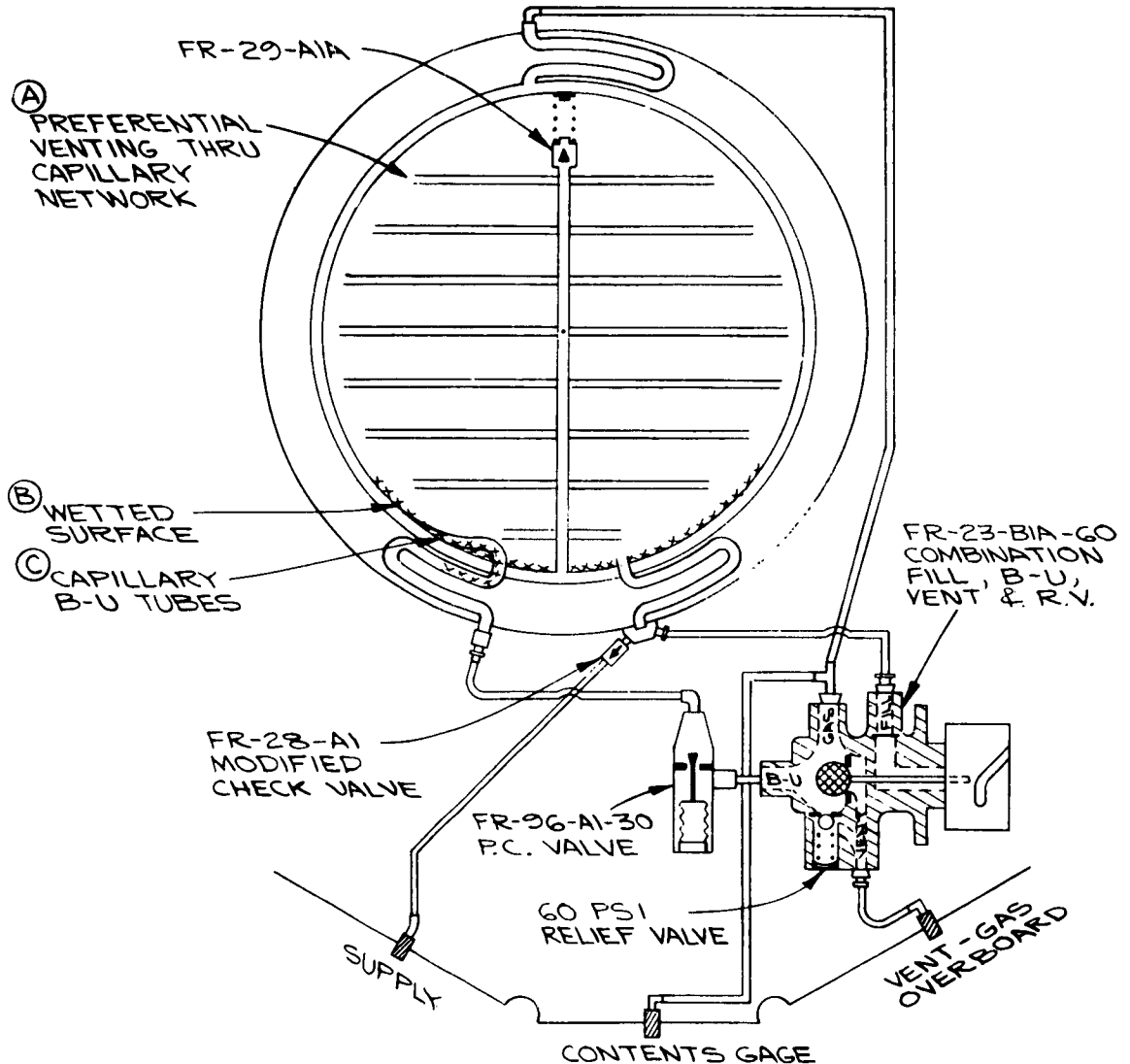
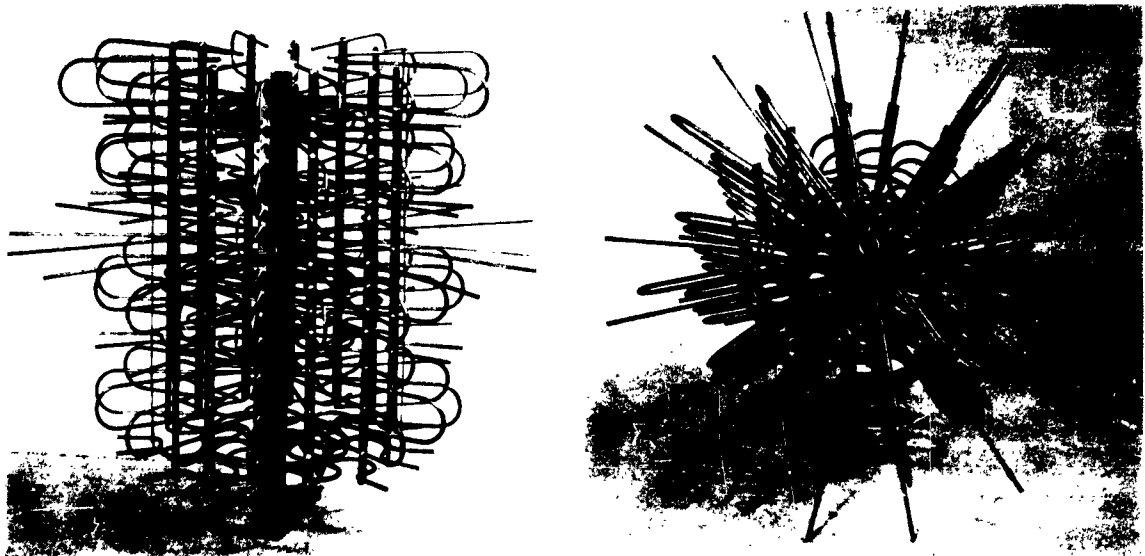

FIGURE 5 - CONVERTER SCHEMATIC



tubes (A) in a Christmas tree type network (Figure 6) for preferential venting of gaseous oxygen. This inner liner is suspended by 40 Kel-F spacers and also includes 250 capillary buildup tubes of various lengths (C) which are interlaced within the wetting blanket (B). The wetting blanket is a fiberglass wool wicking approximately one inch thick which has been compressed to .250 inch and held in place by 24 random spaced stainless steel fasteners attached to the liner. A check valve with a 2 psig pressure drop was installed at the top end of the down-comer to allow the container to be filled on the ground. This was required because



Front View

Top View

FIGURE 6 - VENT NETWORK

the capillary network was designed to flow only the required vent flow rate at the maximum working pressure of the converter system. From previous experience the flow rate of the flashed gas when filling a warm container with liquid oxygen would be more than the capillary network could handle. Therefore, during the fill operation the check valve will open and allow an additional flow of 100 LPM of STP gaseous oxygen.

#### B. Description of Converter

The converter meets the general requirements of the subject exhibit as to envelope size, weight, capacity and function for use in a weightless environment based on capillary action of liquid oxygen for operation. The self-contained system includes the automatic control and relief valves to pressurize the liquid oxygen and deliver it to the supply port. It involves the use of capillary action to provide the buildup circuit and capillary selection of vent gas in preference to liquid oxygen for the vent functions necessary to operate under zero gravity conditions.

The system envelope is approximately 18 inches in height and 20 inches in diameter with a total empty weight of 40-1/2 pounds which includes the container, mounting system, components, and associate hardware and plumbing. This unit has a capacity of 25 liters of liquid oxygen, operates at a nominal pressure of 30 psig, and will deliver oxygen at a pressure between 30 to 60 psig at a normal delivery rate of 15 LPM when used in conjunction with an adequate heat exchanger. The unit is bottom mounted with all plumbing connections being located at a common manifold panel at the base of the converter except the installation of the fill valve. So that the liquid oxygen filler connection is easily accessible for servicing, the fill valve is located on an accessory bracket on the upper mount panel. Figure 7 shows the converter assembly, outline and schematic details.

### C. Description of Components

The converter envelope is built around a shock mounted system fabricated by Robinson Technical Products. The Met-L-Flex mounting system consists of a base element for mounting to the aircraft, an upper tray assembly for attachment of the container, and interconnecting cushions for vibration isolation with suitable reinforcement to withstand the acceleration loads. However, the vendor unexpectedly departed from the specification for the container mounting location which delayed the program approximately three weeks.

The pressure closing valve used on the above system was a modified Bendix type number FR-96-A1-30. This is a normally open valve in the buildup circuit which closes upon the desired operating pressure being reached. For this application the valve spring was redesigned to close at 30 psig.

The Bendix type number FR-23-B1A-60 valve used on this unit is a combination component which permits the filling, buildup to operating pressure, relieving excess pressure, and venting the system, without manual operation other than the connecting or disconnecting of the filler nozzle. In the event that the converter is to be topped-off or refilled when pressurized, the connecting of the filler valve will automatically vent the converter and the unit may then be topped-off when the pressure within the container is at or below the filling pressure.

The system also included a five pound differential check valve, Bendix type number FR-28-A1A, installed between the container liquid outlet port and the manifold supply connection. This valve prevents the return of warm oxygen into the container assembly once it is converted into gas beyond the converter envelope.

## OPERATION OF SYSTEM

### A. General Description

The description on system operation will include the preliminary instructions for the evaluation test program. The converter is filled by connecting a filler nozzle (Air Force 55D3795 or equivalent which has had the check valve removed) (\*See tech. description note B\*) to the converter filler port, FR-23-B-1A and pressurizing the cart storage tank to 50 psig to insure a continuous flow of liquid oxygen into the container. Liquid oxygen flows into the inner container, absorbs heat and gasifies until the unit reaches approximately lox temperature. The gas is vented through the 150 preferential capillary tubes and the FR-29-A1A check valve when a P of .5 psig is reached, and flows out through the downcomer, around the inner liner to the container vent port.

Upon disconnecting the filler valve, the system is automatically placed in the buildup position; i.e., the gas side or phase of the container is put into direct



communication with the liquid phase of the container. The liquid flows out of the container through 260 capillary tubes into the buildup coil, gasifies, flows through the pressure closing valve into buildup side of the combination valve and back into the gas phase of the container. This sequence continues until a pressure of 30 psig is reached at which time the pressure closing valve closes, stopping communication between the gas and liquid phase of the container. When this predetermined pressure has been reached, the converter is ready for operation and a supply of oxygen is available in the supply port. This pressure will be constant as long as there is liquid in the converter and it is being used because of the 260 capillary tubes interlaced within the wetting blanket which will contain lox under all conditions of weightless environment.

When the liquid flows out of the container into the buildup coil as explained above, it also flows past a check valve from the wetting blanket and directly into the supply system port. Beyond the converter envelope and within a suitable heat exchanger, the liquid absorbs heat and is converted into a gas. The delivery rate of 15 lpm will be maintained as long as there is liquid in the converter and it is being used because of the wetting blanket on the inner liner lower surface. If the converter is at operating pressure and is not used for some time (6 to 24 hours), the pressure within the container will increase. This is due to heat from the atmosphere being conducted and radiated into the container and in turn warming the liquid causing the pressure to be increased. When the liquid oxygen is not used before the pressure reaches 60 psig, the pressure relief valve will vent the excessive gaseous oxygen overboard.

#### B. Fill

The capillary action converter must be filled with a source pressure of approximately 50 psig through a minimum length of transfer hose, and an Air Force filler nozzle which has had the 5 pound check valve removed. This is required to insure a continuous flow of liquid oxygen into the container, and overcome the .5 pound differential check valve in the downcomer section of the inner container. The differential check valve was installed within the inner liner to prevent liquid flow into the downcomer under conditions of weightless environment. Also used during the fill operation is a valve restriction in the overboard vent port of the manifold. This is recommended to overcome the percolation effect discussed in the previous paragraph.

Methods other than the above will fail to fill the converter to capacity. For example: Use of the standard aircraft fill operation will only transfer approximately 17 pounds of liquid.

#### C. Evaporation Loss

Considerable difficulties have been encountered during the laboratory evaluation of this unit in the evaporation and standby tests. As stated on page 6, Section V of the Design Study Report, "the venting of the container during use without loss of liquid oxygen was the most difficult of the design problems". For reasons of safety it is necessary to provide overboard pressure relief of the system and during extended flight duration and very likely survival itself, the oxygen vented in the event of overboard relief must be gaseous instead of liquid since the mass per unit volume is considerably less. In standard aircraft converters, the relief or venting port is at the top of the container. This will relieve gaseous oxygen under conditions of normal gravity, but would be entirely unsatisfactory under conditions of zero gravity since the liquid would cover the entire surface of the container. Under these conditions, the relief or vent port would be covered with liquid and vent it overboard.

To overcome this problem the differential check valve was installed at the inlet of the capillary network and surrounded by an inner liner. It was theorized that preferential selection of gas over liquid would prevail, and the vented mixture would be two phase. This was based on calculations of the capillary tube area, the ratio of densities, and the pressure drop between the liquid and gaseous oxygen within the container. We believe this assumption to be feasible in zero gravity, because the liquid oxygen will reorientate to assume the spherical shape of the inner container, whereas, the gas will combine into one large bubble at the center of the mass.

However, in normal gravity the heat input into this type of container causes nucleate boiling where small vapor bubbles will form next to the surface of the inner vessel. These bubbles of gas will rise to the top of liquid surface to form vented gas. As this gas is forced through the downcomer it propels liquid ahead of itself by a reaction force.

Therefore, during the performance test program on the prototype converter the phenomenon known as "percolation" appeared within the container vent pigtail. This is an unstable flow condition within the downcomer and annular space between the liner and inner container, whereby liquid rises higher than a steady state flow condition indicates, thus causing a two phase pulsing spray in the annular space so that liquid rises as high as the top of the dewar venting this two phase oxygen.

To make the circuit percolate the liquid must be vaporized due to heat input, and the gas that is formed propels liquid ahead of itself by a reaction force against the liquid in the inner container. As the mass of liquid in the container changes, the percolation effect is reduced. Therefore, during the evaporation heat loss tests of vent and pressure this condition existed, until a greater area of capillary tubes was exposed to the gas phase over the liquid phase. This caused the excessively high pressure heat loss of approximately 30 pounds in 24 hours. (Note graph Figure 8). With the use of a restriction valve in the manifold vent port

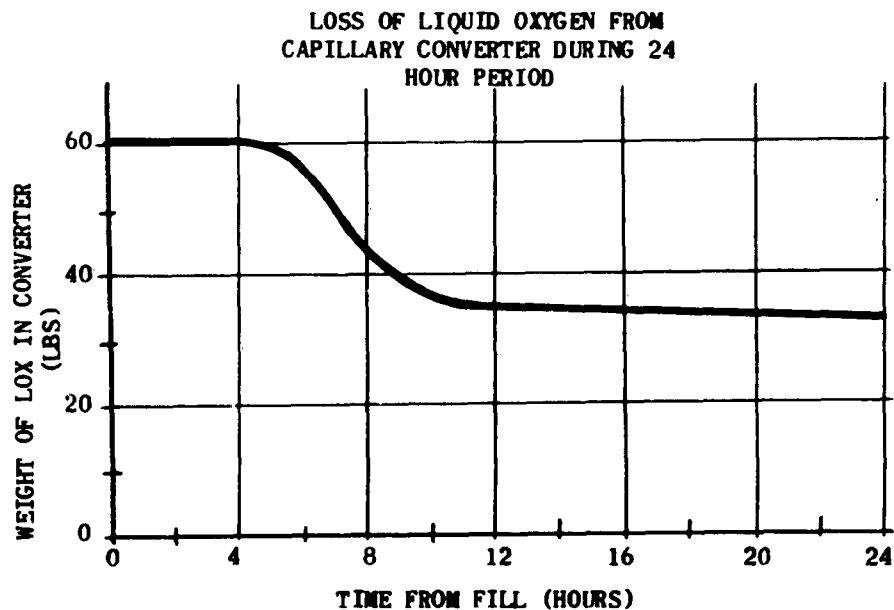

FIGURE 8 - EVAPORATION GRAPH

this loss was reduced to 17 pounds in 24 hours. This is due to the fact that the restriction created a back pressure within the vent pigtail holding the liquified gas within the inner container. This restriction was sized for a flow of 34 lpm at 20 psig.

To prove the vacuum integrity of the container the vent loss was performed in the inverted position. Thus, the container vent line was used as the fill port and the liquid line served as the vent port. In this way the inner container and its components operated as a conventional dewar. Under those conditions the vent loss in a 24 hour period was only 2-1/2 pounds.

#### TESTING AND PERFORMANCE DATA

Testing of the converter presented the real problem to the development program. Since there is no known method of proving all the concepts used in the design study and the prototype converter which was developed to function in a weightless environment the final determination of the success of the program must be made by ASD.

In order to have some indication of the soundness of the design concept the contractor has accomplished the following test program which could be conducted in the laboratory:

Actual test data on type X1612634, S/N 20001E, 25 liter, Capillary Action Liquid Oxygen Converter. The converter furnished under item three of the subject contract will conform to the following requirements of Exhibit WVRDLS 61-15 and the general performance test requirements of MIL-C-25666:

<u>Test</u>	<u>Paragraph No. Required</u>	<u>Results</u>
3.1 Examination of Product	7.0	Meets the requirements of WVRDLS 61-15
3.1.1 Provide Minimal Space Envelope		Maximum Height - 17-3/4 inches Maximum Diameter - 19-3/4 inches
3.1.2 Weight, Complete Operational, Self-Contained System		49 lbs., 4 oz.
3.2 Container	4.0	S/N E-101
3.2.1 Date of Evacuation		June 4, 1962
3.2.2 Hydrostatic Test, at 5/3 Times the Working Pressure		Pneumatic test at 60 psig without damage to container
3.3 Evaporation Loss: The loss rate shall not exceed 3 lbs. of O <sub>2</sub> per 24 hrs. during stand-by conditions.	3.0	
3.3.1 First Evaporation Loss, within 5 days after evacuation (in the vent position).		7-19-62 2.5 lbs.
3.3.2 Evaporation Loss, after 30 days from above		8-19-62 2.5 lbs.
3.3.3 Evaporation Loss, in the pressurized position		8-1-62 25.5 lbs. first 12 hrs. - See page 13. 1.5 lbs. second 12 hrs.
3.4 Capacity: The Converter shall contain 25 ± 0.5 liter of LOX under ambient condition.	5.0	a) Theoretical capacity-25 liter b) Calculated capacity-24.5 liter, 61.25 lbs.

<u>Test</u>	<u>Paragraph No. Required</u>	<u>Results</u>
3.4.1 Actual capacity during test program		24.1 liter, 60.45 lbs.
3.5 Fill Time: Shall be kept at a minimum	5.0	
3.5.1 With a source oxygen pressure of 50 psig from a 150 liter storage dewar with a minimal transfer line and manual shut-off valve.		Maximum - 10 minutes Average - 6 minutes Minimum - 4 min., 18 sec.
3.6 Operating Pressure: Under the most adverse condition shall remain between 30 and 60 psig.	3.0	The pressure closing valve is set at 30 psig.
3.6.1 Buildup Time, the time for operating pressure to reach pressure closing valve setting		60 minutes
3.7 Final Pressure Assembly Leakage Test: The complete converter with all components and tubes shall be leak checked with soap solution at a pressure of 60 psig.		No leaks
3.8 Delivery Rate: The converter shall be capable of maintaining flow rates up to 15 lpm (0°C, 760mm) with the operation pressure remaining between 30 and 60 psig.	3.0	Flow rate - 15 LPM Pressure - 30 to 40 psig Time - 4-1/2 hours
3.8.1 The loss rate (evaporation) measured during operating condition shall be zero.		At the normal 15 lpm flow rate, the container pressure slowly increases under standard conditions (gravity) from 30 psig to the relief valve Pressure of 60 psig after 9-1/2 hours.
3.9 Components: All valving required to provide a completely operational, self-contained system shall be incorporated in the converter.		
3.9.1 Pressure Closing Valve		Type no. FR-96-A1-30
3.9.1.1 Leakage across seat, at 15" H <sub>2</sub> O without bellows and spring assembly		zero
3.9.1.2 Pressure closing valve setting, pressure required to close valve		30 psig
3.9.1.3 Assembly and body leakage, at 60 psig		zero
3.9.2 Check valve		Type no. FR-28-A1-5 (modified at fitting end thd.)

<u>Test</u>	<u>Paragraph No. Required</u>	<u>Results</u>
3.9.2.1 Leakage below opening pressure at 4 psig		0.025 lpm
3.9.2.2 Flow at 7 psig		11 lpm
3.9.2.3 Leakage in check direction at 10 psig		zero
3.9.2.4 Body and assembly leakage at 30 psig		zero
3.9.3 Combination Fill, Build-up, Vent and Relief Valve		Type No. FR-23-B1A-60
3.9.3.1 Check Valve leakage at 10" H <sub>2</sub> O, 30 and 60 psig		zero
3.9.3.2 Vent port leakage at 10" H <sub>2</sub> O, 30 and 60 psig		.016 lpm
3.9.3.3 Gas port leakage at 30 psig		zero
3.9.3.4 Relief valve leakage at 50 psig		.01 lpm
3.9.3.5 Relief valve capacity at 70 psig		100 lpm
3.9.3.6 Vent and relief port leakage at 50 psig		.03 lpm
3.10 Vibration: The complete converter filled with lox shall withstand the vibration load from 0.2 to 500 cps	6.0	Test data from 25 liter converter S/N E-101 dated 4 June 1962. Test to para. 4.8.5, procedure XII, of MIL-E-5272.

<u>Plane</u>	<u>Test</u>	<u>Amplitude</u>	<u>Frequency</u>	<u>Remarks</u>
Vertical	Search	.036"-10G	.2-500 cps	
"	Resonance	.036"	14.75 cps	shock mounts
"	"	.036"	53 cps	inner container
"	"	5G	101 cps	valving
Horiz. #1*	Search	.036"-10G	.2-500 cps	
"	Resonance	.036"	9 cps	shock mounts
"	"	.036"	53 cps	inner container
"	"	10G	238 cps	mounted base
Horiz. #2*	Search	.036"-10G	.2-500 cps	
"	Resonance	.036"	8-9 cps	shock mounts
"	"	.036"	50 cps	inner container
"	"	10G	230 cps	mounted base

Note: Horiz. #1 - Plane of vibration parallel to manifold.  
 Horiz. #2 - Plane of vibration perpendicular to manifold.

3.10.1 There was no mechanical failure or malfunction due to the applied vibration.

3.11 Hot & Cold Temp.	8.0	Flow rate - 15 lpm
The converter shall function through a temperature range of -65 to +260°F.		Pressure - 30 to 40 psig
		Temp. range - -65° to +260°F
		Time of test - 6 hours at -65°F
		4 hours at +260°F



## CONCLUSIONS

The primary difference between the converter described in this report and a conventional aircraft converter is that this unit must function in a zero gravity or weightless environment. Therefore, most of the design changes have occurred in the container portion of the unit with the external system and components being similar to current aircraft converters. The testing that could be accomplished in the laboratory gave every evidence that the design concept is satisfactory for operations in weightless environment, so much so that the unit has a relatively short standby time in a normal gravity environment. This is due to the combination capillary vent network, differential check valve, and the inner liner.

---

## REFERENCES

1. Cleveland, John, Design Study - Capillary Action Liquid Oxygen Converter, September, 1961. This Design Study was submitted to WADD by Pioneer-Central to fulfill Item 2 of contract AF33(616)8185; it was approved by WADD letter ASRKMB dated 9 November 1961.
2. Silverstein, Dr. Abe, "Researches in Space Flight", The Journal of the Royal Aeronautical Society, v. 65, pp. 779-795, December 1961.

Para. 2.1.4 - Weightless Flight: reference to Figure 12, "Liquid vapor distribution in sphere during near weightless condition."

<p>Aerospace Medical Division 6570th Aerospace Medical Research Laboratories, Wright-Patterson AFB, Ohio Rpt. No. AMRL-TDR-63-10. CAPILLARY ACTION LIQUID OXYGEN CONVERTER FOR WEIGHTLESS ENVIRONMENT. Final report, Jan 63, iv + 17 pp incl. illus., tables, 2 refs. Unclassified report</p> <p>A 25-liter, capillary-action liquid-oxygen converter has been fabricated to incorporate all the components required to provide a completely operational, self-contained system to supply breathing oxygen in a weightless environment. The converter design of functional components and the principle of operation has combined the forces of surface tension, wetting, and capillary action of ( over )</p>	<p>UNCLASSIFIED</p> <ol style="list-style-type: none"> <li>Liquid Oxygen Converter</li> <li>Capillary Action</li> <li>Weightlessness</li> <li>Space Environmental Conditions</li> </ol> <ol style="list-style-type: none"> <li>AFSC Project 6373, Task 637302</li> <li>Life Support Systems Laboratory</li> <li>Contract AF 33(616)-8185</li> <li>Bendix Corporation Davenport, Iowa</li> </ol> <p>UNCLASSIFIED</p>	<p>UNCLASSIFIED</p> <ol style="list-style-type: none"> <li>Liquid Oxygen Converter</li> <li>Capillary Action</li> <li>Weightlessness</li> <li>Space Environmental Conditions</li> </ol> <ol style="list-style-type: none"> <li>AFSC Project 6373, Task 637302</li> <li>Life Support Systems Laboratory</li> <li>Contract AF 33(616)-8185</li> <li>Bendix Corporation Davenport, Iowa</li> </ol> <p>UNCLASSIFIED</p>	<p>UNCLASSIFIED</p> <ol style="list-style-type: none"> <li>Liquid Oxygen Converter</li> <li>Capillary Action</li> <li>Weightlessness</li> <li>Space Environmental Conditions</li> </ol> <ol style="list-style-type: none"> <li>AFSC Project 6373, Task 637302</li> <li>Life Support Systems Laboratory</li> <li>Contract AF 33(616)-8185</li> <li>Bendix Corporation Davenport, Iowa</li> </ol> <p>UNCLASSIFIED</p>
<p>Aerospace Medical Division 6570th Aerospace Medical Research Laboratories, Wright-Patterson AFB, Ohio Rpt. No. AMRL-TDR-63-10. CAPILLARY ACTION LIQUID OXYGEN CONVERTER FOR WEIGHTLESS ENVIRONMENT. Final report, Jan 63, iv + 17 pp incl. illus., tables, 2 refs. Unclassified report</p> <p>A 25-liter, capillary-action liquid-oxygen converter has been fabricated to incorporate all the components required to provide a completely operational, self-contained system to supply breathing oxygen in a weightless environment. The converter design of functional components and the principle of operation has combined the forces of surface tension, wetting, and capillary action of ( over )</p>	<p>UNCLASSIFIED</p> <ol style="list-style-type: none"> <li>Liquid Oxygen Converter</li> <li>Capillary Action</li> <li>Weightlessness</li> <li>Space Environmental Conditions</li> </ol> <ol style="list-style-type: none"> <li>AFSC Project 6373, Task 637302</li> <li>Life Support Systems Laboratory</li> <li>Contract AF 33(616)-8185</li> <li>Bendix Corporation Davenport, Iowa</li> </ol> <p>UNCLASSIFIED</p>	<p>UNCLASSIFIED</p> <ol style="list-style-type: none"> <li>Liquid Oxygen Converter</li> <li>Capillary Action</li> <li>Weightlessness</li> <li>Space Environmental Conditions</li> </ol> <ol style="list-style-type: none"> <li>AFSC Project 6373, Task 637302</li> <li>Life Support Systems Laboratory</li> <li>Contract AF 33(616)-8185</li> <li>Bendix Corporation Davenport, Iowa</li> </ol> <p>UNCLASSIFIED</p>	<p>UNCLASSIFIED</p> <ol style="list-style-type: none"> <li>Liquid Oxygen Converter</li> <li>Capillary Action</li> <li>Weightlessness</li> <li>Space Environmental Conditions</li> </ol> <ol style="list-style-type: none"> <li>AFSC Project 6373, Task 637302</li> <li>Life Support Systems Laboratory</li> <li>Contract AF 33(616)-8185</li> <li>Bendix Corporation Davenport, Iowa</li> </ol> <p>UNCLASSIFIED</p>
<p>liquid oxygen to provide adequate forces to insure satisfactory operation of the system during space environments. These forces will provide for the expulsion of liquid oxygen under standard conditions, during acceleration forces up to and including 14 G, and in the zero-gravity condition. The report includes all the test data and results of the complete development program and the physical arrangement required for the capillary action converter system. The testing which could be accomplished in the laboratory gave every evidence that the design concept is satisfactory for zero-gravity operation.</p>	<p>UNCLASSIFIED</p> <ol style="list-style-type: none"> <li>D. E. Hinds J. Cleveland</li> <li>In ASTIA collection</li> <li>Aval fr OTS: \$0.75</li> </ol> <p>UNCLASSIFIED</p>	<p>UNCLASSIFIED</p> <ol style="list-style-type: none"> <li>D. E. Hinds J. Cleveland</li> <li>In ASTIA collection</li> <li>Aval fr OTS: \$0.75</li> </ol> <p>UNCLASSIFIED</p>	<p>UNCLASSIFIED</p> <ol style="list-style-type: none"> <li>D. E. Hinds J. Cleveland</li> <li>In ASTIA collection</li> <li>Aval fr OTS: \$0.75</li> </ol> <p>UNCLASSIFIED</p>