

UNCLASSIFIED

AD 400 487

*Reproduced
by the*

**ARMED SERVICES TECHNICAL INFORMATION AGENCY
ARLINGTON HALL STATION
ARLINGTON 12, VIRGINIA**



UNCLASSIFIED

NOTICE: When government or other drawings, specifications or other data are used for any purpose other than in connection with a definitely related government procurement operation, the U. S. Government thereby incurs no responsibility, nor any obligation whatsoever; and the fact that the Government may have formulated, furnished, or in any way supplied the said drawings, specifications, or other data is not to be regarded by implication or otherwise as in any manner licensing the holder or any other person or corporation, or conveying any rights or permission to manufacture, use or sell any patented invention that may in any way be related thereto.

63-3-1

ASD-TDR-63-157

Investigation of Diplexing Transducers for Voice Communications

TECHNICAL DOCUMENTARY REPORT NO. ASD-TDR-63-157

February 1963

Electromagnetic Warfare and Communication Laboratory
Aeronautical Systems Division
Air Force Systems Command
Wright-Patterson Air Force Base, Ohio

Project 4335, Task 433506

(Prepared under Contract AF33(657)-7751

by Alan Dale Bredon under the direction
of George H. Sullivan,

Spacelabs, Inc., Van Nuys, California)

CATALOGED BY ASTIA

400487

AL NO. _____

3000
RECEIVED
JAN 21 1963

NOTICES

When Government drawings, specifications, or other data are used for any purpose other than in connection with a definitely related Government procurement operation, the United States Government thereby incurs no responsibility nor any obligation whatsoever; and the fact that the Government may have formulated, furnished, or in any way supplied the said drawings, specifications, or other data, is not to be regarded by implication or otherwise as in any manner licensing the holder or any other person or corporation, or conveying any rights or permission to manufacture, use, or sell any patented invention that may in any way be related thereto.

Qualified requesters may obtain copies of this report from the Armed Services Technical Information Agency, (ASTIA), Arlington Hall Station, Arlington 12, Virginia.

Copies of this report should not be returned to the Aeronautical Systems Division unless return is required by security considerations, contractual obligations, or notice on a specific document.

ASD-TDR-63-157

Investigation of Diplexing Transducers for Voice Communications

TECHNICAL DOCUMENTARY REPORT NO. ASD-TDR-63-157

February 1963

Electromagnetic Warfare and Communication Laboratory
Aeronautical Systems Division
Air Force Systems Command
Wright-Patterson Air Force Base, Ohio

Project 4338, Task 433806

(Prepared under Contract AF33(657)-7751

by Alan Dale Bredon under the direction
of George H. Sullivan,

Spacelabs, Inc., Van Nuys, California)

FOREWORD

This investigation was initiated by the Electromagnetic Warfare and Communications Laboratory under Contract AF33(657)-7751. The contract was in support of Project 4335 "Communications," Task 433506 "Personnel Communications." Mr. R. R. Schuster of the Telemetry Section of the Communications Branch served as contract monitor. Work on this study was conducted between 1 January 1962 and 28 February 1963.

Research, experimentation, and testing were performed at Spacelabs, Inc., Van Nuys, California, by Mr. A. D. Bredon, principal investigator, under the direction of Dr. G. H. Sullivan, Medical Director. Considerable assistance was provided by Dr. G. Weltman. The authors acknowledge the advice, contributions, and constructive criticisms of a large number of people. Those who contributed time and interest to a far more than routine extent were Drs. Fred Shillito and Henry M. Moser, Ohio State University, and Mr. Donald F. Dimon, Rolling Hills, California.

Spacelabs, Inc. designation for this report is SR62-1048.

This is the final report on Contract AF33(657)-7751.

ABSTRACT

The physiological problems relating to the wearing of communications microphones and headsets by personnel in aerospace vehicles are defined in this report.

Methods of providing full duplex voice communication with a single dual-purpose transducer are discussed. Air conduction, bone conduction, electrophonic phenomena, and direct radio frequency stimulation for the purpose of communication are considered in this study.

An ear canal insert diplexer system (dual-purpose transducer) is found through research and direct experiment to yield good intelligibility without interfering with other body functions. A superaudible chopper diplexing method is also selected as a promising technique for utilization of a dual-purpose transducer.

The use of the proposed systems in aerospace vehicles for extended periods is found to be entirely feasible.

PUBLICATION REVIEW

This report presents the findings of an Air Force sponsored applied research program. Publication of this report is approved to enable dissemination of this information. No specific application is indicated.

FOR THE COMMANDER



RONALD STIMMEL
Technical Director
Electromagnetic Warfare and Communications
Laboratory

TABLE OF CONTENTS

SECTION		PAGE
1	INTRODUCTION	1
2	DIPLEXING SYSTEMS	3
	General Discussion	3
	The Diplexer System	4
	Receiver Controlled Diplexer	4
	Chopper Diplexer	5
	Sub-audible and Audible	5
	Super-audible	7
	Resistive Bridge Diplexer	7
	Hybrid Transformer Diplexer	9
	Single	9
	Double	9
	Two Ear System	10
3	EAR INSERT MICROPHONE	11
4	ELECTROPHONIC HEARING	14
5	DIRECT RADIO FREQUENCY STIMULATION	16
6	NON-AUDITORY METHODS OF COMMUNICATION ...	17
7	METHODS OF IMPROVING INTELLIGIBILITY	18
	Binaural Hearing	18
	Binaural Hearing with 90° Phase Shift between Ears ..	18
	Fully Binaural (stereophonic)	18
	Spectrum Shaping	18
8	CONCLUSIONS	20
APPENDIX I	DIPLEXER ISOLATION TESTS	21
APPENDIX II	EAR INSERT MICROPHONE INTELLIGIBILITY TEST	27
APPENDIX III	ELECTROPHONIC HEARING TESTS	39

LIST OF ILLUSTRATIONS

FIGURE		PAGE
1	Receiver Controlled Diplexer - Block Diagram	5
2	Sub-audible Chopper Diplexer	6
3	Resistive Bridge Diplexer Block Diagram	8
4	Resistive Bridge Diplexer	8
5	Hybrid Transformer Diplexer - Single Coil	9
6	Hybrid Transformer Diplexer - Two Coil	9
7	Ear Insert Microphone	11
8	Crystal Controlled Oscillator	13
9	Direct RF Stimulation	16
10	Transmitting Ear Microphone	21
11	Hybrid Diplexer Test Setup - Single Coil Hybrid	22
12	Receiver to Transmitter Isolation - Single Coil Hybrid	22
13	Hybrid Diplexer Test Setup - Two Coil	23
14	Receiver to Transmitter Isolation - Two Coil Hybrid	23
15	Resistive Bridge Diplexer	24
16	Resistive Bridge Diplexer - Receiver to Transmitter Isolation	24
17	Resistive Bridge Diplexer - Receiver to Transmitter Loss	25
18	Resistive Bridge Diplexer - Transducer to Transmitter Loss	25
19	Resistive Bridge Diplexer - Crystal Transducer	26
20	Resistive Bridge Diplexer - Crystal - Receiver to Transmitter Isolation	26
21	Resistive Bridge Diplexer-Crystal-Losses	26
22	Ear Insert Microphone	28
23	Ear Insert In Place	28
24	Response of Knowles BE 1530 as Microphone	29
25	Response of Knowles BE 1530 as Receiver	29
26	Sound Power Spectrum of High-Noise Environment Plotted by Octave Band	32
27	Experimental Apparatus	33
28	Differences in the Performance of Receivers as a Function of Listening Environment and of Speaker	35

FIGURE		PAGE
29	Differences in the Performance of Microphone-Receiver Combinations as a Function of Speaker	36
30	The Effect of Speaker Noise Environment on Microphone Performance	36
31	The Effect of Listener Noise Environment on Microphone Performance	37
32	Insert Microphone Performance as a Function of Initial Consonant	38
33	Lip Microphone Performance as a Function of Initial Consonant	38
34	Electrophonic Hearing Test Setup	39

SECTION 1

INTRODUCTION

This investigation by Spacelabs, Inc., has been concerned with voice communications by personnel in aerospace vehicles; in particular, the transduction of speech.

Current experience with presently available sound transducers (microphones and speakers or headsets) has shown many undesirable effects upon aerospace vehicle occupants. When devices such as earphones of the headband type which either bind or clamp on the head are used, they are initially uncomfortable, and become nearly intolerable to the average subject after several hours. Lip microphones are bothersome over long periods because of the continual necessary contact with the lips. Such microphones also interfere with eating. Disorientation and isolation fatigue are additional important problems related to long duration aerospace missions. The effects of these discomforts on personnel confined to pressure suits over prolonged periods are especially serious and detrimental to efficient conduct of mission tasks and duties.

With these problems as known, certain basic parameters are quickly established for primary guidelines, or goals. First, using the same transducer for both transmission and reception could improve comfort through equipment reduction, and would, as a side profit, reduce the number of transducers by a factor of two. Second, reduce the size of this dual-purpose transducer, and place on the aerospace user in an area which will not disturb his normal functions and provide minimum or no discomfort or injury. Next, develop such a dual-purpose transducer with an adequate frequency response for proper communication and minimum fatigue. The problems of disorientation and isolation fatigue have been shown to be reduced if nearly continuous voice or music alternated with pink noise is provided to the personnel in the aerospace environment. However, it is very important that the least amount of distortion possible be introduced into the system. The use of a binaural system can help bring out listener presence more effectively, and improves the signal-to-noise ratio. The redundancy of the binaural type system also increases communications reliability. These and other factors are covered in more detail in other sections of this report.

The objective of this program has thus been to establish the criteria for development of an efficient, dual-purpose transducer which can be worn with an absolute minimum of discomfort during long missions in the confines of pressure clothing and aerospace environments. This objective study also includes the definition of the circuitry that would be necessary to obtain the desired effect, now referred to as the "diplexer effect".

In conducting this program, Spacelabs, Inc., has attempted to investigate all methods offering any promise of success, so as to not overlook any valuable work done in the past. An extensive and comprehensive search through literature on the general subjects of speech, hearing, intelligibility, acoustics, noise, and non-auditory communication was made, and all findings carefully analyzed for their possible value. From this collection of data, several methods of obtaining the "diplexer effect" have been experimentally investigated. These investigations and experiments are described in detail in this report.

SECTION 2

DIPLEXING SYSTEMS

General Discussion

A diplexing system, as referred to in this report, means a system using a single, dual-purpose transducer to function both as a microphone and a speaker (or earphone). The problem involved in designing an efficient diplexing system is primarily that of providing adequate receiver-to-transmitter isolation.

NOTE: The terms "receiver" and "transmitter" used herein, refer to the RF link and are not to be confused with "microphone" and "speaker".

An optimum diplexer may be defined as a device in which the amplitude (at the transmitter input) of the receiver to transmitter crosstalk signal, at comfortable listening volume, is equal to (or less than) the amplitude of the speech signal, at normal speaking volume. The actual isolation required between the receiver output and transmitter input is dependent on the characteristics of the selected microphone, its placement, and circuit losses (receiver to transducer loss, and transducer to transmitter loss). Isolation must be 32 db or greater over the entire speech spectrum if a dynamic microphone is used.

Many types of sound transducers will function reasonably efficiently both as microphones and as speakers. Some are more suitable than others for this purpose. Dynamic piezo-electric crystal, condenser, and ribbon types all have a reversible characteristic. Crystal and condenser type microphones are less desirable for the purpose of this study because they require high impedance preamplifiers. The ribbon type microphone is generally less rugged than the others, in addition to being a high impedance device. As will be explained below, the condenser type microphone is highly desirable in a certain type of diplexer (superaudible chopper). For most purposes, however, the dynamic type sound transducer is the most useful.

When picking the location for a dual purpose transducer, several points must be considered. Transduction path losses will influence the isolation required in the diplexing circuitry. Signal distortions introduced by frequency-dependent path losses and multipath interference problems will seriously affect the intelligibility produced by the system. A device to be worn for long periods must not press on the skin in excess of approximately 0.3 psi to prevent restriction of the blood supply to underlying tissues.

Other investigators have suggested several locations for dual purpose sound transducers. These include tooth, forehead, behind the head, ear canal, and other locations (ref. 10, 224, 225, 226, 227, 133-138, 233). Sound Transducers at the tooth and forehead locations operate as bone conduction devices, and the use of bone conduction for reception was discarded by earlier investigators (ref. 227, P8, and A 4-4) due to the high sound pressure levels required (a minimum of 60 db higher than air conducted sound) and the possibility of cavitation occurring in the blood vessels.

The tooth microphone has merit, but as a receiver, it would function as a bone conduction mechanism. Little is known about the physiological effects of vibrating a tooth with sufficient amplitude to produce the necessary loudness. It would be possible, however, to use this method for both transmission and reception.

A dynamic speaker-microphone behind the head could be used as a dual purpose sound transducer. As a microphone it has a distinct disadvantage, however, because of the distance from the mouth. This would cause distortion, especially when used in a helmet, producing a "head in a can" effect. Intelligibility would suffer markedly. In addition it would be of no use in high noise fields. The ear canal location is ideally suited for a speaker. Such a configuration provides excellent coupling between the sound transducer and the ear mechanism. Moreover, the ear canal has been shown to be a reasonably good location for a microphone (ref. 10, 133-138), particularly when proper compensation for the frequency distortion caused by the sound path through the head is utilized, (ref. 10, 190, 224-227). Some further improvement may be obtained by over compensating for this effect to obtain an overall upslope in frequency response.

The Diplexer System

The operation of a device as a dual purpose sound transducer may be accomplished with varying degrees of success in several ways. The mechanism for implementing this action is called a "diplexer" in this report. Five general classifications of diplexers have been investigated. These systems, and the experiments and tests performed on them, are described in the following paragraphs.

It should be pointed out that the microphone used for most of the tests described in this report appears to be a poor choice for use in a diplexing system because of its very erratic impedance characteristics. However, this impedance characteristic is fairly typical of dynamic type microphones and is perhaps offset by the many other characteristics which are quite desirable. It has been obvious throughout these experiments that the inability to achieve good isolation has resulted from the complex impedance curve. If the impedance has a steady rise or steady fall, it would be no problem to build a diplexer that would work with good receiver-to-transmitter isolation. However, since most of the dynamic type microphones show a rising then falling then rising again characteristic (or worse), it is almost impossible to balance the network properly.

An inexpensive crystal microphone was tested in a resistive bridge diplexer. This unit exhibits a more linear impedance curve. Much better receiver-to-transmitter isolation was attained, thus indicating the advantage of the linear curve.

Receiver Controlled Diplexer

The receiver controlled diplexer (see figure 1) is a device using a transmit-receive switch, and, therefore, cannot be used for simultaneous two way communication. The switch is controlled by the received signal. A squelch signal, AVC signal, or rectified audio signal can be utilized to operate the switch. The switch can be a mechanical or

solid state device. The switch would be in the transmit mode at all times except when a signal was actually being received.

The so-called "voice-operated-relay" type of transmit-receive switch cannot be employed in the subject application because of the use of a single dual purpose sound transducer. The received signal would activate the T-R switch, and cut itself off. Furthermore, if sufficient circuitry is employed to allow use of the voice-operated-relay, more than enough isolation (between receiver output and transmitter input) will have been achieved to obviate the necessity of using the switch in the first place.

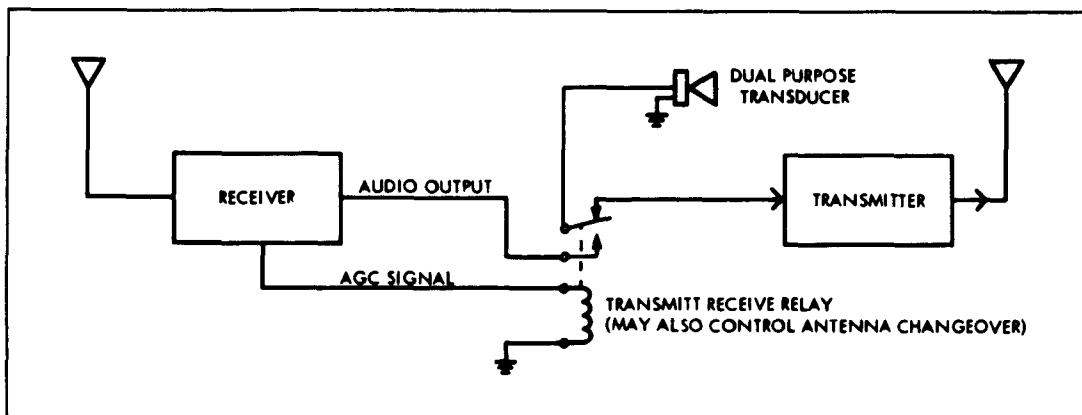

Figure 1. Receiver Controlled Diplexer - Block Diagram.

A distinct disadvantage of the receiver controlled diplexer is the fact that the user does not have positive control over its operation. A manual override switch could be provided, but the lack of positive non manual control would still compromise usefulness of the diplexer. It has been found that providing music, alternating with "pink" noise, helps to combat isolation fatigue, therefore the receiver would be on a good deal of the time. It is felt that this system would be a handicap in situations requiring fast action. There is also the possibility that interference could lock the device in the receive mode and prevent transmission (unless an override switch was used). This would be intolerable in an emergency situation.

No experimental work was conducted on this system since the techniques are well known and the serious disadvantages preclude the use of this system in aerospace vehicles.

Chopper Diplexer

If a transmit-receive switch were thrown back and forth at a high rate, incoming speech would be intelligible, and the transmitting capability would be continually present. This method is termed chopper diplexing. It may be divided into two sub-classifications.

Sub-audible and audible:- It has been found that speech may be interrupted at low audible rates while retaining reasonably good intelligibility (ref. 43, 126). For instance,

at 20 cps at 50% duty cycle, the word articulation score is 84 percent. At very low frequencies the intelligibility is approximately equal to the percentage "on" time. As the chopper drive frequency is increased, a minimum of approximately 40% intelligibility at one cycle per second is reached. The curve then rises to 84% at 20 cps, and 90% at 100 cps; then falls somewhat (to about 80%) through the speech spectrum; finally rising to essentially 100% at 10 kc.

Chopper drive frequencies above approximately 20 cps and below the maximum voice frequencies (approximately 10 kc) add annoying sum and difference frequencies to the speech sounds. Chopper frequencies below approximately 20 cps give annoying "interrupted" sensations. It has been found, both in the literature and by Spacelabs, Inc., experiments relating to this report, that audible or sub-audible rates give intelligible but annoying and fatiguing results.

A breadboard test fixture was constructed (see figure 2). This device has a maximum chopping frequency of about 30 cps. While the device did yield intelligible speech on both reception and transmission, the quality was poor and very annoying to the test subjects. Various degrees of filtering were tried from points A, B, and C to ground. The filtering tended to make the sound somewhat less disturbing, but the effect was slight. Excessive filtering lowered the intelligibility. Although no formal intelligibility test was run, it appeared that the figures in the existing reference literature were probably correct. It was obvious to the experimenter that while this system might be extremely practical in an inexpensive low speech quality emergency system, it would not be usable in a high quality continuously operating device.

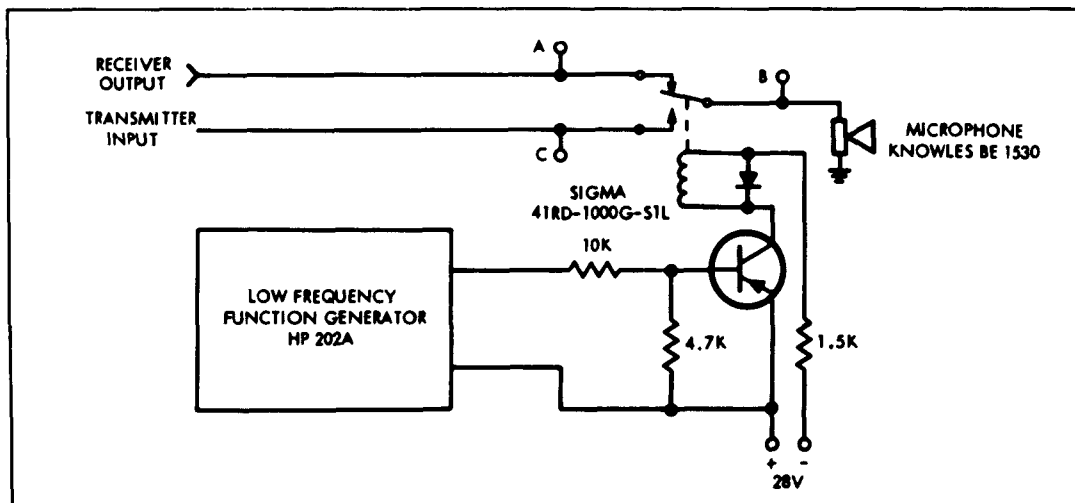

Figure 2. Sub-audible Chopper Diplexer.

Miller and Licklider (ref. 126) report that filling the off spaces with noise improves the quality, but not the intelligibility. More recently, however, Stewart (ref. 191) has shown that "reiterated" speech considerably improves the quality. Reiterated speech

is described as "interrupted speech with the blank periods filled with the same interrupted speech delayed by the "on periods" (ref. 180). Stewart carries the process a step further to eliminate switching transients. His system utilizes four delays, so that 4 signals are mixed in the adder (e.g. delay 1 = 0, delay 2 = $T/2$, delay 3 = T , delay 4 = $3T/2$). He compares the effect of the multiple delay to that of "speech in a reverberant environment."

It should be noted here that this system has excellent receiver-to-transmitter isolation, the isolation perfection being governed only by circuit stray capacities and impedance levels. No further experimental effort on the sub-audible chopper was deemed warranted for the purpose of this study.

Super-Audible - By increasing the chopper drive frequency above the audible range (higher than about 20 kc) the sum and difference frequencies are eliminated. After sufficient low pass filtering, essentially undisturbed speech remains (standard sampling theory). Unfortunately, this method is not practical with most sound transducers due to the "flywheel" effect of the moving parts. However, if a transducer is chosen with an extremely high resonant frequency, say 5 times the drive frequency, or 100 kc, the diaphragm or other moving parts can return to zero during switchover time. This type of diplexer will most likely work with a high frequency capacitor microphone or any similar type with resonant frequency above 100 kc.

It is not known at this time if the action of Rindner's device (ref. 159-163, 169) is reversible; however, the action of the capacitor microphone is reversible and it is often used as a speaker for calibration purposes. A distinct disadvantage of the capacitor microphone is the requirement for a high polarization voltage (typically 200 volts). This method of diplexing should definitely be investigated further. Spacelabs, Inc., data indicate that this method has been almost completely neglected in previous investigations. No further experimental evaluation was possible on the super-audible chopper at this time.

Resistive Bridge Diplexer

This method uses bridge nulling techniques to attain the necessary receiver-to-transmitter isolation (see figure 3). The sound transducer is used as one leg of the bridge and a balancing network as an adjacent leg. The receiver and transmitter are then connected to the "input" and "output" of the bridge. By selecting components such that the impedance of the balancing network equals the microphone impedance, excellent isolation is possible. Unfortunately, good matching over the entire speech spectrum is not possible with most commonly available sound transducers.

This type of device, using a dynamic microphone, has been breadboarded (see figure 4) with some degree of success. It is possible, with a very simple resistive bridge, to obtain a receiver to transmitter isolation of approximately 20 db. Refer to Appendix I for test data. However, it has been found that about 32 to 40 db is necessary for proper operation of the full duplex type system. The addition of a hard clipper at the input to the transmitter would allow this system to be used efficiently. The hard clipper would prevent overmodulation of the transmitter during the receiving period. It also would have the

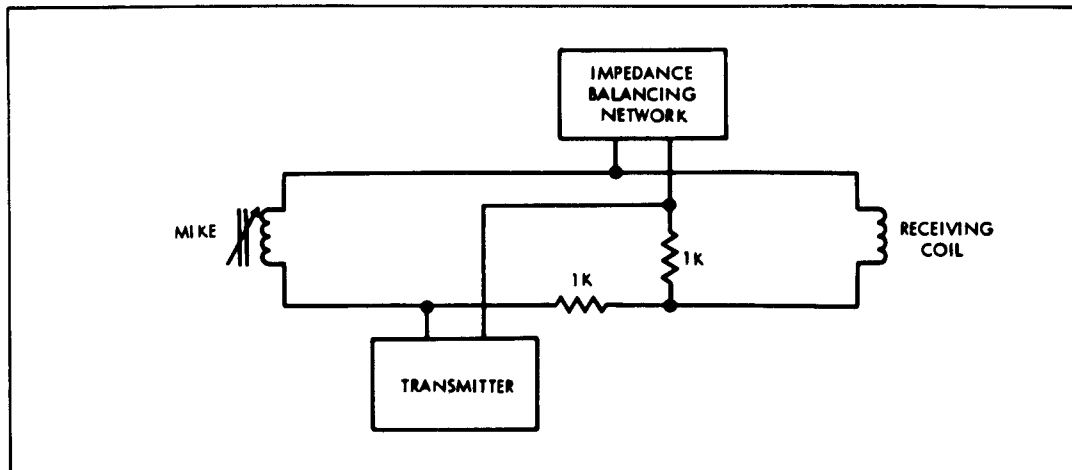

Figure 3. Resistive Bridge Diplexer Block Diagram.

function of preventing overmodulation from the microphone itself. This would be a desirable feature. It has been found, with the proper upsloping of the speech spectrum, that hard clipping does not adversely effect intelligibility to a great extent (ref. 43, 114). In some cases, clipping actually improves the intelligibility of speech.

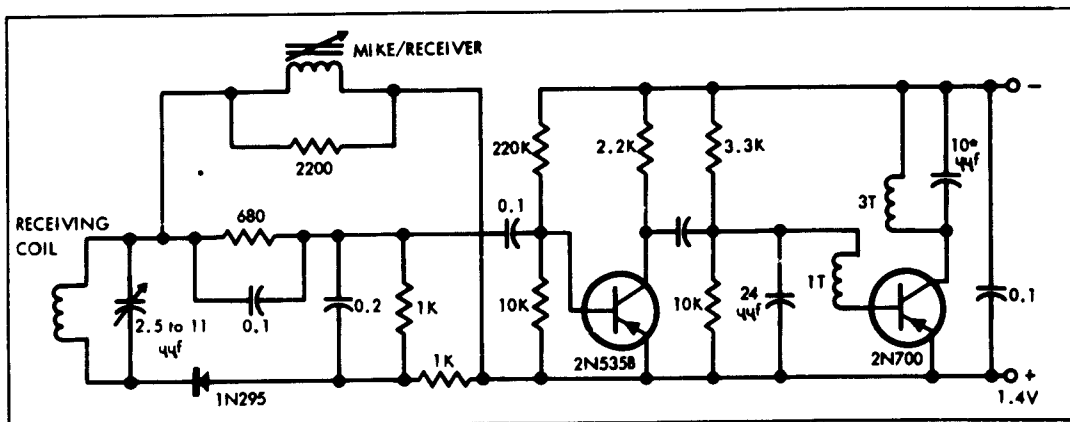

Figure 4. Resistive Bridge Diplexer.

Tests of the resistive bridge diplexer have also been performed using a crystal microphone. These tests yielded improved receiver-to-transmitter isolation. Refer to Appendix I for details. The intelligibility tests on the ear microphone (refer to Appendix II), even though performed on separate ear microphones and ear canal receivers, accurately represent the capabilities of the ear insert resistive bridge diplexer (as breadboarded). This intelligibility can be improved as indicated in section 7 by proper upsloping.

Hybrid Transformer Diplexer

The comments for the resistive bridge, preceding, apply except the bridge is formed by one or more multi-coil transformers.

Hybrid Transformer Diplexer - Single: - See figure 5. This device has been found to yield between 20 and 30 db attenuation, transmitter to receiver. This is not enough better than the resistive bridge to warrant the larger space taken up by the hybrid transformer. If space is not at a premium, however, this device will function fairly well. Again, the hard clipper at the transmitter input would improve the operation of this device. The circuit shown in figure 5 is capable of better than 50 db isolation when Z_o and microphone impedance are accurately matched. For example, by substituting a 2200-ohm resistor for the microphone the isolation exceeds 50 db at all frequencies from 60 cps to 10K cps. A microphone in shunt with 2200 ohms at both " Z_o " and "Microphone" yields a minimum isolation of 27 db (at 4.6kcps) over the voice spectrum.

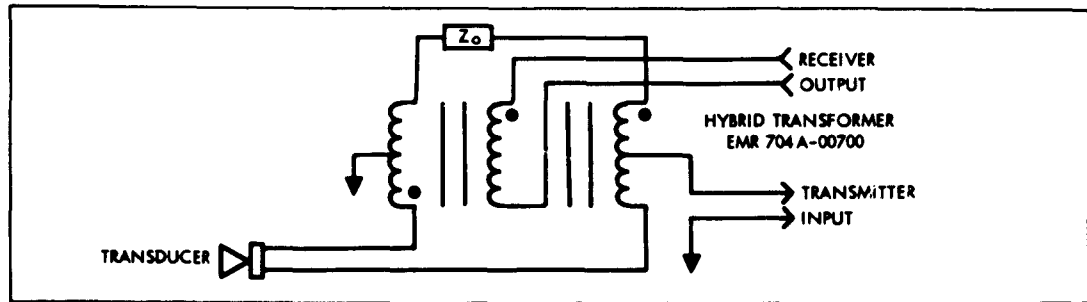

Figure 5. Hybrid Transformer Diplexer - Single Coil.

Hybrid Transformer Diplexer - Double: - See figure 6. This type of diplexer has been found to have approximately the same attenuation as the single transformer type. No clear advantage was noted. In addition, it is larger, requiring two transformers.

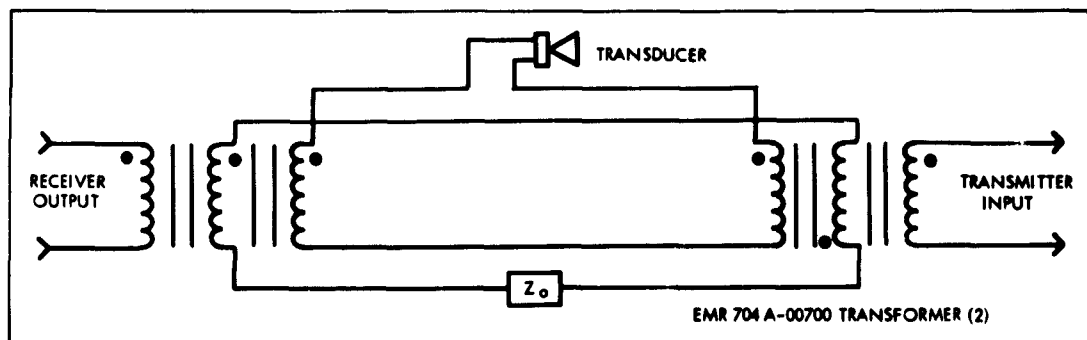

Figure 6. Hybrid Transformer Diplexer - Two Coil.

Two Ear System

Although it does not exactly fulfill the requirements of a diplexer, the two ear system works well. In this case, the microphone is in one ear, while the receiver is contained in the other ear. Excellent receiver to transmitter isolation (in excess of 50 db) (ref. 188) is obtained in this manner. However, it would be impossible to provide binaural hearing or system redundancy by this method.

This system does not meet the requirements for a dual purpose transducer. However, it is, no doubt, the simplest and most economical of the diplexing systems discussed here, and it is mentioned for that reason.

SECTION 3

EAR INSERT MICROPHONE

The ear insert microphone (figure 7), one of the most promising of the duplexing transducers, has been investigated quite thoroughly.

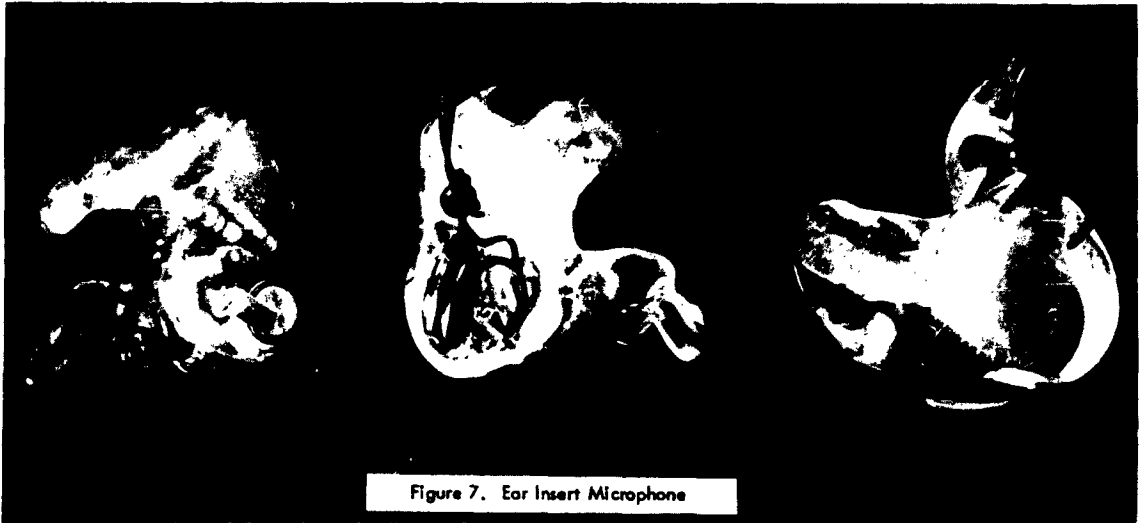

Tests were run using two speakers and several listeners in order to determine the intelligibility of this device (refer to Appendix II for complete test method and detailed results). Compared to the noise cancelling lip microphone, this method is somewhat inferior. However, it is placed in such a position on the body as to eliminate interference with eating and other necessary body functions. It is also in a position where it is relatively free from the effects of noise up to approximately 120 db. Although some degradation does take place, the intelligibility for sentences is quite high even at 110 db (approximately 96 percent). This, however, is dependent on the use of ear defenders. The ear microphone is excellent in such a case since the ear defenders do not interfere with the operation of the ear microphone. In fact, they improve its operation at all noise levels, and, likewise, the ear microphone does not interfere with the ear defenders.

Providing a frequency response upslope of approximately 12 db per octave over the full speech spectrum increases the intelligibility of the ear microphone to a marked extent. This is due in part to the slope of the attenuation characteristic from mouth to ear of approximately 9 db per octave (ref. 10) and in part to the increase in intelligibility produced by upsloping (ref. 190, 225). During Spacelabs, Inc., tests of the ear microphone against the noise cancelling lip microphone, it was not economically possible to fully provide this upsloping above 2 kc.

NOTE: Even though the frequency response of the microphone in use on these tests is poor when used as a microphone, the response when used as a speaker is reasonably flat from 200 cycles to 6 kc, and provides very excellent listening fidelity.

It has been found that the ear insert microphone is not uncomfortable to wear, although there is some conditioning period for most subjects. The conditioning involved with such a microphone or ear insert is very closely akin to that of a normal person and his new dentures. However, the conditioning for the ear microphone is probably easier than for false teeth because (1) the subject is not biting or chewing anything; and, (2) the problem of getting little bits of food under the insert is not present. This device has been worn by several Spacelabs, Inc., personnel for periods as long as eight hours and not found to be uncomfortable over these periods. A long term test of 36 hours (continuous) with two subjects was conducted. This time included two sleeping periods. The device caused essentially no discomfort and the test could have continued longer. No conditioning period was used before the test for either subject. Some details follow:

- Subject 1. A physician's examination at the end of the test disclosed two minor irritation areas. These were probably due to high spots on the ear mold and could be prevented by a better fit.
- Subject 2. A physician's examination at the end of the test disclosed no adverse effects.

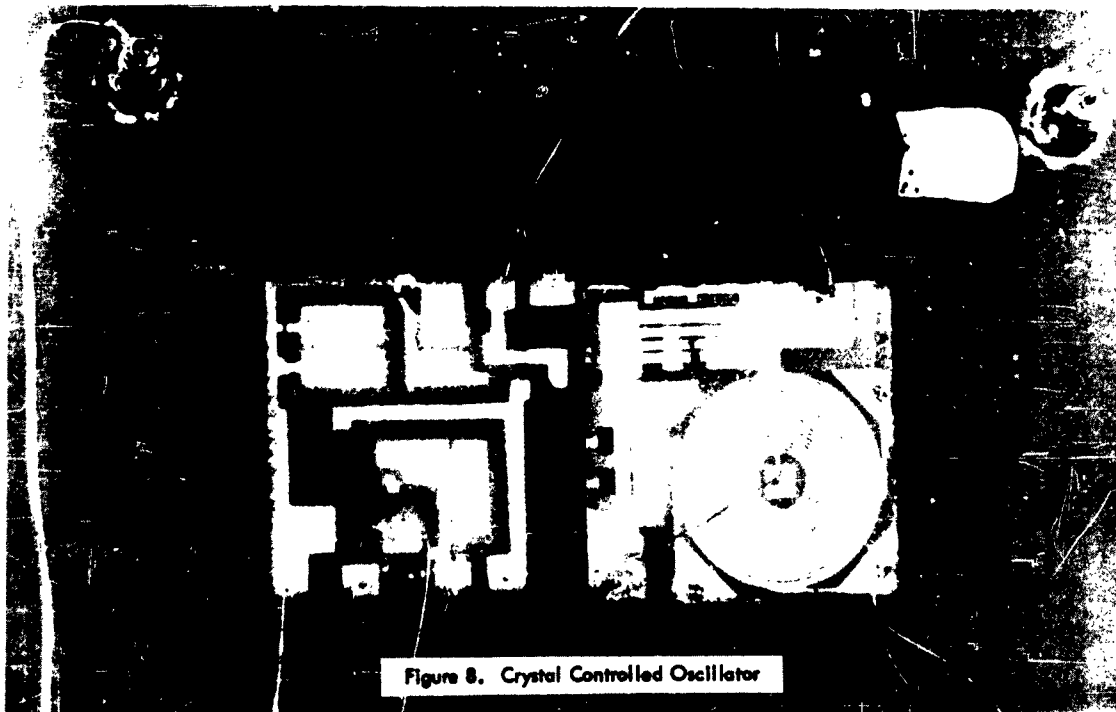

Figure 8. Crystal Controlled Oscillator

PHOTO COURTESY OF MOTOROLA, INC.
SOLID STATE SYSTEMS DIVISION

Recent announcements by the Raytheon Company of a new, extremely small microphone are of interest to this study. Spacelabs, Inc., is in the process of obtaining further information on this device, but as yet has had no reply. This microphone would make it possible to reduce slightly the size of the ear insert diplexer and, according to the sketchy data on hand at this time, would improve the characteristics of the device by providing better frequency response (ref. 159-163).

During the course of the investigation on this project, a feasibility model of a transmitting ear microphone has been constructed using standard techniques (figure 7). This device fits entirely within the outer ear and yet provides very excellent speech pickup from this location. It is possible, by using deposited circuitry or similar microcircuit techniques, to place an entire diplexing system within the same space. Figure 8 is a photo of the deposited circuitry for a crystal controlled transmitter.

SECTION 4

ELECTROPHONIC HEARING

Electrographic hearing is defined as the hearing of sound produced within the ear by direct action of alternating electrical current. There is some doubt as to the actual mechanism involved in electrographic hearing, and several theories have been brought forth. One theory is that in the normal ear the electrographic hearing transduction occurs within the outer ear as a surface effect. It has also been suggested that the sound is produced by a capacitor action using the tympanum as one plate and the opposite wall of the middle ear as the other plate (ref. 99).

This theory, however, has been discredited by recent work by Gordon Flottorp (ref. 70). This phenomenon, or the hearing of sound without an actual external transducer, at first appears excellent for use in the aerospace environment. This would be especially true if the reverse action or cochlear microphonic signal could be utilized in place of a microphone. Experimental work, however, indicates that the loudness produced is not very high (ref. 187, 189). This, of course, would make electrographic hearing completely unusable in the presence of any external noise. In addition, the cochlear microphonic is difficult to pick up and is very low in amplitude (ref. 76, 86, 112, 113, 172, 173, 174).

The first mention of sounds produced by direct electrical stimulation was made in 1800 by A. Volta (ref. 201). He used direct current from a battery of 30 or 40 cells. Upon placing a probe in each ear and closing the circuit, he first received "a shock in head", then "a sound, or better a noise, in the ears." Apparently, little serious work was done with this phenomenon until about 1935, when B. Fromm published his work on "Studies in the Mechanism of the Weaver and Bray Effect" (ref. 76; also 81). The Weaver and Bray effect is what we now refer to as the cochlear microphonic. Fromm used the reverse of this effect by placing an electrode in the ear and stimulating with an AC current. He found that ten out of eleven subjects had definite reactions from this electrical stimulation. In 1937, S. S. Stevens published a paper titled "On Hearing by Electrical Stimulation" (ref. 187). Stevens made use of electrodes placed in saline in the external meatus, with the ground on the arm. He found that the electrographic threshold was about 20 db above 1 microwatt, which is only 20 db below the shock level. Thus the loudness attainable by electrographic hearing is limited by shock or pain sensation. He found that the tones were extremely distorted. Popular tunes could be identified but quality was quite poor. Speech was recognized as speech, but few words were understood. In 1937, K. J. W. Craik, et.al. (ref. 25), discovered that the use of bias DC current reduced the distortion of the wave forms. Unfortunately, they misinterpreted the cause of the distortion as being that the positive and negative portion of the waveform act identically at low frequencies, rather than the fact that the mechanism is actually a square law device. In 1939, Stevens et.al (ref. 189), also suggested applying a DC polarizing current along with the alternating stimulus, which allowed the fundamental to be heard where otherwise only the second harmonic was heard. In 1940, R. C. Jones, et.al (ref. 99), ran tests involving electrographic hearing on 20 subjects. This investigation was primarily to indicate the difference in the sounds perceived by normal and operated ears (without

tympanic membrane). Of the 20 operated ears, 9 heard a pure tone, 5 heard buzzing only, 2 heard buzzing at lower frequency and tones at the higher frequencies, and 4 heard nothing. Of these last 4, 2 had large amounts of scar tissue filling the middle ear, 1 had no cochlea and 1 had labyrinthitis (complete loss of hearing). This work indicated that the pure tone response of operated ears is linear.

Very little has been found in the literature for the period between 1941 and 1952. In 1952, Gordon Flottorp (ref. 70) did a considerable amount of work with electrophonic hearing. In this investigation he used a great number of different types and sizes of electrodes and was more interested in the effects peculiar to a particular electrode type than in the electrophonic effect per se. His results attributed the sounds to vibrations set up outside the cochlea, and he postulates four different transducing mechanisms. He did not feel that the tympanic membrane was involved in converting electrical to mechanical energy. In 1961, A. H. Frey published "Auditory System Response to Modulated Radio Frequency Energy" (ref. 73, 74, 75). (See Direct Radio Frequency Stimulation.) It is not known at this time whether this mechanism is the same as that involved in electrophonic hearing or an entirely different mechanism. There is some reason to believe it may be direct cortical or nerve fiber stimulation.

Some work has been done recently on direct electrical nerve stimulation by implanted devices (ref. 40, 41, 42). These investigations are aimed at providing some hearing to totally deaf people. Since these techniques involve surgical implantation, and as yet are unable to provide intelligible speech to the subject, they are not of great interest to this current study. A knowledge of the complexity of the auditory system processing mechanism casts doubt that these experiments will ever produce a vocabulary of more than a few words. Since the intensity of the tone produced by electrophonic hearing is quite low, never above 25 or 30 db sound level, and usually around 10 db, and considering that the threshold of discomfort is rather close to the electrophonic threshold, and for some frequencies is even lower than the hearing threshold, it is obvious that this means of communication is not practical (ref. 187, 189). Consider, for instance, that the normal office noise is at least 60 db (of course aircraft and aerospace vehicle noise is considerably in excess of 60 db). This would yield at best a -30 db signal to noise ratio. Experimental work was conducted at Spacelabs, Inc., to verify these findings (ref to Appendix III). It was found that the perceived sound was quite faint, and in the Spacelabs, Inc., facility (approximately 60 db noise level), the sound could barely be detected, even though ear defenders were used by the subject.

SECTION 5

DIRECT RADIO FREQUENCY STIMULATION

In 1961, A. H. Frey published "Auditory System Response to Modulated Radio Frequency Energy," (ref. 73, 74, 75). In this paper the author reported that the human auditory system can directly detect radio frequency energy. Several RF frequencies were used; however, no actual voice communication took place, as the transmitters were not modulated for this purpose. The transmitters used by Frey were pulse modulated (radar type) devices. The subjects reported that the perceived sound was more like that produced by the modulation pulses than by pure or complex tones or square waves. However, they stated that more high frequencies were needed even when listening to the modulation pulses by means of a speaker. The mechanism involved is in doubt, but there is reason to believe it may be direct cortical or nerve fiber stimulation.

Lately, several articles have appeared in non-technical magazines describing an invention of Pat Flanagan (ref. 130). This device is claimed to transmit sound directly to the brain by radio frequency waves. Attempts to get more information from Mr. Flanagan or to witness a demonstration have been completely unsuccessful. It appears that the claims for this invention are not true. The sound is evidently peripheral in nature, and could be considered a special form of electrophonic hearing. However, Specelabs, Inc., experiments indicate that it is possible to produce much more intense sound than by direct audio frequency stimulation, without the discomfort of shock or vestibular nerve stimulation. A subjective loudness equivalent to approximately 60 db SPL is attainable with relative simple equipment (see figure 9). It should be noted that marked tissue heating (diathermy effect) is produced near the electrodes at the power levels used. Over-heating could, of course, cause permanent tissue damage (ref. 176).

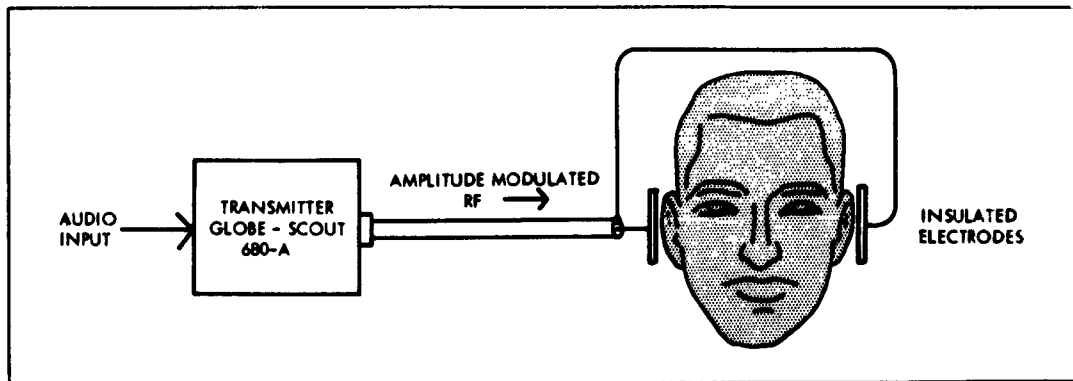

Figure 9. Direct RF Stimulation.

Informal experiments were conducted using the A-B technique (alternate presentation of RF stimulation and the audible output from a receiver) with pure tones, speech, and music. These experiments indicated that the perceived sound is relatively undistorted. Although no definite conclusions can be drawn from this work, it indicates the presence of a linear detector mechanism. This phenomenon definitely deserves further investigation.

SECTION 6

NON-AUDITORY METHODS OF COMMUNICATION

Many types of non-auditory communications are usable in the aerospace environment.

In 1958, W. R. Uttal (ref. 197) described experiments using pulses from 1/100 millisecond to 10 milliseconds (in areas such as the skin of the arm), which gave sensations described as slight localized taps. These tests of peripheral excitation, however, do not suggest that voice communications could be carried out by electrically stimulating organs other than the ear.

Geldard and others have done considerable work on vibratory stimulation (ref. 11, 78, 79, 80, 183). Experiments were conducted on word recognition by vibratory stimulus of the fingers, but these were not successful. They indicated that it was wrong to force a receptor system to adjust to the world's hardware. Geldard describes a practical method of coding (ref. 80) using three steps of intensity, three steps of duration, and five points of contact. This system has yielded a 90% accuracy at a rate of 38 words per minute.

Extra-Sensory Perception (Telepathy) was given consideration as a means of communication. All available data (ref. 152, 157) indicates that the accuracy only slightly exceeds chance and then only to so called "sensitives." No documentation indicating useful communication possibilities of ESP could be found.

SECTION 7

METHODS OF IMPROVING INTELLIGIBILITY

A number of factors affect the intelligibility of voice communications, especially in the presence of noise or other interference. This section discusses some of the factors which are pertinent to this contract.

Binaural Hearing

The acuity of two ears is nearly 2 db better than that for one ear (on the basis of signal to noise ratio) over most of the speech spectrum, increasing above 5K cps to about 5 db at 7K cps (ref. 72). This has been shown to be true for sound levels as high as 120 db. Therefore, it is apparent that binaural systems are to be preferred to single ear, monaural systems.

Binaural hearing with 90° phase shift between ears

In this system the sound is shifted a constant 90° in phase (ref. 104, 229, 230). This produces a difference in arrival time between the ears that is frequency dependent. The subjective effect of this is to produce an apparent spatial relationship between sounds of different frequencies. This improves the ability of the ear to discriminate sounds in the presence of interference, whether it be noise, other voices, hum, or continuous tones. This makes use of the so called "cocktail party effect," (ref. 229, 237), which is the ability of the auditory system to single out desired signals on a directional basis. The use of this system is said to produce a 3 db improvement in signal to noise ratio.

Fully Binaural (stereophonic)

The system has a serious disadvantage in that it requires a larger transmission bandwidth. However, if 100% redundancy is desired, the use of a stereophonic system will improve the overall intelligibility. The advantages of the 90° phase shift system are retained ("cocktail party effect" discrimination). In addition, if two completely separate channels are used, much of the noise and interference will not occur simultaneously on both of them. This aids the auditory system in discriminating between the desired and undesired signals.

Spectrum Shaping

It has been well established that various forms of spectrum shaping can effect intelligibility. Low pass or high pass filtering (bandwidth restrictions) fall in this category. In general any amount of either high pass or low pass filtering (or both) have an adverse effect on intelligibility. On the other hand upsloping the spectrum,

within limits, has a favorable effect on intelligibility in the presence of noise. For instance, Pickett and Pollack (ref. 147, 150) show that, at a noise level of 90 db and signal-to-noise ratio of minus 6 db, a percent words correct score of approximately 24% is obtained using flat equipment and noise spectra, and about 72% is obtained using speech upsloping of 6 db per octave and flat noise. The upsloping is actually an equipment frequency response tilt, producing increasing amplitude with increasing frequency. Stewart (ref. 190) indicates that an effective increase of 4 db in signal-to-noise ratio can be achieved by pre-emphasis of high frequency speech components (eight or nine db per octave). It has also been found that upsloped (differentiated) speech may be clipped with less loss of intelligibility than "flat speech". Furthermore, if the clipped speech is integrated (downsloped) at the receiver, it retains much of its original quality (ref. 114).

In general it may be stated that anything which destroys recognizability is a step backward. Any signal processing for the purpose of increasing intelligibility must take recognizability into account.

SECTION 8

CONCLUSIONS

The investigation and experimentation of this contract have indicated that it is feasible to utilize a single dual purpose sound transducer for voice communications in the aerospace environment. Two of the several systems investigated deserve further attention.

First, the Ear Canal Insert Diplexer: This device is placed in an ideal location for receiving purposes, and a reasonable good one for transmitting. In addition, it does not interfere with the other body functions such as eating. In the opinion of Spacelabs, Inc., the resistive bridge diplexer (with hard clipper) used as an ear insert offers very attractive possibilities as a dual purpose transducer for aerospace vehicles. The use of micro-circuit techniques such as deposited circuitry makes the fabrication of the ear canal insert diplexer entirely practical.

Second, the Super-Audible Chopper Diplexer: This system has been neglected in previous studies, but shows possibilities of providing an excellent diplexer. Unfortunately, little experimental work could be done on this device under this current contract. The super-audible chopper diplexer has the potential of providing the highest receiver-to-transmitter isolation of all methods investigated. It can also provide excellent reproduction fidelity.

In addition to the preceding, the ear canal insert microphone is practical for purposes other than diplexer system. It provides reasonably good quality speech. The unit is light in weight, and is located in a somewhat protected location. Its appearance is unobtrusive, and it could be made nearly invisible by using advanced microcircuit techniques. The operation of the ear canal insert microphone in the presence of noise is comparable to other microphone systems, and is greatly exceeded only by the differential noise-cancelling types.

It is concluded both from previous experimental work and from Spacelabs, Inc., work during this study, that the electrophonic hearing method is of no use in any environment other than an extremely quiet one. It would, therefore, be completely useless in any present day aircraft or aerospace vehicles.

The other systems and phenomena investigated have failed to yield results indicating usefulness in the aerospace environment. A possible exception to this is direct reception of radio frequency energy, which could prove useful in a quiet environment under certain limited circumstances. This phenomenon should also receive further investigation, especially to determine threshold levels and safe power density limits.

APPENDIX I

DIPLEXER ISOLATION TESTS

These tests on the Hybrid transformer and resistive bridge diplexer were performed on breadboard type equipment. In all cases, the receiver was simulated with a Hewlett-Packard Model 200CD oscillator. The transmitter utilized was the unit constructed for some of the ear microphone tests (figure 10). Voltage levels were measured with a Tektronix Model 502 Oscilloscope.

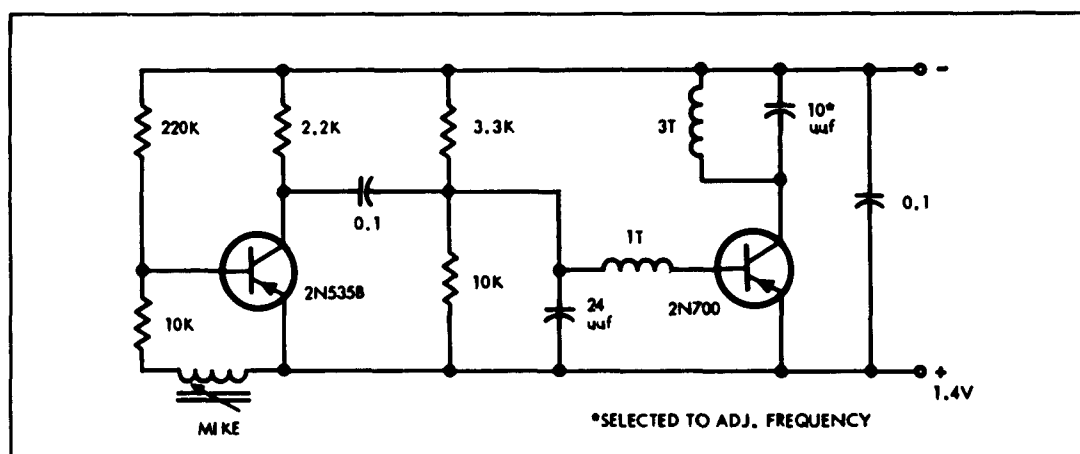

Figure 10. Transmitting Ear Microphone.

A. Single Coil Hybrid Transformer Diplexer

Isolation tests were performed on the circuit shown in figure 11. The receiver output to transmitter input isolation is shown in figure 12. Receiver to microphone loss is approximately 6 db, and microphone to transmitter loss is between 9 and 12 db, depending on frequency. The transformer used (EMR 704A-00700) is capable of providing a minimum of 50 db isolation (at 10 kc) when resistors are substituted for the microphones.

B. Two Coil Hybrid Transformer Diplexer

Isolation tests were run on the circuit shown in figure 13. Use of a second microphone at "balance" yielded results nearly identical with that of the one-coil device. Therefore no separate curves are given.

The circuit was balanced for optimum isolation (null at 1000 cps) by use of a 700 ohm resistor at balance. The results are shown in curve figure 14. This curve is also typical of the results attainable with the one-coil device when using passive components at "balance".

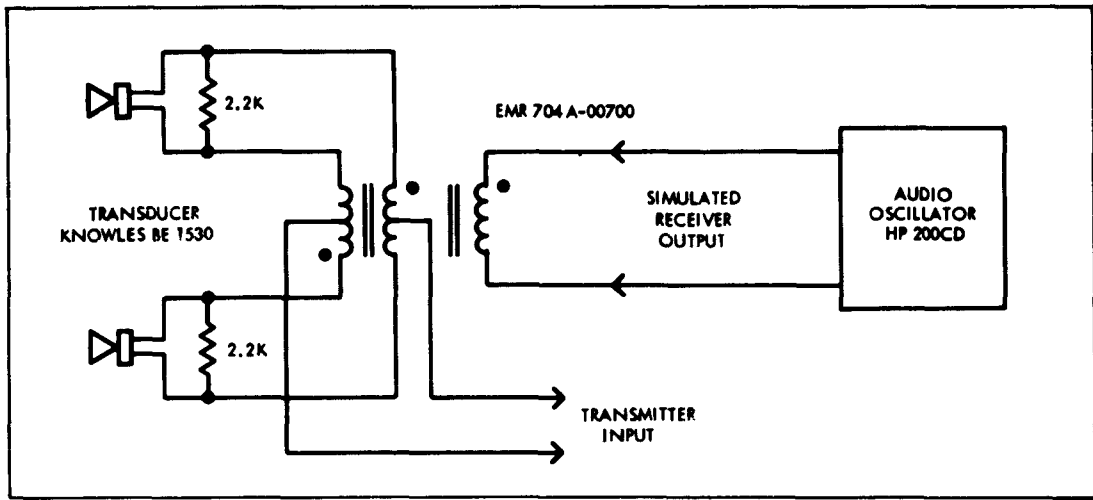

Figure 11. Hybrid Diplexer Test Setup - Single Coil Hybrid.

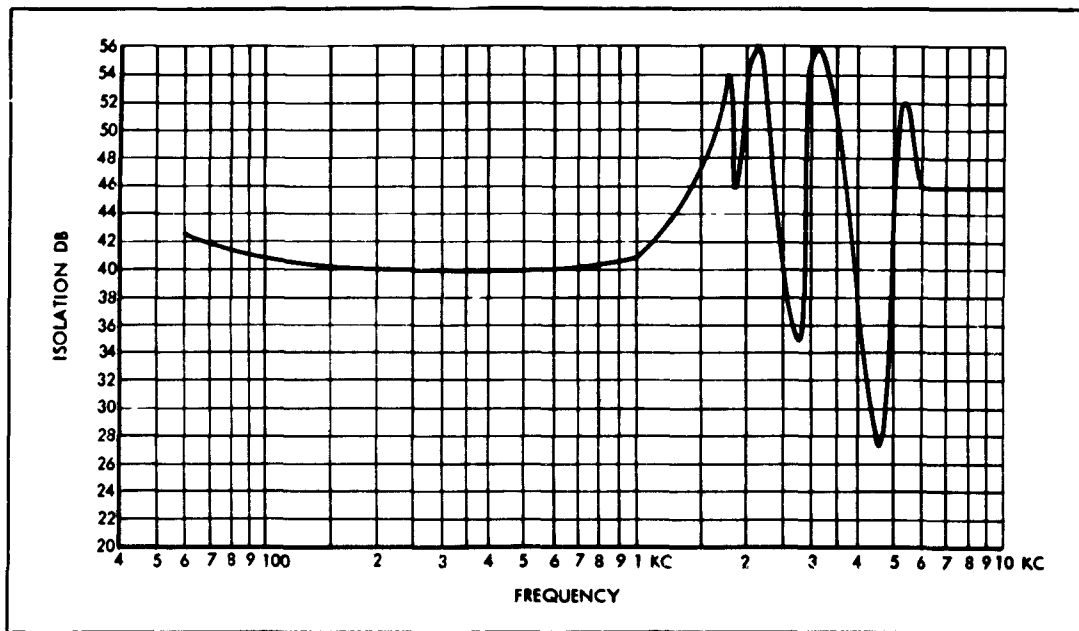

Figure 12. Receiver to Transmitter Isolation - Single Coil Hybrid.

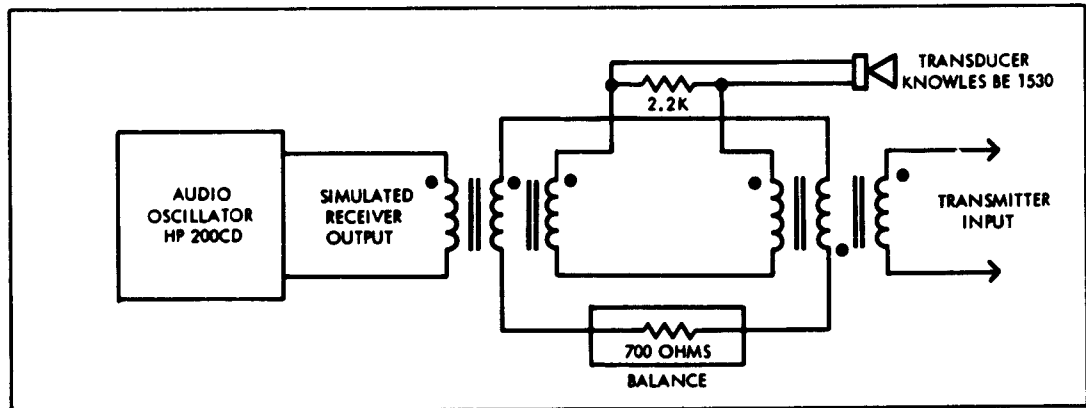

Figure 13, Hybrid Diplexer Test Setup - Two Coil.

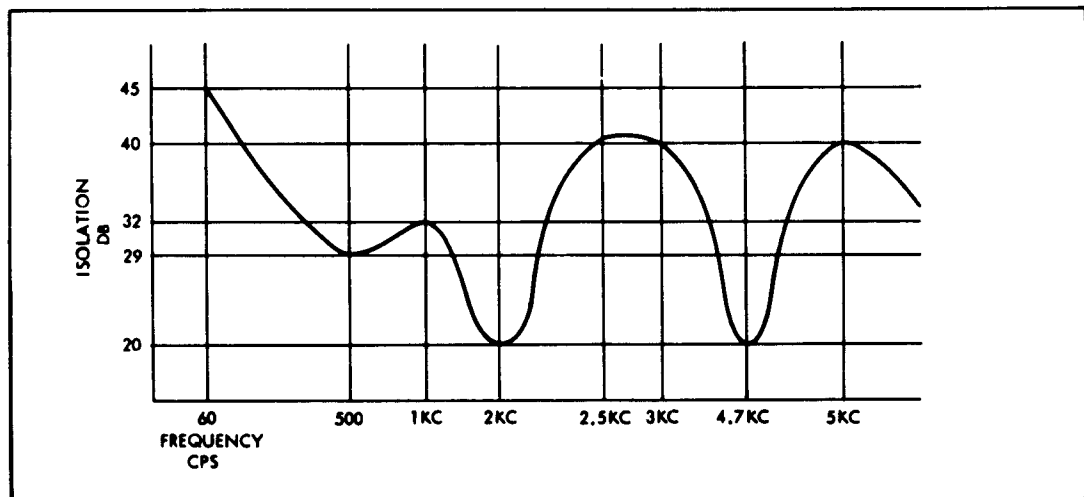

Figure 14. Receiver to Transmitter Isolation - Two Coil Hybrid.

C. Resistive Bridge Diplexer

1. Dynamic Microphone. The resistive bridge was optimized for maximum isolation throughout the voice spectrum. Frequency sweep techniques were used to speed the optimization. The circuit used with a dynamic microphone (Knowles 1531) is shown in figure 15. The curves indicate the receiver to transmitter isolation (figure 16), receiver to transducer loss (figure 17), and transducer to transmitter loss (figure 18), as a function of frequency.

2. Crystal Microphone. The resistive bridge diplexer was tested with an inexpensive crystal earphone unit in place of the dynamic unit. The optimized circuit is shown

in figure 19. The curves (figures 20, 21) indicate the advantage of utilizing a transducer with a more constant impedance characteristic.

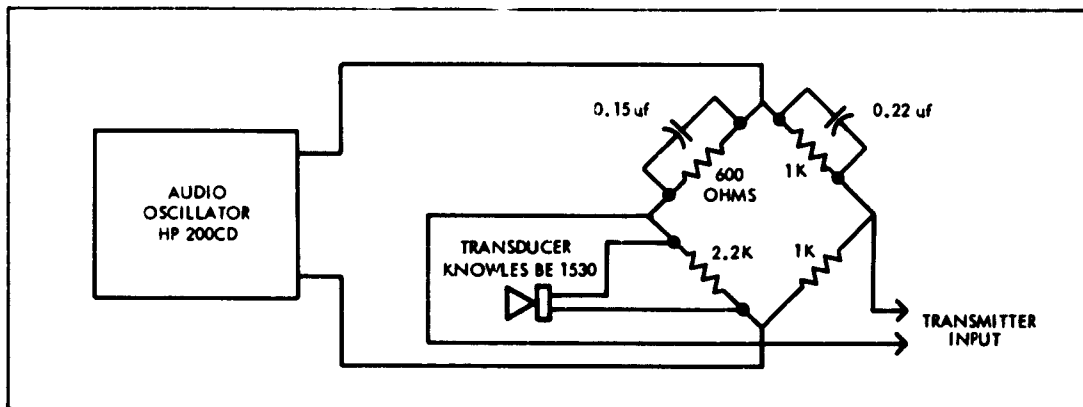

Figure 15. Resistive Bridge Diplexer.

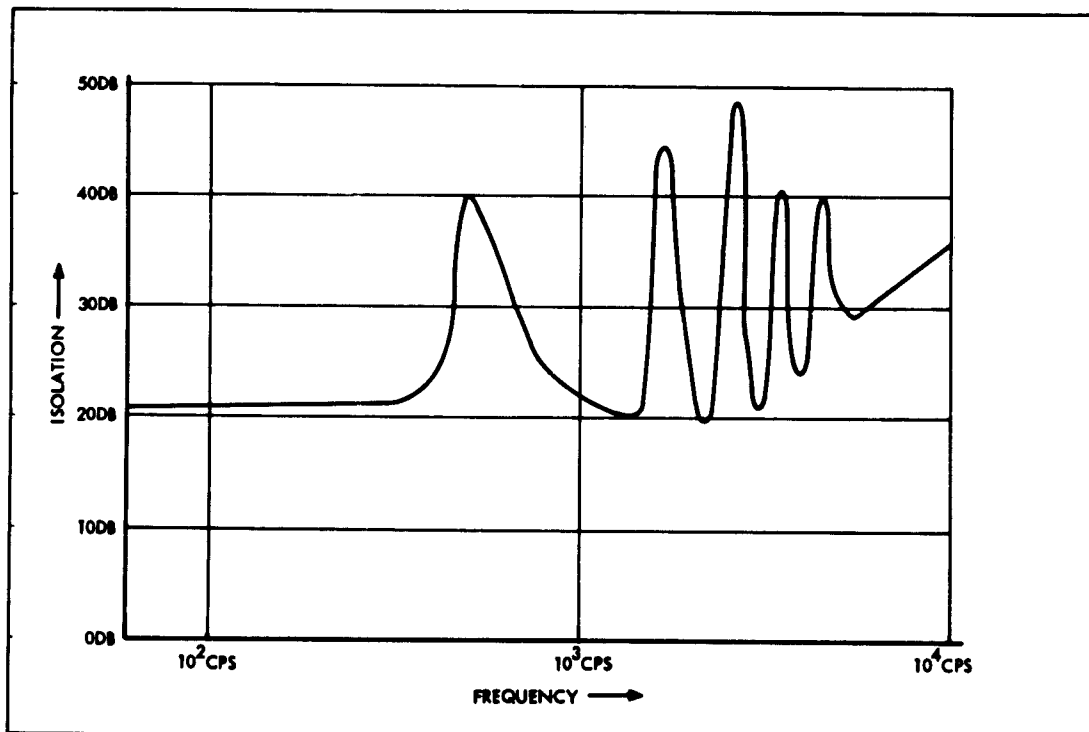

Figure 16. Resistive Bridge Diplexer - Receiver to Transmitter Isolation.

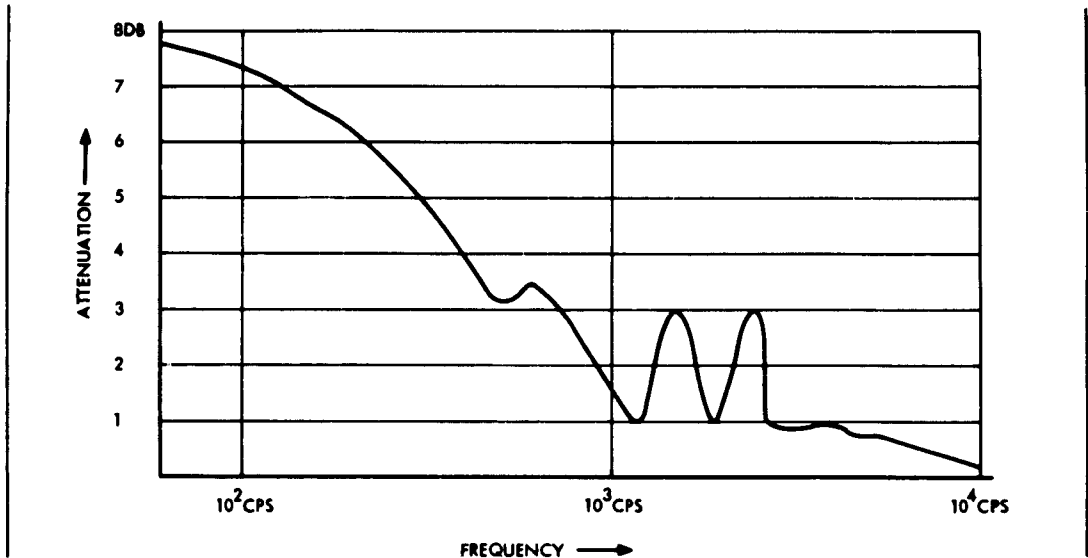

Figure 17. Resistive Bridge Diplexer - Receiver to Transducer Loss.

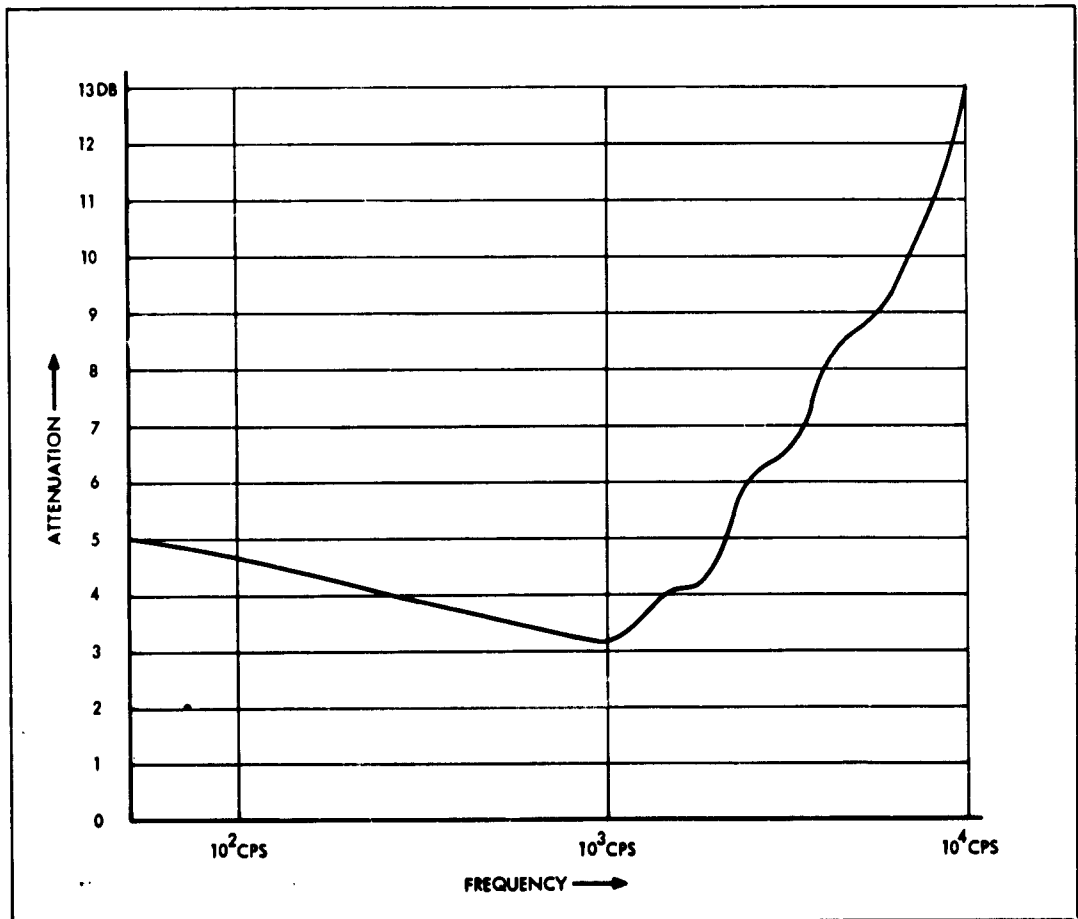

Figure 18. Resistive Bridge Diplexer - Transducer to Transmitter Loss.

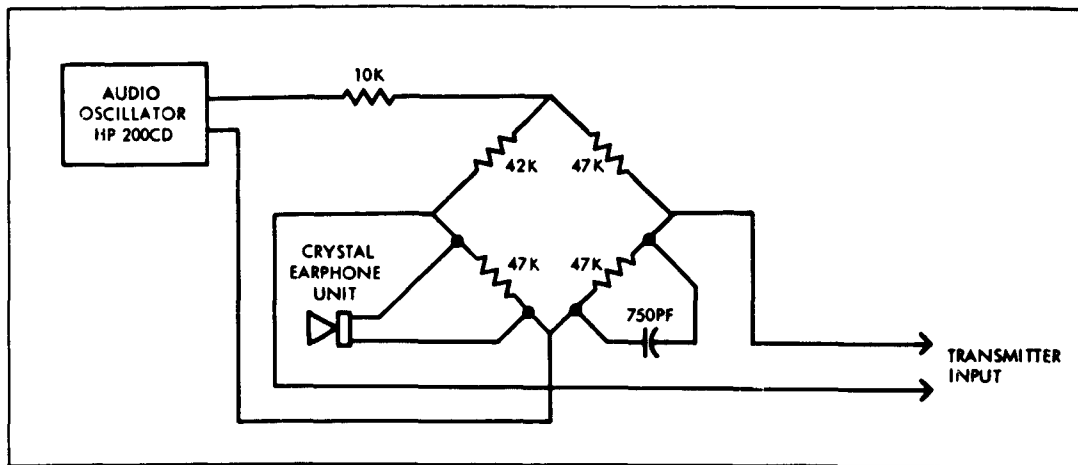

Figure 19. Resistive Bridge Diplexer - Crystal Transducer.

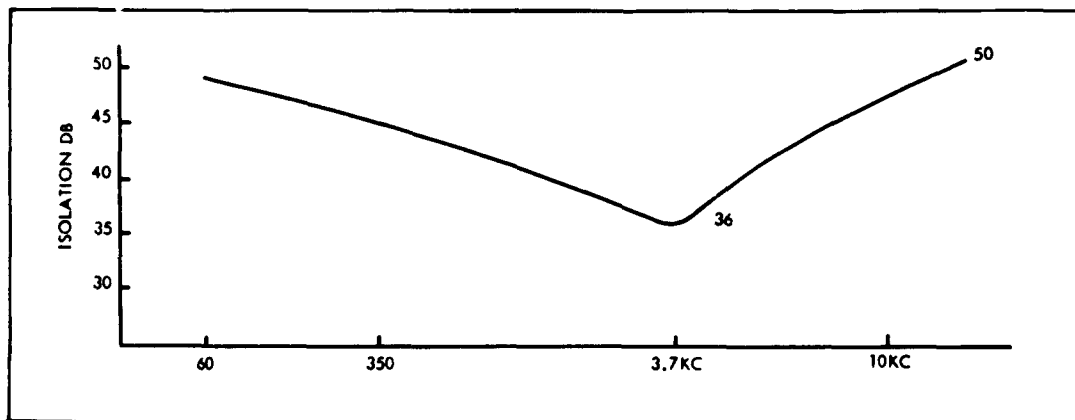

Figure 20. Resistive Bridge Diplexer - Crystal - Receiver to Transmitter Isolation.

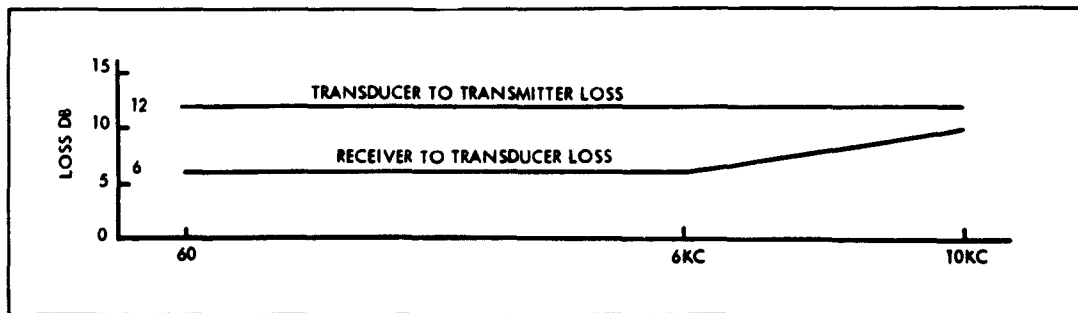

Figure 21. Resistive Bridge Diplexer-Crystal-Losses.

APPENDIX II

EAR INSERT MICROPHONE INTELLIGIBILITY TEST

Problem Statement

Communications in many noisy environments would be facilitated if an obtrusively mounted diplexer (combination microphone-receiver) were available as a replacement for the often encumbering and uncomfortable lip microphone and earphone headset equipment presently in use. Several body sites, including the teeth and the forehead (ref. 224), have been suggested as potential locations for a diplexer. Examination of the available data led Spacelabs, Inc., to the conclusion that the ear canal provides the optimum location, because of the apparently adequate bone-transmitted speech power present, combined with the superiority of the ear as an auditory input. Furthermore, it is felt that improvements can be made on previous attempts to locate a microphone in the ear (ref. 10, 133-138).

An ear canal insert microphone-receiver was designed, using a commercially available miniature hearing aid microphone as the sound transducer, and an individually-molded plastic ear canal insert as a coupling means between the sound transducer and the ear canal. Several units, fitted to laboratory personnel, were then fabricated, and a small-scale experiment designed to evaluate their performance. This appendix presents the experimental method, and results. Please note that in this appendix only, the word speaker refers to a person, while the word receiver refers to an earphone (sound producing device).

Approach

Intelligibility information transmitted through the ear canal insert units was of primary concern. Spacelabs, Inc., was interested in how well the ear inserts functioned both as microphones and receivers, how well their performance compared with the best presently available equipment, how well they performed in noisy environments, and how their performance was affected by individual speaker characteristics.

There exist many intelligibility tests ranging from examinations of the reception of isolated nonsense syllables to the reception of coherent, highly-redundant sentences.

The Fairbanks Rhyme test (ref. 54) was selected as an articulation measure on the basis of recent reports (ref. 132, 143) attesting to the ease of administering this test, its low intersubject variance, small learning effect, and good correspondance with more established, phonetically-balanced, communications tests. In the Rhyme test, the subject is presented with a test sheet consisting of 50 words lacking their initial consonants. He is asked to fill in these missing letters after listening to the speaker intoning the complete word. Several choices exist, since the word roots are all members of rhyme families; e.g. soon, moon; or heal, deal, seal. The test thus incorporates some element of the redundancy inherent in English words, and also permits a detailed compilation of troublesome consonant sounds.

The larger the experimental speaker and listener populations, the more meaningful the articulation results. The present experiment involved minimal populations, two speakers, and four listeners, and consequently its results must be accepted as more indicative than definitive. The speakers and listeners functioned within an experimental design, which, through confounding, limited listener exposure to a reasonable length testing period, yet provided adequate information on important main effects and interactions.

EAR INSERT

Figures 22 and 23 illustrate the ear insert schematically, in relation to its associated microphone, and in use. Note that during use the insert was always covered by a muff type ear defender which is not shown for clarity. The plastic ear mold was custom-made for each subject by the Royale Laboratory in Glendale, California, and, if necessary, altered until a perfect fit had been achieved.

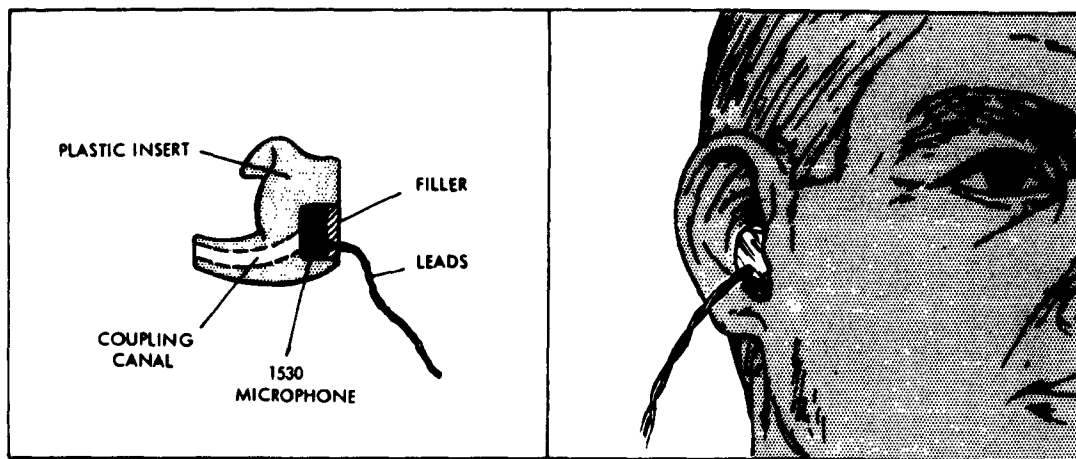

Figure 22. Ear Insert Microphone



Figure 23. Ear Insert In Place.

The hearing-aid microphone used is a Model BE 1530, manufactured by Knowles Electronics, Inc. The typical response of this unit when used as a microphone is shown in figure 24, differences among the several units employed were small. Figure 25 presents the response of the BE 1530 when used as a receiver, either directly coupled to an acoustic chamber or coupled through a 0.91-inch length of 0.12-inch ID tubing. The coupling canals used were approximately the same length, but slightly larger in mean inside diameter. Most likely, the high-frequency boost fell somewhat below that granted for the test case.

Electrical connection to the microphone was made through fine twisted leads. In use, the ear insert was always covered by a noise attenuating muff-type ear defender (Willson Sound Barrier). The leads did not noticeably interfere with its normal seal.

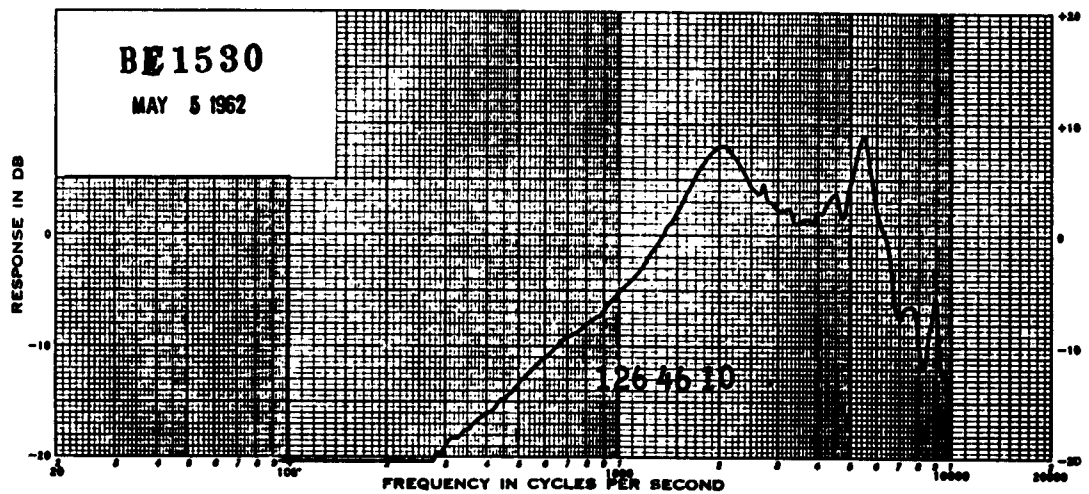

Figure 24. Response of Knowles BE 1530 as Microphone.

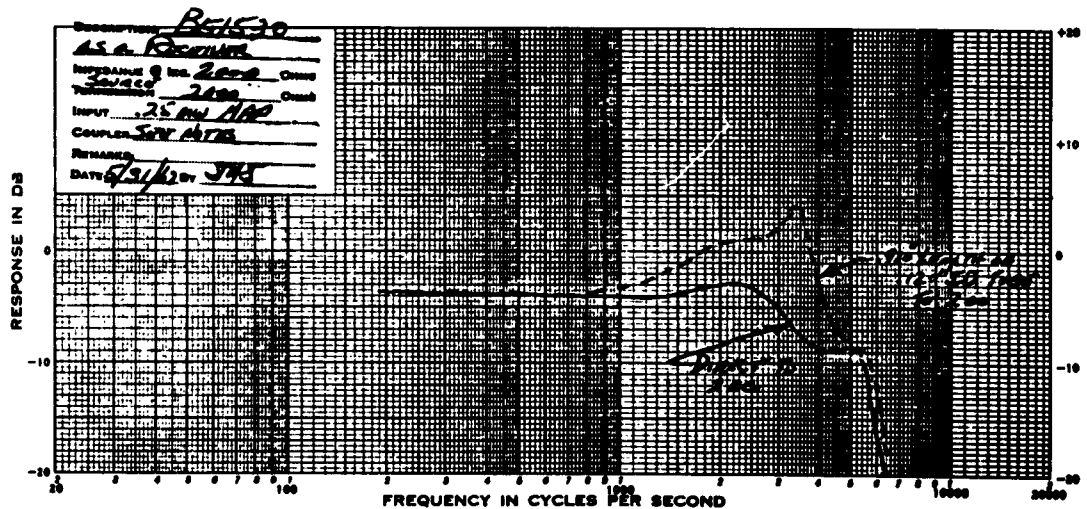

Figure 25. Response of Knowles BE 1530 as Receiver.

EXPERIMENTAL METHOD

Design: The experimental variables are summarized in Table 1. Five variables each appeared at two levels, yielding a complete factorial of $2^5 = 32$ treatments. An experimental treatment consisted of one complete 50-word test list presented under the specified combination of variables. The experimental measure applied was the percentage of words correctly identified. Each subject heard four different lists, read by a single speaker. The complete set was presented once during the morning of the test day, and once in the afternoon. The lists were assigned to the experimental treatments at random.

Subjects were not previously told the contents of the lists they would hear, and it was assumed no learning took place.

These 32 treatments were administered to four subjects, randomly assigned blocks of 8 treatments each, following a design outlined in Kempthorn (ref. 100). Table 2 summarizes this design. In this table, a variable is shown if it appears at the '1' level, and not shown if at the '0' level (the term (1) represents $a_0 b_0 c_0 d_0 e_0$). The following three effects were confounded:

- A - Difference between speakers,
- BCDE - No apparent meaning,
- ABCDE - No apparent meaning.

Thus all other main effects, as well as all two and three factor interactions, remained statistically testable at the expense of the ability to test mean differences between speakers.

The distribution of initial consonant sounds in the test vocabulary of 200 words is presented in Table 3.

TABLE 1. A SUMMARY OF EXPERIMENTAL VARIABLES

SYMBOL		LEVEL	
		0	1
A	Speaker	1	2
b	Microphone	lip	insert
c	Speaker ambient noise level	70db	110db
d	Receiver	headset	insert
e	Listener ambient noise level	70db	110db

TABLE 2. A SUMMARY OF EXPERIMENTAL TREATMENTS

SUBJECT	TREATMENT							
1	(1)	bc	bd	de	cd	ce	de	bcde
2	a	abc	abd	abe	acd	ace	ade	abcde
3	b		d	e	bed	bce	bde	cde
4	ab	ac	ad	ae	abed	abce	abde	acde

TABLE 3. DISTRIBUTION OF CONSONANTS IN THE STIMULUS VOCABULARY

CONSONANT	FREQUENCY	CONSONANT	FREQUENCY
s	22	l	13
t	18	f	12
b	17	d	11
m	16	n	8
l	16	g	7
p	14	d ₃	3
r	13	v	1
w	14	i	1
k	13	z	1

The complete vocabulary can be found in reference 54, lists RT-1 through RT-4.

Experimental Variables: The insert microphone and receiver unit has been described in a previous section. The lip microphone and headset used for comparison purposes were, respectively, a Roanwell M87/AIC dynamic noise-cancelling microphone, and a Model H143/AIC earphone in an MX-2508/AIC headset. Because speakers and listeners were fitted with inserts only for the right ear, the left earphone of the headset was disconnected during the test sessions.

The normal noise level within the test enclosure formed the low-noise ambient environment. The high-noise ambient condition was produced by playing a GR Random Noise generator with filtered output into a public address amplification system having dual-speaker output. Figure 26 presents the resulting spectrum as measured at the combination speaker-listener station with an H. H. Scott, Inc. Model 412 sound level meter used in conjunction with an H. H. Scott, Inc. Model 420-A sound analyzer. This spectrum is similar to many previously reported for aircraft and rocket noise (ref. 71, 205).

Subjects: The two speakers were both familiar with the test material, and neither had any marked abnormalities of accent, inflection, or delivery. Three men and one woman constituted the listening group. Audiometric subject data were not available, but no listener reported any hearing deficiency. The subjects were judged to have equivalent familiarity with the rhyme words, but were not familiar with the actual test material.

Apparatus and Procedure: A schematic diagram of the experimental apparatus is shown in figure 27. Each speaker's lists were simultaneously recorded through the lip microphone and through the ear insert microphone. An external VU meter, matched to

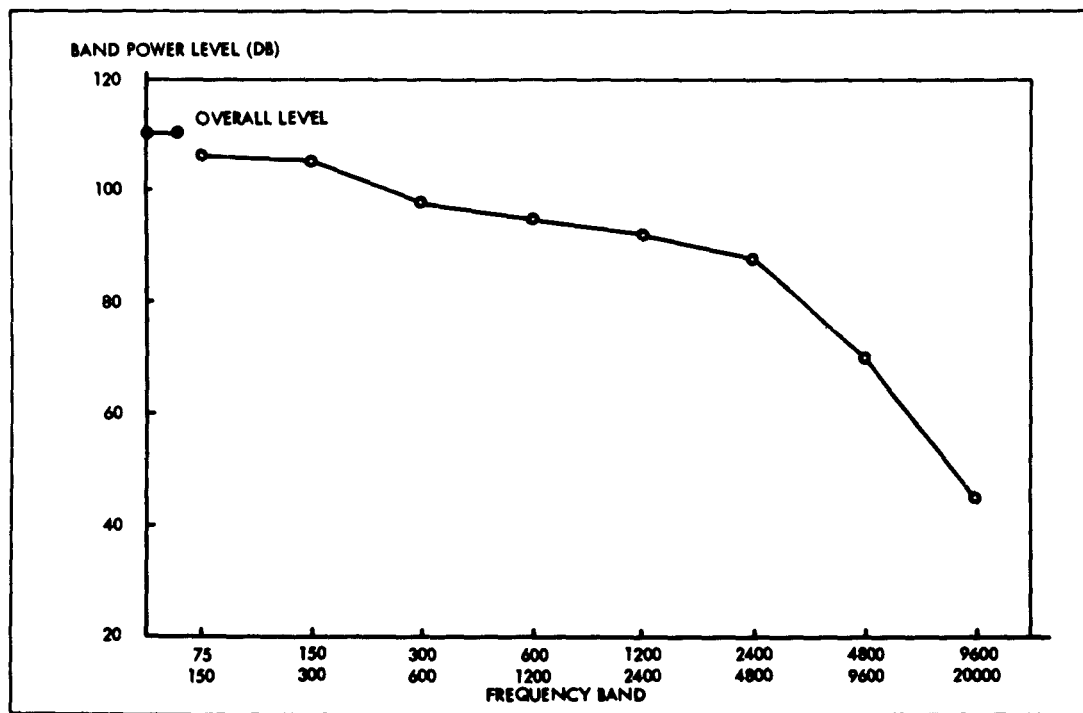

Figure 26. Sound Power Spectrum of High-Noise Environment Plotted by Octave Band.

the recording level meter of the tape recorder, was attached to the output of the noise cancelling lip microphone channel. The speaker monitored this external meter as he read the lists, endeavoring to maintain peak word power at a constant preset optimum recording level. This procedure was facilitated by speaking the cue word "write" before each test word. Recording level on the insert microphone was likewise set to an optimum point at the initiation of reading. Neither level was changed during the speaking session. Two speaker lists were recorded in quiet and two in noise. For each set of two, one list was arbitrarily designated the "lip microphone" list and the other the "insert microphone" list.

During administration of the Rhyme Test, the listeners received the test words from either the lip or insert channel, and listened either through headsets or an ear protector covered insert. A volume control was made available to the listeners and they were instructed to adjust the incoming sound to a preferred level for each condition. Each test list was preceded by an identification phrase which could be used to determine preferred loudness and, as mentioned, each test word was preceded by the cue "write."

To exemplify the test procedure: Assume the treatment to be administered is 'abde'. (This can also be written a, b, c₀, d, e.) In this case, the list placed on the tape recorder would have been recorded by speaker 2 in a low-noise ambient. The listener would listen to the ear-insert channel using an ear-insert receiver in a high-

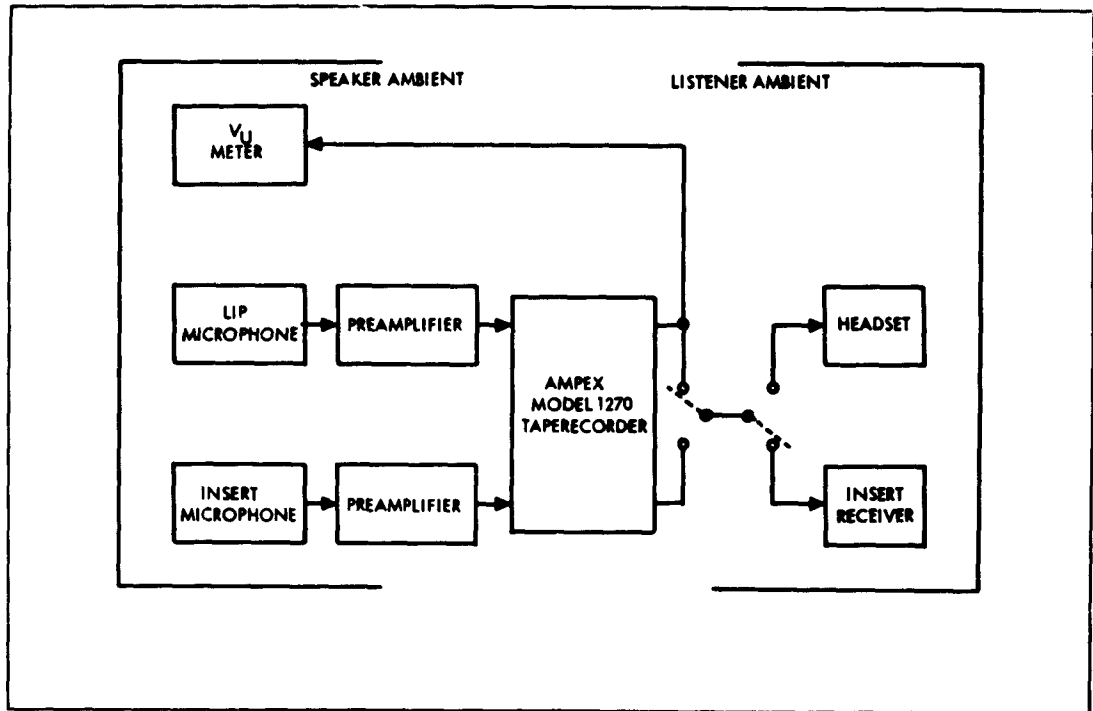

Figure 27. Experimental Apparatus.

noise environment.

Analysis: The design was analysed as outlined in Kempthorn (ref. 100), using analysis of variance techniques. The analysis of variance table is presented in Table 4.

TABLE 4. ANALYSIS OF VARIANCE SUMMARY

SOURCE	d.f	SS	MS
Among Blocks (confounded Effects)	3	269.8	
Treatments			
(Unconfounded Effects, 2 and 3 factor interactions)	24	1415.0	
Error			
(Unconfounded 4 and 5 factor interactions)	4	116.0	29.0
TOTAL; 31			

An estimate of the error variance was obtained by combining the sum of squares of the higher order interactions. The corresponding estimates of the main effects and lower order interactions, each having a 1 d.f., were individually tested against this error term. In this case, an F test with 1 and 4 d.f. or a 't' test with 4 d.f. were equivalent tests. Those effects which emerged significant are summarized in Table 5. In the results section, the higher order interaction effects are plotted which were not embedded in a third order interaction. That is, if ADE is a significant effect, DE is almost certain to be one also by the present method of analysis. Thus the plots of ADE and ABD contain the information enabling us to envision DE and BD. Similarly the interactions BC and BE clarify the differences within the significant main effects B, C, and E.

TABLE 5. A SUMMARY OF SIGNIFICANT EFFECTS

EFFECT	LEVEL OF SIGNIFICANCE	INTERPRETATION
B	.01	Microphones differ
C	.01	Speaker ambient noise influences discrimination
E	.01	Listener ambient noise influences discrimination
BC	.02	Speaker ambient affects microphones differently
BE	.05	Listener ambient affects microphones differently
DE	.02	Listener ambient affects receivers differently
BD	.05	Performance of mikes differs with receiver used
ADE	.02	Receivers performance in listener noise depends on speaker
ABD	.05	Combined performance of mikes and receivers depends on speaker

RESULTS

Figure 28 graphically presents the significant interaction between receivers, listening ambient, and speaker. Although the interaction effect is more marked for speaker 2 than for speaker 1, the differential relations are largely the same for both speakers. In quiet, the headset receiver appears to slightly outperform the insert. In noise, however, the intelligibility scores observed for the insert exceed those recorded for the standard headset - slightly so for speaker 1 and greatly so for speaker 2.

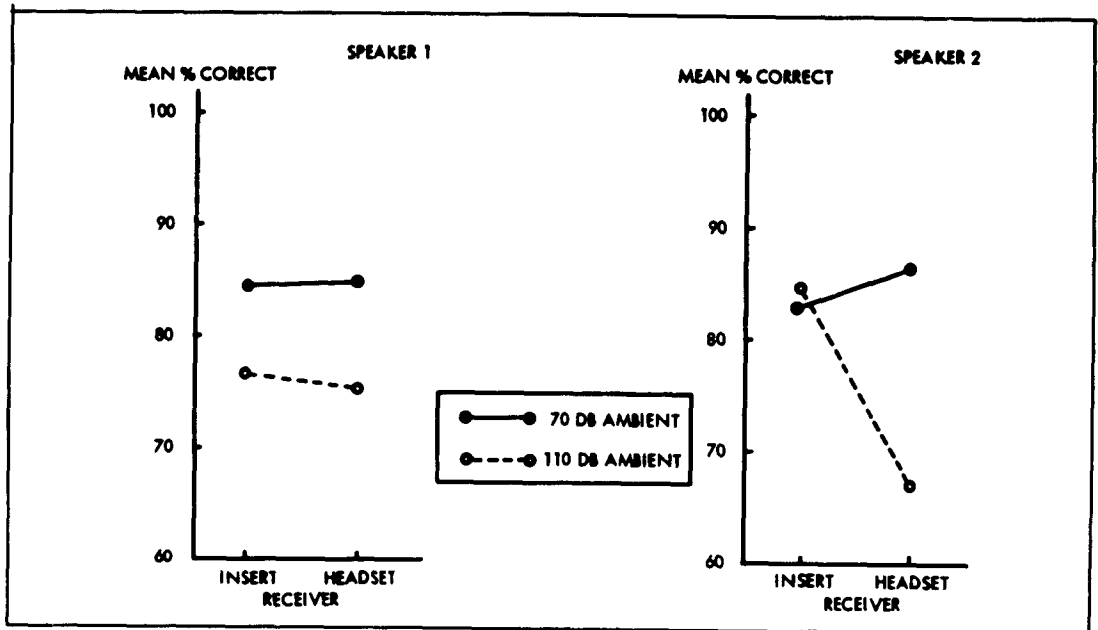

Figure 28. Differences in the Performance of Receivers as a Function of Listening Environment and of Speaker.

Considering, in figure 29, the effect of speaker on differences in the performance of microphone-receiver combinations, we again see a greater variability for speaker 2, but also an equivalence of effect for the two speakers. Two factors are evident; (1) the lip microphone, on the average, provides higher intelligibility than does the insert; and (2) combinations of insert and standard units do not perform as well as unmixed systems. That is, the lip microphone appears to function slightly better when used with a headset, and performance of the insert microphone is definitely improved by coupling it with an insert receiver.

The figures 30 and 31 explain the relatively poor performance of the insert microphone in this study. Somewhat below the lip microphone in quiet, the insert microphone deteriorates radically as soon as a noise source is introduced into the system. The almost perfect correspondence of figures 30 and 31 indicates that it is immaterial at what point in the system noise appears, the average number of words correctly identified remains virtually the same for noise surrounding the speaker or the listener. It is seen that noise also affected lip microphone intelligibility scores, but only to a slight extent. This point is further emphasized by Table 6, which presents average percent correct word discrimination scores for the two microphones when no noise sources were present, one noise source (either in the speaker or listener environment) was present, or two noise sources (both in the speaker and listener environments) were present.

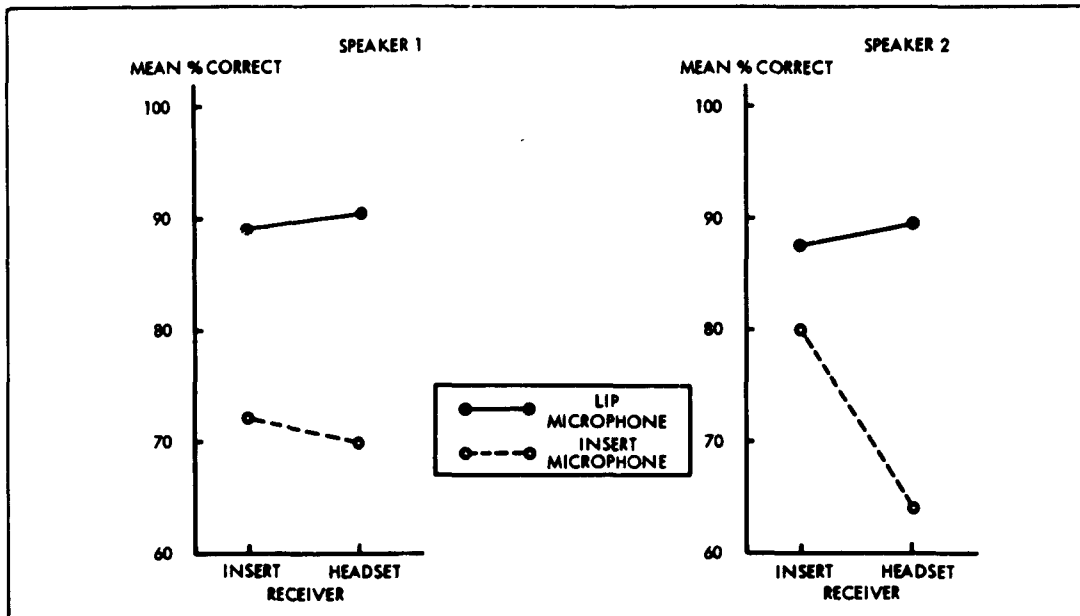

Figure 29. Differences in the Performance of Microphone-Receiver Combinations as a Function of Speaker.

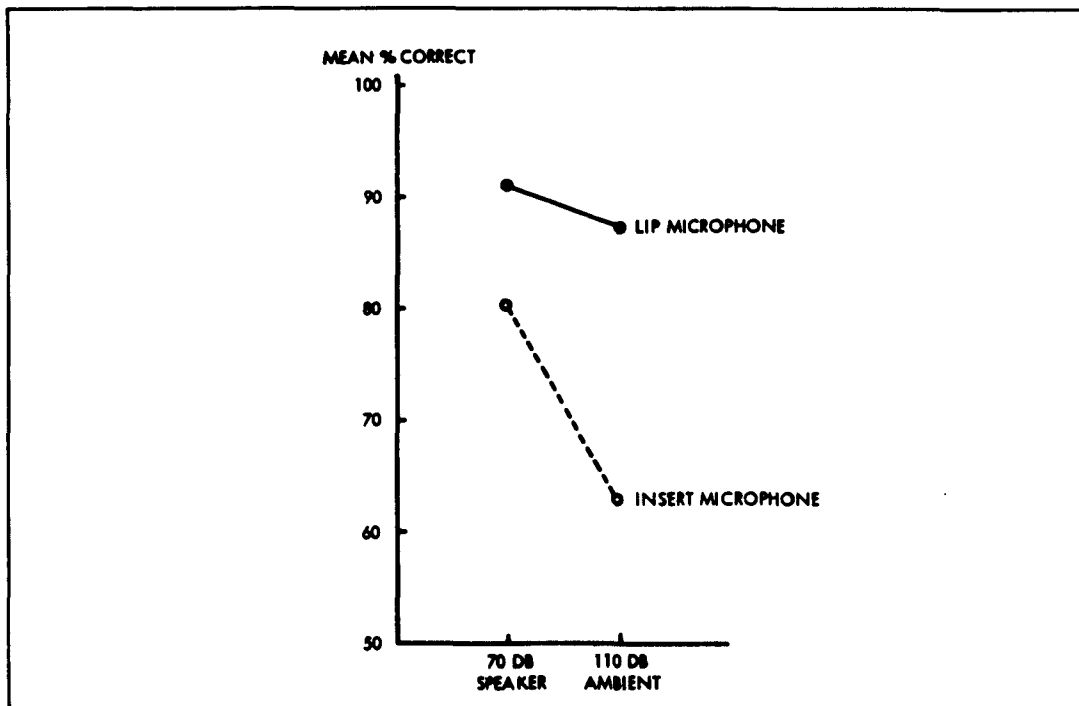

Figure 30. The Effect of Speaker Noise Environment on Microphone Performance.

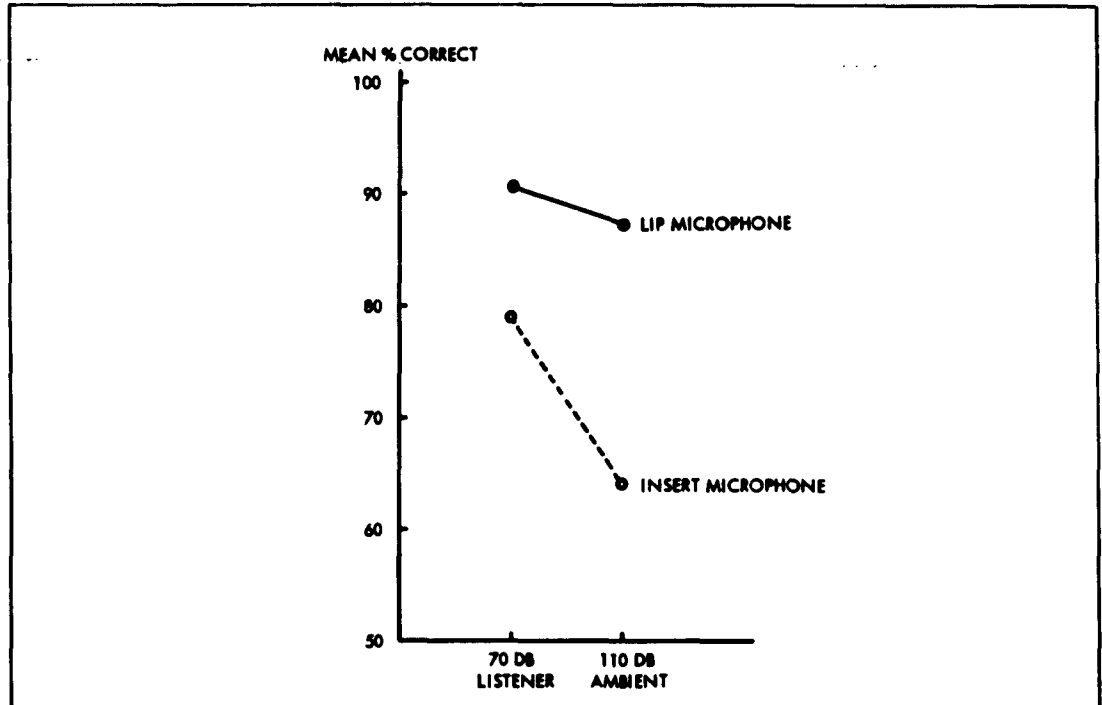

Figure 31. The Effect of Listener Noise Environment on Microphone Performance.

TABLE 6. A SUMMARY OF MICROPHONE PERFORMANCE IN NOISE

NOISE AMBIENT	MICROPHONE	
	Lip Microphone	Insert Microphone
No Noise Sources	92.5	83.5
One Noise Source	88.8	75.0
Two Noise Sources	86.0	52.5

In figures 32 and 33 are plotted initial consonant discrimination scores for the insert and lip microphone, respectively. Two scores (percent correct) are given for each consonant, one associated with the insert receiver, and the other with the headphones. Two previously noted facts are immediately evident; (1) the overall performance of the lip microphone exceeded that of the insert; and (2) performance of the insert microphone improved when it was used with an insert receiver. In addition, discrimination differences among consonants were more marked for the insert microphone. The sounds |k| and |p| gave the most trouble with this unit, and the sounds |w|, |m| and |l| presented the least difficulty. This follows expectations, since |k| and |p| are both stops, depending almost solely on changes in the air stream leaving the mouth, changes which are transmitted poorly by bone conduction to the ear canal.

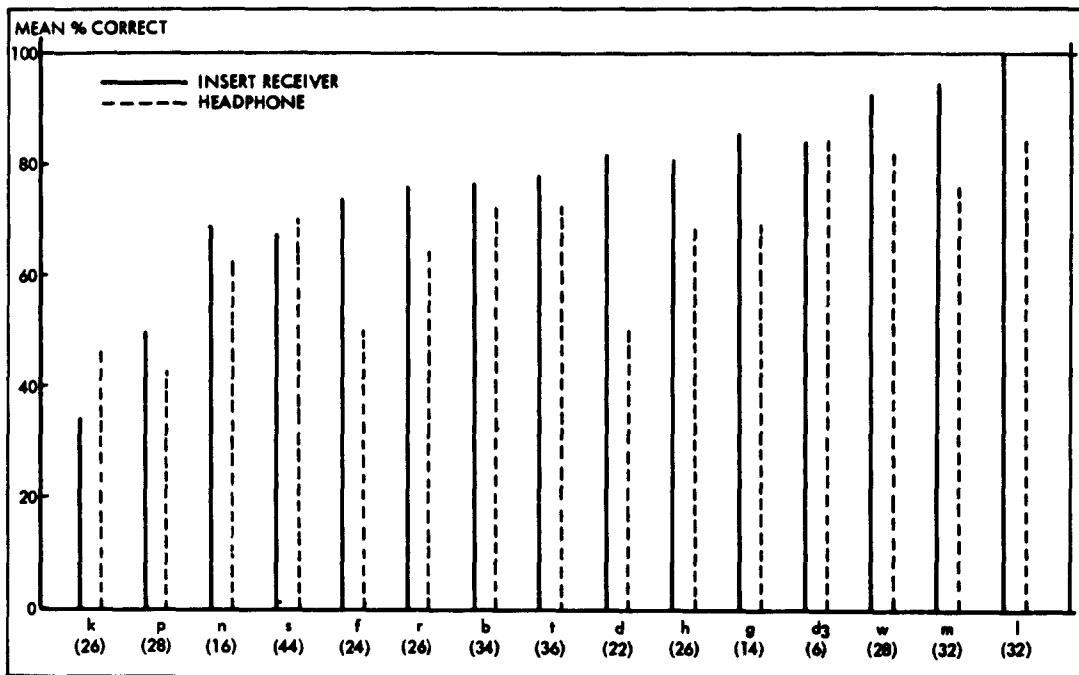

Figure 32. Insert Microphone Performance as a Function of Initial Consonant.

The picture differed radically for the lip microphone. Here, |n|, |g|, |m|, and |t| were most poorly recognized. These sounds depending heavily on throat reverberation. The |k| and |p| airstream sounds, on the other hand, were apparently clearly discriminated.

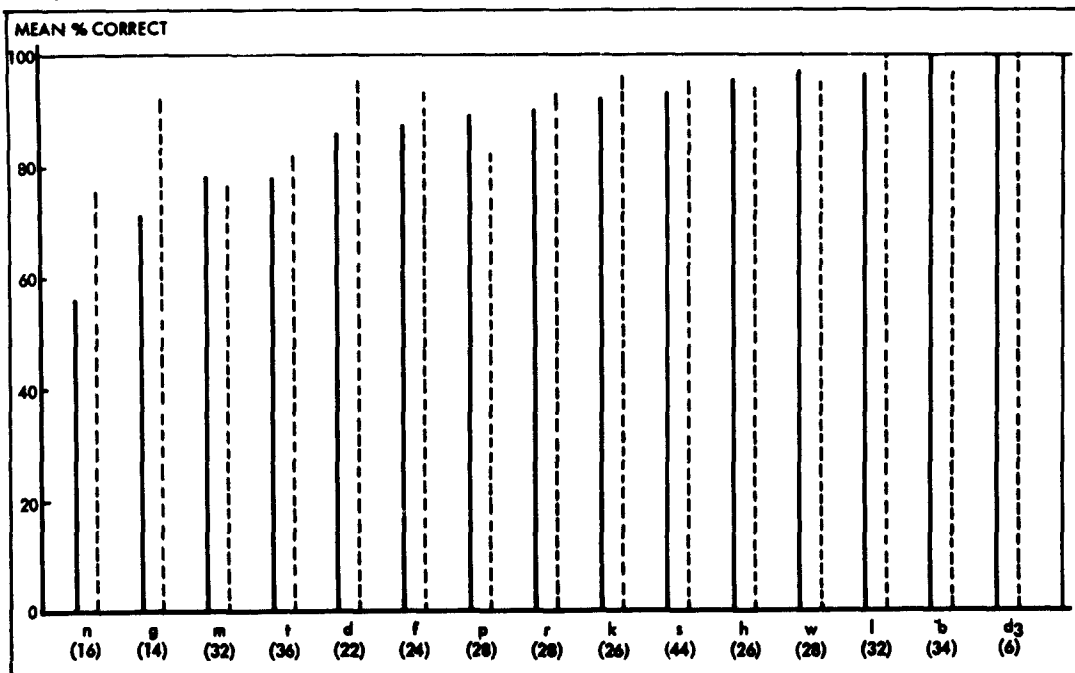

Figure 33. Lip Microphone Performance as a Function of Initial Consonant.

APPENDIX III

ELECTROPHONIC HEARING TESTS

Tests of electrophonic hearing were conducted to determine the loudness obtainable. The equipment setup is shown in figure 34. Room noise averaged approximately 60 db measured on the C scale of a Scott, Model 412 Sound Level Meter. In addition, the ears were covered with Wilson Sound Barrier Protectors. The first experiment was conducted without the dc bias. The active electrode consisted of an insulated wire with about 1/2 inch bare. The bare portion was carefully covered with a wad of cotton, soaked in saline, and placed in the external meatus. The indifferent electrode was a standard Welch ECG cup electrode (adult size), used with electrode paste, located on the forearm. A very limited dynamic range was noted. The threshold of pain was reached at approximately 1.4 volts AC while the hearing threshold was about 1.0 volts AC. The second experiment included the addition of DC bias which produced little change in subjective effect. The experiment was repeated with cotton covered active electrode replaced by a wire dipped in a saline filled meatus. No change in effect was noted.

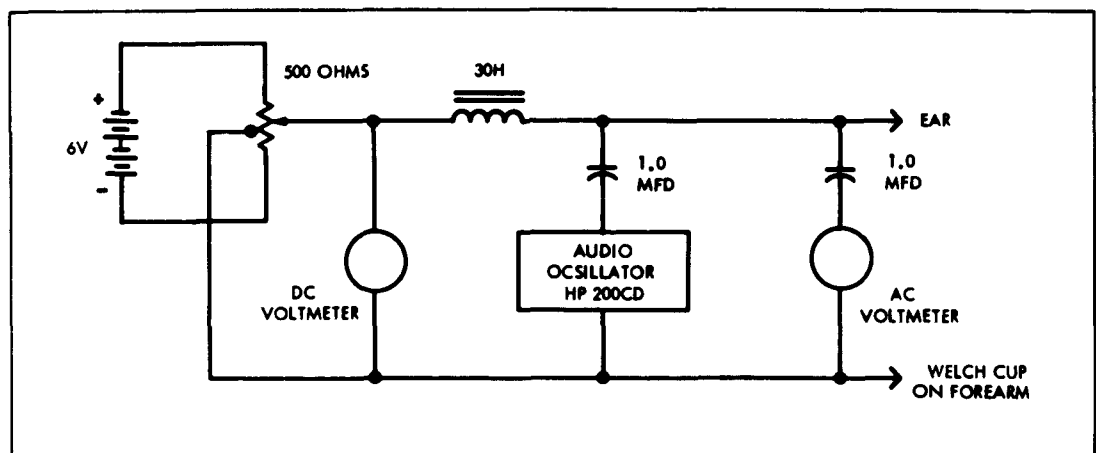

Figure 34. Electrophonic Hearing Test Setup.

At best, the sound was difficult to hear unless the frequency was wobbled slightly up and down. Audio signal (music and speech) from an FM receiver was substituted for the oscillator output. Even though the voltage levels were similar, no meaningful intelligence could be heard. This was undoubtedly caused by the speech and music peaks being so much higher than the average levels that pain resulted before the necessary average level could be reached. The music and speech voltage levels were monitored with a Tektronix 502 oscilloscope in place of the AC voltmeter and 1 mfd capacitor.

From these tests it was obvious that quantitative data could be gathered only with the aid of a sound proof room. Since the perceived sound level was so low it was decided that no further tests were warranted.

BIBLIOGRAPHY

1. Abraham, Lewis, Brussels, Belgium, Acoustic Apparatus for the Deaf, U.S. Patent No. 2, 230, 397, Application Date 4 February 1941.
2. Albanese, A. P., Wand, N., Zivatofsky, B., Zolotnitsky, L., Speech Bandwidth Compression System (Scanning Filter), AD 268 351, Final Report Contract DA-36-039-sc-85-140 Prepared for U.S. Army Signal Research and Development Laboratory, Fort Monmouth, New Jersey by PRD Electronics, Inc., PRD Report 341-0911FR, September 1961.
3. Angeluscheff, Z. D., "Ultrasonics and Progressive Deafness," The Journal of the Acoustical Society of America, 26:142, 942, 1954.
4. Arapova, A. and Gersuni, G., "On the Frequency of Alternating Current and the Pitch of the Tone During Electrical Stimulation on the Auditory Apparatus," Techn Physics USSR 5:447-462: 1938.
5. Ataev, M. M., "Reduction in Sensitivity of Auditory Analyzer Under the Effect of Powerful Sound Stimuli," Biophysics, 3:62+68, 1958.
6. Barto, John P., "A Cooperative Digital and Voice System," Electronic Industries, 21:2:190-192, February 1962.
7. Baxt, Kenneth M., Communication Apparatus, U.S. Patent No. 3, 029, 307, Application Date 21 May, 1959.
8. Beranek, Leo L., "The Design of Speech Communication Systems," IRE Proc., 35:880-890, September 1947.
9. Black, John W., Tolhurst, Gilbert C. and Morrill, S. N., Applications of Multiple-Choice Speech Intelligibility Tests in the Evaluation and Use of Voice Communication Equipment. ASTIA AD 248 02. U.S. Naval School of Aviation Medicine - Joint Project Report No. 19, 13 November 1953.
10. Black, R. D., "Ear Insert Microphone," J. Acous. Soc. Amer, 29:260-264, February 1957.
11. Bliss, J. C. and Kotovsky, K., Tactual Perception of Visual Information, Stanford Research Inst. Interim Report 1, Contract AF33(657)-8824, September 1962.
12. Bolt, R. H., Likasik, S. J., Nolle, A. W. and Frost, A. D., Handbook of Acoustic Noise Control, Vol. 1, December 1952; Vol. 2, June 1953, and Suppl. 1, April 1955, Bolt Baranek and Newman,
13. Bryan, G. W., Jr., Sound Powered Radio Transmitter, U.S. Patent No. 2, 981, 833, Application Date 25 April, 1961.
14. Bullock, T. H., "Comparative Aspects of Some Biological Transducers," Federation Proceedings, 12(3):666-672, September 1953.

15. Burgeat, M. and Hirsh, I. J., "Changes in Masking With Time," JAcous. Soc. Am., 33:963-965, July 1961.
16. Butler, R. A., Diamond, I. T. and Neff, W. D., "Role of Auditory Cortex in Discrimination of Changes," Journal of Neurophysiology, 20(1): 108-120, 1957.
17. Cade, C. M., "Eighty Years of Photophones," British Communications and Electronics, 112-115, February 1962.
18. Carnes, H. E., M.D. (Editor), "Music and Medicine," Therapeutic Notes, Parke Davis, 68:302-307, November-December 1961.
19. Cherry, Colin, "Two Ears - But One World!" Sensory Communication, Wiley 1961.
20. Chocholle, R., "Sensation Auditive Engendre Par Action d'ondes Rectangulaires," Cashiers d'Acoustique, in Ann. Telecom, 5:237-42, June 1950.
21. Chromet, M., Close, R., Fogel, L., Keen, H., and Schwartz, M., "Pseudo-Redundancy in Communications Systems," Topics in Electronics, Airborne Instruments Laboratory Vol. 3, 1962.
22. Clark, Welden, of Bolt, Beranek and Newman, Inc., Reaction to Aircraft Noise, ASD-TDR 61-610, November 1961.
23. Clark, Welden E., of Bolt, Beranek and Newman, Inc., Noise From Aircraft Operations, ASD-TDR 61-611, November 1961.
24. Coutler, D. C., Early, D. M., and Irons, R. E., A Digitized Speech Compression System, ASTIA AD 266 969, Melpar, Inc., Falls Church, Virginia, September 1961.
25. Craik, K. J. W., Rawdon-Smith, A. E. and Sturdy, R. S., "Note on the Effect of A. C. on the Human Ear," Physiol. Soc. Proc., May 1937, 3-5 (Bound With J1. Physiol., Vol. 90).
26. Davis, H., Tasaki, I. and Goldstein, R., "The Peripheral Origin of Activity With Reference to the Ear," Cold Spring Harbor Symposia on Quantitative Biology, 143-154, 1952.
27. Davis, H., "Biologic Transducers," Federation Proceedings, 12(3): 661-665, 1953.
28. Davis, Hallowell, "Energy into Nerve Impulses: Hearing," Medical Bulletin, St. Louis University, 5:43-48, March 1953.
29. Davis, H., "Excitation of Nerve Impulses in the Cochlea," Ann. Otol. Rhin. & Laryngol., 63:469-480, June 1954.
30. Davis, H., "Initiation of Nerve Impulses in the Cochlea and other Mechanoreceptors," J. of Cellular and Comparative Physiology, 1955, 46(2)369-370.

31. Davis, H., "A Mechano-Electrical Theory of Cochlear Action," Annals of Otolaryngology, Rhinology and Laryngology, 67(3):789-801, 1958.
32. Davis, H., Deatherage, B. H., Eldredge, D. H. and Smith, C. A., "Summating Potentials of the Cochlea," American J. of Physiology, 195(2):251, 1958.
33. Davis, H., "Transmission and Transduction in the Cochlea," The Laryngoscope, 68(3):359-382, 1958.
34. Davis, Hallowell, "Peripheral Coding of Auditory Information," Sensory Communication, Wiley, 1961.
35. Deatherage, Bruce H., Jeffress, Lloyd A., and Blodgett, Hugh C., "Note on the Audibility of Intense Ultrasonic Sound," J. Acous. Soc. Amer., 26:582, 1954.
36. Deatherage, Bruce H., Davis, H. and Eldredge, D. H., "Physiological Evidence for the Masking of Low Frequencies to High," J. of the Acous. Soc. Amer., 29(1):132-137, 1957.
37. Deatherage, Bruce H., Rosenblat, B., Fernandex, C., Kimura, R., and Smith, C. A., "Modification of Cochlear Potentials Produced by Streptomycin Poisoning and by Extensive Venous Obstruction," Laryngoscope, 58(3):596-627, March 1958.
38. Deatherage, Bruce H., Eldredge, D. H., and Davis, H., "Latency of Action Potentials in the Cochlea of the Guinea Pig," J. Acous. Soc. Amer., 31(4):477-486, 1959.
39. Derbyshire, A. M., Fraser, A. A., McDermott, M., and Bridge, A., "Audiometric Measurements by Electroencephalography," Electroencephalography and Clinical Neurophysiology, 8:467-478, 1956.
40. Djourno, A., Eyries, C., and Vallancien, P., "Electrical Excitation of the Cochlear Nerve in Man by Induction at a Distance With the Aid of a Micro-Coil Included in the Fixture," Compt. Rend. Soc. Biol., 151(3):423-425, 1957.
41. Djourno, A., Eyries, C., and Vallancien, P., "Preliminary Attempts of Electrical Excitation of the Auditory Nerve in Man by Permanently Inserted Micro-Apparatus," Bull. Acad. Nat'l. Med. Paris, 141:21-23, 481-483, July 1957.
42. Doyle, John B., Jr., M.D., Experimental and Clinical Significance of Acoustic Nerve Stimulation in the Deaf Patient. Univ. of So. Calif. School of Medicine, Los Angeles, California, November 27, 1962.
43. Dukes, J. M. C., "Effect of Severe Amplitude Limitation on Certain Types of Random Signal: A Clue to the Intelligibility of 'Infinitely' Clipped Speech," IEE Journal, Part C, 88-97, 1955.

44. Dyer, William R., The Masking of Speech by High- and Low-Pass Noise, RADC-TDR 62-298, N62-15521, July 1962.
45. Eastman, R. O., A New Pulse Modulated Speech Communications System Having a Minimum Duty Cycle, U.S. Navy Electronics Laboratory, Radar Branch, 1961.
46. Edsall, G., "Electronic Stimulators," Proceedings IRE, Australia, p.459, July 1960.
47. Efrussi, M. M., "Modern Audiometers and Hearing Aids," Acoustic Institute, Academy of Sciences, USSR, Moscow, Translated from Akusticheskil Zhurnal, Vol. 7, No. 4, 403-414, October-December, 1961.
48. Egan, J. P., Articulation Testing Methods II, ASTIA AD 205 04, OSRD Report #3802, Research on Sound Control, Psycho-Acoustic Lab., Harvard Univ., Cambridge, Mass., 1 November 1944.
49. Eldredge, D. H., and Covell, W. P., "A Laboratory Method for the Study of Acoustic Trauma," The Laryngoscope, 68(3):465-477, March 1958.
50. Ellersick, Fred W., "Data Compactors for Space Vehicles," IBM Communications Systems Center, Rockville, Maryland. IRE Tech. Papers Presented at the Eighth East Coast Conference on Aerospace and Navigational Electronics, Baltimore, Maryland, October 23-25, 1961.
51. Elliott, L. L., Backward Masking: Monotic and Dichotic Conditions, SAM-TDR-62-76, June 1962.
52. Embleton, T. F. W., and Theissen, G. J., "Mechnaical Pressure-Gradient-to-Pressure," J. Acoust. Soc. Amer., Vol. 33:7, July 1961.
53. Estes, N. N. and Moore, J. J., Development of a Noise Exposure Meter, MRL-TDR 62-56, June 1962.
54. Fairbanks, G., "Test of Phonemic Differentiation: The Rhyme Test," J. Acous. Soc. Amer., 30:596-600, July 1958.
55. Fant, C. G. M., "Speech Analysis and Synthesis," Royal Institute of Technology, Speech Transmission Lab., Stockholm, Sweden, AF 268 482.
56. Fawcett, H. H., "Speech Transmission Through Respiratory Protective Devices," Industrial Hygiene J., 22(3):170-174, June 1961.
57. Fernandez, B. E., "Electrical Injury of the Cochlea of the Guinea Pig," Proc. Soc. Exp. Biol., New York, 75:432-455, 1950.
58. Fernandez, C., "The Innervation of the Cochlea (Guinea Pig)," The Laryngoscope, 61(12):1152-1172, December 1951.
59. Fletcher, H., Speech and Hearing in Communication, Van Nostrand, 1953.
60. Fletcher, J. L., A Survey of Hearing Losses Among Armor Personnel, AMRL 282, Fort Knox, Ky., 29 August 1956.

61. Fletcher, J. L. and Silver, C. A., Attenuation Characteristics of Four Ear Protective Devices., AMRL Report No. 322, Fort Knox, Ky., 4 September 1957.
62. Fletcher, J. L., Hearing Losses of Personnel Exposed to Impulse and Steady State Noise, ARML Report No. 355, Fort Knox, Ky., 27 May 1958.
63. Fletcher, John L., Comparison of Attenuation Characteristics of the Acoustic Reflex and the V-51R Earplug, AMRL Report No. 397, Fort Knox, Ky., 6 July 1959.
64. Fletcher, J. L. and Riopelle, A. J., The Protective Effect of the Acoustic Reflex for Impulsive Noises., AMRL Report No. 396, Fort Knox, Ky., 6 July 1959.
65. Fletcher, J. L., TTS Following Prolonged Exposure to Acoustic Reflex Eliciting Stimuli, AMRL Report No. 473, Fort Knox, Ky., 28 February 1961.
66. Fletcher, J. L. and Loeb, M., Contralateral Threshold Shift and Reduction in Temporary Threshold Shift as Indices of Acoustic Reflex Action, AMRL Report No. 490, Fort Knox, Ky., 22 August 1961.
67. Fletcher, J. L., A Field Evaluation of the Acoustic Reflex Ear Defender System, AMRL Report No. 524, Fort Knox, Ky., 21 December 1961.
68. Fletcher, J. L., w/tech. asst. of Schmidt, E. A., Acoustic Reflex Response to High Intensities of Impulse Noise and to Noise and Click Stimuli, AMRL Report No. 527, Fort Knox, Ky., 22 December 1961.
69. Fletcher, J. L. and Loeb, M., w/tech. asst. of Andrew, L., Friedman, S. and Stern, H., Free Field Threshold Shift and Temporary Threshold Shift Reduction as Measures of Efficiency of Ear Protective Devices, AMRL Report No. 539, Ft. Knox, Ky., 28 May 1962.
70. Flottorp, Gordon, "Effect of Different Types of Electrodes in Electro-
phonic Hearing," J. Acous. Soc. Am., Vol. 25(2):236-245, March 1953.
71. Franken, Peter A., and The Staff of Bolt Beranek and Newman, Inc., Methods of Space Vehicle Noise Prediction, WADC TR 58-343, Vol. II, September 1960.
72. French, N. R., and Steinberg, J. C., "Factors Governing the Intelligibility of Speech," J. Acous. Soc. Amer., 19:90-119, January 1947.
73. Frey, A. H., "Auditory System Response to Modulated Radio Frequency Energy," Presented at Fourth International Conference on Medical Electronics, July 1961.
74. Frey, A. H., "Auditory System Response to Radio Frequency Energy," Aerospace Medicine, p. 1140-1143, December 1961.
75. Frey, Allan H., "Human Auditory System Response to Modulated Electromagnetic Energy," J. of Applied Physiology, Vol. 17(4), July 1962.

76. Fromm, B., Nysten, C. O. and Zotterman, Y., "Studies in the Mechanism of the Wever and Bray Effect," Acta Oto-Laryngol, Vol. 22, 347-386, 1935.
77. Galambos, R., "Suppression of the Auditory Nerve Activity by Stimulation of Efferent Fibers to the Cochlea," J. Neurophysiology, 19:424-347, 1956.
78. Geldard, F. A., "The Perception of Mechanical Vibration," J. Gen. Psychol., 22:243-308, 1940.
79. Geldard, F. A., "Hearing Through the Skin," Research Revs., October 1954.
80. Geldard, F. A., "Cutaneous Channels of Communication," Sensory Communication, Wiley, 1961.
81. Gersuni, O. V., and Volkhov, A. A., "On the Electrical Excitability of the Auditory Organ on the Effect of Alternating Currents on the Normal Auditory Apparatus," J. of Experimental Psychology, Vol. 19, 370-382, 1936.
82. Gibson, Dale C., Final Report: USNEL Flight Deck Communications System, Part I, Noise Attenuating Radio Communications Helmet and Fixed Station Equipment, NEL Report No. 922, 14 March 1960.
83. Goldberger, Leo, Ph.D., and Hold, Robert R., Ph.D., "Studies on the Effects of Perceptual Alteration," Research Center for Mental Health, New York City, August 1961, ASTIA AD 268 782.
84. Grettenberg, T. L., A Criterion for the Statistical Comparison of Communication System, AD 275 467, February 1962.
85. Haagen, C. Hess, Intelligibility Measurement: Twenty-Four Word Multiple-Choice Tests, AD 351 11, OSRD Report No. 5567, 11 September 1945.
86. Hallpike, C. S. and Rawdon-Smith, A. F., "The Wever and Bray Phenomenon, A Study of the Electrical Response in the Cochlea With Special Reference to its Origin," J. Physiol., 81:395-408, 1934.
87. Hallpike, C. S. and Hartridge, H., "On the Response of the Human Ear to Audio Frequency Electrical Stimulation," Proc. Roy. Soc., London, B123:177-193, 1937.
88. Hanel, R. A., "Thermoelectric Microphone for Modulated Ultrasonic Waves," J. Acous. Soc. Amer., 32:11:1436-1442, November 1960.
89. Harris, Catherine S., Liberman, A. M. and Eimas, T., Auditory Signaling: Absolute Identification and Discrimination of Speech and Non-Speech Sounds, ASTIA AD 261 354, Haskens Laboratories, New York, Electronic Systems Division, Air Force Systems Command, USAF, Bedford, Mass. TR 61-30, July 1961.
90. Harris, J. Donald, "A Search Toward the Primary Auditory Abilities," A Decade of Basic and Applied Science in the Navy Office of Naval Research, p. 244, March 1957.

91. Harris, J. Donald, Ph.D., Steps Toward an International Audiometric Zero, NMRL-Memo Report 62-1, AD 279 675, March 1962.
92. Hennebert, P., "Technique del'Audiometrie Radioe lectrique," Ann. Telecomm. 8:553-559, June 1953.
93. Hochman, D., "Some Recent Developments in Communications Equipments for Missile and Space Programs," Presented at the American Rocket Society Fourteenth Annual Meeting, Washington, D. C., November 1959.
94. Hoffmann, G. E., Final Technical Report for Speech Bandwidth Reduction Equipment, ADC USAF, Scope Incorporated, Falls Church, Virginia, ASTIA AD 271 732, July 1961.
95. Houde, R. A., Speech-Compression-System Study: Final Report, ASTIA AD 275 336, 1 July 1959 to 30 June 1961.
96. Hughes, J. R. and Rosenblith, W. A., "Electrophysiological Evidence for Auditory Sensitization," J. of Acous. Soc. Amer., 29(2):275-280, 1957.
97. Huntington, Dorothy, Ph.D., and Ross, Mark, The Reliability and Equivalency of the CID W-22 Auditory Tests, Publication 61-110, School of Aerospace Medicine, USAF Aerospace Medical Center (AFSC) Brooks AFB, Texas.
98. Jerger, James, Ph.D., Comparative Evaluation of Some Auditory Measures, SAM 62-26, USAF Aerospace Medical Division, Brooks AFB, Texas, April 1962.
99. Jones, R. C., Stevens, S. S. and Lurie, M. H., "Three Mechanisms of Hearing by Electrical Stimulation," J. Acoust. Soc. Amer., 12:281-290, 1940.
100. Kempthorne, Design and Analysis of Experience, Wiley, 1955.
101. Klumpp, R. G. and Webster, J. C., Final Report: USNEL Flight Deck Communications System, Part 5, Message Analysis and Personnel, NEL Report 926, 29 November 1960.
102. Kopra, Lennart L., Ph.D. and Strickland, Lee E., Hearing Threshold Levels of Non-Job-Noise-Exposed Air Force Personnel, No. 61-21, School of Aviation Medicine, USAF Aerospace Medical Center (ATC), Brooks Air Force Base, Texas, February 1961.
103. Kopra, Lennart T. and Strickland, Lee E., Noise Exposure of B-52 and KC-135 Aircraft, Univ. of Texas, School of Aerospace Medicine, USAF Aerospace Medical Center, Brooks AFB, Texas, Publication No. 61-117, December 1961.
104. Kriger, Lawrence V., A Simple Wideband 90° Phase Splitter for Speech or Music, Communication Sciences Lab., Electronic Res. Directorate, AF Cambridge Res. Labs, Office of Aerospace Res., USAF, Bedford, Mass., ASTIA AD 271 757, October 1961.

105. Kryter, K. D., The Validity of the Articulation Index, ESD-TDR 62-2, ASTIA AD 272 547, October 1961.
106. Kryter, K. D., Proposed Methods for the Calculation of the Articulation Index, ESD TDR 62-35, Report No. 906, October 1961.
107. Lane, C. E., "Binaural Beats," Physical Review, 26:401-412, 1925.
108. Lane, H. L., Catania, A. C. and Stevens, S. S., "Voice Level: Autophonic Scale, Perceived Loudness and Effects of Sidetone," J. Acous. Soc. Amer., 33(2), February 1961.
109. Lawrence, M. and Yantis, P. A., "Onset and Growth of Aural Harmonics in the Overloaded Ear," J. Acous. Soc. Amer., 28:852-858, September 1956.
110. Lederer, L. G., Ph.D., M.D., Sunuy, L. A. and Schocken, V., M.D., A Hearing Conservation Program for Commercial Jet Age Aviation, Medical Dept., American Airline, Inc., 1942.
111. Leeb, Joseph, "A Chatter Jammer Circuit," Electronic Equipment Engineering, p.31, November 1962.
112. Lempert, J., Wever, E. G., and Lawrence, M., "The Cochleogram and its Clinical Applications: A Preliminary Report," Arch. Oto. 45:61, 1947.
113. Lempert, J., Meltzer, P. E., Wever, E. G., and Lawrence, M., "The Cochleogram and its Clinical Applications, Concluding Observations," Arch. Otolaryngol, 51:307, 1950.
114. Licklider, J. C. R. and Pollack, Irwin, "Effects of Differentiation, Integration and Infinite Peak Clipping Upon the Intelligibility of Speech," J. Acous. Soc. Amer., 20(1):42-57, January 1948.
115. Licklider, J. C. R., "On Psychophysiological Models," Sensory Communication, Wiley, 1961.
116. Loeb, M. and Riopelle, A. J. w/tech. asst. of Schmidt, E. A., The Influence of Intense Contralateral Stimulation on the Loudness of a Low Frequency Tone, AMRL-Report No. 409, Fort Knox, Ky., 28 September 1959.
117. Loeb, Michel, Ph.D. and Riopelle, A. J., Ph.D., The Influence of Loud Contralateral Stimulation on the Threshold for Lower Frequency Tones, AMRL-Report No. 404, Project No. 6X95-20-001-01, 11 November 1959.
118. Loeb, Michel, Ph.D., Comparison of Attenuation of Three Helmets and a Pair of Muffs by the Threshold Shift Method, AMRL-Report No. 429, Project No. 6X95-25-001-01, July 1960.
119. Loeb, M. and Fletcher, J. L. w/tech. asst. of Schmidt, E. A., The Influence of Different Acoustical Stimuli on the Threshold of the Contralateral Ear, AMRL-Report No. 478, Project No. 6X95-25-001, 16 March 1961.

120. Loeb, M. and Dickson, C., "Factors Influencing the Practice Effect for Auditory Thresholds," J. Acous. Soc. Amer., 33:7, July 1961.
121. Loeb, M. and Fletcher, J. L. w/tech. asst. of Schmidt, E., Friedman, S. and Stern, H., Reliability and Temporal Course of Temporary Threshold Shift and Contralateral Threshold Shift., AMRL-Report No. 533, 19 March 1962.
122. Lowry, K., "Cancellation of the Electrical Cochlear Response With Air Conducted and Bone Conducted Sound." J. Acous. Soc. Amer., 14:156-158, October 1942.
123. Marsh, James T., Worden, F. G. and Hicks, T., "Some Effects of Room Acoustics on Evoked Auditory Potentials," Science, Vol. 137, 27, July 1962.
124. Martin, T. B. and Talavage, J. J., Speech Pattern Recognition by Simulated Neural Networks, ASD-TDR 62-511, ASTIA AD 277 200, 1 July 1962.
125. Mayes, Hilton and Hardesty, In-Flight Noise Measurements for Three Project Mercury Vehicles, NASA TN-D997, January 1962.
126. Miller, G. A. and Licklider, J. C. R., "The Intelligibility of Interrupted Speech," J. Acous. Soc. Amer., 22:167-173, March 1950.
127. Miller, George A., Heise, George A. and Lichten, William, "The Intelligibility of Speech as a Function of the Context of the Test Materials," J. of Experimental Psychology, 41:329-335, May 1951.
128. Misrahy, G. A., Shinabarger, E. W. and Arnold, G. E., "Changes in Cochlear Endolymphatic Oxygen Availability, Action Potential and Microphonics During and Following Asphyxia, Hypoxia, and Exposure to Loud Sounds," J. Acous. Soc. Amer., 30(8):701-704, 1958.
129. Moe, C. R., "An Experimental Study of Subjective Tones Produced Within the Human Ear," J. Acous. Soc. Amer., 13:159-166, October 1942.
130. Moeser, W., "Whiz Kid, Hands Down," Life, 14 September 1962.
131. Molyneux, L., "Noise and Biological Phenomena," Presented at 4th International Conference on Medical Electronics, New York, 1961.
132. Montague, W. E., A Comparison of Five Intelligibility Tests for Voice Communication Systems, NEL Report 977, 27 June 1960.
133. Moser, Henry M., Dreher, John J. and Oyer, Herbert, J., The Relative Intelligibility of Speech Recorded Simultaneously at the Ear and Mouth (Preliminary Report), AFCRC TN 55-50, ASTIA AD 59 343; AD 59-342 (Suppl. 1 and 2), February 1955.
134. Moser, H. M., Dreher, J. J. and Oyer, H. J., The Relative Intelligibility of Speech Recorded Simultaneously at Ear and Mouth (Suppl. Report No. 2), AFCRC TN 55-64, May 1956.

135. Moser, Henry M., Dreher, John J. and Oyer, Herbert J., The Relative Intensity of Sound at Various Anatomical Locations on the Head and Neck During Phonation of Vowel Sounds, AFCRC TN 55-70, June 1956.
136. Moser, Henry M. and Dreher, John J., Operational Tests of Miniature Microphones and Receivers, AFCRC TN 56-57, October 1956.
137. Moser, H. M., Dreher, J. J. and Schartzkopf, L. J., An Ear-Mouth Voice Transducer, AFCRC TN 57-54, July 1957.
138. Moser, H. M., Dreher, J. J., O'Neal, J. J. and Oyer, H. J., Comparison of Mouth, Ear and Contact Microphones, AFCRC TN 56-58, October 1956 (Revised January 1958).
139. McChesney, P. E., TSEC/HY-2 Channel Vocoder, Modified, ASTIA AD 266 389, Report No., Contract No. 2342, First Quarterly Report, Department of Army Project No. 3B31-06-031, August 1961.
140. Neff, W. D., "Functions of the Auditory Cortex," Laryngoscope, 68(3):413-419, 1958.
141. Neff, W. D., Nieder, P. C. and Oesterreich, R. E., "Learned Responses Elicited by Electrical Stimulation of Auditory Pathways," Federation Proceedings, 18(1), 1959.
142. Neff, W. D., "Neural Mechanisms of Auditory Discrimination," Sensory Communications, Wiley, 1961.
143. Nickerson, James F., Miller, Shyne, Montague, Webster, Klumpp, Roy G., A Comparison of Five Articulation Tests, ASTIA 236 374, Electronics Res. Lab., Montana State College, Bozeman, Montana, Air Res. and Develop. Command, USAF, Griffiss AFB, New York, March 1960.
144. Nixon, Charles W., Ph.D. and Waggoner, Cecil E., Capt. USAF, Speech During Weightlessness, MRL-TDR 62-45, May 1962.
145. Perlman, H. B. and Case, T. J., M. D., "Electrical Phenomena of the Cochlea in Man," Archives Otolaryngology, 34:710, 1941.
146. Pestalozza, G., Davis, H., Eldredge, D. H., Covell, W. P. and Rogers, J. B., "Decreased Bio-Electric Potentials in the Ears of Senile Guinea Pigs," The Laryngoscope, 37:1113-1122, 1957.
147. Pickett, J. M. and Pollack, Irwin, "Prediction of Speech Intelligibility at High Noise Levels," J. Acous. Soc. Amer., 30(10):955-963, October 1958.
148. Pickett, J. M., Effects of Transmission Band and Message Context on Speech Intelligibility, ASTIA AD 268 609, NRL Report 4690, Engineering Psychology Branch, Applications Res. Div., October 1961.
149. Pietrasanta, A. C., Stevens, K. N. and the Staff of Bolt Beranek and Newman, Inc., Guide for the Analysis and Solution of Air Base Noise Problems, WADC TR 57-702, Biomedical Lab, Aerospace Med. Lab., Aeronautical Systems Div., AF Systems Command, Wright-Patterson AFB, Ohio, November 1961.

150. Pollack, Irwin and Pickett, J. M., "Masking of Speech by Noise at High Sound Levels," J. Acous. Soc. Amer., 30(2):127-130, February 1958.
151. Pope, L. T., Attention Level and Visual and Auditory Monitoring Performance, AMRL-TDR-62-97.
152. Puharich, Andrija, M.D., "Problems of Instrumentation and Control in Telepathy," Undated paper.
153. Pye, J. D. and Pye, A., Trinidad Expedition, 1961, Technical Report, ASTIA AD 271 650, November 1961.
154. Rachele, Henry, Sound Propagation Through a Windy Atmosphere, ASTIA AD 272 644, February 1962.
155. Reger, Scott N., Effect of Middle Ear Muscle Action on Certain Psycho-physical Measurements, SAM 61-20, Brooks Air Force Base, Texas, November 1960.
156. Rehman, Irving, USNEL Flight Deck Communications System, Part 4: Anatomical and Physiological Criteria Governing the Design of the Noise Attenuating Radio, Communications Helmet, Final Report, NEL Report No. 925, 4 April 1960.
157. Rhine, J. B., "Extra-Sensory Perception and the Engineering World," Presented to Los Angeles Section IRE, 7 December 1961.
158. Rice, E. A., Organ of Cortis Negative Intracellular Polarization, WADD Tech. Report 60-778, January 1962.
159. Rindner, W. and Nelson, R., Raytheon Res. Div., Waltham, Mass., "A New p-n Junction Strain Transducer," 1962 Wescon Convention Record, Part 8, Session on Instrumentation Engineering Management, Chapter 3-4, p. 2124, Los Angeles, California, August 1962.
160. Rindner, W., "On the Resistance of Elastically Deformed Shallow p-n Junctions," J. of Applied Physics, 33:8:2479-2480, August 1962.
161. Rindner, W. and Nelson, R., "Piezo-Junctions: Elements of a New Class of Semiconductor Devices," Proc. of the IRE, Vol. 50, No. 10, October 1962.
162. Rindner, W., "Anisotropic Strain Effect in p-n Junction," Bull. Am. Phys. Soc., Ser. III, Vol. 7, No. 1, p.65-66, 1962.
163. Rindner, W. and Braum, I., "On the Effects of Elastic and Plastic Deformation of p-n Junctions in Semiconductors," Proc. of the Int'l. Conference on the Physics of Semiconductors, Exeter, England. M1377.
164. Ristenblatt, M. P. and Felisky, T., Some Computer Experiments With Predictive Coding of Speech, ASTIA AD 274 984, March 1962.
165. Rivin, A. N., "Acoustical Measurements," Meas. Tech., February 1962, Translated from Izmeritelnaya Tekhnika, No. 9:51-53, September 1961.

166. Robertson, D. W. and Stucky, C. W., Engineering Investigation and Study of Automatic Voice Intelligibility Computation Methods, ASTIA AD 273 898, Engineering Experiment Station of Georgia Inst. of Tech., Atlanta, Georgia, 1 February 1962.
167. Robinson, F. R. and Cleary, J. P., Effects of High Intensity Sound on Circulation of the Inner Ear of the Guinea Pig, ASD TN 61-58, May 1961.
168. Rodieck, R. W., Kiang, N. Y. S. and Gerstein, G. L., Quarterly Progress Report, ASTIA AD 275 765, MIT, Cambridge, Mass., 15 April 1962.
169. Rogers, Edward S., "Experimental Tunnel-Diode Electromechanical Transducer Elements and Their Use in Tunnel-Diode Microphones," J. Acous. Soc. Amer., 34(7):883-893, July 1962.
170. Rosenblith, W. A., Sensory Communication, Wiley, 1961.
171. Rosenblith, W. A., "Electrical Responses from the Auditory Nervous System," Annals. of Otolaryngology, Rhineology and Laryngology, 63:839-860, September 1959.
172. Ruben, R. J., Knickerbocker, G. G., Sekula, J., Nager, G. T. and Bordley, J. E., "Cochlear Microphonics in Man, Preliminary Report," Laryngoscope, 69:655, 1959.
173. Ruben, R. J., Sekula, J., Bordley, J. E., Nager, G. G., Knickerbocker, G. G. and Fisch, U., "Human Cochlea Responses to Sound Stimuli," Annals of Otolaryngology, Rhineology and Laryngology, 69:459, 1960.
174. Ruben, R. I., Bordley, J. E. and Leberman, A. T., "Cochlear Potentials in Man," Laryngoscope, 71:1141, 1961.
175. Rydberg, H., "The Excitation Mechanisms of Receptor Cells and the Form of Energy of Nerve Impulses," Acta Otolaryngology, 52:105-110, August 1960.
176. Schwan, Herman P., "Characteristics of Absorption and Energy Transfer of Microwaves and Ultrasound in Tissues," Medical Physics, Vol. 3, 1960.
177. Scidmore, D. L. and Oelrich, M. G., Development of a Standard Communication Rating System, ASTIA AD 274 545, RADC-TDR 62-70, 6 January 1962.
178. Scott, H. H., "Dynamic Noise Suppressor," Electronics, December 1947.
179. Sheyvekhman, B. Yu., Effect of the Action of an Ultrahigh Frequency Field on the Audio (Aural) Sensitivity During Application of Electrodes in the Zone of Projection of the Aural Zone of the Cortex (Lamella of Temporal Bone), ASTIA AD 281 129, May 2, 1962, (AFSC-FTD-TT 62-491).
180. Sharf, D. J., "Intelligibility of Reiterated Speech," J. Acoust. Soc. Amer., Vol. 31, p.423-427, 1959.

181. Shyne, N. A., Speech-Signal Processing and Applications to Single Sideband, ASTIA AD 276 850, March 1962.
182. Simmons, F. B. and Beatty, D. L., "A Theory of Middle Ear Muscle Function at Moderate Sound Levels," Science, 138:590-591, 2 November 1962.
183. Slivinske, A. J., Robertson, J. G., Ugelow, A., Mello, N. K., Vibratory Communication: Feasibility and Application, ONR TR, Contract NONR 656 (17), ASTIA AD 281 650, October 1959.
184. Snidecor, J. C., Rehman, I. and Washburn, D. D., "Speech Pickup by Contact Microphone at Head and Neck Positions," J. Speech and Hearing Research, 2(3):280, September 1959.
185. Stevens, K. N., "Synthesis of Speech by Electrical Analog Devices," J. Audio Engineering Soc., January 1956.
186. Stevens, K. N., Hecker, M. H. L., and Kryter, K. D., An Evaluation of Speech Compression Systems, RADC-TDR 62-171, ASTIA AD 277 457, 1 March 1962.
187. Stevens, S. S., "On Hearing by Electrical Stimulation," J. Acous. Soc. Amer., 8:191-195, 1937.
188. Stevens, S. S. and Davis, H., Hearing, Wiley, New York, 1938.
189. Stevens, S. S. and Jones, R. C., "The Mechanism of Hearing by Electrical Stimulation," J. Acous. Soc. Amer., 10:261-269, 1939.
190. Stewart, John L., Masking and Speech Pre-Emphasis, MRL-TDR 62-11, March 1962.
191. Stewart, J. L., Two New Speech Communication Systems, MRL-TDR-62-10, March 1962.
192. Stewart, John L., A Quantitative Model for Loudness Discrimination, MRL-TDR 62-12, March 1962.
193. Taggart, Robert, "Underwater Noise Criteria - The Man-Machine Team," Undersea Tech., 2:(6):26-28, November-December 1961.
194. Teas, D. C. and Kiang, N. Y. S., Quarterly Progress Report, ASTIA AD 275 765, 15 April 1962.
195. Thurlow, W. R. and Elfner, L. F., "Localization Effects With Steady Thermal Noise in One Ear and Pulsed Thermal Noise in the Other," Science, 134(3479):617-618, September 1961.
196. Tunturi, A. R., "Localized Responses in Auditory Cortex to Brief Tones in High Level Noise," Amer. J. of Physiology, 195:779-786, 1958.
197. Uttal, W. R., "Cutaneous Sensitivity to Electrical Pulse Stimuli," J. of Comparative & Physiological Psychology, 51:549, 1958.

198. Van Riper, Charles and Irwin, John V., Voice and Articulation, Prentice-Hall, Inc., 1958.
199. Vaughn, E. M., "Resume of Hearing Tests Conducted on Individuals Working in the Vicinity of Magnetostrictive Ultrasonic Generators," J. Acous. Soc. Amer., 29:183, 1957.
200. Victoreen, J. A., Hearing Enhancement, Charles C. Thomas, 1960.
201. Volta, A., "On the Electricity Excited by Mere Contact of Conducting Substances of Different Kinds," Roy. Soc. Phil. Trans., 90:403-431, 1800.
202. Von Bekesy, G., "Gross Localization of the Place of Origin of the Cochlear Microphonics," J. Acous. Soc. Amer., Vol. 24, 409, 1952.
203. Von Bekesy, G., Experiments in Hearing, McGraw-Hill, 1960.
204. Von Bekesy, G., Experimental Models of the Cochlea With and Without Nerve Supply, A Report of Research from the Psycho-Acoustic Laboratory, Harvard University, No. 229, ASTIA AD 268 798.
205. Von Gierke, H. E., "Vibration and Noise Problems Expected in Manned Spacecraft," Noise Control, 5(3):8-16, May 1959.
206. Webster, J. C., Thompson, P. O., Snidecor, J. and Washburn, D. D., "Speech Pickup From Various Anatomical Locations," ASTIA AD 144 524, A Decade of Basic and Applied Science in the Navy, ONR, p. 213-218, March 1957.
207. Webster, J. C. and Klumpp, R. G., USNEL Flight Deck Communications System, Part 2, Noise and Acoustic Aspects, Final Report, NEL Report 923, 29 November 1960.
208. Webster, J. C. and Klumpp, R. G., Evaluation of the PRC-53 (Formerly PRC-34/36) Flight Deck Communications System, NEL Report 1042, 18 April 1961.
209. Webster, J. C., Thompson, P. O. and Wells, T. H., Evaluation of the AN/PRC-44 (XN-1) Flight Deck Communications System, NEL Report 1058, 30 July 1961.
210. Webster, J. C. and Thompson, P. O., "Noise-Proofed" Sound Powered Phones, NEL Report 1073, 25 October 1961.
211. Webster, J. C., Thompson, P. O. and Beitscher, H. R., Intelligibility of Amplified Speech in Helicopter Noise, NEL Report 1080, 7 November 1961.
212. Wever, E. G., Bray, C. W. and Lawrence, M., "The Interference of Tones in the Cochlea," J. Acous. Soc. Amer., 12:268-280, October, 1940.
213. Wever, Ernest Glen, "The Cochlear Potentials and Their Relation to Hearing," Annals of Otology, Rhinology and Laryngology, 68:975, 1950.
214. Withrow, F. B., Jr. and Goldstein, R., "An Electrophysiologic Procedure for Determination of Auditory Threshold in Children," The Laryngoscope, 68(9):1674-1699, 1958.

215. Yaggi, Lawrence A., Jr., Full-Duplex Digital Vocoder, Scientific Report No. 1, AFCRL 62-394, N62-14975, 11 June 1962.
216. Yaffe, Charles D. and Jones, Herbert H. Noise and Hearing: Relationship of Industrial Noise to Hearing Acuity in a Controlled Population, 1961.
217. Zeitlin, Lawrence, R., The Relative Loudness of Pure and Complex Tones, AMRL Report No. 286, 2 January 1957.
218. Zwislocki, J., "Ear Protection-Effecitveness vs. Comfort," Noise Control, 4(6):14-15, 48, November 1958.
219. Zwislocki, J., "Theory of Temporal Auditory Summation," J. Acous. Soc. Amer., 32:1046-1060, August 1960.
220. Description of Test Data, CBS Preliminary #35E Microphone, Contract AF30(635)-18989, Phase II(a) Acoustical Component Part, Wright Air Development Division.
221. "Cordless Audio Receiving Device," Electronics, January 1, 1957.
222. Universal-Helmet Headset, Part Five of Product Improvement of AIC-10 Acoustical Components, Final Report, Contract AF33(600)-33172, October 1958.
223. Frequency Response and Impedance Characteristics of M76 (XA-3/AIC), The Baldwin Company, Cincinnati, Ohio, January 1959.
224. Study and Investigation of Specialized Electro-Acoustic Transducers for Voice Communication in Aircraft, Staff, Western Electro-Acoustic Lab., Inc., Los Angeles, California, Final Report, ASTIA AD 212,459, February 1959.
225. Study and Investigation of Specialized Electro-Acoustic Transducers for Voice Communication in Aircraft, Staff, Western Electro-Acoustic Lab., Inc., Los Angeles, California, Appendices 1 - 6, Final Report, Contract AF33(616)-3710, ASTIA AD 212 210, February 1959.
226. Forehead Microphone Development, Prepared for North American Aviation by Western Electro-Acoustic Lab., Inc., Los Angeles, California TFD 59-545, June 1959.
227. Study and Investigation of Specialized Electro-Acoustic Transducers for Voice Communication In Aircraft, Staff, Western Electro-Acoustic Lab, Inc., Los Angeles, California, Phase II, Final Report, Contract AF33(616)-3710, ASTIA AD 231-531, January 1960.
228. Intercommunication Set, Sound Powered AN/GIC-10(XA-1) Part Seven of Product Improvement of AIC-10 Acoustical Components, Final Report, Contract AF33(600)-33172, February 1960.
229. "New Sound Technique for Voice From Space "Cocktail Party Effect", " Missiles and Rockets, p. 97-104, 18 July 1960.

230. "Voice Recovery for Space Communications," Staff, Electronic Equipment Engineering, September 1960.
231. Bibliography of Research Reports and Publications Issued by the Bio-Acoustics Branch, Aerospace Medical Laboratory, Wright Air Development Division, Air Research and Development Command, USAF, Wright-Patterson AFB, Ohio, December 1960.
232. Hearing Standards, Capitol Records paper on Project 192-536, May 1961.
233. Forehead Microphone, Part Ten of Product Improvement of AIC-10 Acoustical Components, Final Report, Contract AF33(600)-33172, June 1961.
234. Periodic Status Report XXXVIII, Harvard University Psycho-Acoustic Laboratory, Project 142-201, ASTIA AD 268 471, 1 December 1961.
235. Optimum Speech Signal Mapping Techniques - Final Report F428-1, Rome Air Development Center, Air Research & Development Command USAF, Griffiss Air Force Base, New York, RADC-TR-62-3, ASTIA AD 273 443, 10 January 1962.
236. "Digital to Voice Conversion," Staff, Electronic Equipment-Engineering, 10(5):24-26, May 1962.
237. "Cocktail Party Effect," Staff, Electronic Equipment Engineering, p. 23-24, November 1962.

DISTRIBUTION LIST

<u>No. of Copies</u>		<u>No. of Copies</u>	
1	ASD (ASRNCS-1/John S. Flatz) W-P AFB, Ohio	1	AFSC (SCRC) Andrews AFB Washington 25, D.C.
1	ASD (ASAPR/Library) W-P AFB, Ohio	1	Dept. of the Army ATTN: Library Washington 25, D. C.
3	ASD (ASAPT) W-P AFB, Ohio	1	Air University)Major D. D. Ryder) Warfare Systems School Maxwell AFB, Alabama
6	ASD (ASRNCS-2/R. R. Schuster) W-P AFB, Ohio	10	ASTIA (TPIC) Arlington Hall Stn Arlington 12, Va
1	ASD (MRMA/Lt. Col. Guild) W-P AFB, Ohio	1	Bureau of Naval Weapons RMWC 5211 (Mr. L. Bosin) Department of the Navy Washington 25, D. C.
1	ASD (MRMA/Capt. L. O. Hoeft) W-P AFB, Ohio	1	U. S. Navy Electronics Laboratory Code 3250C (A. V. Loveberry) San Diego 52, Calif
1	AFCRL (CRRS/Robert M. Alexander) L G Hanscom Fld Bedford, Mass	1	Commanding Officer U. S. Army Signal Research & Development Laboratories ATTN: SIGFM/GDA Ft. Monmouth, New Jersey
1	RADC (RAUA/Albert Feiner) Griffiss AFB, N. Y.	1	Commanding Officer U. S. Army Signal Research & Development Laboratories ATTN: Technical Document Center Ft. Monmouth, New Jersey
1	RADC (RAUED/David A. Bone) Griffiss AFB, N. Y.	1	Chief of Naval Research Dept. of the Navy Washington 25, D.C.
1	SSD (SSTRG/Capt. John F. Tierman) AF Unit Pose Office Los Angeles 45, Calif	1	Director Naval Research Laboratory Dept. of the Navy ATTN: Library
1	AFSC Technical Liaison Office Room 2305, Munitions Bldg. Washington 25, D. C.		
1	AFSC (STOL/Mr. Frank Braugh) 6331 Hollywood Blvd. Los Angeles 29, Calif		
1	Chief, Technical Library Office of Asst. Sec. of Defense (R&D) Room 3E 1065, The Pentagon Washington 25, D. C.		
1	USAFA U. S. Air Force Academy, Colorado		
1	Air Force Office of Scientific Research Technical Library Washington 25, D. C.		

<u>No. of Copies</u>	<u>Activity</u>
1	Bissett-Berman Corp. ATTN: William B. Snow 2941 Nebraska Avenue Santa Monica, Calif
1	CBS Laboratories ATTN: Mr. Ben Bauer High Ridge Road Stamford, Connecticut
1	Sub-committee on Noise Research Center ATTN: Dr. Grant Fairbanks 327 Alvarado Street Los Angeles 57, Calif
1	University of California Los Angeles ATTN: Prof. John Lyman Bio-technology Laboratory Department of Engineering Los Angeles 24, Calif
1	Ohio State University ATTN: Professors Frederick H. Shillito H. M. Moser Columbus 10, Ohio
1	North American Aviation Corp. ATTN: G. S. Hayes Space & Information Division Dept 695-230 12214 Lakewood Boulevard Downey, Calif

Aeronautical Systems Division, Dir/Avionics Division, Electromagnetic Warfare and Communications Lab, Wright-Patterson AFB, Ohio.
Rpt. No. ASD-TDR-63-157, INVESTIGATION OF DIPLEXING TRANSDUCERS FOR VOICE COMMUNICATIONS. Final report, 1 Feb. 63, 55p. incl illus., tables, and refs.

Unclassified Report

The physiological problems relating to the wearing of communications microphones and headsets by personnel in aerospace vehicles are defined in this report. Methods of providing full duplex voice communication with a single dual-purpose transducer are discussed. Air conduction, bone conduction, electrophonic phenomena, and direct radio frequency stimulation for the purpose of communication are considered in this study.

An ear canal insert diplexer system (dual-purpose transducer) is found through research and direct experiment to yield good intelligibility without interfering with other body functions. A superaudible chopper diplexing method is also selected as a promising technique for utilization of a dual-purpose transducer. The use of the proposed systems in aerospace vehicles for extended periods is found to be entirely feasible.

1. Transducers
2. Diplexers
3. Intelligibility
4. Intercommunication

- I. AFSC Project 4335, Task 433506
- II. Contract Number AF33(657)-7751
- III. Spacelabs, Inc., Van Nuys, Calif.
- IV. Prepared by Alan Dale Bredan under direction of George H. Sullivan

Aeronautical Systems Division, Dir/Avionics Division, Electromagnetic Warfare and Communications Lab, Wright-Patterson AFB, Ohio.
Rpt. No. ASD-TDR-63-157, INVESTIGATION OF DIPLEXING TRANSDUCERS FOR VOICE COMMUNICATIONS. Final report, 1 Feb. 63, 55p. incl illus., tables, and refs.

Unclassified Report

The physiological problems relating to the wearing of communications microphones and headsets by personnel in aerospace vehicles are defined in this report. Methods of providing full duplex voice communication with a single dual-purpose transducer are discussed. Air conduction, bone conduction, electrophonic phenomena, and direct radio frequency stimulation for the purpose of communication are considered in this study.

An ear canal insert diplexer system (dual-purpose transducer) is found through research and direct experiment to yield good intelligibility without interfering with other body functions. A superaudible chopper diplexing method is also selected as a promising technique for utilization of a dual-purpose transducer. The use of the proposed systems in aerospace vehicles for extended periods is found to be entirely feasible.

1. Transducers
2. Diplexers
3. Intelligibility
4. Intercommunication

- I. AFSC Project 4335, Task 433506
- II. Contract Number AF33(657)-7751
- III. Spacelabs, Inc., Van Nuys, Calif.
- IV. Prepared by Alan Dale Bredan under direction of George H. Sullivan