

UNCLASSIFIED

AD NUMBER

AD388285

CLASSIFICATION CHANGES

TO: unclassified

FROM: confidential

LIMITATION CHANGES

TO:

Approved for public release, distribution unlimited

FROM:

DoD Controlling Organization: Department of the Army, Office of the Adjutant General, Washington, DC 20310.

AUTHORITY

13 May 1979 per DoDD 5200.10 document marking; Adjutant General's Office [Army] ltr dtd 29 Apr 1980

THIS PAGE IS UNCLASSIFIED

AD NO. AD388285

DDC FILE COPY



**CONFIDENTIAL**  
DEPARTMENT OF THE ARMY  
OFFICE OF THE ADJUTANT GENERAL  
WASHINGTON, D.C. 20310

*Handwritten initials/signature*

(18) **ACSFOR**

(19)

IN REPLY REFER TO  
AGAM-P (M) (12 Sep 67) FOR **OT-RD-670357**

26 September 1967

SUBJECT: ~~Operational Report~~ - Lessons Learned, Headquarters, 18th Military Police Brigade

TO: SEE DISTRIBUTION

*Operational Report for quarterly period ending 30 Apr 67.  
(11) 13 May 67  
(12) 49P.*

1. Forwarded as inclosure is ~~Operational Report~~ - Lessons Learned, Headquarters, 18th Military Police Brigade, for quarterly period ending 30 April 1967. Information contained in this report should be reviewed and evaluated by USACDC in accordance with paragraph 6f, AR 1-19 and by USCONARC in accordance with paragraph 6c and d, AR 1-19. Evaluations and corrective actions should be reported to ACSFOR OT within 90 days of receipt of covering letter.

2. Information contained in this report is provided to the Commandants of the Service Schools to insure appropriate benefits in the future from lessons learned during current operations, and may be adapted for use in developing training material.

BY ORDER OF THE SECRETARY OF THE ARMY:

*Kenneth G. Wickham*

KENNETH G. WICKHAM  
Major General, USA  
The Adjutant General

1 Incl  
as

DISTRIBUTION:

- Commanding General
  - US Army Combat Developments Command
  - US Continental Army Command
- Commandants
  - US Army Command and General Staff College
  - US Army War College
  - US Army Air Defense School
  - US Army Artillery and Missile School
  - US Army Armor School
  - US Army Military Police School
  - US Army Infantry School

**DDC**  
**RECEIVED**  
**MAR 22 1968**  
**RECEIVED**  
**D**

REGRADED UNCLASSIFIED WHEN  
SEPARATED FROM CLASSIFIED  
INCLOSURES

(Continued on page 2)

*(003650)*

**CONFIDENTIAL**

FOR OT RD  
670357

*B*

# CONFIDENTIAL

2

## DISTRIBUTION (Cont'd)

- US Army Intelligence School
- US Army Medical Field Service School
- US Army Ordnance School
- US Army Quartermaster School
- US Army Transportation School
- US Army Signal School
- US Army Special Warfare School
- US Army Civil Affairs School
- US Army Aviation School

### Copies furnished:

- Director of Research and Engineering
- Office of the Secretary of Defense
  - ATTN: Southeast Asia Forces, Dr. Martin J. Bailey
- Office of the Joint Chiefs of Staff (SASM)
- Office, Chief of Staff, US Army
- Deputy Chiefs of Staff
- Chief of Research and Development
- Assistant Chiefs of Staff
- Chief of Engineers
- The Surgeon General
- The Provost Marshal General
- Commanding General
  - US Army Weapons Command
- Commanding Officer
  - 18th Military Police Brigade
- Joint Action Control Officer
- Security Officer
  - Los Alamos Scientific Laboratory
- Research Analysis Corporation
- National Aeronautics and Space Administration
  - ATTN: Office of Defense Affairs

ADMISSION for	
CFSTI	WHITE SECTION <input type="checkbox"/>
DDC	BUFF SECTION <input type="checkbox"/>
UNANNOUNCED	<input type="checkbox"/>
JUSTIFICATION	
BY	
DISTRIBUTION/AVAILABILITY CODES	
DIST.	AVAIL. and/or SPECIAL
9	

2

# CONFIDENTIAL

# CONFIDENTIAL

3  
DEPARTMENT OF THE ARMY  
HEADQUARTERS, 18TH MILITARY POLICE BRIGADE  
APO SAN FRANCISCO 96491

AVBGI

13 May 1967

SUBJECT: Operational Report for Quarterly Period Ending 30 April 1967,  
RCS CSFOR-65 (U)

TO: Deputy Commanding General  
United States Army, Vietnam  
ATTN: AVHGC-DH  
APO 96307

## SECTION I

### Significant Organization or Unit Activities

1. (U) MISSION. During the period 1 February 1967 through 30 April 1967, the 18th Military Police Brigade provided military police support throughout Vietnam to US Army areas, installation commanders and tactical commanders, and US Agency for International Development (USAID). This support consisted of the enforcement of military laws, orders and regulations; criminal investigations; physical security for installations, ships, harbors and billets; combat support missions of convoy escorts, route security, traffic control and evacuation of Prisoners of War (PW) from combat unit collecting points to Army of the Republic of Vietnam (ARVN) PW camps; refugee control and displacement; and operation of joint population and resources control checkpoints with the National Police (Cank Sat), ARVN Military Police (Quan Canh) and, where appropriate, Free World Forces.

2. (C) ORGANIZATION. a. (C) The major subordinate headquarters of the command are:

- (1) 16th Military Police Group.
- (2) 89th Military Police Group.
- (3) Military Police Group (Criminal Investigation) (Provisional).
- (4) 212th Military Police Company (Sentry Dog).

b. (U) Since the last reporting period, the following organizational changes have been made:

ACSFOR-RD File  
670357

1  
CONFIDENTIAL

DOWNGRADED AT 3 YEAR INTERVALS;  
DECLASSIFIED AFTER 12 YEARS.  
DOD DIR 5200.10

# CONFIDENTIAL

4

AVBGI

13 May 1967

SUBJECT: Operational Report for Quarterly Period Ending 30 April 1967,  
RCS CSFOR-65 (U)

(1) Company D, 52d Infantry was reassigned from the 97th MP Battalion to the 95th MP Battalion on 9 February.

(2) 3d Platoon, 615th MP Co was relieved from attachment to the 92d MP Bn and rejoined its parent unit within the 720th MP Bn on 20 April.

c. (U) The present organization of the 18th MP Bde is shown in Incl 1. The current Brigade station list is at Incl 2.

d. (C) The only unit programmed in for the Brigade is the 981st MP Co (Sentry Dog), currently undergoing training at Ft. Carson, Colorado. It is due in RVN in December 1967.

e. (U) Due to the DA moratorium on submitting non-emergency MTOEs, only the following organizational activities were performed at this headquarters during the reporting period:

(1) NAADS' MTOEs for each Brigade unit were submitted to USARV during 10-13 February 1967. These documents reflected unit authorization of personnel and equipment as of 31 December 1966.

(2) TOE 19-262G, HHD, MP Bde, was reviewed by headquarters and recommended changes, based on experience gained in RVN, were prepared for submission to US Army Combat Developments Command, Military Police Agency (USACDC MPA), Ft. Gordon, Ga.

(3) Subordinate commands were directed to review TOE 19-36G, HHD, MP Bn (Corps, Airborne Corps, or Army) and TOE 19-37G, MP Co, MP Bn (Corps, Airborne Corps, or Army) and to submit recommended changes to this headquarters for review, consolidation and forwarding to USACDC MPA, Ft. Gordon, Ga.

(4) This headquarters received copies of TOE 19-272H, HHD, MP Gp from USACDC MPA for information and informal review. This document will be reviewed by this headquarters and copies furnished the subordinate groups for information and comment.

3. (U) KEY PERSONNEL ASSIGNMENTS AND DEPARTURES. a. LTC Anderson, David J. from Commanding Office, 179th MP Det to CONUS.

b. LTC Dougherty, John E. from CONUS to Commanding Officer, 179th MP Det.

# CONFIDENTIAL

5  
**UNCLASSIFIED**

AVBGI  
SUBJECT: Operational Report for Quarterly Period Ending 30 April 1967,  
RCS CSFOR-65 (U) 13 May 1967

- c. LTC George, Richard E. from CONUS to Commanding Officer, 90th MP Det.
- d. LTC Green, Raymond from Deputy Provost Marshal, 178th MP Det to PACEX.
- e. LTC Hill, John P. from Commanding Officer, 92d MP Bn to CONUS.
- f. LTC Hubbel, Richard O. from Sub Area Provost Marshal, 89th MP Gp to CONUS.
- g. LTC Kerr, Otto Jr. from Executive Officer, 89th MP Gp to CONUS.
- h. LTC Pitchford, Harold from Commanding Officer, 97th MP Bn to MACV.
- i. LTC Riddle, Hugh H. from Commanding Officer, 90th MP Det to CONUS.
- j. LTC Sprinkle, Homer R. from Commanding Officer, 177th MP Det to Commanding Officer, 95th MP Bn.
- k. LTC Talbot, Earnest E. from CONUS to Commanding Officer, 177th MP Det.
- l. LTC Yarbrough, Ben from CONUS to Executive Officer, 89th MP Gp.
- m. LTC Young, Bruce C. from Provost Marshal, 25th Inf Div to Commanding Officer, 92d MP Bn.
- n. MAJ Beachem, Charles from S-2, 18th MP Bde to CONUS.
- o. MAJ Hayes, Everett from Deputy Provost Marshal, 177th MP Det to Sub Area Provost Marshal, 178th MP Det.
- p. MAJ Ingram, Jerry from Sub Area Provost Marshal, 178th MP Bn to CONUS.
- q. MAJ Jones, Robert C. from Chaplain, 720th MP Bn to Chaplain, 89th MP Gp.
- r. MAJ Morris, Robert E. from CONUS to Sub Area Provost Marshal, 179th MP Det.

**UNCLASSIFIED**

# UNCLASSIFIED

AVBGI 13 May 1967  
SUBJECT: Operational Report for Quarterly Period Ending 30 April 1967,  
RCS CSFOR-65 (U)

- s. MAJ Norris, Graham from Commanding Officer, Co C, 54th Inf to S-3, 97th MP Bn.
- t. MAJ Siegle, Eugene E. from Executive Officer, 95th MP Bn, to CONUS.
- u. MAJ Singer, Jerome from Sub Area Provost Marshal, 177th MP Det to CONUS.
- v. MAJ Sockwell, Grady E. from CONUS to Executive Officer, 92d MP Bn.
- w. MAJ Townsend, Robert E. from Sub Area Provost Marshal, 179th Det to Security Officer, 3d Ord.
- x. MAJ Warmath, Julius G. from Commanding Officer, Co C, 52d Inf to 3d Bde, 4th Inf.
- y. CPT Daxe, Arnold, Jr. from CONUS to Asst S-4, 18th MP Bde.
- z. CPT Donovan, Charles F. from CONUS to Asst S-3, 18th MP Bde.
- aa. CPT Gentner, William E. from 1st Inf Div to Asst S-3, 18th MP Bde.
- bb. CPT Goldman, Harold from Commanding Officer, 557th MP Co to S-2, 89th MP Gp.
- cc. CPT Poley, William P. from 90th Repl Bn to Asst S-1, 18th MP Bde.
- dd. CPT Quickel, Jacob from Commanding Officer, 188th MP Co to CONUS.
- ee. CPT Shumway, Walter from Commanding Officer, 218th MP Co to Asst S-3, 16th MP Gp.
- ff. CPT Wolf, Lowell P. from Asst S-1, 18th MP Bde to CONUS.
- gg. CPT Shannon, Douglas from CONUS to S-3, MP Gp (CI) (Prov); from S-3, MP Gp (CI) (Prov) to S-2, 18th MP Bde.

# UNCLASSIFIED

## CONFIDENTIAL

AVBGI

13 May 1967

SUBJECT: Operational Report for Quarterly Period Ending 30 April 1967,  
RCS CSFOR-65 (U)

4. (C) PERSONNEL, MORALE AND DISCIPLINE. a. (U) Awards and Decorations. The 18th MP Brigade is authorized to award the Purple Heart and the USARV Certificate of Achievement. In March the Brigade established its own Certificate of Achievement and has authorized battalion commanders to award the Certificate. Continued command emphasis has resulted in a greater number of deserving individuals receiving awards on a timely basis. During the period four Legions of Merit, three Soldier's Medals, two Bronze Stars with V device, 57 Bronze Stars for Service, one Air Medal, two Army Commendation Medals with V Device, 106 Army Commendation Medals for Merit or Achievement, 12 Purple Hearts, 198 USARV Certificates of Achievement and 57 Brigade Certificates of Achievement were awarded. There were no problem areas in the administration of the program.

b. (U) Reenlistments. On 3 March SFC H. L. Butcher joined the Brigade as Career Counselor. He has established an effective reenlistment program. During the month of April he made at least one visit to every battalion of the Brigade to aid in developing an effective reenlistment program and to counsel individuals desiring information on career opportunities. The program has resulted in a favorable increase in reenlistments over the last quarter, as indicated below:

## (1) Quarter Ending 31 January 1967:

RA 1st Term Reenlistments	6.6 %
RA Career Reenlistments	63.61%
AUS Reenlistments	10.0 %

## (2) Quarter Ending 30 April 1967:

RA 1st Term Reenlistments	11.9%
RA Career Reenlistments	80.0%
AUS Reenlistments	00.0%

c. (U) Civilian Employees, Number and Use. This headquarters employs four direct hire local national personnel who are in clerical positions. In addition, one is utilized as a translator in dealings with other daily hire personnel. Eleven daily hire personnel are utilized by this headquarters for constructing bunkers, parking areas, drainage ditches, sumps, fences, and other projects that require manual labor. These 11 personnel are utilized throughout the Brigade cantonment area which is occupied by this headquarters, a group headquarters, a battalion headquarters, and four companies.

CONFIDENTIAL



# CONFIDENTIAL

8

AVBGI  
SUBJECT: Operational Report for Quarterly Period Ending 30 April 1967,  
RCS CSFOR-65 (U) 13 May 1967

d. (U) Special Services Activities. The R & R program is meeting continued success. With continued command interest the percentage of utilization is increasing. The following R & R allocations were received from USARV with indicated utilization:

<u>MONTH</u>	<u>QUOTA</u>	<u>UTILIZATION PERCENTAGE</u>
February 1967	282	91.8%
March 1967	267	94.1%
April 1967	397	98.4%

e. (C) Strengths.

(1) As of 1 February 1967

	<u>AUTH</u>			<u>ASG</u>		
	OFF	WO	EM	OFF	WO	EM
HHD, 18th MP BDE	16	2	37	25	2	75
18th MP BDE	225	61	4842	229	75	5002

(2) As of 30 April 1967:

	OFF	WO	EM	OFF	WO	EM
	16	2	37	25	4	112
	225	61	4842	210	71	5256

f. (U) Officer Infusion. Arrival in RVN of the Brigade's seven infantry companies during November 1966 caused a serious rotational hump among infantry officers. Upon coordination with USARV, an infusion program was developed and 14 lieutenants, MOS 1542, were reassigned effective 13 April 1967. Four were assigned to the 199th Inf Bde (LT), and ten to the 1st Cav Div (Air Mobile). To date seven replacement officers have been received. Infusion is to be completed not later than 15 May 1967.

g. (U) Enlisted Infusion. Two serious areas of rotational hump existed among enlisted personnel within the Brigade, occurring upon the arrival of the 720th MP Bn in September 1966 and the arrival of seven infantry companies in November 1966.

# CONFIDENTIAL

9  
UNCLASSIFIED

AVBGI

13 May 1967

SUBJECT: Operational Report for Quarterly Period Ending 30 April 1967,  
RCS CSFOR-65 (U)

(1) The Brigade-directed infusion program of 95B personnel with DEROS of September 1967, as implemented by the 89th MP Group, was highly successful in spreading the hump throughout the four battalions of the Group and required no extensive relocation or loss of operational effectiveness. To further reduce the September hump, 39 enlisted men, grades E-3 and E-4, were infused on a man-for-man basis with the 552d MP Company, II FFV.

(2) To reduce the November rotational hump, the following actions have been completed:

(a) A total of 150 enlisted men in MOS 11 B were infused on a man-for-man basis with the 3d Bde, 4th Inf Div. To preclude disruption of operational commitments, the program was spread over a period of 20 days.

(b) Forty EM from the Brigade's seven infantry companies with PMOS in 11 series but having other than an 11B MOS were reported for reassignment to USARV and transferred to infantry divisions on 13 April 1967.

(c) The Brigade has accepted from infantry divisions a total of 136 EM with DEROS subsequent to November 1967. All personnel were either those twice wounded or with physical limitations which make them unfit for full time duty with a combat unit but fully capable of performing duty with a security unit.

(d) Since the Brigade is currently overstrength 106 personnel in MOS 11B as a result of subparagraph 4g(2)(c) above, action is being taken to infuse an additional 100 personnel with DEROS of November 1967 into infantry divisions.

h. (U) Extension of Overseas Tours. The extension program has been highly successful as indicated by the following figures:

(1) Total Extensions.

	<u>OFF</u>	<u>EM</u>
February 1967	1	72
March 1967	1	134
April 1967	4	82

UNCLASSIFIED

UNCLASSIFIED

10

AVBGI

13 May 1967

SUBJECT: Operational Report for Quarterly Period Ending 30 April 1967  
RCS CSFOR-65 (U)

(2) Extension Under PL 89-735 (Six Months).

	<u>OFF</u>	<u>EM</u>
February 1967	1	42
March 1967	0	30
April 1967	2	34

i. (U) Discipline, Law and Order. Discipline throughout the Brigade has been excellent. During the reporting period there were three Special Courts-Martial, 23 Summary Courts-Martial, and 120 Article 15s.

j. (U) Civic Action. The Civic Action Program received command emphasis through commander's visits and letters, staff liaison and daily bulletin notices. More publicity was given the Program through the Brigade's monthly newspaper. Subordinate units were encouraged to emphasize self-help projects requiring high Vietnamese participation. Subordinate battalions with personnel widely dispersed over large geographical areas have difficulty in operating a centralized Civic Action Program and are consequently encouraging those personnel to support units or installations to which they are attached. It is anticipated that the scope and effectiveness of the Brigade's Civic Action activities will continue to increase during the next reporting period.

k. (U) Piaster Expenditure Reduction Program. This headquarters, in an effort to study the effect of the Program, appointed a Piaster Control Project Officer who interviewed 130 Brigade personnel stationed throughout RVN over a two month period. Personnel interviewed were primarily enlisted men, but also included enforcement personnel, provost marshals, unit commanders, staff officers and Finance personnel. The survey, completed in February 1967, revealed that the average interviewee was 22.1 years old and had been in RVN 6.84 months. He retained an average of \$77.44 per month for in-country spending, and spent \$40.44 per month on the local economy. As a result of this survey, a command letter was issued by this headquarters directing subordinate commanders to increase emphasis on savings programs and to improve on post recreational and organized athletic activities. Results of the survey were also forwarded to USARV, ATTN: Comptroller. During the next quarterly period this headquarters will continuously monitor the Program through staff visits and liaison, command letters and daily bulletins.

l. (U) Historical Program. A variety of means are being used to insure that Brigade achievements are properly recorded. In addition to quarterly ORLLs, daily journal and journal files and an organizational history file are maintained. A collection of unit histories and annual

UNCLASSIFIED

UNCLASSIFIED

AVBGI

13 May 1967

SUBJECT: Operational Report for Quarterly Period Ending 30 April 1967,  
RCS CSFOR-65 (U)

supplements prepared by subordinate units has been placed on permanent file at this headquarters. Photographs are being assembled for preparation of a Brigade Scrapbook. Although this headquarters is not authorized a separate Historical Section, BG Hal C. Pattison, Chief of Military History, DA, expressed pleasure with the Brigade's historical program during a recent visit.

m. (U) Information Activities.

(1) Brigade Newspaper. During the past quarter this headquarters published three editions of its official monthly newspaper, THE ROUNDUP. This four page publication, printed in 1,000 copies, is an excellent command information medium, historical document, and morale booster. Recent issues have emphasized the role of the enlisted man and Brigade combat support missions. Courtesy copies of THE ROUNDUP are widely distributed to other military commands and publications, thereby increasing publicity of Brigade activities and achievements.

(2) Public Information.

(a) A total of 115 news releases with 55 different photographs were processed from subordinate commands or prepared by the Brigade Information Office. Releases are being distributed to a wide range of publications, including the Military Police Journal, Army Digest, The Reporter, The Observer, and Pacific Stars and Stripes.

(b) A total of 478 Home Town News Releases on Brigade personnel were dispatched by this headquarters or subordinate units during the reporting period. This program will be strongly emphasized and more closely supervised during the next quarterly period.

(3) Command Information. Command letters and staff visits, newsletters, daily bulletins, and the Brigade newspaper are among media utilized for disseminating command information. 18th MP Bde Reg 360-81 was published on 20 April 1967, and provides mandatory orientation subjects for newly arrived personnel.

5. (U) INTELLEGEANCE AND COUNTERINTELLIGENCE. a. During the reporting period the S-2 Section continued to make daily liaison visits to USARV, periodic liaison visits to II Field Forces Victor (II FFV), and to the S-2 Section, Long Binh Post. The S-2 Officer also attended weekly USARV conferences and presented daily briefings to the Brigade Commander and staff.

UNCLASSIFIED

# CONFIDENTIAL

12

AVBGI

13 May 1967

SUBJECT: Operational Report for Quarterly Period Ending 30 April 1967,  
RCS CSFOR-65 (U)

b. In accordance with USARV Reg 380-5, announced semiannual counterintelligence inspections were conducted during the reporting period at the 89th MP Gp, 16th MP Gp, MP Gp (CI) (Prov), and the 212th MP Co (SD). The inspections covered classified documents control, accountability procedures, personnel security, storage facilities and security procedures. Except for minor administrative errors all units were reported as having no deficiencies or violations.

c. During the quarter the S-2 Section published and disseminated the following documents to provide staff guidance and procedures on matters of an intelligence nature:

(1) Bde Reg 345-15, Subject: Safeguarding Nondefense Information, dated 21 February 1967.

(2) Bde Reg 380-200, Subject: Armed Forces Censorship, dated 14 April 1967.

(3) Bde SOP, Subject: Censorship Program, dated 14 April 1967.

d. There was a total of 100 security actions processed by the S-2 Section during the quarter. These included requests for security clearances, validation of security clearances, US Army Intelligence Repository requests, local files checks, revocations, and suspensions.

e. Intelligence documents processed consisted of spot intelligence reports from lower, equal and higher commands; daily intelligence summaries from II FFV; reviews from USARV G2; periodic intelligence reports from MACV J-2, USARV G2, and II FFV G-2; and daily intelligence reports from the Combined Operations Center, Saigon/Cholon, Gia Dinh Province Security Committee, a Vietnamese intelligence organization.

f. During the quarter one TOP SECRET, 66 SECRET, 529 CONFIDENTIAL, and 31 FOR OFFICIAL USE ONLY documents were processed. Appropriate distribution was made to subordinate units and higher headquarters.

## 6. (C) PLANS, OPERATIONS AND TRAINING. a. (C) Combat Operations.

(1) Operation Junction City. 96 EM and three officers provided military support for the 1st Inf Div and the 25th Inf Div in Tay Ninh Province during the period 22 February through 18 April. Support consisted of route security, convoy escort and security, evacuation of PWs and enforcement of discipline, law and order (DLO) at base camps.

10

# CONFIDENTIAL

# CONFIDENTIAL

13

AVGBI

13 May 1967

SUBJECT: Operational Report for Quarterly Period Ending 30 April 1967,  
RCS CSFOR-65 (U)

(2) Operation Manhattan. 23 EM and one officer provide daily military police support to the 11th Armored Cav Reg (ACR) operating southeast of Dau Tieng and on either side of the Song Saigon River. Support commenced on 23 April and consists of convoy security and enforcement of DLO.

(3) Operation Oregon. 47 EM and three officers provide daily military police support to a USARV Task Force operating in Quang Tin and Quang Ngai Provinces. Support commenced on 17 April and consists of a Provost Marshal section and a MP platoon providing convoy security and escort, route security, headquarters operation center security, evacuation of PWs and enforcement of DLO.

(4) Operation Pershing. 50 EM and one officer provide daily military police support to the 1st Cav Div (Air Mobile) on Highway 1 in the vicinity of Bong Son. Support commenced on 10 February and consists of route security, convoy escort and security, traffic control, traffic accident investigation, and evacuation of PWs.

## b. (C) Combat Support Operations.

(1) Support for 25th Inf Div resupply convoys from Saigon to Tay Ninh City continued from last quarter. One platoon consisting of 26 EM and one officer provides convoy escort and security, traffic control, and traffic accident investigation on a daily basis.

(2) Support for 9th Inf Div resupply convoys from Saigon to Tan An and return commenced on 17 April. Six EM and two Armored  $\frac{1}{4}$  ton vehicles with pedestal mounted M60 machine guns provide convoy escort and security on a daily basis.

(3) The evacuation of PWs captured by US forces from the collecting points of divisions and separated brigades to the Local ARVN PW Camp by Brigade MPs continued from the last reporting period. An ARVN PW Camp was opened in IV CTZ during this reporting period and PWs captured by US Forces in IV CTZ are evacuated to it. Over 250 PWs were evacuated during the reporting period. Planning for evacuation of Naval detainees is discussed in para 6h(1) below.

(4) Operation Duck, a USARV operation supported by elements of the Brigade from 16 December 1966 to 20 February 1967, concerned the arrival of the 9th Inf Div through the aerial ports of Tan Son Nhut and Bien Hoa and the surface ports of Vung Tau and Saigon. Support consisted of convoy escort and security, traffic control, and area security. A copy of the after action report submitted to USARV is at Incl 3.

//

# CONFIDENTIAL

# CONFIDENTIAL

14

AVBGI  
SUBJECT: Operational Report for Quarterly Period Ending 30 April 1967,  
RCS CSFOR-65 (U) 13 May 1967

(5) Traffic control support for 4th Inf Div convoys in II CTZ commenced on 17 April 67. Seven MPs were provided for the road from Tuy Hoa to Song Cau, five MPs from Mang Yang Pass to Pleiku, and six MPs varied with the 4th Inf Div mission.

(6) Military Police support for the 1st Inf Div commenced on 23 March. A platoon consisting of one officer and 37 EM provides traffic control, convoy security and escort, refugee control, and enforcement of DLO at Di An, Lai Dhe, Phu Loi, and Phuoc Vinh on a daily basis.

c. (C) Area Operations.

(1) During the reporting period Brigade military police became active in another aspect of the Revolutionary Development and Economic Warfare Program in Vietnam. On 10 March three joint police resources and population control checkpoints became operational in the metropolitan Saigon area to control and interdict the flow of illegal commodities in and out of Saigon. The checkpoints are manned by US Military Police, ARVN Military Police and Vietnamese National Police. Similar checkpoint operations have been initiated at two locations on National Highway 1 in the II CTZ and planning is underway to establish additional checkpoints in the Saigon area and on National Highway 4 in the III and IV CTZs, south of Saigon.

(2) To assist the Vietnamese in their observation of the Vietnamese New Year, TET, military police checkpoints and patrols to control the movement of US military traffic were established throughout RVN. Checkpoints were located on the approaches to major cities and at the exits of military installations. Personnel and vehicles without official business in the cities were turned back. Checkpoints were operated during duty hours from 1200 hrs 8 February to 1200 hrs 12 February.

(3) VIP security was provided for visits of the following individuals during the periods indicated. Support consisted of traffic control, escort and security and was provided by six MPs and two radio vehicles for each mission.

(a) GEN Creighton W. Abrams, Vice Chief of Staff, United States Army, during period 26 March--2 April.

(b) GEN Dwight E. Beach, CINCUSARPAC, during the period 10-13 April.

12

# CONFIDENTIAL

15

CONFIDENTIAL

AVBGI

13 May 1967

SUBJECT: Operational Report for Quarterly Period Ending 30 April 1967,  
RCS CSFOR-65 (U)

(4) Physical security for the POL barge off-loading site at Cat Lai was provided commencing on 30 March on a daily basis. This brings to four the number of 1st Log Command barge off-loading sites in III CTZ protected by elements of the Brigade.

(5) Daily convoy escort for patients being medically evacuated from hospitals in the Long Binh—Bien Hoa area to the Tan Son Nhut staging area commenced on 3 March. Support consists of three MPs and an armored  $\frac{1}{2}$  ton vehicle.

(6) The route security operation of Highway 1 from Bien Hoa to Xuan Loc was terminated on 6 March. This was a result of the 11th ACR establishing daily armored convoys between Xuan Loc and Bien Hoa. The Brigade is prepared to resume the operation if required.

(7) Two MPs are provided to guard the Pacific Architects and Engineers (PA&E) payroll on a bi-monthly basis. Support commenced on January and each mission lasts two days.

(8) As a result of the 4 February attack on the Long Binh ASD, Company D, 52d Infantry was relocated from Cam Ranh Bay to Long Binh to assist 3d Ord Bn in the physical security of the ASD. To increase the unit's capability to perform its mission, its strength was increased by two officers and 44 EM.

d. (U) Personnel Operational Commitments. A listing of personnel operational commitments by type of support provided and agencies supported as of 30 April is at Incl 4.

e. (U) VIP Visits. During the reporting period, the Brigade headquarters was visited by five general officers. Each was provided a briefing on Brigade missions, operational deployment and commitments, and a tour of the Military police complex at Long Binh. The scope of the briefing and tour was tailored to the length of the itinerary and area(s) of interest of each guest. The briefings were prepared by the Plans and Operations Section and presented in the Brigade Command and Control Center. VIPs briefed were as follows:

(1) BG R. J. Seitz, Chief of Staff, USARV, on 26 February 1967.

(2) BG H. C. Pattison, Chief, Military History, Department of the Army, on 1 May 1967.

CONFIDENTIAL



# CONFIDENTIAL

16

AVBGI

13 May 1967

SUBJECT: Operational Report for Quarterly Period Ending 30 April 1967,  
RCS CSFGR-65 (U)

(3) BG G. H. Young, Deputy Chief of Staff (P & O), USARV, on 12 March 1967.

(4) LTG J. E. Engler, Deputy Commanding General, USARV, on 17 April 1967.

(5) BG E. F. Cole, Deputy Chief of Staff (P & O) USARV, on 19 April 1967.

f. (C) PLANS, SURVEYS, AND DIRECTIVES.

(1) Copies of LOIs prepared by Brigade headquarters and subordinate units were forwarded to USACDC MPA, Ft. Gordon, Ga. USACDC MPA had requested data on MP operations in RVN for use in preparing field manuals and other instructional material.

(2) Feeder information for a CONARC Liaison Team Questionnaire on joint US/GVN Police operations and combat support operations was submitted to PMO, USARV on 16 March 1967. Details were provided on current responsibilities, relationships, procedures and techniques. A copy of the report is included at Incl 5. Information contained in the report would be applicable to Section II, Part I of this ORLL.

(3) OPLAN 71-67, USARV, was forwarded to 89th MP Gp on 28 April 1967 for information and appropriate action. The plan outlines responsibilities and command relationships for the physical security of Saigon in the event of certain classified contingencies.

(4) LOI 2-67 directed 89th MP Gp to provide personnel and equipment for interior security requirements for Long Binh Ammunition Supply Point.

(5) FM 19-25, MP Traffic Control, was reviewed and recommended changes were forwarded to USAMPS, Ft. Gordon, Ga., through USARV PM.

(6) Annex A, OPLAN 60-67, 18th MP Bde was prepared and forwarded to subordinate groups for action. Annex A supplements classified annex to USARV OPLAN 60-67, and outlines support to be rendered in the evacuation of key indigenous personnel.

(7) During the reporting period, the plans and operations section published and disseminated the following regulations:

14

# CONFIDENTIAL

# CONFIDENTIAL

17

AVBGI

13 May 1967

SUBJECT: Operational Report for Quarterly Period Ending 30 April 1967,  
RCS CSFOR-65 (U)

(a) Bde Reg 190-1, Subject: Efficient Professional Police Services, which furnishes information and instructions relative to the performances of military police duties, was published on 24 February 1967.

(b) Bde Reg 220-1, Subject: Inspection of Small, Isolated Units, outlining procedures and command responsibilities for the inspection of small isolated units, especially sentry dog detachments, was published on 27 February 1967.

(c) Bde Reg 335-13, Subject: Operational After Action Reports, providing guidance to subordinate units on the submission of After Action Reports, was published on 8 March 1967.

(d) Bde Reg 525-10, Subject: Pre Mission Checklist, providing a sample checklist to be used by subordinate units in preparing for missions, was published 25 February 1967.

(e) Bde Reg 670-5-1, Subject: Body Armor Vest and Steel Helmet, prescribing policy on wearing of subject equipment during the conduct of range firing exercises, was published 27 February 1967.

(f) Bde Reg 1-66, Subject: Personnel Resources and Commitments, providing a standard format and procedure for units to use in reporting their personnel resources and commitments, was revised and is being reproduced as of this date.

(8) As required by USARPAC Reg 190-13, this headquarters submitted to USARV PMO on 25 March a list of programmed physical security and crime prevention surveys for calendar year 1967. Input information was provided by the four Provost Marshal Detachments. This was the initial report for what will become an annual requirement.

(9) A military police survey for Long Binh Post was conducted by the III CTZ MP on 24 April. This survey was a result of the programmed increase in troop strength of Long Binh Post from 19,000 troops to 42,000 by August 1967 and a final strength of 50,000 to 80,000 by early 1968. The survey discussed the various missions to be performed by MPs and current authorizations of personnel and equipment. It was recommended that the MP support for Long Binh Post consist of a Provost Marshal Section (four officers, 13 EM) and a TOE 10-57F, MP Company (four officers, 151 EM). The study was reviewed by the headquarters staff and returned with recommended changes.

15

# CONFIDENTIAL

# CONFIDENTIAL

18

AVBGI

13 May 1967

SUBJECT: Operational Report for Quarterly Period Ending 30 April 1967,  
RCS CSFOR-65 (U)

(10) A survey was conducted on 16 April to determine military police support requirements for the Tay Ninh Area. The departure of the 196th Inf Bde (LT) with its organic military police elements resulted in insufficient military police personnel to support the approximately 3000 US personnel, 2000 PHILCAG, and other personnel in this area. Based on the survey, a Provost Marshal, a military police platoon (one officer, 40 EM) and an accredited investigator were provided to support the Tay Ninh Base Camp Commander under the control of the III CTZ PM.

g. (C) 212TH MILITARY POLICE COMPANY (SENTRY DOG).

(1) Ten sentry dog utilization surveys were conducted by the 212th MP Co (SD) during the reporting period to determine the feasibility of future sentry dog team employment and to evaluate their effectiveness in the following locations:

- at Dong Tam. (a) Base camp for the 2d Brigade, 9th Infantry Division
- at Tan An. (b) Base camp for the 3d Brigade, 9th Infantry Division
- Qui Nhon. (c) Surveys were conducted for both ASPs located at
- (d) Vung Chau Mountain Signal Site, near Qui Nhon.
- (e) Logistical Supply Area at Camp McDermott, Nha Trang.
- (f) Long Binh Ammunition Supply Depot.
- at An Khe. (g) Sub Area Command Logistical Supply Area and ASP
- (h) Tuy Hoa Ammunition Supply Depot.
- (i) ASD and Logistical Supply Base at Cam Ranh Bay.

(2) A complete unit history of the 212th Military Police Company (SD) was submitted to the Department of the Army. This was the first complete history ever submitted to DA by this unit.

16

# CONFIDENTIAL

19

CONFIDENTIAL

AVBGI

13 May 1967

SUBJECT: Operational Report for Quarterly Period Ending 30 April 1967,  
RCS CSFOR-65 (U)

(3) A request was submitted for the 212th Military Police Company (SD) recommending the unit be awarded the Meritorious Unit Commendation based upon its past service in the Republic of Vietnam.

(4) Arrangements were made with the 3d Region TMA to airlift all sentry dogs, handlers, and dog food by special mission. Previously all dogs and food were shipped by regular cargo methods and delays of up to ten days were often experienced. These delays often caused a loss of man-dog hours and created hardships on the dogs because of food shortages.

(5) A deployment concept plan was submitted to this headquarters by the 212th MP Co (SD) for future planning purposes in the event another sentry dog company was to deploy to Republic of Vietnam. Problem areas and locations to include utilization and control of dog teams were presented and discussed in the plan.

(6) Plans for a new kennel facility were submitted to this headquarters by the 212th MP Co (SD) in anticipation of a future move to Long Binh. The plans included an area large enough to house the Company Headquarters personnel in addition to the staging kennels required for sentry dog housing, sanitation and care.

h. (U) MISCELLANEOUS.

(1) Following intensified US Naval operations in the Delta and along the coast, USARV directed Brigade to secure Naval detainees at Qui Nhon, Tuy Hoa, Nha Trang, Cam Ranh Bay, Vung Tau, Can Tho, Vinh Long and Phan Rang. A brigade operation order is being staffed as of this date.

(2) During the reporting period, the Brigade Headquarters devoted 89 days to normal operations. On-the-job training of Headquarters personnel was conducted concurrently with normal operations.

7. (U) COMMUNICATIONS ACTIVITIES.

a. (U) Conversion of Radios. The Brigade is presently authorized 276 AN/PRC-6 radios, which are to be replaced by the new squad radios, the AN/PRT-4 and AN/PRR-9. Ten of the new squad radios were scheduled for issuance in April; thereafter the radios will be issued to the Brigade in lots of 15 per month until the conversion is completed. The AN/PRT-4 and AN/PRR-9 will provide increased flexibility and freedom of movement to sentry dog handlers of the 212 Military Police Company (Sentry Dog).

CONFIDENTIAL

CONFIDENTIAL

20

AVBGI

13 May 1967

SUBJECT: Operational Report for Quarterly Period Ending 30 April 1967,  
RCS CSFOR-65 (U)

b. (U) Vessel Security. Communication problems were encountered during the past quarter in securing vessels moving from Vung Tau to Saigon and other locations in the Delta. The AN/PRC-25 used by Brigade personnel did not have sufficient range to provide adequate communication from terminal to terminal, particularly for vessels going into the Delta. The problem was resolved by establishing relay stations along the various vessel routes, thereby providing the additional communications required to contact PBRs and terminal stations.

c. (U) Message Traffic. The number of messages passed over the Brigade RTT net for the past quarter exceeded by approximately 25 per cent the previous quarter's total of 533. Composition of the net was increased by adding stations at Cam Ranh Bay (97th MP Bn) and at Vung Tau (569th MP Co). Total traffic handled for the entire year both for messages sent and received, was as follows:

February 1967	188
March 1967	247
April 1967	<u>225</u>
Total	660

8. (C) LOGISTICS AND MAINTENANCE.

a. (C) Operation Oregon. The Brigade was levied for certain critical supply items, particularly signal and transportation items, to support Operation Oregon. A priority message was transmitted to subordinate commands warning them of an impending transfer of equipment. Since the equipment was needed locally, the 89th Group was tasked with this urgent requirement. When the exact needs were known, subordinate units of the 89th Group provided the required items. Of the equipment provided, 95% was laterally transferred and the losing units were directed to immediately requisition new equipment. These requisitions were all submitted on combat essential priorities.

b. (U) Combat Losses. Revised regulations were published by USARV simplifying the procedures for reporting and requisitioning combat losses. The Brigade has had very few items reportable under combat losses, but items falling in this category can be replaced almost immediately. Periodic combat losses are anticipated from those units and detachments stationed or operating in isolated or outlying areas.

c. (U) Imprest Fund. In accordance with USARV Reg 37-6, an Imprest Fund Ordering Officer was appointed for the 18th MP Bde in October

18

CONFIDENTIAL

UNCLASSIFIED

21

AVBGI

13 May 1967

SUBJECT: Operational Report for Quarterly Period Ending 30 April 1967,  
RCS CSPOR-65 (U)

1966. In March 1967, increased command emphasis was placed on reducing piaster expenditures and supporting the balance of payments deficit. In April 1967, an inspection was conducted of the Brigade Imprest Fund and its operation was considered excellent. Due to the small number of transactions, it was determined that in the interest of economy and good management, the Brigade's Fund could be combined with the 15th Support Brigade's Fund. This was accomplished, and on 12 April 1967, the existing Brigade Imprest Fund was terminated.

d. (U) Brigade Patches. Many meetings were held and much correspondence was transmitted during February and March concerning Brigade patches, both subdued and regular. 1st Log Command, through offshore procurement, is supplying all units in Vietnam with subdued insignia to include organizational patches. All units should receive these patches during May 1967. A letter was also received from the Provost Marshal General advising the Brigade to contact the Defense Support Center in Philadelphia and have the priority for patches raised to an O3. The Brigade submitted a letter through the 14th Inventory Control Center requesting the change. This priority will insure that the 30,000 patches are shipped to RVN by air. The shipment of patches is expected in May.

e. (U) Operation Moose. During the month of March, the MP (CI) (Prov) relocated from Saigon to the military police complex in Long Binh. Eleven personnel were involved in the move, which was accomplished with little difficulty. HHD, 18th MP Bde facilitated the movement by erecting several GP Medium tents for housing personnel and administrative offices. Utilities and drainage were completed prior to 1 April and the unit was 100% operational on 3 April 1967.

f. (U) Electric Wires. Upon the relocation of Brigade Headquarters from Saigon to Long Binh Post, the Brigade was informed that external electricity would be available by late spring. With this in mind, it was decided to install a 100KW generator and run electric lines along the ground to the office facilities. It became evident that the placing of the wires on the ground reduced the power output, and could cause a serious safety hazard should the wires become wet and frayed during the monsoon season. Pacific Architects and Engineers (PA&E) in Saigon was contacted and an emergency work order was placed with the Engineers for immediate action in moving the power lines off the ground. This was accomplished within two weeks after submission and the work was completed by 14 April. PA&E placed poles in the ground and strung the wire overhead. It was subsequently revealed that the generators would remain the chief power source for a longer period than earlier indicated.

UNCLASSIFIED

# CONFIDENTIAL

22

AVBGI

13 May 1967

SUBJECT: Operational Report for Quarterly Period Ending 30 April 1967,  
RCS CSFOR-65 (U)

g. (C) M16A1 Rifles. All MP units in Vietnam will exchange the M-14 for the M-16 rifle within 60 days from 1 May on a priority basis. There is a present total of 1650 M-16s in use in the Brigade, and a total of 3184 M-14s must be exchanged in the near future. The MP battalions have a priority one, followed by separate MP companies which will be given a priority along with other combat service support units. The weapons will be issued on a one for one exchange basis. The M-7 Bayonet, with scabbard M8A1, must be requisitioned after receipt of the rifle.

h. (U) PRC-25 Radios. The 560th MP Co in Vung Tau, which supplies guards for vessels and barges on the Saigon River, recently submitted an emergency requisition for 12 PRC-25 radios. This requisition became necessary due to an increase in the number of ships supported. USARV released six radios to the 560th on a 60 day interim approval basis. The radios will remain the property of the 560th pending acceptance of the MTOE which must be submitted as soon as possible after the interim approval. The additional six radios will be issued as soon as they become available.

i. (U) Reports of Survey. The Brigade S-4 Office has staff responsibility for all Reports of Survey and Quarterly Reports of Operational Loss. During the period from 12 November 1966 to 30 April 1967, 63 Reports of Survey were processed, of which 31 are still pending action. Of the 32 reports fully processed, two have held individuals pecuniarily liable. Weapons were involved in both instances.

j. (U) Brigade Headquarters. Floor plans calling for 6,729 square feet of space for the Brigade permanent Headquarters building at Long Binh Post were approved by the Engineer Command. The building will be preconstructed with individual office space for the Commanding Officer, Deputy Commanding Officer, and principal staff officers. Expected occupancy date is October 1967, although contractors may still be working on minor construction at that time.

# CONFIDENTIAL

# CONFIDENTIAL

23

AVBGI

17 May 1967

SUBJECT: Operational Report for Quarterly Period Ending 30 April 1967,

## SECTION II. PART I

### Lessons Learned

1. (U) PERSONNEL. None.
2. (C) OPERATIONS.

### Prisoners of War

Item: Inter-Corps Transfer of Prisoners of War.

Discussion: Overcrowding in some ARVN PW Camps and the wide differences in area capture rates have made it necessary to move PWs from one Corps Area Camp to a different Corps Area and PW Camp. The coordination for these moves is generally effected through Field Force-MACV channels, since those agencies deal directly with ARVN counterparts. The military police escorting such movements frequently come from Brigade resources, operate within USARV channels, and rely on USARV agencies for support. There have been several occasions when Brigade police elements were not notified of impending inter-corps PW movements. This resulted in lack of organized reception at destination or failure to provide transportation or other logistical support from the destination landing site to the ARVN PW Camp.

Observation: In those inter-corps movements of PW which will require support facilities, equipment or personnel from USARV military police units, USARV PM should be provided with complete operational information necessary to coordinate the activities of their supporting military police resources.

### Joint Police Resources and Population Control Checkpoints

Item: Security of Joint Police Resources and Population Control Checkpoints.

Discussion: The three joint checkpoints in the Saigon area operate daily at stationary sites. For these reasons they are particularly subject to terrorist attack. The need for security was underscored by the attack on a National Police ARVN MP checkpoint in the Saigon area on 4 April 1967. The well coordinated attack took place at 2205 hours by an estimated 250 man Viet Cong force employing explosive demolitions, recoilless rifles and automatic weapons. The checkpoint was briefly overrun, heavy casualties were inflicted on the defenders, and a quantity of arms and ammunition was taken prior to the enemy's withdrawal. This was the second attack on the checkpoint in the past year.

# CONFIDENTIAL



# CONFIDENTIAL

24

AVBOI

13 May 1967

SUBJECT: Operational Report for Quarterly Period Ending 30 April 1967,  
RCS CSFOR-65 (U)

Observation: The vulnerability of static checkpoints can be reduced by careful planning which includes, as a minimum, consideration of the following: locations which are suitable for operations, yet defensible; the construction of defensive positions; lighting for both night operations and security; reliable communications (Vietnamese and US); and manpower requirements. As requirements will vary with each checkpoint, no standard formula can be applied to these basic areas. However, experience clearly indicates that to be effective, reaction forces must be capable of deploying to any given checkpoint within eight to ten minutes after being called.

## Use of Armored 1/2 Ton Vehicle

Item: Experience Factors in Use of Armored 1/2 Ton Vehicles.

Discussion: The Brigade has now operated various configurations of armor protected 1/2 ton vehicles for more than one year. While the armor protection has proved a life saver in many instances, the wear and tear on vehicles is being felt. Brakes, clutches, suspension systems, wheel bearings, and tires suffer unusually short operational reliability.

Observation: The need continues to replace fabricated armor equipped 1/2 ton vehicles with a type, orthodox armored car. Until sufficient numbers of armored cars are made available to meet operational requirements, it can be anticipated that maintenance "down time" will increase among the armored 1/2 ton vehicles. Three Cadillac-Gage V-100 armored cars are scheduled for Brigade assignment in May, and three more are scheduled for June.

Also Note CONARC Liaison Form Questionnaire at Incl 5

### 3. (U) TRAINING AND ORGANIZATION.

#### Commander's Conference

Item: Brigade Bi-Monthly Commander's Conference.

Discussion: The second Brigade Bi-Monthly Commander's Conference was held on 24 February 1967 at Headquarters, 16th MP Gp, Nha Trang, RVN. In attendance were the three group commanders and commanders or representatives of the seven MP battalions and the four Area Provost Marshal Detachments. Representing this Headquarters were the Brigade Commander, Deputy Brigade Commander, S-1, S-3, S-4, Signal and Personnel Officers.

# CONFIDENTIAL

25

CONFIDENTIAL

AVBGI

13 May 1967

SUBJECT: Operational Report for Quarterly Period Ending 30 April 1967,  
RCS C-70R-65 (U)

The agenda of the Conference was designed to permit informal discussion and a mutual exchange of ideas, in seminar fashion, on a broad range of topics applicable to current and future military police operations. A total of five hours and 45 minutes were given over to discussion in six broad areas: Port and Vessel Security; Convoy Escort, Route Security and Road Reconnaissance; Joint Police Operations; Static Security Operations; Provost Marshal Operations; and the "97 Series" System For Operational Planning (a recommended administrative concept for mission planning). Each topic was briefly introduced by a predesignated conferee, followed by a discussion in round-table fashion, with contributions from those in attendance.

Observation: The informal seminar format for the Commander's Conference provides military police commanders and provost marshals, operating throughout the country, an excellent opportunity to "sound-out" local problems and solutions related to common missions.

4. (U) INTELLIGENCE: None.
5. (U) LOGISTICS AND MAINTENANCE: None.
6. (U) OTHER:

Military History Detachment

Item: Need for a Brigade Military History Detachment.

Discussion: The present strength of this command makes it the fourth largest separate brigade in RVN, yet it is one of the few that does not have an historical section. The Brigade's activities range widely throughout RVN and its subordinate units are assuming and accomplishing missions previously unknown to the Military Police Corps. Historical records are presently being maintained as a secondary duty of the Brigade Information Section, resulting in reduced efficiency in both the historical and information programs.

Observation: A military history detachment should be deployed and attached to this headquarters pursuant to para 3d(1), USARV Reg 870-1.

CONFIDENTIAL

UNCLASSIFIED

26

AVBGI  
SUBJECT: Operational Report for Quarterly Period Ending 30 April 1967,  
RCS CSFOR-65 (U)

13 May 1967

SECTION II. PART II

Recommendations

1. (U) PERSONNEL: None.
2. (U) OPERATIONS: On those inter-corps movements of PW which will require support facilities, equipment or personnel from USARV military police units, USARV PM should be provided with complete operational information necessary to coordinate the activities of their supporting military police resources.
3. (U) TRAINING AND ORGANIZATION: None.
4. (U) INTELLIGENCE: None.
5. (U) LOGISTICS: None.
6. (U) OTHER: A military history detachment should be deployed and attached to this headquarters pursuant to para 3d(1), USARV Reg 870-1.

5 Incls  
as

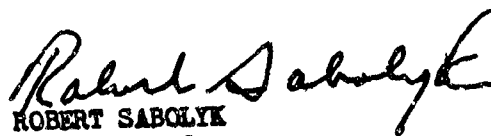
  
ROBERT SABOLYK  
Colonel, MPC  
Deputy Commander

24

UNCLASSIFIED

CONFIDENTIAL

27

AVHGC-DST (13 May 67) 1st Ind  
SUBJECT: Operational Report-Lessons Learned for the Period Ending  
30 April 1967 (RCS CSFOR-65) (U)

HEADQUARTERS, UNITED STATES ARMY VIETNAM, APO San Francisco 96307 7 JUN 1967

→ TO: Commander in Chief, United States Army, Pacific, ATTN: GPOP-OT,  
APO 96558

Assistant Chief of Staff for Force Development, Department of the  
Army, Washington, D. C. 20310

1. (U) This headquarters has reviewed the Operational Report-  
Lessons Learned for the period ending 30 April 1967 from Headquarters,  
18th Military Police Brigade.

2. (C) Pertinent comments follow:

a. Reference item concerning inter-corps transfer of prisoners  
of war, page 21, and paragraph 2, page 24: The problem relative to the  
inter-corps transfer of prisoners of war was brought about because the  
Field Forces, Vietnam coordinated these moves through US advisory chan-  
nels directly with MACV. Through coordination with the Field Forces,  
Vietnam and MACV, this procedure has been changed so that future inter-  
corps movements will be coordinated with USARV by the Field Forces,  
Vietnam.

b. Reference item concerning the need for a brigade military  
history detachment, page 23: As a result of strength limitation imposed  
by OSD Program 4, a military history detachment programmed for deploy-  
ment to support the 18th Military Police Brigade, as well as other de-  
tachments programmed to support other units with even higher priorities,  
was deleted from lists of units to be deployed. Available assets are  
insufficient for full-time support of the 196th Infantry Brigade, three  
nondivisional support commands and the 18th Military Police Brigade, all  
of which need full-time support to insure adequate documentation of their  
activities. It is planned that if additional detachments become avail-  
able for support of units now in RVN, the fourth detachment to arrive  
will be placed in support of the 18th Military Police Brigade. Limited  
historical support has been provided to the 18th Military Police Brigade  
in the form of assistance visits by personnel of the USARV historical  
office, and technical advice is available on call.

FOR THE COMMANDER:

  
E. L. KENNEDY  
CPT, AGC  
Asst Adjutant General

5 Incl  
nc

CONFIDENTIAL

28

GPOP-DT(13 May 67) 2d Ind (U)  
SUBJECT: Operational Report-Lessons Learned for the Period Ending  
30 April 1967 (RCS CSFOR-65), HQ 18th MP Bde

HQ, US ARMY, PACIFIC, APO San Francisco 96558 27 JUL 1967

TO: Assistant Chief of Staff for Force Development, Department of the  
Army, Washington, D. C. 20310

This headquarters concurs in the basic report as indorsed.

FOR THE COMMANDER IN CHIEF:

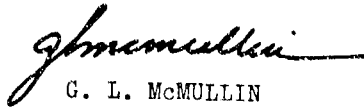

G. L. McMULLIN  
MAJ, AGC  
Asst AG

5 Incl  
nc

CONFIDENTIAL

CONFIDENTIAL

29

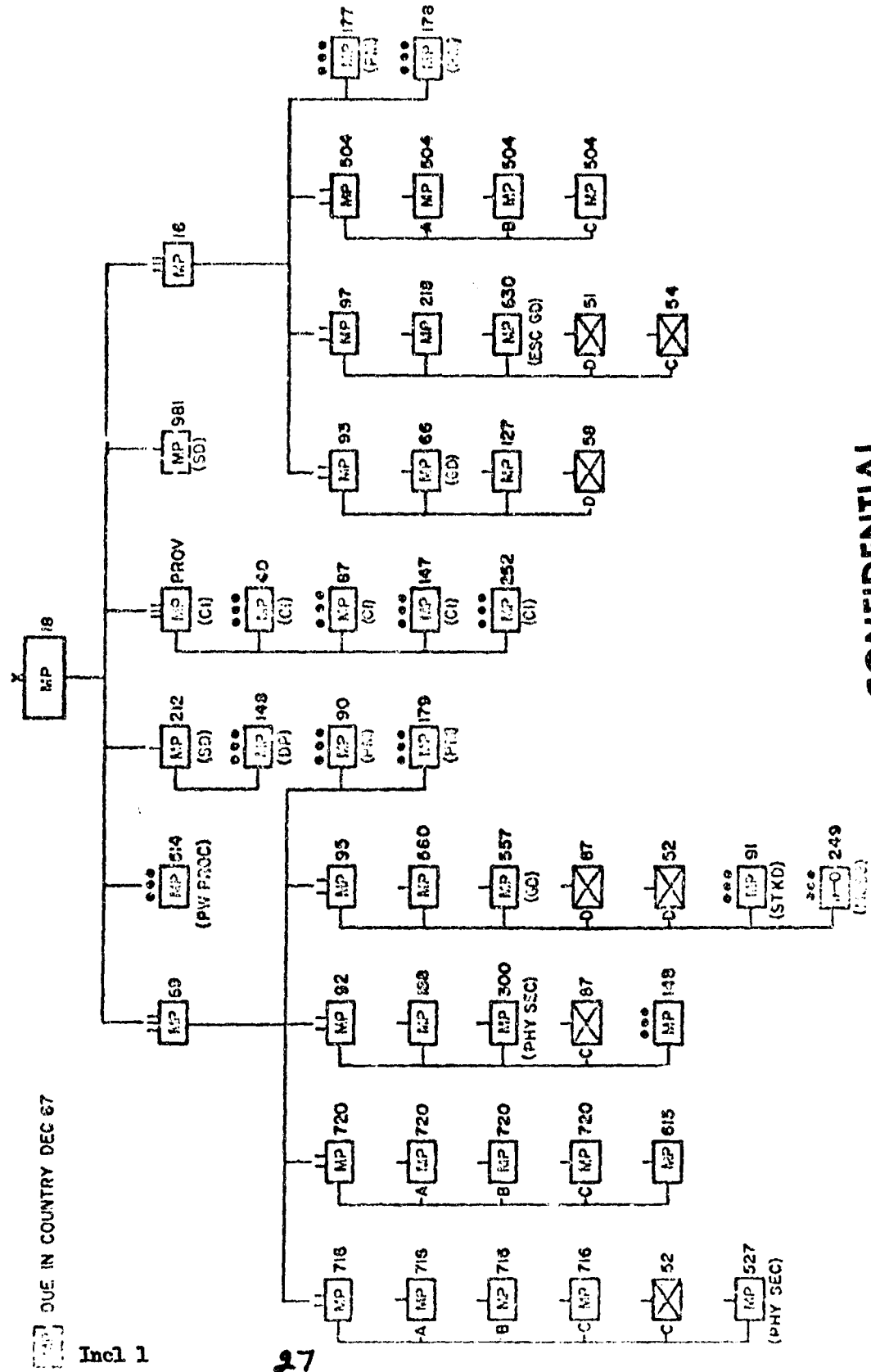

MP 18 DUE IN COUNTRY DEC 67

Incl 1

27

CONFIDENTIAL

31

FOR OFFICIAL USE ONLY

18th MP Bde Cir 210-3

HEADQUARTERS  
18TH MILITARY POLICE BRIGADE  
APO 96491

\*CIRCULAR  
NUMBER 210-3

19 April 1967

(Expires 18 April 1968)

INSTALLATIONS

Station List

1. PURPOSE: To furnish information for units assigned to the 18th Military Police Brigade, to include next higher headquarters, geographical location, and APO number used as a mailing address.
2. Changes, deletions, and additions will be reported to this headquarters, ATTN: AVEGC.
3. This circular will be amended periodically as required.

(AVEGC)

FOR THE COMMANDER:

OFFICIAL:

ROBERT J. KRIWANEK  
Colonel, MPC  
Chief of Staff

  
W. P. POLEY  
Captain, AGC  
Asst Adjutant

Protective markings may be removed from basic circular when separated from inclosure. Protective markings may not be removed from attached inclosure.

1 Incl  
Station List

DISTRIBUTION:

A Plus  
2 Provost Marshal General, Washington, DC 20315  
2 CINCUSARPAC, ATTN: GPPE-PM, APO 96558  
2 CG, MACV, ATTN: J15, APO 96243  
2 CG, USARV, ATTN: AVHPM  
2 CG, USARV, ATTN: AVHAG-M  
2 CG, II FFV, APO 96266

\*This circular supersedes 18th MP Bde Cir 210-3, dated 2 Mar 67.

FOR OFFICIAL USE ONLY

# FOR OFFICIAL USE ONLY

33

<u>ORGANIZATION</u>	<u>NEXT HIGHER HQ</u>	<u>LOCATION</u>	<u>AFO</u>
16th MP Gp, HHD	16th MP Gp	Nha Trang	96240
18th MP Bde, HHD	18th MP Bde	Long Binh	96491
40th MP Det (CI)	MP Gp (CI)(Prov)	Nha Trang	96240
40th MP Det (CI), Field Office	40th MP Det (CI)	An Khe	96490
40th MP Det (CI), Field Office	40th MP Det (CI)	Cam Ranh Bay	96312
40th MP Det (CI), Field Office	40th MP Det (CI)	Da Nang	96337
40th MP Det (CI), Field Office	40th MP Det (CI)	Phan Rang	96347
40th MP Det (CI), Field Office	40th MP Det (CI)	Pleiku	96295
40th MP Det (CI), Field Office	40th MP Det (CI)	Qui Nhon	96238
40th MP Det (CI), Field Office	40th MP Det (CI)	Tuy Hoa	96316
66th MP Co	93rd MP Bn	Qui Nhon	96238
87th MP Det (CI)	MP Gp (CI)(Prov)	Long Binh	96491
87th MP Det (CI), Field Office	87th MP Det (CI)	Tan Son Nhut	96243
87th MP Det (CI), Field Office	87th MP Det (CI)	Xuan Loc	96257
87th MP Det (CI), Field Office	87th MP Det (CI)	Bien Hoa	96227
89th MP Gp, HHD	89th MP Gp	Long Binh	96491
90th MP Det (PM)	89th MP Gp	Saigon	96243
91st MP Det, (Conf)	95th MP Bn	Long Binh	96491
92nd MP Bn, Hq	89th MP Gp	Tan Son Nhut	96307
93rd MP Bn, Hq	16th MP Gp	Phu Thanh	96238
95th MP Bn, Hq	89th MP Gp	Long Binh	96491
97th MP Bn, Hq	16th MP Gp	Cam Ranh Bay	96312
127th MP Co	93rd MP Bn	Qui Nhon	96238
147th MP Det (CI)	MP Gp (CI)(Prov)	Saigon	96243
148th MP Det (Dismt Pt1)	212th MP Co (SD)	Tan Son Nhut	96307
148th MP Plt	92nd MP Bn	Tan Son Nhut	96307
		(TDY Op OREGON)	
177th MP Det (PM)	16th MP Gp	Qui Nhon	96238
178th MP Det (PM), Hq	16th MP Gp	Cam Ranh Bay	96312
178th MP Det (PM)	178th MP Det, Hq	Nha Trang	96240
178th MP Det (PM)	178th MP Det, Hq	Tuy Hoa	96316
179th MP Det (PM)	89th MP Gp	Bien Hoa	96250
188th MP Co	92nd MP Bn	Tan Son Nhut	96307
188th MP Co, 1 Sqd	188th MP Co	Cat Lai	96307
188th MP Co, 1 Sqd	188th MP Co	Nha Be	96307
212th MP Co (SD), Hq	18th MP Bde	Tan Son Nhut	96307
212th MP Co (SD), Det A	212th MP Co (SD)	Pleiku	96295
212th MP Co (SD), Det B	212th MP Co (SD)	Qui Nhon	96238
212th MP Co (SD), Det C	212th MP Co (SD)	Ban Me Thout	96297
212th MP Co (SD), Det F	212th MP Co (SD)	Vung Tau	96291
212th MP Co (SD), Det J	212th MP Co (SD)	Da Lat	96314
212th MP Co (SD), Det L	212th MP Co (SD)	Soc Trang	96296
212th MP Co (SD), Det M	212th MP Co (SD)	Vinh Long	96357
212th MP Co (SD), Det O	212th MP Co (SD)	An Khe	96490
212th MP Co (SD), Det P	212th MP Co (SD)	Long Binh	96491
212th MP Co (SD), Det R	212th MP Co (SD)	Nha Trang	96240
212th MP Co (SD), Det T	212th MP Co (SD)	Phan Rang	96347

## FOR OFFICIAL USE ONLY



# FOR OFFICIAL USE ONLY

34

218th MP Co	97th MP Bn	Cam Ranh Bay	96312
218th MP Co, 3 Sqds	218th MP Co	Nha Trang	96240
218th MP Co, 2 Sqds	218th MP Co	Phan Rang	96347
218th MP Co, 1 Sqd	218th MP Co	Da Lat	96314
218th MP Co, 1 Sqd	218th MP Co	Ban Me Thout	96297
249th QM Det (Mess)	95th MP Bn	Long Binh	96491
252nd MP Det (CI)	MP Gp (CI)(Prov)	Vung Tau	96291
252nd MP Det (CI), Field Office	252nd MP Det (CI)	Can Tho	96215
300th MP Co	92nd MP Bn	Tan Son Nhut	96307
504th MP Bn, Hq	16th MP Gp	Phu Thanh	96238
504th MP Bn, Co A	504th MP Bn	Nha Trang	96240
504th MP Bn, Co A, 1 Plt	504th MP Bn, Co A	Tuy Hoa	96316
504th MP Bn, Co B	504th MP Bn	Pleiku	96295
504th MP Bn, Co B, 1 Sqd	504th MP Bn, Co B	Kontum	96499
504th MP Bn, Co C	504th MP Bn	Phu Thanh	96238
504th MP Bn, Co C, 1 Plt	504th MP Bn, Co C	An Khe	96490
504th MP Bn, Co C, 1 Plt	504th MP Bn, Co C	Bong Son	96238
514th MP Plt (FW Proc)	18th MP Bde	Long Binh	96491
527th MP Co	716th MP Bn	Saigon	96243
557th MF Co (Gd)	95th MP Bn	Long Binh	96491
560th MP Co	95th MP Bn	Vung Tau	96291
560th MP Co, 1 Plt	560th MP Co	Can Tho	96215
560th MP Co, 1 Sqd	560th MP Co	Vinh Long	96357
560th MP Co, 1 Sqd	560th MP Co	Soc Trang	96296
615th MP Co	720th MP Bn	Long Binh	96491
630th MP Co	97th MP Bn	Cam Ranh Bay	96312
716th MP Bn, Hq	89th MP Gp	Saigon	96243
716th MP Bn, Co A	716th MP Bn	Saigon	96243
716th MP Bn, Co B	716th MP Bn	Saigon	96243
716th MP Bn, Co C	716th MP Bn	Saigon	96243
720th MP Bn, Hq	89th MP Gp	Long Binh	96491
720th MP Bn, Co A	720th MP Bn	Long Binh	96491
720th MP Bn, Co B	720th MP Bn	Long Binh	96491
720th MP Bn, Co B, Det	720th MP Bn, Co B	Xuan Loc	96257
720th MP Bn, Co C	720th MP Bn	Long Binh	96491
Co D, 51st Inf	97th MP Bn	Cam Ranh Bay	96312
Co D, 51st Inf (1 Plt)	Co D, 51st Inf	Nha Trang	96240
Co C, 52nd Inf	716th MP Bn	Saigon	96243
Co D, 52nd Inf	95th MP Bn	Long Binh	96491
Co C, 54th Inf, Hq & 1 Plt	97th MP Bn	Tuy Hoa	96316
Co C, 54th Inf, 2 Plt	Co C, 54th Inf	Cam Ranh Bay	96312
Co D, 58th Inf	93rd MP Bn	Phu Thanh	96238
Co C, 87th Inf	92nd MP Bn	Tan Son Nhut	96307
Co D, 87th Inf	95th MP Bn	Long Binh	96491
MP Gp (CI)(Prov), HHD	18th MP Bde	Long Binh	96491

# FOR OFFICIAL USE ONLY

FOR OFFICIAL USE ONLY

AVBGC

35  
SUBJECT: After Action Report, USARV OPLAN 65-67 (Operation DUCK)(U)

TO: Commanding General  
United States Army Vietnam  
ATTN: AVHGC-PO  
APO 96307

1. (U) References: USARV OPLAN 65-67 (Operation DUCK)(U) DTG 171200H Oct 66.

2. (FOUO) Per para 3d, Annex A, reference 1, the following after action report is submitted:

a. This headquarters was tasked with establishing traffic control points and providing security for movement of convoys of the 9th Div and associate units through Saigon/Vung Tau to staging/holding areas and then to the unit's base camp.

b. Units employed. The 179th MP Det (PM) was assigned the mission of controlling and coordinating the overall operation. The 720th MP Bn provided escorts for convoys from Vung Tau and Saigon Port to Bear Cat. The 560th MP Co under the supervision of the PM, Vung Tau established TCPs in the city of Vung Tau and along route 15 to Ba Ria. The USAHAC PMO provided escorts for convoys from Saigon Port to the Newport Bridge.

c. Escort of personnel from Vung Tau.

(1) The 720th MP Bn, in coordination with PM, 1st Inf Div, provided two MP armored jeeps and six MPs to assist in escorting personnel convoys between Vung Tau and Bear Cat. Convoys were run during three periods, 19-23 Dec 66, 2-5 Jan 67, and 30 Jan-3 Feb 67, a total of 1926 vehicles were escorted. No incidents or problems occurred on any convoys.

(2) The 560th MP Co, 95th MP Bn, under the control of PM, Vung Tau, provided 10 MPs to establish seven TCPs in the city of Vung Tau, along Highway 15 to Ba Ria and in Ba Ria. Two Vietnamese military policemen (QC) assisted at key locations on Highway 15. TCPs were located at:

FOR OFFICIAL USE ONLY

AVBGC

SUBJECT: After Action Report, USARV OPLAN 65-67 (Operation DUCK)(U)

36

- (a) The entrance/exit of the port.
- (b) The entrance/exit of the convoy assembly area (SP)

in Vung Tau.

- (c) Four one way bridges on Highway 15 to Baria.
- (d) A key intersection in Baria.

No problem areas were encountered by the TCPs during the operation.

d. Escort of equipment from Saigon Port.

(1) The 720th MP Bn provided two MP armored jeeps and six MPs to escort equipment convoys from Saigon Port to a staging area on Long Binh and from the staging area to the base camp. Coordination/liaison was maintained with the convoy control center at Saigon Port. Convoys were run during the period 16 - 20 Feb 67 based on the arrival of cargo ships. A total of 1966 vehicles were escorted.

(2) The major problem encountered was the fluctuation in the scheduled arrival of ships. This and variations in ship unloading time prevented movement of convoys to be scheduled with any certainty. Telephonic communication between Control Centers at Saigon Port and base camp and the 720th MP Bn made coordination difficult and time consuming. A solution to these problems would be more accurate ship arrival schedules and alternate means of communication between Control Centers and action agencies, such as radio.

(3) Another problem resulted from a change in procedure in convoys movement from Saigon Port. Initially, it was planned to infiltrate vehicles from Saigon Port to Newport. This would have precluded staging convoys in the limited area available at Saigon Port and arranging US and RVN MP escorts. However, just prior to the arrival of the first equipment ship, III TMA informed the MP Traffic Control Officer that vehicles moving from Saigon Port were required to move in convoy. This required a change in plans and the requesting of support from the USAHAC PMD. This support was provided but QC support was not dependable and many convoys moved without QC escort.

e. Recommendation. Aircraft should be provided controlling headquarters to increase convoy control and provide road reconnaissance.

FOR THE COMMANDER:

Incl 3

/s/Lowell P. Wolf  
/t/LOWELL P. WOLF  
CPT , AGC  
ASSISTANT ADJUTANT

31

FOR OFFICIAL USE ONLY

# CONFIDENTIAL

## 18TH MP BDE OPERATIONAL COMMITMENTS

37

USARV		
DL & O	524	
STOCKADE	141	
PHY SECURITY	265	
HQ SECURITY	30	
SENTRY DOG	54	
GRIM INVES	(45) 23	
TFC	95	
SUB TOTAL		1177
1ST LOG CMD		
PORT SECURITY	463	
VESSEL SECURITY	104	
DEPOT SECURITY	347	
PHY SECURITY (OTHERS)	68	
SENTRY	105	
SUB TOTAL		1090
USAHAC		
DL & O	179	
PHY SECURITY	419	
HQ SECURITY	22	
TFC	9	
SUB TOTAL		629
SPECIAL OPNS		
TAY NINH RESUPPLY	26	
CHECKPOINTS	16	
OP RIFLE	3	
OP SHOTGUN	6	
OP PERSHING	50	
OP OREGON	35	
PRISONER/HOSPITAL GDS	75	
CONVOY ESCORT	12	
COMBAT SPT	36	
1ST INF DIV	18	
4TH INF DIV	9	
9TH INF DIV	9	
11TH ACR	22	
SUBTOTAL		308
GRAND TOTAL	3204	

Incl 4

52

# CONFIDENTIAL

AVBCC

16 March 1967

FOR OFFICIAL USE ONLY

39

MEMORANDUM FOR: PROVOST MARSHAL, UNITED STATES ARMY VIETNAM  
SUBJECT: CONARC Liaison Team Questionnaires

Inclosed are the completed questionnaires for the CONARC Liaison Team currently visiting USARV units.

/s/ THOMAS F. GUIDERA  
/t/ Colonel, MFC  
Commanding

FOR OFFICIAL USE ONLY

# FOR OFFICIAL USE ONLY

43

## Area of Interest - USA Military Police School

### Questions:

#### 1. Convoy and Escort.

-To what extent are military police involved with convoy and VIP escort missions?

-How are escort parties organized?

-What weapons or special equipment is utilized?

### Discussion:

a. The GVN has primary responsibility for the protection of VIP's visiting the Republic of Vietnam. However, the establishment and implementation of security measures is a joint US/GVN operation.

(1) Major subordinate commands under the operational control of I FFORCEV and II FFORCEV plan and execute necessary measures to insure the security of VIP's visiting their areas of responsibility.

(2) The CO, USAHAC (Saigon) provides military police for VIP security within the Headquarters Area Command area of responsibility.

(3) The CO, 18th Military Police Brigade, plans and executes security measures for each VIP within RVN, except as provided for in paragraph a.(1) above.

(4) Military police support for VIP security.

(a) Normally, one (1) officer and two (2) military policemen will accompany the VIP convoy during all movements in urban areas to provide emergency communications and reaction force support.

(b) Redlights and/or sirens are utilized only in an emergency.

(c) Military police will not lead the VIP vehicle(s) except in an emergency. This responsibility belongs to the ARVN military police or National Police, as appropriate.

(d) Traffic control outside US controlled installations remains a GVN responsibility; consequently US military police do not direct traffic except at the request of the ARVN military police, National Police, or in an emergency.

34

FOR OFFICIAL USE ONLY

## FOR OFFICIAL USE ONLY

(e) Bodyguards to provide security for VIP's are accredited criminal investigators assigned to the VIP security detail, at least one of whom will normally ride in the right-front seat of the VIP vehicle.

42

(5) Personnel. The requirement for security personnel varies for each mission and may range from three (3) to more than 130. They are organized, as necessary, to perform site security and command control, gate security, traffic control, or special roving patrols. In addition, reaction forces are placed on standby alert for emergency situations.

(6) Equipment. VIP security missions are performed utilizing the wide range of organic military police equipment; weapons, radios and vehicles. Special missions may require augmentation in the form of aircraft (surveillance) or special unmarked vehicles.

b. Elements of the 18th Military Police Brigade perform a convoy escort mission throughout the II and III CTZ's.

(1) Convoy composition will vary from a single march unit of five (5) vehicles to convoys of as many as 150 or more. Normally, a convoy will consist of several serials of approximately 30-50 vehicles each, and will not exceed 50. It has become customary for any convoy exceeding 50 vehicles to be broken down into serials. The organization of serials is normally determined by the type of vehicle, cargo carried, or destination, and not based simply on a specified number or formula.

(a) While the majority of convoys are logistical in nature and move all manner of supplies and equipment from depots to forward staging areas, the escort of replacement personnel from aerial ports to replacement centers is a continuing mission.

(b) Over the past eight (8) months, this Brigade has assisted in the escort of personnel and equipment of the 4th, 9th, and 25th Infantry Divisions, 196th and 199th Light Infantry Brigades, 11th Armored Cavalry Regiment, and the PHILCAG, from aerial and sea-ports to their respective staging areas in the interior.

(c) For the escort of critical convoys over "contested" routes, the military police escort is augmented by tactical unit vehicles, i.e., tanks and armored personnel carriers.

(2) The size and strength of a military police escort is normally tailored to the requirements of each convoy. However, the number of escort vehicles will vary with the resources available, convoy size, route(s) of march, and prevailing security conditions.

## FOR OFFICIAL USE ONLY

## FOR OFFICIAL USE ONLY

43  
(a) Within the limitations of equipment availability, the configuration of each escort vehicle is similar. The standard escort vehicle consists of the M-151,  $\frac{1}{2}$ -ton truck, with an M-60 machine gun mounted on a pedestal, and the AN/VRC-46 radio. Additional firepower is provided by an M-79 grenade launcher (normally 1 per 3 vehicles), and the individual weapons and hand grenades carried by the crew. In addition to standard OVM, equipment may include flashlights or lanterns, flares, water and rations (for extended missions), and any other equipment that individual and local experience has shown to be necessary.

(b) The crew consists of a driver, rider (assistant gunner), and a machine gunner, each wearing individual protective armor and steel helmet.

(c) A modular armor kit, or modification thereof, has been installed on the majority of vehicles used for convoy escort. A lack of sufficient armor kits, or the unsuitability of an "armored"  $\frac{1}{2}$ -ton for subsequent use for routine police patrol operations, particularly in built-up areas, precludes installation of armor on all vehicles. For these reasons, occasional requirements for military police escort of a large convoy will cause a "alick," or unarmored vehicle, to be employed. Lacking armor, these vehicles are employed in intermediate positions, or "floaters," moving the length of the serial or convoy for command and control purposes.

(d) As indicated earlier, military police escorts may be augmented with tactical vehicles for critical convoys, and travel over disputed routes. In addition, the route of march may be secured with tactical strongpoints at varied intervals, often provided by armored or mechanized units deployed for that purpose. These strongpoints serve the dual purpose of securing critical points on the route of march, and providing an instant reaction capability. Air support, when available, generally consists of spotter aircraft flying overhead. Medical air-evacuation, and helicopter flare and gunships, and other tactical aircraft are normally on standby alert. Also on-call are artillery support and the reaction forces of tactical units pre-positioned to provide direct support, or permanently stationed in the immediate area.

(3) Variations in escort techniques are caused principally by the length of the convoy and the nature of the terrain along the route of march.

(a) The "lead and trail" method is employed for small, easily controlled convoys, and over relatively secure routes. This technique involves one(1) escort vehicle positioned at the front of the column to establish convoy speed and lead it to the final destination. The trail escort vehicle follows the last vehicle in the convoy and is responsible for insuring that the vehicles keep together and notifying the lead escort vehicle of any unusual situation that develops. If a vehicle breakdown occurs, the trail vehicle remains behind to provide security until repairs are complete or recovery is affected.

## FOR OFFICIAL USE ONLY



## FOR OFFICIAL USE ONLY

44

(b) If the convoy consists of several serials with different starting times, each will be provided one (1) lead and one (1) trail vehicle as escort. In addition, there may be an escort OIC/NCOIC vehicle to assist the convoy commander as needed. Normally this vehicle will be positioned at the head of the first serial, but may change positions if the situation dictates.

(c) In situations where conflicting traffic or key intersections may cause problems for the convoy, a "modified lead and trail" method will be employed, involving TCP vehicles. The function of the TCP vehicle is to insure that the convoy is not stopped, broken up, infiltrated, or misdirected at critical intersections. Initially the TCP vehicles will line up behind the lead escort vehicle. As the convoy approaches the critical point or intersection, the lead escort will alert the pre-designated TCP vehicle to move up, take up its position, and secure the intersection. Once the convoy has passed, the TCP vehicle(s) will fall in behind the trail escort vehicle. Once they have performed their primary mission, the TCP vehicles can also be used to secure vehicles which have broken down enroute.

(d) A "leap-frog" technique augments the standard "lead and trail" method, with one (1) or more vehicles assigned to move up and down the length of the convoy for control purposes. This technique is handicapped by narrow, severely weathered roads, and the presence of other conflicting military or civilian traffic.

(e) A "point, lead and trail" technique involves the use of a point vehicle which moves approximately 5000 meters ahead of the lead escort vehicle to provide early warning of potentially dangerous situations, natural or deliberate. The lead, trail and any intermediate vehicles perform as previously indicated.

(f) The number of vehicles employed for any of the above techniques, or local variations thereof, will vary from two (2) to as many as nine (9).

### Question:

2. Are military police personnel used for the control or evacuation of the civilian population prior to or during combat operations? If so, briefly comment on the effectiveness of methods and techniques being used.

### Discussion:

a. The control and evacuation of the civilian population prior to and during combat operations is the primary responsibility

FOR OFFICIAL USE ONLY

45

## FOR OFFICIAL USE ONLY

of the military police assigned to the tactical units. Personnel of this Brigade have had only limited experience in direct support of tactical operations which involved civilian evacuation and control measures.

b. Depending on the purpose and scope of the tactical operation, the civilian population will either be moved a short distance from the actual or proposed battle area to a temporary location, or transported to a distant location for permanent resettlement.

c. The movement is accomplished on foot, by truck, or aircraft, depending on the distance to be covered and the availability of transportation. In any case, the refugees, with their personal belongings, livestock, and vehicles (if any) are collected in pre-designated, secure holding areas. Once organized and accounted for, they are escorted by the military police to pre-determined refugee camps, or to waiting aircraft. The purpose of the escort is to insure the safety of the refugees, to assist them if necessary, to prevent straggling, and to prevent their movement from disrupting tactical movement or operations.

d. Items of special interest.

(1) Realizing that the cattle and other livestock of the refugees are vital to their livelihood, it is essential that a holding area be provided for the animals, and provisions made to move them once the evacuation begins. In one case, military police vehicles were used to "herd" 200 head of cattle for several miles to a refugee camp. At all times, the considerate assistance given by military police personnel in the handling and escorting of refugees, their possessions, and livestock, will contribute much to our overall Civic Action Program in Vietnam.

(2) Experience has also shown that the use of barbed wire at either the initial assembly area(s) or at the refugee camp(s) should be avoided, as its use tends to incite panic among the refugees.

(3) It is important to insure that refugee camps are not located near the initial PW and detainee holding and interrogation camps. Many of the detainees or (PW'S) are known by, or related to the refugees, and this "close, but separated" arrangement may cause a serious morale problem for the refugees and/or a security problem for the military police.

Question:

3. To what extent are military police utilized for the handling of PW's and civilian detainees?

FOR OFFICIAL USE ONLY

FOR OFFICIAL USE ONLY

46

Discussion:

a. Effective 26 September 1966, the 18th Military Police Brigade assumed the mission of evacuating PW's from division/separate brigade PW collecting points to ARVN PW camps in the II (Pleiku) and III (Bien Hoa) CTZ's.

(1) Depending on the location of the collecting points, the evacuation is effected by vehicle, using ~~organic~~ military police or other available transportation, or by air (20 or more PW's).

(2) Brigade military police also evacuate PW's through medical and intelligence channels, and provide security for sick and wounded PW's at US medical facilities.

(3) Custody and accountability is assured by a specially tailored "capture card" (USARV Form 364) which accompanies the PW throughout evacuation and is retained ultimately at the USARV Provost Marshal Office.

b. The Brigade is not responsible for the security of evacuation of detainee personnel held by the capturing unit(s). Processing and status determination of detainees is made at the division/separate brigade collecting point, except for those who were evacuated directly to US medical facilities for treatment, prior to classification. In this case they are routinely guarded at the medical facility until a status determination can be made by IPW personnel, then released to the appropriate GVN authority, unless they are determined to be PW's.

c. Evacuation mechanics.

(1) The division/separate brigade provost marshal notified the MP Group (16th MP Gp in the II CTZ and the 89th MP Gp in the III and IV CTZ's) of a requirement to evacuate XX number of PW's. The Group notifies the appropriate subordinate unit of the mission, and if air transport is required, effects the necessary coordination. The Group also contacts the ARVN PW Camp and advises as to the number of PW's and their approximate ETA. Escort guards are briefed and move to the collecting point. The escort guards must insure that the necessary forms are complete, secure the PW's, and depart for the airfield, intermediate detention facility (if necessary), or move directly to the PW camp. At no time during the evacuation do the PW's leave the custody of the military police guards. At the camp, the ARVN stockade personnel receipt for the PW's and the "capture card" is forwarded to the USARV PMO for retention.

FOR OFFICIAL USE ONLY

FOR OFFICIAL USE ONLY

47

(2) Brigade military police guard sick and wounded PW's in US medical facilities and evacuate them to the ARVN PW Camp upon recovery. Constant coordination is required between the Brigade and the medical facilities to insure that the PW's are consolidated whenever practical, in a single ward or facility, to insure efficient utilization of guard personnel.

Question:

4. What are some of the methods and techniques employed in providing security to Harbors, Pipelines, and Installations?

Discussion:

a. In addition to the security measures outlined in FM 19-30, the following procedures are employed for harbor security in Vietnam.

(1) A 25-meter "kill zone" is established and enforced by military police around vessels berthed for unloading, riding at anchor, or moving up the river channels to inland port facilities. Only patrol craft and other official vessels may approach within this zone. All other craft are first warned away by voice and hand signal, then alerted by whistle, followed by a warning shot (if necessary). If the warnings are to no avail, the security personnel will "fire for effect."

(2) Floating debris which may conceal mines is occasionally fired upon, though caution is exercised because of port, harbor and river congestion.

(3) Harbor patrol craft are used for patrolling the harbors and to assist in the control of the large number of Vietnamese fishing and cargo vessels which constitute a potential hazard to port security efforts.

b. Pipeline security is a relatively limited Brigade mission and the procedures followed are in accordance with FM 19-30.

c. Installation security, which includes billets, headquarters, storage areas, ASD's, sentry dog operations, and the guarding of other facilities, utilizes a majority of Brigade personnel committed to our overall security mission. The most predominate employment is for point security, with military police or security guard personnel manning fixed positions, supplemented by roving foot and motor patrols, and supported by elaborate and dependable organic and augmented communications. Where applicable, these fixed positions coordinate with tactical air (flare and gunships) and artillery for additional support.

d. In addition to the security measures outlined in FM 19-30, the following measures are employed for installation security.

FOR OFFICIAL USE ONLY

40

FOR OFFICIAL USE ONLY

48

(1) A reserve force of military police or security personnel is designated as a reaction force in the event of an attack against a US facility. Their primary purpose is to seal-off the affected area(s) to prevent further damage or destruction, to aid in the care and evacuation of injured or wounded personnel, and to assist EOD personnel in locating additional explosive devices (if that is the case).

(2) Priorities of force. If an intruder advances toward a sentinel, a warning to halt is called, once in English, and three (3) times in Vietnamese. If the warning is ignored, the sentinel will fire at the lower extremities of the body to wound. If overtly attacked or fired upon, the sentinel(s) will "shoot to kill."

(3) Upon request, officers and non-commissioned officers of the Brigade provide physical security classes to non-military police personnel engaged in extensive physical security missions.

FOR OFFICIAL USE ONLY

## FOR OFFICIAL USE ONLY

49  
Proposed Questions For Colonel Rounsaville's Visit to Vietnam: Subject -

### Military Police Operations

#### Question:

1. The Commanding Officer, 18th Military Police Brigade, has expressed an interest to carry out airmobile operations by military police against "rice tax collectors." Has this type of operation been used, and if so, how effective has it been?

#### Discussion:

a. To date, operations against "rice tax collectors," utilizing Brigade resources have not been conducted. However, the concept was developed and training begun in October 1966, involving elements of the 720th Military Police Battalion at Long Binh (III CTZ). The training included:

- (1) The development and writing of an Operations Plan.
- (2) Formal classroom instruction.
- (3) Limited practical work involving squad and platoon tactical formations.

b. The aircraft required to support such operations have thus far not been available due to other high priority combat and combat support missions. As a result, training has been suspended. Should aircraft become available in the future, training could be resumed and actual operations begun, provided sufficient uncommitted personnel are available at the time.

c. Five (5) operations have been conducted by elements of the 25th Infantry Division against "rice tax collectors," but with negative results thus far.

#### Question:

2. What is the extent of coordination between military police and indigenous police in solving law and order problems? Have any specific problems been encountered?

#### Discussion:

a. Less than a year ago, joint police operations were non-existent, save for isolated requirements. Today, military police of

FOR OFFICIAL USE ONLY

## FOR OFFICIAL USE ONLY

50

Brigade are deliberately engaged in joint operations with Vietnamese civil, military, and Free World police forces in nearly every major city in the II and III Corps Tactical Zones, and several in the IV CTZ. Their scope varies from a single joint patrol, checkpoint or static post, to a complex, integrated effort that may include desk operations, walking, motorized or river patrols, traffic accident investigations, vice and black market control, checkpoints, static posts, etc. The city of Saigon is a notable example of both the scope and variety of joint operations.

b. It has become increasingly apparent that much of the operational success of the US police effort depends on the careful and patient development of close working relationships with Vietnamese police counterparts. Such relationships are particularly vital in overcoming jurisdictional and operational limitations which hamper the overall US police and security effort.

### c. Joint operations problem

(1) As in the United States, the jurisdiction of the National Police in Vietnam is limited by boundaries: city, provincial, district, sector, sub-sector, and other special areas of operation. Their authority beyond these boundaries can be extended only by the authority of a senior headquarters, and normally only for a specified period of time. Since most US military police areas of operation transgress National Police boundaries, joint operations must often be scheduled on a need basis within a specified area, rather than on a recurring, inter-area basis.

(2) National Police are both essential and desirable for the conduct of police raids and for any police activity in which jurisdiction may be questioned; traffic control points or resources control checkpoints, for example.

(3) While the National Police are "commanded" by the National Directorate in Saigon, their "operational" employment is often "adjusted" by province, district, or other local officials in the areas to which they are deployed. This makes it difficult to establish and maintain a measure of uniformity for training, equipping and employing National Police personnel at the operating level. This diffusion of "operational control" often results in a lack of "official backing" for police operations at the lower level. In turn, this situation breeds a general lack of confidence among the local police, as evidenced by the timidity on the part of the operating personnel and their general reluctance to exercise the authority they do possess. This situation affects not only their independent operations, but our joint police efforts as well.

## FOR OFFICIAL USE ONLY

43

## FOR OFFICIAL USE ONLY

51 (4) Joint operations are also hampered by the "language barrier." Few Vietnamese policemen speak or understand more than a few words of English, and few US military policemen speak or understand Vietnamese. Whenever possible, English-speaking National Policemen have been diverted specifically to joint police work, regardless of rank, previous assignment, or experience. US military policemen having some faculty for the Vietnamese language are likewise diverted. This remedial effort is further aided by the issue of English/Vietnamese phrase books, classroom language instruction, and the publishing of joint plans, special orders, SOP's, etc., in both languages.

(5) A lack of understanding on the part of US military personnel in general, and US military policemen specifically, as to the authority and jurisdiction of the National Police, is a constant source of friction. Only through continuous, directed training and intensive information and education programs regarding Vietnamese law and jurisdiction, can this problem area be "controlled." Joint police operations now underway have done much to assist our military policemen in understanding Vietnamese law and their police program.

**NOTE:** Question 3-7, pertaining to indigenous police operations in rural areas, lie beyond the realm of missions and scope of operations of the 18th Military Police Brigade. Therefore, the information provided to answer these questions reflects observations made during an interview with Mr. Robert French, Public Safety Advisor, III Region, Office of Civilian Operations, Republic of Vietnam.

### Question:

3. How much progress has been made in developing a proficient indigenous police force, especially in the rural areas?

### Discussion:

a. With few exceptions, progress has been extremely slow. The effectiveness of the local police forces is generally proportionate to prevailing security conditions in their respective operational areas. Wherever their personal safety is seriously and continuously threatened, the bulk of their efforts are expended in self-defense activity, with little time or energy remaining for the conduct of conventional police operations. In more secure areas, their influence is more evident and considerably more effective, with much less effort required to meet security needs. Below the provincial level, particularly in rural areas, their effectiveness in performing an actual police mission is at best, marginal.

b. Contributing to this ineffectiveness is the general lack of training among the majority of the police personnel. Unless they

FOR OFFICIAL USE ONLY



## FOR OFFICIAL USE ONLY

are given on-the-job or in-service training beyond initial basic training, their operational development is seriously hampered. 52

c. A manpower shortage also plagues the expansion of their operations in rural areas. Recruitment in these areas is slow due to the manpower drawn-off by the Vietnamese Army, Regional and Popular Forces, and the lack of inducements. Many cannot qualify for the National Police because they lack the educational requirements.

### Question:

4. How is the indigenous police force organized in the rural areas to protect against threats of the Viet Cong? Is this a police task? Is it Regional Force or Popular Force?

### Discussion:

a. Securing rural populations against Viet Cong threats and overt action is an ARVN, Regional or Popular Force mission, and not the National Police. They are not trained, equipped, or expected to operate (though many do) in areas where the Viet Cong threaten their very existence. Their primary responsibility regarding Viet Cong activity is to serve as an intelligence gathering agency to assist in "rooting-out" Viet Cong subversive elements.

### Question:

5. How have the police advisors to indigenous units influenced the organization and operations of these units?

### Discussion:

a. This is perhaps the most difficult aspect of the police advisory role, particularly at the lower levels. The overall organization of the National Police force structure is determined at the National Directorate level, and is not easily changed locally. This is due primarily to the reluctance of local officials to "obviously" differ with organizational directives.

b. However, "operational control" is an entirely different matter, for it is normally in the hands of the provincial, district or other local officials where it can be "molded" to suit local or personal preferences. The most effective means available to influence police operations, at almost any level, is for the advisor to control and closely monitor the utilization and employment of the equipment and other material resources allocated to his "counterpart."

FOR OFFICIAL USE ONLY

FOR OFFICIAL USE ONLY

53  
Question:

6. Have "shakedowns" of indigenous personnel developed those found with contraband as police informants? If so, are those persons exploited for the assistance they can give to the police?

Discussion:

a. The answer to both questions is NO! This calls for a sophisticated operation not yet achieved in the overall Vietnamese police effort.

b. There is a definite lack of coordination between the "Special Police" Branch of the National Police, a small organization capable of exploiting these and similar situations; and the elements of the National Police who actually operate the resources control check-points.

Questions:

7. Are indigenous persons found with contraband tried by their courts? If so, are convictions a deterrent to further acts?

Discussion:

a. Persons arrested for the "smuggl' " of illegal goods and commodities are normally tried by the Vietnamese courts. However, the courts appear to be rather lenient with offenders. Convictions are few, particularly if the offender can establish that the "smuggling" was committed under duress by the Viet Cong or some other illegal element of the population.

b. The convictions probably are a deterrent to further acts, particularly for the "first" offender. More significant however, is the reluctance of the Viet Cong to trust or "use" anyone who has been previously "identified" by the authorities.

Incl 5

FOR OFFICIAL USE ONLY