

UNCLASSIFIED

AD NUMBER

AD377920

CLASSIFICATION CHANGES

TO: unclassified

FROM: confidential

LIMITATION CHANGES

TO:

Approved for public release; distribution is unlimited.

FROM:

Distribution authorized to U.S. Gov't. agencies and their contractors;
Administrative/Operational Use; 30 NOV 1966.
Other requests shall be referred to Army Concept Team in Vietnam, APO San Francisco 96243.

AUTHORITY

30 May 1975, per doc markings; OACSFOR D/A ltr
13 Sep 1975

THIS PAGE IS UNCLASSIFIED

U167.5
N546

Army Concept 8722

~~CONFIDENTIAL~~

UNCLASSIFIED

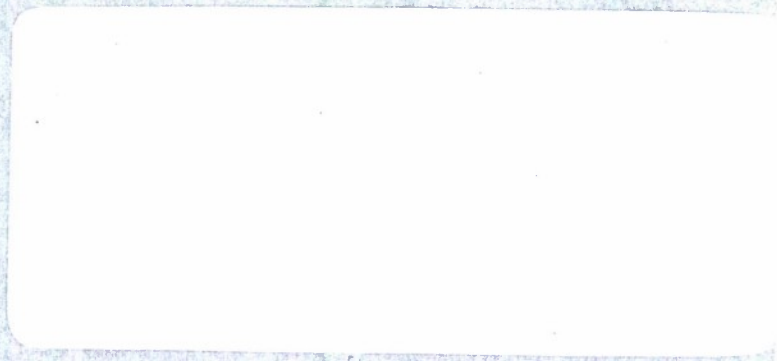

DOWNGRADED TO: UNCLASSIFIED
AUTH: *DoD 5200.1-R, Nov 1973*
DATE: *5-30-75* *bmb*

20090410 004

RECORDED
JAN 3 11 03 AM '68
ARMED FORCES
STAFF COLLEGE
NORFOLK VA

99081

ARMY CONCEPT TEAM IN VIETNAM
APO SAN FRANCISCO 96243

UNCLASSIFIED

~~CONFIDENTIAL~~

Qualified requestors may obtain
copies of this report from the
Defense Documentation Center

When this report is no longer needed it will
be destroyed in accordance with AR 380-5,
OPNAVINST 5510.1 B, AFR 205.1, or section 14
of the Industrial Security Manual for Safeguarding
Classified Information.

The findings, conclusions, and
recommendations of this report
will not be considered as offi-
cial Department of the Army
doctrine unless so stated by
proper authority in official
documents

~~CONFIDENTIAL~~

ARMY CONCEPT TEAM IN VIETNAM
APO San Francisco 96243

USE OF
NIGHT VISION DEVICES
BY
US ARMY UNITS
IN VIETNAM (U)

99081

~~CONFIDENTIAL~~

~~CONFIDENTIAL~~

ARMY CONCEPT TEAM IN VIETNAM
APO San Francisco 96243

ACTIV-GCD

24 December 1966

SUBJECT: Final Report - Night Vision Devices (ACG-25F) (U)

TO: See distribution annex to inclosed report

1. The inclosed report, subject as above, is forwarded for information and retention.

2. The findings, conclusions, and recommendations of the report are based solely on data generated through the Army Concept Team in Vietnam and are not to be considered as Department of the Army doctrine until incorporated in official documents.

Merrill G. Hatch

1 Incl
as (cy)

MERRILL G. HATCH
Colonel, Artillery
Chief

Regraded unclassified
when Seperated from
Classified Inclosures

~~CONFIDENTIAL~~

~~CONFIDENTIAL~~

U.S. ARMY CONCEPT TEAM IN VIETNAM,
APO San Francisco 96243

FINAL REPORT

USE OF
NIGHT VISION DEVICES
BY
US ARMY UNITS
IN VIETNAM (U)

ACTIV Project No. ACG-25F

30 November 1966

Approved:

Arthur L. Woodruff
COL ACTIV
for

MERRILL G. HATCH
Colonel, Artillery
Chief

DOWNGRADED AT 3-YEAR INTERVALS
DECLASSIFIED AFTER 12 YEARS
DOD DIR 5200.10

~~CONFIDENTIAL~~

AUTHORITY

Letter, AGAM-P(M) (17 Jul 64) ACSFOR, DA,
31 Jul 64, subject: Army Troop Test Pro-
gram in Vietnam (U), as amended.

CINCPAC Message DTG 312019Z Jan 66

ACKNOWLEDGMENTS

The Army Concept Team in Vietnam is indebted
to the following US Army units for their help
in the evaluation:

1st Infantry Division
1st Cavalry Division (Airmobile)
1st Brigade, 101st Airborne Division
173rd Airborne Brigade (Separate)

PROJECT OFFICERS

Lt Colonel James D. Kennedy, Artillery
Lt Colonel John G. Hayes, Armor
Major Ed E. Jones Jr., Signal Corps

EVALUATORS

CPT McKinley Hudson, Artillery
1/Lt Willie E. Griffith, Artillery
1/Lt Wallace T. Bonaparte, Infantry
1/Lt Robert E. Wantland, Armor

99918

U167.5
.N5U6

CONTENTS

	<u>Page</u>
SUMMARY	v
I. INTRODUCTION	
A. Purpose	1
B. Background	1
C. Definition of Terms	2
D. Description of Materiel	2
E. Objectives	4
F. Evaluation Design	5
II. DISCUSSION	
A. Objective 1 - Tactics and Training	9
B. Objective 2 - Performance	17
C. Objective 3 - Maintenance and Logistics	25
D. Objective 4 - Basis of Issue	27
III. CONCLUSIONS AND RECOMMENDATIONS	
A. Conclusions	31
B. Recommendations	32
ANNEXES	
A. Detailed Description of Materiel	A-1
B. Employment Statistics	B-1
C. Maintenance Situation as of 3 May 1966	C-1
D. Distribution	D-1

FIGURES

<u>Figures</u>	<u>Page</u>
1. Small Starlight Scope Mounted on M16 rifle.	12
2. Starlight Scope Small, Hand-Held	12
3. Crew-Served Night Vision Sight Used in Conjunction with the AN/PPS-4 Radar Set.	15
4. Crew-Served Night Vision Sight Mounted on AN/PPS-4 Radar Set Tripod	15
5. Small Starlight Scope Collet and Locking Lever for Focusing Knob	23
A-1. Small Starlight Scope, External View.	A-2
A-2. Crew-Served Night Vision Sight, External View.	A-2
A-3. Small Starlight Scope, Objective Lens Assembly	A-3
A-4. Crew-Served Night Vision Sight, Objective Lens Assembly	A-4
A-5. Small Starlight Scope, Reticle Pattern (7), and Assembly	A-5
A-6. Crew-Served Night Vision Sight, Reticle Pattern	A-7
A-7. Small Starlight Scope, Oscillator.	A-7
A-8. Small Starlight Scope, Eyepiece Assembly	A-8
A-9. Crew-Served Night Vision Sight, Right-Angle Eyepiece Assembly	A-8
A-10. Crew-Served Night Vision Sight, In-line Eyepiece Assembly.	A-9

~~CONFIDENTIAL~~

SUMMARY

The purpose of the project was to evaluate first generation night vision devices (Starlight Scope, Small Hand-Held or Individual Weapon Mounted and Crew-Served Weapon Night Vision Sight) used by US Army units in the Republic of Vietnam (RVN) to obtain data on tactical employment, system performance, maintenance experience, and suitability of the Department of the Army basis of issue.

From February to July 1966, the Army Concept Team in Vietnam (ACTIV) collected data through personal observation by evaluators, interviews with using personnel, completion of questionnaires, and examination of reports, journals, and equipment records. These data were then analyzed by ACTIV evaluators and project officers using descriptive, quantitative, and qualitative methods. Because the evaluation was made under actual combat conditions, assigned missions of the tactical units governed the employment of the night vision devices (NVD) and influenced the data collection capability.

The evaluation disclosed that the NVD was effectively employed in both offensive and defensive operations, and that its operational limitations were primarily those imposed by weather, terrain, and vegetation, rather than design.

It was concluded that the NVD are of significant value to the combat soldier in Vietnam. Adoption of the recommended Department of the Army basis of issue and introduction of additional NVD into Vietnam before conclusion of the field evaluation were fully justified by the findings and conclusions of the study.

The utilization of Night Vision Devices from USAF or USA aircraft was not included as an objective within the scope of this evaluation. However, the adaptability of this equipment for use from O-1 and AG-47 aircraft was the subject of a final letter report dated 12 May 1966, prepared by the Air Force Test Unit Vietnam, APO 96243. In addition, Headquarters, United States Military Assistance Command, Vietnam, APO 96243, has published a document, "Counterinsurgency Lessons Learned No. 59, Employment of Image Intensification Devices (U)." Within this document are included comments relative to the use of NVD from O-1E aircraft and for air surveillance.

~~CONFIDENTIAL~~

THIS PAGE NOT USED

~~CONFIDENTIAL~~

I. (C) INTRODUCTION

A. PURPOSE

The purpose of the project was to evaluate first generation night vision equipment used by US Army units in the Republic of Vietnam (RVN) as to employment, system performance, maintenance experience, and suitability of Department of the Army basis of issue.

B. BACKGROUND

One of the primary advantages possessed by the insurgent in Vietnam is his ability to move undetected under cover of darkness. On numerous occasions the insurgents have used the cover of darkness to carry off successful attacks against US installations and defensive positions. Early detection or observation of the insurgents would have aided in defeating these attacking forces. This need for improved observation at night in Vietnam stimulated the early deployment of night vision devices which were under consideration by US Army Engineer Research and Development Laboratories. On 13 September 1965, the Military Assistance Command, Vietnam (MACV) received information that limited quantities of the following night vision devices would be made available for use in RVN: Small Starlight Scope (SSS), Hand-Held or Individual Weapons Mounted; Crew-Served Weapon Night Vision Sight (CSWS); Medium Range Night Observation Device (NOD); and Helmet Mounted Infrared Binoculars (IRB).

On 16 October 1965, US Army Vietnam (USARV) requested that one battalion-size packet of the night vision devices be shipped to Vietnam for evaluation by the Army Concept Team in Vietnam (ACTIV) at the earliest possible date. During the preliminary investigation, all four major US Army tactical units in Vietnam expressed a desire for the devices and submitted to USARV the number of each type of device they required. Considering the desires of the units, ACTIV suggested to the US Army Materiel Command deputy project manager for night vision devices that the evaluation be expanded to include all four major US Army units then in Vietnam. On 20 November 1965, Headquarters, Department of the Army directed USARV to conduct evaluations of the night vision equipment with these four major Army organizations.

On 24 November 1965, a training team consisting of three officers, four enlisted men, and one civilian arrived in RVN from Fort Benning, Georgia, to give introductory instructions on the NVD to user unit personnel.

~~CONFIDENTIAL~~

The evaluation was referred to ACTIV for action on 29 November 1965. It was planned originally to evaluate all four models of NVD but the NOD and IRB did not arrive in RVN early enough to be included in the evaluation.

Initial battalion packets (60 SSS and 8 CSWS) were received by the 4 major units concerned between mid-January and mid-February 1966 and were distributed to selected line units. Additional packets were made available as they arrived in Vietnam.

The evaluation team, consisting of four officers, arrived in Vietnam on 25 February 1966. Each officer was assigned to one of the major US Army units concerned. The evaluators utilized questionnaires and personal interviews with equipment operators and unit commanders to collect data. The evaluators accompanied units on operations and made personal observation of the equipment and its employment.

C. DEFINITION OF TERMS

1. Night Hawk Control - Aviation Operations Center of the 3rd Brigade, 1st Infantry Division.
2. Project Code ZIM - A commodity code used to expedite the resupply of parts of NVD.
3. Red Haze - Another name for the method of detection which employs airborne infrared heat seeking equipment in locating targets.
4. Resolution - The capability of making distinguishable the individual parts of an object, closely adjacent optical images, or sources of light.

D. DESCRIPTION OF MATERIEL

1. Starlight Scope Small Hand-Held or Individual Weapons Mounted (FSN 1090-688-9954)

The starlight scope is a small, light weight, passive night vision image intensifier system used for visual observation and to provide aimed fire of weapons at night, under ambient light conditions, with maximum security from detection. The system is capable of employment as a hand-held viewer or as a weapon-mounted sight on basic infantry weapons. The small starlight scope consists of an objective lens, image intensifier tube, eyepiece, power supply, and reticle assembly.

CONFIDENTIAL

The starlight scope, along with its canvas carrying case, spare batteries, reticle lamps, receiver mount assembly, allen wrenches, and lens tissue, is delivered in a metal shipping container which is designed to protect the device during movements of any appreciable distance. Detailed characteristics are:

- | | |
|-------------------------|---|
| a) Stated range | To 400 meters depending on ambient light conditions |
| b) Magnification | 4 power |
| c) Field of view | Approximately 10 degrees |
| d) Eyepiece focus | Adjustable from minus 4 to plus 4 diopters |
| e) Objective lens focus | 4 meters to infinity |
| f) Weight | 5.91 pounds |
| g) Length | 13.86 inches |
| h) Width | 3.35 inches |
| i) Height | 5.52 inches |
| j) Battery | 6.75 volt mercury BAL100/U (disposable) |
| k) Classification | Confidential |

2. Crew-Served Weapons Night Vision Sight (FSN 1090-911-1370)

The crew-served weapons night vision sight provides the capability for battlefield surveillance, target acquisition, and delivery of aimed fire from crew-served weapons at night, with security from enemy detection. It is a passive sight which uses ambient light for viewing and consists of a sight housing, an eyepiece, an image intensifier tube and reticle projector, an objective lens, and power supply. This sight is shipped in a metal carrying case, which also contains spare batteries, reticle lamps, a right angle eyepiece, and lens tissue. Mounting brackets will be provided for attachment and use on a variety of crew-served weapons.

CONFIDENTIAL

Detailed characteristics are:

- | | |
|-------------------------|---|
| a) Stated range | To 1000 meters, depending on ambient light conditions |
| b) Magnification | 7 power |
| c) Field of view | Approximately 5.5 degrees |
| d) Eye piece focus | Adjustable from minus 4 to plus 4 diopters |
| e) Objective lens focus | 50 meters to infinity |
| f) Weight | 15 pounds |
| g) Length | 24.75 inches (w/in-line eye piece) |
| h) Width | 6.31 inches |
| i) Height | 7 inches |
| j) Battery | 6.75 volt mercury BA1100/U (disposable) |
| k) Classification | Confidential |

A detailed description of the SSS and CSWS and their component parts may be found in annex A.

E. OBJECTIVES

1. Objective 1 - Tactics and Training

Describe and evaluate tactics and training for use of night vision devices as developed by using units in night operations in RVN.

2. Objective 2 - Performance

Describe and evaluate system performance for each type of night vision device.

3. Objective 3 - Maintenance and Logistics

Describe and evaluate the maintenance and logistic support requirements for each type of night vision device evaluated.

~~CONFIDENTIAL~~

4. Objective 4 - Basis of Issue

Evaluate the suitability of the Department of the Army basis of issue for each type of night vision device. If the Department of the Army basis of issue is not suitable, recommend a basis of issue for each device.

F. EVALUATION DESIGN

1. Setting of the Project

a. Environment

The evaluation was conducted primarily in the II and III Corps Tactical Zones (CTZ) of RVN. Terrain in the evaluation area varied from flat areas along the coast, to hills, mountains, and valleys in the central highlands. Vegetation varied from open areas with paddies, to rubber plantations, to thick jungle canopy and undergrowth.

From May through October frequent rain, high humidity, and tropical temperatures are characteristic of these areas. The period from November through April is characterized by slightly higher temperatures and very little precipitation. The NVD were used during all phases of the moon, on clear and partly cloudy nights, and during periods of rain and fog.

b. Units

Four US Army tactical units in Vietnam participated in the evaluation. The units were the 1st Cavalry Division (Airmobile), 1st Infantry Division, 173rd Airborne Brigade (Separate) and 1st Brigade of the 101st Airborne Division. The battalions that had received training from the introductory training and maintenance team from Fort Benning, Georgia participated in the evaluation.

2. Methodology

a. Data Collection Methods

Data were collected by the ACTIV evaluators. They observed operations of the major US Army units in Vietnam selected for the evaluation and recorded their observations. Interviews were conducted with a total of 127 individuals of the evaluation units. Out of the total number of users interviewed, 123 were officers and enlisted men assigned to infantry units at company level or below.

~~CONFIDENTIAL~~

~~CONFIDENTIAL~~

The remaining four individuals included two maintenance personnel, one artillery officer functioning as a forward observer, and one helicopter pilot. A review of the unit's maintenance records was also included in the accumulation of data.

b. Analysis Methods

A comparative qualitative and quantitative analysis was made from the direct observations of evaluators and interviews of equipment operators and commanders in order to determine tactics and techniques employed, and performance of the equipment under the existing requirements in RVN. Maintenance and logistic records of the support maintenance units were examined to determine performance and maintenance problems.

3. Limitations and Variables

The NVD were issued to units which were engaged in combat operations in Vietnam. These operations precluded any form of controlled testing and restricted the collection of some data. Devices to measure ambient light and cloud conditions were not available. Conduct of the normally assigned missions of the tactical units governed the employment of equipment and influenced the data collection capability.

4. Support Requirements

a. Personnel

Four officer data collectors were assigned TDY to ACTIV for a period of 120 days. Each was a captain or 1st lieutenant of the combat arms with rifle platoon or firing battery experience.

b. Equipment

Four battalion packets of night vision devices were furnished by the US Army Materiel Command. The battalion packets were furnished in accordance with the following DA basis of issue:

- 1) Infantry Division (1 each): 60 SSS and 8 CSWS.
- 2) Cavalry Division (Airmobile) (1 each): 60 SSS and 8 CSWS.
- 3) Airborne Brigade (2 each): 120 SSS and 16 CSWS.

Brackets for mounting the SSS were furnished for the M-14 and M-16/XM16E1 rifles, and the M60 machinegun.

~~CONFIDENTIAL~~

~~CONFIDENTIAL~~

Brackets for mounting the crew-served weapon sights were furnished for the caliber .50 machinegun.

c. Upon completion of the evaluation, ACTIV turned property accountability over to the US units which used the NVD.

5. Time Schedule

a. 24 November 1965 - Introductory training and maintenance team arrived in Vietnam.

b. 15 January through 15 February 1966 - Arrival of four battalion packets of night vision devices in Vietnam.

c. 24 January 1966 - Departure of introductory training and maintenance team.

d. 25 February 1966 - Arrival of evaluators in Vietnam.

e. 6 March 1966 - Start of the data collection.

f. 16 May 1966 - Completion of data collection.

LIBRARY
ARMED FORCES STAFF COLLEGE

7

~~CONFIDENTIAL~~

1999/6

THIS PAGE NOT USED

~~CONFIDENTIAL~~

II. (C) DISCUSSION

A. OBJECTIVE 1 - TACTICS AND TRAINING

The purpose of this objective was to describe and evaluate tactics and training for the Starlight Scope, Small (SSS), Hand-Held or Individual Weapon Mounted, and Crew-Served Weapons Night Vision Sight (CSWS) as developed by US Army forces for night operations in RVN.

Data collection for this objective covered the employment of the two night vision devices in offensive and defensive operations, transportation of the NVD during combat operations, and individual and unit training requirements.

1. Offensive Use

With the exception of ambushes and reconnaissance patrols, night offensive operations by US units are limited in the RVN. During the evaluation, none of the participating units were involved in large scale night combat operations such as raids or attacks on enemy positions. Therefore, there is no evidence as to what extent the NVD would have increased the effectiveness of US troops had they been used in a large scale night operation.

The SSS was used in the night ambush. Even though US units in RVN use the night ambush more as a defensive than as an offensive tactic, the ambusher preserves the initiative of beginning or avoiding the conflict and is thus considered to be in an offensive posture no matter what the ultimate aim of the ambush may be.

Ambushes were used to supplement the regular defensive positions of a unit area. They were placed fairly close (3,000 meters or less) to the defensive perimeter to cover likely avenues of approach. They provided early warning of the enemy advance, thereby disrupting his plans and organization and enabling kills to be made. The SSS mounted on the M-14 and XM-16E1 rifles and M-60 machinegun was used successfully in this type of operation. Almost all the scope users interviewed had employed the SSS on this type of mission. The SSS was used to observe and monitor the area surrounding the ambush site both prior to and during its establishment.

Although there was normally only one SSS per ambush, continuous surveillance could be maintained with it on approaches to the killing zones. The increased observation range provided by the SSS lengthened the time the ambush party had for making final preparations once the enemy had been detected moving toward the trap. Thus, the use of the

~~CONFIDENTIAL~~

CONFIDENTIAL

device provided the commander with a degree of selection and discrimination of targets rarely offered in conduct of ambushes under cover of darkness. Approximately half the SSS users were able to direct fire of the other squad members at targets in the killing zone, thus greatly increasing the effectiveness of the ambush. Increased emphasis in this area through formal training and practice is indicated.

It has been the practice of US troops to plan fires of supporting weapons on the ambush site. Because of the close proximity of friendly troops to the planned concentrations, these fires are seldom used while troops remain on position. However, when an ambush site has become untenable and the friendly troops are forced to withdraw, planned fires are used to cover their withdrawal by killing, confusing, and disorganizing the pursuing enemy troops. Also, targets of opportunity sometime appear at a great enough distance from friendly troops to enable them to use the preplanned concentration as reference points from which they can adjust indirect fire. Twenty-one percent of the operators questioned had used the SSS to select targets for supporting weapons such as mortars and artillery or to aid in the adjustment of these fires when they became necessary.

An ambush patrol of the 2/28 Infantry, 1st Infantry Division, located at Lai Khe, used the SSS to detect a company-size Viet Cong (VC) force moving toward their position. As the patrol prepared to open fire, the patrol leader discovered a second company-size VC force a short distance behind the first group. The patrol leader allowed the first unit to pass and then ambushed the second one. The first group of VC then returned to the ambush site and entered the fight. In the confusion, the two VC fired on each other while the friendly patrol withdrew toward the 3rd Brigade perimeter and called for artillery fire support. Although the patrol leader was killed during the engagement, the surviving platoon sergeant and several members of the patrol stated that they could not have detected the second group of VC without the SSS. The platoon sergeant credited the SSS with having provided decisive information to the patrol and stated that it was one of the most useful pieces of equipment he had ever used in combat.

Reconnaissance patrols were the only other type of night offensive action undertaken by US units during the evaluation period. On the reconnaissance patrols the SSS contributed to the security of the patrols by providing an added surveillance capability during movement. In addition, respondents said that the SSS aided in maintaining direction and control and in speeding up the advance of the patrol. It also enabled individuals with compasses to pick out landmarks at a much greater distance for use as reference points. This allowed the patrol to reduce the number of halts necessary to verify their position and enabled them to move at a faster than average pace. The SSS was

CONFIDENTIAL

~~CONFIDENTIAL~~

used to check danger areas, including clearings, stream beds, and other possible ambush sites before entering them. The SSS enabled patrol members to obtain a much more accurate view of patrol objectives from a favorable stand-off distance without compromising their own location. The SSS was also used by patrols to assist passage through friendly forces.

A typical patrol action took place when a patrol from the 2nd Battalion, 502nd Infantry, 101st Airborne Division operating southwest of Tuy Hoa was returning to its lines. Their instructions were to return along a specific rice paddy dike which led into the platoon perimeter. The problem was to distinguish the correct dike from the large number of other dikes to the front of the friendly position. The patrol leader requested that a guide be stationed on the end of the dike concerned. Using the SSS, the patrol leader was able to observe the guide at a distance of 300 meters and lead the patrol safely back into its lines. Without the SSS, the patrol would have had to approach much closer to the platoon perimeter to locate the correct route and thus have faced the danger of being mistaken for a VC force.

In no instance was the CSWS used on an ambush or reconnaissance patrol. The weight of the device and its associated weapon made its use impractical for this type of operation.

2. Defensive Uses

It was observed that the NVD were universally more favored for use in the defense than in the offense. During the evaluation there were six or seven SSS per company-size unit and, when a patrol or ambush was sent out, only one SSS would be sent with it, while the other five or six were used in the company defense positions. Both the SSS and CSWS were used extensively and effectively in various static defense configurations. Of the 127 men interviewed, 118 of them had used the NVD to make possible the early detection and identification of enemy night movement. The standard defense during this period was a circular perimeter using listening and observation posts at key positions outside the perimeter (figure 1 and 2). The SSS was used on each listening and observation post and on the perimeter. The CSWS on the caliber .50 machinegun was also used by the 1st Cavalry Division (Airmobile) in night route security missions on Highway 19. During these times, the CSWS was used effectively with the caliber .50 machinegun in the same manner as the SSS when mounted on either the M14 or M16 rifles. Since there were no mounting brackets for use of the CSWS on the 106mm recoilless rifle during the evaluation period, the device was not used with this weapon.

The mission of each NVD operator on static defense was to detect and identify enemy activity as early as possible and to identify the exact target area to the rest of the defending personnel. When required,

~~CONFIDENTIAL~~

~~CONFIDENTIAL~~



(C) FIGURE 1. Small Starlight Scope mounted on M16 rifle.



(C) FIGURE 2. Small Starlight Scope, hand-held.

~~CONFIDENTIAL~~

CONFIDENTIAL

the NVD operator would call for immediate overhead illumination or he would fire tracer rounds into the target area. On occasion, the flash of an exploding M79 grenade was sufficient to identify the target area. If enemy troops were detected within hand grenade range of the perimeter, a white phosphorus grenade was used for marking purposes. Thirty-three percent of the NVD operators had had the opportunity to select targets for indirect fire. Artillery and mortar fires were then accurately adjusted on these targets through the use of the NVD.

A typical defensive employment of the SSS occurred on 15 March 1966. An element of the 173rd Airborne Brigade in VC War Zone "D" had an observation post established as part of its perimeter defense. At 0100 hours, under ambient light conditions similar to a 1/2 moon, the soldiers scanning the area through the SSS detected and identified six enemy troops moving along the adjacent ridge line. The operator adjusted fire on the target. At the completion of the fire mission, the operator was able to make a body count of the results. Another example occurred during the month of March 1966 when the 1st Battalion, 5th Cavalry, 1st Cavalry Division, conducted a mission to secure route 19 at the An Khe Pass. For six consecutive nights (23 to 28 March), the VC probed and attempted to infiltrate the battalion command post area. Each time, they were detected well out of hand grenade range, under ambient light conditions varying from new moon to 1/4 moon, by the operators of three SSS located on OP's manned by the reconnaissance platoon. By calling for illumination and mortar support and by marking the target area with tracer rounds, enough firepower was placed on the VC to repel their attempts. During this period three VC were confirmed killed, four were captured, and evidence of other casualties was found.

The NVD were used to secure the units' rear areas and flanks and to identify friendly patrols and aid in their passage of lines by observation and signalling.

One other use of the NVD in the defense cited by the operators was that of locating snipers. Forty-five percent of the operators said that they were successful in locating distant muzzle flashes in an area where snipers were concealed or that they were able to see the sniper himself. The CSWS was particularly good for this because of the long range from which snipers usually operate. Once the sniper's position had been located, the NVD operator placed direct fire on it or called for indirect fire.

Respondents stated that the increased ability to see at night enhanced the effectiveness of the defensive positions and improved the confidence and morale of personnel manning the positions.

CONFIDENTIAL

~~CONFIDENTIAL~~

The CSWS was used in conjunction with the AN/PPS-4 ground surveillance radar system at the 3rd Brigade, 1st Infantry Division Base Camp, at Lai Khe. The CSWS and radar set were located in a tower 75 feet high. The CSWS was mounted on an AN/PPS-4 radar set tripod, which proved to be an effective and stable expedient (figures 3 and 4). The CSWS provided effective range surveillance for approximately 1800 meters along the southern portion of the camp perimeter. The radar set was able to pick up moving objects as far away as Ben Cat (6,000 meters). The CSWS was used by the radar operators to verify stationary and moving targets which had been initially identified by the radar. On several occasions, the radar operator detected activity along the Lai Khe-Ben Cat Road. This activity was identified through the CSWS as VC who appeared to be mining the road. Artillery fire was placed on these targets but a body count was not established. However, on two occasions bloodstains and abandoned enemy equipment were found later.

3. Carrying Methods

There were two methods used to transport the SSS into the area of operations. The 1st Brigade, 101st Airborne Division and the 173rd Airborne Brigade preferred to have the individual operators carry the SSS in the canvas carrying case with them on their initial entry into the combat zone. The 1st Infantry Division and 1st Cavalry Division preferred to have the SSS brought to the combat zone in the issued metal shipping containers after the landing zone had been secured for the resupply helicopters. All major units transported the CSWS in the metal shipping containers into the combat area by helicopter or truck. Since the majority of operations took place in daylight, unit commanders did not want the troops burdened with the additional weight of the NVD throughout the day. This also decreased the possibility of damage to the NVD and the possible loss or compromise of classified materiel.

After reaching the combat area, the SSS were transported in the canvas carrying case which was attached to the operator's combat harness during daylight. At night, the SSS were either mounted on a weapon for use in surveillance and conduct of aimed fire or shoulder slung by means of an improvised carrying strap. There were no actual requests for a carrying strap but indications were that if one could be devised and included as a basic issue item, it would be useful.

The CSWS was normally used with the caliber .50 machinegun and it was the weight of this weapon rather than that of the CSWS that restricted its use to static or semi-static defense positions. The CSWS was used independently of the caliber .50 machinegun in conjunction with the AN/PPS-4 radar system utilizing the AN/PPS-4 tripod with excellent results as previously noted.

~~CONFIDENTIAL~~

~~CONFIDENTIAL~~



(C) FIGURE 3. Crew-Served Night Vision Sight used in conjunction with the AN/PPS-4 radar set.



(C) FIGURE 4. Crew-Served Night Vision Sight mounted on AN/PPS-4 radar set tripod.

~~CONFIDENTIAL~~

~~CONFIDENTIAL~~

4. Training

Initial formal instruction on the night vision devices was given by an instructor team from the US Army Infantry School at Fort Benning, Georgia. This team was prepared to instruct a class of 50 students per day from 6 December 1965 to 22 January 1966, including company commanders, platoon leaders, and additional instructor personnel to facilitate future training. The instruction given by this team only included the operation and maintenance of the NVD. It did not attempt to provide the units with any doctrine for the tactical employment of the NVD.

It was determined during the evaluation that because of replacements through rotations and casualties, the number of formally trained operators decreased, while the number of informally or unit trained operators substantially increased. This loss of formally trained personnel apparently had little effect on proper utilization of the equipment. In many instances, a soldier first became acquainted with a NVD when it was issued to him for use. The simplicity of operation, combined with a few minutes of informal instructions, enabled the operator to use the NVD effectively with minimum delay and minimum damage to components.

It was noted by most unit commanders, however, that formal training should be required for all personnel on the operation and maintenance of the NVD. A 1-hour period of instruction was considered sufficient to provide using personnel with the information necessary for proper utilization of the equipment. The program of instruction should include operation, maintenance, and practical work with particular emphasis on zeroing and bore sighting techniques. No special training areas or equipment were considered necessary except for zeroing. When a known distance range was not available, zeroing was accomplished by using tracer ammunition to mark the strike of the round and adjusting the reticle at 150 meters for the SSS and 1000 meters for the CSWS. This 1-hour was considered the minimum required and included no provision for tactical training on the NVD in unit night operations.

5. Findings

a. The SSS was used effectively on ambushes and reconnaissance patrols in night offensive actions.

b. The CSWS was not used on night ambushes and reconnaissance patrols because of its weight and bulk.

c. The use of the NVD in RVN did not result in a change in night offensive operations or tactics.

~~CONFIDENTIAL~~

~~CONFIDENTIAL~~

d. The SSS and CSWS, when employed in a static defense role, provided early warning, helped identify enemy movement, assisted in the adjustment of fires, and facilitated the passage of friendly patrols through their own lines.

e. The CSWS was used effectively by the 3rd Brigade, 1st Infantry Division to augment the AN/PPS-4 ground combat surveillance radar for more rapid and accurate location of enemy targets.

f. The weight of the SSS did not adversely affect its employment.

g. The SSS and CSWS were operated effectively by personnel who had received less than 1 hour of formal instruction.

h. An improvised carrying sling was used to assist in carrying the SSS at night.

i. The CSWS was effectively utilized as a surveillance device not associated with a weapon when mounted on AN/PPS-4 tripod.

B. OBJECTIVE 2 - PERFORMANCE

This objective was established to describe and evaluate the performance of the NVD in RVN during the evaluation period. Areas considered were combat effectiveness of the NVD for night surveillance, limitations imposed by environmental factors, design suitability, and the use of artificial sources of illumination. Source data utilized were obtained from observations, reports of using and maintenance support units, and questionnaires completed by 127 selected personnel including NVD operators, unit commanders, and maintenance personnel. Several descriptions of the actual use of the NVD in combat were also recorded to better describe the conditions under which the devices were evaluated and used.

1. Operational Environment

The 1st Brigade, 101st Airborne Division, the 173rd Airborne Brigade, the 1st Cavalry Division, and the 1st Infantry Division were engaged in combat operations during the evaluation in areas of widely varying terrain and vegetation conditions.

The operations of the 1st Brigade of the 101st Airborne Division, which took place along the coast in the vicinity of Tuy Hoa, were conducted in open, flat areas covered with rice paddies and in mountainous terrain covered with heavy vegetation. Their mission was to protect the rice crop harvest of this area and to deny its use to the Viet Cong in the mountains and valleys. The ranges of targets observed by the personnel who used the SSS routinely exceeded 200 meters and, in several

~~CONFIDENTIAL~~

~~CONFIDENTIAL~~

cases, exceeded 500 meters.

Counter-guerrilla operations of the 173rd Airborne Brigade were conducted in VC War Zone "D". The terrain was hilly and covered with dense vegetation. As a result of the heavy vegetation encountered in this area, the usable range of the NVD was considerably reduced, and in only two instances were targets able to be observed at a distance greater than 500 meters.

Operations of the 1st Cavalry Division (Airmobile) were conducted in the Central Highlands in dense vegetation. Their mission was to provide route security for Highway 19 from the left flank of the ROK Tiger Division to approximately 10 kilometers west of An Khe. The terrain and vegetation encountered limited the usable range of the SSS to less than 400 meters.

The 1st Infantry Division conducted operations in the Ben Cat-Lai Khe area which was characterized by flat terrain that was open in some spots and, in others such as in the Michelin Rubber Plantation, heavily wooded. The experiences gained by the 1st Infantry Division troops were comparable to those of the 1st Brigade, 101st Airborne Division. In areas where vegetation was sparse, usable ranges exceeded 200 meters and, in some cases, 500 meters. In heavily wooded areas usable ranges varied between 100 and 200 meters.

2. Range

The rated range of the SSS is 400 meters. However, this range is not significant without consideration of the ambient light and tactical parameters involved. The maximum range obtainable may be a result of either the terrain or of scope capability, whichever is the most restrictive.

A review of the data describing the terrain in which 333 operations were conducted shows that a little less than half, 151, were conducted in conditions ranging from no vegetation to vegetation consisting of bushes under 4 feet in height. The remaining 182 operations were conducted in areas ranging from lightly wooded to dense jungle canopy. Thus, on 55 percent of the operations, the usable range of the NVD was restricted by the tactical environment. This correlates directly with the report that maximum usable range of the SSS on 30 of 105 operations was less than 200 meters. Of the remainder of the operations, usable ranges from 200 to 500 meters were reported on 48, and ranges over 500 meters were reported for the remaining 27.

No instances were reported where the range capability of the SSS was a limiting factor in its tactical employment. Operations were conducted under conditions ranging from cloudy to clear and from

~~CONFIDENTIAL~~

~~CONFIDENTIAL~~

starlight to full moon. While the range capability of the SSS varied with the ambient light level, it always provided a significant advantage over any other optical observation device under identical conditions. Tests showed that the SSS would detect an individual in combat clothing in an upright position against a dark background at 325 meters when there was a half moon. The individual was clearly identifiable under these conditions and his actions could be observed.

When a NVD was used for surveillance from a fixed or semi-fixed point, and a maximum range capability desired, the CSWS was used. Targets were discernible to the rated range of the device under all light conditions equal to or exceeding a half moon and there were no recommendations that the range of the device should be increased.

Minimum range to which both devices would focus ranged from 1 to 15 meters, depending upon the operator/NVD combination. The minimum range obtainable was adequate in all instances.

3. Artificial Illumination

The SSS and CSWS are so designed that they either "cut off" (later models) or "white out" when the ambient light being amplified exceeds the capacity of the scope. Optimum resolution and ranges are obtained just before the ambient light reaches this intensity. This optimum point is roughly that intensity equivalent to conditions on a clear night with full moon.

The increase in effectiveness of the NVD up to this point is not directly proportional to the increase in ambient light and no significant advantage appeared to result from the use of artificial illumination specifically for the NVD except in conditions where ambient light was less than the equivalent of a quarter moon.

A test was conducted by the 2nd Bn, 327th Infantry, 1st Brigade, 101st Airborne Division, and B Battery, 29th Artillery Battalion (Searchlight) at Tuy Hoa on 15 February 1966 on an overcast, moonless night. They tested the effect of using a searchlight for artificial illumination to aid in using the SSS. It was found that use of the pencil or direct beam caused the SSS to blank out since the light intensity exceeded design tolerances. The "defocused" beam was then tried and was found effective when offset from the target area by no less than six mils. These conditions resulted in an ambient light level closely approximating that previously found to be optimum (unrestricted visibility, full moon). This resulted in an increase of 50 percent in range and target resolution over that experienced without artificial illumination.

~~CONFIDENTIAL~~

~~CONFIDENTIAL~~

Other types of artificial illumination such as flares also improved the effectiveness of the NVD as long as they did not exceed the maximum usable light level limit. The NVD could not be pointed directly at such sources but the devices did assist in detecting targets in the surrounding areas. The resolution provided by the NVD under these circumstances was found to be greatly superior to that provided by other sources, including the naked eye.

4. Environmental Effects

There were no adverse effects on the operation of the NVD because of the temperatures encountered. Temperatures ranged from a low of 50 degrees Fahrenheit at night to 100 degrees Fahrenheit in the day. No freezing temperatures were experienced during the test period.

Humidity is consistently over 50 percent in RVN and normally is in the 70 to 90 percent range. This humidity accented the need for constant maintenance and contributed to condensation within optical lens elements. Specific problems relating to the high humidity and frequent precipitation were water condensation within the sight housing and absorption of water by the canvas carrying case and liners in the metal shipping container.

Rain presented a specific problem with the SSS because it streaked the front objective lens and thus affected image resolution. Users recommended that the front lens be recessed in a manner similar to the CSWS.

The most significant environmental effect was the ambient light condition. As previously stated, the usable range of the NVD is dependent upon the ambient light available. Even though the effect is not directly proportional, light levels less than those equivalent to a quarter moon on a clear night will restrict the capability of the NVD. Clouds, fog, and rain directly decreased the ambient light level and significantly decreased resolution and range capabilities of NVD.

5. Magnification and Field of Vision

Magnification and field of vision are discussed together since they are directly and inversely related. The magnification of the SSS is 4x and its field of vision 171 mils, or about 10 degrees. The magnification of the CSWS is 7x and its field of view 105 mils or about 6 degrees. Both of these sets of data are meaningful only when considered in light of the ranges of the NVD.

The rated range of the SSS is 400 meters. Therefore, at maximum range, the sight will provide an observable width of 68 meters and objects therein will appear about 100 meters away. The rated range of the CSWS is 1,000 meters so it provides an observable width of 105 meters at

~~CONFIDENTIAL~~

CONFIDENTIAL

maximum range, and objects appear to be at a distance of 128 meters.

Users of both devices reported that magnification and fields of view were adequate and did not recommend increasing one at the expense of the other. If either could be increased without prejudice to the other, or increasing the weight of the device, it was recommended that the field of view be broadened.

6. Adjustments

Only two adjustments are required for operation of the NVD. These adjustments are for diopter and range. The diopter adjustment was required only once for each individual user. This setting was adjusted until the reticle became clear and distinct. Once established, this setting remained constant, and the only further adjustment necessary was for major changes in range using the range knob. No difficulties were encountered in making these adjustments.

7. Mounting and Dismounting

Very few operators had difficulty in mounting or dismounting the NVD. Of 115 operators, only 3 experienced difficulty in this area. However, there were quite a few comments that the rifle SSS telescope mount assembly should be redesigned to facilitate the re-mounting of the scope at night. During the hours of darkness when a soldier attempted to remount the scope on the weapon bracket after having used it for hand-held surveillance, he would fumble and lose time because the bracket locks had drifted closed. This prevented quick insertion of the male end of the bracket into the telescope assembly and caused unnecessary noise as well. Tapering the male and female components of the bracket and mount assembly would facilitate quicker mounting during the hours of darkness.

The offset side-mounted position made the M14 and M16 rifles unbalanced and awkward to handle, especially after prolonged use such as at an ambush site. Also, the mount is suitable only for use by a right-handed person. It was suggested that the scope be mounted in the center of both the M14 and M16 rifles, although it was recognized that the location of the chamber on the rifle would cause a design problem.

8. Reticle Illumination

When the NVD is turned on, the reticle may be used as an aiming device. The operators who used the reticle in the SSS as an aiming device estimated that the reticle remained illuminated for 1 to 5 minutes. The short estimates of periods of reticle illumination is attributed to the lack of continuous observation through the device. It was determined by test that after a 30-second charge the reticle remained illuminated for more than 30 minutes.

CONFIDENTIAL

~~CONFIDENTIAL~~

Experience factors were not determined during combat operations on the CSWS because it was not employed with the 106mm recoilless rifle or caliber .50 machinegun a sufficient number of times to develop valid data.

9. Oscillator Noise

Oscillator noise was not a tactical spoiling factor in employment of the NVD. Even though 74 of 96 operators or witnesses were able to hear it for a distance of 6 meters or less, the noise was negligible. Of these, 51 could hear it from a distance of only 3 meters or less.

10. Shortcomings

Individuals who had used this equipment reported the overall reliability of the NVD to be outstanding. The CSWS thus far has had very few components that failed, though this may be attributed to the minimum employment of this device in combat operations. Some minor shortcomings were noted in different components of the SSS.

The present canvas carrying case absorbs moisture readily and becomes an additional weight burden. The effect of this moisture was apparent on the outer components of the SSS when traces of rust appeared on some devices, but no adverse effect upon the inner sealed components of the SSS appeared. When the case dried it shrunk, thus creating excessive stress on the zippers which then became unserviceable in large numbers. The case was also too short (especially after shrinkage) for proper storage of the SSS.

Moisture seeped into the sight housing and condensed on both inside lens facings. A tighter seal was required where the objective lens assembly is seated in the bell-end of both the SSS and CSWS.

The focusing knob was frequently damaged inadvertently. The individual operator in each instance failed to release the locking lever before attempting to re-focus the scope. The operator, having focused at a given range, would lock the knob into place. On certain occasions he was required to re-focus for another range. In his haste he failed to unlock the focusing knob mechanism. By forcefully turning the knob he subsequently stripped the thread of the collet and damaged that part of the system (figure 5). ACTIV has experimented by removing the locking lever from the focusing knob and found that there is sufficient friction from the quad ring on the objective lens assembly to maintain focus adjustment during firing of the M16 rifle. However, when used with the M14 or M60 machinegun, the locking lever should be used to insure that the desired range is maintained during firing. A redesigned focusing system using a pinion and gear was suggested as a possible solution. However, the present eccentric cam has the advantage

~~CONFIDENTIAL~~

~~CONFIDENTIAL~~

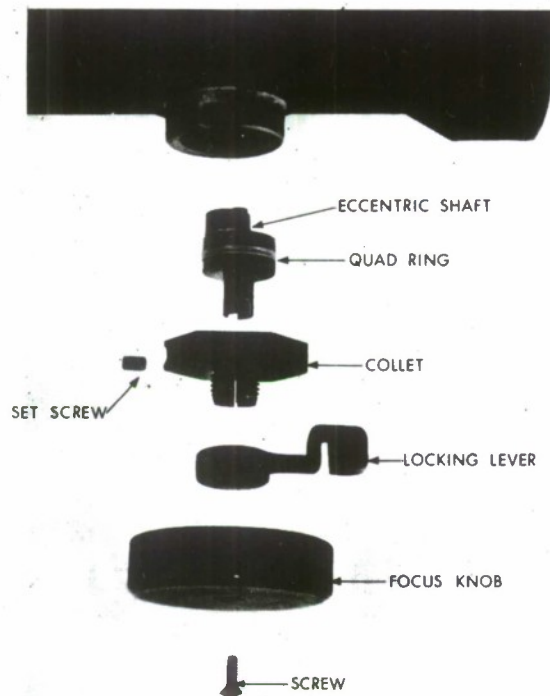

(U) FIGURE 5. Small Starlight Scope collet and locking lever for focusing knob.

of continuous focusing action. No damage through overturn can occur to the focusing knob when using this design concept.

A small number of rubber eyeshields were lost during operations because they were not snugly fitted to the eyepiece of the scope. This is an important item because it prevents the operators face from being illuminated by the glow emitted from the scope. The operator must insure that when the scope is turned off, the eyepiece is directed toward himself to conceal a momentary flash which is emitted. This flash, if directed away from the operator, could easily compromise his location.

On two occasions the image intensifier tubes were reported cracked and were sent to Sacramento Army Depot for repair. In addition, 39 of approximately 400 image tubes burned out in the SSS and 3 image tubes burned out in the CSWS during normal use.

The fragile rims of the objective lens assembly of several scopes were cracked during operations. When the SSS was transported by carrying straps or mounted on a weapon, the objective lens assembly rim occasionally became damaged by accidentally bumping it against various solid objects such as trees, rock formations, or when entering or dismounting vehicles.

~~CONFIDENTIAL~~

~~CONFIDENTIAL~~

There have been many reports received from maintenance units that indicate that the plastic objective lens cap of the SSS is frequently lost while the scope is in use. Most of the units suggested that a cap be designed so that it would be attached permanently to the scope.

The shipping container for the NVD was found to absorb moisture quite readily in the humid environment of RVN. The shipping container is also hard to dry out after it becomes damp.

11. Findings

a. The SSS and CSWS were simple and easy to operate for the average US Army combat soldier.

b. The SSS and CSWS provided the combat soldier with practical and effective instruments for night vision in battle areas which varied in range from 15 to 1800 meters.

c. Usable range depended upon terrain, vegetation, weather, and ambient light conditions.

d. Artificial light sources were found to be effective substitutes or supplements for improving a low level ambient light condition.

e. The following components and items of supporting equipment of the SSS system performed in such a manner as to require correction (See also annex C.):

- 1) Focusing knob - Easily split or broken off the shaft.
- 2) Lens cover - The lens cover was not secured to the housing and was easily lost.
- 3) Rubber eyepiece - Easily became detached from scope during operations and after continuous use in inclement weather becomes deformed.
- 4) Power switch - Easily bent or broken.
- 5) Canvas carrying case - Absorbed moisture readily and became a weight burden.
- 6) Telescope mount assembly - The locking device required a positive and silent open/close locking knob.

~~CONFIDENTIAL~~

- 7) Metal shipping container - The upper and lower liner absorbed moisture, which was a contributing factor to moisture condensation inside the sight housing.
- 8) Objective lens housing rim - Fragility of this item caused it to be easily damaged during operations.

f. There was insufficient experience with the CSWS to arrive at any findings on integral parts reliability.

C. OBJECTIVE 3 - MAINTENANCE AND LOGISTICS

This objective was established to describe and evaluate maintenance and logistic support requirements for each type of NVD being used in RVN. General areas considered were supporting maintenance facilities, maintenance evacuation procedures, and adequacy of maintenance allocation charts in available technical manuals.

The new generation of night vision devices has been employed in the field since December 1965. During the first 4 months, there were insufficient maintenance instructions available. The only guidance available was contained in Technical Manuals 5-1090-206-15 for SSS and 5-1090-208-15 for CSWS. However, in April 1966, all US Army support units were furnished coordinating and maintenance instructions for implementation of an effective maintenance and logistical support program. To date, there is an inadequate maintenance float of either end-items or major components for repair of the NVD and the effectiveness of this planned backup support cannot be fully determined.

1. Maintenance and Logistical Functions

The technical manuals accompanying each piece of equipment provided operators with detailed maintenance information. Operators were primarily responsible for the care, cleaning, and daily inspections that could be done without disassembling major components. Defective batteries and reticle lamp bulbs were the only parts authorized for replacement by the operators.

When the evaluation began, most of the defective night vision devices were deadlined at direct support unit level awaiting necessary replacement parts. Since there were no replacement parts available in Vietnam, direct support units submitted requisitions through normal channels. A few parts were received in April 1966 against requisitions submitted in December 1965. By cannibalizing some parts and by locally producing others, several defective scopes were repaired and returned to the using units. In April 1966, instructions from G4 USARV outlined correct requisitioning and evacuation procedures and provided a repair parts list which contained federal stock numbers and other necessary

CONFIDENTIAL

information to implement the program. When adequate replacement parts were on hand, the bulk of the maintenance on the night vision devices could be handled by the direct support units. Until the planned maintenance support program becomes operational, defective devices requiring a higher echelon level of repair or replacement parts not otherwise on hand, will be evacuated directly to the Sacramento Army Depot by direct support units.

When operational requirements have been satisfied through initial issue, a maintenance float will be developed at the following general support units:

- a) 54th Signal Company (FS&M), Saigon, Vietnam.
- b) 56th Signal Company (FS&M), Qui Nhon, Vietnam.
- c) 128th Signal Depot Company, Cam Ranh Bay, Vietnam.

2. Maintenance Publications and Guides

The maintenance allocation charts published in Technical Manuals 11-1090-269-15 and 11-1090-268-15 adequately defined responsibilities for each echelon of maintenance and the Basic Issue Items List in the Technical Manuals was adequate. However, all items listed on the Basic Issue Items List did not reflect the Federal Stock Number. The guidelines set forth in the instructions from G4 USARV was determined to be sufficient to implement an effective support program.

3. Maintenance Shop Conditions

There was no need to establish special environmental conditions (i.e., "clean rooms," controlled humidity, or air conditioning) for the performance of maintenance on the Night Vision Devices. There were no adverse effects determined from the lack of any such special conditions.

4. Findings

- a. The maintenance authorized to be done by operators was accomplished without unusual problems.
- b. The lack of replacements for major components of the NVD in Vietnam has necessitated the direct evacuation of defective devices from direct support units to the Sacramento Army Depot.
- c. Cannibalization and local production of certain minor parts enabled direct support units to repair a limited number of defective night vision devices and return them promptly to the using units.

CONFIDENTIAL

~~CONFIDENTIAL~~

d. General support units did not have the necessary replacement parts to participate in the maintenance and logistical program at the start of the evaluation.

e. Direct support and general support units were requisitioning all the repair parts they were authorized to have on hand and they used the special requisitioning procedures, involving "Project Code ZLM", set up for the night vision devices.

f. Maintenance allocation charts were adequate.

g. The basic issue items listed in the manuals were determined to be adequate.

h. There were no adverse effects determined from the lack of controlled environmental conditions in areas where maintenance was performed.

D. OBJECTIVE 4 - BASIS OF ISSUE

This objective was established to determine the suitability of the Department of the Army Basis of Issue (hereafter referred to as DA BOI) for each type of NVD evaluated.

The current DA recommended BOI is as follows:

- 1) Starlight Scope, Small, Hand-Held or Individual Weapons Mounted
 - a) Two per infantry squad (infantry and mechanized units)
 - b) One per selected individual habitually in forward area - e.g. reconnaissance and scout personnel (all units).
 - c) One per engineer squad.
- 2) Crew-Served Weapon Night Vision Sight
 - a) One per tracked vehicle operating in forward area (including tanks) (all units)
 - b) One per 106mm recoilless rifle (infantry and mechanized units)

User reaction to the NVD under combat conditions, its gross weight, and means of transportation were taken into consideration along with the tactical and logistical aspects to determine the suitability of the DA BOI.

~~CONFIDENTIAL~~

CONFIDENTIAL

1. Distribution

The Department of the Army shipped a packet of 60 SSS and 8 CSWS to each of the 4 major US ground combat units then in South Vietnam.

It was planned that each packet would be used by one selected battalion which would participate in the evaluation as the test unit of its major organization. The remaining battalions of the major organizations would receive packets as they became available.

The 1st Infantry Division, 173rd Airborne Brigade, and the 1st Brigade, 101st Airborne Division, for reasons of tactical expediency, distributed their battalion packets prorata among all their subordinate infantry units instead of supplying a single battalion as originally stipulated. As a result, these units had only four starlight scopes and one CSWS in each company.

The only unit to follow plans was the 1st Cavalry Division (Airmobile). This organization issued the packet intact to one battalion for approximately 60 days. Afterward, the division G3 concluded that this one battalion packet should be redistributed among as many units as possible to get maximum performance from the NVD. The reallocation configuration was as follows: 14 SSS and 2 CSWS to each of 4 battalions, (1/5 Cavalry, 2/5 Cavalry, 2/12 Cavalry, and 1/9 Cavalry), and the remaining 4 SSS to the 1/12 Cavalry.

Each of the units evaluated received some additional NVD. However, none of the units had a complete packet as would have been allocated to them according to the DA BOI. Considerably more NVD could have been used by each unit. For instance, the majority of the units had only one or two SSS per platoon.

If a patrol were sent out and took one SSS with it, only one scope remained to cover the platoon's base defensive sector. It was the consensus of all concerned that this was an insufficient number and, that even if the quantities of scopes recommended by the DA BOI were available, they would meet only the minimum needs of the units. In most of the units, all of the available operational NVD were being used every night in either an offensive or defensive capacity.

As described in objectives one and two, the NVD was found to be an asset to the soldier in night operations. Taking into consideration the inherent limitations of weather, terrain, and vegetation, the various uses of the NVD in combat were dependent in the final analysis only upon the imagination of the user or his unit commander. The simplicity of maintenance and operation required little formal training of operators. The few minor deficiencies that were determined during

CONFIDENTIAL

CONFIDENTIAL

the evaluation had no serious effect on its use by the units.

There were various comments concerning the effect of the weight of the NVD and, although some individuals complained it was too heavy, the majority of sources contacted by ACTIV agreed there should be one SSS in each squad. Troops were also of the opinion that more scopes than the number proposed would restrict the amount of other gear and ammunition that could be carried by the squad. The majority of interviewees felt that a little improvement in the carrying case would provide them with a safe, dependable, and easy means of transporting the NVD.

2. Changes

The changes below in the DA BOI have been suggested by the majority of the personnel interviewed during the evaluation.

The present DA BOI provides two SSS per rifle squad and none for the weapons squad of the rifle companies. It was suggested that the six SSS allotted to the rifle platoon remain the same but that they be distributed differently, as follows: one per rifle squad and M60 machinegun for a total of five, and one to be retained in the platoon headquarters for use by the platoon leader at his discretion. In this configuration, the total number of 54 in the infantry battalion would remain the same. The DA BOI of SSS to the headquarters company reconnaissance platoon of the infantry battalion, headquarters company scout element of the airborne infantry battalion, and combat support company scout element of the airmobile infantry battalion was determined to be satisfactory.

The only change suggested in regard to the CSWS was to provide a device for each caliber .50 machinegun in addition to those used on the 106mm recoilless rifle. It was generally conceded that should the requirements for these weapons be increased, it would be better to have the CSWS on hand. Insufficient data are available to determine if there is a requirement for one CSWS to be issued per tracked vehicle operating in forward areas.

In addition, according to Training Text 23-151, November 1965, entitled "Crew-Served Weapons Night Vision Sight", a tripod is available for independent use of the CSWS. If these tripods were included with the CSWS as a basic issue item, the CSWS could be used effectively as surveillance devices at static or semi-static defensive positions.

3. Findings

a. The proposed DA BOI was valid for distribution of the SSS except that the internal distribution of devices at the infantry company

CONFIDENTIAL

~~CONFIDENTIAL~~

level required adjustment as follows:

- 1) One SSS per rifle squad
- 2) One SSS per M60 machinegun (weapons squad)
- 3) One SSS per platoon headquarters

b. Although limited experience was gained in the distribution of CSWS within units, the proposed DA BOI of this item appears valid except for the allocation of one per tracked vehicle in forward areas.

~~CONFIDENTIAL~~

~~CONFIDENTIAL~~

III. (C) CONCLUSIONS AND RECOMMENDATIONS

A. CONCLUSIONS

It is concluded that:

1. The SSS and the CSWS increase the ability of the individual soldier to accomplish night combat surveillance and enable him to direct aimed weapons fire during night operations conducted under the equivalent of a quarter moon or better illumination.

2. Usable range and target definition provided by night vision devices is dependent upon terrain, vegetation, and atmospheric conditions existing at the time combat operations are conducted.

3. Artificial light sources are supplements to the NVD during periods of low natural illumination.

4. The NVD can withstand the rugged environmental conditions in RVN. Certain minor components of the SSS, however, are easily damaged or have shortcomings that need correction.

5. The reliability of the components of the CSWS could not be assessed due to its infrequent use.

6. The SSS and CSWS are effective in night defensive operations, ambushes, and reconnaissance patrols.

7. The SSS and CSWS are suitable for night-time adjustment of direct and indirect fires including mortar and artillery.

8. The SSS and CSWS can be used without formal individual training.

9. During the data collection period the lack of replacement parts for the NVD caused delay in getting defective devices repaired and returned promptly to using units.

10. The instruction from G4, USARV to all units involved in maintenance and logistical support for the NVD contains adequate information for implementation of an effective maintenance and logistical support program.

11. The Basic Issue Items Lists in the technical manuals covering the NVD evaluated are satisfactory.

12. At the close of the data collection period a maintenance float had not been established at general support unit level.

~~CONFIDENTIAL~~

CONFIDENTIAL

13. The proposed DA BOI provides the minimum essential number of NVD for offensive and defensive operations. However, a distribution of one SSS per rifle squad, M60 machinegun, and platoon headquarters would enable the using unit to more effectively employ the NVD. There are insufficient data available to validate the allocation of one CSWS per tracked vehicle in forward areas.

14. The most effective utilization of the CSWS was when it was mounted on a tripod.

B. RECOMMENDATIONS

It is recommended that:

1. The production of SSS and CSWS presently under contract be expedited for earliest delivery to US combat troops in RVN.
2. Shortcomings noted in objective 2 findings be corrected immediately.
3. The DA BOI be amended to provide one SSS per rifle squad, one SSS per M60 machinegun, one SSS per infantry platoon headquarters.
4. The maintenance float of end-items and major components be developed concurrently at general support level with the issue of end-items to combat units. That a minimum of 10 percent per delivered quantity be considered as the required support float level.
5. The DA publications concerning the characteristics and performance of NVD be up-dated in accordance with the findings and conclusions of this report.
6. Doctrine for the employment of the SSS and CSWS, including programs of instruction for employment and maintenance under counterinsurgency and conventional combat conditions, be developed by the appropriate agency.
7. The tripod designed for use with the CSWS be issued with this NVD.
8. The Mechanized Armored Combat Operations in Vietnam (MACOV) evaluation determine requirements for night vision devices in mechanized and armored units employed in Vietnam.

CONFIDENTIAL

~~CONFIDENTIAL~~

(c) ANNEX A

DETAILED DESCRIPTION OF MATERIEL

The Starlight Scope, Small Hand-Held or Individual Weapons Mounted and the Crew-Served Weapon Sight are battery powered, electro-optical devices for night visual observation. These devices may be used as surveillance devices or to place aimed fire of weapons at night under ambient skylight conditions (i.e., moonlight, starlight, or artificial light). These devices are two of the newest members of the family of night vision devices and they possess distinct advantages over their predecessors. The primary advantage of these devices is that they do not project visible or infrared light. They are also lighter, more durable, have a sharper image, excellent adaptability to weapons, and simplicity of operation and maintenance. They also render greater range usage under most light conditions.

The NVD sight assembly consists of the following basic components: the main housing, the objective lens assembly, focusing knobs and locking lever, sight reticle with elevation and azimuth knobs, internal high voltage power supply with three-way toggle control switch (rotary control switch for the CSWS) eyepiece assembly with rubber eyeshield and focusing ring, telescope mount assembly, and image intensifier tube. The Crew-Served Weapon Sight provides a different eyepiece and boresight assembly for the larger weapons. The right-angle eyepiece is used with the 106mm Recoilless Rifle, M40A1; an in-line eyepiece is used when the sight is mounted on the Browning machinegun, caliber .50, M2HB.

The main housing is a machined casting which contains all the components and sub-assemblies of the sight system. The main housing possesses a basic tubular configuration. The upper part of the main housing accommodates the high voltage power system. The rear of the main housing is threaded to receive the eyepiece retainer ring. The objective lens focusing knob is mounted on the forward left side of the housing while the objective lens assembly was designed to be contained in the bell-shaped area at the front of the main housing. The two pads for mounting of the telescope assembly are located underneath and centered on the housing and the three-way power control toggle switch is centered on the left side of the main housing. (Figures A-1 and A-2 illustrate the external view of the SSS and CSWS.)

The objective lens assembly consists of an objective lens cell and four single glass elements. The glass elements are contained within the objective lens by three spacers and a retainer. (See figures A-3 and A-4.)

A-1

ANNEX A

~~CONFIDENTIAL~~

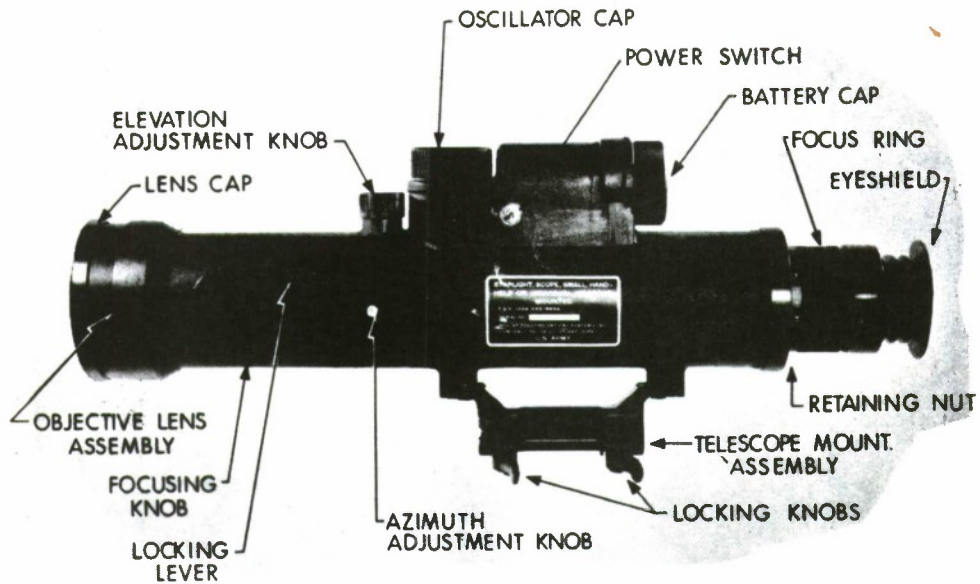

(C) FIGURE A-1. Small Starlight Scope, external view.

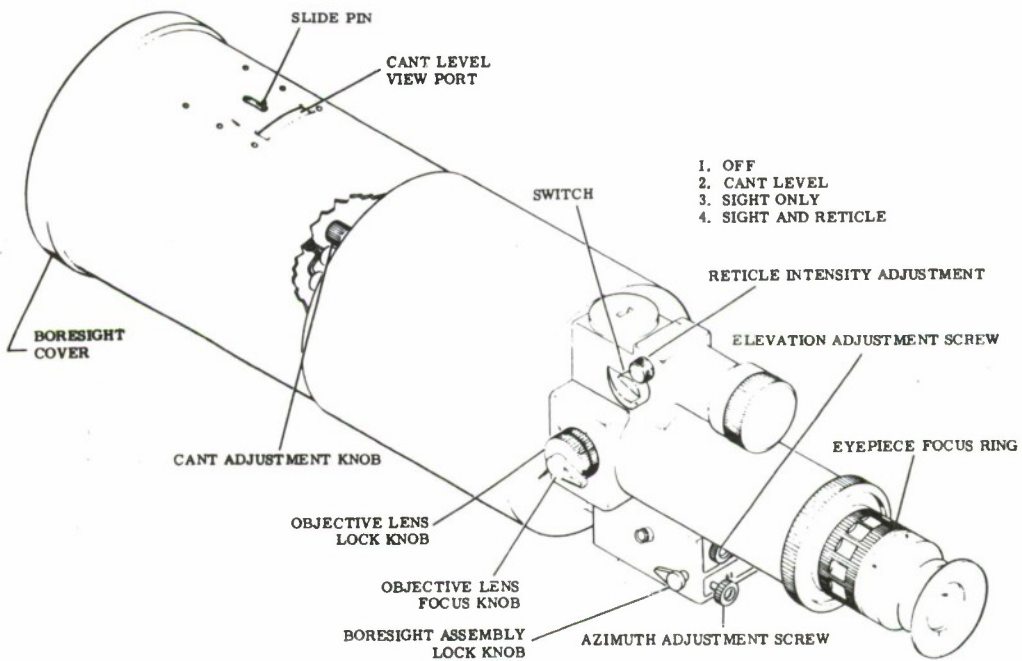

(C) FIGURE A-2. Crew-Served Night Vision Sight, external view.

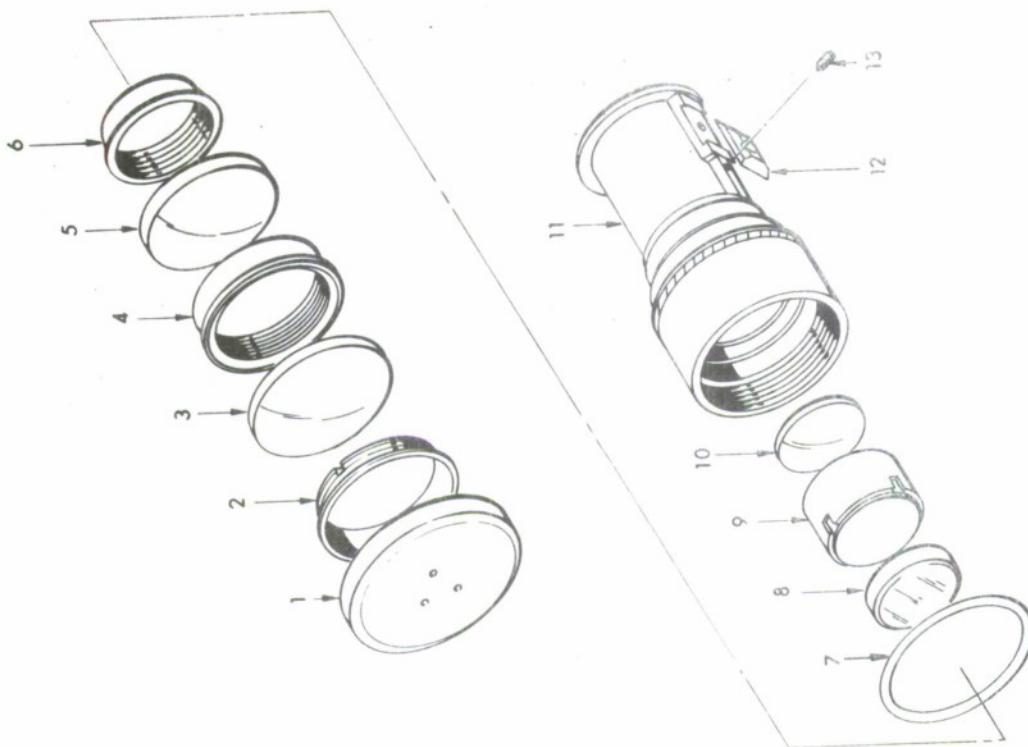

FUNCTIONAL GROUP

- 6703
- 6702
- 6702
- 6702
- 6702
- 6702
- 6702
- 6703
- 6702
- 6702
- 6702
- 6702
- 6703
- 6702

ITEM NAME

- LENS CAP
- CELL RETAINER
- 1ST ELEMENT, OBJ
- 1ST AND 2ND SPACER
- 2ND ELEMENT, OBJ
- 2ND AND 3RD SPACER
- QUAD RING
- 3RD ELEMENT, OBJ
- 3RD AND 4TH SPACER
- 4TH ELEMENT, OBJ
- OBJECTIVE LENS CELL SLIDE
- PURGE VALVE

ITEM

- 1
- 2
- 3
- 4
- 5
- 6
- 7
- 8
- 9
- 10
- 11
- 12
- 13

(C) FIGURE A-3. Small Starlight Scope, objective lens assembly.

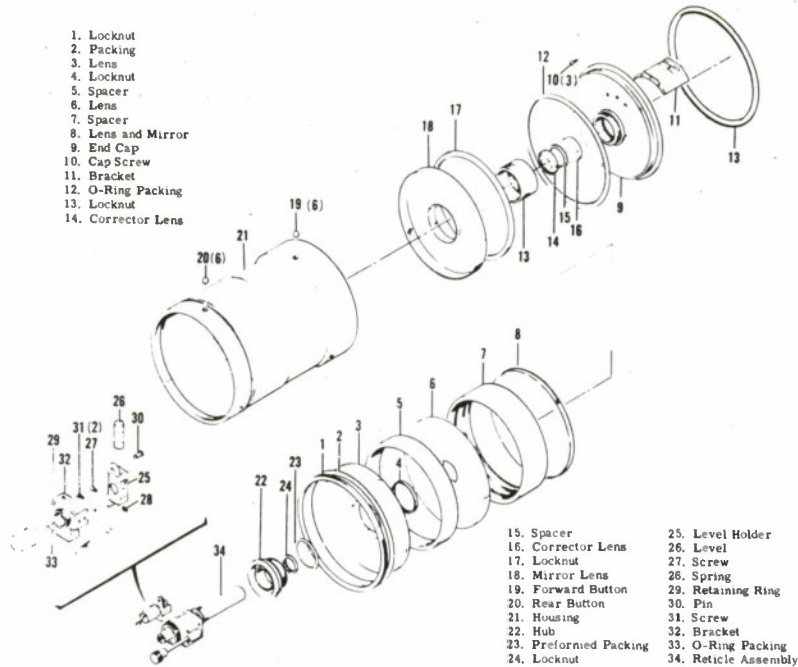

(C) FIGURE A-4. Crew-Served Night Vision Sight, objective lens assembly.

The focusing knob and locking lever permit movement of the objective lens assembly within the main housing for range focusing. For viewing near objects, the objective lens is moved forward in the main housing and for viewing distant objects it is moved back into the main housing. The locking lever provides a means of locking the objective lens assembly in the desired focal position. When the NVD is weapon-mounted, the locking lever aids in maintaining the established focal position during the shock of weapon firing. However, it is not necessary to use the locking lever when the SSS is used as a hand-held surveillance device. Locking is accomplished by rotating the locking nut counter-clockwise until it stops.

The sight reticle is located within the main housing just forward of the image intensifier tube. The reticle can be adjusted for elevation and azimuth by rotating the knurled elevation and azimuth adjustment knobs of the SSS. For the Crew-Served Weapon Sight, the boresight elevation knob adjusts the reticle to accomplish boresighting. The reticle pattern of the SSS displayed on the input cathode of the image intensifier tube has an inverted "T" type configuration consisting of three phosphorescent dots on the stem of the "T" and five dots displayed at the top of the "T". (See figure A-5.)

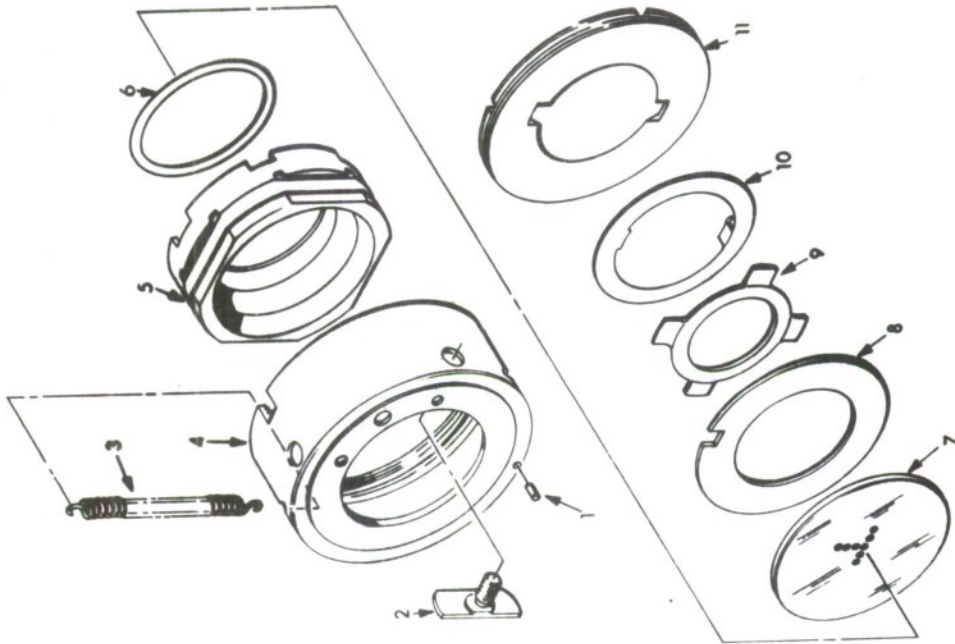

FUNCTIONAL GROUP

- 6702
- 6702
- 6702
- 6702
- 6702
- 6702
- 6702
- 6702
- 6702
- 6702
- 6702

ITEM NAME

- KEY (DOWEL PIN)
- RETICLE PUSHER (2)
- RETICLE SPRING
- RETICLE HOUSING
- RETICLE HOLDER
- O-RING
- RETICLE
- RETICLE SPACER
- RETICLE SHIM
- IMAGE TUBE GROUND
- RETICLE RETAINER

ITEM

- 1
- 2
- 3
- 4
- 5
- 6
- 7
- 8
- 9
- 10
- 11

(C) FIGURE A-5. Small Starlight Scept, reticle pattern (7), and assembly.

~~CONFIDENTIAL~~

The reticle pattern of the CSWS is displayed also on the input cathode of the image intensifier tube and is composed of 22 dots. The dots are arranged in three parallel vertical rows of six, seven, and six dots, with the remaining three dots on the stem. (See figure A-6.) During periods of high ambient light level the reticle pattern is clearly defined in the scope. When the ambient light level decreases, the dots of the reticle may be charged electrically to view them better. The procedure for charging the reticle of the SSS is to depress the 3-way toggle switch and hold it down for 3 to 5 seconds. This action illuminates the reticle lamp which shines on the phosphorescent dots of the reticle and causes them to glow.

The SSS and CSWS power supply systems consist of a 6.75 volt mercury battery, a high voltage oscillator, and a toggle switch (rotary control-switch on CSWS). One battery is used for the operation of the sight assembly. The battery is installed by removing the battery cap and inserting the battery, positive (plus) end first, into the power housing. The oscillator mounts directly on the top forward portion of the image intensifier tube and an electrical connection is made at this point. (See figure A-7.) On the upper side of the oscillator is a 6.75 volt input connector. An oscillator contact assembly is placed over the oscillator and provides the 6.75 input voltage to the oscillator. The oscillator and image intensifier tube are grounded by means of a grounding spring. The oscillator is held in place by a knurled cap which is identical to and interchangeable with the battery cap. A 3-position toggle switch provides for sight "off", sight "on", and sight "charging" positions. The middle position is sight "off". The upper position of the switch is sight "on" and the lower position of the switch permits charging of the reticle to compensate for low light level conditions. The rotary control switch of the CSWS provides for sight "off", cant level, sight "only", and sight and reticle. This knob is operated by turning in a clockwise manner and has a "click" stop for each position.

The eyepiece assembly (figures A-8, A-9, and A-10) mates into the rear of the main housing and is held in position by the eyepiece retaining nut. The eyepiece consists of six glass elements (two doublets, a singlet, and a window). One of the doublets and the singlet glass element are capable of forward and rearward movement by means of the eyepiece focus ring. This movement enables the operator to select his own diopter setting. The eyepiece focusing ring contains diopter markings for future reference. Attached to the eyepiece assembly is a rubber eyeshield which protects the eye from injury when the SSS is mounted on a weapon and aids security by preventing the visible glow emitted from the rear of the scope from illuminating the operator's face. The eyeshield may be removed by slipping it off. A secure eyeshield is provided for use with the newer series of SSS.

~~CONFIDENTIAL~~

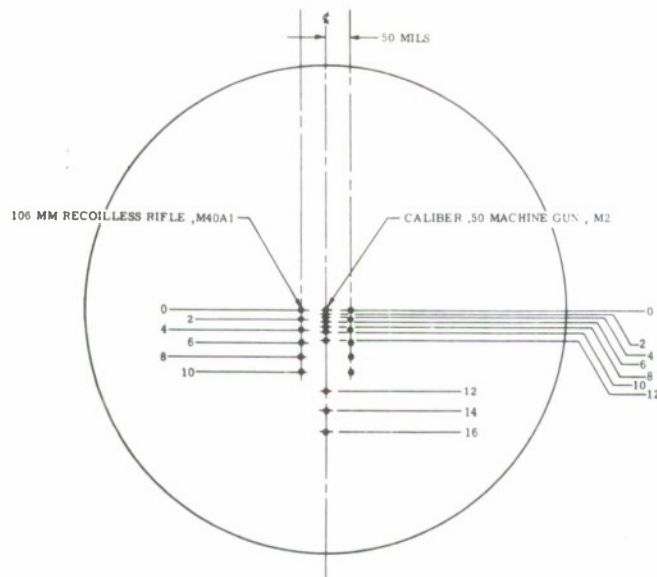

(U) FIGURE A-6. Crew-Served Weapon Night Vision Sight, reticle pattern.

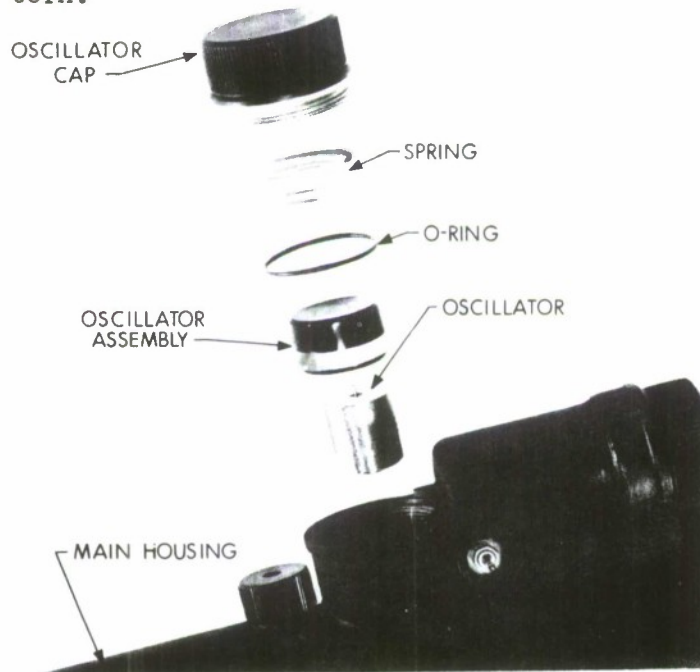

(U) FIGURE A-7. Small Starlight Scope, oscillator.

ITEM	ITEM NAME	FUNCTIONAL GROUP
1	INSULATOR	6702
2	PACKING (O-RING)	6702
3	LENS CELL ASSEMBLY	6702
4	NUT (RETAINER)	6702
5	2nd ELEMENT	6702
6	1st ELEMENT	6702
7	GASKET	6702
8	PACKING (O-RING)	6702
9	MAIN BODY	6702
10	WASHER	6702
11	PACKING (QUAD RING)	6702
12	FOCUS RING	6702
13	PACKING (QUAD RING)	6702 </td
14	WASHER	6702
15	NUT	6702
16	EYESHIELD	6702
17	DRIVE STUD	6702

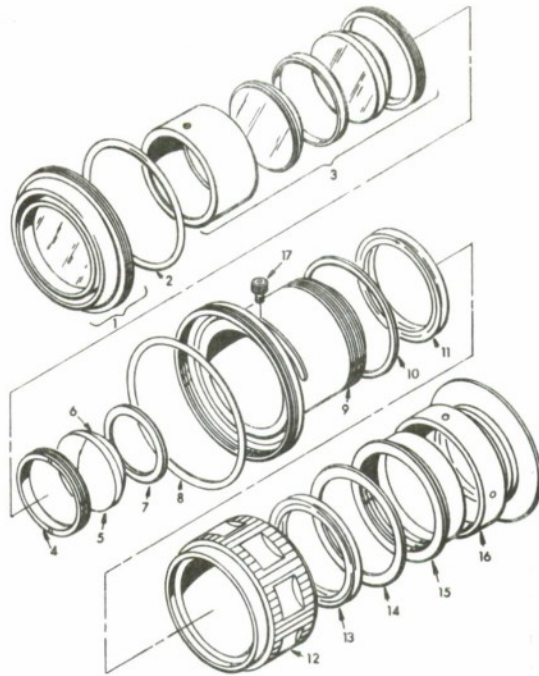

(U) FIGURE A-8. Small Starlight Scope, eyepiece assembly.

- | | |
|--------------------|---------------------|
| 1. Eyepiece Cap | 13. Cap Screw |
| 2. Insulator | 14. Washer |
| 3. Packing | 15. Prism Spacer |
| 4. Retainer Ring | 16. Shock Spacer |
| 5. Retaining Ring | 17. Cap Screw |
| 6. Element | 18. Lock Washer |
| 7. Element | 19. Bracket and Pad |
| 8. Spacer | 20. Prism |
| 9. Element | 21. Screw |
| 10. O-ring Packing | 22. Cover |
| 11. Retaining Ring | 23. Gasket |
| 12. Gasket | 24. Window |
| | 25. Housing |

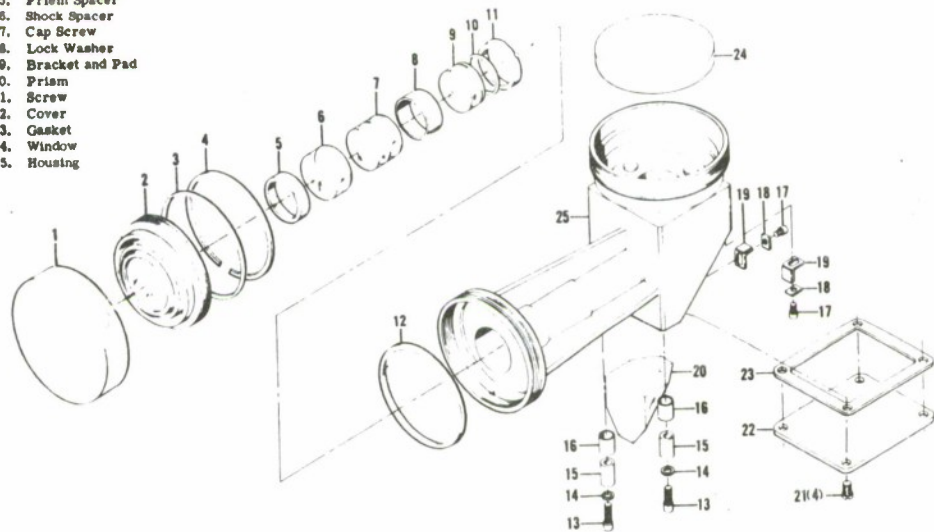

(U) FIGURE A-9. Crew-Served Night Vision Sight, right-angle eyepiece assembly.

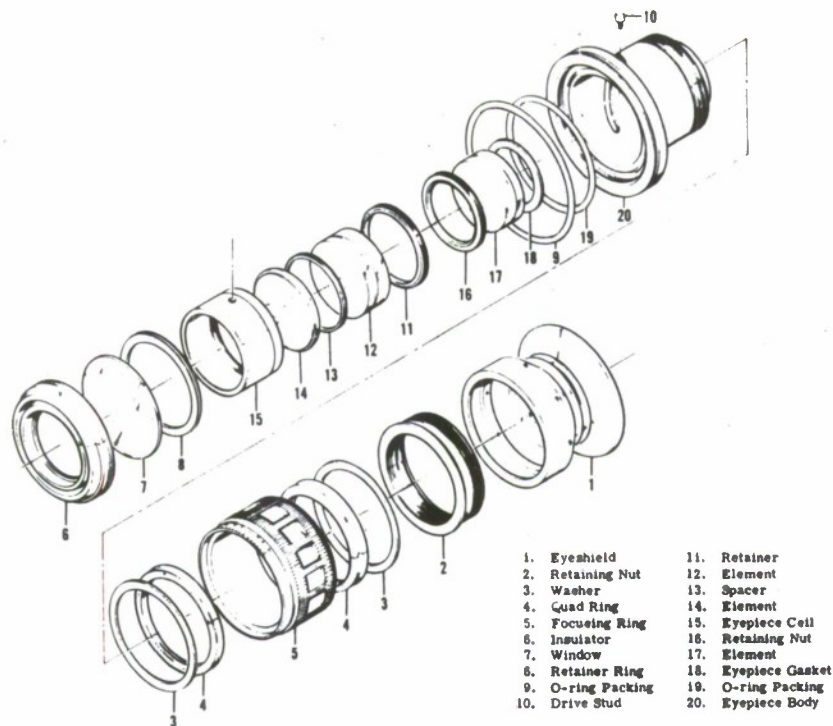

(U) FIGURE A-10. Crew-Served Night Vision Sight, in-line eyepiece assembly.

The secure eyeshield has a flap which must be pulled aside before the operator can see through the instrument. When the operator discontinues his viewing through the SSS the flap returns to its original position and is fastened by means of two magnets to prevent light from escaping through the rear of the eyepiece.

When the weapon adapter bracket is mounted on the weapon, the SSS is placed in position by sliding the mount assembly on to the weapon adapter bracket. The scope is locked into place on the weapon by means of the locking knobs. The CSWS slides into a dovetail slot on the adapter assembly (the bracket) for each weapon. A clamp on the CSWS fits into a small notch on the mounting bracket and is secured to the weapon by tightening the locking nut. When the initial issue of CSWS arrived in RVN, the mounting adapter brackets for 106mm recoilless rifle were not included.

THIS PAGE NOT USED

(U) ANNEX B

EMPLOYMENT STATISTICS

Offensive Use	Number of Individuals Interviewed			
	TOTAL	1stINF	1stCAV	101st 173rd
1. Maintain direction and control of troops during movement (Patrolling).	21 (16.5%)	2 (6.7%)	8 (21%)	9 (29.7%) 2 (6.6%)
2. Provide other squad weapons with a means of delivering accurate aimed fire.	30 (23.6%)	6 (20%)	6 (16%)	7 (23.1%) 11 (36.7%)
3. Select targets for supporting weapons, including mortars and artillery, and aid in the adjustment of fires.	36 (12.6%)	5 (16.6%)	5 (13.5%)	21 (3.3%) 5 (16.6%)
4. Speed up the advance of patrolling troops	11 (8.6%)	5 (16.6%)	0	4 (13.2%) 2 (6.7%)
5. Improve efficiency in embarking, crossing, debarking and control during river crossings and other amphibious operations.	11 (8.6%)	1 (3.3%)	2 (5.4%)	8 (26.4%) 0
6. In ambushes	76 (59.8%)	21 (70%)	16 (43%)	17 (56.1%) 22 (73.3%)
7. In pursuit	3 (2.3%)	1 (3.3%)	1 (2.7%)	1 (3.3%) 0
8. In probing actions.	16 (12.6%)	2 (6.7%)	7 (18.8%)	6 (19.8%) 1 (3.3%)
9. In dismounted movement.	16 (12.6%)	3 (10%)	3 (8.1%)	8 (26.4%) 2 (6.6%)

Offensive Use	TOTAL	Number of Individuals Interviewed			
		1stINF	1stCAV	101st	173rd
10. In mounted convoy.	1 (0.7%)	0	0	1 (3.3%)	0
11. In security of rear areas and flanks.	67 (52.6%)	11 (36.7%)	23 (62%)	14 (46.2%)	19 (63.3%)
12. As a signalling device.	1 (0.7%)	0	0	1 (3.3%)	0
13. Promote confidence in troops.	60 (46.4%)	16 (53.3%)	21 (56.7%)	9 (29.7%)	14 (46.7%)
14. Contribute to security and provide added surveillance capability during night movement (reconnaissance and security patrols).	54 (42.5%)	12 (40%)	19 (51%)	15 (50%)	8 (26.7%)

Defensive Use	Number of Individuals Interviewed			
	TOTAL	1stINF	1stCAV	101st 173rd
1. Make possible the early detection and identification of enemy night movement.	118 (92.9%)	28 (93.4%)	32 (86%)	30 (100%)
2. Promote confidence in troops holding defensive positions by providing them with a capability to see at night.	90 (70.8%)	25 (83.3%)	25 (67.5%)	19 (62.7%)
3. Identify friendly patrols and aid in their passage of lines by observation and/or signalling.	56 (44.1%)	14 (46.7%)	12 (32.4%)	16 (52.9%)
4. Select targets for direct and indirect fire weapons and aid in the adjustment of fires.	39 (30.8%)	14 (46.7%)	10 (27%)	5 (16.5%)
5. Secure rear areas and flanks.	69 (54.3%)	12 (40%)	23 (62%)	21 (69.3%)
6. Locate snipers.	53 (41.7%)	15 (50%)	15 (40%)	8 (26.4%)

NOTE: There is a correlation between items 6, 11, 13, & 14 (offensive employment) items 1, 2, 3, 4, & 5, (defensive employment).

THIS PAGE NOT USED

(U) ANNEX C

MAINTENANCE SITUATION AS OF 3 MAY 1966

UNIT EVALUATED	TOTAL DEVICES		TOTAL DEFECTIVE		MAJOR DAMAGE TO DEVICES	SSS*	CSWS
	SSS	CSWS	SSS	CSWS			
1st Brigade, 101st Abn Div	120	16	9	0	DEFECTIVE IMAGE TUBES	9	0
173rd Abn Brigade	60	8	12	0	DEFECTIVE IMAGE TUBES BROKEN FOCUSING KNOBS MISSING OBJECTIVE LENS COVERS BROKEN OBJECTIVE LENS COVERS CHIPPED OBJECTIVE LENS HOUSING MISSING EYESHIELDS BENT POWER SWITCHES	3 12 5 3 5 2 1	0 0 0 0 0 0 0
1st Cavalry Division (Airmobile)	195	24	22	0	DEFECTIVE IMAGE TUBES DEFECTIVE OBJECTIVE LENS DEFECTIVE OSCILLATORS BROKEN FOCUSING SLIDES BROKEN OR MISSING LENS COVERS BROKEN FOCUSING KNOBS DEFECTIVE OR MISSING EYESHIELDS	15 11 8 3 3 3 1	0 0 0 0 0 0 0
1st Infantry Division	248	24	13	3	DEFECTIVE IMAGE TUBES BROKEN FOCUSING KNOBS BROKEN POWER SWITCHES DEFECTIVE RETICLE ASSEMBLY BROKEN OR MISSING LENS COVER ELECTRICAL SHORT IN BATTERY COMPARTMENT DEFECTIVE EYEPIECES DEFECTIVE OSCILLATORS DEFECTIVE EYESHIELDS BROKEN ZIPPERS ON CANVAS CARRYING CASE DEFECTIVE OBJECTIVE LENS	13 10 1 1 5 1 4 6 1 3 6	2 0 0 1 0 0 0 0 0 0 0
TOTAL	623	72	56	3			

*Some devices had more than one defect.

THIS PAGE NOT USED

(U) ANNEX D

DISTRIBUTION

Department of Defense

Director of Defense Research and Engineering, Department of Defense	1
Advanced Research Projects Agency, Office of the Secretary of Defense	1
Chief, ARPA R&D Field Unit, Vietnam	2
Chief, ARPA R&D Field Unit, Thailand	1
Defense Documentation Center	20

Joint Chiefs of Staff

Chairman, Joint Chiefs of Staff, ATTN: Special Asst for Counterinsurgency and Special Activities, Department of Defense	1
---	---

Unified and Joint Commands, MAAGS, and Missions

Commander, US Military Assistance Command, Vietnam, ATTN: J-3	2
Chief, Joint US Military Advisory Group to Thailand	1
Commander-in-Chief US Southern Command	1

Embassy

OAS, US Embassy, Saigon, ATTN: Mr. W. T. Field	2
--	---

United States Army

Chief of Staff, Department of the Army	1
Office of the Chief of Staff, Department of the Army, ATTN: Special Assistant for Special Warfare Activities	1
Deputy Chief of Staff for Logistics, Department of the Army	2
Deputy Chief of Staff for Military Operations Department of the Army	5
Assistant Chief of Staff for Intelligence Department of the Army, ATTN: Director of Surveillance and Reconnaissance, Doctrine Division	2
Assistant Chief of Staff for Force Development, Department of the Army	10
Office of the Assistant Chief of Staff for Force Development, Department of the Army, ATTN: ACTIV Liaison Officer	10

Chief of Research and Development, Department of the Army, ATTN:Special Warfare Division	3
Chief of Research and Development, Department of the Army, ATTN:Director of Army Research	1
Chief of Research and Development, Department of the Army, ATTN:Director of Developments	1
Office of the Chief of Communications - Electronics, Department of the Army	4
Commanding General, US Army Materiel Command	45
Commanding General, US Army Materiel Command ATTN: Director of Research and Development (AMC RD)	5
Commanding General, US Army Materiel Command, ATTN: Project Manager, Special Warfare (AMCPM-SW)	5
Commanding General, US Army Mobility Command	2
Commanding General, US Army Tank and Automotive Command	2
Commanding General, US Army Weapons Command	2
Commanding General, US Army Electronics Command	1
Commander, US Army Tropic Test Center	1
Office of Personnel Operations, Department of the Army	2
Commanding General, US Continental Army Command	30
Commander-in-Chief, US Army Pacific	5
Commanding General, US Army Combat Developments Command ATTN: CDCRE-T	70
Commanding General, US Army Combat Developments Command Experimentation Center	3
Commandant, Armed Forces Staff College	1
Commandant, Command and General Staff College	2
Commandant, US Army War College	2
Commandant, The Infantry School, ATTN: AJIIS-A	3
Commandant, The Armor School	2
Commandant, US Army Artillery and Missile School	2
Commanding General, US Army Engineer School	5
Commanding General, US Army Special Warfare School	2
Commanding General, US Army Civil Affairs School	1
Commandant, Signal School, US Army Signal Center	4
Commanding General, US Army Electronics Proving Ground	4
Commanding General, US Army Aviation Center	5
Commanding General, US Army Forces Southern Command ATTN: SCARCD	3
Commanding Officer, US Army Limited War Laboratory	2
Commanding General, US Army, Vietnam, ATTN AVHGC	20
Commanding Officer, US Army 5th Special Forces Group, Vietnam	10
Commanding General, USARPUR, ATTN: G-3	1
Commanding General, Seventh US Army, ATTN: G-3	1
Commanding General, US Army Test & Evaluation Command	2
Commanding General, US Army Ordnance Center & School	1
Commanding General, John F. Kennedy Center for Special Warfare	1
President, US Army Armor Board	1

President, US Army Infantry Board	2
President, US Army Aviation Test Board	2
Commanding General, 18th Airborne Corps	2
Commanding Officer, 1st SFG	2
Commanding Officer, 8th SFG	2
Commanding Officer, 10th SFG	2
Commanding Officer, 1st Psychological Warfare Battalion (R&L)	1
Commanding Officer, 5th Psychological Warfare Co (Field Army)	
Germany	1
Commanding Officer, 13th Psychological Warfare Battalion (R&L)	1
Commanding Officer, USAB&VPAC	1
Senior US Advisor, each ARVN corps	2
Senior US Advisor, each ARVN division	1
Commanding General, I Field Force Vietnam	5
Commanding General, II Field Force Vietnam	5
Commanding General, 173d Brigade	5
Commanding General, 1st Infantry Division	5
Commanding General, 25th Infantry Division	5
Commanding General, 1st Logistical Command	15
Commanding General, 1st Aviation Brigade	5
Commanding General, 1st Brigade, 101st Airborne Division	5
Commanding General, 1st Cavalry Division (Airmobile)	5
Commanding General, 18th Engineer Brigade	5
Commanding General, 4th Infantry Division	5
Commanding General, 196th Light Infantry Brigade	5
Commanding Officer, 11th Armd Cav Regt.	3

United States Navy

Chief, Navy Research and Development Unit	2
---	---

United States Marine Corps

Commandant, US Marine Corps	1
Deputy Chief of Staff (R&D), Hq, US Marine Corps	1
Assistant Chief of Staff G-3, Hq, US Marine Corps	1
Director, Marine Corps Landing Forces Development Center	1
Commanding General, III Marine Amphibious Force, ATTN: ACofS, G-3	5

United States Air Force

Air Force Test Unit, Vietnam	2
------------------------------	---

ACTIV-GCD	10
ACTIV Library	20

THIS PAGE NOT USED

DOCUMENT CONTROL DATA - R&D

(Security classification of title, body of abstract and indexing annotation must be entered when the overall report is classified)

1 ORIGINATING ACTIVITY (Corporate author) ARMY CONCEPT TEAM IN VIETNAM APO SAN FRANCISCO 96243		2a REPORT SECURITY CLASSIFICATION CONFIDENTIAL	
		2b GROUP GROUP 4	
3 REPORT TITLE USE OF NIGHT VISION DEVICES BY US ARMY UNITS IN VIETNAM (U)			
4 DESCRIPTIVE NOTES (Type of report and inclusive dates) FINAL REPORT-- 6 March to 16 May 1966			
5 AUTHOR(S) (Last name, first name, initial) KENNEDY, JAMES D. LTC, Arty HAYES, JOHN L. LTC, Armor JONES, ED E. JR MAJ, Sig C			
6 REPORT DATE 30 November 1966		7a TOTAL NO OF PAGES 48	7b NO OF REFS NONE
8a CONTRACT OR GRANT NO		9a ORIGINATOR'S REPORT NUMBER	
b PROJECT NO NONE		ACTIV Project No. AGG-25F	
c		9b OTHER REPORT NUMBER (Any other numbers that may be assigned this report)	
d		NONE	
10 AVAILABILITY/LIMITATION NOTICES Qualified requesters may obtain copies of this report from DDC			
11 SUPPLEMENTARY NOTES NONE		12 SPONSORING MILITARY ACTIVITY US ARMY, VIETNAM APO SAN FRANCISCO 96307	
13 ABSTRACT <p>The purpose of the project was to evaluate first generation night vision devices (Starlight Scope, Small, Hand-Held or Individual Weapon Mounted and Crew-Served Weapon Night Vision Sight) used by US Army units in the Republic of Vietnam (RVN) to obtain data on tactical employment, system performance, maintenance experience, and suitability of the Department of the Army basis of issue.</p> <p>The evaluation disclosed that the NVD was effectively employed in both offensive and defensive operations, and that its operational limitations were primarily those imposed by weather, terrain, and vegetation, rather than design.</p> <p>It was concluded that the NVD are of significant value to the combat soldier in Vietnam. Adoption of the recommended Department of the Army basis of issue and introduction of additional NVD into Vietnam before conclusion of the field evaluation were fully justified by the findings and conclusions of the study.</p>			

UNCLASSIFIED

Security Classification

14. KEY WORDS	LINK A		LINK B		LINK C	
	ROLE	WT	ROLE	WT	ROLE	WT
<p>NIGHT VISION DEVICES. SMALL STARLIGHT SCOPE CREW-SERVED WEAPON SIGHT VISION SIGHT COMBAT ENVIRONMENT, VIETNAM</p>						

INSTRUCTIONS

1. ORIGINATING ACTIVITY: Enter the name and address of the contractor, subcontractor, grantee, Department of Defense activity or other organization (corporate author) issuing the report.

2a. REPORT SECURITY CLASSIFICATION: Enter the overall security classification of the report. Indicate whether "Restricted Data" is included. Marking is to be in accordance with appropriate security regulations.

2b. GROUP: Automatic downgrading is specified in DoD Directive 5200.10 and Armed Forces Industrial Manual. Enter the group number. Also, when applicable, show that optional markings have been used for Group 3 and Group 4 as authorized.

3. REPORT TITLE: Enter the complete report title in all capital letters. Titles in all cases should be unclassified. If a meaningful title cannot be selected without classification, show title classification in all capitals in parenthesis immediately following the title.

4. DESCRIPTIVE NOTES: If appropriate, enter the type of report, e.g., interim, progress, summary, annual, or final. Give the inclusive dates when a specific reporting period is covered.

5. AUTHOR(S): Enter the name(s) of author(s) as shown on or in the report. Enter last name, first name, middle initial. If military, show rank and branch of service. The name of the principal author is an absolute minimum requirement.

6. REPORT DATE: Enter the date of the report as day, month, year, or month, year. If more than one date appears on the report, use date of publication.

7a. TOTAL NUMBER OF PAGES: The total page count should follow normal pagination procedures, i.e., enter the number of pages containing information.

7b. NUMBER OF REFERENCES: Enter the total number of references cited in the report.

8a. CONTRACT OR GRANT NUMBER: If appropriate, enter the applicable number of the contract or grant under which the report was written.

8b, 8c, & 8d. PROJECT NUMBER: Enter the appropriate military department identification, such as project number, subproject number, system numbers, task number, etc.

9a. ORIGINATOR'S REPORT NUMBER(S): Enter the official report number by which the document will be identified and controlled by the originating activity. This number must be unique to this report.

9b. OTHER REPORT NUMBER(S): If the report has been assigned any other report numbers (either by the originator or by the sponsor), also enter this number(s).

10. AVAILABILITY/LIMITATION NOTICES: Enter any limitations on further dissemination of the report, other than those

imposed by security classification, using standard statements such as:

- (1) "Qualified requesters may obtain copies of this report from DDC."
- (2) "Foreign announcement and dissemination of this report by DDC is not authorized."
- (3) "U. S. Government agencies may obtain copies of this report directly from DDC. Other qualified DDC users shall request through _____."
- (4) "U. S. military agencies may obtain copies of this report directly from DDC. Other qualified users shall request through _____."
- (5) "All distribution of this report is controlled. Qualified DDC users shall request through _____."

If the report has been furnished to the Office of Technical Services, Department of Commerce, for sale to the public, indicate this fact and enter the price, if known.

11. SUPPLEMENTARY NOTES: Use for additional explanatory notes.

12. SPONSORING MILITARY ACTIVITY: Enter the name of the departmental project office or laboratory sponsoring (paying for) the research and development. Include address.

13. ABSTRACT: Enter an abstract giving a brief and factual summary of the document indicative of the report, even though it may also appear elsewhere in the body of the technical report. If additional space is required, a continuation sheet shall be attached.

It is highly desirable that the abstract of classified reports be unclassified. Each paragraph of the abstract shall end with an indication of the military security classification of the information in the paragraph, represented as (TS) (S) (C) or (U).

There is no limitation on the length of the abstract. However, the suggested length is from 150 to 225 words.

14. KEY WORDS: Key words are technically meaningful terms or short phrases that characterize a report and may be used as index entries for cataloging the report. Key words must be selected so that no security classification is required. Identifiers, such as equipment model designation, trade name, military project code name, geographic location, may be used as key words but will be followed by an indication of technical context. The assignment of links, roles, and weights is optional.

UNCLASSIFIED

Security Classification

LIBRARY
ARMED FORCES STAFF COLLEGE

UNCLASSIFIED

~~CONFIDENTIAL~~

4 MAR 2009

ARMED FORCES STAFF COLLEGE



3 4707 0006664 3

~~CONFIDENTIAL~~

UNCLASSIFIED