

UNCLASSIFIED

<b>AD NUMBER</b>	
<b>AD362110</b>	
<b>CLASSIFICATION CHANGES</b>	
<b>TO:</b>	<b>unclassified</b>
<b>FROM:</b>	<b>confidential</b>
<b>LIMITATION CHANGES</b>	
<b>TO:</b>	<b>Approved for public release, distribution unlimited</b>
<b>FROM:</b>	<b>Distribution authorized to U.S. Gov't. agencies and their contractors; Administrative/Operational Use; 25 OCT 1957. Other requests shall be referred to Director, Defense Atomic Support Agency, Washington, DC 20301.</b>
<b>AUTHORITY</b>	
<b>DNA ltr, 26 Jan 1981; DNA ltr, 26 Jan 1981</b>	

THIS PAGE IS UNCLASSIFIED

AD- 362110

SECURITY REMARKING REQUIREMENTS

DOD 5200.1-R, DEC 78

REVIEW ON 25 OCT 77

**THIS REPORT HAS BEEN DELIMITED  
AND CLEARED FOR PUBLIC RELEASE  
UNDER DOD DIRECTIVE 5200.20 AND  
NO RESTRICTIONS ARE IMPOSED UPON  
ITS USE AND DISCLOSURE.**

**DISTRIBUTION STATEMENT A**

**APPROVED FOR PUBLIC RELEASE,  
DISTRIBUTION UNLIMITED.**

UNCLASSIFIED

362110

ALL INFORMATION CONTAINED  
HEREIN IS UNCLASSIFIED  
EXCEPT WHERE SHOWN  
OTHERWISE

DNA etc  
26 Jan 81

Best Available Copy

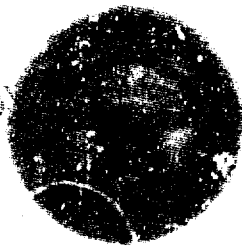

UNCLASSIFIED



## **SECURITY MARKING**

The classified or limited status of this report applies to each page, unless otherwise marked.

Separate page printouts **MUST** be marked accordingly.

"This document contains information affecting the National Defense of the United States within the meaning of the Espionage Laws, Title 18, U. S. C., Section 793 and 794. Its transmission or the revelation of its contents in any manner to an unauthorized person is prohibited by law."

EXCLUDED FROM AUTOMATIC  
REGRADING: DOD DIR 5200.10  
DOES NOT APPLY

" ONE HALF ORIGINAL SIZE "

attachment A

CONFIDENTIAL

AD 362110

FOREIGN ANNOUNCEMENT AND DISSEMINATION OF THIS REPORT IS NOT AUTHORIZED.

WT-927

OPERATION CASTLE PROJECT 6.4

Report to the Scientific Director

PROOF TESTING OF ATOMIC WEAPONS  
SHIP COUNTERMEASURES

FOREIGN ANNOUNCEMENT AND DISSEMINATION OF THIS REPORT IS NOT AUTHORIZED.

Classification (Cancelled) (Changed to **CONFIDENTIAL**)  
By Authority of DIASASC-3 memo, 7 Sept 1960  
By [Signature] Date 30 June 1965

G. G. Molumphy, CAPT., USN  
M. M. Bigger

U. S. Naval Radiological Defense  
Laboratory  
San Francisco 24, California

U.S. GOVERNMENT PRINTING OFFICE  
FROM DDC.

Issuance Date: October 25, 1957

**FORN RELEASE DATE**  
Handle as Restricted Data in foreign dissemination. Section 112, Atomic Energy Act of 1954.

Agency to: [Signature]  
Director  
Defense Atomic Support Agency  
Washington, D. C. 20301

This material contains information affecting the national defense of the United States within the meaning of the espionage laws Title 18, U. S. C., Secs. 793 and 794, the transmission or revelation of which in any manner to an unauthorized person is prohibited by law.

CONFIDENTIAL

Excluded from automatic downgrading and declassification

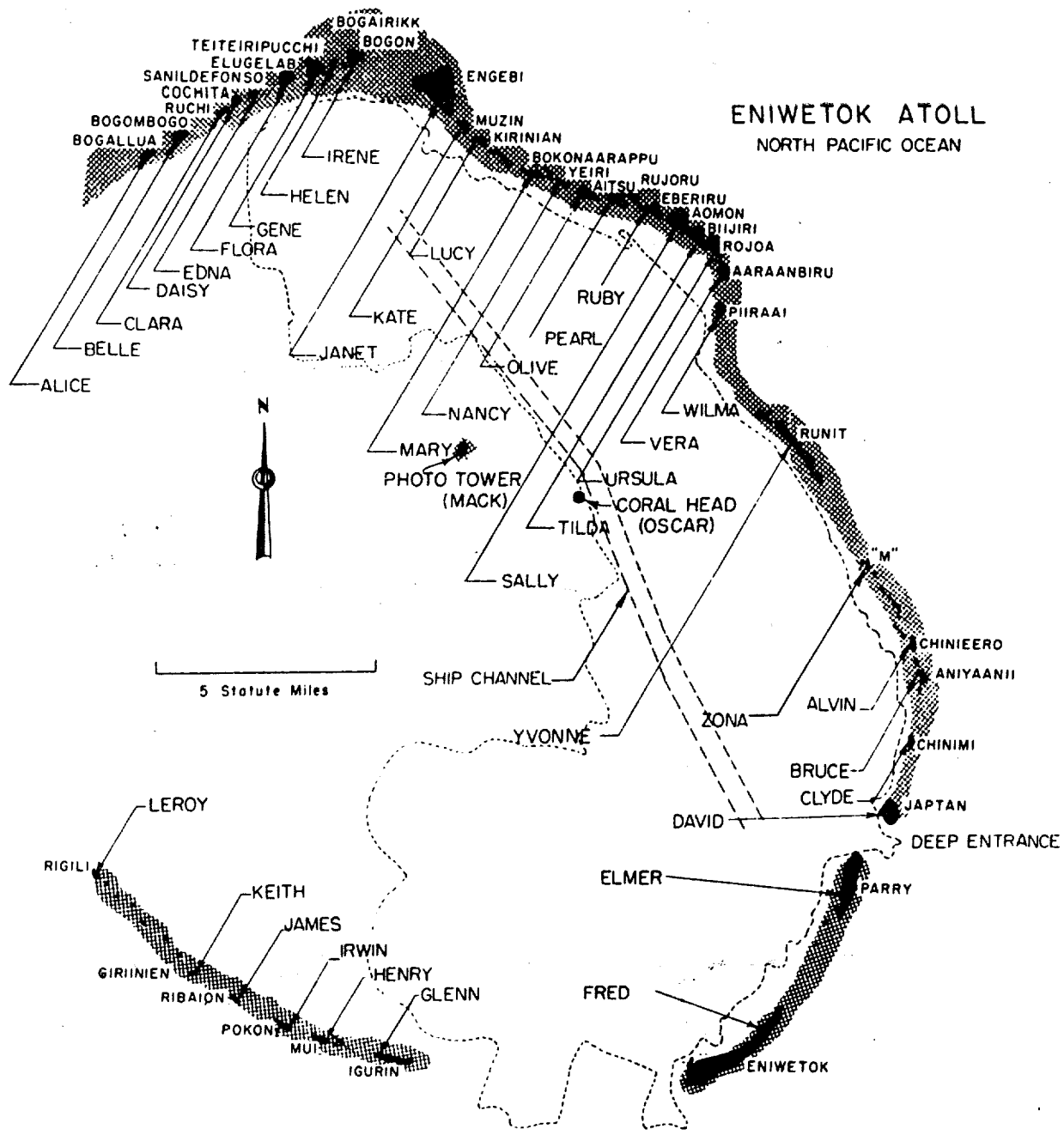

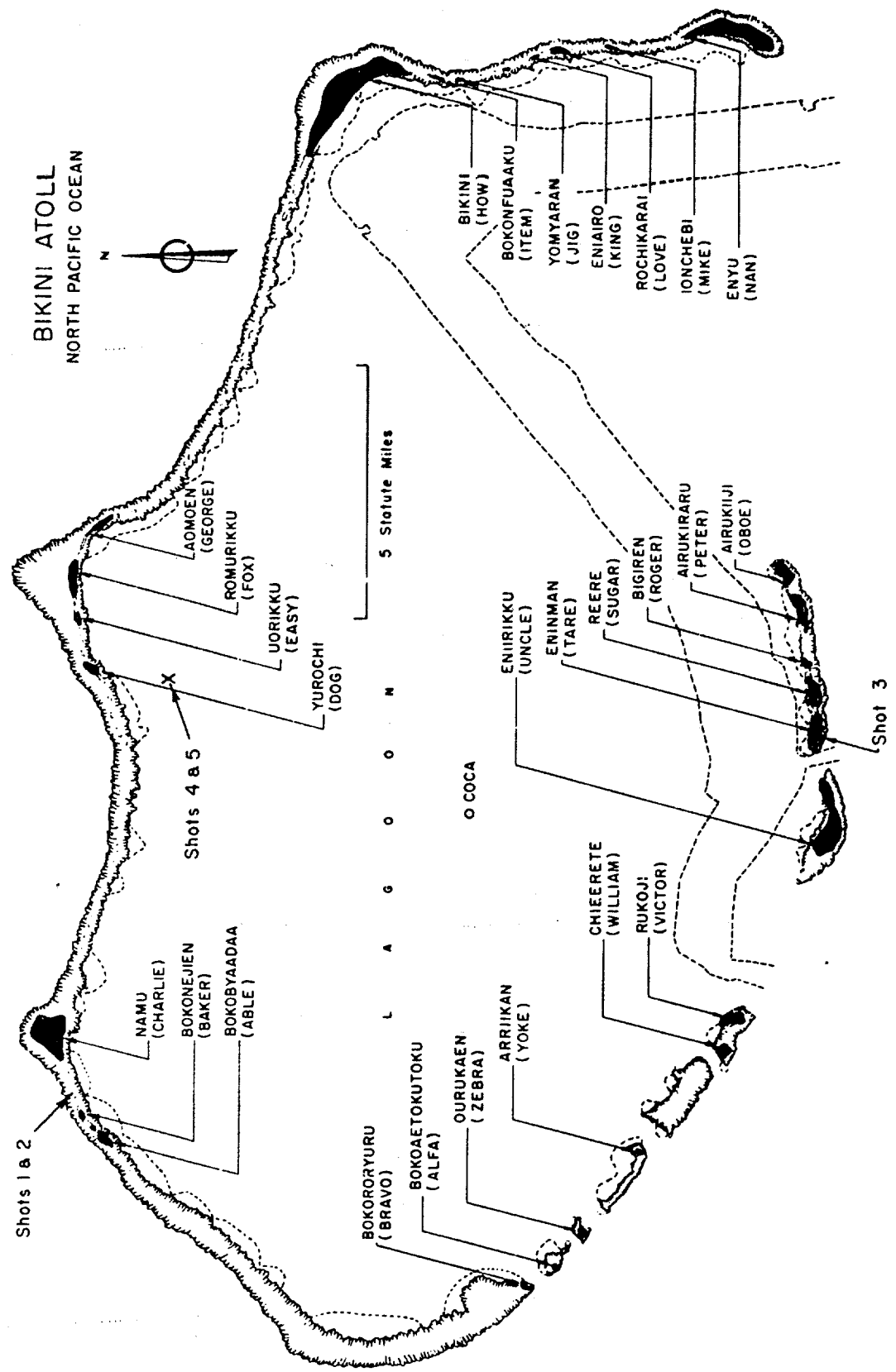

GENERAL SHOT INFORMATION

	Shot 1	Shot 2	Shot 3	Shot 4	Shot 5	Shot 6
DATE	1 March	27 March	7 April	26 April	5 May	14 May
CODE NAME (Unclassified)	Bravo	Romeo	Koon	Union	Yankee	Nectar
TIME*	06:40	06:25	06:15	06:05	06:05	06:15
LOCATION	Bikini, West of Charlie (Namj) on Reef	Bikini, Shot 1 Crater	Bikini, Tare (Eninman)	Bikini, on Barge at Intersection of Arcs with Radii of 6900' from Dog (Yurochi) and 3 Statute Miles from Fox (Aomoen).		Eniwetok, IVY Mike Crater, Flora (Elugelab)
TYPE	Land	Barge	Land	Barge	Barge	Barge
HOLMES & HARVER COORDINATES	N 170,617.17 E 76,163.98	N 170,635.05 E 75,950.46	N 100,154.50 E 109,799.00	N 161,698.83 E 116,800.27	N 161,424.43 E 116,688.15	N 147,750.00 E 67,790.00

\* APPROXIMATE

## ABSTRACT

The proof test of existing and proposed radiological countermeasures for naval ships and aircraft not in flight is presented in detail. In this part of Operation Castle, two test vessels, one equipped with a complete washdown system and the other not, were guided by remote control along relatively close courses through the fallout regions of four nuclear detonations.

Operation of washdown during fallout, until approximately 10 hr after detonation, achieved a reduction in dose rate of 90 to 96 percent and a reduction in accumulated dose of 87 to 94 percent at exposed locations. Subsequent washing for 2 hr only increased these reductions to 93 to 97 percent for dose rate and 89 to 95 percent for accumulated dose. The accumulated dose at exposed locations was as much as 300 r at 10 hr after detonation. The transit dose (dose from fallout prior to deposition) was estimated to have minor significance on a nonwashdown ship.

In the ship-shielding studies, the overall shielding factor was defined as the ratio of the dose rate in a compartment to that measured at an unshielded location above the weather deck. Sources of radiation were deposits of radioactivity on weather surfaces, the activity in the air during fallout, and the activity in the sea water. It was found that the overall shielding factor decreased with time and thickness of steel. This factor was greater for the washdown ship. Apparent absorption coefficients were found to increase regularly with time. Use of these coefficients in computing the shielding from activity deposited on the nonwashdown ship gave relatively close agreement with observed values.

Ship decontamination covered an extended period which affected the results as follows: (1) decontamination effectiveness exclusive of decay, 76 percent; (2) decontamination effectiveness plus decay, 80 to 90 percent. Thus it appears that tactical decontamination of a ship should be a mass operation in which all contaminated surfaces are attacked simultaneously to minimize unnecessary additional dosage to exposed personnel. It is concluded that a washdown system is the most effective tactical decontamination countermeasure presently available and that for ships not so equipped a combination of firehosing and scrubbing with detergent is a satisfactory interim decontamination procedure. Strippable protective coatings must be further developed and improved before they can meet the requirements for a tactical decontamination procedure.

The interior contamination study indicated that the average airborne activity concentration in cubicles ventilated by unprotected duct systems was of the order of 0.02 percent of the average weatherside concentration. The paper-filter and electrostatic-precipitator protective devices in the ventilation system reduced this value by a factor of 94 to 98 percent.

The aircraft studies revealed that the washdown reduced the cockpit dose rate by 94 to 95 percent. The immediate effect of salt water from the washdown or decontamination operations was not serious to the planes; if their ignition systems are protected, the planes will remain in flight condition. Decontamination effectiveness on aircraft unprotected by washdown was 50 to 60 percent by firehosing or hot-liquid-jet cleaning.

A subsequent scrubbing with detergent or solvent emulsion should increase these figures to 75 to 90 percent. Contaminant distribution was not uniform over the planes but depended greatly on the relative direction and velocity of the wind as well as the type of contaminant.

Evaluation of the air monitor showed that the present design could be used to indicate the presence of  $10^{-9}$  curies of beta activity per cubic meter of air in fields up to 0.5 r/hr. This should give satisfactory warning of the presence of beta emitters or incipient build-up of gamma emitters in regions where gamma background is less than 0.5 r/hr.

The gamma recording system used on the test ships proved basically sound but needs improving for simplicity and reliability.

Adequate survey information was obtained within dosage limitations by large numbers of unskilled monitors who were briefly instructed on the use of monitoring instruments in a standardized procedure.

For personnel protection, a procedure is presented by which the average radiation level aboard a contaminated ship may be estimated on the basis of dose-rate measurements taken from a neighboring vessel. Extensive recommendations concerning radiological safety instrumentation, procedures, and equipment are given.

Three general categories of recommendations are given in the report. These are: (1) use of equipment or procedures; (2) need for further investigation in specific areas; and (3) improvement of testing techniques.

## FOREWORD

This report is one of the reports presenting the results of the 34 projects participating in the Military Effects Tests Program of Operation Castle, which included six test detonations. For readers interested in other pertinent test information, reference is made to WT-934, "Summary Report of the Commander, Task Unit 13, Programs 1-9," Military Effects Program. This summary report includes the following information of possible general interest.

- a. An overall description of each detonation, including yield, height of burst, ground zero location, time of detonation, ambient atmospheric conditions at detonation, etc., for the six shots.
- b. Discussion of all project results.
- c. A summary of each project, including objectives and results.
- d. A complete listing of all reports covering the Military Effects Tests Program.

## PREFACE

This report presents the results of a group of experimental investigations which are a part of a continuing program to develop adequate shipboard damage-control measures against the radiological effects of nuclear weapons. Because no precise quantitative information on the extent or magnitude of the types of radiation to be encountered and their biological effects was available, every effort has been made to present complete data, together with the circumstances under which they were obtained. The result is an extensive report, even though many operational and logistic details have been omitted. Its length appears justified, since adequate test background information is made available for any future evaluation of the results. It is hoped that the details presented may prove useful in planning other countermeasure field tests.

The introductory chapter gives the background of the investigation, its specific objectives, the plan of attack, and the extent of the operation. Each of the other chapters treats a specific objective and constitutes a complete report written by the individual responsible for that phase of the investigation. Each of these chapters has a separate appendix containing pertinent supplementary material. Hence, a reader whose concern is with a particular problem may satisfy his needs by reading the introductory chapter and the appropriate subsequent chapter with its appendix.



## ACKNOWLEDGMENTS

The extensive scope of Project 6.4, Operation Castle, required the coordination and cooperation of many people from various Naval Activities and Task Force Units. Acknowledgment is made to personnel from the following naval activities for their part in the work. Mare Island Naval Shipyard, ship conversion, including remote control; San Francisco Naval Shipyard, final outfitting of the test ships; and Naval Air Station, Alameda, Calif., remote control aircraft conversion.

The active interest and personal participation of the Program Director, Lt. Col. D. L. Prickett, USAF, was of material assistance in Project 6.4 and is gratefully acknowledged.

Task Group 7.3 furnished approximately 300 men for a total of 980 man-days from various ships for survey, sampler recovery, and ship and aircraft decontamination work. This assistance was coordinated by ChCarp A. E. Williams of the USS Estes. He worked closely with the project personnel, daily requesting the men needed, screening dosimetry records, and rotating personnel as required. The assistance rendered is gratefully acknowledged.

The two test ships (YAG 39 and YAG 40), the Molala (ATF 106), and the control aircraft (P2V5) supporting Project 6.4 operated as Task Unit 7.3.6. The Tawakoni (ATF 114) also served with this unit for short periods. Besides the assigned support duties, Task Unit 7.3.6 furnished 32 men, principally from the ATF 106, for a total of approximately 120 man-days for the survey and final decontaminations of the test ships. The cooperation and assistance of the officers and enlisted men of this unit, some of whom served on direct assignment to Project 6.4 and all of whom contributed to its operation, is deeply appreciated. The officers of these units were:

### YAG 39

H. W. Ancell, Jr.	LCDR USN	Officer-in-charge
G. B. Hunt	LT USN	Assistant Officer-in-charge
B. E. Lodge	LTJG USN	Supply Officer
O. E. Krogstad	ChMach USN	Engineering Officer

### YAG 40

J. S. Malayter	LCDR USN	Officer-in-charge
W. H. Norris	LT USN	Assistant Officer-in-charge
R. E. Laux	LTJG USN	Supply Officer
R. F. Serghison	ChMach USN	Engineering Officer

### ATF 106

R. F. Reed	LT USN	Commanding Officer
W. B. Robertson	LTJG USN	Executive Officer

R. P. Jacobson	LTJG USN
R. L. Parker	ENS USN
J. A. Waggoner	ChMach USN
A. T. Robinson	ChBosn USN

P2V5

R. Borgstrom	LT USN	Pilot
J. Scholfield	LT USN	Copilot
J. A. Rose	LTJG USN	Navigator

Since the authors represent only a fraction of the project personnel, the roster below is given in acknowledgment of the efforts of those participating in the field work or other phases of the project.

Staff:

G. G. Malumphy, CAPT USN - Project Officer and Commander of Task Unit 7.3.6  
M. M. Eigger, NRDL - Deputy Project Officer

Military Evaluation Consultants:

W. E. Strobe, NRDL - specified ships' courses during the operation  
C. F. Ksanda, NRDL  
H. Scoville, Jr., AFSWP  
R. Maynard, CAPT USN

Deccontamination Advisor:

M. B. Hawkins, NRDL

Administration:

R. P. Nicolson, NRDL - Projects 2.5a and 2.6a  
D. D. Cole, NRDL - Projects 2.5a and 2.6a  
J. D. Ambrulevich, YN 3 USN - TU 7.3.6

Operations:

J. J. Kearns, BuShips - Ship's Operations Officer  
H. E. Sunde, BuShips - Assistant for Electronics  
S. R. Williamson, Mare Island Naval Shipyard - Assistant for Electronics  
F. W. Zieminski, Mare Island Naval Shipyard - Assistant for Machinery  
H. W. Norris, LT USN - YAG 40, small boat and vehicle transportation

Test Coordination:

W. J. Armstrong, BuShips - JTF Liaison

Special Assistant to Project Officer:

B. F. Bennett, CAPT USN  
A. C. Durham, BuShips  
R. A. Murdoch, BuShips

Technical Organization:

1. Washdown Evaluation  
H. R. Rinnert, NRDL

2. Shielding Studies  
C. F. Ksanla, NRDL
3. Ship Decontamination Studies  
F. S. Vine, NRDL - Group Leader  
R. H. Heiskell, NRDL  
R. J. Crew, NRDL  
J. D. Sartor, NRDL  
R. H. Black, NRDL  
W. L. Owen, NRDL  
N. J. Vella, NRDL  
R. F. D'Ambra, LTJG USN  
C. J. Strzemienski, LCDR USN  
N. G. Biasi, ATC USN  
E. Hoffman, DC 1 - YAG 39
4. Interior Contamination Studies  
  
N. R. Wallace, NRDL - Group Leader  
J. C. Sherwin, NRDL  
F. K. Kawahara, NRDL  
J. B. Zaccor, NRDL  
H. L. Johnston, NRDL  
A. E. Rexroad, Army Chemical Corps  
T. G. Goodale, NRDL  
L. L. Wiltshire, NRDL  
P. D. LaRiviere, NRDL  
J. W. Hendricks, NRDL
5. Air Monitor Evaluation  
  
B. M. Carder, NRDL
6. Aircraft Studies  
  
J. E. Howell, NRDL - Group Leader  
F. W. Heilman, Jr., NRDL  
W. S. Kehrer, NRDL  
G. Hildebrand, ADC USN - YAG 39  
E. R. Funk, ADC USN - YAG 40
7. Instrumentation  
  
H. S. Bright, NRDL  
H. A. Zagorites, NRDL  
A. W. Linder, Jr., LTJG USNR, NRDL  
P. A. Covey, NRDL  
D. W. Berte, NRDL  
R. F. Johnson LTJG USN, NRDL  
R. D. Jordan, LTJG USN, NRDL  
T. H. Bailey, ET 2 USN, NRDL  
P. C. Wilson, ET 2 USN, NRDL

W. Wilkerson, Sgt USA, TU-13  
M. I. Lipanovich, NRDL  
K. F. Sinclair, NRDL

8. Radiological Surveys and Fallout Photography

R. C. Barry, NRDL - Group Leader  
H. Lee, NRDL  
W. L. Banning, FA - YAG 39  
N. H. DeHoff, FA - YAG 39  
D. O. Penton, SN - YAG 39  
M. L. Hovey, SN - YAG 40  
K. M. Kassabaum, SN - YAG 40  
G. A. Tulley, SN - YAG 40

9. Personnel Protection

A. L. Baietti, NRDL - Group Leader and Radiological Safety Adviser  
to Project Officer

A. L. Smith, NRDL  
R. L. Hoover, NRDL  
W. G. Neall, NRDL  
F. A. Devlin, NRDL  
A. R. Nice, LTJG (MSC) USNR, NRDL  
G. C. Bell, LCDR USN  
J. Beland, LT USN  
J. D. Russell, ET 1 USN  
M. M. Stickney, Jr., ATC USN  
L. E. Ernst, HM 1 USN - YAG 39  
J. B. Bell, SA USN - YAG 39  
H. R. Keener, Jr., SA USN - YAG 39  
D. G. Cox, FA USN - YAG 39  
W. I. Vann, SA USN - YAG 39  
H. N. Stolon, HM 1 USN - YAG 40  
J. L. Simmons, SA USN - YAG 40  
W. E. Bonetti, SN USN - YAG 40  
C. E. Schumacher, SN USN - YAG 40  
F. D. Woolard, SN USN - YAG 40

Other Credits

Event predictions and ship location charts were prepared by E. A. Schuert, NRDL, with the assistance of T. A. Shirasawa, NRDL. The Transit Blue Book (Preparation of Operations Plan) was written by F. J. Goshe, NRDL, from material compiled by W. E. Strope, NRDL, and W. J. Armstrong, BuShips. All documentary photography was coordinated by F. W. Heilman, Jr., NRDL. The coordination of recorded gamma instrument requirements and the reductions of these data were the work of H. R. Rinnert, NRDL. The Preliminary Report of the Operation was prepared by C. F. Ksanda, NRDL, and H. R. Rinnert.

Appreciation is due Frances F. Brady, NRDL, and Ichiro Hayashi, NRDL, for their painstaking care in drawing the many diagrams used in the final report.

# CONTENTS

ABSTRACT . . . . .	7
FOREWORD . . . . .	9
PREFACE. . . . .	9
ACKNOWLEDGMENTS. . . . .	10
ILLUSTRATIONS. . . . .	22
TABLES . . . . .	32
CHAPTER 1 INTRODUCTION. . . . .	37
1.1 Background. . . . .	37
1.2 Objective . . . . .	37
1.3 Plan of Attack. . . . .	38
1.4 Organization. . . . .	38
1.5 Operations. . . . .	38
1.5.1 Ships' Courses and Fallout Predictions. . . . .	39
1.5.2 Shot 1 Operations . . . . .	41
1.5.3 Shot 2 Operations . . . . .	42
1.5.4 Shot 4 Operations . . . . .	43
1.5.5 Shot 5 Operations . . . . .	44
1.6 The Contaminating Event Along the Ships' Tracks . . . . .	44
1.6.1 Gross Description of Fallout Aboard Ships . . . . .	44
1.6.2 Maximum Accumulated Dosage. . . . .	45
1.6.3 Decay . . . . .	46
1.7 Plan of Final Report for Project 6.4. . . . .	47
1.7.1 Limitations of the Report . . . . .	47
CHAPTER 2 SHIP WASHDOWN COUNTERMEASURES . . . . .	48
2.1 Background and Theory . . . . .	48
2.2 Objective . . . . .	50
2.3 Instrumentation . . . . .	50
2.3.1 Washdown System . . . . .	50
2.3.2 Drainage Systems. . . . .	51
2.3.3 Recording Gamma Radiation Detector Stations . . . . .	51
2.3.4 Recording Wind Velocity Indicator . . . . .	56
2.4 Operations. . . . .	56
2.5 Results and Discussion. . . . .	56
2.5.1 Relative Magnitude of Fallout on the Test Ships. . . . .	57
2.5.2 Periods of Fallout and Estimate of Transit Dose. . . . .	58
2.5.3 Gamma Dose and Gamma Dose Rates . . . . .	59
2.5.4 Washdown Effectiveness for Exterior Areas . . . . .	62

2.5.5	Washdown Effectiveness for Interior Areas . . . . .	68
2.5.6	Some Factors Influencing the Washdown Effective- ness. . . . .	68
2.6	Conclusions . . . . .	72
2.7	Recommendations . . . . .	75
CHAPTER 3 SHIP SHIELDING		
3.1	Objective . . . . .	76
3.1.1	Measurements in Compartments Below Deck . . . . .	76
3.1.2	Measurements in Compartments of the Super- structure . . . . .	77
3.1.3	Measurements Inside Eight Steel Pipes . . . . .	77
3.2	Background and Theory . . . . .	77
3.3	Instrumentation . . . . .	79
3.4	Results and Discussion. . . . .	82
3.4.1	Below-deck Studies. . . . .	82
3.4.2	Superstructure Studies. . . . .	86
3.4.3	Steel Pipe Absorption Studies . . . . .	86
3.4.4	Comparison of Observed and Computed Shielding Factors . . . . .	101
3.5	Conclusions . . . . .	109
3.6	Recommendations . . . . .	112
CHAPTER 4 SHIP DECONTAMINATION . . . . .		
4.1	Background. . . . .	115
4.2	Objectives. . . . .	115
4.3	Instrumentation . . . . .	116
4.3.1	Decontamination Facilities. . . . .	116
4.3.2	Decontamination Zones . . . . .	116
4.3.3	Decontamination Equipment . . . . .	116
4.4	Operations. . . . .	118
4.4.1	Decontamination Procedures, Shot 2. . . . .	118
4.4.2	Sequence of Operations. . . . .	118
4.4.3	Decontamination Procedure, Zone 3 . . . . .	119
4.4.4	Operational Decontamination Procedures, Shot 2 . . . . .	119
4.4.5	Operational Decontamination Procedures, Shot 5 . . . . .	120
4.4.6	Radiological Surveys. . . . .	121
4.5	Results and Discussion. . . . .	121
4.5.1	Experimental Decontamination, YAG 40, Shot 2. . . . .	121
4.5.2	Operational Decontamination, YAG 40, Shot 2 . . . . .	125
4.5.3	Operational Decontamination, YAG 39, Shot 5 . . . . .	126
4.5.4	Appraisal of Nondestructive Decontamination Methods and Procedures. . . . .	127
4.5.5	Operational Decontamination, YAG 40, Shot 5 . . . . .	128
4.5.6	Effect of Washdown, YAG 39, Shot 5. . . . .	131
4.5.7	Decontamination versus Decay. . . . .	131
4.5.8	Radiation from Deck Gear and Fittings . . . . .	132
4.5.9	Airborne Contamination from Resurfacing (Tennant Machine) Operations . . . . .	132
4.5.10	Wipe Samples. . . . .	132
4.5.11	Utilization of Manpower . . . . .	133
4.5.12	Stay Time . . . . .	134

4.5.13	Special Protective Clothing . . . . .	134
4.5.14	Growth of Radioactivity . . . . .	135
4.5.15	Estimating Decontamination Operations . . . . .	135
4.6	Conclusions . . . . .	136
4.7	Recommendations . . . . .	136
CHAPTER 5 AIRCRAFT WASHDOWN AND DECONTAMINATION . . . . .		138
5.1	Objectives . . . . .	139
5.2	Background . . . . .	139
5.3	Instrumentation . . . . .	141
5.3.1	Fixed Gamma Recordings . . . . .	141
5.3.2	Surveys . . . . .	143
5.3.3	Decontamination Equipment . . . . .	143
5.4	Operations . . . . .	146
5.4.1	Washdown . . . . .	148
5.4.2	Material Damage Inspection . . . . .	148
5.4.3	Decontamination Methods . . . . .	148
5.4.4	Contamination Distribution . . . . .	154
5.5	Discussion and Results . . . . .	154
5.5.1	Washdown Effectiveness . . . . .	154
5.5.2	Material Damage . . . . .	156
5.5.3	Decontamination Effectiveness and Decay . . . . .	157
5.5.4	Comparison of Decontamination Methods . . . . .	159
5.5.4.1	Discussion . . . . .	169
5.5.5	Contamination Distribution . . . . .	177
5.6	Conclusions . . . . .	178
5.7	Recommendations . . . . .	179
CHAPTER 6 SHIPBOARD INTERIOR CONTAMINATION . . . . .		181
6.1	Background . . . . .	181
6.2	Objective . . . . .	182
6.3	Experiment Design . . . . .	182
6.3.1	Ventilation Spaces . . . . .	183
6.3.2	Boiler Systems . . . . .	186
6.3.3	Data to be Obtained . . . . .	188
6.4	Instrumentation . . . . .	191
6.4.1	Measuring Devices . . . . .	193
6.4.2	Installations in the Ventilation Systems . . . . .	195
6.4.3	Installations in the Boiler Systems . . . . .	197
6.4.4	Weatherside Installations . . . . .	199
6.5	Operations . . . . .	201
6.5.1	Instrument Timing . . . . .	202
6.5.2	Modifications for Shot 2, 4, and 5 . . . . .	202
6.6	Analysis and Results . . . . .	203
6.6.1	Analytical Techniques . . . . .	203
6.6.1.1	Time Distribution of Airborne Activity- Air Sampler Graphs . . . . .	203
6.6.1.2	Average Activity in Unit Volume of Air- Molecular and DMT Filters . . . . .	210

6.6.1.3	Deposition of Airborne Material - Duct Sections, Cone Liners . . . . .	211
6.6.2	Results of Measurements in the Ventilation Systems . . . . .	212
6.6.2.1	Concentration of Airborne Activity. . . . .	212
6.6.2.2	Effectiveness of Ventilation Counter-measures. . . . .	217
6.6.2.3	Deposition of Airborne Material. . . . .	220
6.6.3	Results of Measurements in Boiler Systems . . . . .	223
6.6.3.1	Concentration of Airborne Activity. . . . .	223
6.6.3.2	Deposition of Airborne Material . . . . .	226
6.6.4	Results of Weatherside Measurements . . . . .	226
6.6.4.1	Concentration of Airborne Activity. . . . .	230
6.6.4.2	Deposition of Airborne Material . . . . .	232
6.7	Discussion. . . . .	234
6.7.1	Comparison of Activity Concentration. . . . .	234
6.7.2	Sampling Conditions . . . . .	235
6.7.3	Airborne Material . . . . .	236
6.8	Conclusions . . . . .	237
6.9	Recommendations . . . . .	237
CHAPTER 7	AIR MONITORING EVALUATION . . . . .	239
7.1	Objective . . . . .	239
7.2	Background and Theory . . . . .	239
7.3	Description of Semi-Portable Air Monitor. . . . .	240
7.4	Operations. . . . .	241
7.5	Results and Discussion. . . . .	241
7.6	Conclusions . . . . .	247
7.7	Recommendations . . . . .	247
CHAPTER 8	INSTRUMENTATION . . . . .	248
8.1	Objective . . . . .	248
8.2	Preliminary Specifications. . . . .	248
8.3	Method of Attack. . . . .	249
8.4	Description of the Instrumentation System . . . . .	249
8.4.1	Gamma Recording Instruments . . . . .	249
8.4.2	Data Reduction Apparatus (DRA). . . . .	261
8.5	Performance of the Instruments. . . . .	268
8.6	Conclusions . . . . .	269
CHAPTER 9	RADIOLOGICAL SURVEYS AND FALLOUT PHOTOGRAPHY. . . . .	270
9.1	Objective . . . . .	270
9.2	Instrumentation . . . . .	271
9.2.1	Equipment for Fallout Photography . . . . .	272
9.3	Operations. . . . .	272
9.3.1	Radiological Surveys. . . . .	273
9.3.2	Fallout Photography . . . . .	274
9.4	Results and Discussion. . . . .	275
9.4.1	Summary of Instrument Evaluation. . . . .	275
9.4.2	Comparison of Decontamination Factors Derived from Beta and Gamma Measurements . . . . .	275
9.4.3	Contamination Distribution. . . . .	284



9.4.4	Fallout Photographs . . . . .	285
9.5	Conclusions . . . . .	285
9.6	Recommendations . . . . .	288
CHAPTER 10 RADIOLOGICAL PROTECTION OF PERSONNEL. . . . .		290
10.1	Background. . . . .	290
10.2	Objective . . . . .	290
10.3	Work of the Project 6.4 Rad-Safe Group. . . . .	291
10.3.1	Recovery Operations of the Test Ships . . . . .	291
10.3.2	Aboard the Test Ships . . . . .	292
10.3.3	Operations on Site Fred . . . . .	297
10.3.4	Photodosimetry Operations . . . . .	300
10.3.5	Support Facilities . . . . .	307
10.3.6	Air Sampling. . . . .	309
10.3.7	Instrumentation . . . . .	316
10.4	Conclusions and Recommendations . . . . .	318
APPENDIX A SUPPLEMENTARY MATERIAL ON WASHDOWN COUNTERMEASURES. . . . .		321
A.1	Ratio of Contamination Effects for the Two Ships, Assuming No Washdown Occurred. . . . .	321
A.2	Flow Rate and Wind Speed Graphs . . . . .	323
A.3	Tabulated Data. . . . .	326
APPENDIX B SUPPLEMENTARY MATERIAL ON SHIP SHIELDING . . . . .		336
B.1	Derivation of the Shielding Factor. . . . .	336
B.1.1	Components of the Shielding Factor. . . . .	336
B.1.2	Ratio of Shielding Factors, YAG 39 to YAG 40. . . . .	337
B.1.3	Relation between $f_g$ and $F$ . . . . .	338
B.2	Evaluation of the Shielding Factor under a 2-in.-Thick Deck. . . . .	339
B.3	Calculation of Shielding Factors for Deposited Activity . . . . .	340
B.3.1	Basic Approach. . . . .	340
B.3.2	Evaluation of the Shielding Factor. . . . .	341
APPENDIX C SUPPLEMENTARY MATERIAL ON SHIP DECONTAMINATION . . . . .		342
C.1	Protective Coating. . . . .	342
C.1.1	History . . . . .	342
C.1.2	Objectives. . . . .	342
C.1.3	Procedure . . . . .	342
C.1.4	Results and Discussions . . . . .	345
C.1.4.1	Application of Paint. . . . .	345
C.1.4.2	Durability. . . . .	345
C.1.4.3	Removal of Paint. . . . .	345
C.1.4.4	Effectiveness . . . . .	346
C.1.5	Conclusions . . . . .	346
C.1.6	Recommendations . . . . .	348
C.2	Gamma Dose Rate Curves. . . . .	348
C.2.1	Method of Determination . . . . .	350

C.3	Determination of Confidence Intervals . . . . .	352
C.3.1	Method . . . . .	352
C.4	Daily Log of Decontamination Operations . . . . .	354
C.5	Photographs . . . . .	356
APPENDIX D SUPPLEMENTARY MATERIAL ON AIRCRAFT WASHDOWN AND DECONTAMINATION . . . . .		363
D.1	Consideration of Some Factors Affecting Decontamination Results . . . . .	363
D.2	Compilation of Field Data . . . . .	364
D.2.1	Material Damage . . . . .	364
D.2.2	Washdown Effectiveness . . . . .	364
D.2.3	Decontamination Effectiveness . . . . .	375
D.2.3.1	Estimated Material Requirements for the Different Decontamination Processes . . . . .	375
D.2.4	Comparison of Beta and Gamma Data . . . . .	395
D.2.5	Contamination Distribution . . . . .	395
APPENDIX E SUPPLEMENTARY MATERIAL ON SHIPBOARD INTERIOR CONTAMINATION . . . . .		405
E.1	Flow Structure . . . . .	405
E.1.1	Airflow Characteristics . . . . .	405
E.1.2	Boiler Airflow Characteristics . . . . .	409
E.1.3	Temperature, Relative Humidity and Barometric Pressure . . . . .	410
E.2	Instrumentation Details . . . . .	413
E.2.1	Air Sampler Design . . . . .	413
E.2.2	Molecular Filter Collector Design . . . . .	416
E.2.3	Suction Unit Details . . . . .	417
E.2.4	Times of Instrument and Fan Operations and Instrument Field Performance . . . . .	418
E.3	Analysis Supplement . . . . .	419
E.3.1	Decay Correction of a Typical Activity versus Time Graph . . . . .	419
E.3.2	Activity Ratios between High and Low Flow Heads . . . . .	421
E.3.3	Estimate of Suction Unit Flow Rates . . . . .	422
E.3.4	Estimate of Beta Disintegration Rate and Calibration of Ionization Chamber . . . . .	424
E.3.5	Analysis of Weatherside Cone Liner - Shot 5 . . . . .	428
APPENDIX F DESIGN AND DEVELOPMENT CONSIDERATIONS OF INSTRUMENTATION . . . . .		430
F.1	Fixed Gamma Recorder . . . . .	430
F.2	Data Reduction Apparatus (DRA) . . . . .	433
APPENDIX G SUPPLEMENTARY MATERIAL ON RADIOLOGICAL SURVEYS AND FALLOUT PHOTOGRAPHY . . . . .		436
G.1	Instrumentation . . . . .	436
G.1.1	Radiacs . . . . .	436

G.1.1.1	AN/PDR-T1B . . . . .	436
G.1.1.2	AN/PDR-18A . . . . .	437
G.1.1.3	AN/PDR-27C . . . . .	437
G.1.2	Directional Beta Detector. . . . .	438
G.1.3	Directional Gamma Detector . . . . .	440
G.1.4	Wipe Sampling Equipment. . . . .	442
G.2	Survey Station Locations . . . . .	444
G.3	Preliminary Work on Fallout Photography. . . . .	444
APPENDIX H ESTIMATION OF RADIATION FLUX ABOARD YAG 40 DURING RECOVERY OPERATIONS . . . . .		452
H.1	Theoretical Considerations. . . . .	452
H.2	Experimental Measurements . . . . .	452
H.3	Conclusions . . . . .	455
REFERENCES	. . . . .	459

ILLUSTRATIONS

1.1	Organization chart for Project 6.4 . . . . .	39
1.2	Gamma dose rates from telemetered station on YAG 40 . . . . .	40
1.3	Ship's course - Shot 1 . . . . .	41
1.4	Ship's course - Shot 2 . . . . .	42
1.5	Ship's course - Shot 4 . . . . .	43
1.6	Ship's course - Shot 5 . . . . .	44
1.7	Accumulated Dosage for YAG 39 and YAG 40 after Shot 5 . . . . .	45
1.8	Gamma ionization decay curve - Operation Castle - based on Information from Projects 2.5a and 2.6a . . . . .	46
2.1	Hypothetical gamma dose rates on deck of ship caught in radioactive fall-out from a nuclear weapon . . . . .	49
2.2	Washdown of ship . . . . .	52
2.3	Flushdeck nozzle . . . . .	53
2.4	Spray nozzle . . . . .	53
2.5	Schematic Drain-Meter Installation . . . . .	54
2.6	General location of Detector Stations . . . . .	54
2.7	General locations of Detector Stations . . . . .	55
2.8	Estimated YAG 39/YAG 40 ratio of fall-out effects as a function of time after Shot 5, based on shielded Masthead Stations . . . . .	57
2.9	Shielded Masthead Station dose rates, with deck contributions subtracted and corrected for decay using 3 hr after Shot as base time . . . . .	58
2.10	Cumulative gamma dose averages for some exterior areas vs time after Shot 4 . . . . .	60
2.11	Cumulative gamma dose averages for some exterior areas vs time after Shot 5 . . . . .	60
2.12	Gamma dose rate averages for some exterior areas vs time after Shot 4 . . . . .	61
2.13	Gamma dose rate averages for some exterior areas vs time after Shot 5 . . . . .	61
2.14	Cumulative gamma dose averages for some interior areas vs time after Shot 4 . . . . .	63
2.15	Cumulative gamma dose averages for some interior areas vs time after Shot 4 . . . . .	63
2.16	Gamma dose rate averages for some interior areas vs time after Shot 4 . . . . .	63
2.17	Gamma dose rate averages for some interior areas vs time - Shot 4 . . . . .	64
2.18	Gamma dose rate average for some interior areas vs time after Shot 5 . . . . .	64

2.19	Gamma dose rate average for some interior areas vs time after Shot 5 . . . . .	65
2.20	Cumulative gamma dose average for some interior areas vs time after Shot 5 . . . . .	65
2.21	Cumulative gamma dose average for some interior areas vs time after Shot 5 . . . . .	65
2.22	Washdown effectiveness achieved on some exterior areas vs time after Shot 4, based on cumulative gamma dose . . . . .	66
2.23	Washdown effectiveness achieved on some exterior areas vs time after Shot 5, based on Cumulative gamma dose . . . . .	66
2.24	Washdown effectiveness achieved on some exterior areas vs time after Shot 4, based on dose rate . . . . .	67
2.25	Washdown effectiveness achieved on some exterior areas vs time after Shot 5, based on gamma dose rate . . . . .	67
2.26	Example of relationship between washdown effectiveness and decay corrected dose rates vs time after Shot 5. Data from Flight Deck . . . . .	69
2.27	YAG 39/YAG 40 ratio of gamma dose rates for some interior areas vs time after Shot 4 . . . . .	69
2.28	YAG 39/YAG 40 ratio of cumulative gamma dose for some interior areas vs time after Shot 4 . . . . .	69
2.29	YAG 39/YAG 40 ratio of gamma dose rate for some interior areas vs time after Shot 5 . . . . .	70
2.30	YAG 39/YAG 40 ratio of cumulative gamma dose for some interior areas vs time after Shot 5 . . . . .	70
2.31	Washdown effectiveness for some interior areas vs time after Shot 4, based on cumulative gamma dose . . . . .	70
2.32	Washdown effectiveness for interior areas vs time after Shot 4, based on gamma dose rate . . . . .	70
2.33	Washdown effectiveness for some interior areas vs time after Shot 5, based on cumulative gamma dose . . . . .	71
2.34	Washdown effectiveness for some interior areas vs time after Shot 5, based on gamma dose rate . . . . .	71
2.35	Washdown with wind abeam. . . . .	73
2.36	Relationship between relative wind direction and the Starboard/Port comparison of YAG 39/YAG 40 ratios of dose rates vs time after Shot 4. . . . .	74
3.1	Location of instruments used in the shielding studies . . . . .	78
3.2	Location and dimensions of the steel plates for the shielding studies . . . . .	80
3.3	Location and dimensions of the steel pipes for the shielding studies . . . . .	81
3.4	Shielding factors for Stations 25, 26, 27, and 28 on the YAG 40, Shot 2 . . . . .	83
3.5	Shielding factors for Stations 25, 26, 27, and 28 on the YAG 40, Shot 4 . . . . .	83
3.6	Shielding factors for Stations 25, 26, and 27 on the YAG 40, Shot 5 . . . . .	84
3.7	Shielding factors for Stations 25, 26, 27, and 28 on the YAG 39, Shot 2 . . . . .	84

3.8	Shielding factors for Stations 25, 26, 27, and 28 on the YAG 39, Shot 4 . . . . .	85
3.9	Shielding factors for Stations 25, 26, 27, and 28 on the YAG 39, Shot 5 . . . . .	85
3.10	Shielding factors for Stations 6, 7, and 8 on the YAG 40, Shot 2 . . . . .	87
3.11	Shielding factors for Stations 6, 7, and 8 on the YAG 40, Shot 4 . . . . .	88
3.12	Shielding factors for Stations 6, 7, and 8 on the YAG 40, Shot 5 . . . . .	89
3.13	Shielding factors for Station 7 on the YAG 40, Shot 4 . . . . .	90
3.14	Shielding factors for Station 7 on the YAG 40, Shot 5 . . . . .	91
3.15	Shielding factors for Station 64 on the YAG 40, Shot 2 . . . . .	92
3.16	Shielding factors for Station 64 on the YAG 40, Shot 4 . . . . .	92
3.17	Shielding factors for Station 64 on the YAG 40, Shot 5 . . . . .	93
3.18	Shielding factors for Station 64 on the YAG 39, Shot 4 . . . . .	93
3.19	Shielding factors for Station 64 on the YAG 39, Shot 5 . . . . .	94
3.20	Shielding factors for superstructure stations on the YAG 40, Shot 2 . . . . .	94
3.21	Shielding factors for superstructure stations on the YAG 40, Shot 4 . . . . .	95
3.22	Shielding factors for superstructure stations on the YAG 40, Shot 5 . . . . .	95
3.23	Shielding factors for superstructure stations on the YAG 39, Shot 4 . . . . .	96
3.24	Shielding factors for superstructure stations on the YAG 39, Shot 5 . . . . .	96
3.25	Ratio of dose rates on shielded instruments to rate on unshielded instrument (No. 15) YAG 40, Shot 2 . . . . .	97
3.26	Ratio of dose rates on shielded instrument to rate on unshielded instrument (No. 15) YAG 40, Shot 2 . . . . .	97
3.27	Ratio of dose rates on shielded instrument to rate on unshielded instrument (No. 15) YAG 40, Shot 4 . . . . .	98
3.28	Ratios of dose rates on shielded instruments to rate on unshielded instrument (No. 15) YAG 40, Shot 5 . . . . .	98
3.29	Ratios of dose rates on shielded instruments to rate on unshielded instrument (No. 15), YAG 40, Shot 5 . . . . .	99
3.30	Ratios of dose rates on shielded instruments to rate on unshielded instrument (No. 15) YAG 39, Shot 2 . . . . .	99
3.31	Ratios of rate on shielded instrument to rate on unshielded instrument (No. 15) YAG 39, Shot 4 . . . . .	100
3.32	Ratio of rate on shielded instrument to rate on unshielded instrument (No. 15) YAG 39, Shot 5 . . . . .	100
3.33	Absorption curves for different times based on average values of $\mu$ . . . . .	102
3.34	$\mu$ as a function of time . . . . .	103
3.35	Shielding factors as a function of deck thickness at 2 hr ( $\mu = 0.917 \text{ in.}^{-1}$ ) . . . . .	104
3.36	Shielding factors as a function of deck thickness at 3 hr ( $\mu = 0.928 \text{ in.}^{-1}$ ) . . . . .	105
3.37	Shielding factors as a function of deck thickness at 6 hr ( $\mu = 0.998 \text{ in.}^{-1}$ ) . . . . .	106

3.38	Shielding factors as a function of deck thickness at 10 hr ( $\bar{\mu} = 1.05 \text{ in.}^{-1}$ ) . . . . .	107
3.39	Shielding factors as a function of deck thickness at 20 hr ( $\bar{\mu} = 1.15 \text{ in.}^{-1}$ ) . . . . .	108
3.40	Comparison of computed and observed shielding factors, YAG 40, Station 25 . . . . .	110
3.41	Comparison of computed and observed shielding factors, YAG 40, Station 25 . . . . .	110
3.42	Comparison of computed and observed shielding factors, YAG 40, Station 27 . . . . .	111
3.43	Comparison of computed and observed shielding factors, YAG 40, Station 28 . . . . .	111
4.1	Decontamination zones of ship's weather deck . . . . .	117
4.2	Evaluation of experimental decontamination procedures, YAG 40, Shot 2 . . . . .	122
4.3	Gamma dose received by decontamination team for initial level of 1 r/hr, neglecting effects of decay . . . . .	124
4.4	Evaluation of decontamination procedures, YAG 40, Shot 2 . . . . .	126
4.5	Evaluation of Tennant machine resurfacing of wood boat deck YAG 40 . . . . .	127
4.6	Evaluation of decontamination procedures after washdown, YAG 39, Shot 5 . . . . .	128
4.7	Evaluation of decontamination procedure, YAG 40, Shot 5 . . . . .	129
4.8	Evaluation of Tennant machine resurfacing of wood boat deck, YAG 40, Shot 5 . . . . .	130
5.1	Washdown nozzle in operation . . . . .	140
5.2	Preliminary washdown system for aircraft . . . . .	140
5.3	Location of fixed gamma recording stations . . . . .	142
5.4	Plan view of the fixed gamma recording stations . . . . .	142
5.5	View of cockpit area showing the condition of the painted surfaces and some of the survey points . . . . .	144
5.6	Survey teams taking beta and gamma survey readings. The white dome in the right foreground contains the fixed gamma detector Station 70. . . . .	145
5.7	Rear view of heavy duty cleaner showing control panel and hook-up for use as a steam generator . . . . .	146
5.8	Operator adjusting control valves on the hot-liquid-jet unit. The unit is secured on top of the barrel which holds the detergent solution . . . . .	147
5.9	Washdown system in operation on the YAG 39, view from aft. . . . .	149
5.10	Washdown system in operation on the YAG 39, view from port side . . . . .	150
5.11	Washdown system in operation on the YAG 39, view from after port quarter . . . . .	151
5.12	Rinsing with the hot liquid jet showing how a fork lift was used to allow nozzle-man to wash to top of the fuselage and engine . . . . .	152
5.13	Washdown effectiveness for Shot 4 . . . . .	155
5.14	Washdown effectiveness for Shot 5 . . . . .	155

5.15	Decay at Station 69 (cockpit station) of the aircraft from the YAG 40 during the decontamination phase after Shot 2 . . .	158
5.16	Percent of original contaminant remaining versus manpower . . .	170
5.17	Percent of original contaminant remaining versus manpower for Condition A, Shot 2, YAG 40 . . . . .	170
5.18	Percent of original contaminant remaining versus manpower for Condition B, Shots 4 and 5, YAG 40 . . . . .	171
5.19	Percent of original contaminant remaining versus manpower for Condition C-2, Shots 4 and 5, YAG 39 . . . . .	171
6.1	Locations of test areas aboard the YAG 39 and YAG 40 . . . . .	184
6.2	Plan view of the top of the deckhouse on the YAG 40 . . . . .	186
6.3	Plan view of the main deck level inside the deckhouse on the YAG 40 . . . . .	187
6.4	Plan view of test cubicles in the No. 3 hold of the YAG 40 . . . . .	188
6.5	Elevation of a typical ventilation intake duct. . . . .	189
6.6	Elevation of typical exhaust duct . . . . .	190
6.7	Elevation of the intake duct of Condition IV on the YAG 40 . . . . .	190
6.8	Elevation of weatherside intake ducts of Conditions V and VI on the YAG 40 . . . . .	191
6.9	Schematic of the boiler air systems on the YAG 39 and YAG 40 . . . . .	192
6.10	Typical duct assembly . . . . .	194
6.11	Schematic of typical short type continuous air sampler installations . . . . .	196
6.12	Typical air sampler and suction unit arrangement. . . . .	197
6.13	Typical weatherside continuous air sampler installations. . . . .	200
6.14	View of weatherside air sampler opened for recovery or maintenance . . . . .	201
6.15	Air sampler and duct section sampling stations, Part 1 . . . . .	204
6.16	Air sampler and duct section sampling stations, Part 2 . . . . .	205
6.17	Surface sample locations in the uptake space of the YAG 39 . . . . .	206
6.18	Surface sample locations in the uptake space of the YAG 40 . . . . .	207
6.19	Duct section locations in the boiler-air systems of the YAG 39 and YAG 40 . . . . .	208
6.20	Schematic of continuous air-sampler strip analyzer. . . . .	209
6.21	Scintillation gamma counter . . . . .	212
6.22	Comparison of activity concentrations as a function of time at S+10 days for Condition II, YAG 40, Shot 4 . . . . .	213
6.23	Comparison of activity concentrations as a function of time at S+10 days for Condition II, YAG 40, Shot 5 . . . . .	214
6.24	Comparison of Station 5 activity concentrations at Shot 4 as a function of time at S+10 days for the seven Conditions. . . . .	218
6.25	Comparison of Station 5 activity concentrations at Shot 5 as a function of time at S+10 days for the seven Conditions. . . . .	219
6.26	Comparison of Station 1 activity concentrations at Shot 4 as a function of time at S+10 days for Conditions I, II, IIA . . . . .	220
6.27	Comparison of Station 1 activity concentrations at Shot 5 as a function of time at S+10 days for Conditions I, II, and IIA . . . . .	221
6.28	Duct section activities at S+10 days for three shots, Condition I, YAG 40 . . . . .	223
6.29	Duct section activities at S+10 days for three shots, Condition II, YAG 40. . . . .	224



6.30	Duct section activities at S†10 days for three shots, Condition III, YAG 40 . . . . .	225
6.31	Duct section activities at S†10 days for three shots, Condition IV, YAG 40 . . . . .	225
6.32	Duct section activities at S†10 days for three shots, Condition V, YAG 40 . . . . .	226
6.33	Duct section activities at S†10 days for three shots, Condition VI, YAG 40. . . . .	227
6.34	Duct section activities at S†10 days for three shots, Condition IIA, YAG 39 . . . . .	228
6.35	Activity concentrations in the boiler air systems of the YAG 39 and YAG 40 as a function of time at S†10 days, Shot 4 . . . . .	229
6.36	Weatherside activity concentrations on the YAG 39 and YAG 40 as a function of time at S†10 days, Shots 4 and 5 . . . . .	231
7.1	Theoretical beta decay curves for Shots 1 and 2 . . . . .	245
7.2	Airborne beta contamination at the Flying Bridge of the YAG 40 at collection time. . . . .	246
7.3	Airborne beta contamination at Site Elmer, at collection time . . . . .	247
8.1	Gamma detector stations aboard the test ships . . . . .	250
8.2	Simplified schematic of the gamma detector channel. . . . .	251
8.3	The recycle relay . . . . .	252
8.4	Two sizes of the four detectors; A, B, and C were the larger ones, D, and smaller. . . . .	254
8.5	Detector electrometer assembly showing main relay and Teflon-insulated center post. . . . .	255
8.6	Detector electrometer assembly showing the lead-covered integrating capacitor . . . . .	256
8.7	Typical below-deck gamma detector with Lucite dome cover . . . . .	257
8.8	Typical below-deck gamma detector with cover removed . . . . .	258
8.9	Low energy response of Detectors A, B, and C. . . . .	259
8.10	Low energy response of Detector D . . . . .	259
8.11	Typical recorder chart . . . . .	260
8.12	Two complete instrument rack installations . . . . .	261
8.13	Complete recorder room installation . . . . .	262
8.14	Simplified block diagram of the data reduction apparatus . . . . .	263
8.15	Front view of the data reduction apparatus. . . . .	264
8.16	Tape recorder and Patch Panel . . . . .	265
9.1	Fallout photography station . . . . .	273
9.2	Radiation contours from original beta survey on the YAG 40 after Shot 2. 31 March 1954 . . . . .	277
9.3	Radiation contours from original gamma survey on the YAG 40 after Shot 2. 31 March 1954 . . . . .	278
9.4	Radiation contours from decontamination beta survey on the YAG 40 after Shot 2. 6 April 1954 . . . . .	278
9.5	Radiation contours from decontamination gamma survey on the YAG 40 after Shot 2. 6 April 1954 . . . . .	279
9.6	Radiation contours from original beta survey on the YAG 40 after Shot 4, 29 April 1954 . . . . .	279

9.7	Radiation contours from original gamma survey on the YAG 40 after Shot 4. 29 April 1954 . . . . .	280
9.8	Radiation contours from original beta survey on the YAG 39 after Shot 5. 8 May 1954 . . . . .	280
9.9	Radiation contours from original gamma survey on the YAG 39 after Shot 5. 8 May 1954 . . . . .	281
9.10	Radiation contours from original beta survey on the YAG 40 after Shot 5. 8 May 1954. . . . .	282
9.11	Radiation contours from original gamma survey on the YAG 40 after Shot 5. 8 May 1954. . . . .	283
9.12	Fallout photograph enlarged (7.3 X) from an aerosol camera frame from Shot 5. . . . .	286
9.13	Photomicrograph (90 X) of circular area of Figure 9.12 showing double image characteristic of a clear liquid droplet. . . . .	287
9.14	Fallout photograph enlarged (7.3 X) from an aerosol camera frame from Shot 5. . . . .	288
9.15	Photomicrograph (90 X) of circular area of Figure 9.14 showing three small particles. . . . .	289
10.1	Gamma background record of fallout on Site Elmer following Shot 2 . . . . .	312
10.2	Specific activity record of fallout on Site Elmer following Shot 2 . . . . .	312
A.1	Washdown supply flow rate aboard the YAG 39 versus time after Shots 4 and 5 . . . . .	323
A.2	Drainage flow rates from various areas of YAG 39 versus time after Shots 4 and 5. . . . .	324
A.3	Relative wind speed and direction aboard YAG 39 and YAG 40 versus time after Shots 4 and 5. . . . .	325
A.4	Relative wind speed and direction aboard YAG 39 and YAG 40 versus time after Shot 2 . . . . .	326
C.1	Plan view of Section 3, YAG 40 showing areas of protective paint and monitoring stations. . . . .	343
C.2	Operating schedule for the teams removing the paint from the YAG 40 after Shot 2. . . . .	344
C.3	Average gamma dose rate aboard YAG 40 as a function of time after Shot 2 . . . . .	349
C.4	Average gamma dose rate aboard YAG 39 as a function of time after Shot 5 . . . . .	349
C.5	Average gamma dose rate aboard YAG 40 as a function of time after Shot 5 . . . . .	350
C.6	Forward deck area and flight deck as seen from bridge, YAG 39 . . . . .	357
C.7	Boat deck aft from starboard side, YAG 39. . . . .	357
C.8	Front of superstructure looking aft from flight deck, YAG 39 . . . . .	358
C.9	Deck area looking aft from top of wheel house, YAG 39. . . . .	358
C.10	Hose team washing deck of YAG 40 (Shot 2). . . . .	359
C.11	Drum mounted 1250-gal/hr Sellers unit and hand held delivery lance. . . . .	359

C.12	The 6000-gal/hr Sellers unit . . . . .	360
C.13	Turret nozzle used in conjunction with 6000-gal/hr Sellers unit . . . . .	360
C.14	YAG 40 showing Mare Island Formula 980 protective coating on decks and superstructure . . . . .	361
C.15	Hudson portable spraying rig used in applying caustic paint stripping solution . . . . .	361
C.16	Tennant floor machine and hand held Aurand resurfacing tool. . . . .	362
D.1	Gamma dose rates at fixed gamma stations aboard YAG 40 after Shot 2 . . . . .	369
D.2	Gamma dose rate at fixed gamma stations aboard YAG 40 after Shot 2 . . . . .	369
D.3	Gamma doses at fixed gamma stations aboard the ships after Shot 4 . . . . .	370
D.4	Gamma dose rates at fixed gamma stations aboard YAG 39 after Shot 4 . . . . .	370
D.5	Gamma dose rates at fixed gamma stations aboard YAG 40 after Shot 4 . . . . .	371
D.6	Gamma dose rates at fixed gamma stations aboard YAG 39 after Shot 4 . . . . .	371
D.7	Gamma dose rates at fixed gamma stations aboard YAG 40 after Shot 4 . . . . .	372
D.8	Gamma doses at fixed stations aboard ship after Shot 5 . . . . .	372
D.9	Gamma doses at fixed gamma stations aboard ship after Shot 5 . . . . .	373
D.10	Gamma dose rates at fixed gamma stations aboard YAG 40 after Shot 5 . . . . .	373
D.11	Gamma dose rates at fixed gamma stations aboard YAG 40 after Shot 5 . . . . .	374
D.12	Gamma dose rates at fixed gamma stations aboard YAG 39 after Shot 5 . . . . .	374
D.13	Gamma dose rates at fixed gamma stations aboard YAG 39 after Shot 5 . . . . .	375
D.14	Equipment hookup for firehosing with salt water. . . . .	381
D.15	P-500 pump used to boost the water pressure to that necessary for firehosing . . . . .	381
D.16	Equipment hookup for hot liquid jet wash with salt water . . . . .	382
D.17	Equipment hookup for hot liquid jet wash with fresh water. . . . .	382
D.18	Decontamination effectiveness for all operations on the aircraft aboard the YAG 40 after Shot 2. . . . .	383
D.19	Decontamination effectiveness for all operations on the aircraft aboard the YAG 40 after Shot 2. . . . .	384
D.20	Decontamination effectiveness for all operations on the aircraft aboard the YAG 39 after Shot 4. . . . .	385
D.21	Decontamination effectiveness for all operations on the aircraft aboard the YAG 39 after Shot 4. . . . .	386
D.22	Decontamination effectiveness for all operations on the aircraft aboard the YAG 40 after Shot 4. . . . .	387
D.23	Decontamination effectiveness for all operations on the aircraft aboard the YAG 40 after Shot 4. . . . .	388
D.24	Decontamination effectiveness for all operations on the aircraft aboard the YAG 40 after Shot 4. . . . .	389

D.25	Decontamination effectiveness for all operations on the aircraft aboard the YAG 39 after Shot 5 . . . . .	390
D.26	Decontamination effectiveness for all operations on the aircraft aboard the YAG 39 after Shot 5 . . . . .	391
D.27	Decontamination effectiveness for all operations on the aircraft aboard the YAG 39 after Shot 5 . . . . .	392
D.28	Decontamination effectiveness for all operations on the aircraft aboard the YAG 40 after Shot 5 . . . . .	393
D.29	Decontamination effectiveness for all operations on the aircraft aboard the YAG 40 after Shot 5 . . . . .	394
D.30	Comparison of average TlB versus fixed gamma readings for aircraft aboard the YAG 40 after Shot 2 . . . . .	399
D.31	Comparison of average TlB versus fixed gamma readings for aircraft aboard the YAG 40 after Shot 5 . . . . .	399
D.32	Reduction of the beta to gamma ratio on test plates by washing them with the firehose. . . . .	400
D.33	Reduction of the beta to gamma ratio on test plates by washing them with the hot liquid jet. . . . .	400
D.34	Reduction of the beta to gamma ratio on test plates by scrubbing them with detergent and rinsing . . . . .	401
D.35	Reduction of the beta to gamma ratio on test plates by scrubbing them with detergent and rinsing . . . . .	401
D.36	Reduction of the beta to gamma ratio on test plates by scrubbing them with Gunk. . . . .	402
D.37	Location of regular monitor stations on the aircraft. . . . .	403
D.38	Location of special monitor stations for Shot 2 initial survey for contaminant distribution. . . . .	404
E.1	Pitot traverses for the six test conditions . . . . .	407
E.2	Pitot traverses in boiler air intake duct of the YAG 39 . . . . .	411
E.3	Pitot traverses in boiler air intake duct of the YAG 40 . . . . .	412
E.4	Schematic of long-and-short type air samplers . . . . .	415
E.5	Molecular filter collector. . . . .	417
E.6	Schematic diagram of arrangement of suction unit. . . . .	418
E.7	Comparison of curves of activity versus time for Condition II, Station 5, Shot 5 corrected to time of activity arrival and corrected to S+10 days. . . . .	421
E.8	Particle collector suction unit flow rates versus time, Shot 4. . . . .	422
E.9	Particle collector suction unit flow rates versus time, Shot 5. . . . .	423
E.10	Flow rate versus time for fire room air sampler suction units, Shot 5. . . . .	424
E.11	Absorption curves of isotope standards. . . . .	425
E.12	Absorption curves of cone liner and molecular filter samples. . . . .	426
E.13	Determination of apparent beta components for comparison of sample and standard absorption curves . . . . .	427
E.14	Calibration curve of ionization and scintillation counters. . . . .	428
E.15	Activity corrected to S+27 days for cone liner taken from deck house air sampler on YAG 40 at Shot 5. . . . .	429
F.1	Characteristic curve of the inverted triode . . . . .	433

G.1	Beta directional instrument, RBI-12 . . . . .	438
G.2	Beta direction instrument with case removed to show electronic components and double bucking ion chambers. . . . .	438
G.3	Directional gamma detector, RGG-1 . . . . .	441
G.4	Close-up of directional gamma detector, showing GM tube in center of spherical shield. . . . .	441
G.5	Automatic pressure regulated wipe sampler . . . . .	443
G.6	Wipe sample kit, including filter paper, rubber stopper pressure applicator . . . . .	443
G.7	Location of the stations surveyed on the weather deck . . . .	445
G.8	Location of stations surveyed in Sections 1 and 2 for the shielding studies . . . . .	446
G.9	Location of survey stations in the ventilation cubicles . . .	447
G.10	Water spray, enlarged (7.3 X) from an aerosol camera frame. .	449
G.11	Photomicrograph (90 X) of a section of Figure G.10 showing characteristic tear-drop images of rapidly moving water particles . . . . .	449
G.12	Wires photographed at an initial 12:1 reduction illuminated by ordinary room light. . . . .	450
G.13	Same wire photographed as above but illuminated by a single flash discharge from the electronic flash lamp. . . . .	450
H.1	Percent of radiation flux at 1 ft as a function of the distance from the deck of the YAG 40 . . . . .	453
H.2	Distance versus time during YAG 40 recovery after Shot 2. . .	453
H.3	Radiation flux as a function of distance during YAG 40 recovery after Shot 2 . . . . .	454
H.4	Distance versus time during YAG 40 recovery after Shot 4. . .	455
H.5	Radiation flux versus distance during YAG 40 recovery after Shot 4. . . . .	456
H.6	Distance versus time during recovery of YAG 40 after Shot 5 .	457
H.7	Radiation flux versus distance during YAG 40 recovery after Shot 5. . . . .	457

TABLES

2.1	Average water flow over exterior deck areas . . . . .	68
3.1	Apparent absorption coefficients, $\bar{\mu}$ , from steel pipe studies.	101
4.1	Comparison of beta contaminant removal on the YAG 40 after Shot 2 as determined by wipe samples counts and RBI-12 beta survey meter measurements . . . . .	133
4.2	Data for estimating decontamination operations . . . . .	135
5.1	Decontamination methods and their component steps . . . . .	153
5.2	Summary of material damage inspections . . . . .	153
5.3	Gamma record for decontamination phase of the YAG 40 aircraft after Shot 2 . . . . .	159
5.4	Gamma record for decontamination phase of the YAG 40 aircraft after Shot 5 . . . . .	160
5.5	Aircraft decontamination effectiveness results . . . . .	162
5.6	Test plate decontamination effectiveness results . . . . .	164
5.7	Decontamination effectiveness under Condition A . . . . .	166
5.8	Decontamination effectiveness under Condition B . . . . .	167
5.9	Decontamination effectiveness under Condition C-1 . . . . .	167
5.10	Decontamination effectiveness under Condition C-2 . . . . .	167
5.11	Decontamination working percentages under Condition B, based mainly on aircraft data . . . . .	168
5.12	Decontamination working percentages under Condition C-1, based mainly on aircraft data . . . . .	168
5.13	Decontamination working percentages under Condition C-2, based mainly on aircraft data . . . . .	168
5.14	Summary of time and manpower studies of decontamination . . . . .	174
5.15	Time and manpower necessary for decontamination effectiveness values . . . . .	174
5.16	Wipe sample data, aircraft from YAG 40 after Shot 2 . . . . .	176
5.17	Doses to decontamination crews working on aircraft from the YAG 40 after Shot 2 . . . . .	177
6.1	Instrumentation in ventilation cubicles . . . . .	195
6.2	Locations of particle collectors and molecular filters . . . . .	208
6.3	Beta count rates of the molecular filters in the ventilation spaces for Shots 4 and 5 . . . . .	215
6.4	Gamma count rates of the molecular filters in the ventilation spaces for Shots 2, 4, and 5 . . . . .	216
6.5	Active aerosol concentrations in below-decks ventilation spaces for three Shots . . . . .	216
6.6	Comparison of aerosol concentrations in the test cubicles for three Shots . . . . .	222

6.7	Gamma counts of cone liners in ventilation systems for three Shots . . . . .	222
6.8	Beta count rates of the molecular filters in the fire rooms for Shots 4 and 5 . . . . .	227
6.9	Gamma count rates of the molecular filters in the fire rooms for three Shots . . . . .	228
6.10	Active aerosol concentrations in the fire rooms for Shots 2 and 5 . . . . .	229
6.11	Gamma activities of boiler air duct sections and surface samples for three Shots at S+10 days. . . . .	230
6.12	Gamma count rates for cone liners in boiler systems for three Shots at S+10 days. . . . .	232
6.13	Beta and gamma count rates of the weatherside molecular filters for Shots 2, 4, and 5 at S+10 days. . . . .	233
6.14	Surface activities of adhesive-coated papers for Shots 4 and 5 at S+10 days. . . . .	233
6.15	Surface activities of weatherside molecular filters for Shots 4 and 5 . . . . .	234
6.16	Gamma count rates for weatherside cone liners for three shots at S+10 days. . . . .	234
6.17	Ratios of gamma activity concentrations below and above decks for Shots 4 and 5 . . . . .	235
6.18	Ratio of activity concentrations below and above decks based on cone liner data for three Shots. . . . .	235
7.1	Shot 1 beta activity on the Flying Bridge of the YAG 40 . . .	241
7.2	Shot 2 beta activity on the Flying Bridge of the YAG 40 . . .	242
7.3	Build-up of beta activity on filter paper in barracks on Site Elmer, Shot 2. . . . .	243
7.4	Shot 4 beta activity on the Flying Bridge of the YAG 40 . . .	244
8.1	Characteristics of the ion chambers . . . . .	253
9.1	Decontamination factors and ratios of beta-gamma decontamination . . . . .	276
10.1	Radiation levels during recovery, YAG 40. . . . .	291
10.2	Radiation levels aboard YAG 40. . . . .	292
10.3	Personnel dosages during recovery . . . . .	292
10.4	YAG 39 radiation levels . . . . .	293
10.5	YAG 40 radiation levels . . . . .	294
10.6	Dosage increments, YAG and NRDL personnel . . . . .	294
10.7	Average daily dosage received by YAG decontamination personnel . . . . .	295
10.8	Average radiation levels aboard test ships during return to the Zone of the Interior, mr/hr . . . . .	296
10.9	Dosage received by YAG personnel during return to the Zone of the Interior, mr. . . . .	297
10.10	Summary of daily monitoring surveys . . . . .	299
10.11	Average dosage to personnel during Site Fred operation. . . .	300
10.12	Comparison of gamma dosages . . . . .	301

10.13	Comparison of expected and observed dosages for Project 6.4 badges . . . . .	302
10.14	Accumulated individual beta exposures. . . . .	303
10.15	Individual wrist - body badge data . . . . .	304
10.16	Beta to gamma dose ratio from film-badge data. . . . .	306
10.17	Environmental monitoring, Site Elmer . . . . .	306
10.18	Environmental monitoring, Rad-Safe Center. . . . .	306
10.19	Quantities of protective equipment issued. . . . .	308
10.20	Air sampling data, YAG 39 operations . . . . .	310
10.21	Air sampling data, YAG 40 operations . . . . .	311
10.22	Air sampling data, Site Fred operations. . . . .	313
10.23	Air sampling data, fallout activity. . . . .	314
10.24	Relation of particle size and jet stage. . . . .	315
10.25	Summary of the particle size information gained from Cascade Impactor air sampling. . . . .	316
10.26	Airborne activities expected from different rates of gamma buildup based on observed data, Site Elmer . . . . .	316
10.27	Above-deck gamma background levels and airborne concentrations from the Belle Grove . . . . .	317
10.28	Recommended allowable airborne concentrations. . . . .	317
A.1	Cumulative gamma does (r) for detector stations in exterior areas at various times after Shot 4. . . . .	326
A.2	Cumulative gamma dose (r) for detector stations on main deck at various times after Shot 4 . . . . .	327
A.3	Cumulative gamma dose (r) for detector stations on flight deck and top of house at various times after Shot 5. . . . .	327
A.4	Cumulative gamma dose (r) for detector stations on boat deck at various times after Shot 5 . . . . .	328
A.5	Cumulative gamma dose (r) for detector stations on main deck forward at various times after Shot 5 . . . . .	328
A.6	Cumulative gamma dose (r) for detector stations on main deck aft at various times after Shot 5 . . . . .	329
A.7	Gamma dose rate (r/hr) for detector stations in exterior areas at various times after Shot 4. . . . .	329
A.8	Gamma dose rate (r/hr) for detector stations on main deck at various times after Shot 4 . . . . .	330
A.9	Gamma dose rate (r/hr) for detector stations on flight deck and top of house at various times after Shot 5. . . . .	330
A.10	Gamma dose rate (r/hr) for detector stations on boat deck at various times after Shot 5 . . . . .	331
A.11	Gamma dose rate (r/hr) for detector stations on main deck forward at various times after Shot 5 . . . . .	331
A.12	Gamma dose rate (r/hr) for detector stations on main deck aft at various times after Shot 5 . . . . .	332
A.13	Cumulative gamma dose (mr) for interior detector stations at various times after Shot 4. . . . .	332
A.14	Cumulative gamma dose (r) for unshielded stations in super-structure above main deck at various times after Shot 5. . . . .	333
A.15	Cumulative gamma dose (mr) for detector stations below main deck at various times after Shot 5. . . . .	333



A.16	Gamma dose rate (mr/hr) for detector stations (interior) at various times after Shot 4 . . . . .	334
A.17	Gamma dose rate (r/hr) for detector stations in super-structure above main deck at various times after Shot 5 . . . . .	334
A.18	Gamma dose rate (mr/hr) for detector stations below main deck at various times after Shot 5. . . . .	335
A.19	Starboard boiler contribution to the radiation field in the firing isle as recorded at Station 59. Cumulative gamma dose (mr) and gamma dose rate (mr/hr) at various times after Shots 4 and 5. YAG 39/YAG 40 ratio . . . . .	335
C.1	Radiological protective coatings. Summary of data - Shot 2 . . . . .	347
C.2	Computation of the gamma decay curve for the YAG 39 after Shot 5. . . . .	351
C.3	Procedure "B" on boat deck. . . . .	353
D.1	Material damage inspection plan and results . . . . .	365
D.2	Material damage inspection plan and results . . . . .	365
D.3	Material damage inspection plan and results . . . . .	366
D.4	Material damage inspection plan and results . . . . .	366
D.5	Material damage inspection plan and results . . . . .	367
D.6	Material damage inspection plan and results . . . . .	367
D.7	Material damage inspection plan and results . . . . .	368
D.8	Material damage inspection plan and results . . . . .	368
D.9	Decontamination sequences at various times after Shots. . . . .	378
D.10	Comparison of decontamination effectiveness results from aircraft and test plates based on gamma survey. . . . .	379
D.11	Decontamination effectiveness - comparison of average T1B reading for aircraft aboard YAG 40 after Shot 2 versus Location 40 (high initial) versus Location 20 (low initial) . . . . .	379
D.12	Time and manpower studies of aircraft decontamination . . . . .	380
D.13	Beta to gamma ratios for test plates on YAG 40 after Shot 4 . . . . .	396
D.14	Beta to gamma ratios for test plates on YAG 40 after Shot 5 . . . . .	396
D.15	Beta contamination distribution after Shot 2. . . . .	397
D.16	Beta contamination distribution after Shot 2. . . . .	397
D.17	Beta contamination distribution after Shot 5. . . . .	398
E.1	Summary of ventilation duct constituents. . . . .	406
E.2	Flow rates through the ducts. . . . .	409
E.3	Static pressure deviations for Shots 2, 4, and 5. . . . .	409
E.4	Precipitron operations. . . . .	410
E.5	Boiler airflow characteristics for YAG 39 and YAG 40. . . . .	410
E.6	Average boiler airflow rate (cfm) . . . . .	413
E.7	Air velocities at sampling stations in YAG 40 boiler air system. . . . .	413
E.8	Temperature, humidity, and barometric pressure measurements for three Shots. . . . .	414
E.9	Operational timing for Shots 2, 4, and 5. . . . .	418
E.10	Linear speed of filter paper passing intake ports of the continuous air samplers . . . . .	419
E.11	Continuous air sampler performance for three Shots. . . . .	420
E.12	Molecular filter particle collector performance for three Shots . . . . .	420

E.13	Count rate and airflow ratios between high flow and low flow particle collector heads . . . . .	422
E.14	Total volume of air sampled by particle collectors. . . . .	423
G.1	Gamma sensitivity of beta probe . . . . .	440
G.2	Boiler air survey locations . . . . .	448
H.1	Typical data for radiation flux estimates for Shot 2. . . . .	455
H.2	Typical data for radiation flux estimates for Shot 4. . . . .	456
H.3	Typical data for radiation flux estimates for Shot 5. . . . .	458

# CONFIDENTIAL

## Chapter I INTRODUCTION

### 1.1 BACKGROUND

Studies had been made at U. S. Naval Radiological Defense Laboratory (NRDL) concerning ships contaminated by underwater atomic detonations at sea; radiological hazards from harbor detonations on both ships and shore installations; and the contaminating effects of atomic detonations on aircraft parked on the flight decks of carriers. Conclusions from these studies were tentative, because of uncertainties in the basic data, most of which were based on either laboratory results or theoretical extrapolations from the inadequate measurements of the Baker test at Operation Crossroads. However, these studies had indicated, even at distances well beyond those where serious physical damage to ships and installations could occur, a radiological hazard sufficiently severe to warrant full-scale testing.

Laboratory tests and ship trials, using simulants, had indicated that a semi-automatic washdown of the ship's weather surfaces was a rapid and effective means of reducing the radiation hazard to personnel during and after a contaminating attack. To evaluate the washdown performance in terms of reduction in radiation dosage during an actual fallout event required a full-scale test. Also, such a test was needed to supplement calculations which indicated substantial reductions in radiation dosage below decks from radioactivity deposited on weather surfaces and from airborne activity during the fallout.

Data on the entry of airborne radioactive material through ventilation and boiler air systems were needed to evaluate the hazard from interior contamination and to establish the requirements for countermeasures. Field testing of existing and proposed decontamination methods was required to determine their performance in minimizing the long-term hazard on shipboard. Finally, since contamination of aircraft on flight decks prevents use of undamaged planes after a contaminating attack, a full-scale test of the effectiveness of the washdown system and of decontamination methods on aircraft was needed. Project 6.4, Operation Castle, was designed to meet these needs.

### 1.2 OBJECTIVE

The general objective of Project 6.4 was to proof-test existing and proposed radiological countermeasures for naval ships and aircraft not in flight and to obtain basic knowledge of the radiological situation on ships and aircraft for further countermeasures development. This project also provided operational support for Project 6.5, which obtained information related to radiological contamination and countermeasures for shore targets.

The general objective of Project 6.4 was divided into nine specific problems: (1) evaluation of washdown countermeasure on ships; (2) determination of shielding effectiveness of ships' structures; (3) determination of tactical and industrial radiological recovery procedures of ships; (4) determination of interior ship contamination and the suitability of ventilation protective devices; (5) study of airborne contamination and air monitoring systems; (6) study of aircraft contamination and decontamination, with and without washdown countermeasure; (7) provision for the recording of gamma radiation intensity vs time and reduction of the data obtained; (8) procurement of radiological survey data and fallout photography; and (9) provision of radiological safety control and evaluation of existing radiological safety procedures and devices.

### 1.3 PLAN OF ATTACK

To accomplish the objective of Project 6.4, two test vessels were guided in relatively close company by remote control through the fallout regions of four nuclear detonations.

The vessels were the Liberty Ships YAG 39 and YAG 40. The YAG 39 was fully equipped with a washdown system; the YAG 40 had none. Structural modifications included the installation of a section of wood flight deck forward on both ships and a deck house forward of the superstructure to house equipment for ventilation studies. Both ships were equipped with automatic controls for speed and steering. The ships' propulsion machinery was timed to shut down automatically at any time up to 24 hr after setting the time at debarkation. Operation of the washdown system of the YAG 39 was accomplished by radio linkage.

After each shot, both ships were retrieved by tugs and towed unmanned to Eniwetok Lagoon and moored. Here the samples and recorded data were recovered; decontamination studies were made; monitoring and essential decontamination were accomplished in preparation for participation in the next shot. Deviations from this planned procedure are detailed in a subsequent section.

### 1.4 ORGANIZATION

Project 6.4 was a joint BuShips-NRDL effort. The organization chart in Figure 1.1 shows the principal billets and assignments. The connected areas numbered 1 through 9 indicate the problems into which the project objective was divided and the individuals in charge of the work on them.

### 1.5 OPERATIONS

Project 6.4 participated in Shots 1, 2, 4, and 5. Shot 1 was a land-surface shot; Shots 2, 4, and 5 were water surface shots. For the first two shots, both ships were unmanned and were controlled from a P2V-5 aircraft, with a secondary control party stationed aboard the USS BAIROKO (CVE-115). Experience from these tests indicated that manning the YAG 39 was both desirable and feasible. The YAG 39 was manned during Shots 4 and 5 by a special party who received instructions as to the course from the secondary control party on the BAIROKO, either

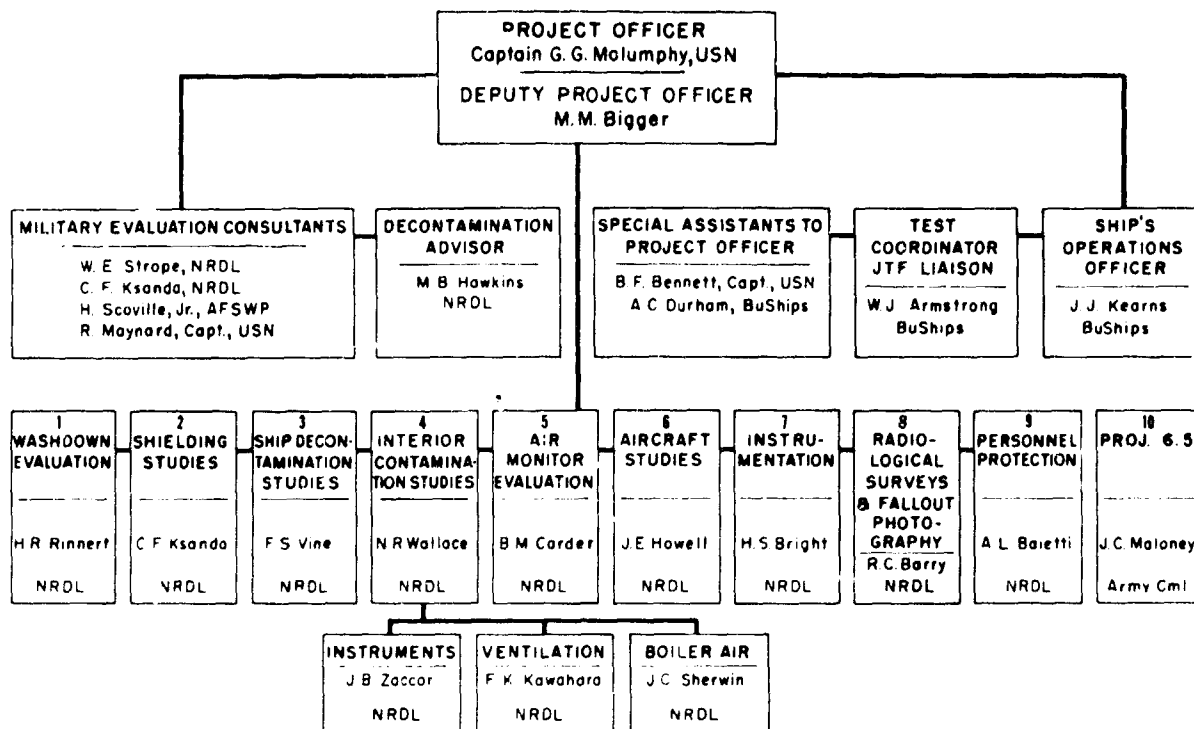

Figure 1.1 Organization chart for Project 6.4.

by voice radio via the P2V-5 (which served as communications relay station) or directly by code.

The timer for the ships' propulsion machinery was set at debarkation time, which was between H - 4 and H - 2 hr. For Shots 1 and 2, the timer was set for 23½ hr; for Shots 4 and 5, it was set for 12 hr on the unmanned YAG 40.

On Shot 1 both ships were retrieved by tugs and towed unmanned from Bikini to Eniwetok Lagoon. On Shots 2, 4, and 5, the YAG 39 was manned and brought back under her own power, while the YAG 40 was retrieved by a tug and towed from Bikini to Eniwetok.

1.5.1 Ships' Courses and Fallout Predictions. Selection of ships' courses was particularly difficult, because of four conditions which had to be met. First, it was considered desirable to accumulate an amount of activity on deck of the unprotected ship that amounted to a peak dose rate of between 300 to 1000 r/hr when extrapolated back to 1 hr. Positioning of the ships to obtain these levels depended on the wind structure, which generally changed considerably between successive soundings conducted at 3-hr intervals. Second, for optimum performance of the washdown system, a course heading generally into the surface winds was necessary. Third, the ships had to keep beyond the 1-psi air-blast overpressure range at the shot time. Fourth, during the unmanned runs, Task Group 7.3 insisted that the course not be directed toward any of the islands of the atoll.

Gamma intensity-time data from a station on YAG 40 were telemetered during each run, either to the aircraft during unmanned runs or to YAG 39 during manned runs. This information assisted control parties in determining course changes during the run. Records from this station located on No. 4 hatch are shown in Figure 1.2.

The range of peak dose rates needed to have as high contamination levels as possible without jeopardizing decontamination operations between shots is indicated by the decay lines in Figure 1.2.

Few useful results were obtained from Shot 1. While the ships

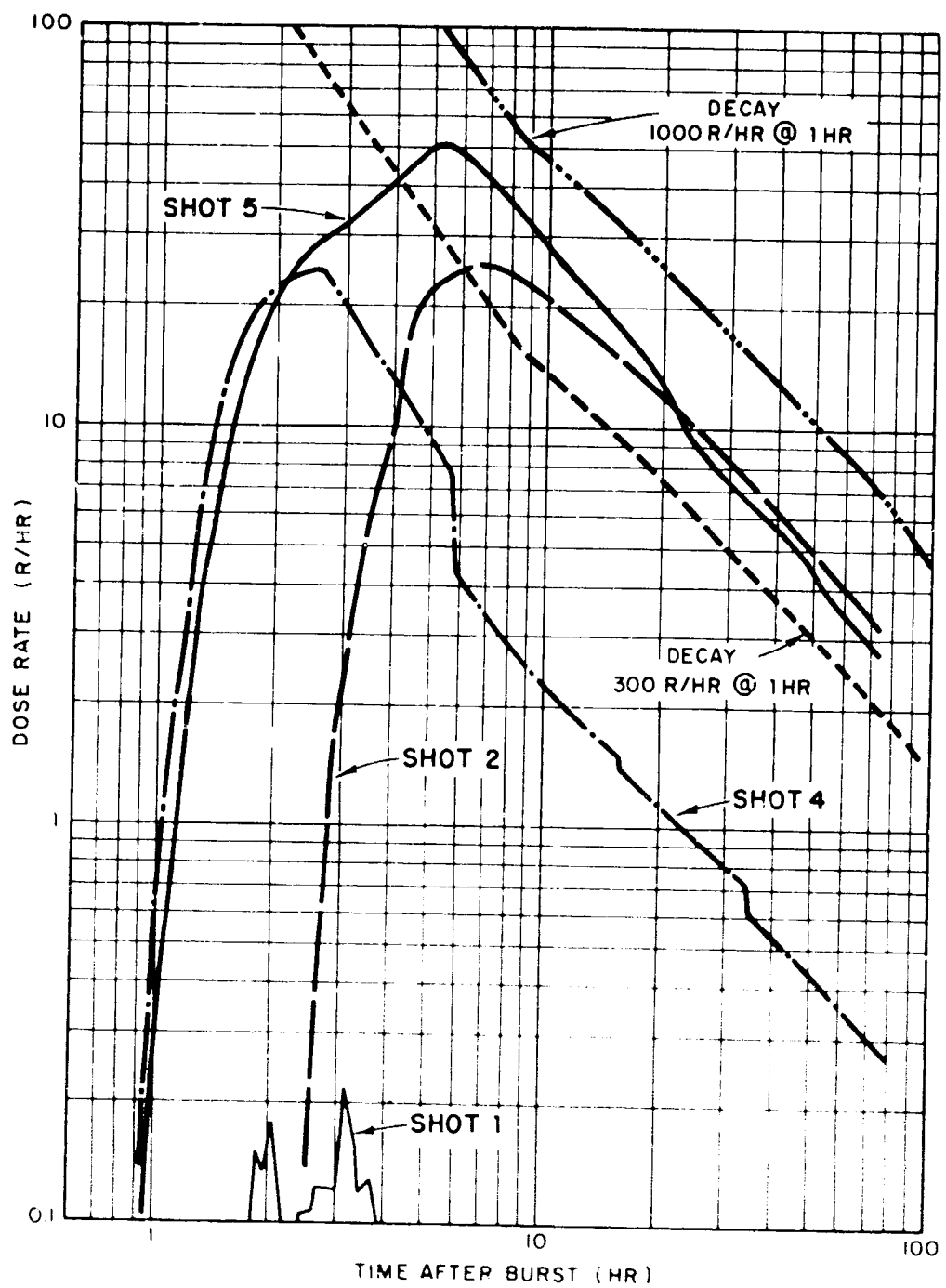

Figure 1.2 Gamma dose rates from telemetered station on YAG 40.

operated successfully, the course chosen resulted in very low levels of contamination. Although Shot 2 gave valuable data for most of the problems, the test was not completely successful, because of inadvertent failure of the control systems of the test ships. As a result, YAG 39

and YAG 40 did not follow the same course; hence, the fallout events were different for the two ships. Peak dose rate on YAG 40 was within the range of desired levels. Operations for Shot 4 were successful; both ships traversed the same course, within about 2,000 yd of each other. Although peak dose rates on YAG 40 were somewhat lower than desired, they were high enough to give useful data. Operations for Shot 5 were completely successful. Spacing between the vessels varied somewhat more than during Shot 4 but was generally within 3,000 yd. Peak dose rates on YAG 40 were within the desired range.

1.5.2 Shot 1 Operations. The course for Shot 1 was selected on the basis of forecast winds, particularly at the lower levels. These were generally easterly with shear toward westerlies with increasing height. A change toward more-westerly winds before shot time made the possibility of a successful run on the west side of the atoll dubious; however, there was insufficient time to change the ships' initial position. Planned and actual YAG tracks are shown in Figure 1.3, together with forecast and actual directions of the winds. Wind hodographs, as plotted, represent a line on the surface along which particles falling at 10,000 ft/hr would

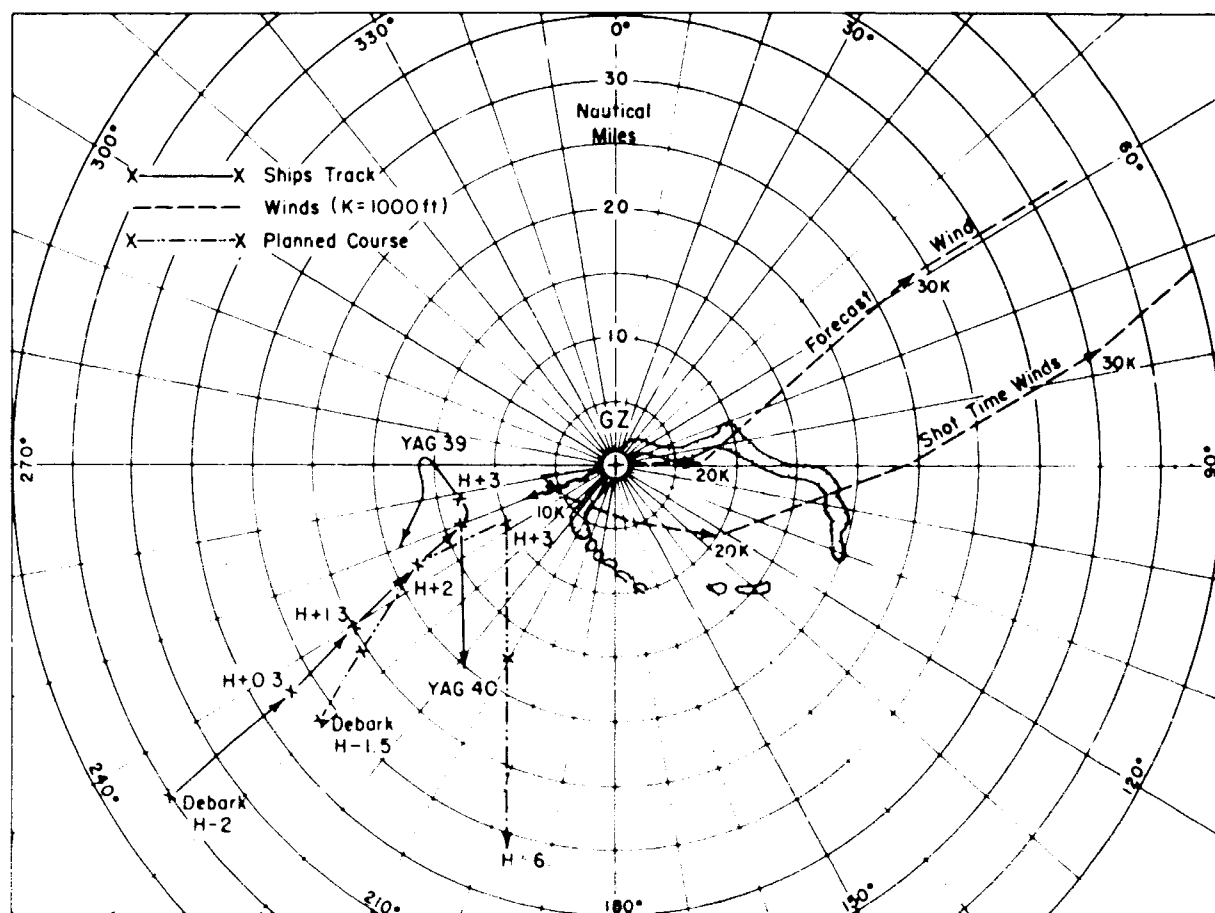

Figure 1.3 Ship's course - Shot 1.

land starting from the indicated heights above ground zero. Particles falling at other rates, from a given height, lie along radial lines drawn from ground zero through the given elevation on the hodograph. From Figure 1.3, it is apparent that the fallout pattern lies almost

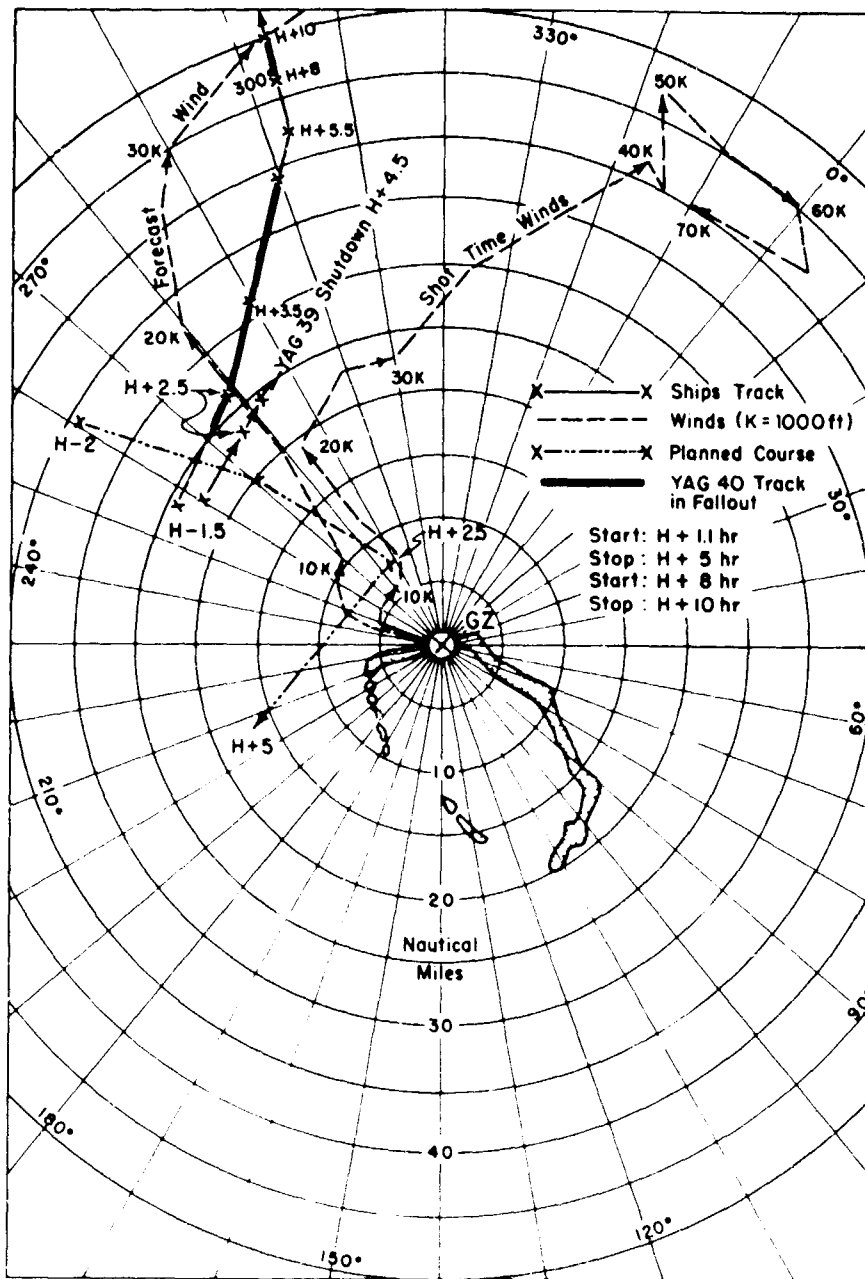

Figure 1.4 Ship's course - Shot 2.

entirely to the east of the shot point and mainly to the south of the hodograph.

1.5.3 Shot 2 Operations. As the result of Shot 1 fallout data, the course for Shot 2 was selected on the basis of forecast winds at levels in the vicinity of 30,000 ft. The actual tracks of the ships, together with forecast and observed directions of the winds, are shown in Figure 1.4. The proposed course was  $80^{\circ}$ , but because of an operator's error which occurred prior to debarking, it was impossible to turn YAG 40. It was decided to keep the YAG 39 with the YAG 40; but this attempt failed, because of a malfunction of radio-control apparatus which converted a speed change to a shutdown signal on YAG 39. Experience on this and the previous test indicated that a successful run, with ships operating as close together as possible, would be difficult to achieve with primary control aboard the aircraft. Dosage time histories obtained from this test indicated that the YAG 39 could be safely manned, even for a much



more highly contaminating event because of the washdown system and because of the very effective shielding provided by the 12-in. concrete slab protecting the instrument recording room, to which personnel could retire. Accordingly, primary control was shifted to YAG 39 during subsequent runs.

1.5.4 Shot 4 Operations. Operations were conducted to the east of the atoll with a course toward the shot point immediately after H hour to an initial position for Shot 4. Instead of using 30,000-ft wind data to select a course for Shot 4, the following procedure was used. Shot-time distance was selected on the basis of blast overpressure and the bearing, on the basis of forecast winds and wind soundings. The winds were used to estimate the sector in which fallout from elevations corresponding to the lower part of the mushroom would occur. Within this sector arrival times for particles of various sizes falling from these elevations were estimated. As nearly as practicable, a run was then

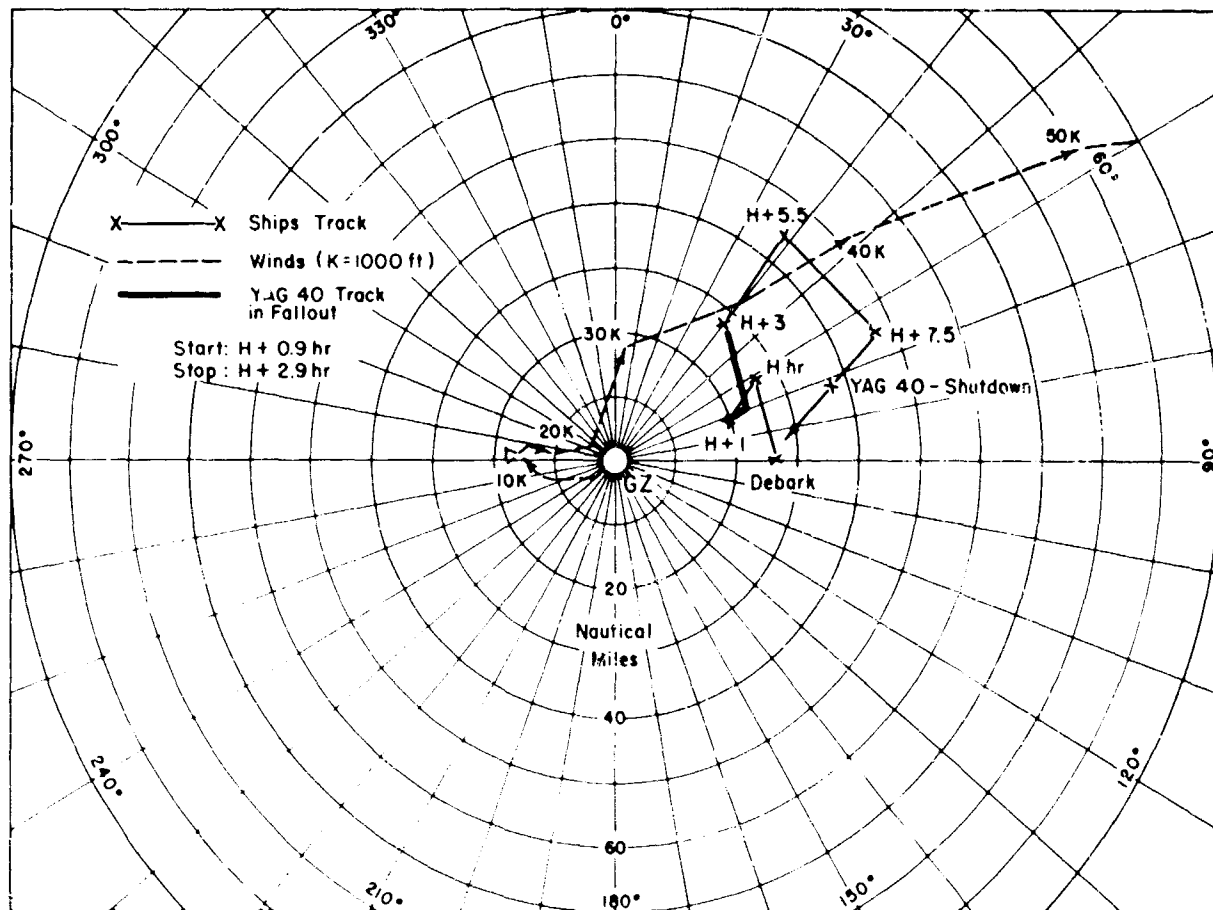

Figure 1.5 Ship's course - Shot 4.

chosen such that the ships would intersect the sector at the onset of fallout and that the rate of advance of fallout along the run would approximately equal the ships' speed. In this way the ships were expected to remain within the probable region of fallout for the maximum time. Ships' courses which were generally in a northeasterly direction and shot-time wind soundings are shown in Figure 1.5. Because of an incorrect position report from the aircraft, instructions given to YAG 39 resulted in a more northerly course during the first 3 hr than anticipated. Wind soundings made at H + 3 hr indicated a considerable shift of the wind pattern toward the south; accordingly, when these data

had been received, a course change toward the southeast was instituted at about  $H + 5\frac{1}{2}$  hr. This course was intended to intercept some possible late fallout at about 8 hr.

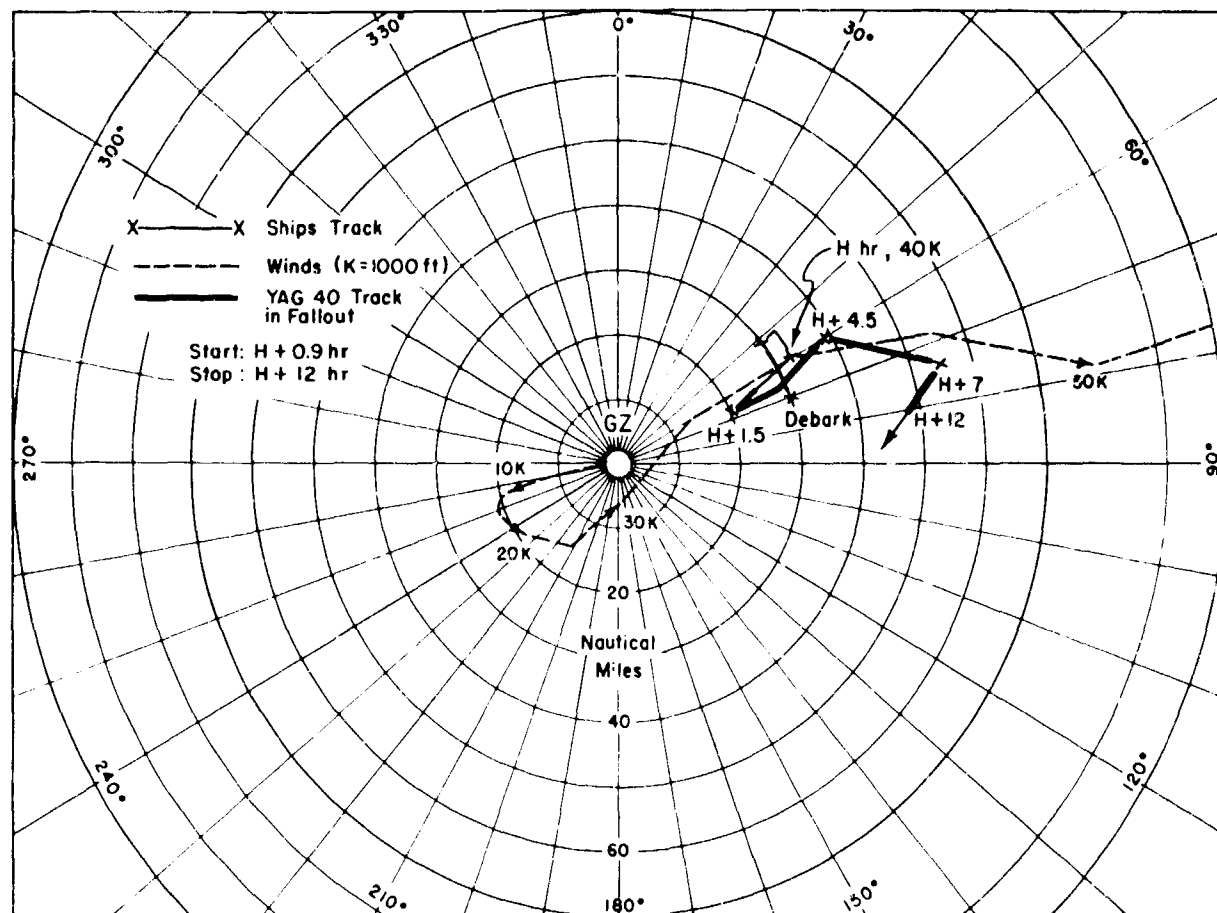

Figure 1.6 Ship's course - Shot 5

**1.5.5 Shot 5 Operations.** Operations for this test were similar to those for Shot 4. Ships' courses and shot-time wind pattern are shown in Figure 1.6.

#### 1.6 THE CONTAMINATING EVENT ALONG THE SHIPS' TRACKS

The heavy line shown on the course of the YAG 40, Figures 1.4, 1.5 and 1.6, gives the best estimate of the ships' location during fallout. The legend gives the time of start of fallout (accumulation of first 0.1  $\mu$ r measured 3 ft above the deck) and its end as estimated from a decay-corrected plot of masthead intensity time recordings.

The periods shown are the total times of the principal fallouts.

During these periods the recorded intensity-time curves from both ships when corrected for decay show irregular increases in intensity. These irregularities indicate that the fallout on the ships was neither continuous nor of uniform intensity and may have ceased several times during the periods given. Air sampling results aboard ship indicated similar irregularities.

**1.6.1 Gross Description of Fallout Aboard Ships.** Limited observations from a helicopter during Shot 2 fallout and from the deck of YAG 39

during Shot 4 fallout as well as fragmentary data from fallout photography and air sampling indicate that the fallout was not visible as a mist or fog and that it had a very low particle concentration.

In Shots 4 and 5, no visible deposits of material were found on the test ships; in Shot 2, the aircraft on YAG 40 carried uneven patches of a chalky substance on its windward surfaces. This chalky substance was associated with the highest intensities found in the post-shot aircraft survey and was readily removed by non-destructive decontamination methods.

1.6.2 Maximum Accumulated Dosage. Accumulated dosage for times up to 50 hr is presented in Figure 1.7 for the YAGs, Shot 5, when maximum intensities were encountered aboard the test ships.

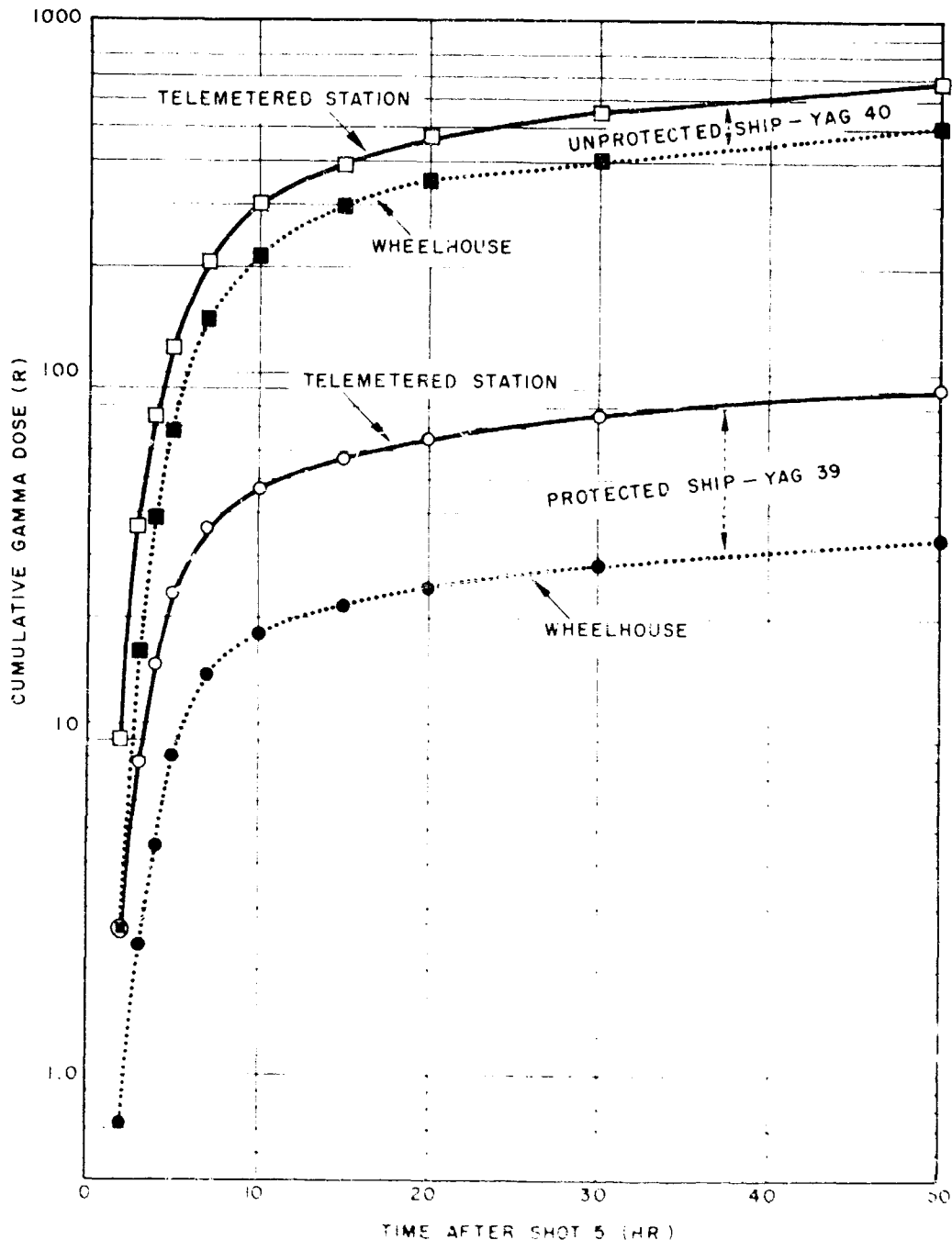

Figure 1.7 Accumulated dosage for YAG 39 and YAG 40 after Shot 5.

The significance of these dosage figures in terms of medical effects will not be discussed in this report. They are presented simply to show that a significant gamma radiation hazard existed and that protection for personnel is required.

The YAG 40 telemetered station data are representative of the average of dose data from the various topside weather areas; the wheelhouse station data are given to show the accumulated dose at an important duty station in a lightly shielded area. Similar curves for YAG 39 (adjusted for fallout differences due to the separation of the courses of the two ships) are presented for direct comparison. The area surrounding the telemetered station on YAG 39 was the most poorly washed on the ship.

1.6.3 Decay. Decay curves were derived from information received from Projects 2.5a and 2.6a. Figure 1.8 shows the gross gamma ionization

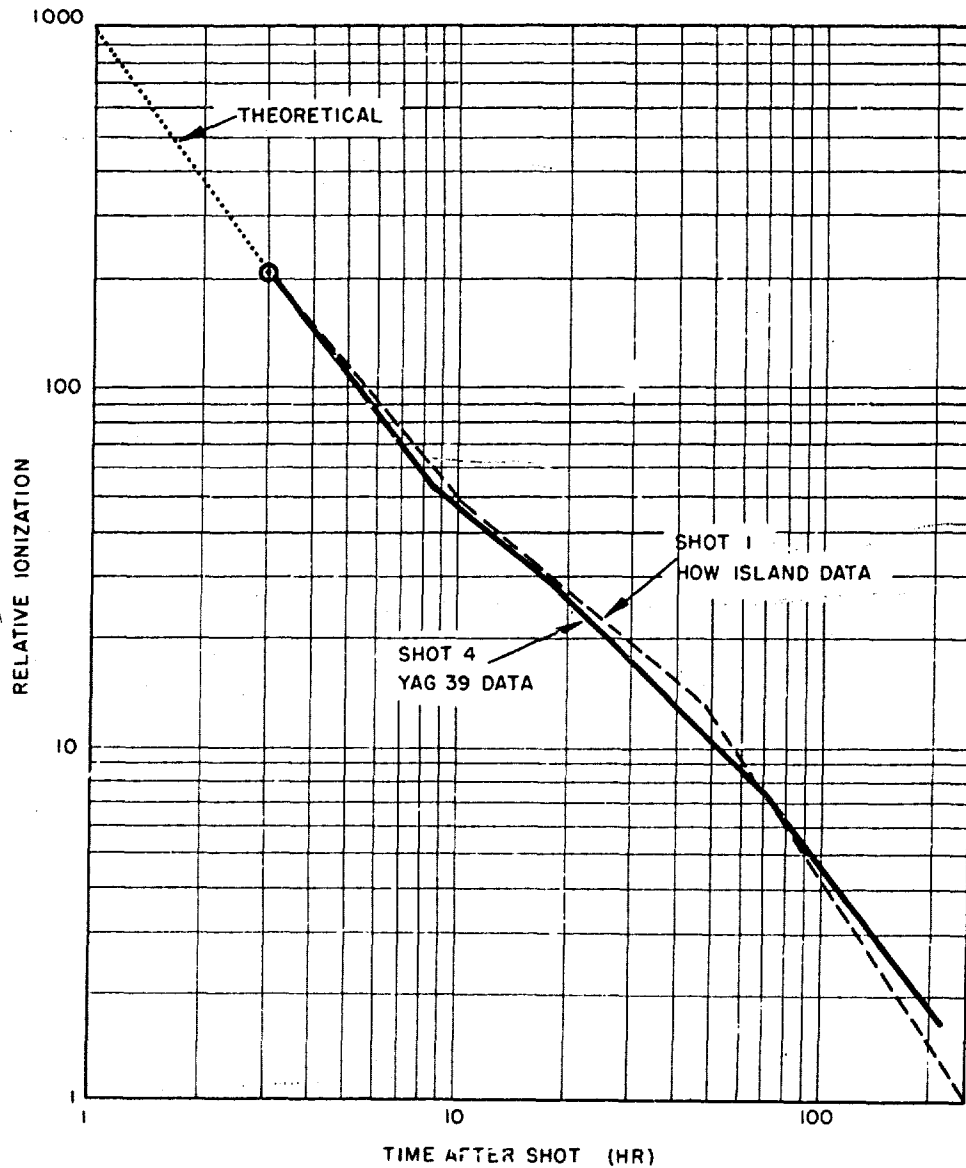

Figure 1.8 Gamma ionization decay curve, Operation Castle, based on information from Projects 2.5a and 2.6a.

decay curves used in some sections of this report. Other groups used decay curves derived from their own data.

Beta ionization decay curves were also derived from information received from Projects 2.5a and 2.6a. The beta decay curve,  $R = R_0 t^{-1.4}$ , has been used throughout the report for the period after 3 days.

Disintegration decay rates derived from information from Projects 2.5a and 2.6a were used in the interior contamination studies.

## 1.7 PLAN OF FINAL REPORT FOR PROJECT 6.4

Discussion of the nine problems into which the objective of Project 6.4 was divided constitutes the subsequent chapters of this report. Each individual responsible for the work on a particular problem (See Figure 1.1) has written his chapter as a complete report. At the beginning of each chapter, its salient features are set forth in an abstract. The bulk of raw data in most cases prevented its inclusion in the report. Selected data and summaries are presented where applicable and complete field data are on file at HRDL.

1.7.1 Limitations of the Report. The fallout region of military interest is defined as that area beyond immobilizing shock ranges where incapacitating or serious radiation hazards exist. The ships' travel through this region represents only a small fraction of the contaminated area of military interest, and data from these tests are directly applicable only to the unique set of conditions existing along the ships' line of travel. Extrapolation of test results to other conditions or contaminating events and detailed application to combatant ship situations must await further study and correlation with data from other projects, other weapon tests, and laboratory work.

## Chapter 2

# SHIP - WASHDOWN COUNTERMEASURES

H. R. Rinnert

Two remotely controlled ships, one of which was protected by a washdown countermeasure and both of which had special structural configurations to simulate typical contaminant-collection surfaces, were guided through regions of contaminated fallout to determine the effectiveness of a washdown countermeasure aboard a ship caught in a contaminating event of the type encountered at Operation Castle. Recording gamma-radiation detectors and postshot radiation surveys supplied data on the resulting radiation fields at various locations aboard ship.

The data showed that gamma radiation doses of 300 r could have been received within 10 hr after burst by personnel at exposed locations. The washdown countermeasure was found to cause a 87 to 94 percent reduction of accumulated gamma dose and a 90 to 96 percent reduction of gamma radiation field at exposed locations by the time the fallout ended. Subsequent washing for 2 hr increased only these reductions to 89 to 95 percent for dose and 93 to 97 percent for dose rate. The transit dose was estimated to have minor significance on an unprotected ship for this type of event. The washdown effectiveness was found to adversely influenced by poor drainage, low flow rates, and by lack of maneuvering when the wind was abeam.

The washdown countermeasure had a high effectiveness against fallout of the type encountered during these tests, but it should also be field tested for effectiveness against other types of contaminating events, such as base surges. The possibility that washdown may cause significant increases in radiation fields from high-capacity boiler systems merits investigation.

### 2.1 BACKGROUND AND THEORY

Laboratory tests and ship trials (References 1, 2, 3) using simulants, have indicated that a semi-automatic washdown of the ship's weather surfaces is a rapid and effective means of reducing the radiation hazard to personnel during and after a contaminating attack.

During a contaminating event, several sources contribute to the gamma radiation intensity level at any particular location aboard ship. These sources are the contaminant: (1) actually on the weather surfaces; (2) in the air envelope surrounding the ship; (3) dispersed in the water envelope surrounding the ship; and (4) passing through or settling out in the ventilation and boiler air systems. The relative contributions to the overall intensity level at any point will depend upon the strength of the individual sources and the attenuation afforded by

intervening structures and distance. It was expected that the washdown would be effective only against that contaminant actually on the weather surfaces. Therefore, even if the washdown entirely removed or prevented the accumulation of contaminant on weather surfaces, it was still possible to have a significant radiation intensity at various locations aboard ship. Tests performed with simulants had considered only effects upon some types of surface contaminants. Therefore, proof-testing during an actual contaminating event was required to evaluate the washdown performance in terms of reduction in radiation dosage from all sources of contamination.

The gamma radiation fields and integrated doses were studied as a function of time to give a better understanding of washdown action. The washdown was expected to suppress the buildup of contaminant on the ship's weather surfaces during the event. Following the ship's emergence from the contaminating event, the effect was expected to approach a limiting value, indicating that further washdown would serve no practical purpose. A hypothetical case for gamma dose rates on the deck of a ship caught in radioactive fallout is illustrated in Figure 2.1. A similar figure could be presented for integrated gamma doses.

The percentage reduction in integrated dose at any time is a measure

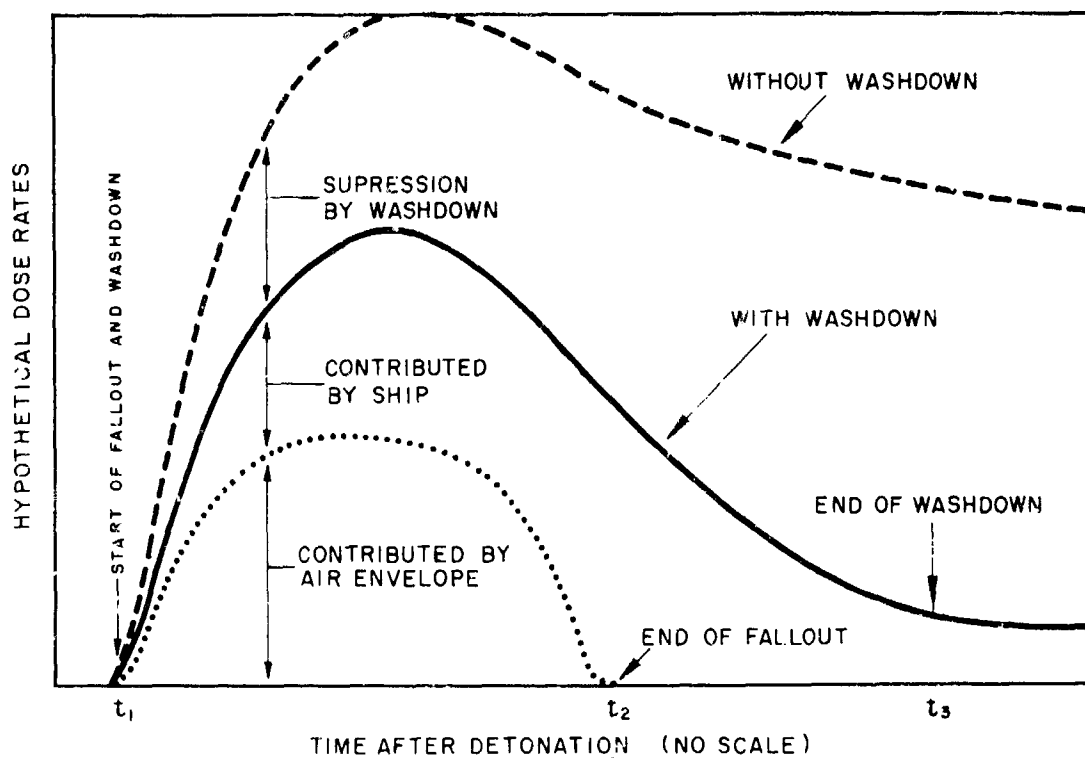

Figure 2.1 Hypothetical gamma dose rates on deck of ship caught in radioactive fallout from a nuclear weapon.

of the washdown effectiveness with respect to the total whole-body gamma-radiation dose already received by personnel at the given location.

Use of the percentage reduction in dose rate as a measure of washdown effectiveness results in somewhat different interpretations at various times. After the end of washdown and of fallout (i.e., later than  $t_3$ , Figure 2.1), the ratio of dose rates is equal to the ratio of doses yet

to be accumulated, if it is assumed that the decay is unaffected by the washdown; therefore, the effectiveness based upon dose rate is equal to the effectiveness with respect to future gamma radiation dose expected at that location. After the end of fallout (i.e., later than  $t_2$ ), the ratio of dose rates approximates the ratio of amounts of contaminant on the ship's weather surfaces; therefore, during this period the effectiveness based upon dose rates is a measure of effectiveness with respect to physical removal of contaminants from the weather surfaces and permits correlation with prior tests in which simulants had been used. During the fallout (i.e., prior to  $t_2$ ), no special interpretation exists, the effectiveness with respect to dose rates simply is a measure of the suppression of radiation fields set up by any and all sources of gamma radiation.

To have a basis for evaluation of the washdown effect, two ships with similar configurations and surfaces, one protected by an installed washdown system, were instrumented alike and sent through the contaminating event as close together as possible. The initial assumption of equal fallout on the two ships was investigated by means of instrumentation atop the forward kingpost on each ship (see Appendix A for details). Determination of effectiveness required that the two ships have equal dose rates and equal accumulated doses at any given time, assuming that neither ship had been washed. Where this requirement was not met, data were adjusted to account for the differences.

## 2.2 OBJECTIVE

The problem of evaluating washdown countermeasures on ships caught in a radioactive contaminating event like that encountered at Operation Castle was divided into four subordinate tasks. These were: (1) investigation of the relative magnitude of radioactive fallout on the two test ships; (2) determination of the gamma radiation dose rates and integrated doses at different times for comparable locations aboard the test ships; (3) utilization of this information to determine the effectiveness of the washdown system in terms of the reduction of the integrated gamma radiation doses and the reduction of the gamma radiation fields at various times after detonation and at locations simulating configurations and surfaces typical of combatant ships; and (4) determination of the influence of the distribution of the washdown water, the relative speed and direction of the wind, and the maneuvers of the test ships upon the washdown effectiveness.

## 2.3 INSTRUMENTATION

Details of the washdown and drainage systems are given in this section, together with the location of the stations for recording gamma intensity-time data. No description of the construction and circuitry of the gamma detectors and recording system is given, since this material is covered in Chapter 8.

2.3.1 Washdown System. Three 1000-gpm pumps took sea-water suction at a depth of approximately 20 ft below the waterline and fed a main piping loop located on the main deck. Smaller pipes extended from this



main loop and ran to various portions of the decks and superstructure, where they terminated in spray nozzles. The locations of the nozzles were determined by a cut-and-try process which resulted in a fair visual water coverage of the weather surfaces (Figure 2.2). Some areas were covered better than others to permit study of the dependence of washdown effectiveness upon flow rate. The flush-deck nozzle used in the flight deck is shown in Figure 2.3. The spray nozzle used elsewhere is shown in Figure 2.4.

The flow rate was recorded by means of a disc-type electri-contact water meter installed in a bypass of the main water-supply line. The electri-contact meter closed and broke an electrical circuit whenever a given quantity of water had passed through it. The electrical pulse was recorded as a blip on paper running at constant speed. This record permitted determination of quantity and flow rate of water as a function of time.

2.3.2 Drainage Systems. The flight deck, boat deck, and after part of the top of the house were each surrounded by drainage troughs designed to catch all surface runoff, which was gravity fed to individual measuring systems located in the holds. These systems consisted of strainers and disc-type electri-contact water meters which fed water into vented float chambers, which in turn were drained by centrifugal pumps. The float in the chamber actuated a proportioning valve, which permitted the pump to take sea suction to the extent that it was under constant load without affecting the gravity feed of drainage water to the meter. The schematic arrangement is shown in Figure 2.5.

2.3.3 Recording Gamma Radiation Detector Stations. All gamma-radiation detector stations were able to measure intensity levels ranging between 15 mr/hr and 360 r/hr. Some stations could detect intensities as low as 0.15 mr/hr; others could detect intensities as high as 36,000 r/hr.

The general locations of the various detector stations for washdown evaluation are indicated in Figures 2.6 and 2.7. All weatherside detector stations and their associated shielding were covered with plastic or aluminum domes extending to the surface on which they were located. The domes had an integral washing system installed in order to minimize the undesired buildup of contaminant on their surfaces. Flow rates were of the order of 6 gpm per dome. On the YAG 40, this dome wash water was caught in troughs, installed around the bases of the domes, and led overboard by interior drainage systems. This was done to prevent the water from disturbing the contaminant on the ship's weather surfaces. On the YAG 39, the dome wash water was allowed to run off on the decks, because the flow rate was negligible compared to that of the ship's washdown system on any area.

Stations in the fireroom were enclosed in copper jackets which had cooling water coils installed to keep the temperature below the point at which damage to detectors and their circuits would occur.

Station 10, on top of the forward kingpost of each ship, was enclosed in a 2-in.-thick lead cylinder open only at the top. The adjacent Station 9 on each kingpost was unshielded.

Stations 45 and 46, on top of the house, were shielded from radiation originating at the stack and the forward part of the top of the house by lead 2 in. thick.



Figure 2.2 Washdown of ship.

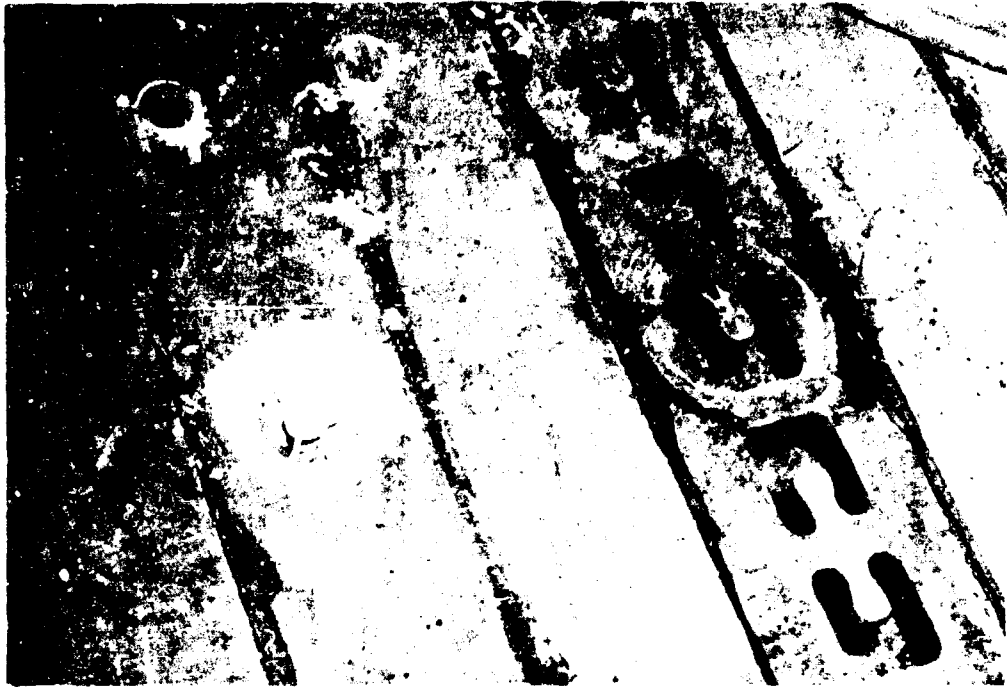

Figure 2.3 Flushdeck nozzle.



Figure 2.4 Spray nozzle.

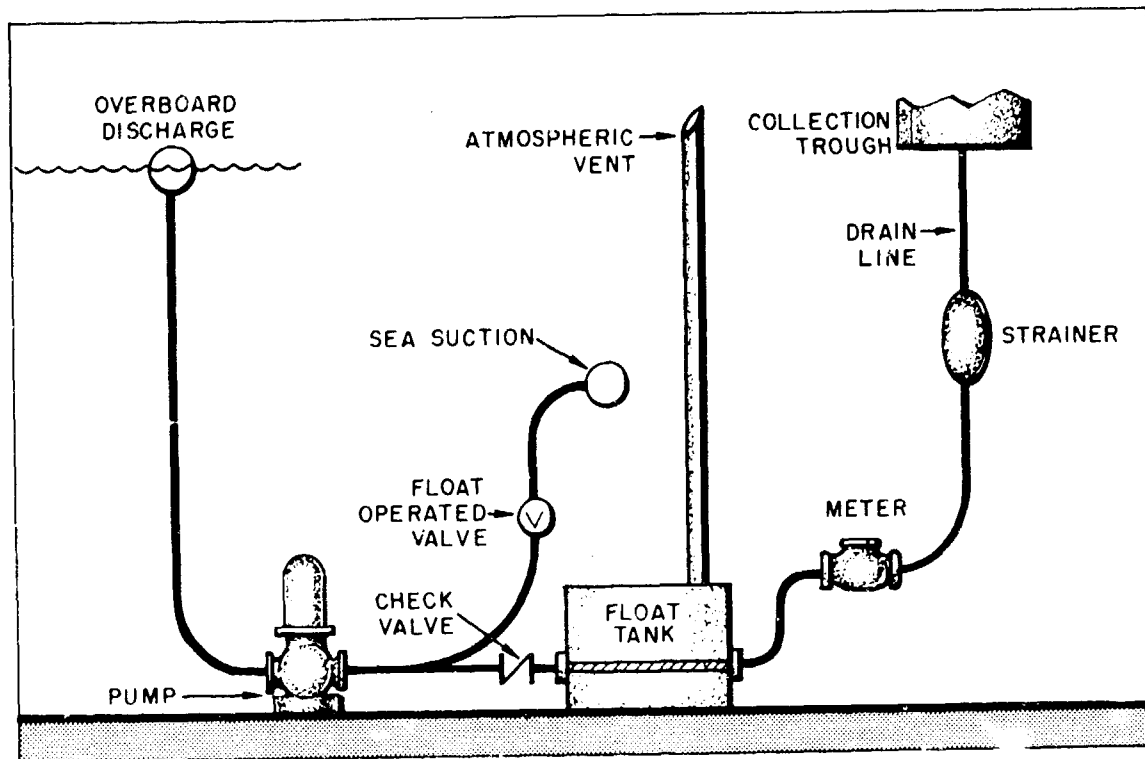

Figure 2.5 Schematic drain-meter installation.

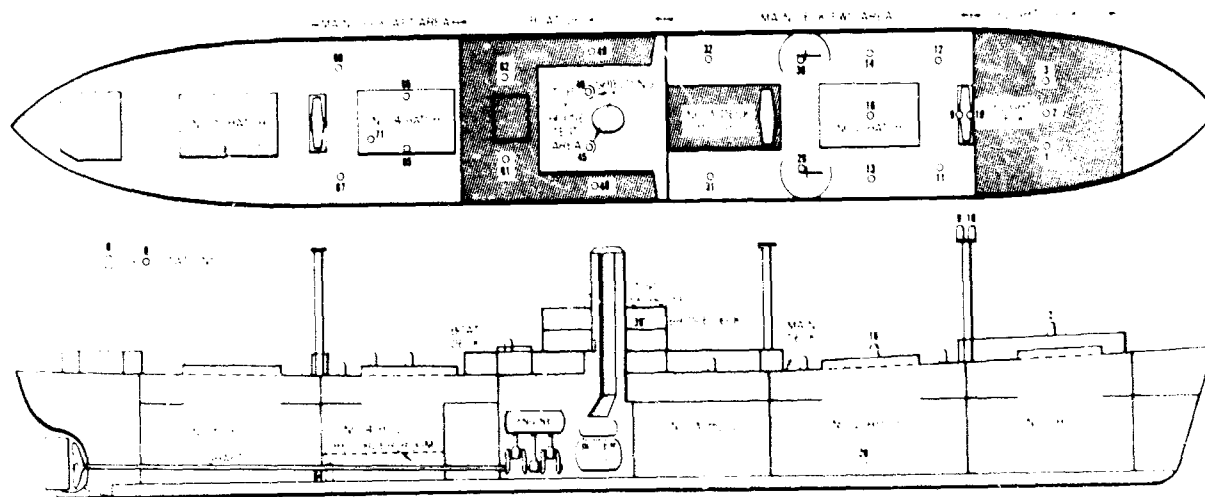
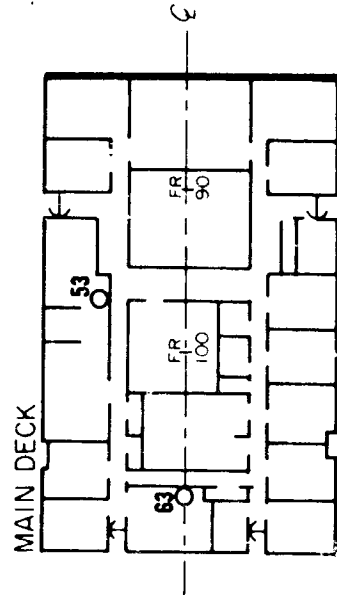
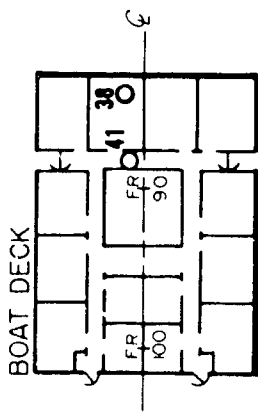
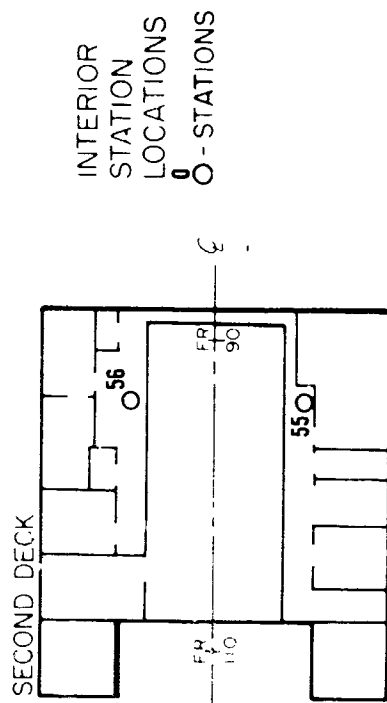
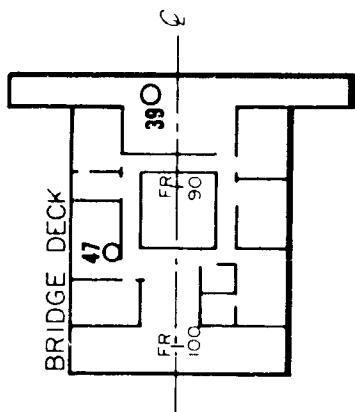
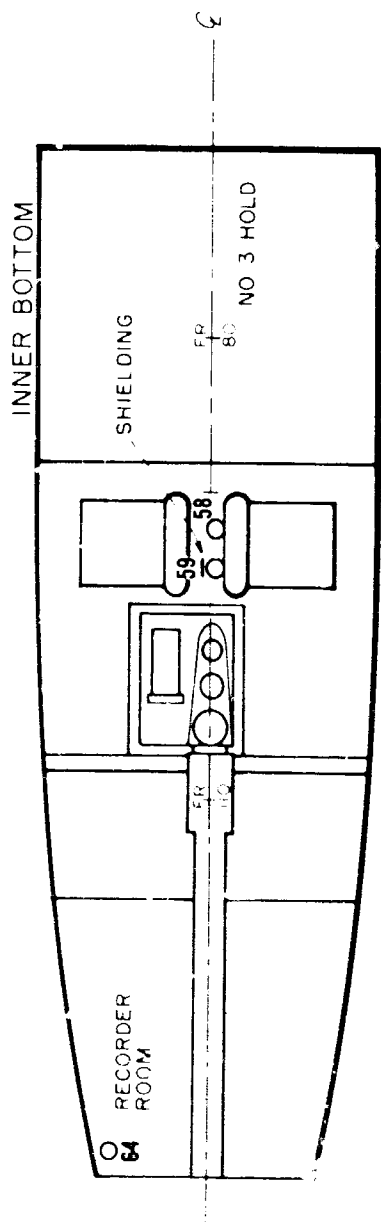

Figure 2.6 General location of detector stations.



INTERIOR  
STATION  
LOCATIONS  
○ O - STATIONS

Figure 2.7 General locations of detector stations.

Stations 55 and 56, which were adjacent to the fireroom casing on the second deck, were shielded from the boilers by steel 3 in. thick which simulated an armored deck.

Station 59, close to the starboard boiler and in the firing aisle, was shielded from the port boiler and from overhead by 2 in. of lead. Adjacent Station 58 was unshielded.

Station 64 was located in the recorder room, which was shielded from the weather surfaces by 12-in. thick concrete and several deck thicknesses of steel. Station 64 was equipped with a dome washing system similar to those on weatherside stations but had an intermittent washing action controlled by a timer to permit determination of radiation contribution from the dome wash water.

With few exceptions, the geometrical centers of the sensitive volumes of the radiation detectors pertinent to this chapter were 3 ft above the surfaces on which they were located. Stations 9 and 10 were as close to the masthead surface as was practical, Stations 55 and 56 were about 1 ft above the second deck, and station 28 was about 6 ft above the bottom of No. 2 hold.

2.3.4 Recording Wind-Velocity Indicator. A standard Naval wind direction-and-intensity indicating system was installed on the second kingpost of each ship. The associated recording unit was placed in the between-deck recorder area of No. 3 hold.

## 2.4 OPERATIONS

The dome wash system and the recorders for water flow, wind velocities, and gamma radiation were readied and set into operation several hours before detonation of the nuclear weapon. This was accomplished by the personnel of the Instrument and Interior Contamination groups, who cooperated to keep the special test crew to a minimum. Crew members of the YAG 39 readied the washdown system and started the pumps prior to detonation time. The water was pumped over the side until the telemetering station indicated that the test ships were entering the radioactive-fallout area, at which time the water was fed to the washdown system. The washdown continued for several hours past the time of estimated cessation of fallout as indicated by the telemetering station.

After the test ships had returned to their anchorage and as soon as radiation safety permitted, the personnel of the Instrument Group retrieved the records, and reloaded and restarted the radiation recorders to provide a continuous history of the gamma radiation aboard the test ships. Reduction of the recorded data was begun immediately. As soon as conditions permitted, the instrumentation and washdown system were readied for participation in the following shot.

## 2.5 RESULTS AND DISCUSSION

Although the test ships participated in four shots, only Shots 4 and 5 yielded significant washdown-effectiveness data.

During Shot 1, the two ships were barely contaminated. The ships were widely separated during Shot 2 and received radically different

amounts of fallout; consequently, no direct comparison could be made. Preliminary estimates, based upon insufficient data, gave a washdown effectiveness with respect to dose rate of about 70 percent for Shot 1 and of greater than 90 percent for Shot 2. Lack of confidence in the data discouraged spending more time on evaluating washdown effectiveness for Shots 1 and 2.

2.5.1 Relative Magnitude of Fallout on the Test Ships. In the initial planning of the test, it was assumed that the two test ships would receive similar fallout because of the size of the contaminating event and the proximity of the ships. During test operations, it was realized that the two ships could not operate as close together as planned and some of the dose rate data from the kingpost stations indicated the probability of different amounts of fallout having been received on the two ships. The kingpost stations had been set up originally to estimate the radiological effects from the contaminants in the air envelope surrounding the ship. Data from these kingpost stations were found to serve for estimating differences in fallout by the technique described in Appendix A.

It was estimated that the two ships received similar amounts of fallout for Shot 4.

For Shot 5, the estimates for the effects of dissimilar fallout are presented in Figure 2.8.

Since the two ships were some distance apart, there were differences

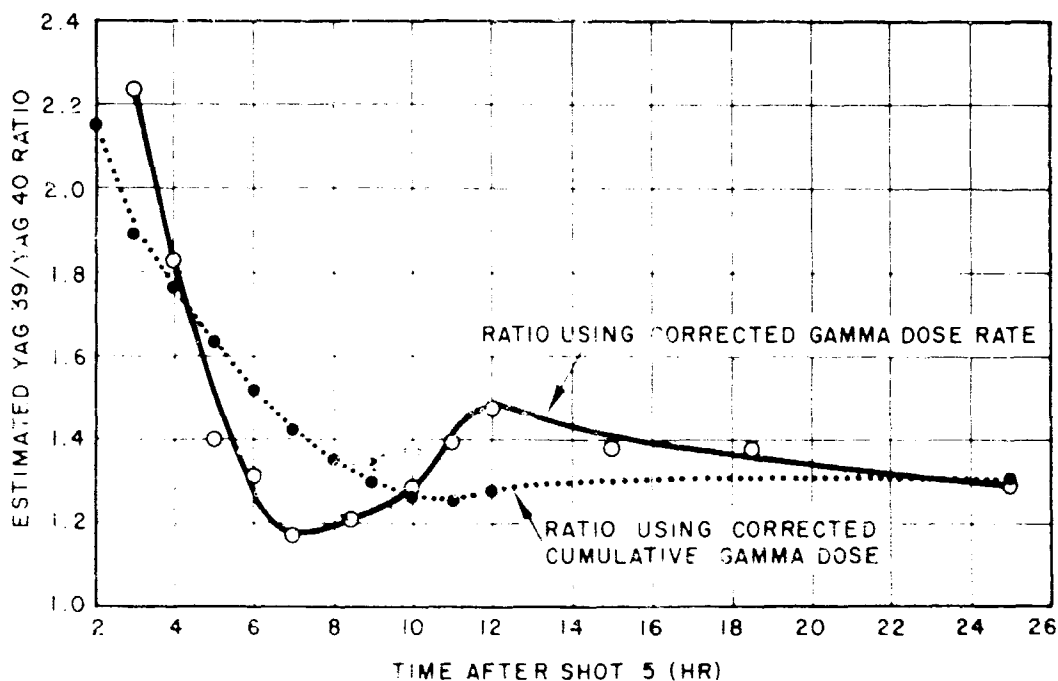

Figure 2.8 Estimated YAG 39/YAG 40 ratio of fallout effects as a function of time after Shot 5, based on shielded masthead stations.

in the rates and times of arrival of fallout. Because dose is cumulative and dose rate is instantaneous, the ratios of fallout effect based upon dose and those based upon dose rate were not identical at any given time.

The dose and dose rate data of YAG 39 were divided by the pertinent ratios in Figure 2.8 to adjust the data to the point where the two ships

could be considered to have received similar fallout. The unadjusted data for YAG 39 are tabulated in Appendix A.

2.5.2 Periods of Fallout and Estimate of Transit Dose. Figure 2.9 shows the data from the masthead station that were mainly affected by the

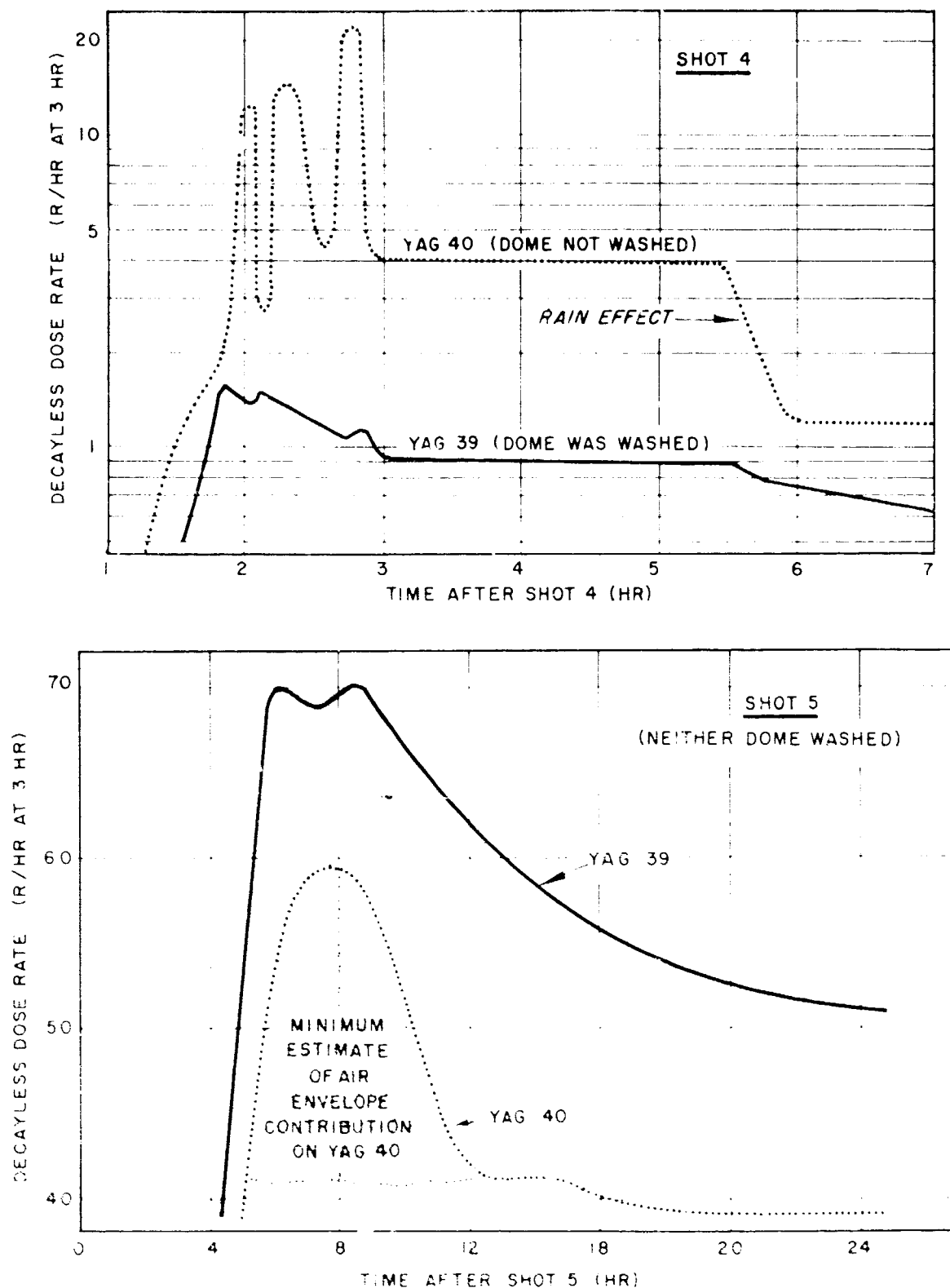

Figure 2.9 Shielded station dose rates, with deck contributions subtracted and corrected for decay using 3 hr after shot as base time.



contaminant on the station dome and in the air envelope. These data were corrected for decay, using the decay curve in Figure 1.8, and were also corrected for the contributions from the deck areas. No adjustment for differences in fallout was made in this case. Figure 2.9 is useful for estimating periods of fallout on the two ships.

The start of fallout (not deducible from this figure), occurred at approximately 0.85 hr after shot time for both Shots 4 and 5.

During Shot 4, the figure indicates several distinct periods of fallout, the last of which ends 3 hr after shot time. The magnitudes of the peaks on the YAG 40 curve are in doubt, but the fact that the peaks occurred is undisputed. Because the masthead station domes were washed only on YAG 39, a direct comparison of magnitude of fallout effects is impractical. Note the effect of rain which occurred at approximately 5.5 hr after Shot 4. Because the rain removed contaminant from the surfaces of the two ships, the presentation of data and effectiveness for Shot 4 has been limited to the first 5 hr after burst.

During Shot 5, the masthead stations did receive similar dome-wash treatment; therefore, the differences observed in Figure 2.9 should be due to differences in fallout. Apparently, the magnitudes and durations of fallout differ on the two ships. The estimated end of fallout on YAG 40 was at 12 hr after shot time, whereas the fallout appears to have continued for some time after this on YAG 39. Because the washdown was turned off at approximately 11 hr after shot time, i.e., before the estimated end of fallout, the presentation of data and effectiveness has been limited to the first 11 or 12 hr after burst for Shot 5.

Figure 2.9 has another feature which may be of interest. Looking at the YAG 40 curve of Shot 5 as an example, it should be noted that the ordinates of the shaded area represent minimum estimates of the decay-corrected dose-rate contribution of the contaminant in the air envelope at the station. Lack of time and lack of knowledge of the shape of the curve of contaminant buildup on the masthead dome prior to end of fallout prevents rigorous estimation of the "transit dose," i.e., the dose due to contaminants in the air envelope. A crude estimate may be obtained by putting decay back into the ordinates of the shaded area and performing a numerical integration. For what they are worth, the crude results were doses at least greater than 0.8 r at 3 hr after Shot 4 on YAG 39 and doses greater than 23 r at 12 hr after Shot 5. Taking estimated differences in geometry into account, these figures lead to an estimate that as much as half of the dose accumulated on the weather decks of the washdown protected ship at the end of fallout may be due to the transit dose. Consequently, the washdown based upon reduction in gamma doses will always be less than 100 percent, even if all contaminants are kept from the weather surfaces. Washdown effectiveness values based upon reductions in dose were always less than effectiveness based upon reductions in dose rate; compare Figure 2.22 with Figure 2.24 and compare Figure 2.23 with Figure 2.25.

2.5.3 Gamma Dose and Gamma Dose Rates. The adjusted dose and dose rate averages for exterior areas are shown in Figures 2.10 through 2.13. Arithmetic averages were used in all cases. The data for individual stations are shown in Tables A.1 through A.12, Appendix A. As early as 10 hr after burst on Shot 5, the average dose received at exposed loca-

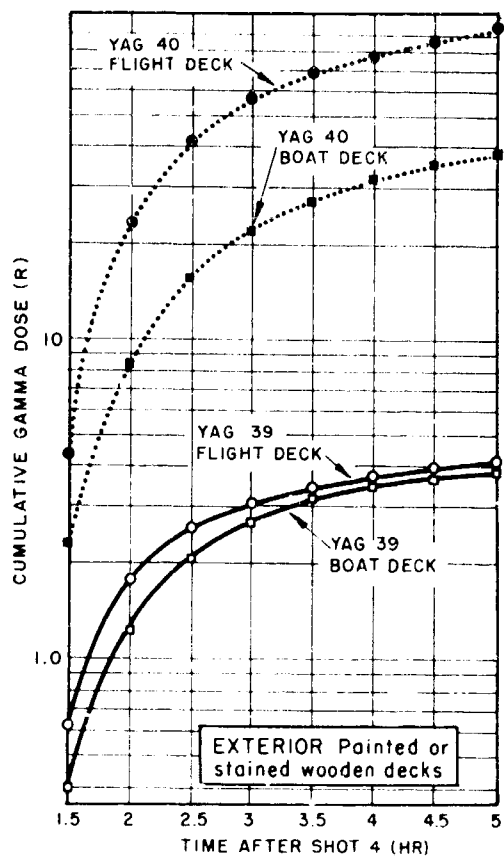
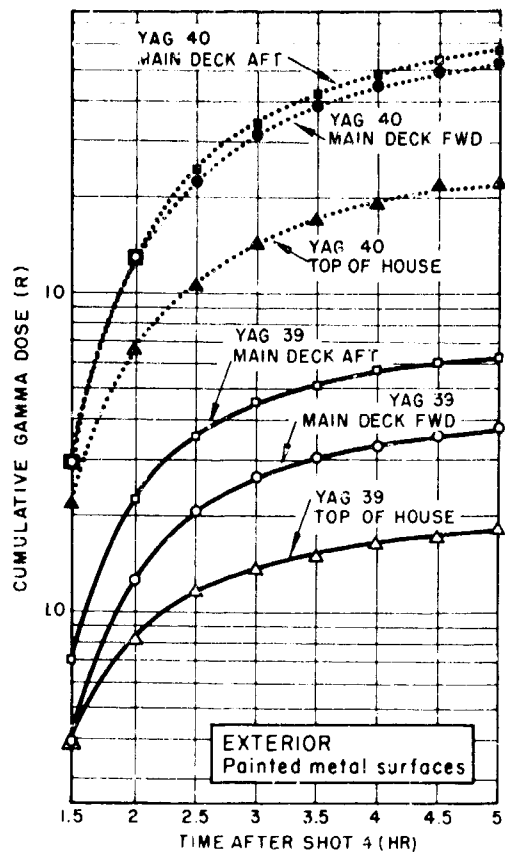

Figure 2.10 Cumulative gamma dose averages for some exterior areas vs time after Shot 4.

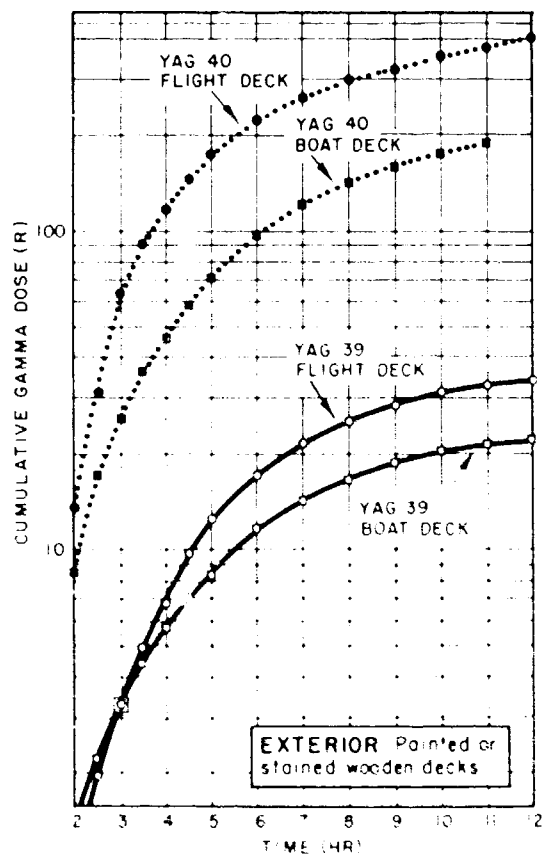
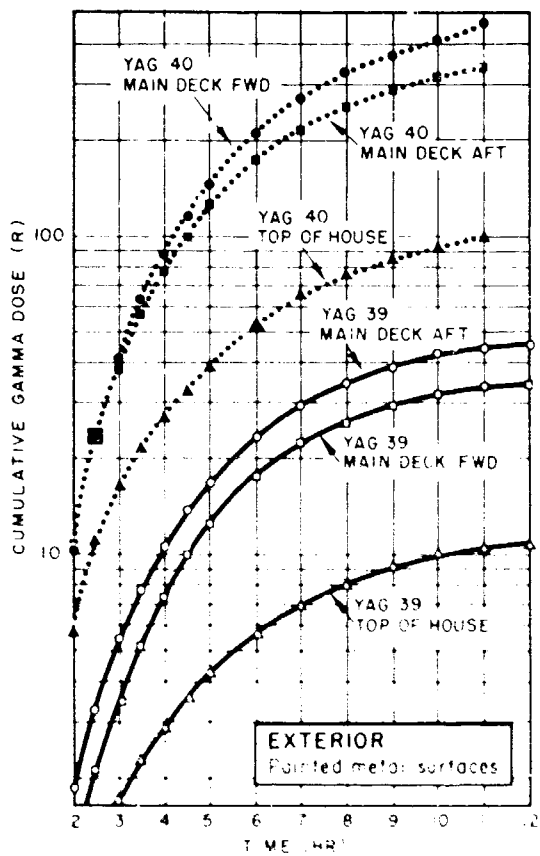

Figure 2.11 Cumulative gamma dose averages for some exterior areas vs time after Shot 5.

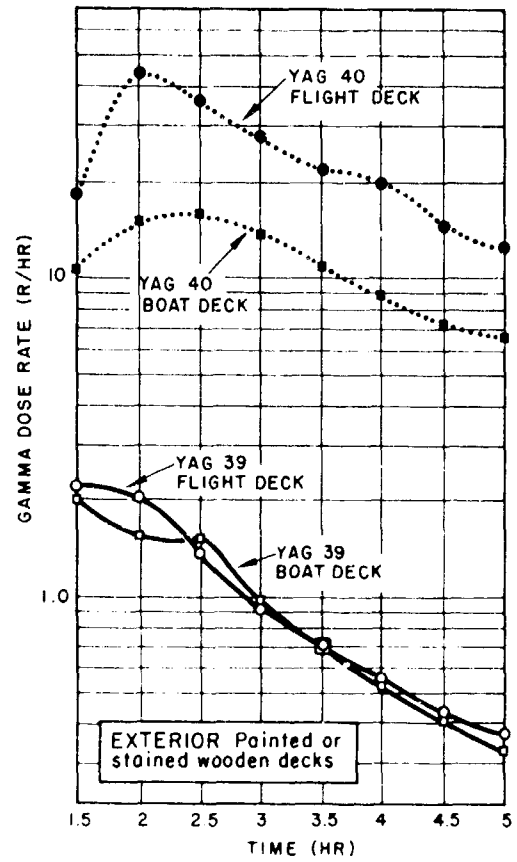
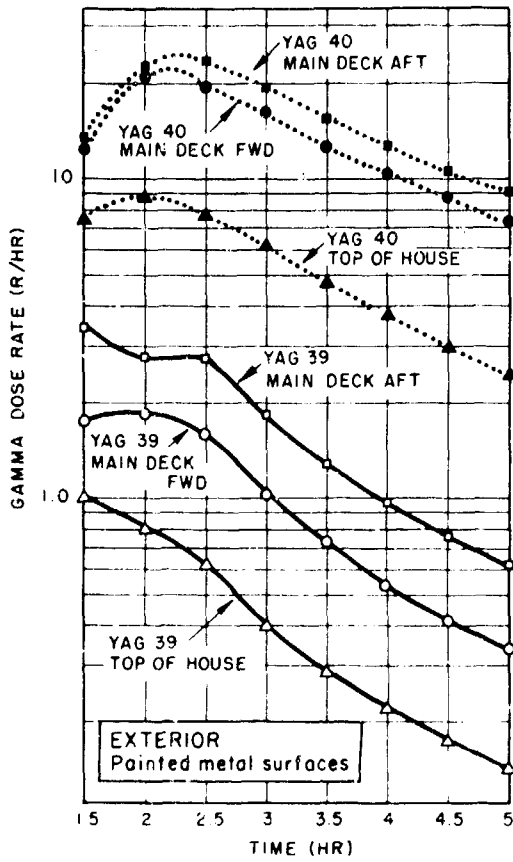

Figure 2.12 Gamma dose rate averages for some exterior areas vs time after Shot 4.

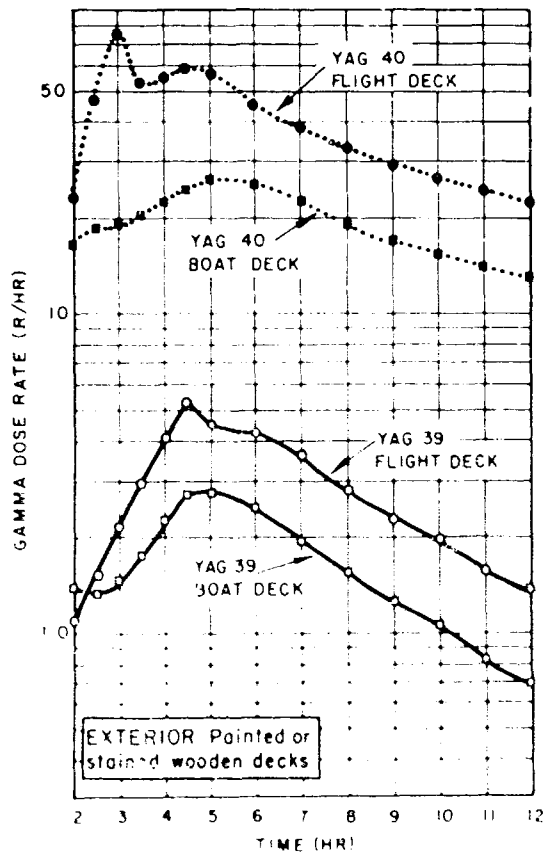
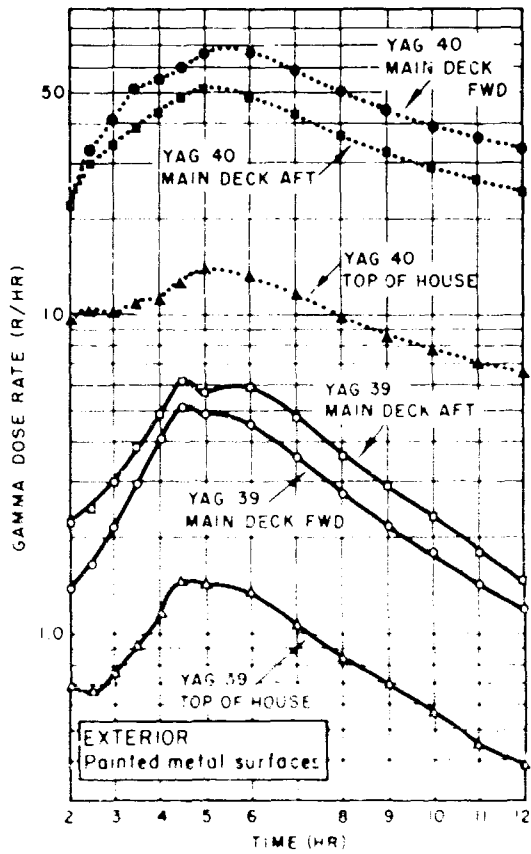

Figure 2.13 Gamma dose rate averages for some exterior areas vs time after Shot 5.

tions was 300 r, which indicates that dangerous radiation effects may be encountered in contaminating events of this type. The exterior locations were: the flight deck area, which simulated a portion of a windswept Essex Class CV flight deck; the boat deck area, which simulated wooden main decks adjacent to structures aboard large combatant ships; the forward main deck area, which simulated a complex of steel deck including open areas, gun tubs, and deck houses; the after main deck area (No. 4 hatch area), which simulated steel deck in the lees of superstructures; and the top of house area, which simulated unobstructed windswept steel decks. Detailed study of data from Station 64 in the recorder room indicated that the dome wash water did not affect the radiation data to a detectable degree. The detector stations on top of the house were partially shielded and had a geometry roughly half that of other stations on the decks; this fact precludes direct comparison of dose and dose-rate data with that of other exterior areas.

The adjusted dose and dose-rate averages for interior areas are shown in Figures 2.14 through 2.21. The data for individual stations are shown in Tables A.13 through A.19, Appendix A. The interior areas were: the stateroom area, which simulated compartments near or adjacent to weather surfaces; the second deck area, which simulated compartments near boiler air ducts above armored decks but fairly remote from weather surfaces; the bottom of No. 2 hold area, which simulated compartments remote from weather surfaces but without much intervening structure; the recorder room area, which simulated compartments below the waterline, adjacent to the shell, and well shielded from weather surfaces; the boiler firing aisle area, which simulated a fireroom lower level duty station between boilers; and the starboard boiler station, which measured the radiation contribution from the lower level front of the boiler located over the first plenum chamber from which both boilers drew air.

2.5.4 Washdown Effectiveness for Exterior Areas. The washdown effectiveness, defined as the percentage reduction in accumulated gamma dose at exterior locations, is presented in Figures 2.22 and 2.23. The values range between 87 to 94 percent at the end of the fallout period, considering both Shots 4 and 5. The values have only increased to a range between 89 to 95 percent as late as 2 hr after end of fallout from Shot 4. Figure 2.22 shows that there are only minor improvements in effectiveness values after the end of the fallout that occurred at 3 hr after Shot 4. Figure 2.23 shows that there are only minor improvements in effectiveness values later than 3 hr after Shot 5 and that these values are about the same as those for Shot 4, even though there was fallout as late as 12 hr after Shot 5. It would appear that, for this type of contaminating event, a major benefit of the washdown was the suppression of accumulated gamma dose during the fallout phase.

The washdown effectiveness defined as the percentage reduction in gamma dose rates at exterior locations is presented in Figures 2.24 and 2.25. The values range between 90 to 96 percent at the end of the fallout period, considering both Shots 4 and 5. The values have only increased to a range between 93 to 97 percent as late as 2 hr after end of fallout from Shot 4. The effectiveness based upon dose rates shows a greater dependence upon the rate of arrival of fallout than does the effectiveness based upon dose; however, the washdown does suppress the radiation fields to a large extent, even during the maximum fallout periods.

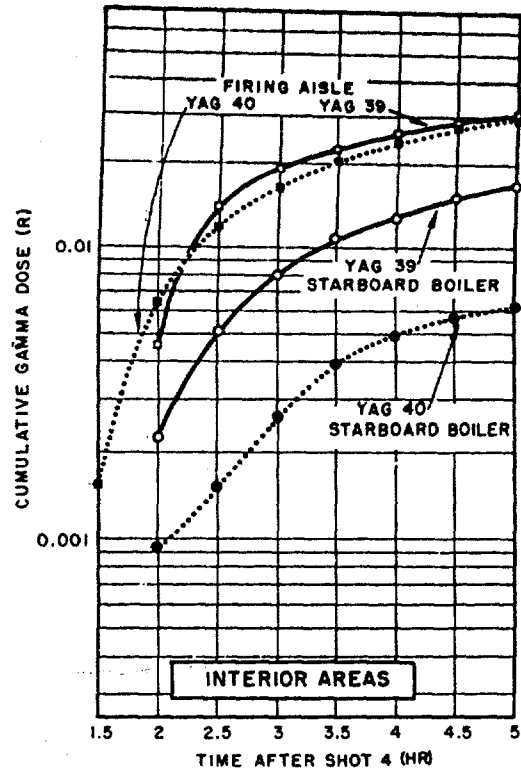
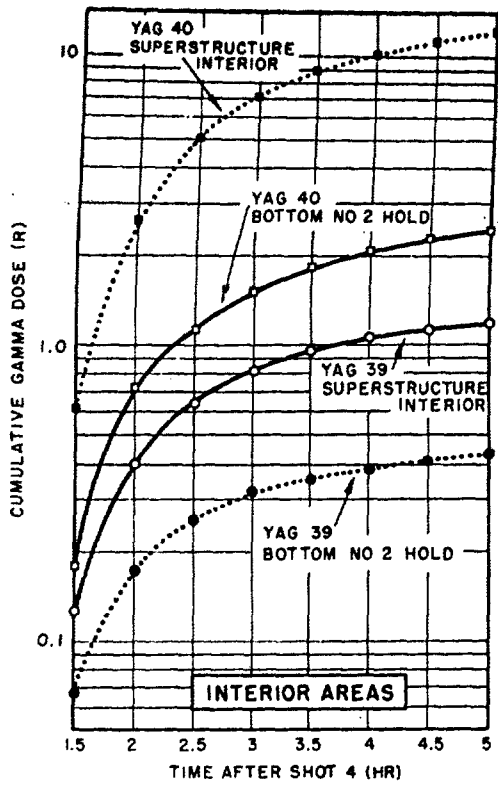

Figure 2.14 Cumulative gamma dose averages for some interior areas vs time after Shot 4.

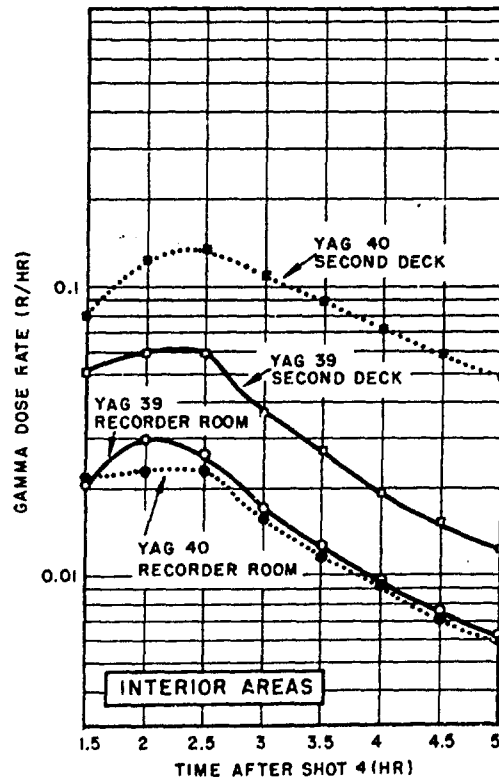
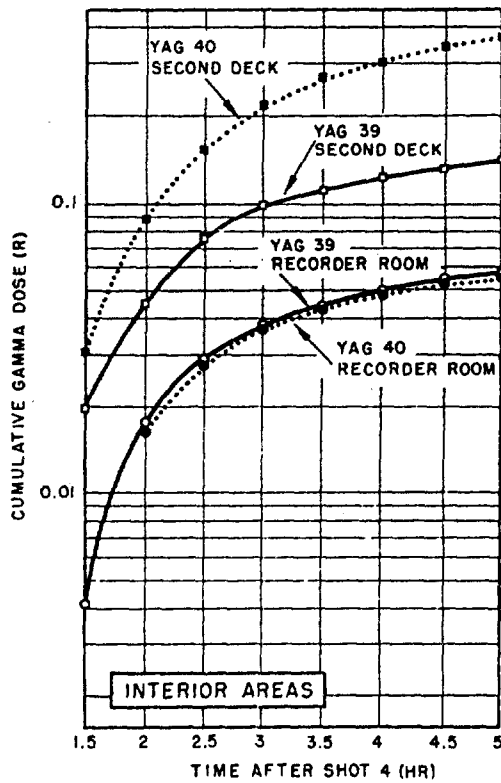

Figure 2.15 Cumulative gamma dose averages for some interior areas vs time after Shot 4.

Figure 2.16 Gamma dose rate averages for some interior areas vs time after Shot 4.

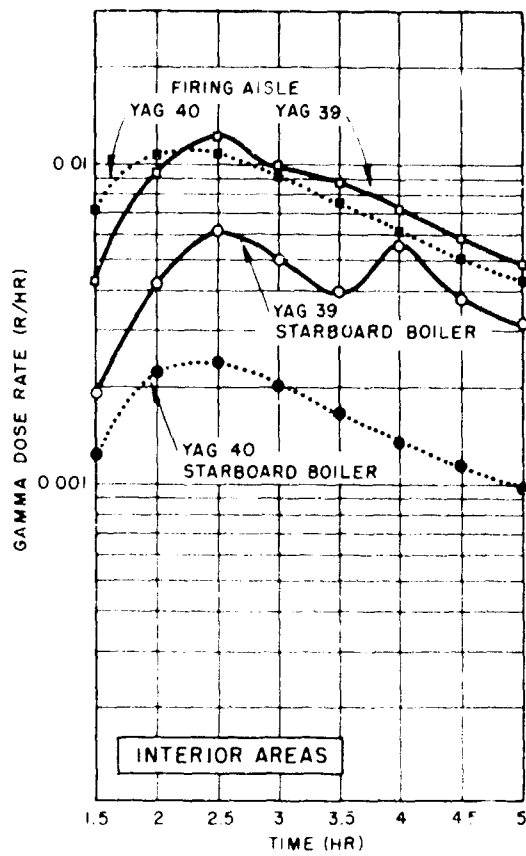
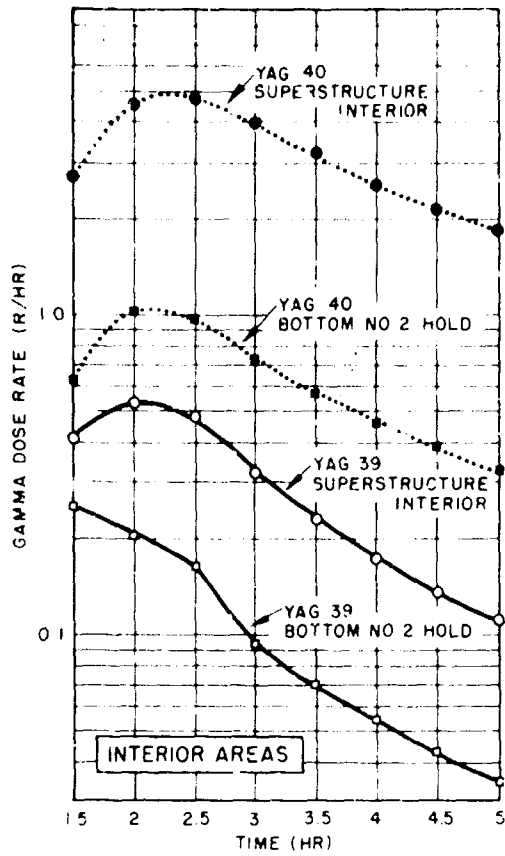

Figure 2.17 Gamma dose rate averages for some interior areas vs time - Shot 4.

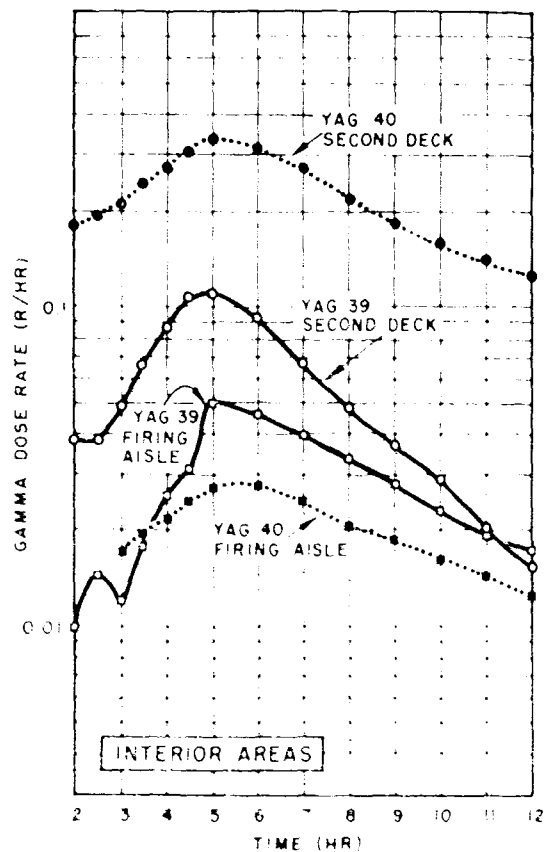
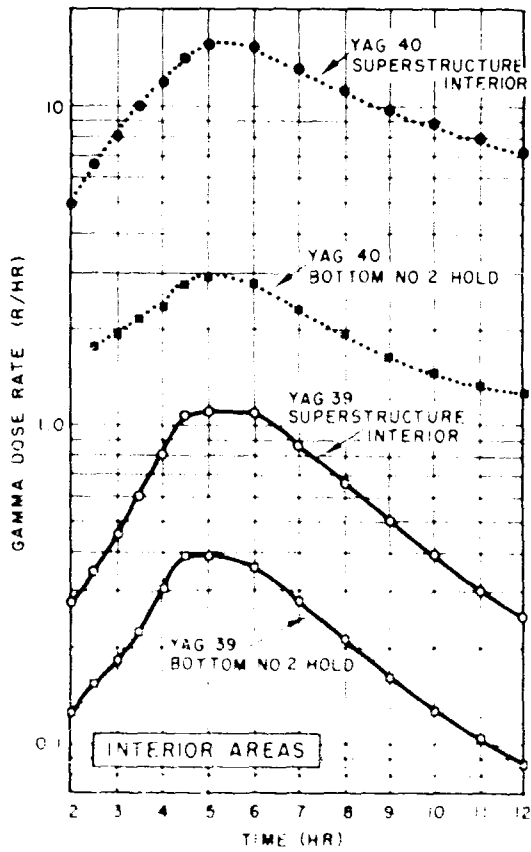

Figure 2.18 Gamma dose rate average for some interior areas vs time after Shot 5.

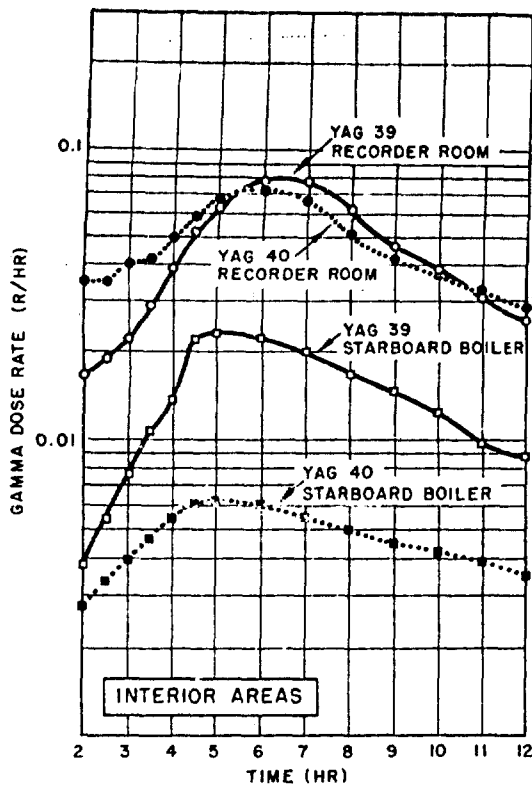

Figure 2.19 Gamma dose rate average for some interior areas vs time after Shot 5.

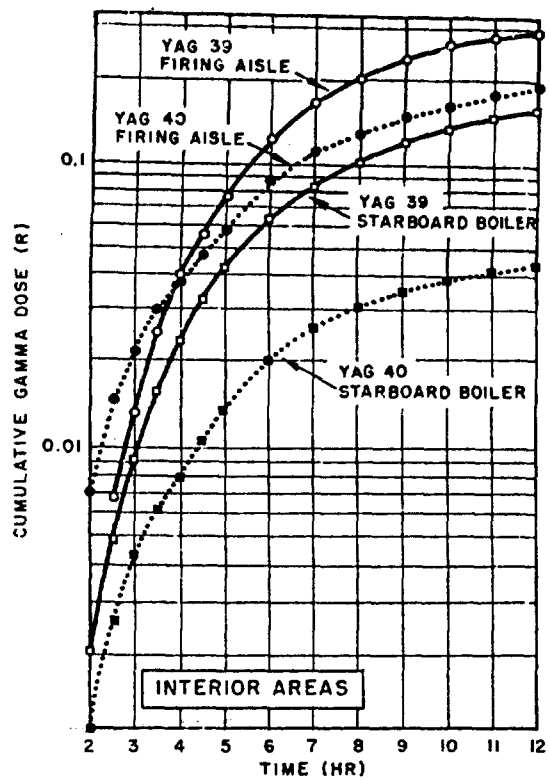

Figure 2.20 Cumulative gamma dose average for some interior areas vs time after Shot 5.

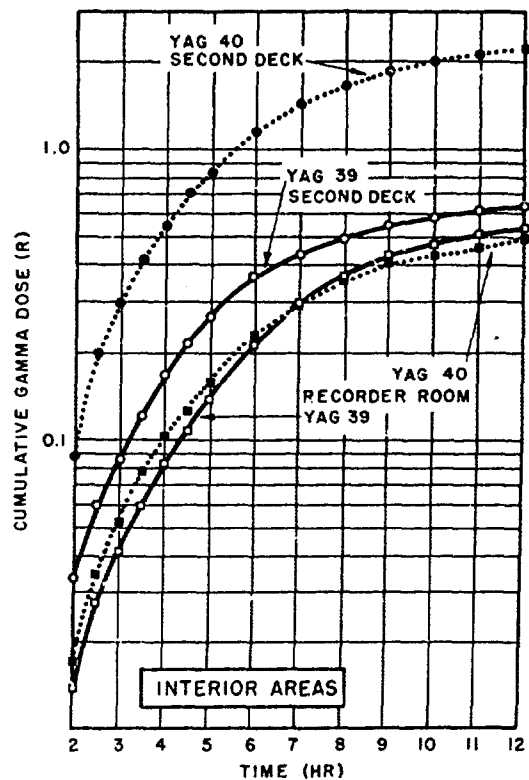
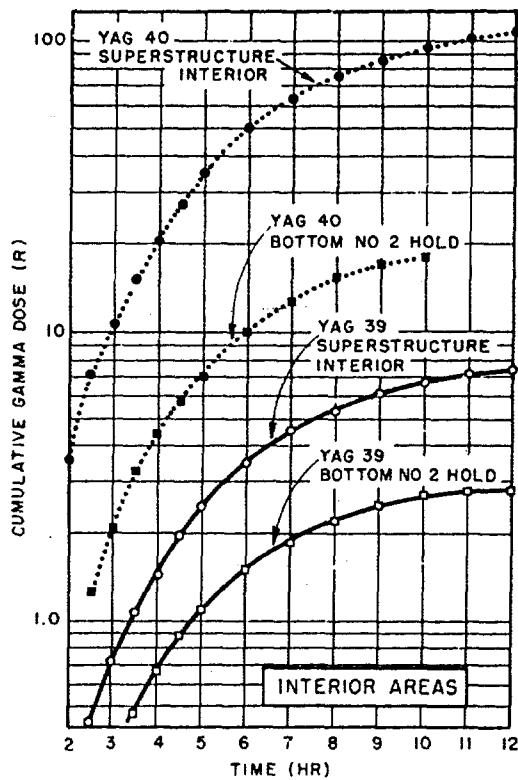

Figure 2.21 Cumulative gamma dose average for some interior areas vs time after Shot 5.

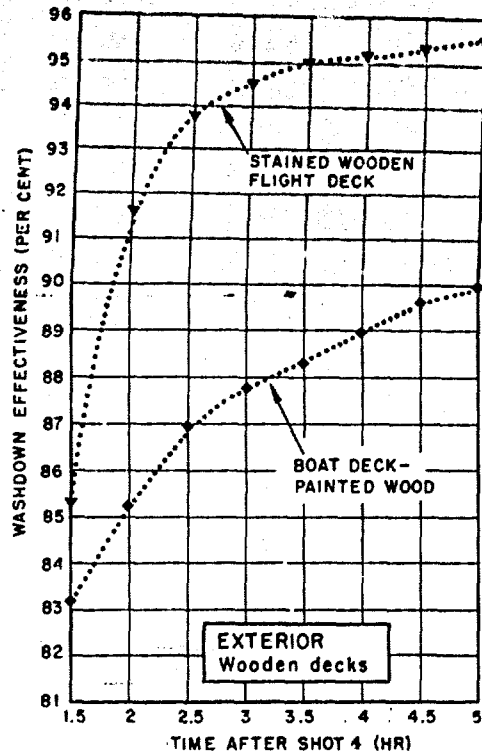
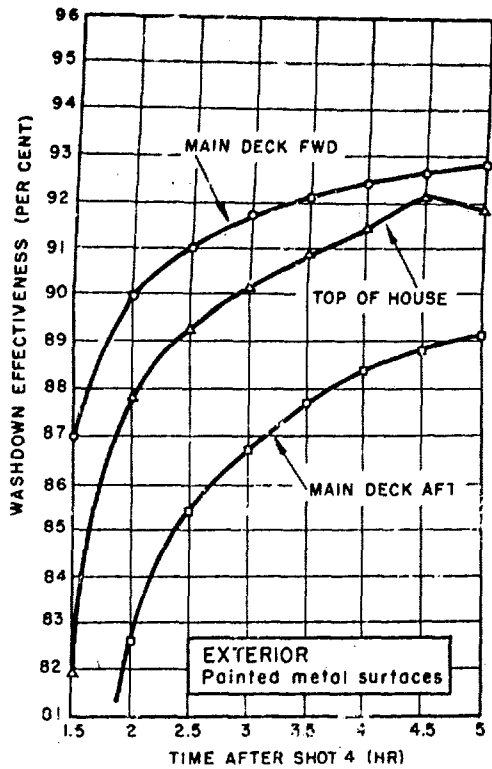

Figure 2.22 Washdown effectiveness achieved on some exterior areas vs time after Shot 4, based on cumulative gamma dose.

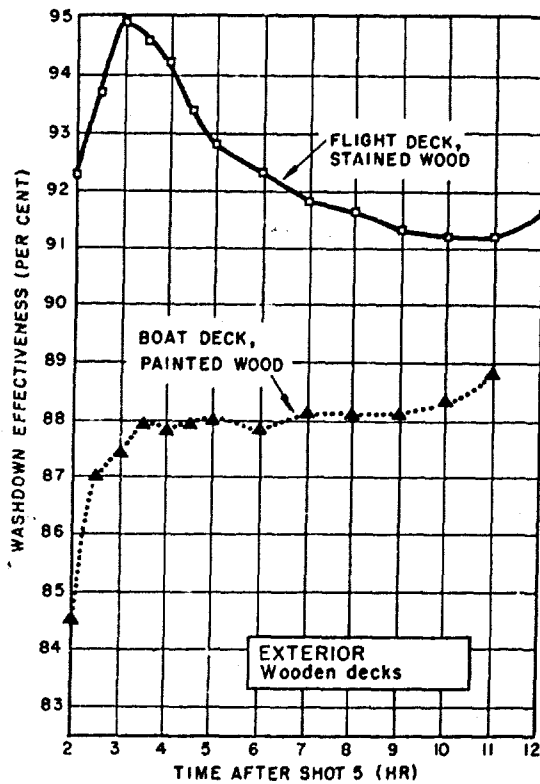
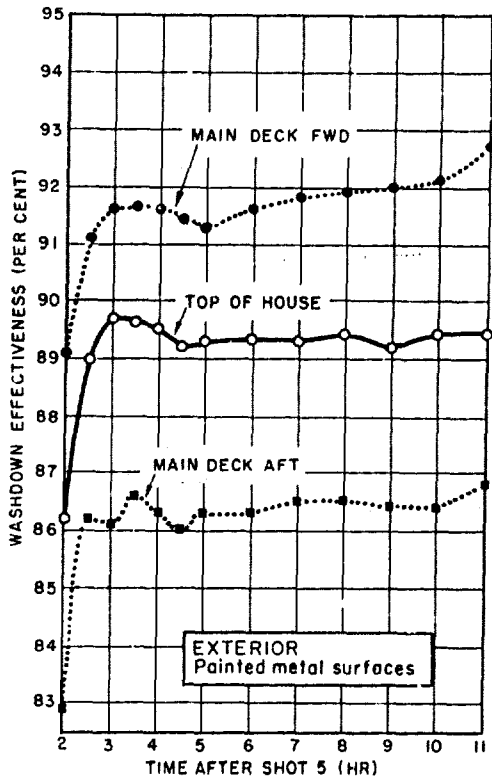

Figure 2.23 Washdown effectiveness achieved on some exterior areas vs time after Shot 5, based on cumulative gamma dose.



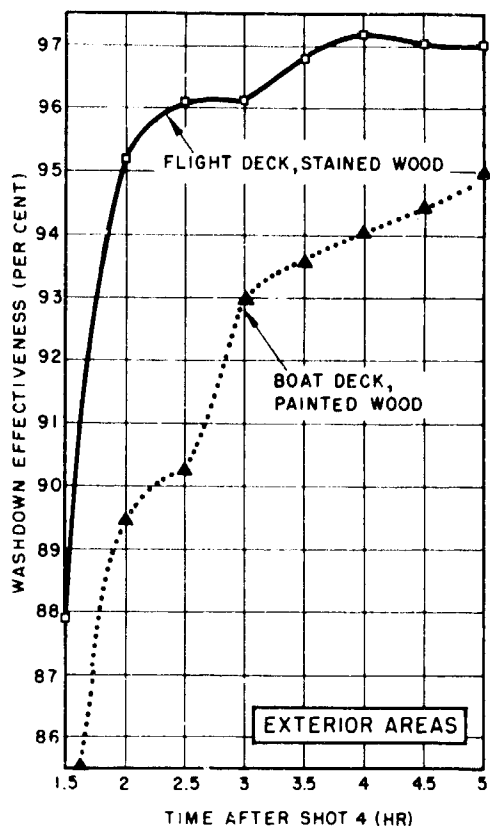
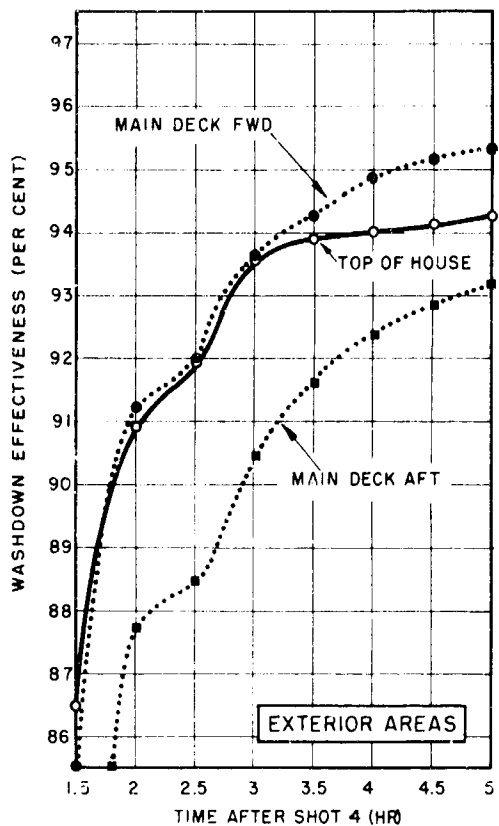

Figure 2.24 Washdown effectiveness achieved on some exterior areas vs time after Shot 4, based on dose rate.

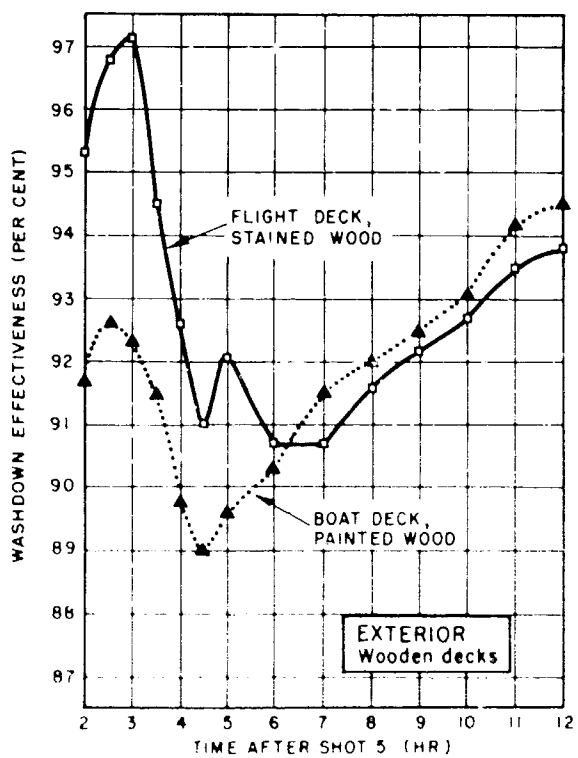
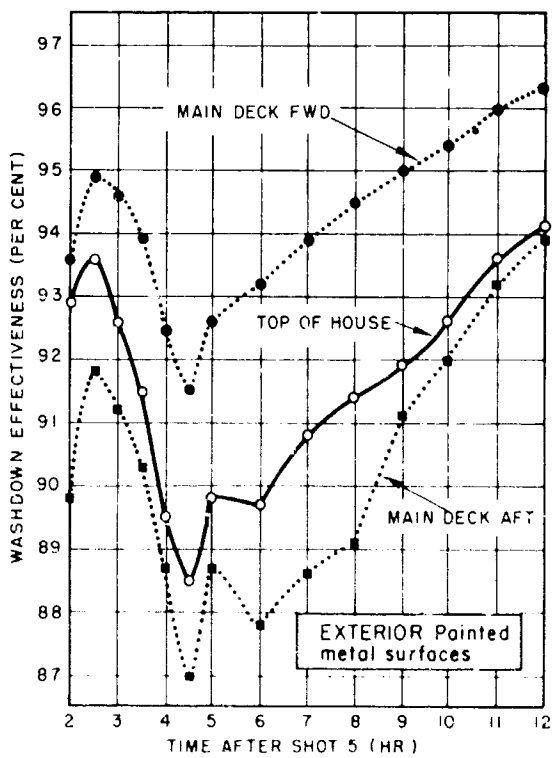

Figure 2.25 Washdown effectiveness achieved on some exterior areas vs time after Shot 5, based on gamma dose rate.

Figure 2.26 shows how the washdown effectiveness varies with the decay-corrected dose rates, which represent the amounts of contaminant on the surface and in the air envelope, using the flight deck area during Shot 5 as an example.

2.5.5 Washdown Effectiveness for Interior Areas. In the recorder room and fireroom stations, the term "washdown effectiveness" has no meaning. For these areas the YAG 39/YAG 40 ratios of dose and of dose rate are presented in Figures 2.27 through 2.30. These areas are so well shielded from the weather surfaces that they are almost unaffected by the removal of contaminants from the decks. The results of the radiation contributions from the starboard boiler (Station 59) were somewhat unexpected. These results would tend to indicate that the washdown caused an increase in radiation effects from the boiler system during these tests. The magnitudes of dose and dose rate contributed by this particular boiler system were almost negligible (see Figures 2.14, 2.17 and 2.19), but it must be pointed out that combatant ships draw very much more boiler air than these test ships.

The washdown effectiveness values for the other interior areas are presented in Figures 2.31 through 2.34. As might be expected, the more the areas are shielded from the weather surfaces the less is the influence of removal of contamination from deck areas. Note that the effectiveness values for the stateroom area are comparable to those of the weather deck areas.

2.5.6 Some Factors Influencing the Washdown Effectiveness. The washdown supply flow rates, the drainage flow rates from several areas, and the relative wind velocities are presented in Figures A.2 through A.5 in Appendix A.

Table 2.1 shows estimates of nominal flow rates of water over various exterior deck areas.

Table 2.1 Average Water Flow Over Exterior Deck Areas

Area	Surface	Average Water Flow gpm/sq ft	Obtained by
Flight Deck	Stained Wood	0.083	Drainage Measurement
Boat Deck	Painted Wood	0.09	Comparison with Flight Deck during Shot 1
Main Deck Fwd.	Painted Steel	0.06	Estimate
Top of House	Painted Steel	0.08	Drainage Measurement
Main Deck Aft (No. 4 Hatch Area)	Painted Steel	0.04	Estimate

The values for the flight deck and top of house areas were obtained from the measured drainage flow rates. The value for the boat deck was obtained by comparison with the flight-deck values during Shot 1, when measurements from both areas were available. The values for the main deck areas were based upon the number of nozzles in the areas and the average flow from each nozzle, using the flight-deck area as a means of comparing estimates derived by this technique with values determined by measurement.

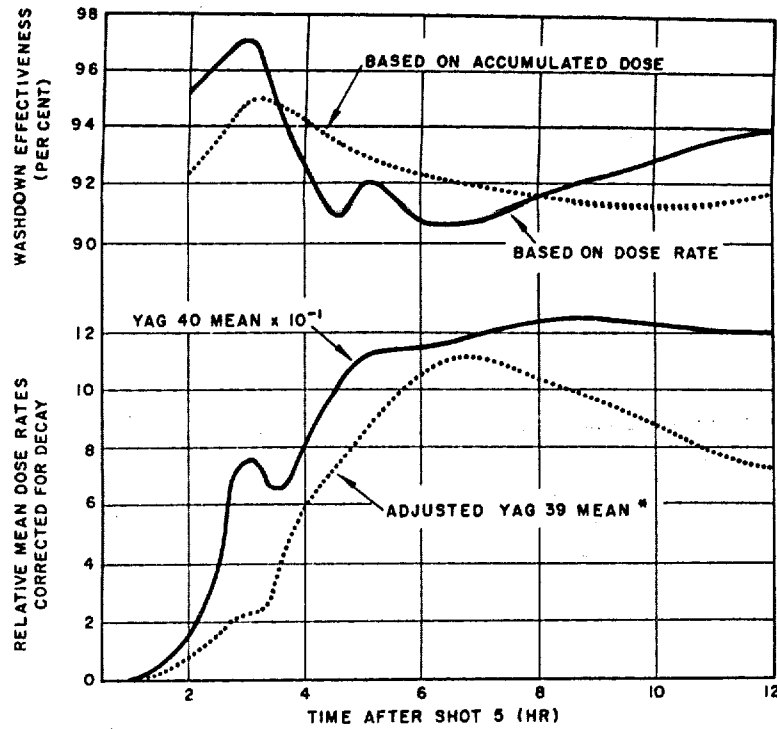

Figure 2.26 Example of relationship between washdown effectiveness and decay corrected dose rates vs time after Shot 5. Data from flight deck.

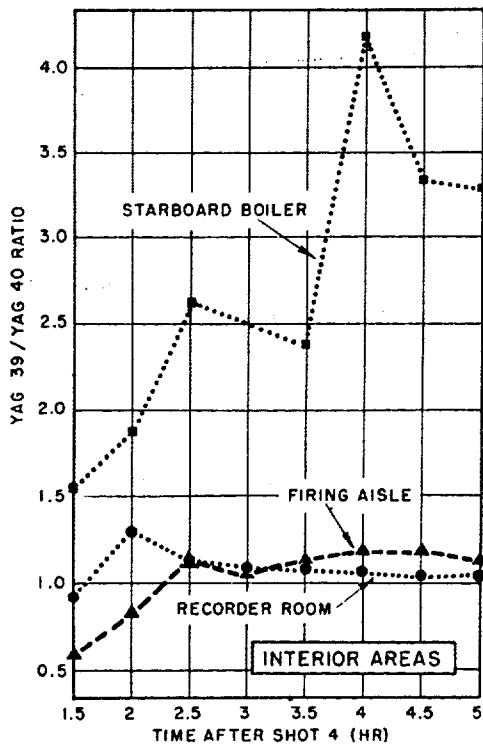

Figure 2.27 YAG 39/YAG 40 ratio of gamma dose rates for some interior areas vs time after Shot 4.

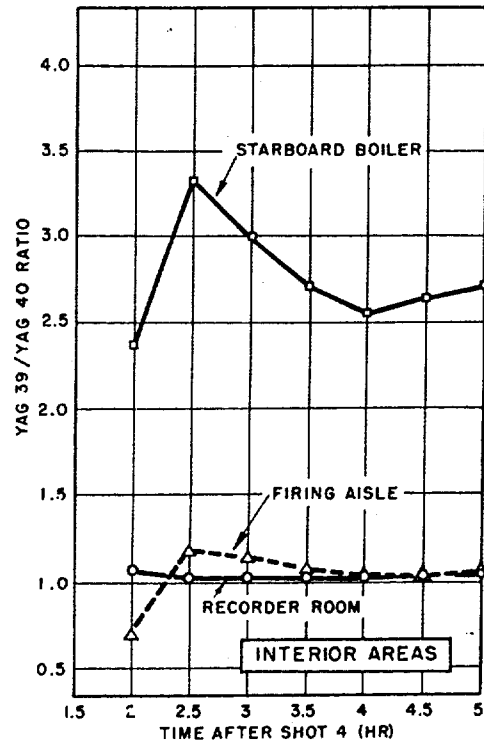

Figure 2.28 YAG 39/YAG 40 ratio of cumulative gamma dose for some interior areas vs time after Shot 4.

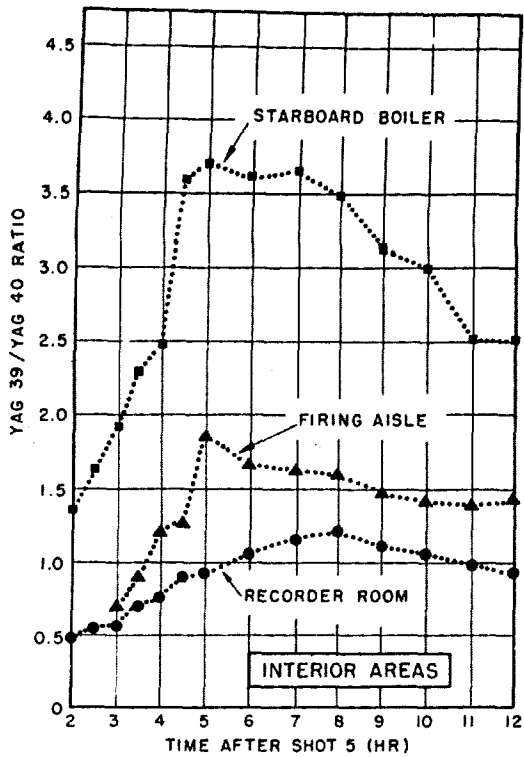

Figure 2.29 YAG 39/YAG 40 ratio of gamma dose rate for some interior areas vs time after Shot 5.

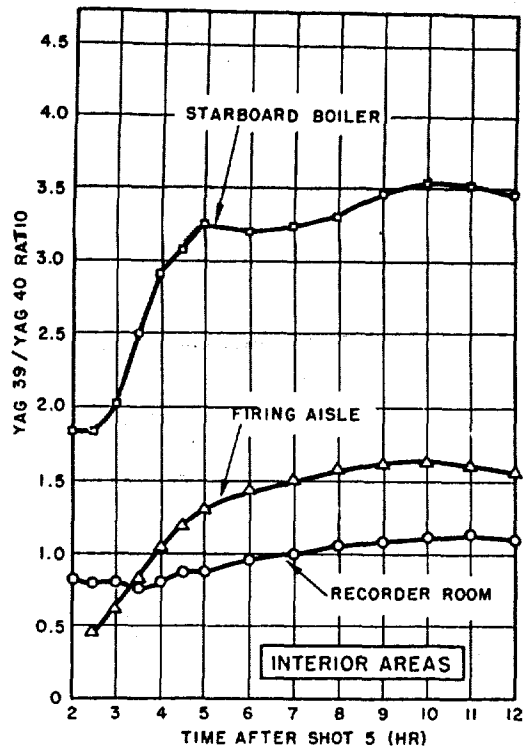

Figure 2.30 YAG 39/YAG 40 ratio of cumulative gamma dose for some interior areas vs time after Shot 5.

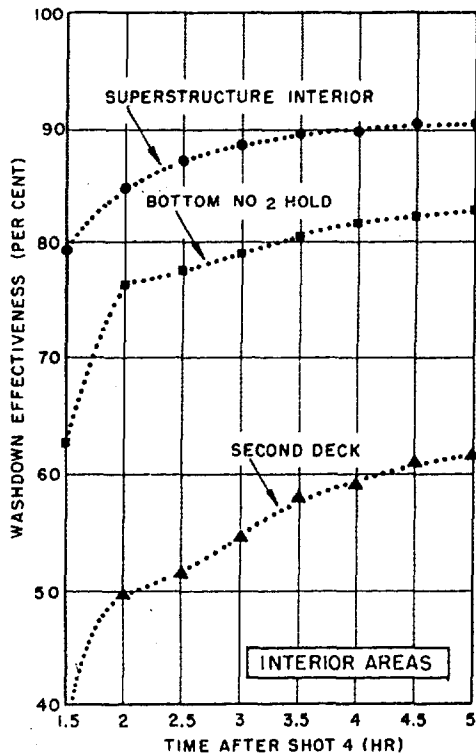

Figure 2.31 Washdown effectiveness for some interior areas vs time after Shot 4, based on cumulative gamma dose.

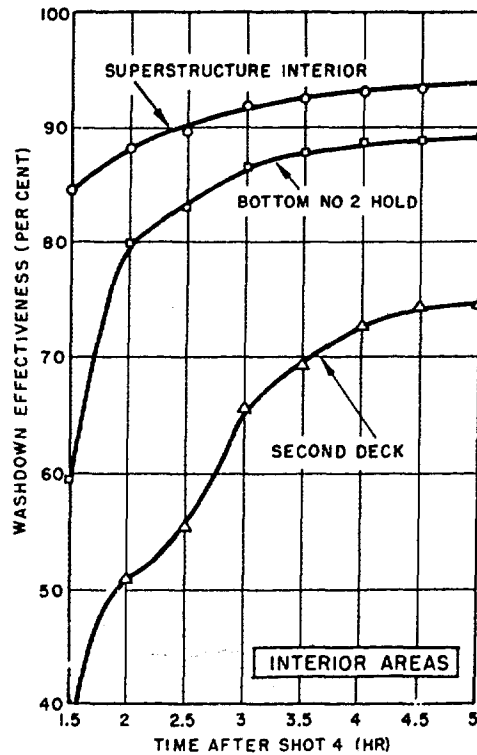

Figure 2.32 Washdown effectiveness for interior areas vs time after Shot 4, based on gamma dose rate.

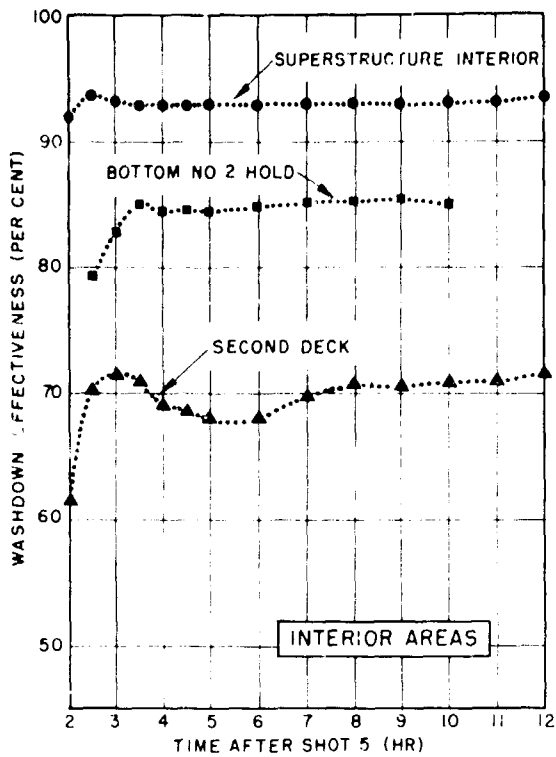
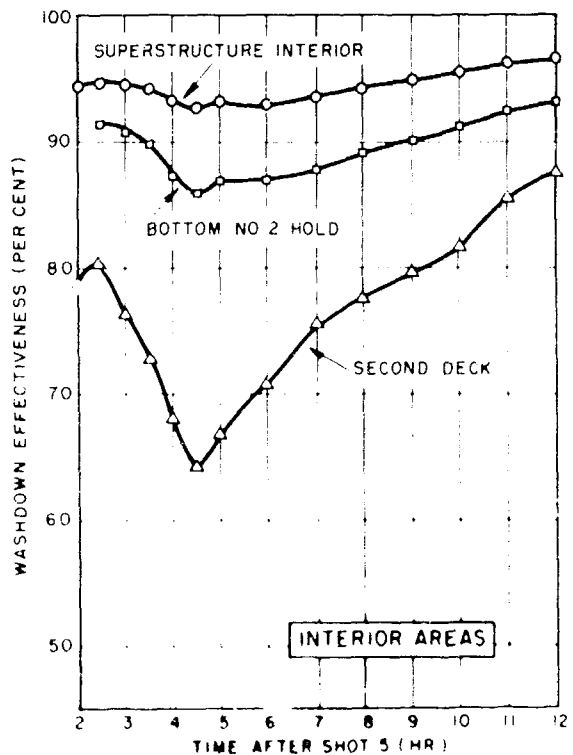

Figure 2.33 Washdown effectiveness for some interior areas vs time after Shot 5, based on gamma dose rate.

Figure 2.34 Washdown effectiveness for some interior areas vs time after Shot 5, based on gamma dose rate.



The strainer in the boat-deck drainage system clogged up during both Shots 4 and 5; therefore, the boat-deck area had to rely upon the ship's roll for drainage. This drainage was seriously impeded by the built-up trough which had been installed to trap all water on the boat deck for measurement.

Comparison of effectiveness values for the boat-deck and flight-deck areas indicate that, given similar water flow rates, a combination of impeded drainage and sheltered location may adversely affect the washdown effectiveness.

Comparison of the three painted steel areas (i.e., main deck forward, top of house, main deck aft), shows that the washdown effectiveness values are in the same relative order as are the estimated water flow rates. This may or may not be coincidence, because there were some differences in the extent to which these areas were sheltered from the wind by nearby structures. British test reports (Reference 4) claim virtual independence of water curtain effectiveness with respect to flow rates.

Figure 2.35 shows how the washdown appears when the relative wind is abeam. To observe how this would affect the performance of the washdown countermeasure, see Figure 2.36. The YAG 39/YAG 40 ratio of dose rates represents the fractional gamma field encountered when this washdown system is used. A comparison of these fractional fields is made between starboard and port stations on several exterior areas of the ships for Shot 4. With the exception of the flight deck area, results which seem somewhat anomalous, the trend indicates that there is loss of washdown effectiveness on that side of the ship which faces the wind and which has poorer water coverage. This points out that zigzagging, circling, or other maneuvering which helps the distribution of water over the weather surfaces, is needed for optimum washdown effectiveness. This confirms similar conclusions arrived at during prior testing using simulants (References 1, 2). During these tests the ships did not follow sinusoidal courses as originally planned; the only maneuvering done was that required for the ships to maintain station on courses estimated to intercept significant fallout areas.

## 2.6 CONCLUSIONS

The objectives of obtaining information to allow valid determination of washdown effectiveness have been met for the type(s) of contaminating events encountered at Operation Castle. It must be emphasized that the following conclusions are based solely upon the test results obtained from Shots 4 and 5 and may not apply to other types of contaminating events.

The greatest merit of the washdown countermeasure was found to be the great reduction in gamma radiation fields and dosage during the fallout of radioactive contaminants. The reduction in accumulated gamma dose at exposed locations was found to range between 87 to 94 percent at the end of the fallout period, whereas subsequent washing for 2 hr increased this reduction only to 89 to 95 percent. The reduction in gamma dose rates at exposed locations was found to range between 90 to 96 percent at the end of the fallout period; whereas subsequent washing for 2 hr increased this reduction only to 93 to 97 percent.

At interior locations, the contamination in the water envelope and

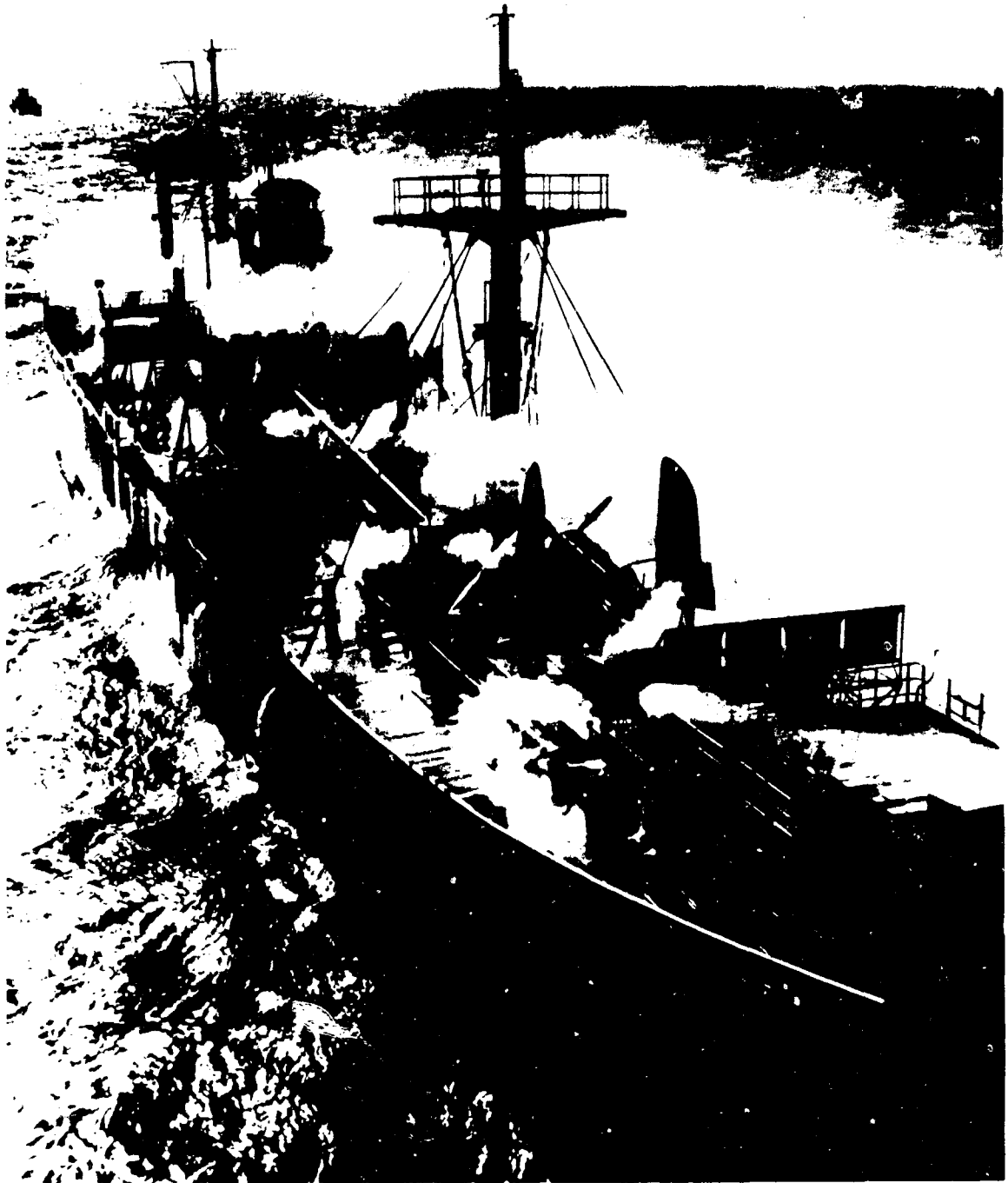

Figure 2.35 Washdown with wind abeam.

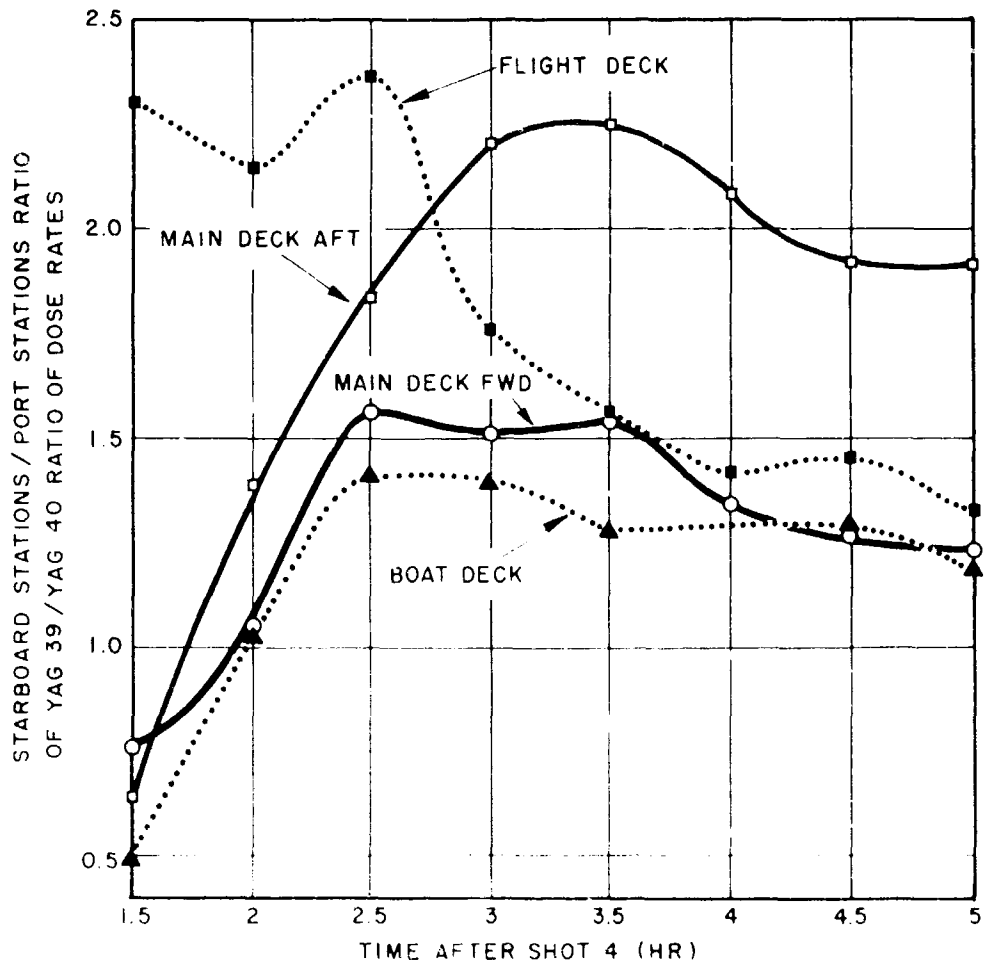
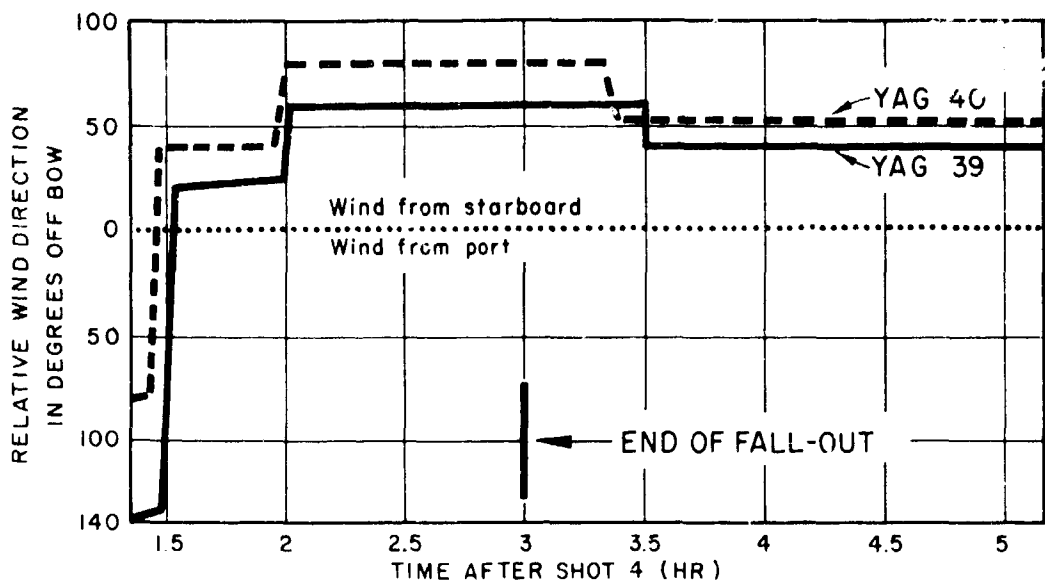

Figure 2.36 Relationship between relative wind direction and the starboard/port comparison of YAG 39/YAG 40 ratios of dose rates vs time after Shot 4.



in the salt-water-circulating and boiler-air systems were considered to be responsible for the observed decrease in washdown effectiveness with increase in distance and shielding from weather surface areas. There is a probability that the washdown was responsible for an increase in the radiation contributed by the boiler; the increase was high, but the magnitude of the radiation intensity was negligible for this particular boiler system.

The transit dose was estimated to be of minor significance on a ship not protected by washdown. On a washdown-protected ship, it was estimated that as much as half of the total dose accumulated at the end of the fallout period may be due to the transit dose.

The washdown effectiveness was found to be adversely influenced by poor water drainage from weather surfaces, relatively low water supply flow rates, and lack of maneuvering when the wind was abeam.

Lack of time may have prevented the full utilization of all information or correlations derivable from the recorded data and postshot radiation surveys. All data will be processed and filed for future screening.

## 2.7 RECOMMENDATIONS

The washdown countermeasure has been shown to have a high effectiveness against fallout of the types encountered during these tests, but it should also be field tested for effectiveness against base surges or other types of contaminating events which may differ from fallout phenomena.

Some nozzles should be located near the sides of the ship to minimize wind effects, any obstructions to drainage should be removed, and ships should maneuver to help distribute the wash water in order to obtain optimum washdown effectiveness.

For future tests, it may be advantageous to use one fast ship, with washdown protecting half of it and with test crews well shielded, instead of two slow ships. This should result in simpler operations, greater ability to intercept areas of contamination, and insure more-nearly equal contaminating events for the protected and unprotected test areas.

The possibility that washdown may cause a significant increase in radiation fields from contaminants in high-capacity boiler systems merits further investigation.

## Chapter 3

# SHIP SHIELDING

C. F. Ksanda

A. Moskin

The shielding effectiveness of ships' structures for attenuating gamma radiations in interior compartments during and after a contaminating event is discussed. The overall shielding factor is defined as the ratio of the dose rate within a compartment to that measured above the weather deck. Three sources of radiation are considered: deposited, airborne, and waterborne radioactive materials.

Radiation was measured as a function of time in compartments below decks and in the superstructure. To obtain data applicable to compartments below armored decks of naval vessels, radiation measurements were made in a lower hold underneath a 12-in.-thick concrete deck and also between the main and second decks underneath 2-in. and 4-in. steel plates. Other measurements to determine the gross absorption characteristics as a function of time were made on deck inside steel pipes that had wall thicknesses ranging from 1/8 in. to 4 in.

It was found that the apparent absorption coefficient increases regularly with time and that the shielding factor for below-deck compartments decreases with time and distance from the weather decks. Furthermore, of the two ships used for the tests, the shielding factor was greater for the ship that was equipped with the washdown system. Although superstructure data were not so consistent, they showed the same general trend. Deposited activity-shielding factors for well-shielded locations show the greatest discrepancy between calculated and observed data.

The results obtained apply only to the conditions of these tests and cannot be extrapolated directly to conditions where the relative magnitude of the three sources of radiation are greatly different.

### 3.1 OBJECTIVE

The objective of this study was to obtain data on the shielding effectiveness of ships' structures in attenuating gamma radiations in interior compartments during and after a contaminating event. The study was intended to evaluate the shielding effectiveness of the ships' structures with respect to both radioactive material deposited on the weather surfaces and airborne radioactive material during the fallout event. The information obtained was intended primarily for comparison with theoretical calculations to determine with what confidence such calculations could be applied to various classes of naval vessels, with or without washdown systems.

To attain the objective, several specific tasks were undertaken.

#### 3.1.1 Measurements in Compartments Below Deck Gamma-radiation

measurements were made in several compartments below the upper deck (main deck), removed from the boiler and ventilation air ducts. To acquire data more nearly applicable to compartments below armored decks in naval vessels, dose rates and dosages were measured not only in normal compartments but also beneath the 12-in. concrete slab of the instrument recording room and beneath two steel plates, 2 in. and 4 in. thick, mounted between the upper deck and the second deck.

3.1.2 Measurements in Compartments of the Superstructure. Measurements were made in various compartments of the superstructure at each deck level.

3.1.3 Measurements Inside Eight Steel Pipes. To obtain a gross measurement of the absorption characteristics of the radiation as a function of time, continuous dose-rate measurements were also made inside a series of eight steel pipes, ranging from 1/8 in. to 4 in. in wall thickness, mounted on the upper decks of the two ships.

### 3.2 BACKGROUND AND THEORY

Methods have been devised for computing the gamma radiation intensity at any point above or below rectangular slabs of attenuating materials, one surface of which is uniformly contaminated by radioactivity (Reference 5). These methods have been used at NRDL for computing the shielding factors<sup>1</sup> in below-deck compartments of naval vessels, considering the weather decks to be uniformly contaminated. These calculations, necessarily for highly idealized situations, were intended to provide an estimate of the shielding afforded from radioactivity deposited on weather surfaces.

Similar calculations have been made for ships surrounded by a cloud of radioactivity. These results were intended to provide an estimate of the shielding afforded from airborne activity during the contaminating event.

A third source of radiation, indicated in Chapter 2, is from radioactive material in the water surrounding the ship. Because of the different geometrical configuration of the radioactive material on weather surfaces, in the air during the contaminating event, and in the water during such time as the ship is in a contaminated region, the shielding factors at any given point will generally be different for each of these three sources. The overall attenuation at any location must be evaluated from each of the three shielding factors and the relative contribution to the total radiation level of each of the three sources. This subject is discussed in more detail in Appendix B.

The ultimate purpose of such evaluations is to provide a means for forecasting the relative safety of various locations on naval vessels. Such knowledge might provide a basis for altering the disposition of personnel in anticipation of atomic attack, or for making rapid estimates---

<sup>1</sup> The shielding factor is here defined as the ratio of the dose rate at the point of interest to the dose rate at a point 3 ft above the weather deck.

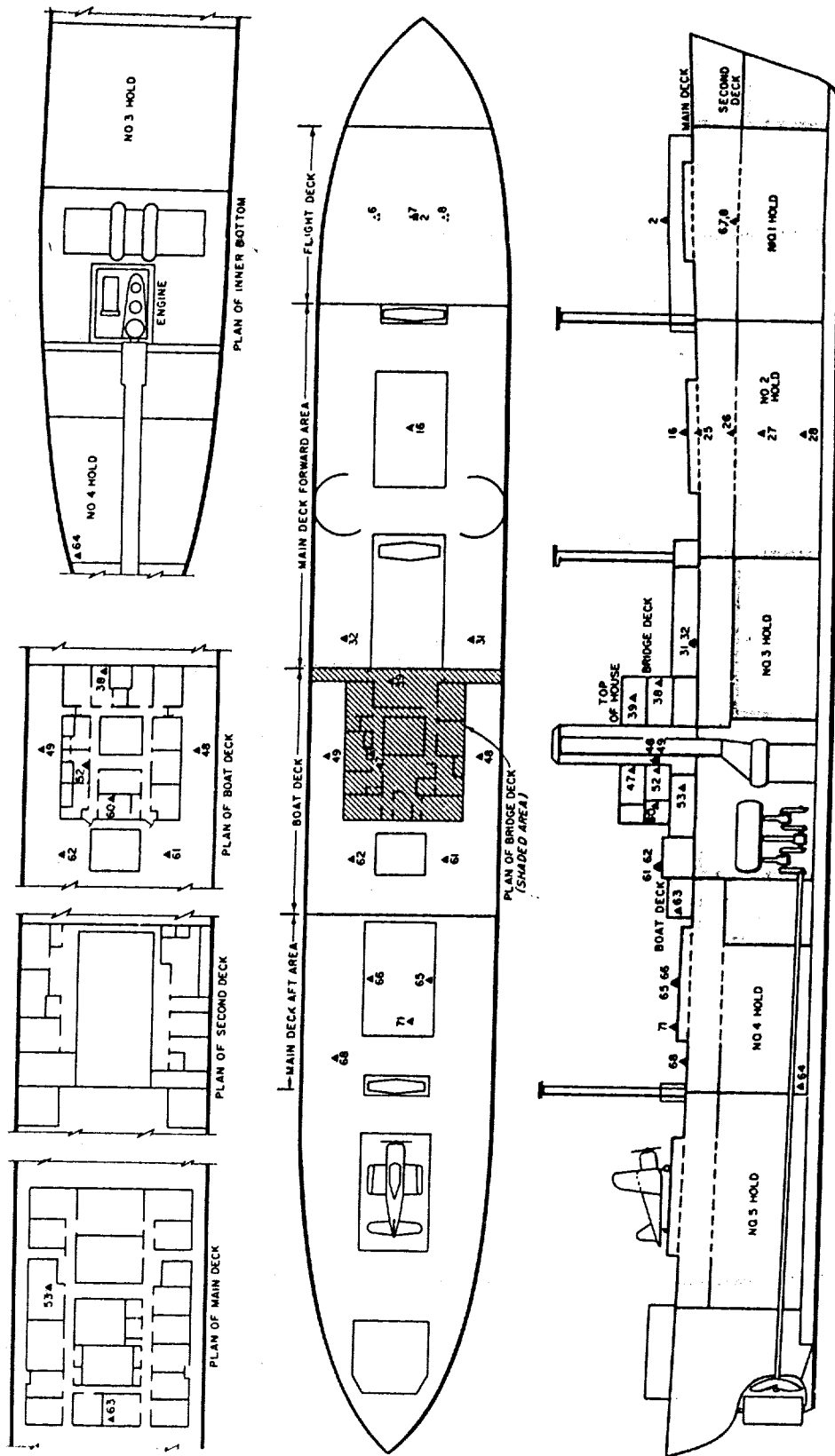

Figure 3.1.1 Location of instruments used in shielding studies.

on the basis of a few topside measurements---of the extent of radiation casualties following such an attack.

Previous tests have furnished some shielding information, but the data were either fragmentary, of low reliability, or difficult to interpret (notably in the case of Operation Crossroads) or not directly applicable to the case of fallout of bomb debris, as in experiments using single radioactive isotopes as radiation sources.

Project 6.4 offered the opportunity for studying shielding effectiveness of ships' structures for actual bomb debris fallout, in addition to supplying data directly applicable for interpreting the effectiveness of the washdown countermeasure in interior compartments. The shielding study was designed primarily to determine the shielding factors, as functions of time, for material deposited on weather surfaces, since this was considered to be the major source of radiation. It was also hoped to make some estimate of shielding from airborne activity during the fallout event. Subsequent analysis has indicated that, for these tests, shielding from radioactive material in the sea water must also be considered.

The steel pipe absorption studies were based on the premise that most of the radiation passing through the pipes was incident almost normally on the outer walls. Because of this simple geometry, it was considered that the complex radiation energy spectrum at any time could be interpreted in terms of a relatively simple absorption curve. The detectors inside the pipes measured the radiation from all directions. The absorption data therefore include the build-up in intensity from radiations reaching the detector after being scattered within the pipe walls, as well as the directly transmitted radiation. These absorption data are therefore directly applicable as basic information for computing shielding factors in interior compartments.

Dose-rate histories were obtained to determine the influence of the changing radiation energy spectrum with time, and similar measurements were made on both ships to determine whether contaminant redistribution or selective removal of nuclides by the washdown appreciably affected the shielding effectiveness.

### 3.3 INSTRUMENTATION

Dose-rate data were obtained in selected interior compartments where no ingress of radioactive contamination was expected at identical locations in both ships. Dose-rate histories were obtained for estimating shielding effectiveness as a function of time. Details of the gamma radiation detectors and recording system are given in Chapter 8. The locations of the particular instruments of interest in this chapter are shown in Figure 3.1. Approximate distances and deck plating thicknesses are also shown. Data taken at other stations for other studies may also be useful, but time limitations have precluded their use in this report.

Interior surveys were made to determine the variation in dose rate within compartments and, also, to determine the correlation between shielding effectiveness determined from the recorded dose time histories and from readings taken with ordinary survey meters. Details of the surveys are given in Chapter 9.

The location and dimensions of the steel plates are shown in Figure 3.2. Similar data for the steel pipes are given in Figure 3.3.

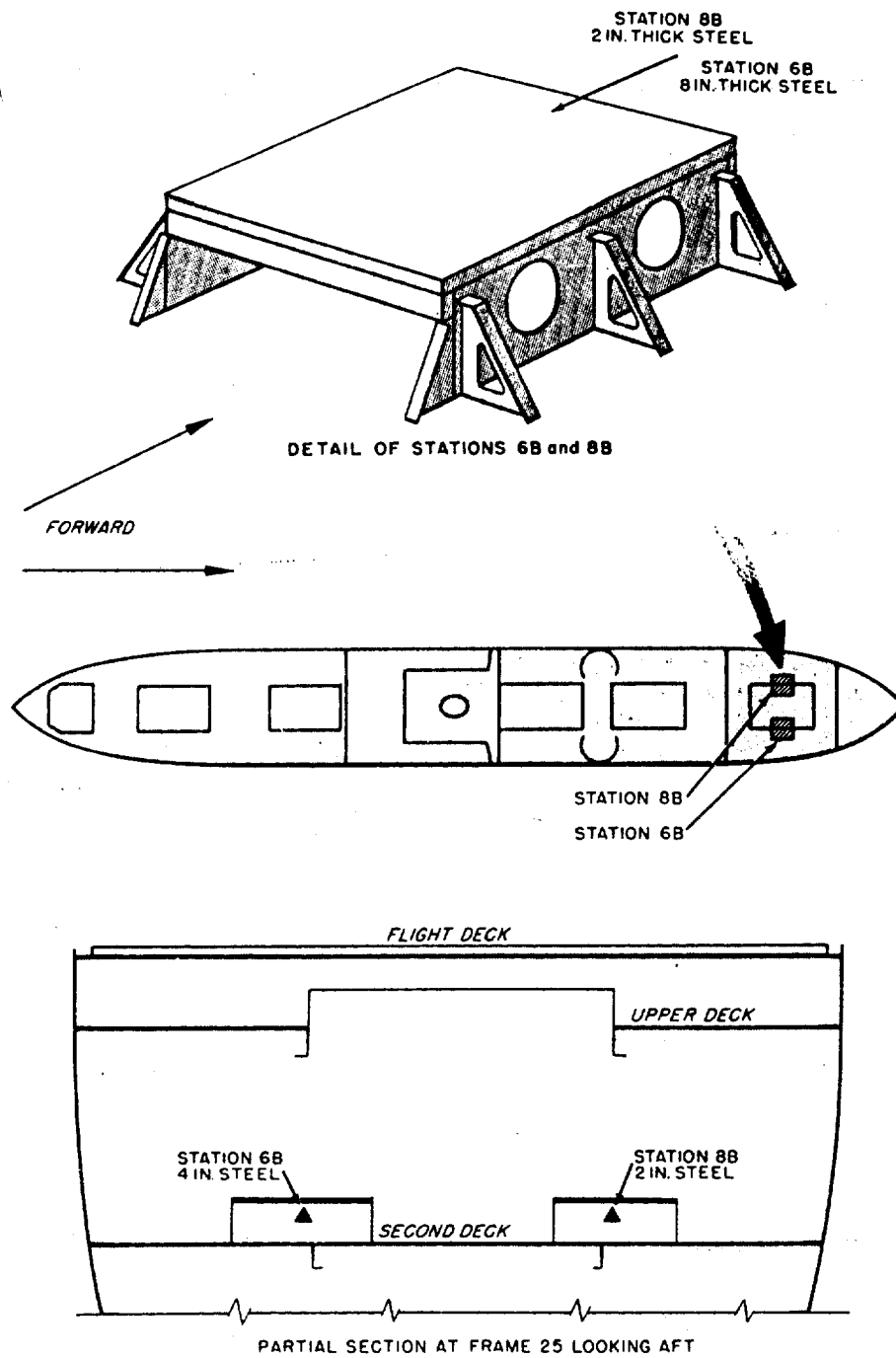
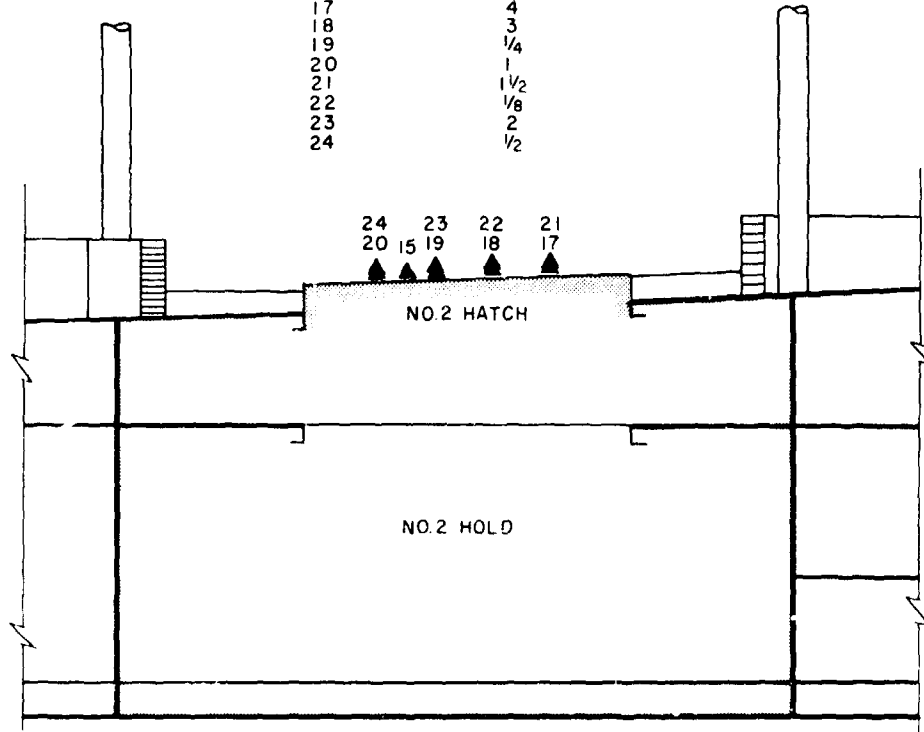

Figure 3.2 Location and dimensions of the steel plate for shielding studies.

STEEL THICKNESS OF BOTTOM, CYLINDER AND COVER

STATION NO.	THICKNESS (IN.)
17	4
18	3
19	1/4
20	1
21	1 1/2
22	1/8
23	2
24	1/2



INBOARD PROFILE OF NO. 2 HOLD SHOWING STATIONS

FORWARD

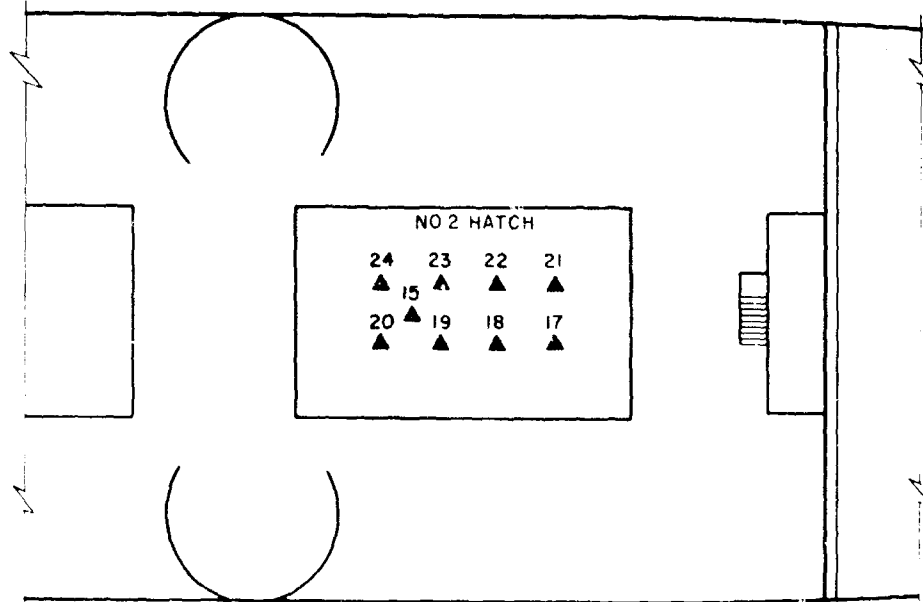

PLAN VIEW OF UPPER DECK WITH STATIONS ON NO. 2 HATCH

Figure 3.3 Location and dimensions of the steel pipes for the shielding studies.

### 3.4 RESULTS AND DISCUSSION

Adequate data were obtained from Shots 2, 4, and 5 for both ships. Because of the low radiation levels on YAG 39 for Shot 2, however, these data are considered less reliable than the remainder.

Results of the analysis have been confined principally to the determination of overall shielding factors, as a function of time, at the locations shown in Figure 3.1, and in analysis of the steel pipe data to determine the absorption characteristics of the radiations as a function of time. The overall shielding factor,  $F$ , is defined as the ratio of the dose rate within a compartment to that measured above the weather deck. As indicated in Section 3.2, the overall shielding factor applies only for the specific conditions of these tests and cannot be extrapolated directly to conditions where the relative magnitude of radiation levels from deposited activity, airborne activity, and waterborne activity is not the same as in these tests.

The results of Section 3.4.4, however, indicate that it is possible from the YAG 40 data to estimate the shielding factors for deposited activity; these are directly applicable to other conditions. Further analysis may make possible a quantitative evaluation of the radiation shielding from airborne and from waterborne activity. Meanwhile, certain qualitative conclusions can be made regarding the relative contribution of these sources compared to that from activity deposited on weather surfaces.

A predominant feature of all the data from below-deck spaces (mentioned in connection with washdown effectiveness in Chapter 2) is the smaller apparent shielding effectiveness on YAG 39 as compared to YAG 40. This observation may be attributed to the fact that the washdown system on YAG 39 suppresses the relative contribution of activity deposited on the decks and, hence, increases the relative importance of other radiation sources unaffected by the washdown. It is shown in Appendix B that, if the contribution from airborne and waterborne activity is small compared to that from weather surfaces, the ratio of shielding factors for the two ships should be nearly equal to 1. However, if the contribution from weather surfaces is small compared to that from airborne or waterborne sources, then  $F_{39}/F_{40}$  can approach a value equal to the ratio of the unshielded deck reading on YAG 40 to that on YAG 39. From Chapter 2, this ratio can be of the order of 10 or 20. Therefore, in locations well shielded from weather surfaces, it is possible for the overall shielding factor on YAG 39 to be an order of magnitude greater than on YAG 40.

3.4.1 Below-Deck Studies. The principal study of shielding at locations below the weather deck was made in hold No. 2, where four detectors were placed in a vertical line to measure the effect of increasing distance from the weather deck and of increasing thickness of steel. Stations 25 and 26 were between the upper deck (main deck) and the second deck, and Stations 27 and 28 were below the second deck. Ratios of dose rates from these detectors to rates from Station 16, directly above on the weather deck, are plotted against time in Figures 3.4 through 3.9.

A similar study was made between the upper deck (main deck) and second deck in No. 1 hold. Here the simulated flight deck was located above the hatch and the hold was waterloaded below the second deck level.



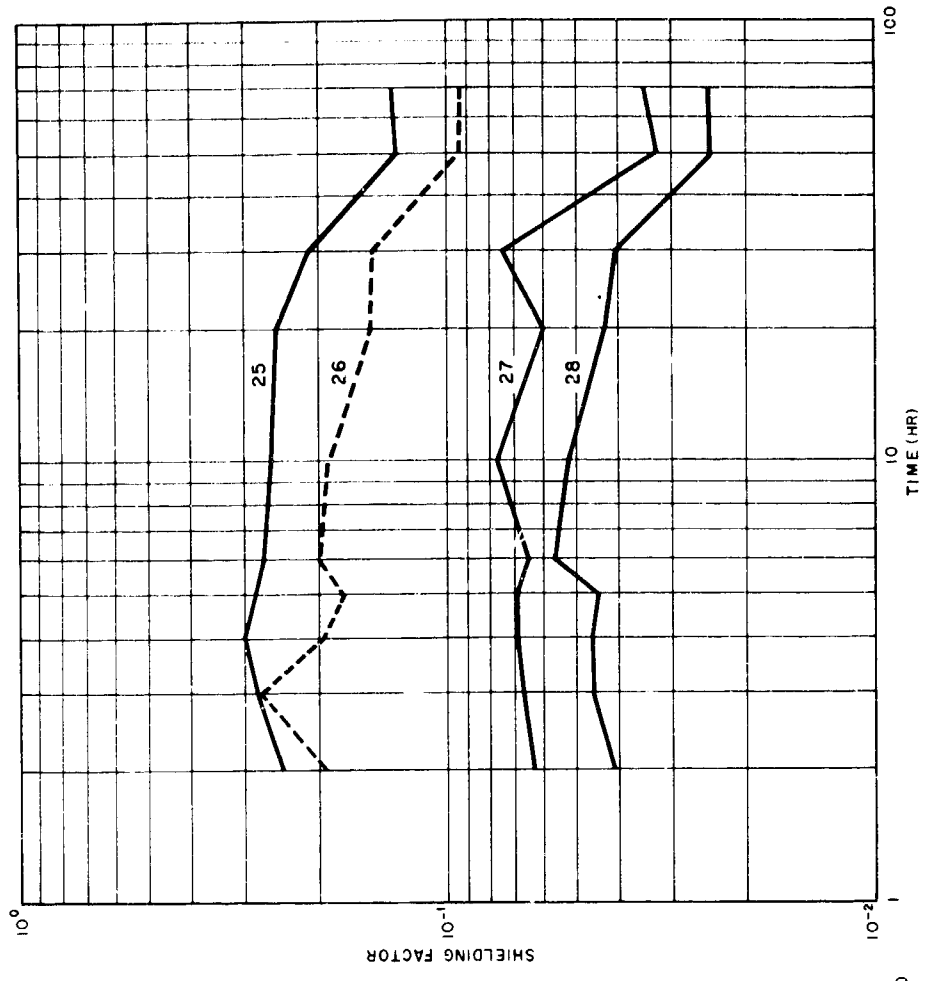

Figure 3.5 Shielding factors for Stations 25, 26, 27 and 28 on the YAG 40, Shot 4.

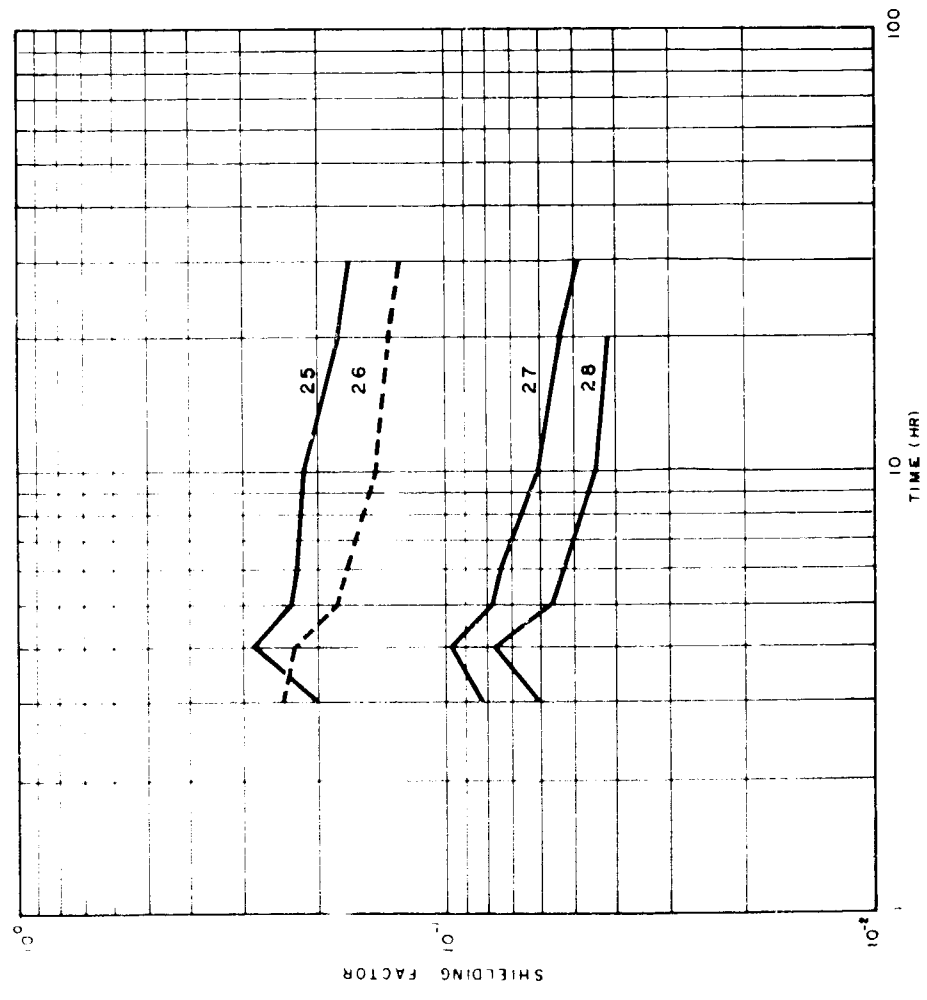

Figure 3.4 Shielding factors for Stations 25, 26, 27 and 28 on the YAG 40, Shot 2.

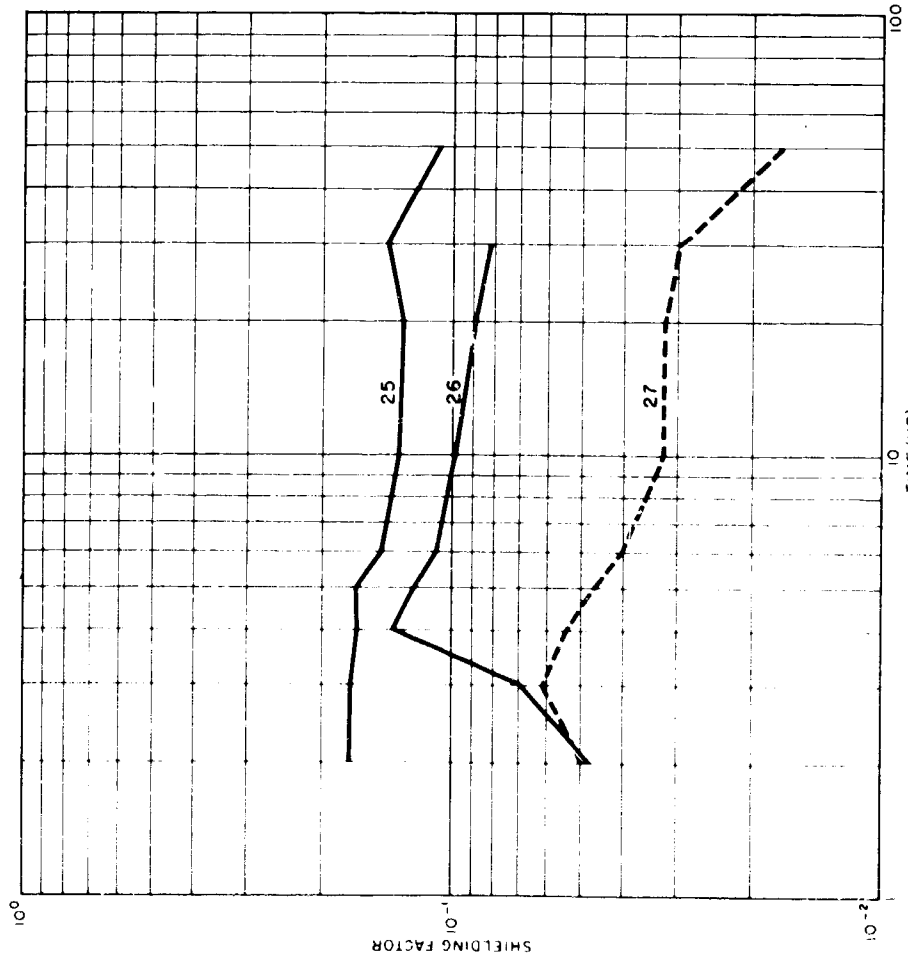

Figure 3.6 Shielding factors for Stations 25, 26, and 27 on the YAG 40, Shot 5.

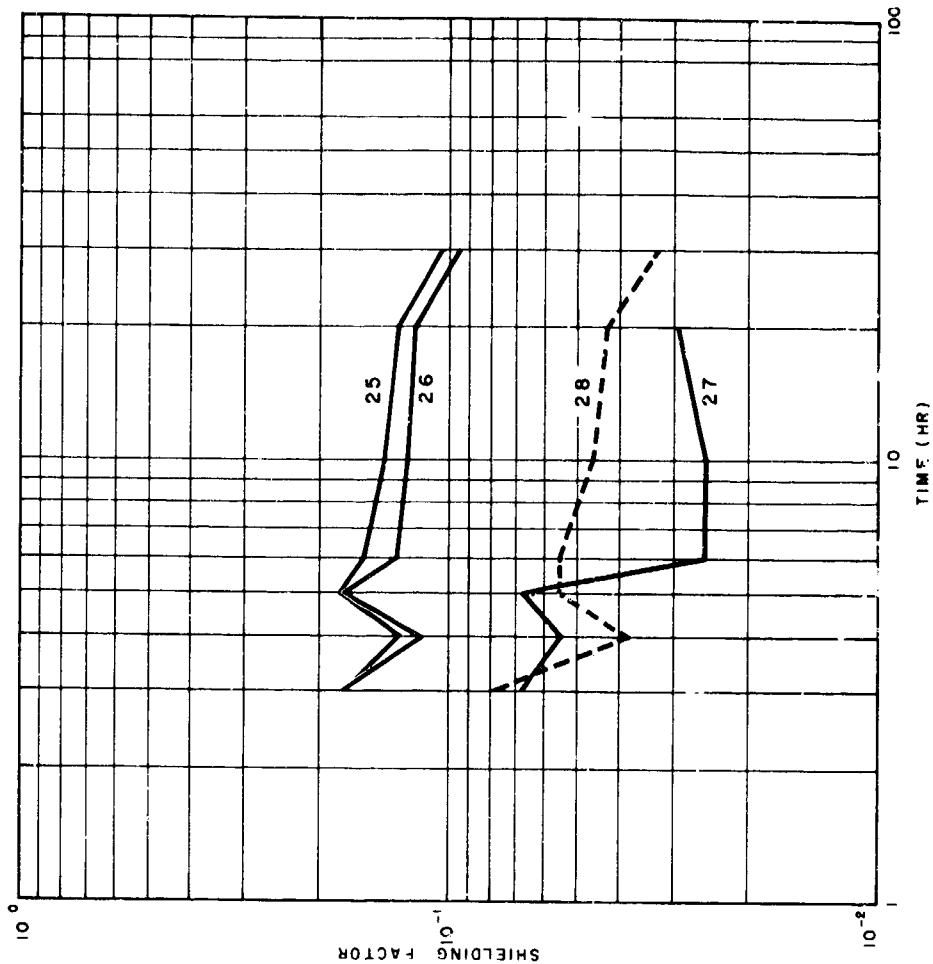

Figure 3.7 Shielding factors for Stations 25, 26, 27 and 28 on the YAG 39, Shot 2.

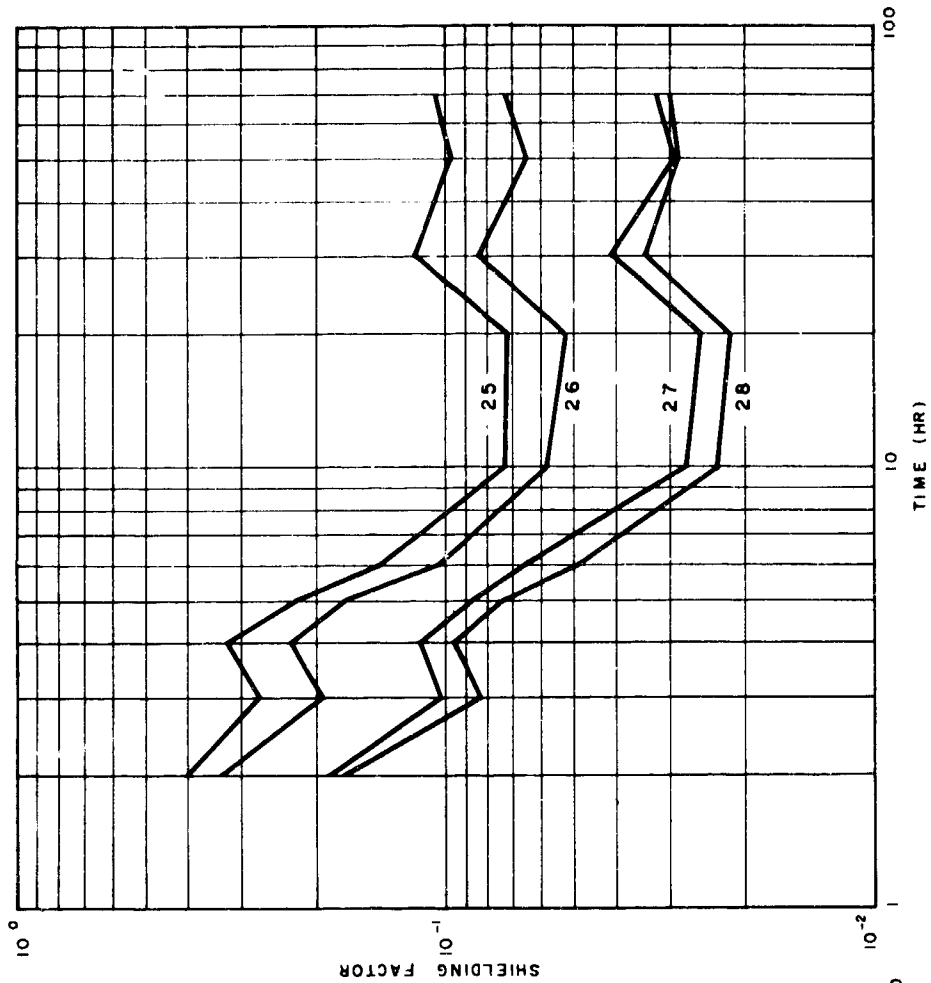

Figure 3.8 Shielding factors for Stations 25, 26, 27, and 28 on the YAG 39, Shot 4.

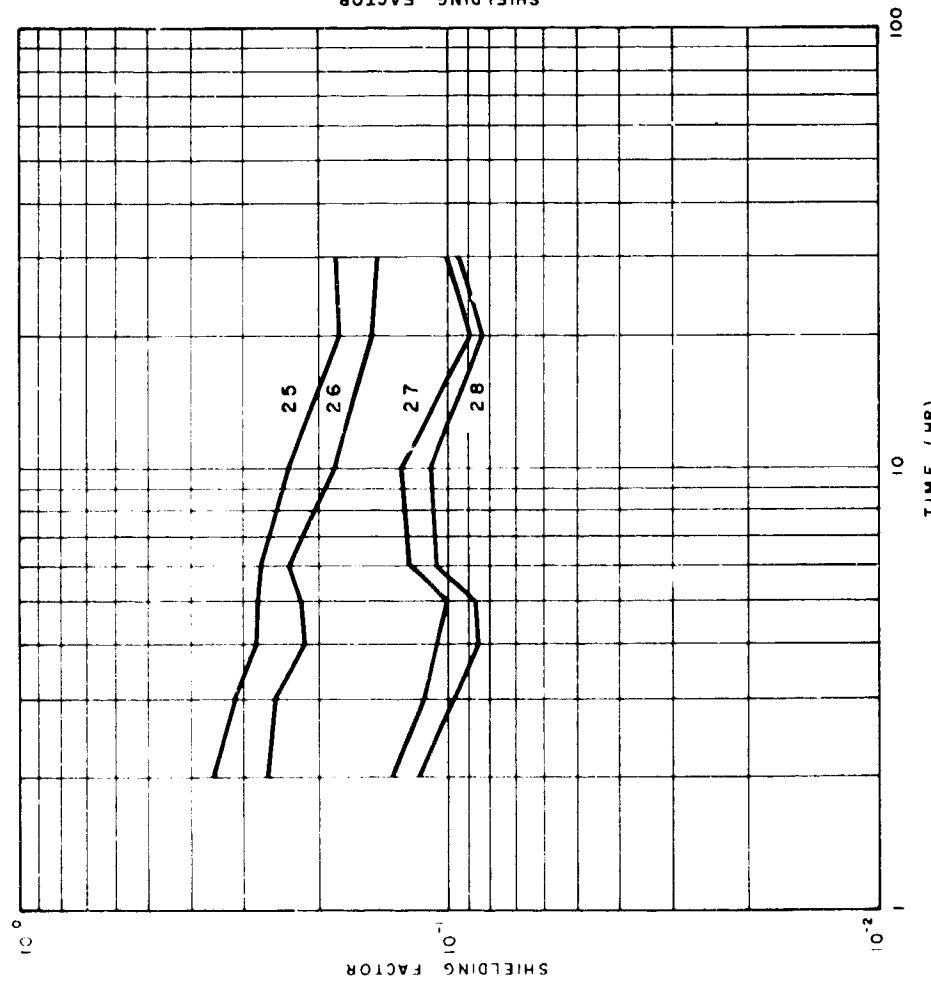

Figure 3.9 Shielding factors for Stations 25, 26, 27, and 28 on the YAG 39, Shot 5.

Ratios of dose rates from Station 7 to rates from Station 2, directly above on the simulated flight deck, are given in Figures 3.10 through 3.14.

In addition, on YAG 40 only, two steel plates about 6 ft sq were mounted symmetrically with centers  $10\frac{1}{2}$  ft on either side of the ship's centerline 3 ft above the second deck. Station 8 was located beneath the center of the 2-in.-thick plate and Station 6 beneath the 4-in.-thick plate. Ratios of dose rates at these stations to the rate from Station 2 are given in Figures 3.10 through 3.14.

The remaining below-deck location of primary interest to this study was in the instrument-recording room, hold No. 4, Station 64. The top of this room was a 12-in.-thick concrete slab. Ratios of dose rates from this station to rates from Station 68, the nearest location on the weather deck, and to Station 66, also above No. 4 hold but farther forward, are given in Figures 3.15 through 3.19.

One specific feature of the data for Station 64 on Shot 4 might be noted. This is the abrupt large increase in shielding factor for both ships beginning at about 7 hr. This increase can probably be attributed to the ships' courses intersecting a region of high water activity, since the course change at  $5\frac{1}{2}$  hr was expected to bring the ships back into the fallout region at about 7 to 8 hr.

Data from these studies generally indicate that the shielding factor: (1) decreased with increasing time; (2) decreased with increasing thickness of steel or with increasing distance between the detector and the upper deck; and (3) was greater for YAG 39 than for YAG 40 at comparable locations on the two ships, the difference becoming progressively greater with increasing thickness of steel or with increasing distance between the detector and the upper deck.

Survey measurements indicated a considerable spread in the dose rates measured within a given below-decks space. Arithmetic mean values and standard deviations were computed for each set of readings in each space. In most cases, the standard deviation was from 0.2 to 0.6 the mean value. Shielding factors determined from the survey measurements generally were larger in value than those determined from continuous dose-rate measurements at comparable times.

3.4.2 Superstructure Studies. Ratios of dose rates in superstructure compartments to rates above nearby open-deck surfaces are given in Figures 3.20 through 3.24. Because of the complex geometry and light construction of the superstructure, it is probable that various contaminated surfaces---such as the top of the house, exposed superstructure deck areas and nearby regions of the upper deck (main deck)---all contribute significantly to the radiation from activity deposited on weather surfaces.

Nevertheless, the shielding factors exhibit the same trends as for below-deck spaces, decreasing with increasing time and with increasing distance of the detector from the top of the house.

3.4.3 Steel-Pipe-Absorption Studies. Ratios of dose rates measured inside the steel pipes mounted on No. 2 hatch to the rates for the similar unshielded detector, Station 15, are given in Figures 3.25 through 3.32.

Absorption curves were made from these data for each shot and each ship. In these curves, the shielding factor was plotted on a logarithmic scale against the pipe thickness on a linear scale. Despite the hetero-

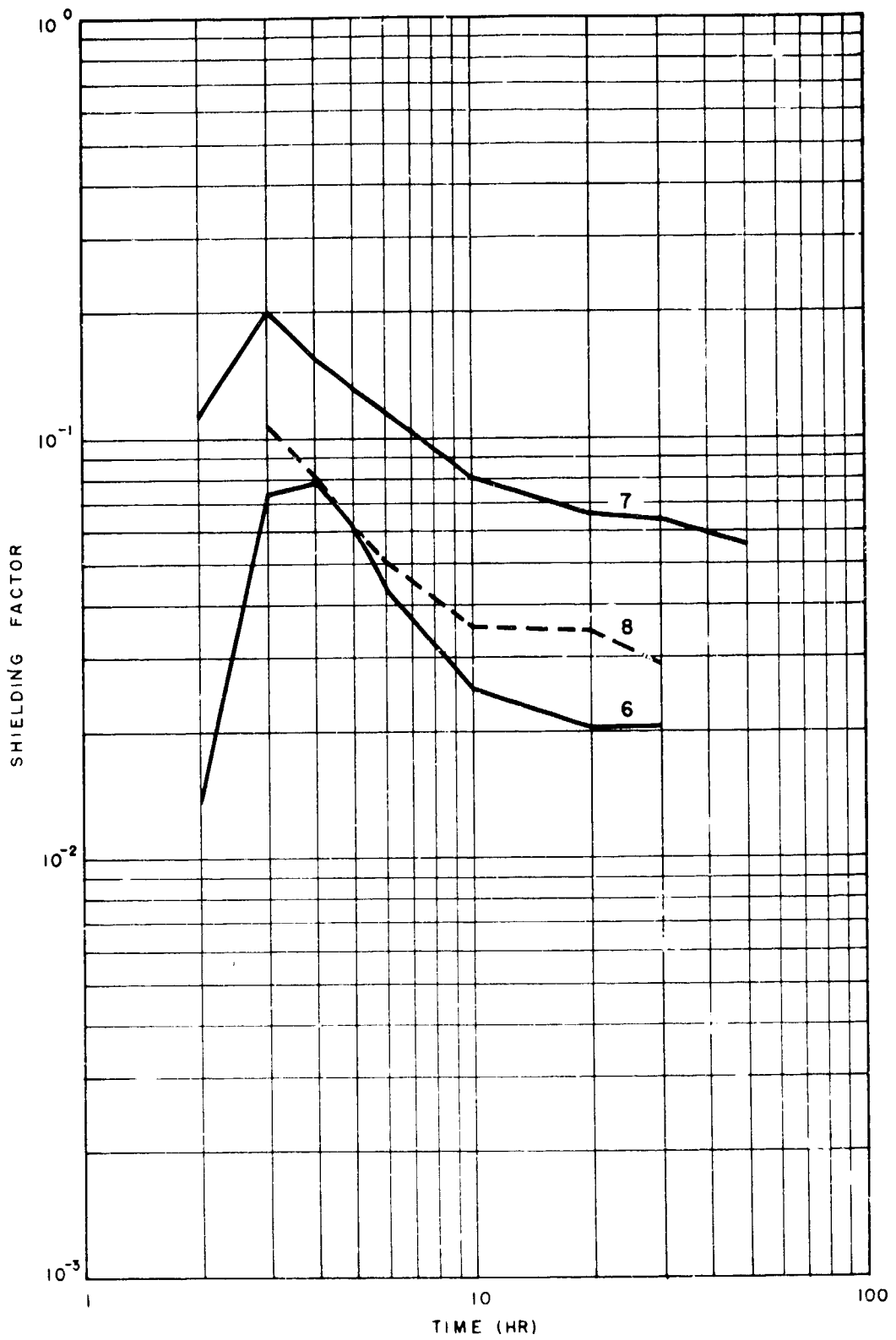

Figure 3.10 Shielding factors for Stations 6, 7, and 8 on the YAG 40, Shot 2.

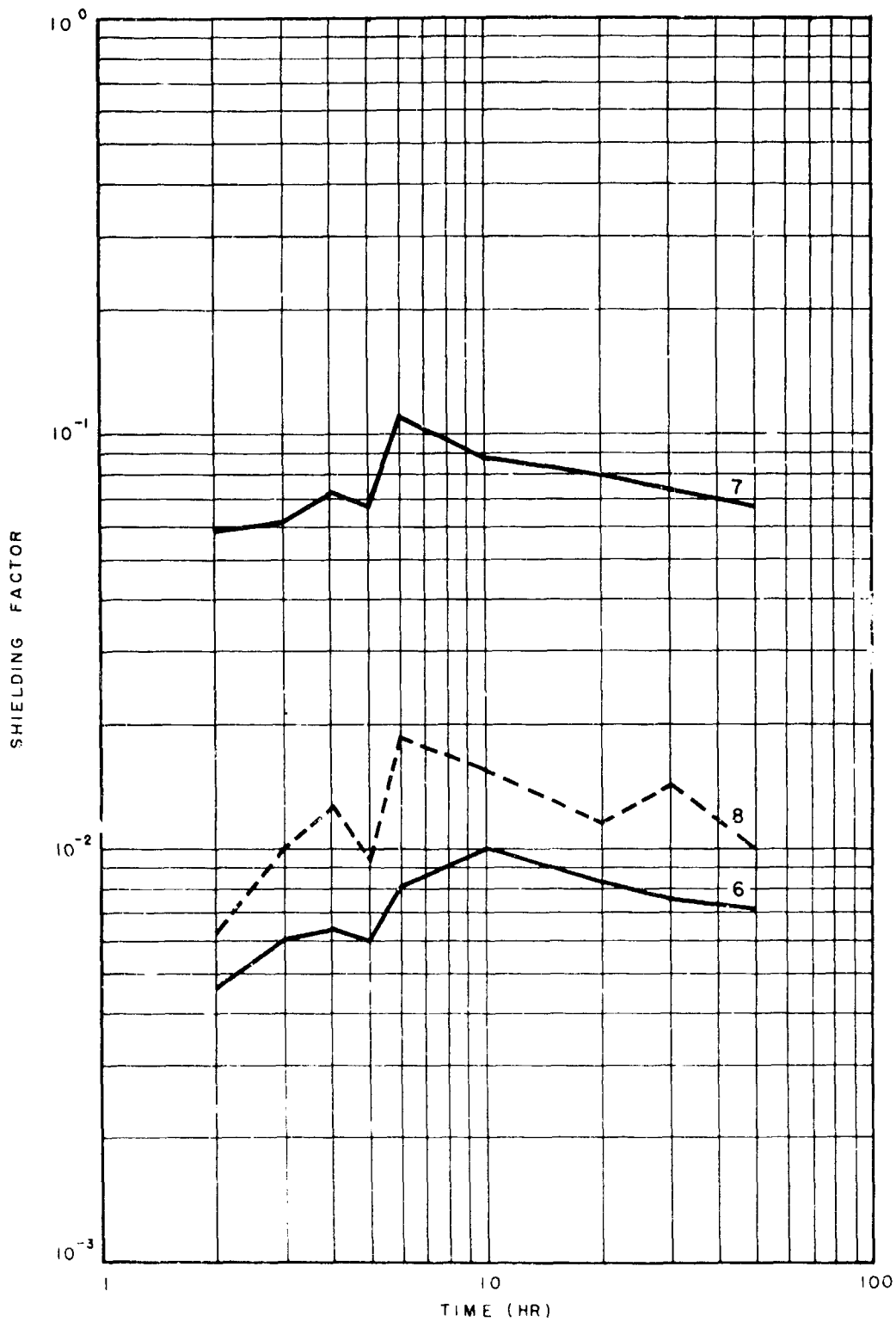

Figure 3.11 Shielding factors for Stations 6, 7, and 8 on the YAG 40, Shot 4.

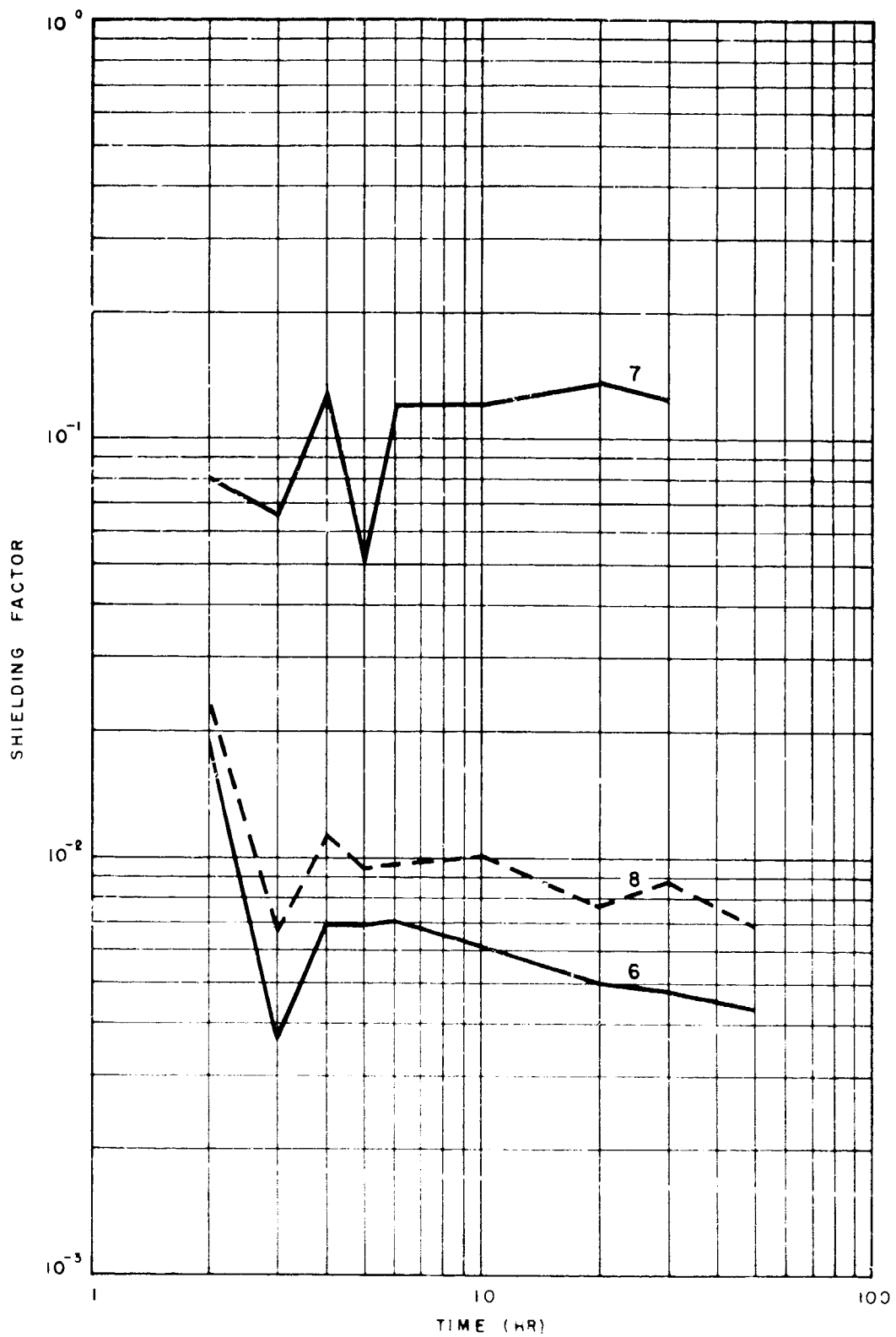

Figure 3.12 Shielding factors for Stations 6, 7, and 8 on the YAG 40, Shot 5.

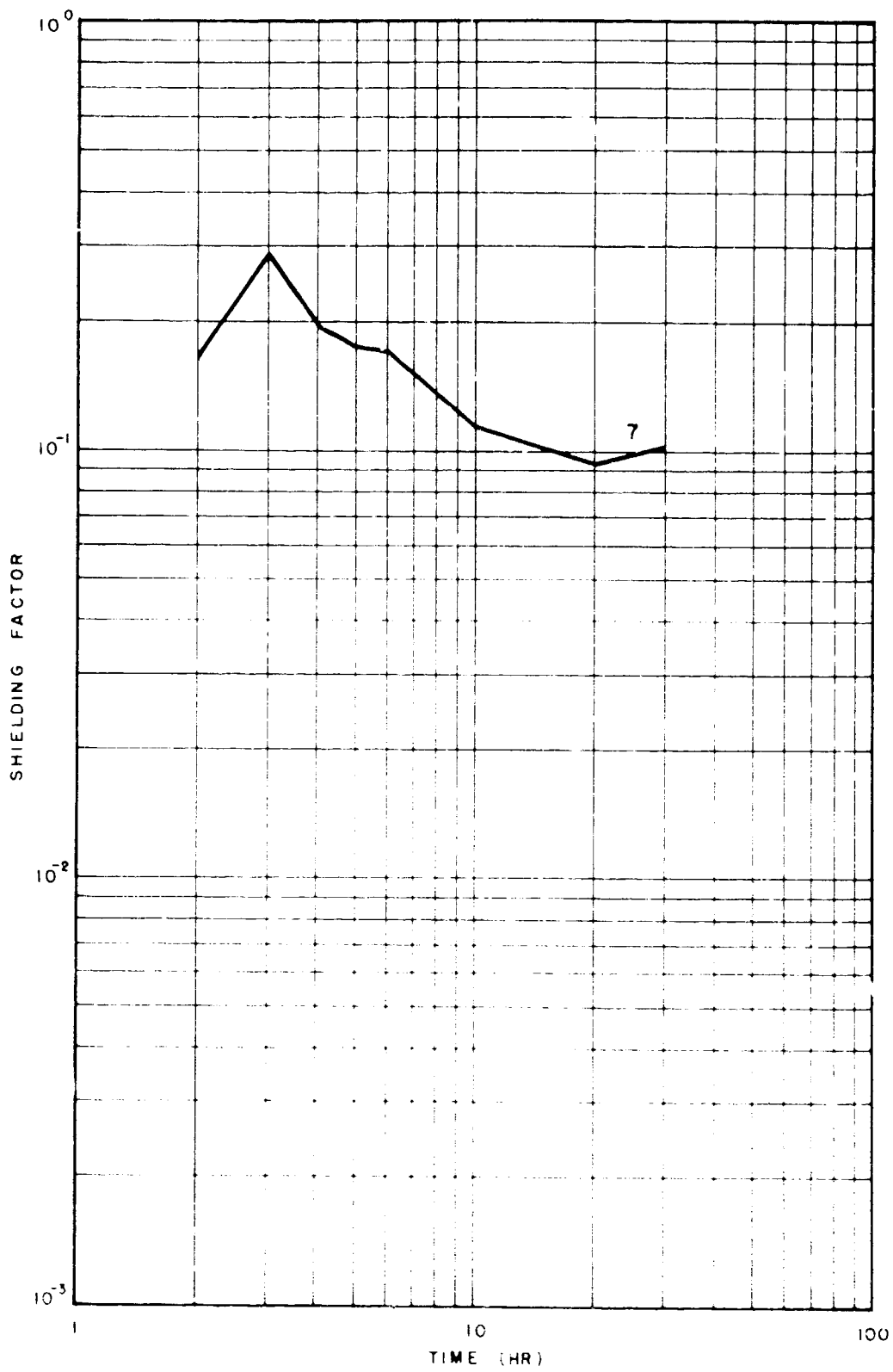

Figure 3.13 Shielding factors for Station 7 on the YAG 40, Shot 4.



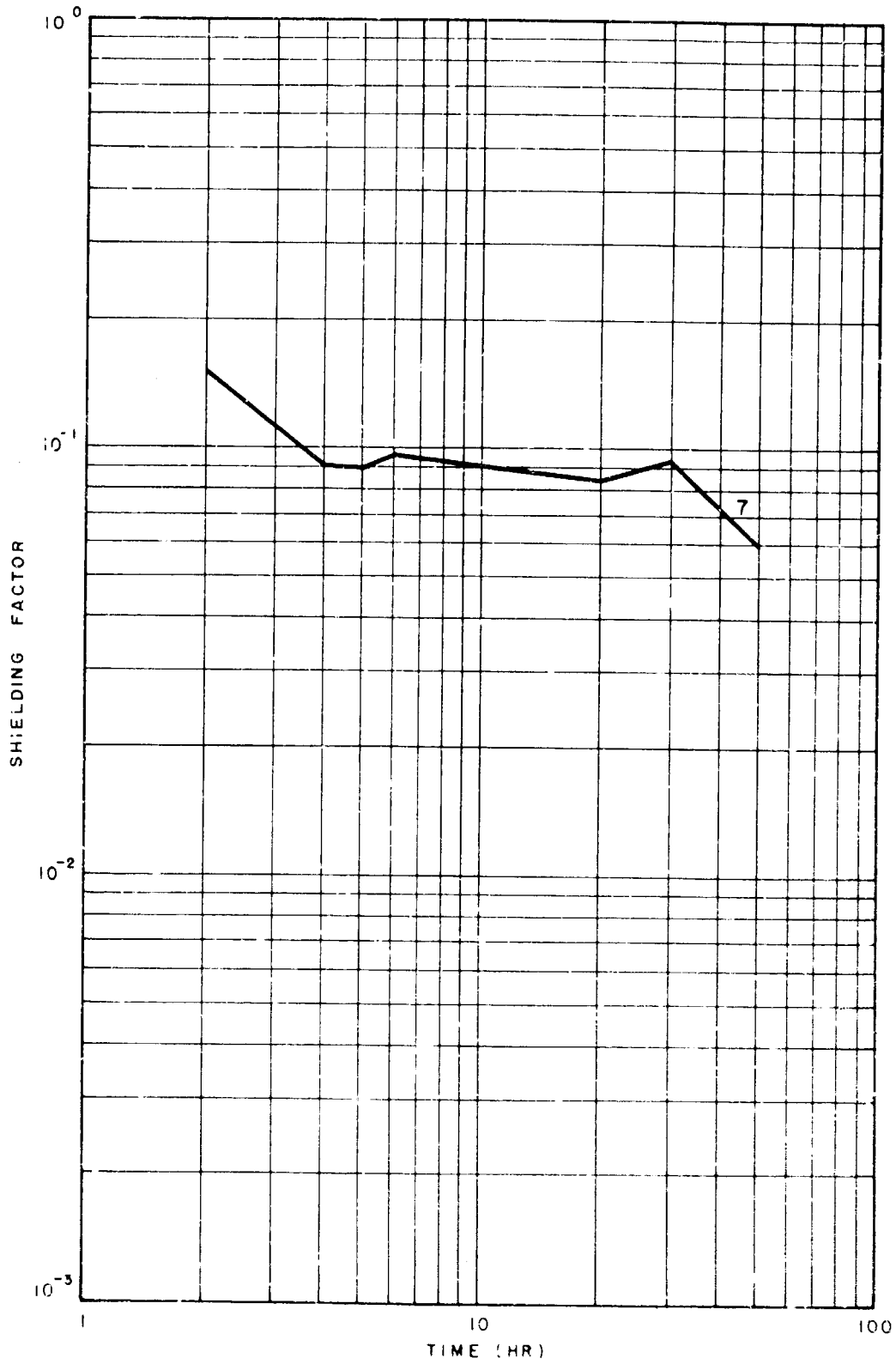

Figure 3.14 Shielding factors for Station 7 on the YAG 40, Shot 5.

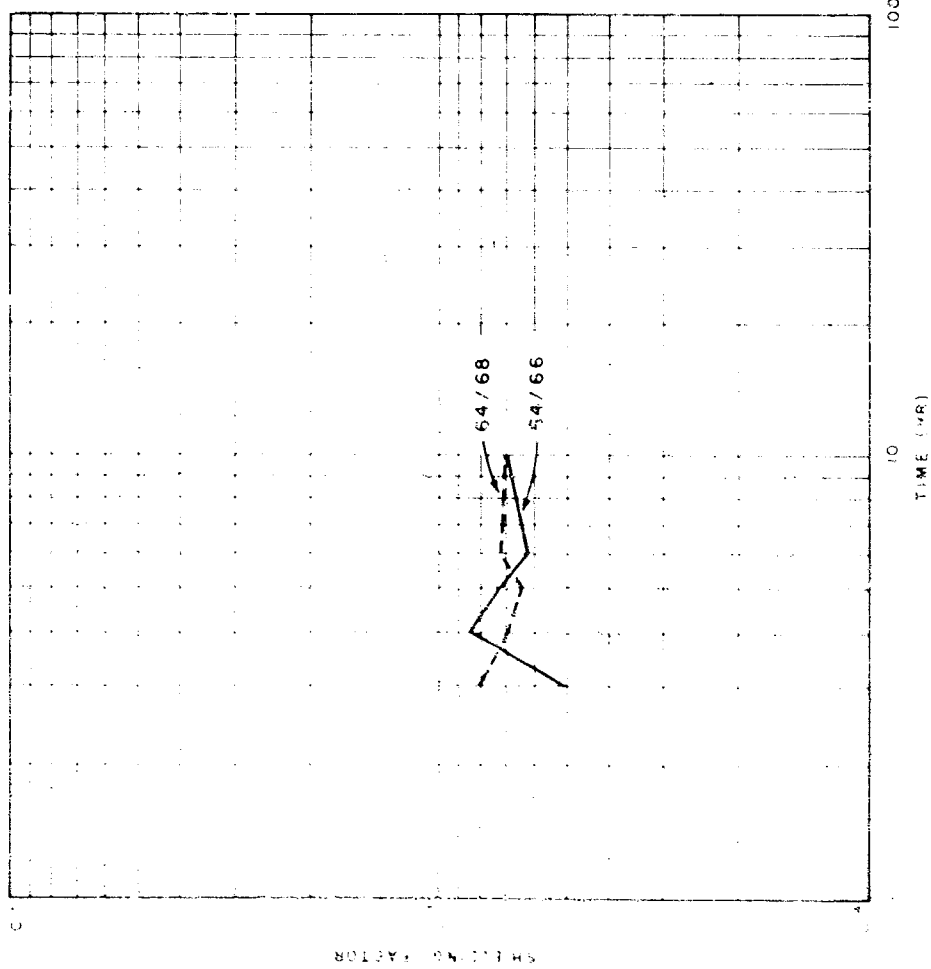

Figure 3.15 Shielding factors for Station 64 on the YAG 40, Shot 2.

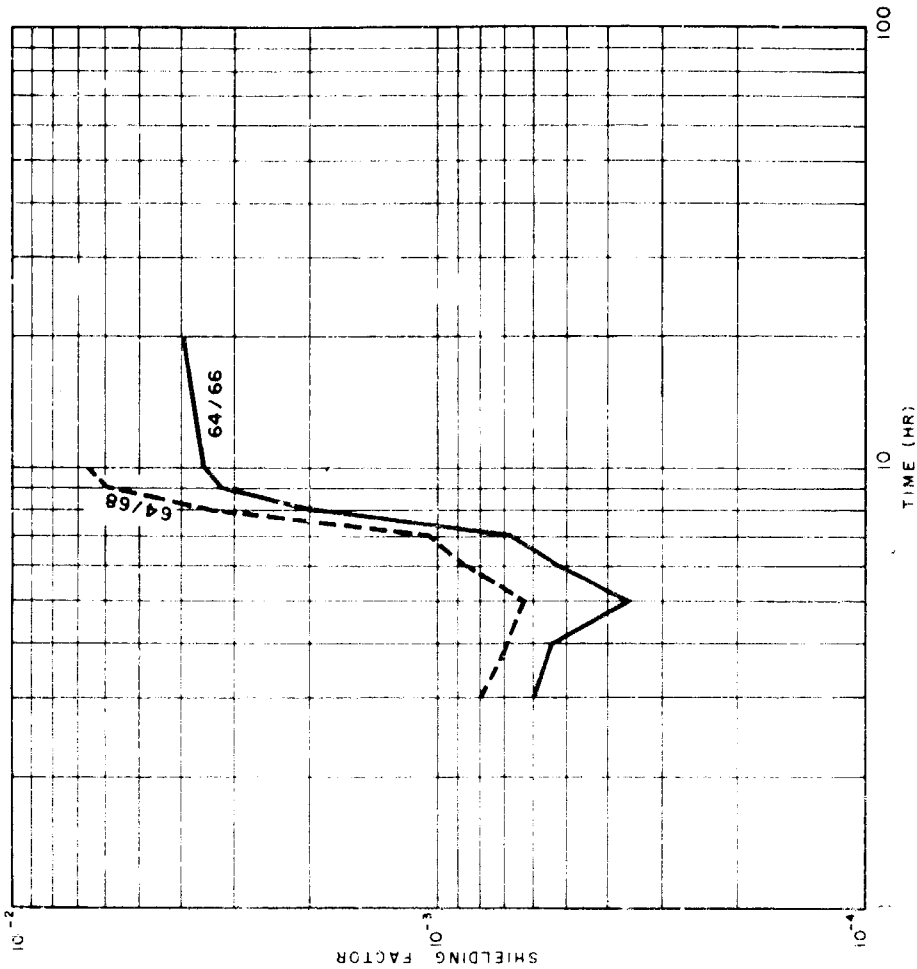

Figure 3.16 Shielding factors for Station 64 on the YAG 40, Shot 4.

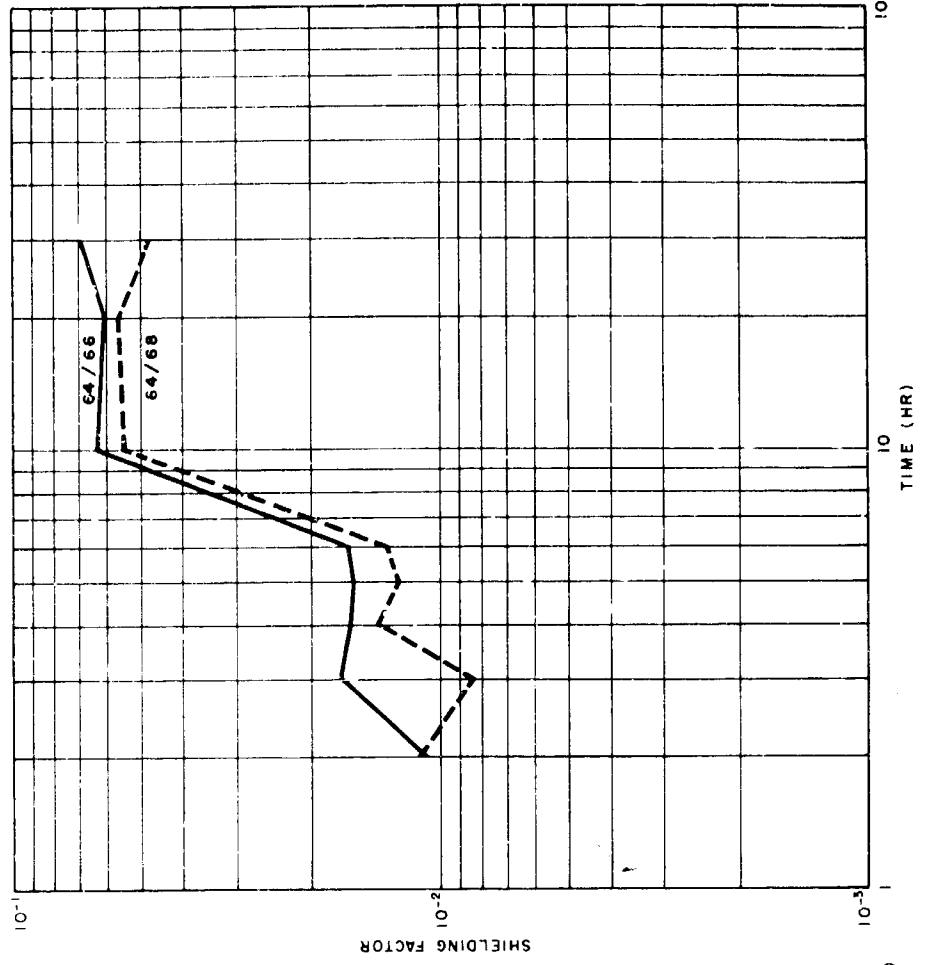

Figure 3.17 Shielding factors for Station 64 on the YAG 40, Shot 5.

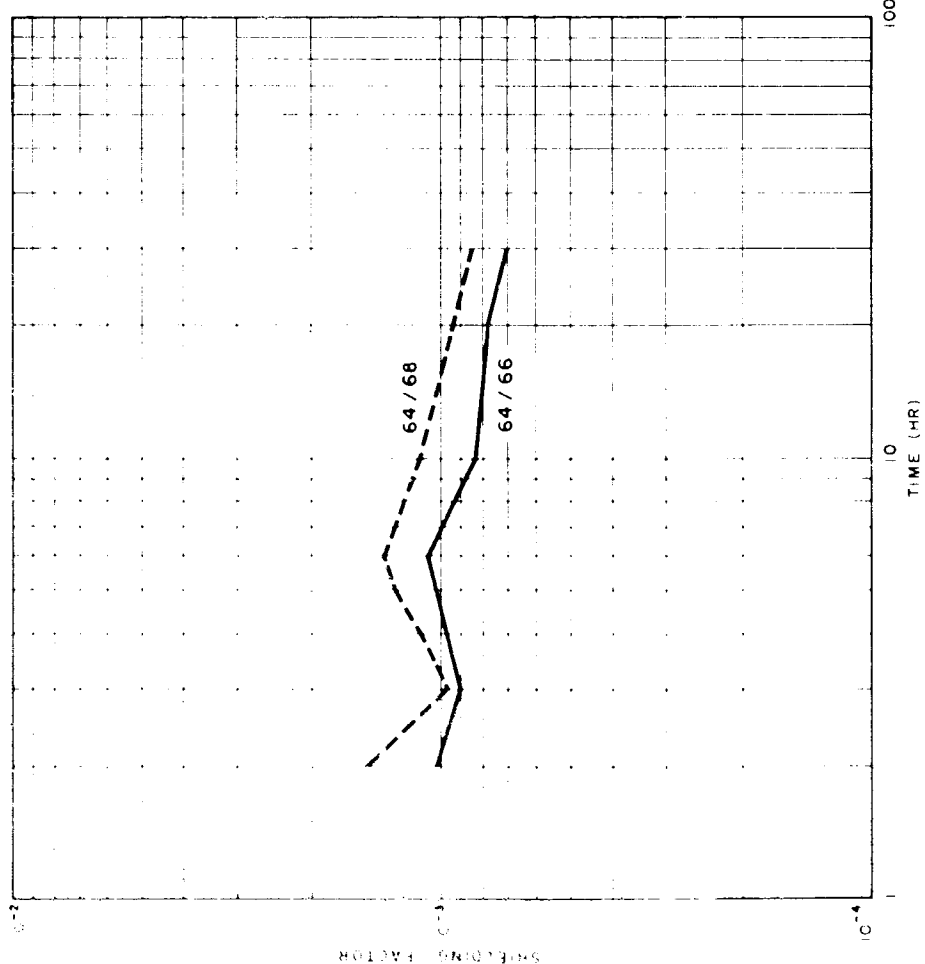

Figure 3.18 Shielding factors for Station 64 on the YAG 39, Shot 4.

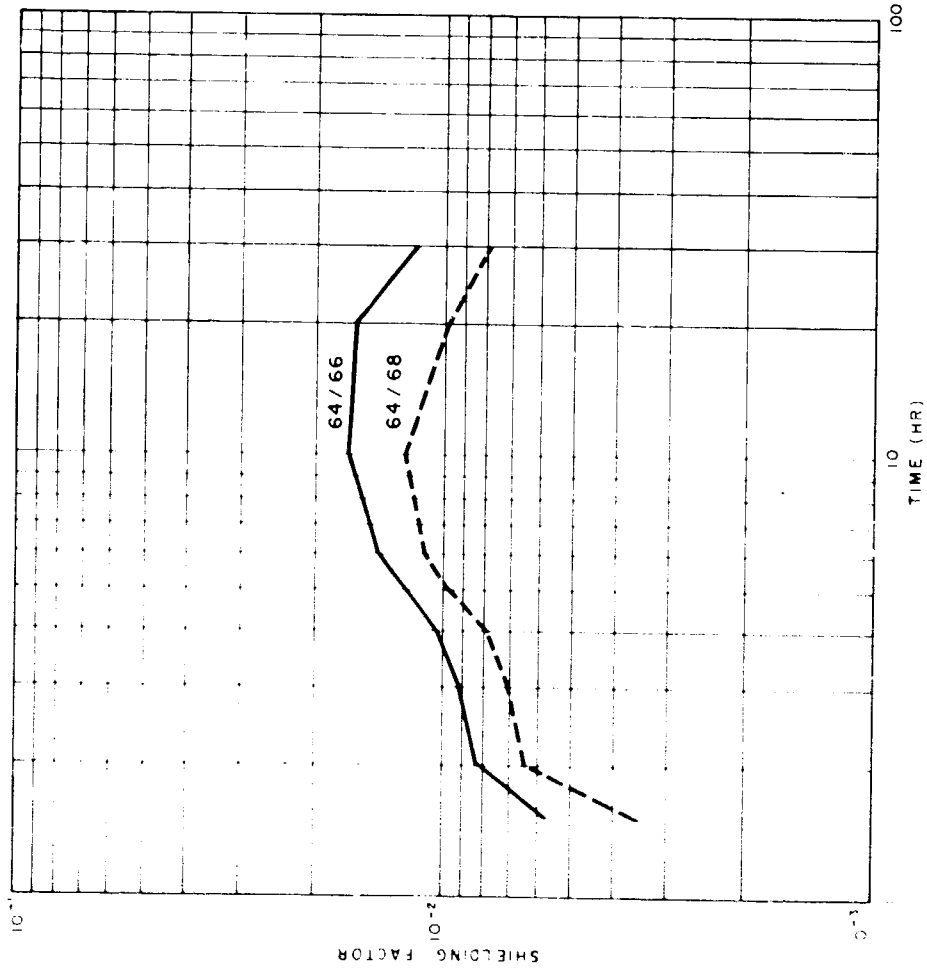

Figure 3.19 Shielding factors for Station 64 on the YAG 39, Shot 5.

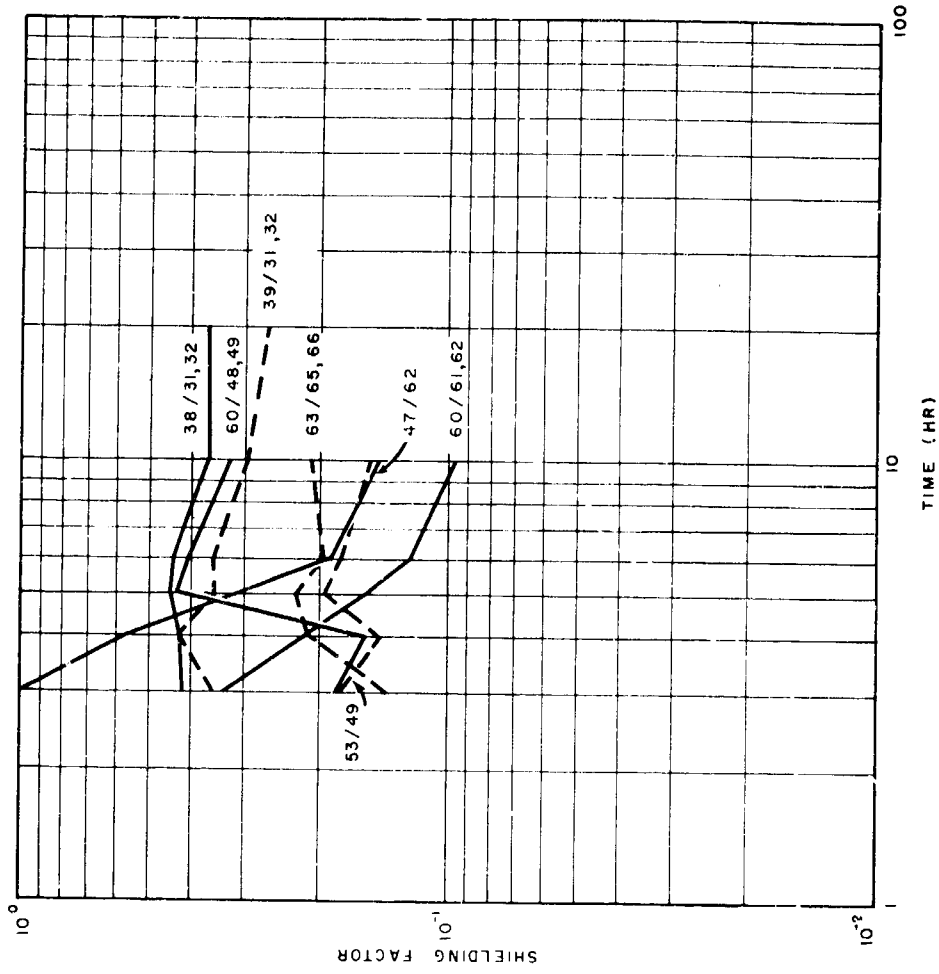

Figure 3.20 Shielding factors for superstructure stations on the YAG 40, Shot 2.

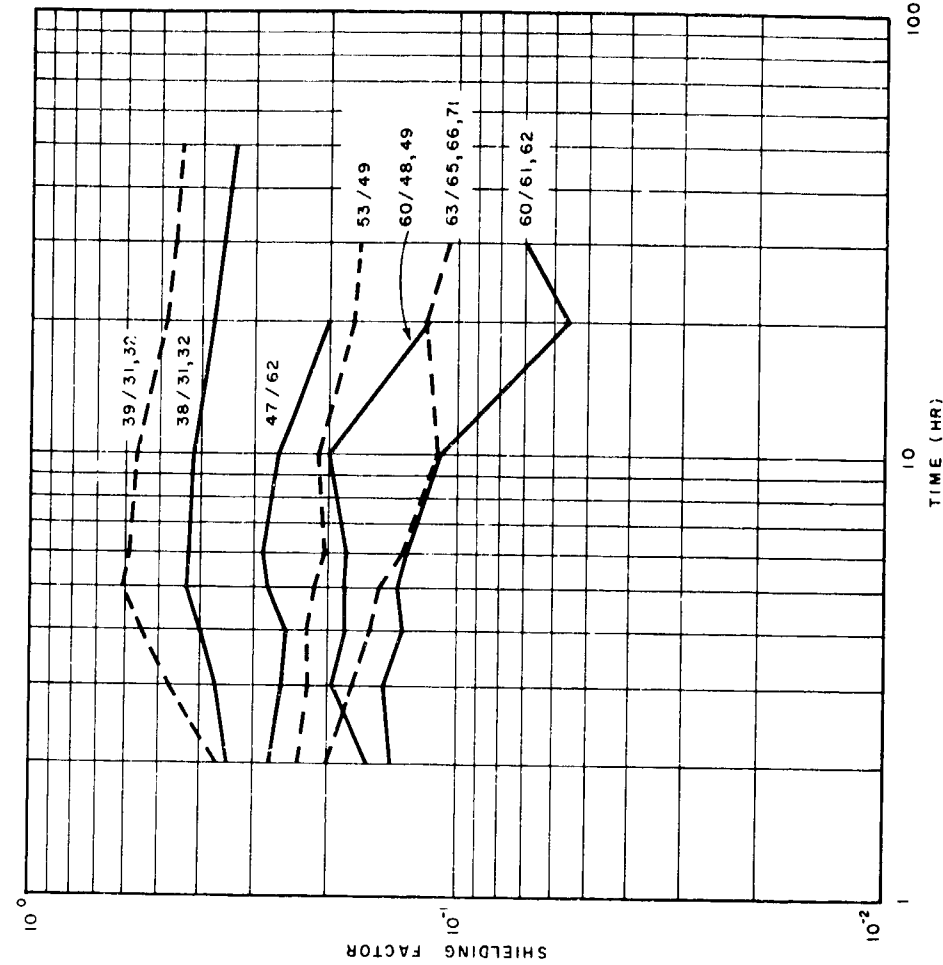

Figure 3.21 Shielding factors for superstructure stations on the YAG 40, Shot 4.

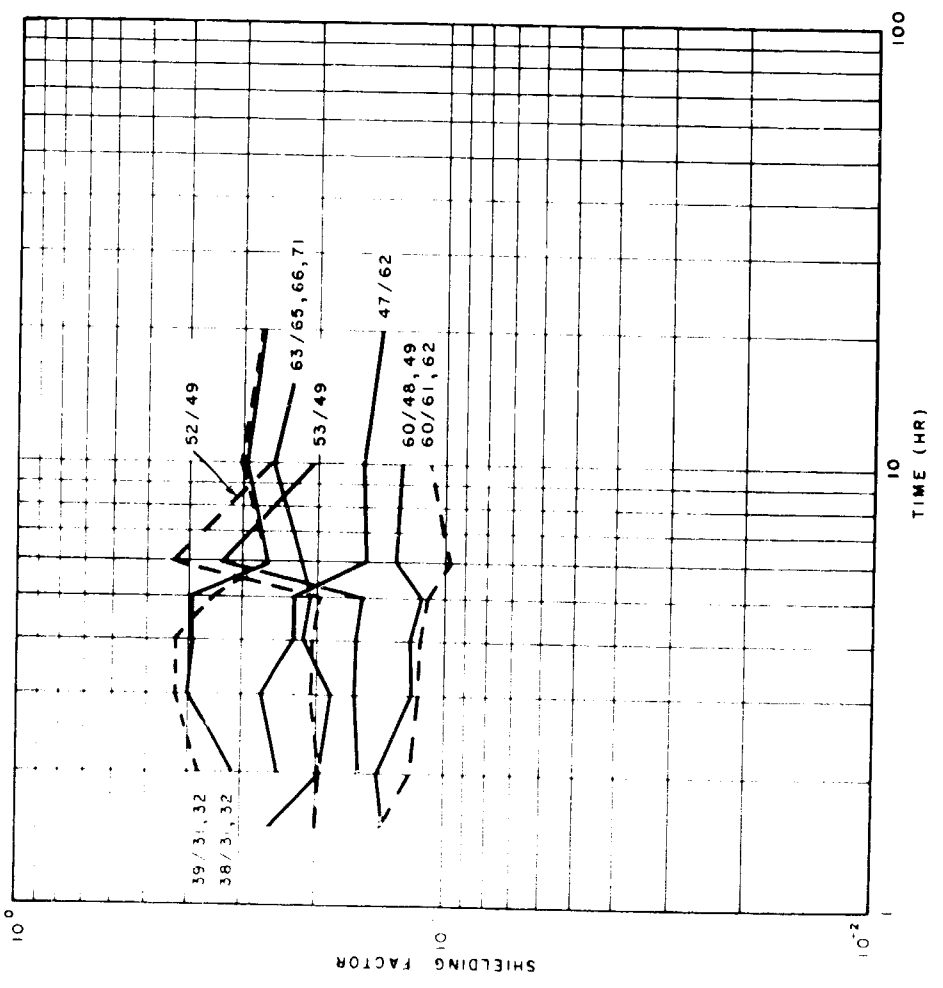

Figure 3.22 Shielding factors for superstructure stations on the YAG 40, Shot 5.

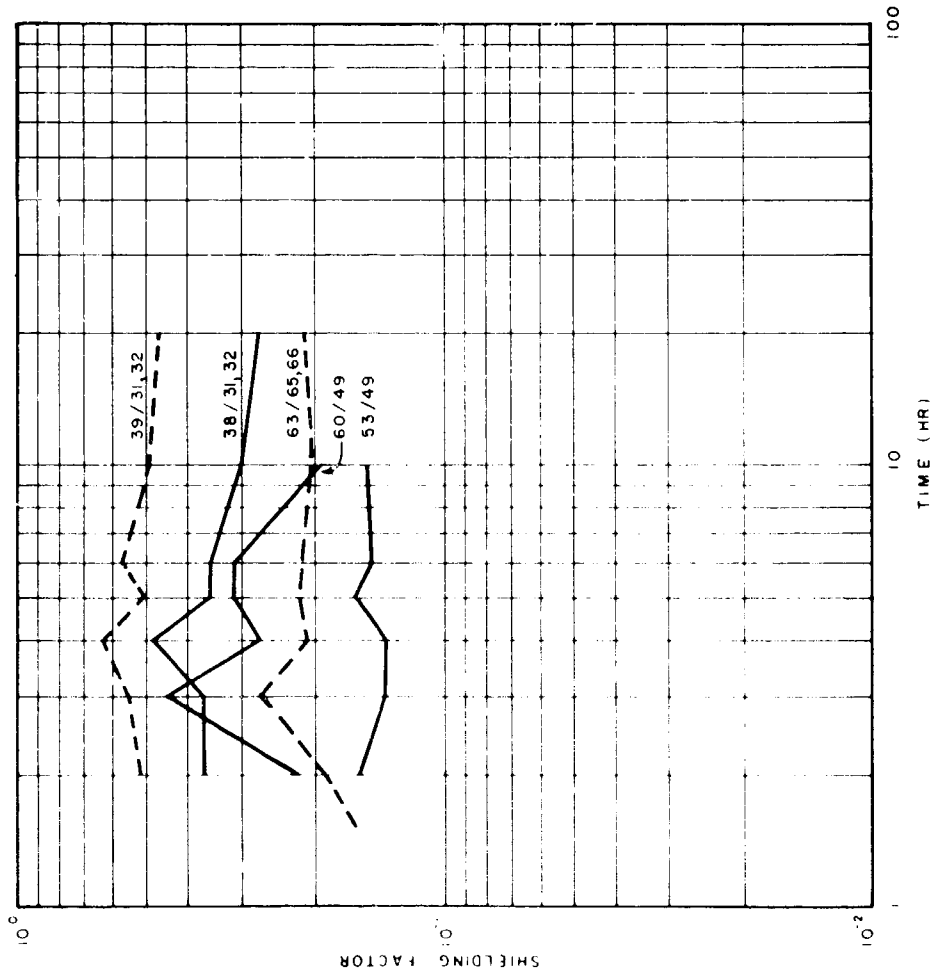

Figure 3.23 Shielding factors for superstructure stations on the YAG 39, Shot 4.

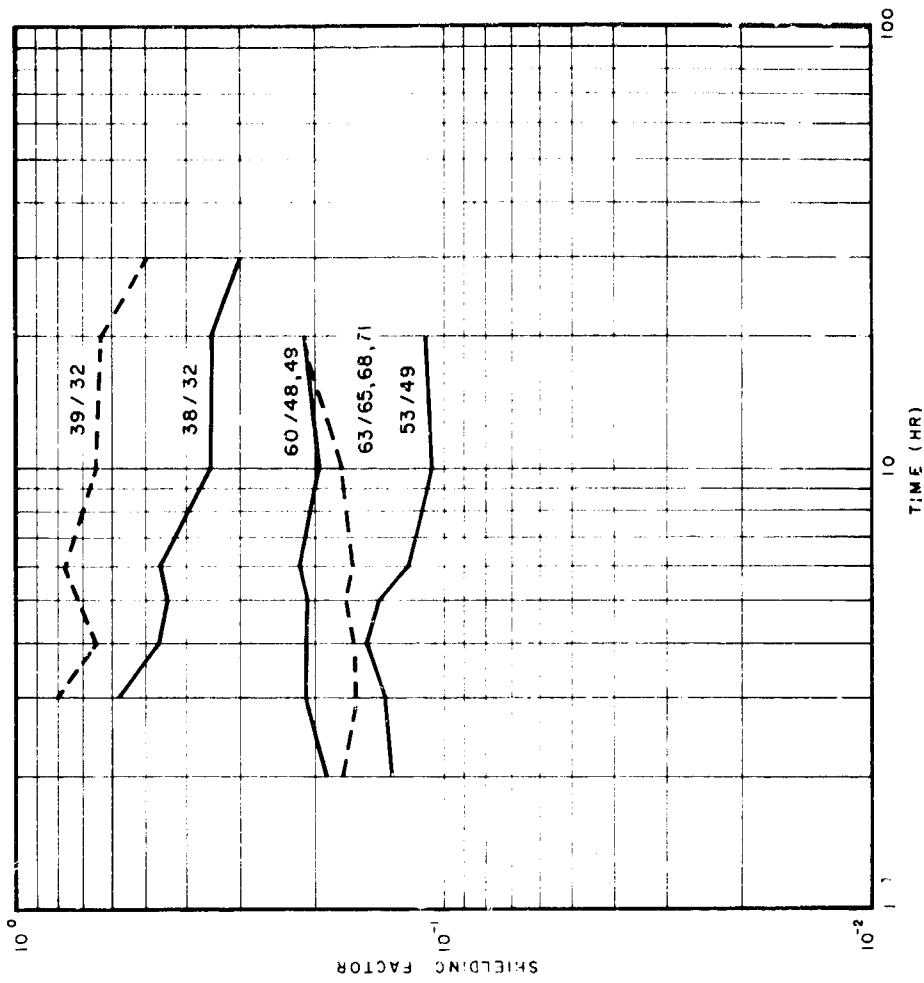

Figure 3.24 Shielding factors for superstructure stations on the YAG 39, Shot 5.

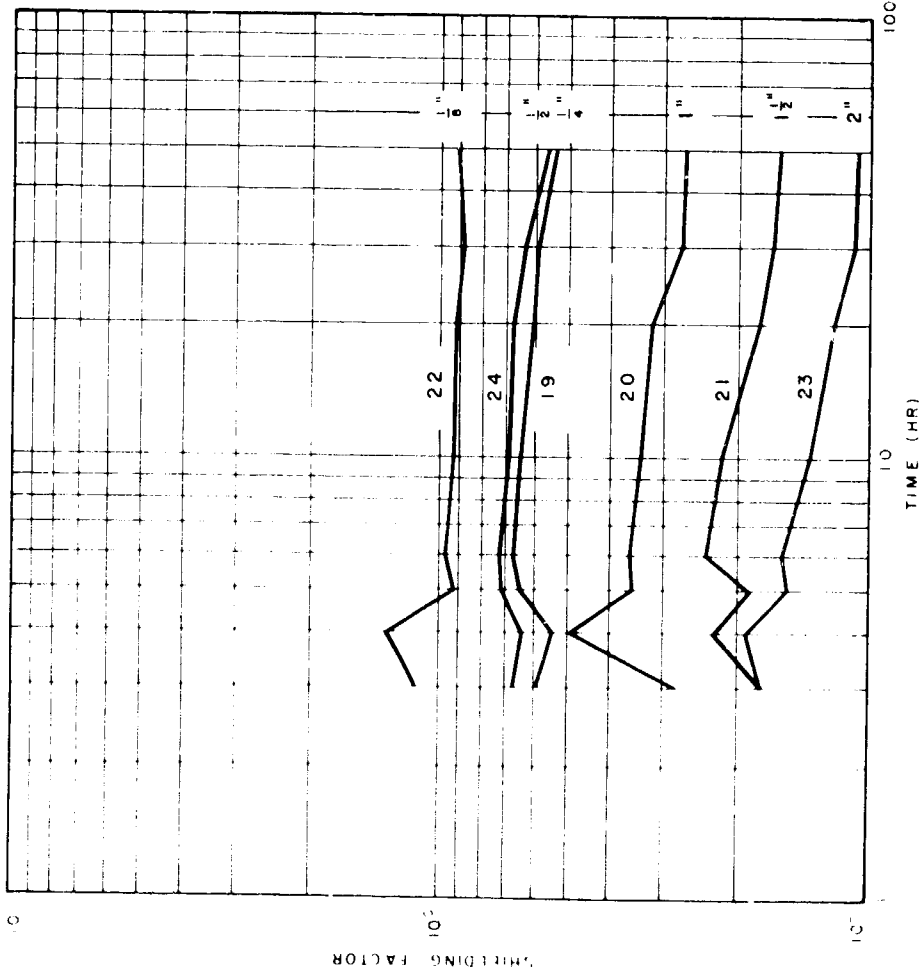

Figure 3.25 Ratio of dose rates on shielded instruments to rate on unshielded instrument (No. 15) YAG 40, Shot 2.

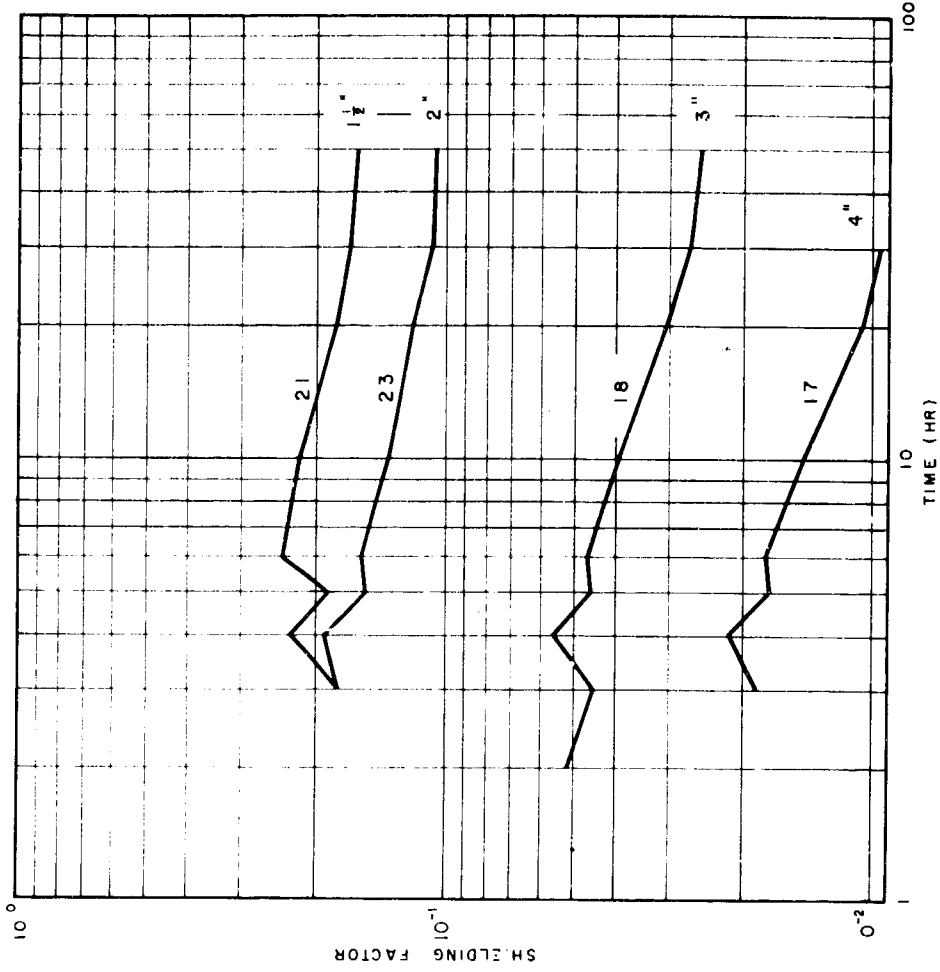

Figure 3.26 Ratios of dose rates on shielded instruments to rate on unshielded instrument (No. 15), YAG 40, Shot 2.

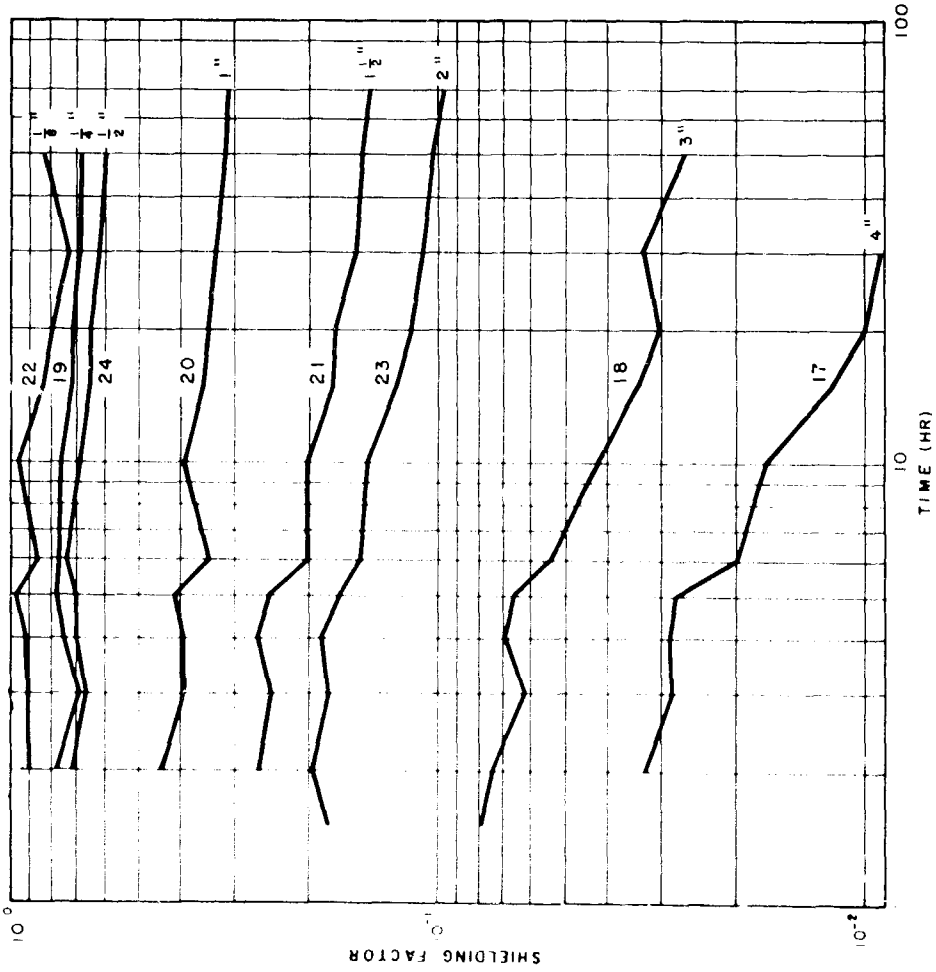

Figure 3.27 Ratios of dose rates on shielded instruments to rate on unshielded instrument (No. 15) YAG 40, Shot 4.

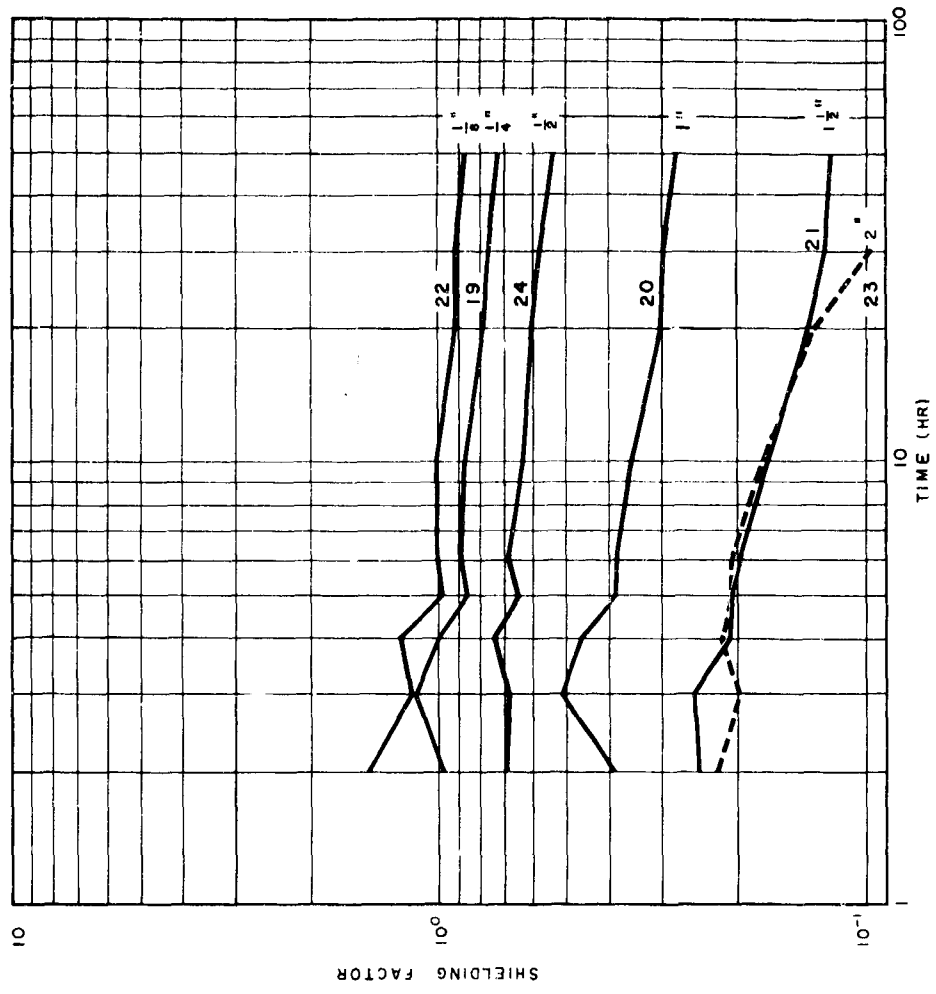

Figure 3.28 Ratios of dose rates on shielded instruments to rate on unshielded instrument (No. 15) YAG 40, Shot 5.



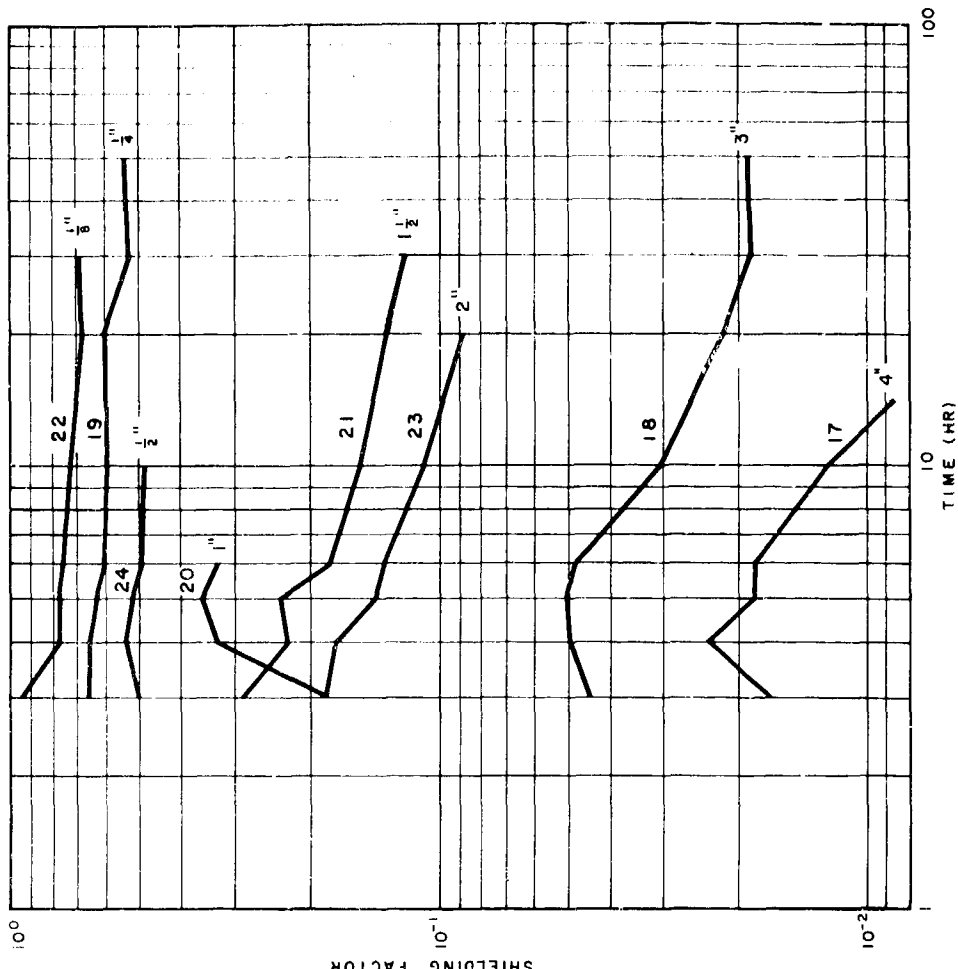

Figure 3.29 Ratios of dose rates on shielded instruments to rate on unshielded instrument (No. 15) YAG 40, Shot 5.

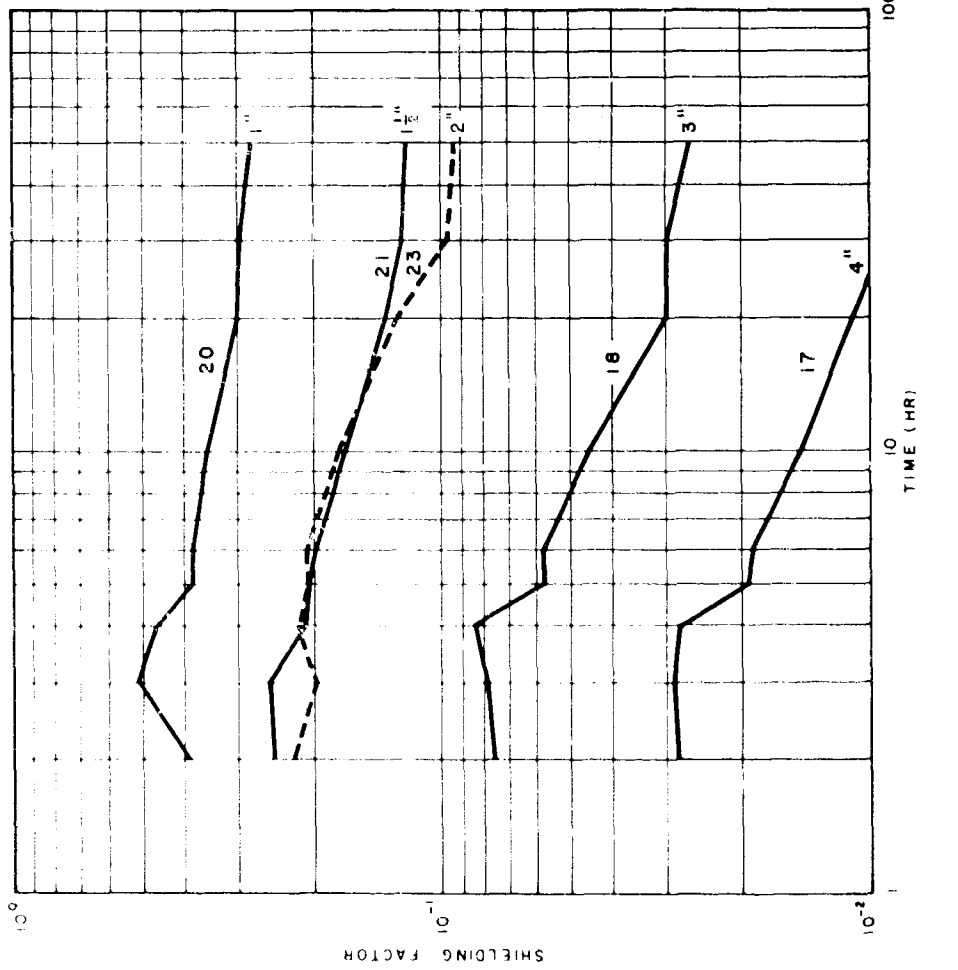

Figure 3.30 Ratios of dose rates on shielded instruments to rate on unshielded instrument (No. 15) YAG 39, Shot 2.

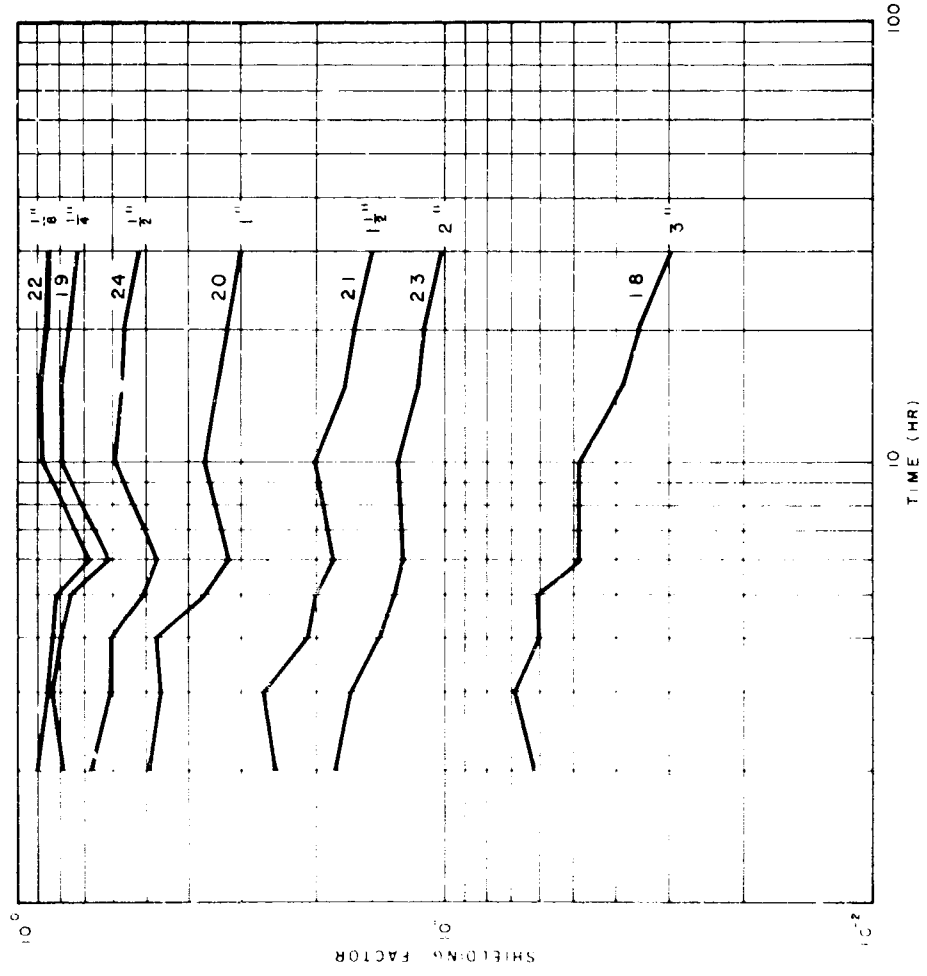

Figure 3.31 Ratios of rate on shielded instrument to rate on unshielded instrument (No. 15) YAG 39, Shot 4.

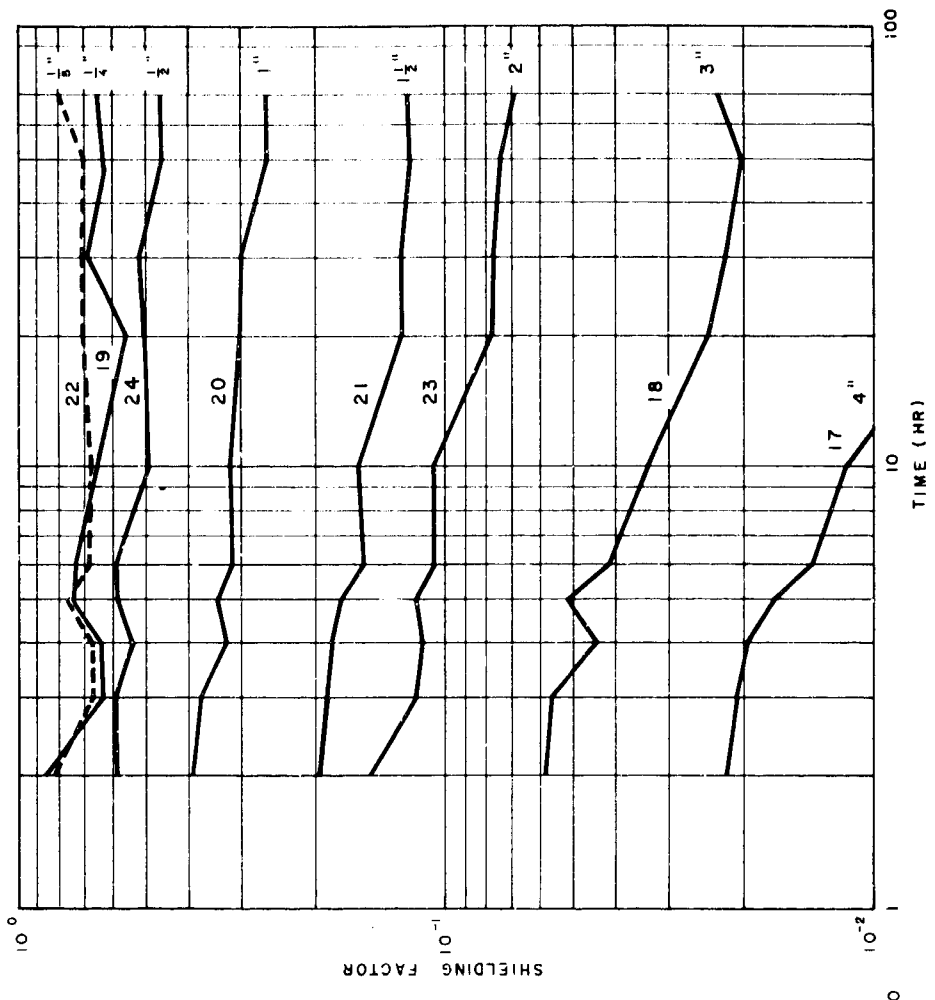

Figure 3.32 Ratio of rate on shielded instrument to rate on unshielded instrument (No. 15) YAG 39, Shot 5.

geneous energy spectrum of the radiation, the data points generally fell quite close to straight lines, indicating an exponential attenuation of the form  $F = e^{-\bar{\mu}z}$  where  $z$  is the thickness of steel. Here  $\bar{\mu}$  is an apparent absorption coefficient and should be smaller than the usually quoted values, because the detectors also measure the radiation scattered by the pipe walls.

Values of  $\bar{\mu}$  for each shot computed by the method of least squares, as well as overall averages, are given in Table 3.1, for times between 2 hr

TABLE 3.1 APPARENT ABSORPTION COEFFICIENTS,  $\bar{\mu}$ , FROM STEEL PIPE STUDIES

Ship	Shot	Time after Shot (hr)							
		2	3	6	10	20	30	50	70
YAG 39	4	0.915	0.891	0.953	1.015	1.121	1.179	-	-
	5	0.951	0.931	1.047	1.082	1.205	1.255	1.263	1.246
YAG 40	2	-	0.999	1.015	1.061	1.141	1.172	1.181	-
	4	0.873	0.891	0.981	1.043	1.149	1.110	1.194	1.196
	5	0.929	0.928	0.994	1.061	1.136	1.201	1.228	-
Arithmetic Mean		0.917	0.928	0.998	1.052	1.150	1.185	1.217	1.221
Standard Deviation Mean		0.036	0.044	0.035	0.024	0.028	0.042	0.030	0.034

and 70 hr. The precision of the data is quite high, indicating little variation in absorption characteristics from shot to shot or from ship to ship. There is a slight tendency for  $\bar{\mu}$  to be greater for Shot 5 than for Shot 4 on both ships and, on Shot 5, for  $\bar{\mu}$  on YAG 39 to be greater than for YAG 40.

Absorption curves for various times, based on the average values of  $\bar{\mu}$ , are shown in Figure 3.33, and  $\bar{\mu}$  is plotted as a function of time in Figure 3.34. Both these figures clearly show the increase in attenuation with increasing time, indicative of a softening of the radiation energy spectrum.

#### 3.4.4 Comparison of Observed and Computed Shielding Factors.

Values of the overall shielding factor,  $F$ , for below-deck stations are plotted as a function of the total thickness of steel between the detector and the upper surface of the upper deck at various times in Figures 3.35 through 3.39. In these plots, the 12-in. concrete slab over the recording room is assumed to be equivalent to 3.7 in. of steel on an equal-mass-per-unit-area basis. Readings under the 2-in.-thick steel plate have been modified to more nearly correspond with the expected reading under a 2-in.-thick deck by subtracting from them the readings under the 4-in. plate. This procedure was intended to eliminate the contribution of radiations not traveling through the plate because of its small size (see Appendix B).

Computed curves of the shielding factor for activity uniformly deposited on the upper deck are also shown in these figures. The method of calculation is described in Appendix B.

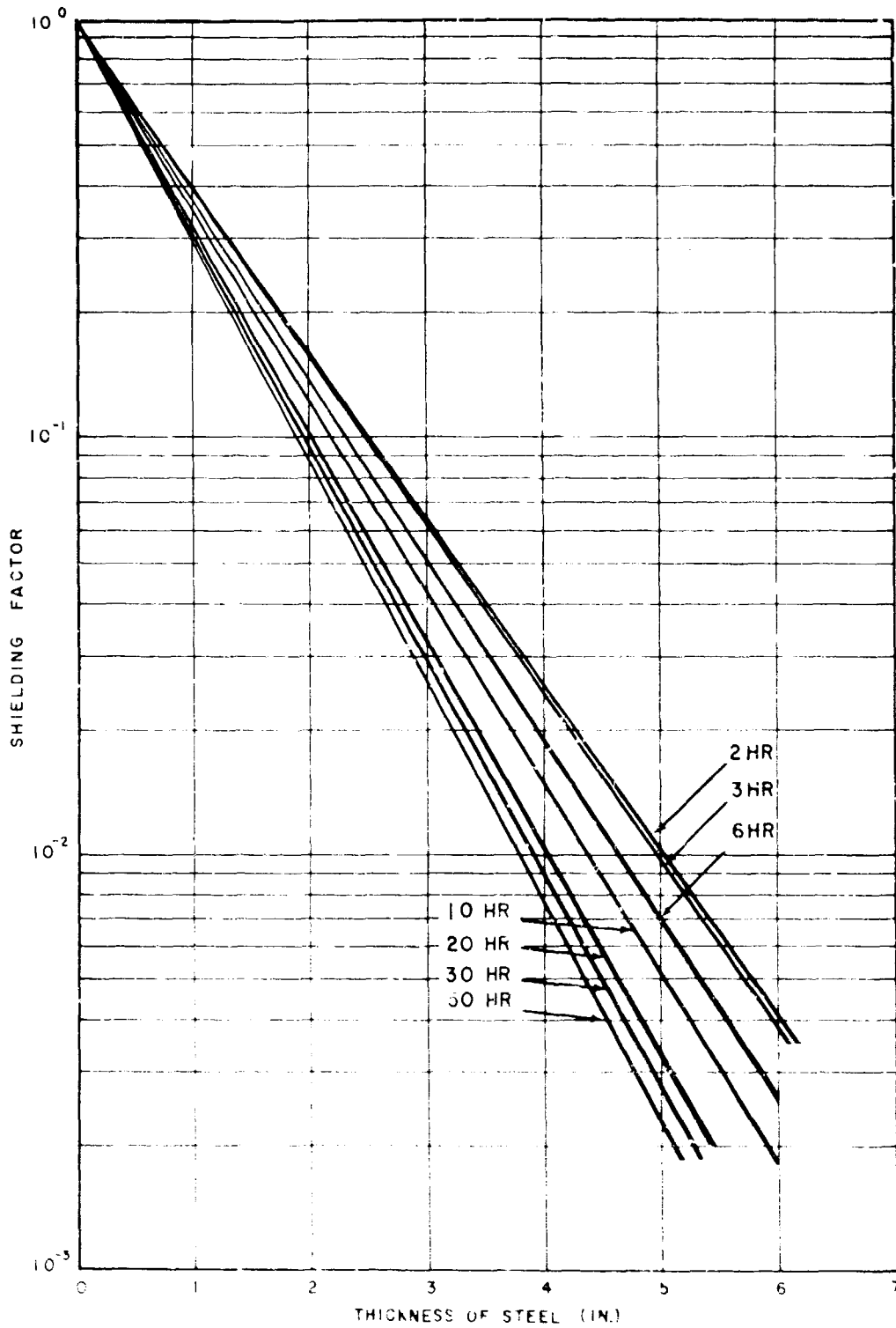

Figure 3.33 Absorption curves for different times based on average values of  $\bar{\mu}$ .

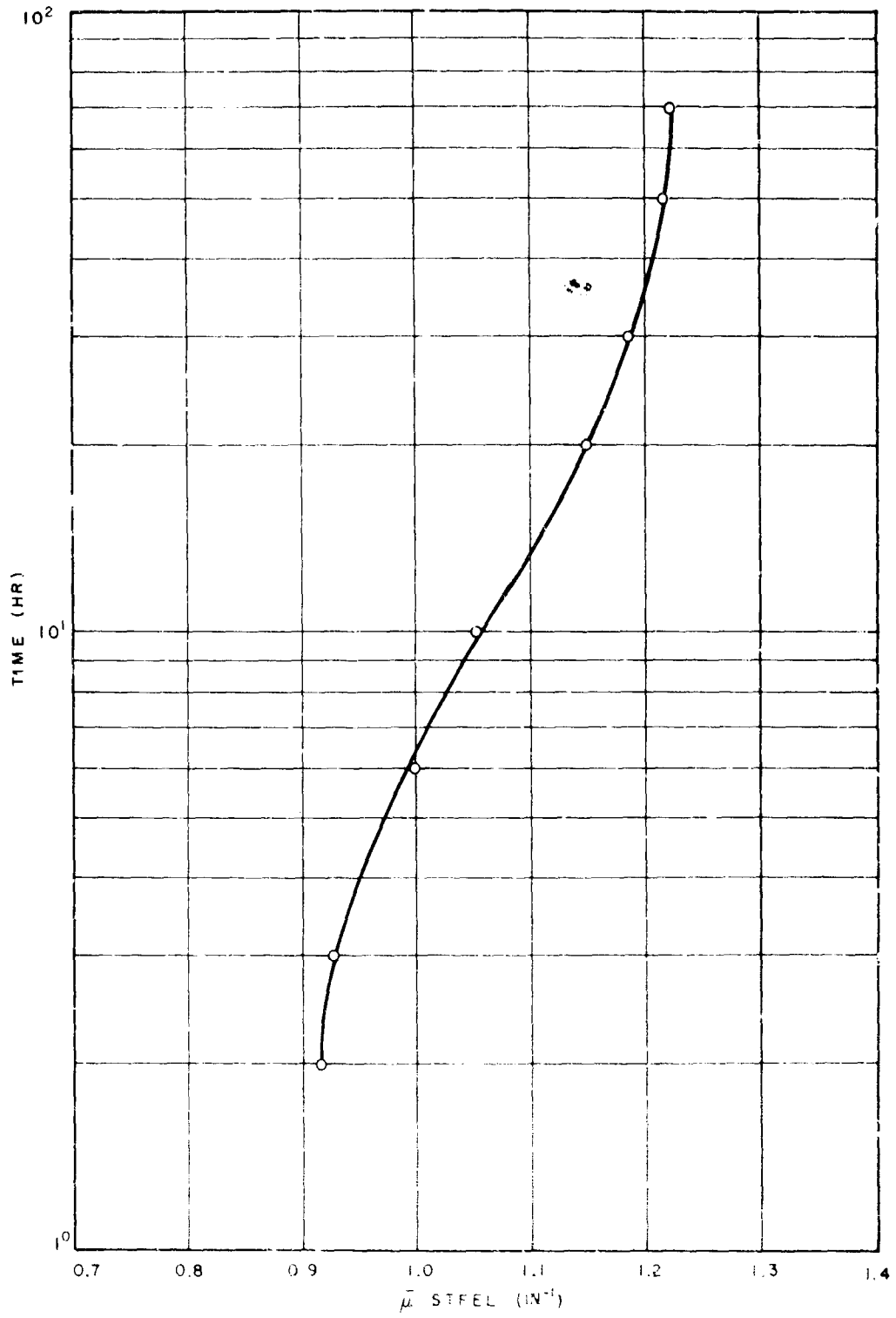

Figure 3.34  $\bar{\mu}$  as a function of time.

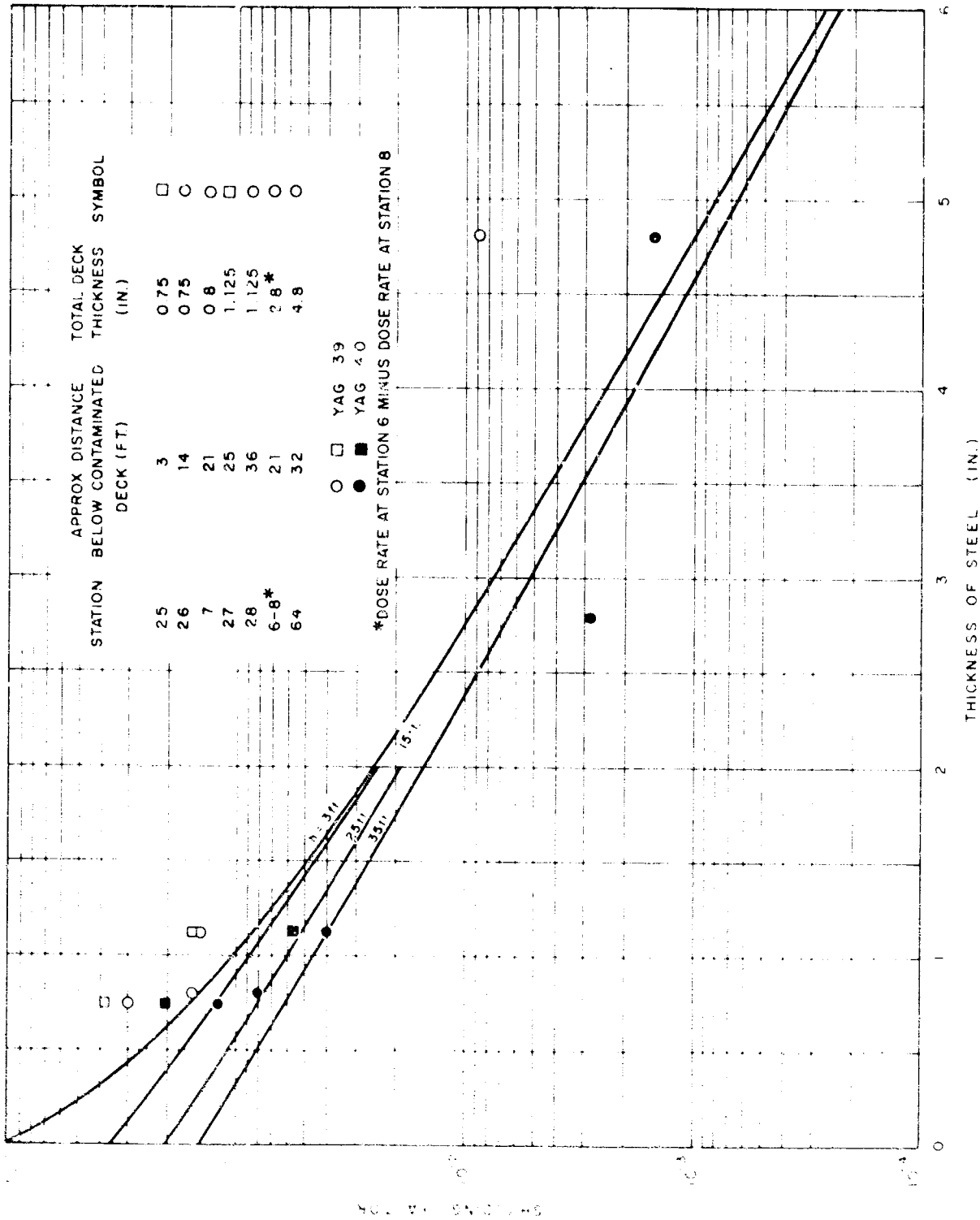

Figure 3.35 Shielding factors as a function of deck thickness at 2 hr ( $\bar{\mu} = 0.917 \text{ in.}^{-1}$ ).

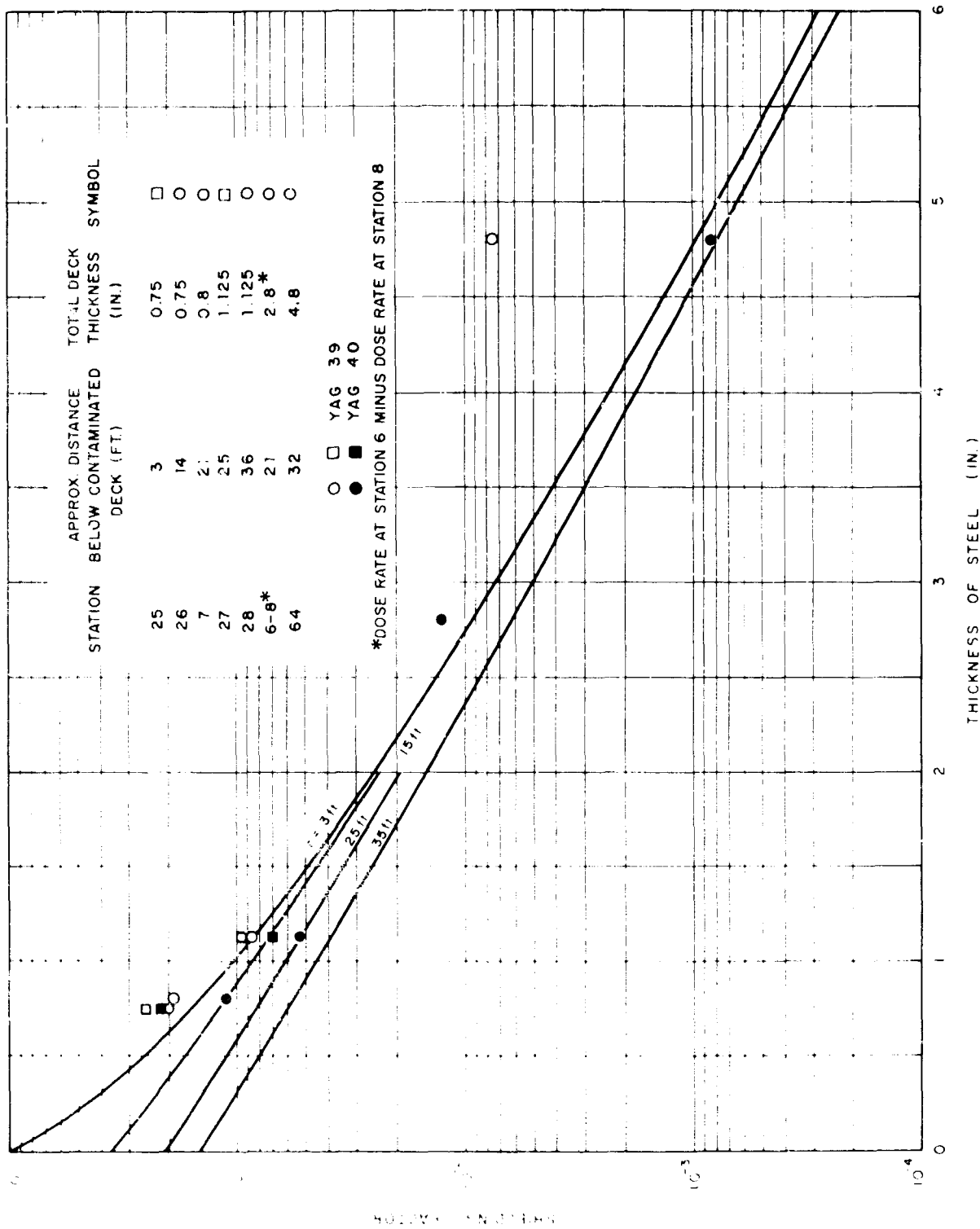

Figure 3.35 Shielding factors as a function of deck thickness at 3 hr ( $\bar{\mu} = 0.928 \text{ in.}^{-1}$ ).

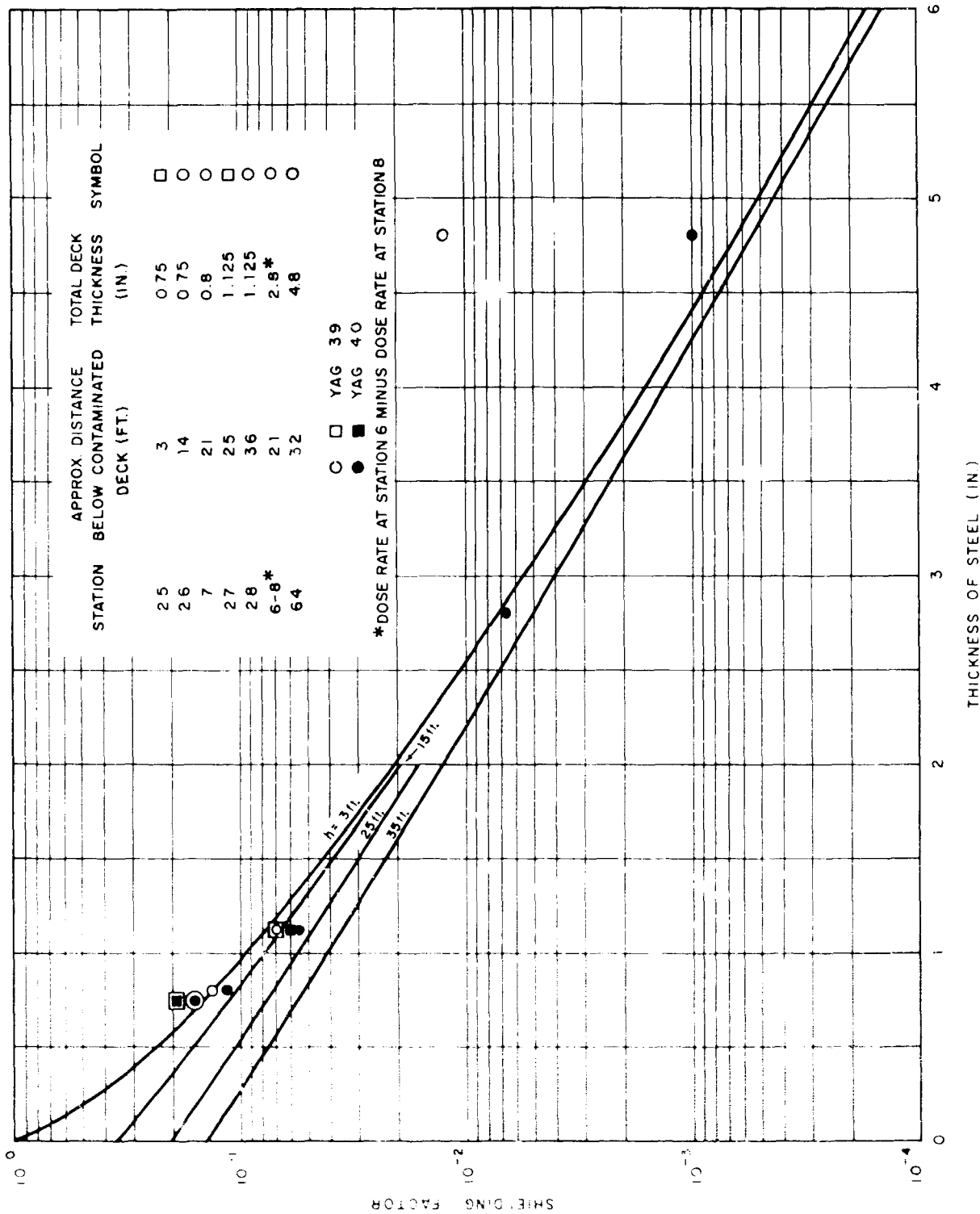

Figure 3.37 Shielding factors as a function of deck thickness at 6 hr ( $\bar{\mu} = 0.998 \text{ in.}^{-1}$ ).



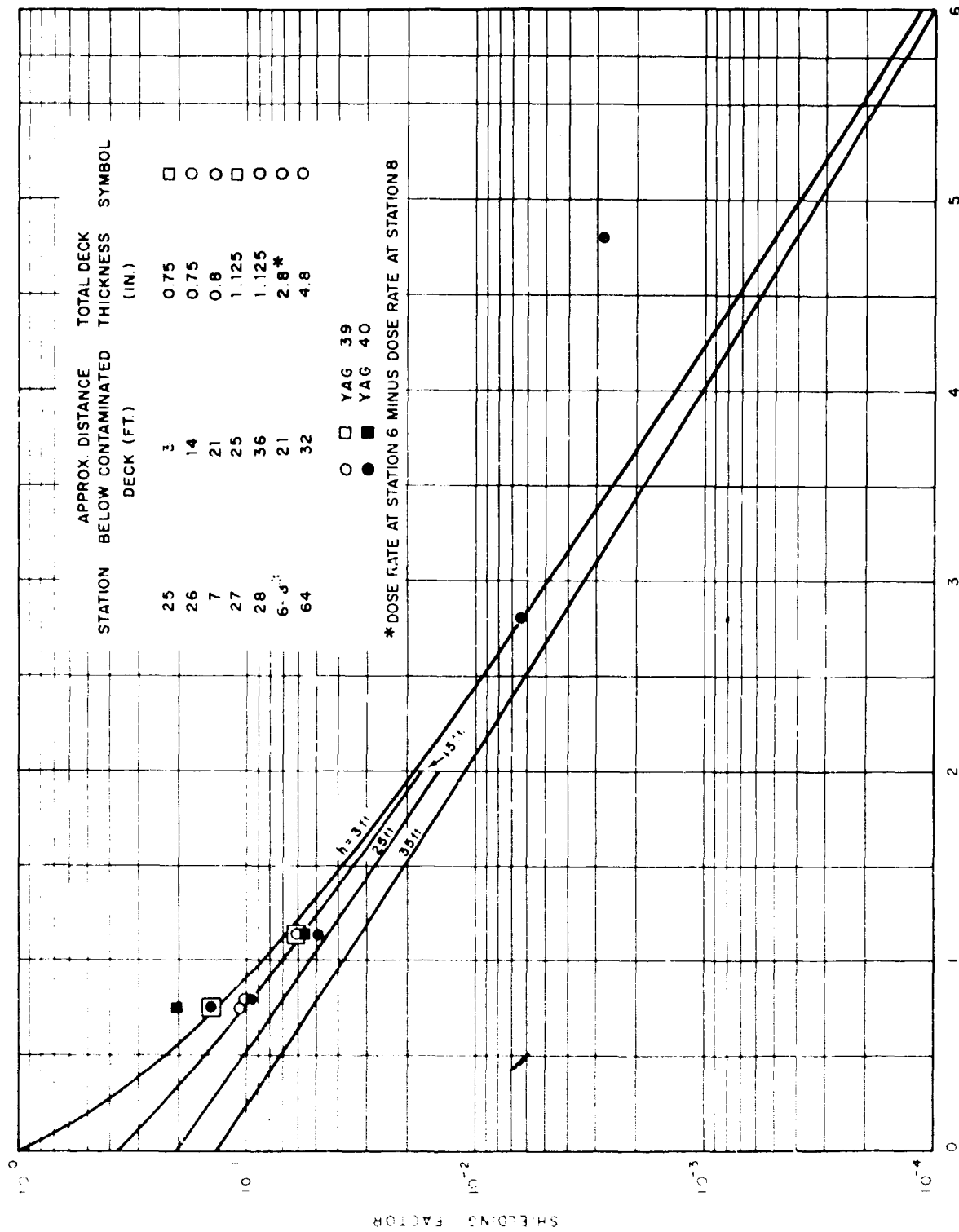

Figure 3.38 Shielding factors as a function of deck thickness at 10 hr ( $\bar{\mu} = 1.05 \text{ in.}^{-1}$ ).

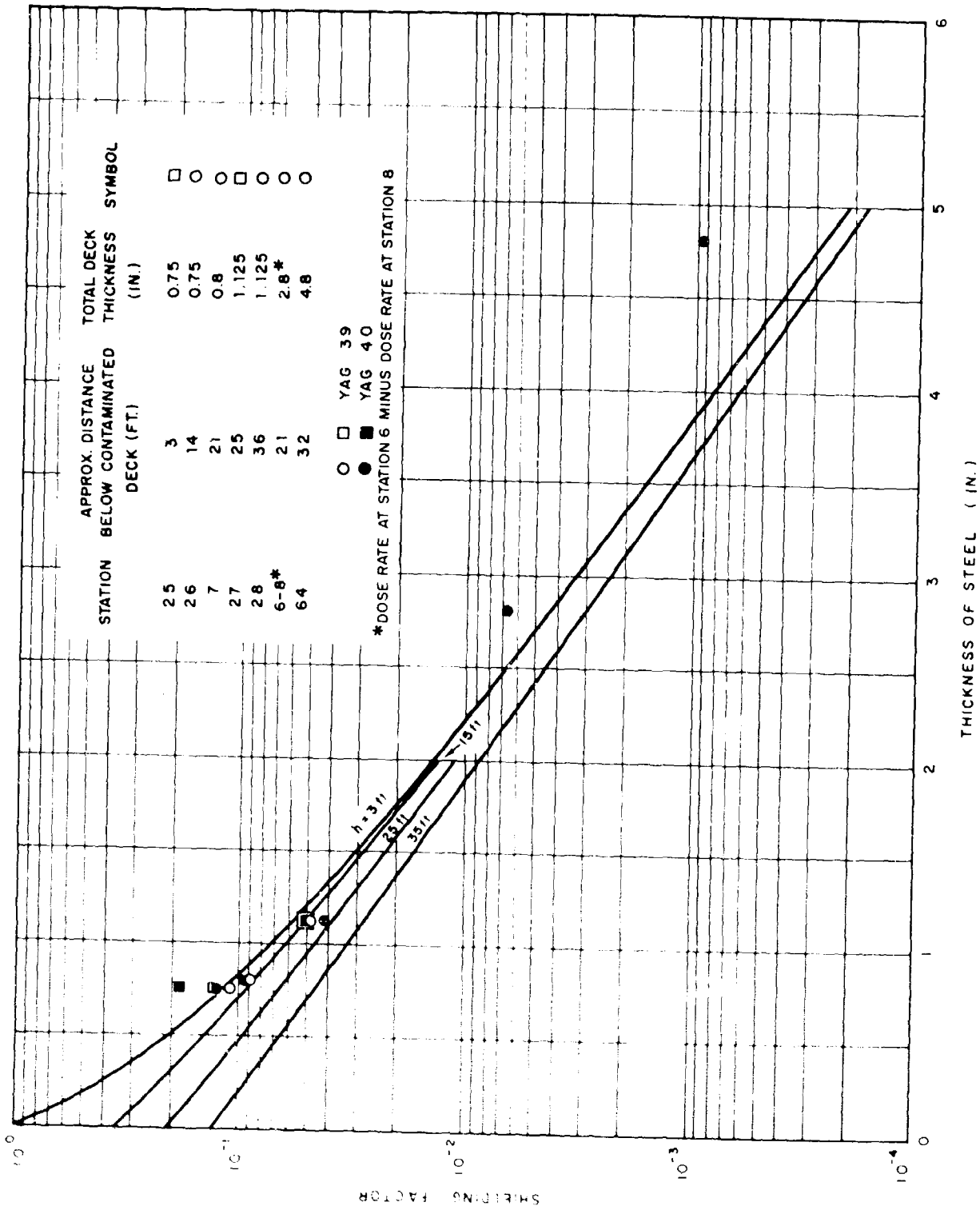

Figure 3.39 Shielding factors as a function of deck thickness at 20 hr ( $\bar{\mu} = 1.15 \text{ in.}^{-1}$ ).

It was concluded in Appendix B that the overall shielding factors for YAG 40, with the exception of the recorder room station, should be only slightly greater than the shielding factors for deposited material alone. Comparison of the computed curves and observed values on YAG 40 for the lightly shielded stations does, in fact, indicate a close agreement. There are considerable discrepancies at certain times between the observed values under the 2-in. plate and the computed values; however, the observed values are sensitive to small instrument errors, because of the correction described above (which involves relatively small differences).

Generally, the observed values in the recorder room are greater than the computed values and decrease less rapidly with time. This discrepancy might be caused, in part, by the lack of exact equivalence between concrete and an equal mass of steel. Greater attenuation should occur for a steel plate, because of the greater photoelectric absorption by steel of the low energy gamma rays; this effect should become more pronounced with increasing time, because of the apparent overall softening of the radiation energy spectrum. It is also probable that the increased importance of activity in the sea water at this location causes part of the discrepancy. This possibility is indicated in Appendix B, where it is pointed out that the shielding factor from deposited activity at this location may be considerably less than the observed overall shielding factor. One further fact should be pointed out: where the attenuation is large, the value of the shielding factor is quite sensitive to the value of the absorption coefficient  $\bar{\mu}$ . For example, where the attenuation is sufficient to give a shielding factor in the neighborhood of 0.001, a change of only 15 percent in  $\bar{\mu}$  will change the computed shielding effectiveness by a factor of 2.

Observed and computed shielding factors as a function of time for Stations 25, 26, 27, and 28 on YAG 40 are compared in Figures 3.40 through 3.43. The decrease with increasing time in the computed values and in the observed values at later times can be attributed to a decrease in the effective radiation energy with time. The more-rapid decrease in some of the observed values at early times, particularly evident for the Shot 2 data, may be caused by a change with time in the relative contributions from airborne and deposited activity to the total radiation field. This possibility is consistent with calculations indicating less attenuation from activity in the air surrounding the ship than for deposited activity because of the different geometry of the sources.

### 3.5 CONCLUSIONS

1. Determination of the shielding effectiveness of ships' structures from the data of this study is complicated by the fact that the measured dose rate at any location may be due to radioactivity deposited on both horizontal and vertical weather surfaces, to activity in the air during fallout, and to activity in sea water. The overall shielding effectiveness at any location depends on the magnitude of each of these various sources of radiation and on the shielding provided by the ship's structure for each of these sources.

2. The overall shielding factor, defined as the ratio of the dose rate in a compartment to the dose rate measured at an unshielded location

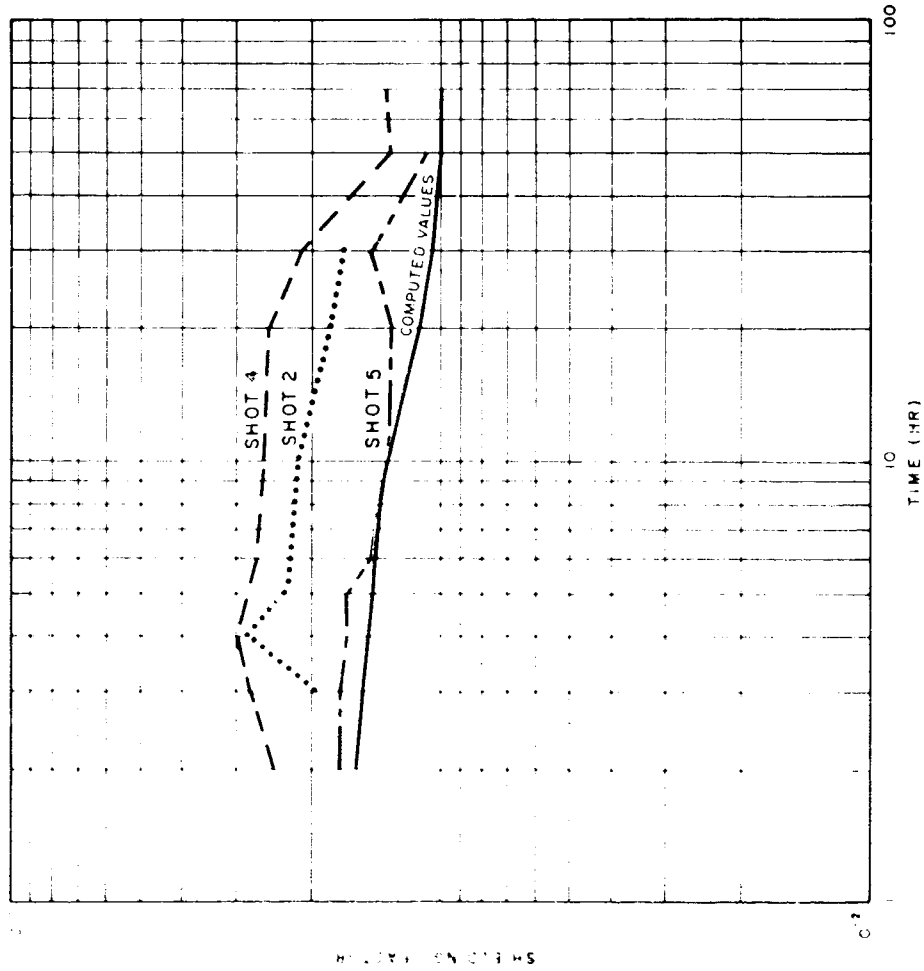

Figure 3.40 Comparison of computed and observed shielding factors, YAG 40, Station 25.

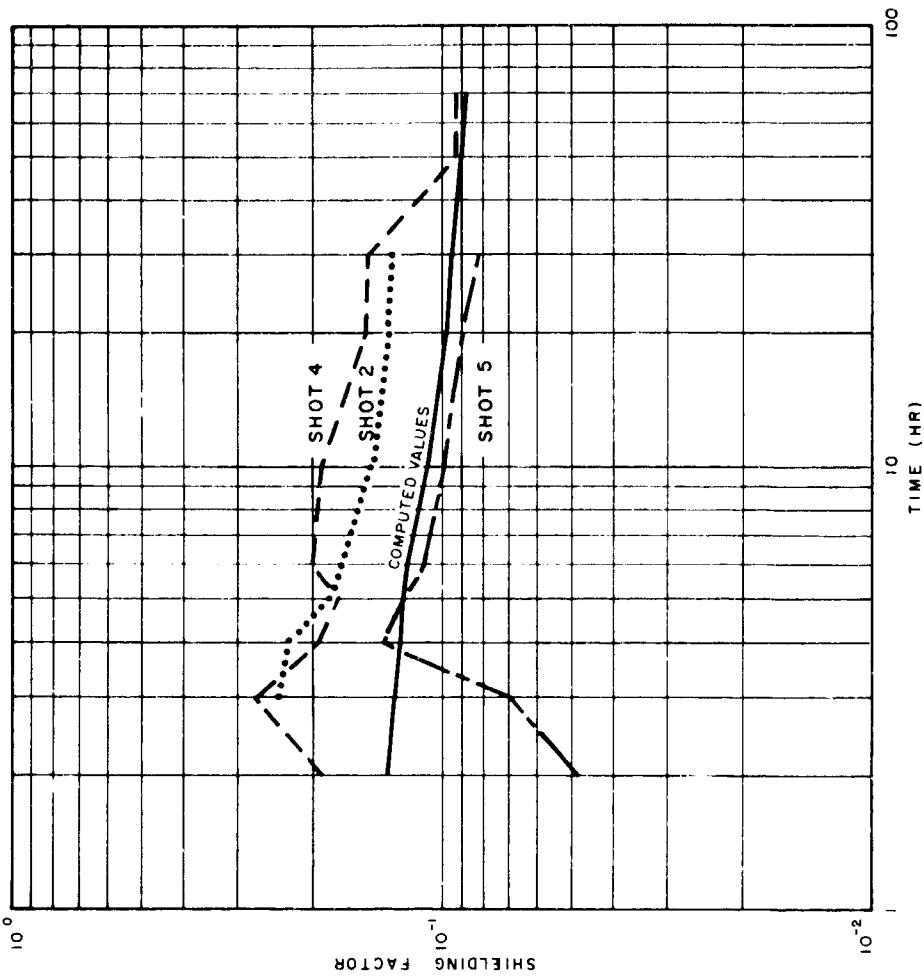

Figure 3.41 Comparison of computed and observed shielding factors, YAG 40, Station 26.

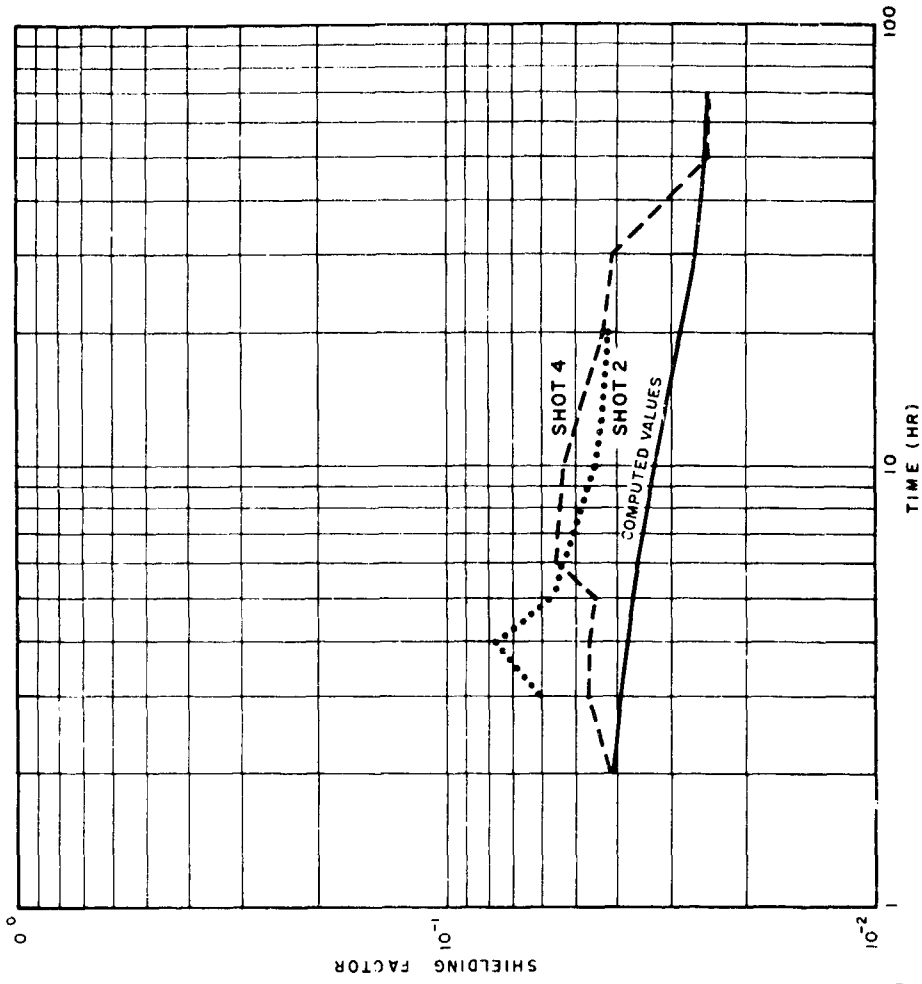

Figure 3.43 Comparison of computed and observed shielding factors, YAG 40, Station 28.

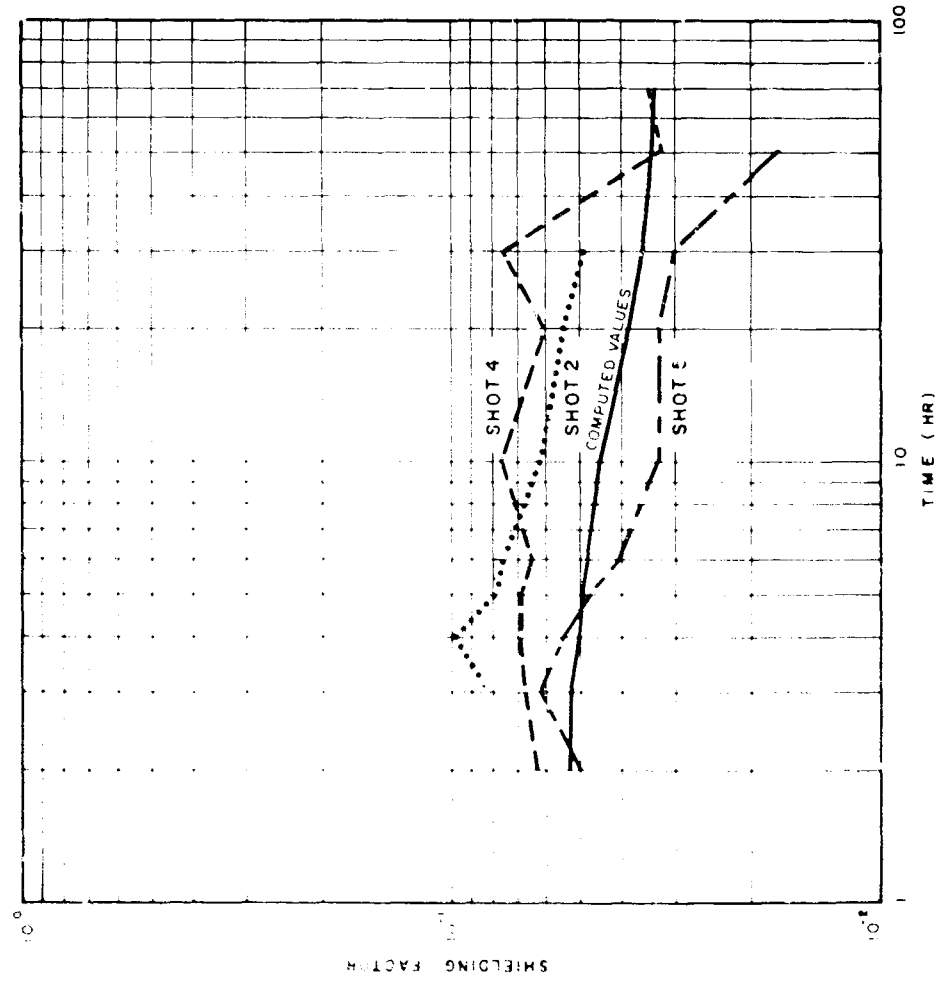

Figure 3.42 Comparison of computed and observed shielding factors, YAG 40, Station 27.

above the weather deck, was found as a function of time for various locations. The following general conclusions can be made: (a) the shielding factor decreased with increasing time, an observation which may be attributed to a decrease in the effective gamma radiation energy with increasing time; (b) for below-deck compartments, the shielding factor decreased with increasing thickness of steel and with increasing distance between the detector and the upper deck; (c) in below-deck compartments the overall shielding factor was greater on YAG 39 than on YAG 40. This difference can be attributed to the large reduction in activity on the YAG 39 weather decks effected by the washdown system, which does not, however, appreciably influence other radiation sources.

3. Data from superstructure compartments were not so consistent as from below-deck spaces, probably because of the more-complicated geometry and relatively light construction of the superstructure. Overall shielding factors in superstructure locations, however, did tend to decrease with increasing distance of the location from the top of the house and also decreased with increasing time.

4. Shielding factors at locations between the second deck and the upper deck were in the range from 0.1 to 0.2 on YAG 40 and from 0.15 to 0.30 on YAG 39. In the hold, the values ranged from 0.03 to 0.05 on YAG 40 and from 0.06 to 0.10 on YAG 39. In superstructure compartments on both ships, the values generally were in the range from 0.1 to 0.6.

5. Dose-rate data within the steel pipes mounted on the upper deck provided a series of absorption curves at various times for each shot and for each ship. These curves indicated an approximately exponential attenuation of the radiations by a steel absorber. It was possible to evaluate apparent absorption coefficients which were found to increase regularly with increasing time. This apparent absorption coefficient included the build-up effect of radiations reaching the detector after being scattered within the pipe walls.

6. Overall shielding factors on YAG 40 are believed to provide a good approximation to the shielding factors for activity deposited on the deck surfaces. Calculations of shielding factors for deposited activity, using the absorption data from the pipe studies, were found to agree well with observed values on YAG 40. The greatest discrepancy was found for the most highly shielded location in the instrument recorder room. At such locations, however, it is not practical to compute a precise value. The shielding factor for this location is quite sensitive, both to the thickness of steel traversed by the radiations and to the value of the apparent absorption coefficient. For example, a 15 percent change either in the assumed thickness of steel between the detector and the deck or in the value of the apparent absorption coefficient will alter the shielding effectiveness by a factor of 2. Another uncertainty about locations well-shielded from radioactive sources on the weather deck is the contribution from other sources, particularly waterborne activity or activity which adheres to the ship's hull.

### 3.6 RECOMMENDATIONS

Further analysis of the data from this project and from other fallout measurement projects may make possible the determination of the shielding effectiveness for radiations from airborne and waterborne activity. These

results should be compared with calculations. In future tests, instrumentation should be provided to better separate the radiations from the various sources.

Further analysis of the data should be made to provide shielding factors for times greater than those covered in this report. This information would be of value in determining the shielding effectiveness with respect to integrated dosage.

The discrepancy between shielding values obtained by various measuring devices should be further investigated.

The shielding factor for well-shielded locations cannot be predicted precisely, because small changes in such parameters as deck thickness and absorption coefficients cause large changes in the shielding factor. Deck thicknesses are not constant, and absorption characteristics of the radiations for any particular situation cannot be exactly predicted. However, further study of the reliability of predicted shielding factors at well-shielded locations should be made.

## Chapter 4

# SHIP DECONTAMINATION

F. S. Vine

During the period 1 February to 25 May 1954, two test ships, YAG 39 and YAG 40, were exposed to fallout from nuclear detonations during Operation Castle and received radioactive contamination on three occasions. After Shot 2, only the YAG 40 required decontamination; the YAG 39, a washdown-fitted ship, apparently received a negligible amount of contaminant. Neither ship needed decontamination after Shot 4; both were decontaminated following Shot 5.

The decontamination procedures were placed in two categories: "experimental" and "operational." There were five experimental procedures consisting of various combinations of firehosing, hot-liquid-jet cleaning, and scrubbing with deck brushes. The operational procedures---which included the use of removable protective coatings, paint removal with chemical stripper, resurfacing of wood decks and washing with a high pressure, large-volume hot-liquid jet---were employed primarily to reduce the radiation levels sufficiently to permit continued ship operations within Task Force exposure limits for personnel.

In the decontamination of the YAG 40 after Shot 2, the experimental procedures, exclusive of the effect of decay, removed an average of 59 percent of the detectable contaminant, as determined by beta measurement, and nondestructive operational methods, as a followup, removed 38 percent of the remainder, or a total reduction of 76 percent. Where operational methods, including chemical stripping, were employed in nonexperimental work on both ships after Shot 5, the overall effectiveness did not vary materially from the combined effect of experimental and operational procedures. A total reduction of 80-90 percent in the average gamma dose rate was obtained in all instances, as the combined result of decontamination and the natural decay during the extended time required for decontamination.

It is concluded that a washdown system is the most-effective tactical decontamination countermeasure presently available and that, for ships not having washdown, a combination of firehosing and scrubbing with detergent is a satisfactory interim decontamination procedure for a tactical situation. Protective coatings must be further developed and improved to meet the requirements of a tactical procedure.

Recommendations are made that combat and support vessels be fitted with some form of washdown system and that, as an alternate or supporting procedure, materials and equipment for firehosing and scrubbing be supplied to ships and that their personnel be properly trained in ship decontamination with these methods.



#### 4.1 BACKGROUND

Subsequent to the Bikini-Baker tests, attempts were made to effect gross decontamination of certain test ships. The results of these efforts were inconclusive. Later and continuing laboratory, engineering-scale and land-based field-operation tests produced decontamination methods and techniques of varying complexity and potential effectiveness.

A number of these were discarded, at least temporarily, as unsatisfactory for reasons of inapplicability to large-scale operations, ineffectiveness relative to the effort and equipment required, disposal of contaminated waste, inherent industrial hazards and fire and explosion dangers. Two categories of methods were ultimately established: non-destructive and destructive. The nondestructive methods consisted of firehosing, hot-liquid-jet cleaning, and scrubbing with soap or detergent additives. The destructive, or surface-removal, methods involved the use of cutting or abrasive tools and machinery, chemical reagents, chemical strippers and flame cleaners, all of which were potentially dangerous, relatively slow, and often undesirable because of their detrimental effect on the decontaminated surfaces. They were, therefore, considered to be limited to use in so-called industrial decontamination operations.

With the continued growth in importance of nuclear weapons in considerations of naval warfare, it became apparent that means had to be devised for the radiological protection of combat and support vessels which might become radioactively contaminated during the execution of a tactical mission. This requirement resulted in the development of the washdown system. The problem of ships not fitted with this device still remained. Furthermore, the actual extent of either the protection or the decontamination afforded by the washdown system was unknown, since only limited testing with nonradioactive simulants had been accomplished and a need for additional decontamination could reasonably be expected.

It was evident, therefore, that test ships should be subjected to the fallout from a nuclear weapon in order that the applicable recovery procedures could be evaluated and effective countermeasures ultimately provided for naval ships.

#### 4.2 OBJECTIVES

The general purposes of Project 6.4 during Operation Castle was to field test procedures and countermeasures for ships subjected to radioactive fallout from a nuclear detonation. Specific objectives were to: (1) evaluate various combinations of firehosing, hot liquid jet cleaning and scrubbing (with detergent) with regard to removal of contaminant, manpower effort and the equipment and materials required; (2) recommend, on the basis of the above information, an interim countermeasure for the tactical recovery of ships contaminated by the fallout from a nuclear detonation; (3) investigate, on a suitable scale, the characteristics of removable coatings for protecting ships' weather surfaces from radioactivity and for facilitating subsequent decontamination; and (4) reduce, as necessary, the total radiation levels of the two test ships to permit participation in subsequent shots without exposing operating personnel to radiation in excess of the limits permitted by the task force.

### 4.3 INSTRUMENTATION

The instruments required for the procurement of decontamination evaluation data were the AN/PDR-TIB gamma meter and the NRDL RBI-12 beta probe. These instruments and the procedures followed in procuring the test data are described in Chapter 9.

4.3.1 Decontamination Facilities. To facilitate decontamination operations, water and steam outlets were provided on the main deck of the YAG 39. Twelve locations were chosen, six forward of the superstructure and six aft, equally distributed to port and starboard. This arrangement made it possible to connect firehose and steam hose lines in close proximity to the areas being decontaminated. Each outlet provided 2 1/2-in. and 1 1/2-in. firehose and 2-in. and 1 1/4-in. steam connections. The firehose outlets were connected to the main washdown trunk and the steam outlets were connected to existing deck steam lines. Water for decontamination was supplied by one of the 1,000-gpm washdown pumps and steam was provided by the ships' boilers. At the outlets water pressure was maintained at 80 to 90 psig and steam pressure was 125 psig.

4.3.2 Decontamination Zones. Previous experience had shown that it was virtually impossible, because of the influence of residual radioactivity, to evaluate accurately the effectiveness of a decontamination method or procedure on a surface that had previously been contaminated and decontaminated; consequently, the experimental phase of the investigation was limited to the first successful contaminating event. To insure the independent evaluation of the various decontamination procedures, each ship was divided into six zones, each of which was subdivided into two sections, as shown in Figure 4.1.

4.3.3 Decontamination Equipment. All decontamination operations were accomplished with ship's allowance or available commercial equipment. A summary and brief description of equipment required for the various methods follows:

Firehose: 2 1/2-in. and 1 1/2-in. rubber lined firehose as procured from General Stores. Play pipes and Griswold 4 NAP fog nozzles were also standard stock items.

Hot-Liquid-Jet Cleaning: Two sizes of commercially available units<sup>1</sup> were used: 1250 gph type B unit and a 6000 gph unit. The large unit was designed by the manufacturer to be used with a Butterworth washing machine for cleaning an oil tanker's interior compartments. To adapt it for decontamination work, NRDL fabricated a portable turret nozzle. This unit consisted of a Grinnel anti-torque nozzle mounted on a Sellers fog generator frame. The original nozzle orifice was replaced with a standard 1 1/2-in. firehose play pipe. A "Chiksan" coupling permitted a 360-degree horizontal traverse. Interference by the mounting frame

---

<sup>1</sup>Mfg. by Sellers Injector Corporation, 1600 Hamilton St., Phila. 30, Pa.

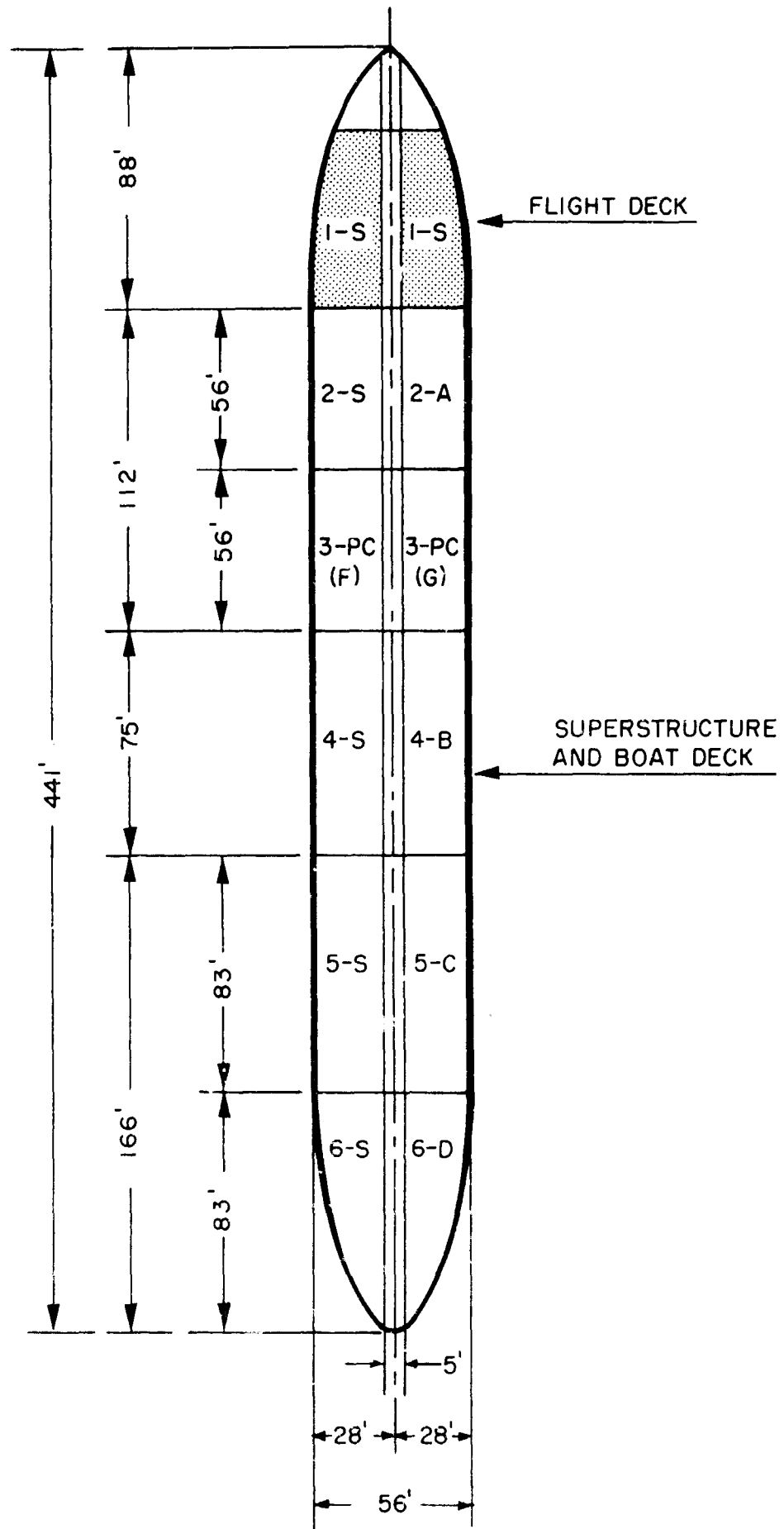

Figure 4.1 Decontamination zones of ship's weather deck.

limited the vertical angle to approximately 70 degrees. The entire assembly is shown in the photograph section of Appendix C.

Hand Scrubbing: Standard stock deck scrubbing brushes were used. The detergent used was Cleaning Compound C-120<sup>6</sup> which is compatible with salt water.

Surface Removal: The surface removal equipment included:

(a) Tennant machine<sup>3</sup> equipped with revo tool cutters or wire brush.

(b) Aurand air-driven revo tools.<sup>4</sup>

Paint Stripping: Hudson Peerless Sprayer,<sup>5</sup> Model 43030, 50-gal. capacity was used.

#### 4.4 OPERATIONS

The decontamination operations were controlled and directed from the ATF-106 during decontamination of the YAG 39 and from the YAG 39 during decontamination of YAG 40. In both cases, steam and water were supplied by YAG 39. Ship-to-ship communication was maintained by means of power megaphones. When close supervision was required, Project 6.4 personnel boarded the ship with the working teams. This practice was kept to a minimum to conserve the dosage of the limited number of project personnel available.

4.4.1 Decontamination Procedures, Shot 2. Five different decontamination procedures were evaluated on the YAG 40 after Shot 2. The procedures consisted of three basic methods: firehosing, hot-liquid-jet cleaning, and hand scrubbing with C-120 detergent<sup>6</sup> which is compatible with salt water.

Two or more of the methods comprised each of the procedures. The decontamination procedures were arranged in stepwise sequences as follows:

Procedures S (Standard): Step 1, Firehosing at 100 sq ft/min; Step 2, Hot-liquid-jet cleaning at 100 sq ft/min; Step 3, Hand scrubbing at 25 sq ft/min; and Step 4, Firehosing at 200 sq ft/min.

Procedure A: Step 1, Hot-liquid-jet cleaning at 100 sq ft/min; Step 2, Hand scrubbing at 25 sq ft/min; and Step 3, Firehosing at 100 sq ft/min.

Procedure B: Step 1, Hot-liquid-jet cleaning at 100 sq ft/min; Step 2, Hand scrubbing at 25 sq ft/min; and Step 3, Hot liquid jet cleaning at 100 sq ft/min.

Procedure C: Step 1, Firehosing at 100 sq ft/min; Step 2, Hand scrubbing at 25 sq ft/min; and Step 3, Firehosing at 200 sq ft/min.

Procedure D: Step 1, Hot liquid jet cleaning at 100 sq ft/min, and Step 2, Firehosing at 100 sq ft/min.

4.4.2 Sequence of Operations: Each zone except Zone 3, which was

---

<sup>2</sup>BuAer Item Stock No. R51C1569-100 (50-lb. container)

Stock No. R51C1569-125 (200 to 250-lb. container).

<sup>3</sup>Mfg. by G. H. Tennant Company, 2520 N. Second St., Minneapolis 11, Minn.

<sup>4</sup>Mfg. by Aurand Manufacturing and Equipment Company, 2643 Colerain Avenue, Cincinnati 25, Ohio.

<sup>5</sup>Mfg. by H.D. Hudson Manufacturing Company, 589 E. Illinois Street, Chicago, Illinois.

<sup>6</sup>Cleaning Compound, Specification C-120 (new specification, MIL-C-7907)

reserved for protective coating studies, was decontaminated in accordance with the assigned procedure.

A stepwise description of Procedure S is typical, since all other basic procedures were variations of it.

(a) Radiological survey (gamma and beta readings) taken (see Chapter 9).

(b) Surface firehosed with a 2 1/2-in. firehose at the rate of 100 sq ft/min, 90 psig average pressure. Area was firehosed from centerline of ship to rail, progressing from forward or aft to superstructure following sheer of ship.

(c) Radiological survey taken.

(d) Surface cleaned with a 1250-gal/hr hot liquid jet at rate of 100 sq ft/min; nozzle delivery at 125 psig and 180°F average temperature. Detergent C-120 was educted through the injector unit. This required a 20 percent solution (by weight) for a 1 percent concentration at the nozzle. Cleaning was from centerline to rail and followed the sheer as with firehosing.

(e) Surface hand scrubbed at rate of 25 sq ft/min with deck brushes.

(f) Surface firehosed with 2 1/2-in. firehose at the rate of 200 sq ft/min, 90 psig average pressure. Forward progress same as Step 1.

(g) Radiological survey taken.

4.4.3 Decontamination Procedure, Zone 3. Zone 3 was coated with the radiological protective coating, Mare Island Formula 980. This zone was decontaminated using the procedure developed for removal of the protective coating in preliminary tests on the YAG 39 (See Appendix C). The procedure consisted of the following steps:

(a) The surface was sprayed with a 2-percent solution of caustic soda (commercial grade NaOH).

(b) After allowing caustic to react for 5 to 15 min, surface was flushed with a 1 1/2-in. firehose at a rate of 20 sq ft/min, 90 psig average pressure.

(c) Surface cleaned with 1250-gal/hr hot liquid jet at 20 sq ft/min; minimum temperature of 180°F.

4.4.4 Operational Decontamination Procedures, Shot 2. Upon completion of the tactical procedures, decontamination of the YAG 40 was continued on an operational basis. All weather surfaces except the top of the wheel house received the same treatment, which consisted of a thorough cleaning with the 6000-gal/hr hot liquid jet and NRDL turret nozzle at a rate of approximately 80 sq ft/min. The average delivery pressure and temperature were 160 psig and 185°F. A saturated solution of C-120 detergent was educted through the injector unit and comprised approximately 5 percent of the total delivery through the nozzle. When a convenient area had been cleaned in this manner, the 6000-gal/hr turret was used to wash the same surface and flush off the detergent with clear hot water, also at 80 sq ft/min.

The top of the wheel house was hand scrubbed using a 1-percent solution of C-120 detergent and was then flushed with a 1 1/2-in. firehose.

The wood boat deck, in a final operation, was resurfaced with a Tennant machine equipped with a wire brush tool. With the wire brush installed the machine could be operated at approximately 200 sq ft/hr.

The Tennant machine was modified for connection to a Roto-Clone dust collector but this accessory was dispensed with because of mechanical malfunctioning.

4.4.5 Operational Decontamination Procedures, Shot 5. After Shot 5 both the YAG 39 and YAG 40 were decontaminated with operational procedures.

With the exception of the flight deck, boat deck, and adjoining bulkheads and the top of the wheel house, the weather surfaces of the YAG 39 were cleaned with the 6000-gal/hr hot liquid jet, both alone and in conjunction with hand scrubbing. Additional passes were made in all areas except the flight deck and Zone 2.

The top of the wheel house, the superstructure bulkheads above the boat deck, and the boat deck itself were cleaned with the 1250-gal/hr hot liquid jet, scrubbed with C-120 detergent, and then firehosed. The yellow plastic enamel, with which the top of the wheel house was coated to facilitate aerial identification, did not respond to these decontamination methods, and the enamel was subsequently removed by repeated applications of caustic soda.

The flight deck of YAG 39 was coated with Mare Island Formula 980 protective coating as a means of facilitating any subsequent decontamination. It was removed as follows:

(a) Liberally applied caustic soda solution with deck swabs. No areas were permitted to dry prior to washing.

(b) Removed caustic and protective paint with the 6000-gal/hr turret.

All topside weather surfaces of the YAG 40 were painted with the experimental Formula 980 radiological protective coating prior to participation in Shot 5. This was a deviation from the test program as originally planned and was adopted as a prospective means of achieving greater operational decontamination effectiveness.

Prior to the actual removal of the protective coating, Zones 1, 2, 3, and 4 were washed down with a 2 1/2-in. firehose. This step was recommended by the Health Physics Group to remove loose contaminant which was being picked up to an undesirable extent on the clothing of sample recovery and survey personnel. After the firehosing, the protective coating was removed as follows:

(a) Applied caustic soda to vertical surfaces with pressure spray equipment and to horizontal surfaces (decks) with swabs.

(b) Removed as much of the protective coating as possible with 1 1/2-in. firehose after caustic soda solution had remained on surface from 10 to 15 min.

When the foregoing procedure failed to detach the protective coating from significantly large areas, particularly on vertical surfaces, and a gamma survey showed that the radiation level was not sufficiently reduced, the application of caustic soda solution was repeated, this time in a stronger concentration. Following this the surfaces were again washed down with the 1 1/2-in. firehose.

The top of the wheel house of the YAG 40, like that of the YAG 39, was painted with plastic enamel (red) for aerial identification. This enamel was removed with strong caustic soda solution.

The boat deck was resurfaced with the Tennant machine equipped with a revo-tool which permitted operation at a rate of 400 sq ft/hr. Approximately 1/8 in. of the wooden deck was removed.

Aurand air-driven hand tools were used to remove the deck surface at the boat davits and other obstructions around which the larger Tennant machine could not operate.

4.4.6 Radiological Surveys. Comprehensive data for the evaluation of the tested decontamination methods and procedures were obtained by detailed gamma and beta measurements at established monitoring stations. These surveys are described in detail in Chapter 9. A limited number of wipe samples were also taken to determine the extent and the removability of loose contaminant.

#### 4.5 RESULTS AND DISCUSSION

The necessity of conforming to ship movement schedules resulted in some curtailment of the data obtained from the decontamination studies. Complete tabulation of the test data is not included in this report because of its bulk. Information obtained by analysis and evaluation of the data is presented in a series of graphs. Decontamination procedures were evaluated on the basis of amount of contaminant removed from similar surfaces, manpower effort required, equipment and materials involved. Contaminant removal by the nondestructive experimental and operational methods was determined by beta surface measurements. The effectiveness of operational decontamination of the YAG 40 after Shot 5 by removal of Formula 980 protective coating and Navy Gray paint with a chemical stripper was established by the reduction in the gamma radiation field. In determining the decontamination effectiveness, all beta and gamma measurements were corrected for decay (Reference 6).

Uniform distribution of contaminant, a desirable factor in the evaluation and comparison of decontamination methods and procedures, was not obtained. As the result of the ship's course (YAG 40) and the relative wind direction during the contaminating event after Shot 2, contamination of the main deck on the port side exceeded that of the starboard side by factors of 2 to 3 in the decontamination zones. However, after decontamination, comparative plots (not included herein) of the test data on the basis of initial level versus percent of contaminant remaining for each procedure did not indicate that the percent residual levels were necessarily dependent upon or were influenced by the initial levels.

4.5.1 Experimental Decontamination, YAG 40, Shot 2. The average effectiveness and the required manpower effort for each of the nondestructive, experimental decontamination procedures are shown and compared in the bar graph, Fig. 4.2. In terms of percent of contaminant removed, the individual effectivenesses lie within the relatively narrow range of 50 to 72 percent, or a decontamination factor of 2 to 4. The possible range, as defined by 95-percent-confidence intervals, is 38 to 76 percent. On painted and steel, Procedure S was the most effective, removing 72 percent of the contaminant, but also required the greatest effort, 2.5 man-hr per 1000 sq ft of surface. Procedure D which required the minimum effort, 1.3 man-hr per 1000 sq ft was also the least effective, removing only 50 percent of the contaminant. Procedure A removed 54 percent but needed

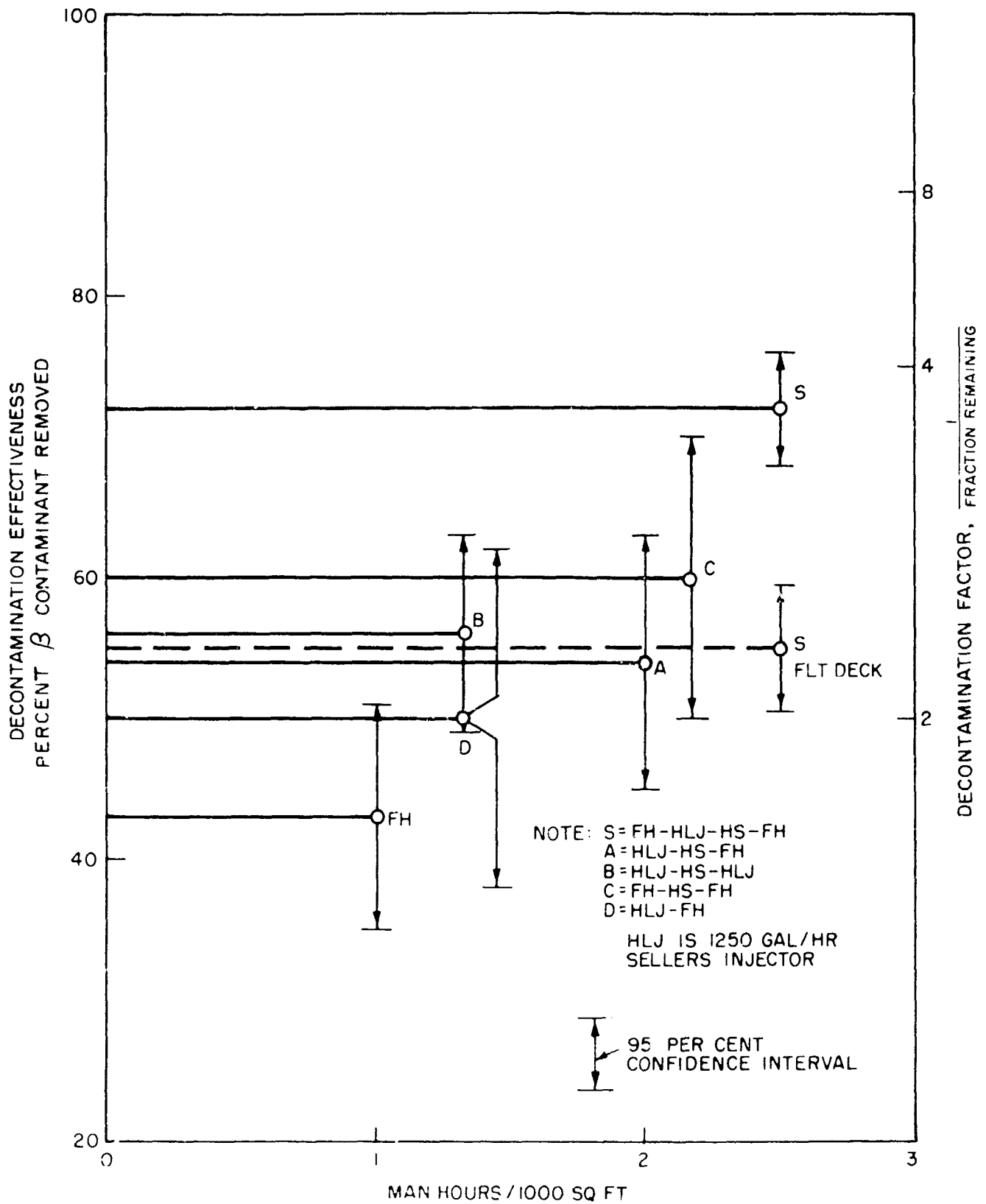

Figure 4.2 Evaluation of experimental decontamination procedures, YAG 40, Shot 2.



2.0 man-hr per 1000 sq ft. Procedure C removed 60 percent with 2.17 man-hr of effort per 1000 sq ft. The 95-percent-confidence interval of C overlaps those of S, A, and D. It is probable that S will consistently be more effective than C and the latter will be better than A and D.

Decontamination effectiveness is plotted in Figure 4.3 against the probable gamma dose received by decontamination personnel while cleaning a unit surface of 1000 sq ft. Dosage values are based on an initial level of 1 r/hr at start of a given procedure, and the effects of decay have been neglected. For every 1 r/hr increment of initial dose rate, Procedures A, C, and S will involve doses ranging from 1.46 to 1.60 r; firehosing and Procedures D and B will involve doses ranging from 0.78 to 0.95 r when decontaminating painted surfaces. It would appear that to remove amounts of contaminant significantly greater than 50 percent, the dosage to decontamination teams would jump 50 percent. Stained wood surfaces create an even more serious situation, since the most effective procedure, S, results in a dosage of 1.8 r for each r/hr of initial level, and only removes 55 percent of the contaminant.

Procedures S, A, and D included the use of a hot-liquid jet generated by special equipment, in this case a 1250-gal/hr Sellers unit. This item was omitted from Procedure C, which required only a 2 1/2-in. firehose and ordinary deck brushes, standard ships' allowance items. Procedure B has not been previously discussed for the reason that it was evaluated only on the wood boat deck. Although this deck was well coated with Navy Gray paint and, presumably, should have had the surface characteristics of similarly painted steel, this fact cannot be definitely established. However, considering the similarity of the methods comprising A and B, and the indicated effectivenesses of 54 and 56 percent, respectively, it is doubtful if B would have produced significantly better results on painted steel. Like D it required only 1.3 man-hr per 1000 sq ft, but again special equipment was involved.

The removal of 55 percent of the contaminant from the wood flight deck by means of Procedure S probably represents a greater effectiveness than would have been obtained by any of the other procedures on this surface. This deck had been given one coat of flight deck stain (No.21), much of which was absorbed by the wood, and the weather surface was relatively rough and difficult to decontaminate. It is probable that, had the other procedures been tested on this surface, they would have been less effective than S in about the same ratio evidenced on the painted steel deck.

The effectiveness of firehosing as a decontamination procedure was investigated on the wood flight deck and the painted steel main deck. It removed an average of 10 percent of the contaminant from the wood and 43 percent from the steel (Fig. 4.2). Although comparatively ineffective on wood, it was not without value on painted steel, particularly since the required effort was only 1.0 man-hr per 1000 sq ft and the upper limit of the confidence interval was 51 percent, or a decontamination factor of 2. This greater effectiveness could probably be achieved by closer control of the firehosing technique. Firehosing, therefore, would be a simple and useful method where a decontamination factor of 2 was sufficient or where limitations of time, manpower, or equipment rendered more-complex procedures impracticable.

A comparative summation of the five procedures tested shows that,

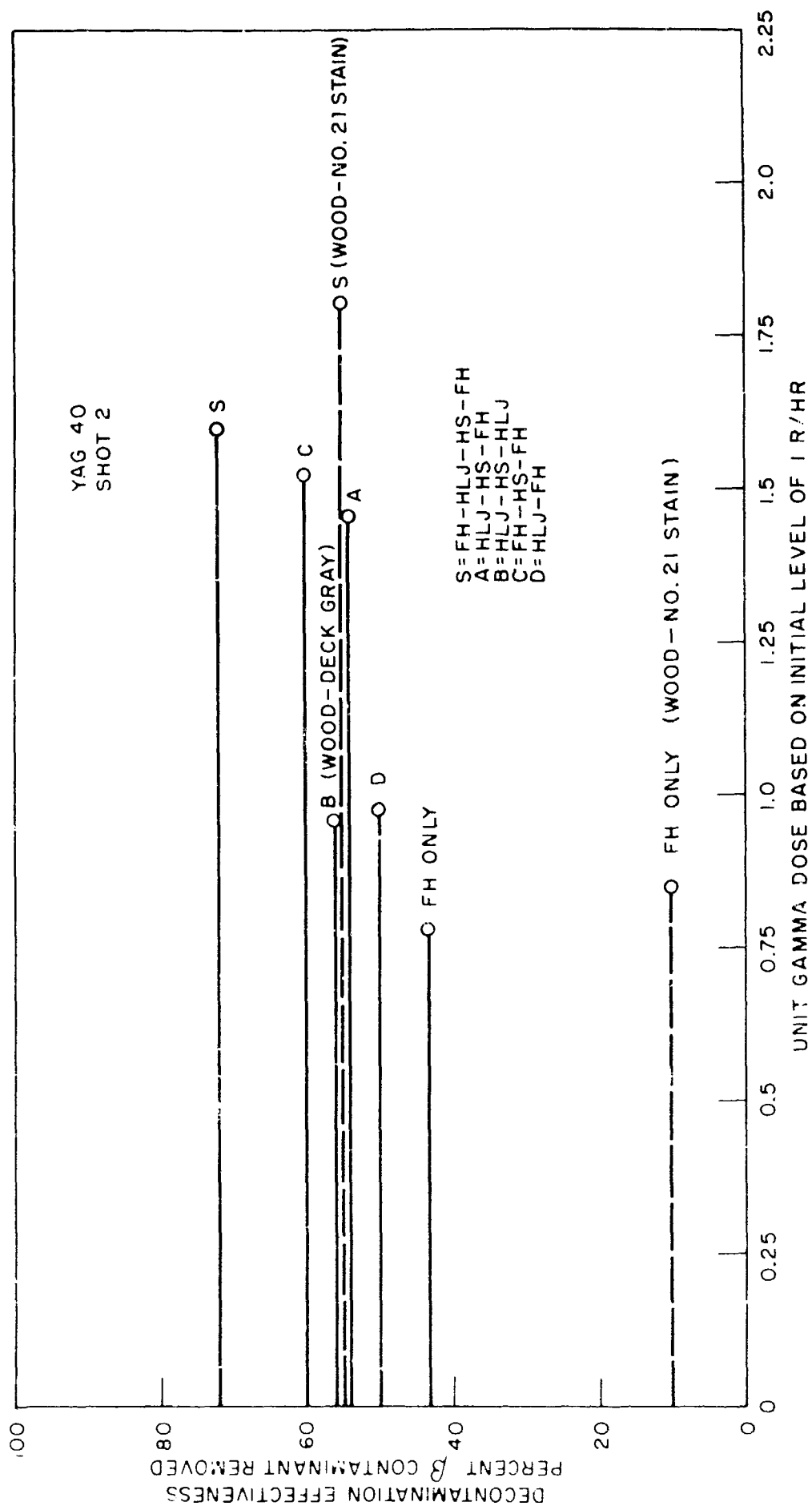

Figure 4.3 Gamma dose received by decontamination team for initial level of 1 r/hr, neglecting effects of decay.

from the standpoint of effectiveness, manpower effort and the equipment required, Procedure C, consisting of firehosing, hand scrubbing (with detergent) and firehosing is the optimum and can be recommended as an interim decontamination procedure for Navy ships.

Since only a limited study of protective coatings had been made at the laboratory, their evaluation after Shot 2 was conducted separately. The results are discussed in Appendix C.

4.5.2 Operational Decontamination, YAG 40, Shot 2. On completion of the experimental studies, further decontamination of the ship was undertaken in an effort to reduce the radiation field to a level considered permissible by the task force for exposure of personnel during subsequent operations. This "operational" decontamination was not primarily an experimental study and the use of a turret nozzle (1 1/2-in firehose play pipe) in conjunction with a 6000-gal/hr Sellers injector was adopted as a nondestructive procedure which would possibly provide a high degree of decontamination effectiveness with a minimum expenditure of time and effort. The last two objectives were not realized, since a second pass was made to flush off the detergent with clear hot water. The use of a 1 1/2-in. firehose for final flushing in this type of operation should be investigated.

On painted steel a further contaminant removal, varying from 10 to 22 percent, was accomplished with an additional effort of 2.5 man-hr per 1000 sq ft, as shown in Figure 4.4. In general, the effectiveness of the operational decontamination was correspondingly greater in those areas where the previously tried experimental procedures had removed relatively lesser amounts of contaminant, e.g., after S, which removed 72 percent, a further reduction of only 10 percent was obtained, whereas after D, the least effective experimental procedure, an additional 22 percent of the contaminant was removed. This relationship was logically to be expected.

Operational decontamination was least effective on the wood flight and boat decks, accomplishing an additional removal of 9 percent from the former and 4 percent from the latter. This does not necessarily indicate that the previous decontamination had been exceptionally effective. It is quite probable that the poor results were occasioned by inability to dislodge detectable contaminant from cracks, payed seams, and other surface irregularities.

If it can be assumed that a major part of the loosely held contaminant had been eliminated by the experimental procedures and that only the tenacious material remained, then the turret nozzle and 6000-gal/hr injector constitute a decontamination procedure of high potential effectiveness and efficiency. Further tests of this equipment should be conducted to improve the equipment and technique and to reduce the manpower effort required.

The failure to remove more than 60 percent of the contaminant from the boat deck was reflected by the level of gamma radiation in certain of the living quarters within the ship's superstructure. Since it was apparent that the nondestructive procedures were inadequate, the boat deck was resurfaced. In this operation, the surface paint and from 1/16 to 1/8 in. of wood were removed by a Tennant machine equipped with a wire brush.

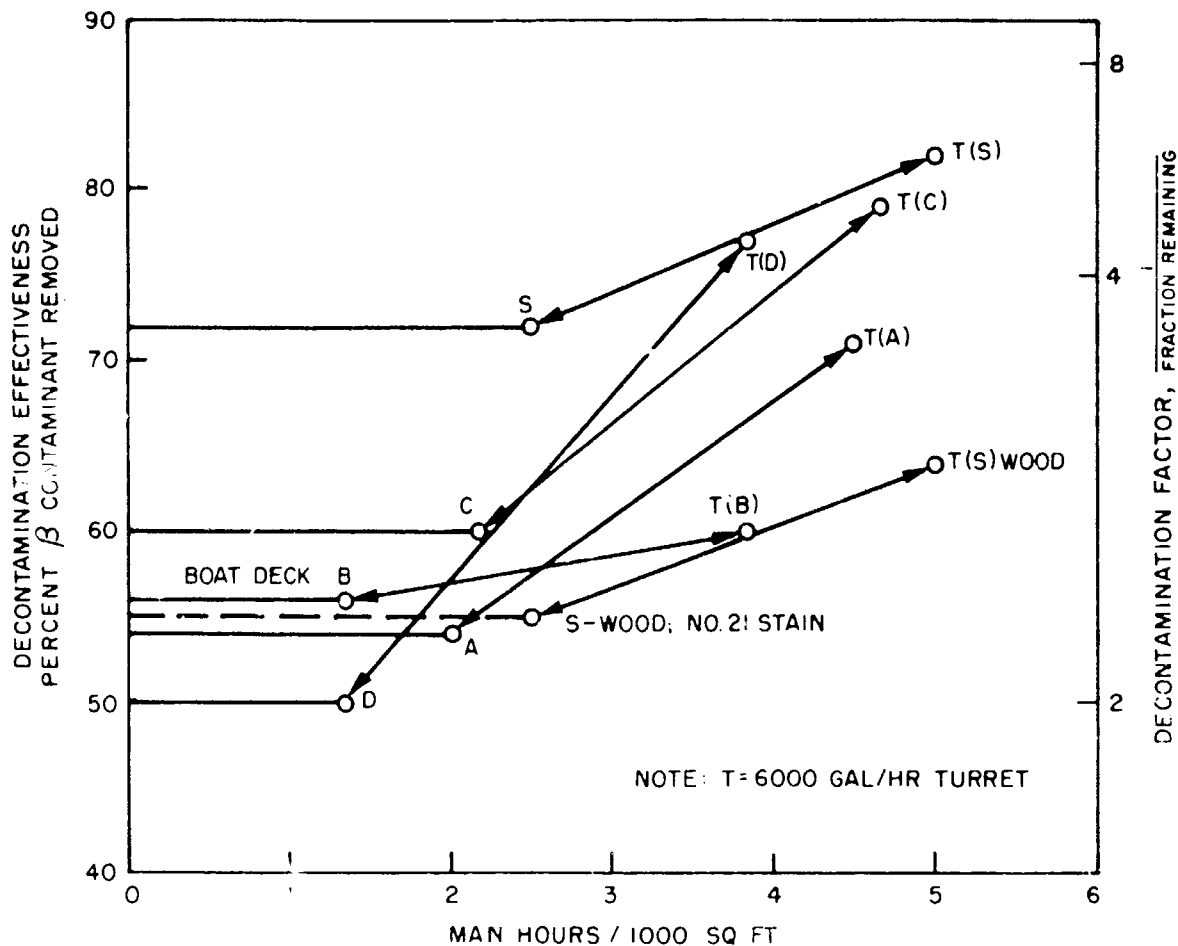

Figure 4.4 Evaluation of decontamination procedures, YAG 40, Shot 2.

Resurfacing removed an additional 30 percent of the contaminant, as shown in Figure 4.5. The corresponding gamma field was thereby reduced to an acceptable level.

Definite limitations to this type of procedure were evidenced. With the wire brush installed in the machine, 20 man-hr of effort were required for each 1000 sq ft of surface covered. This did not include additional personnel needed to collect and dispose of the contaminated waste. The machine was heavy and cumbersome and would have been difficult to control had the ship been in motion. Surfaces adjacent to bulkheads, boat cradles, and davits could not be reached. Repainting of the deck as a protective measure was necessary. The Tennant machine, therefore, is not applicable to tactical decontamination.

4.5.3 Operational Decontamination, YAG 39, Shot 5. The radiological situation aboard the YAG 39 after Shot 5 was similar to that of the YAG 40 after Shot 2 upon completion of the experimental decontamination in that much of the loosely held contaminant had been removed by the washdown system and only the more-tenacious material remained. This explains the fact that only 18 to 50 percent of the contaminant was removed by the first pass, as indicated in Figure 4.6. Actually, the gamma radiation level was relatively low; but since it was planned to use this ship as

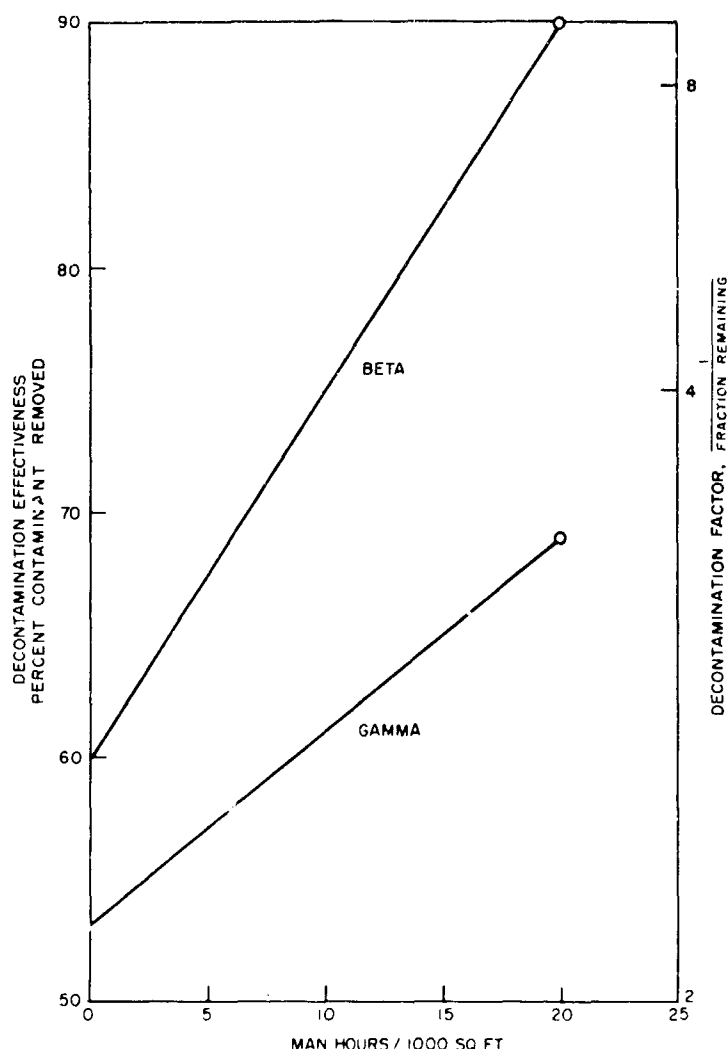

Figure 4.5 Evaluation of Tennant machine resurfacing of wood boat deck, YAG 40.

an operating base for the decontamination of the YAG 40, a further reduction was attempted.

To conserve time, all available methods, i.e., firehosing, hand scrubbing, the 1250-gal/hr hot liquid jet and the 6000-gal/hr turret nozzle were then utilized as a matter of expediency and without particular regard to their individual merit. The extent of the additional decontamination is also shown in Figure 4.6. With the exception of Zone 2, which was not given a second pass, from 59 to 68 percent of the residual contaminant was successfully removed.

The wood flight deck had been sprayed with the Formula 980 protective coating, and the stripping of this paint with a caustic soda solution and the 6000-gal/hr turret nozzle removed 79 percent of the contaminant.

The gamma radiation level within the superstructure living quarters was such that resurfacing of the boat deck was not necessary.

4.5.4 Appraisal of Nondestructive Decontamination Methods and Procedures. The effectiveness of the nondestructive decontamination methods and procedures, as determined by this field operation, agree closely with the results of previous laboratory, engineering-scale, and field tests. It is indicated that the maximum potential has been reached and that, for these procedures, the decontamination effectiveness lies

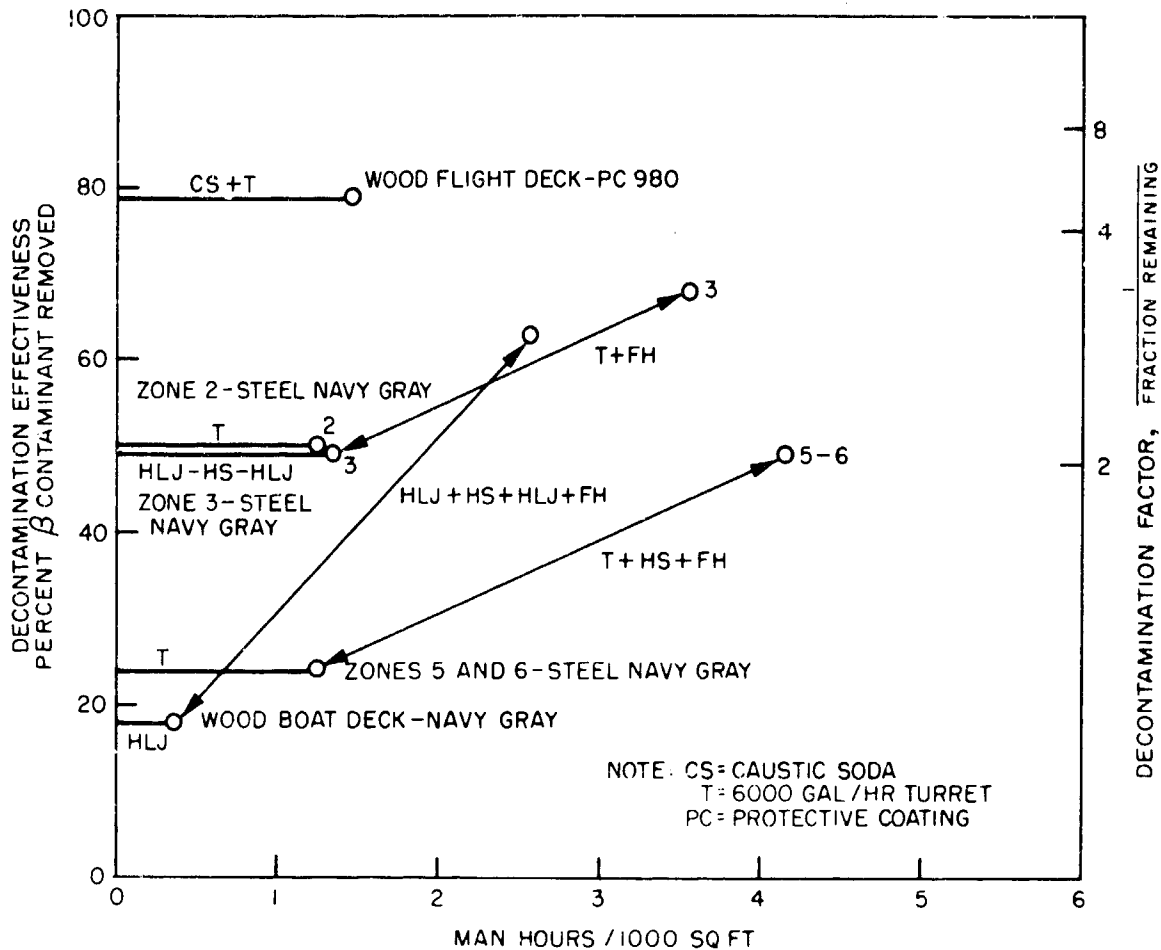

Figure 4.6 Evaluation of decontamination procedures after washdown, YAG 39, Shot 5.

between factors of 2 and 4 for an initial pass and is less than a factor of 8 for a second pass. There is no indication that these factors will be exceeded as the result of improvements in technique or equipment. Further studies should be conducted, however, in an effort to obtain equal results with a reduced manpower effort.

4.5.5 Operational Decontamination, YAG 40, Shot 5. Prior to Shot 5, the topside weather surfaces of the YAG 40 were covered with the Formula 980 protective coating. The development of a technique for the removal of this coating with a caustic soda solution and a firehose washoff (1 1/2-in. firehose) is described in Appendix C. Since the purpose of the decontamination was to reduce the gamma radiation field, decontamination effectiveness was determined by the reduction in gamma dose rate.

Before chemical stripping of the protective coating was undertaken, Zones 1, 2, 3 and 4 were washed down with a 2 1/2-in. firehose to remove the loose contaminant that was being picked up by the clothing of survey and other personnel. As is shown in Figure 4.7, this firehosing reduced the average gamma level in these zones by only 13 percent, but the excessive contamination of clothing ceased to be a problem. The Formula 980 protective coating was removed by spraying a caustic soda solution on the vertical surfaces and mopping it on the decks with swabs. The

application of the caustic caused considerable physical discomfort to personnel.

A 10-to-15-min reaction time was desired, but much of the solution ran off the vertical surfaces immediately and tended to drain from the decks with the sheer of the ship. Because of this, the protective coating was not properly loosened, and the subsequent firehose washing failed to remove it as thoroughly as had been anticipated. The remaining coating retained much of the contaminant associated with it and, consequently, the gamma dose rate was only moderately reduced, as can be seen in Figure 4.7.

A comparison of these decontamination results with those obtained

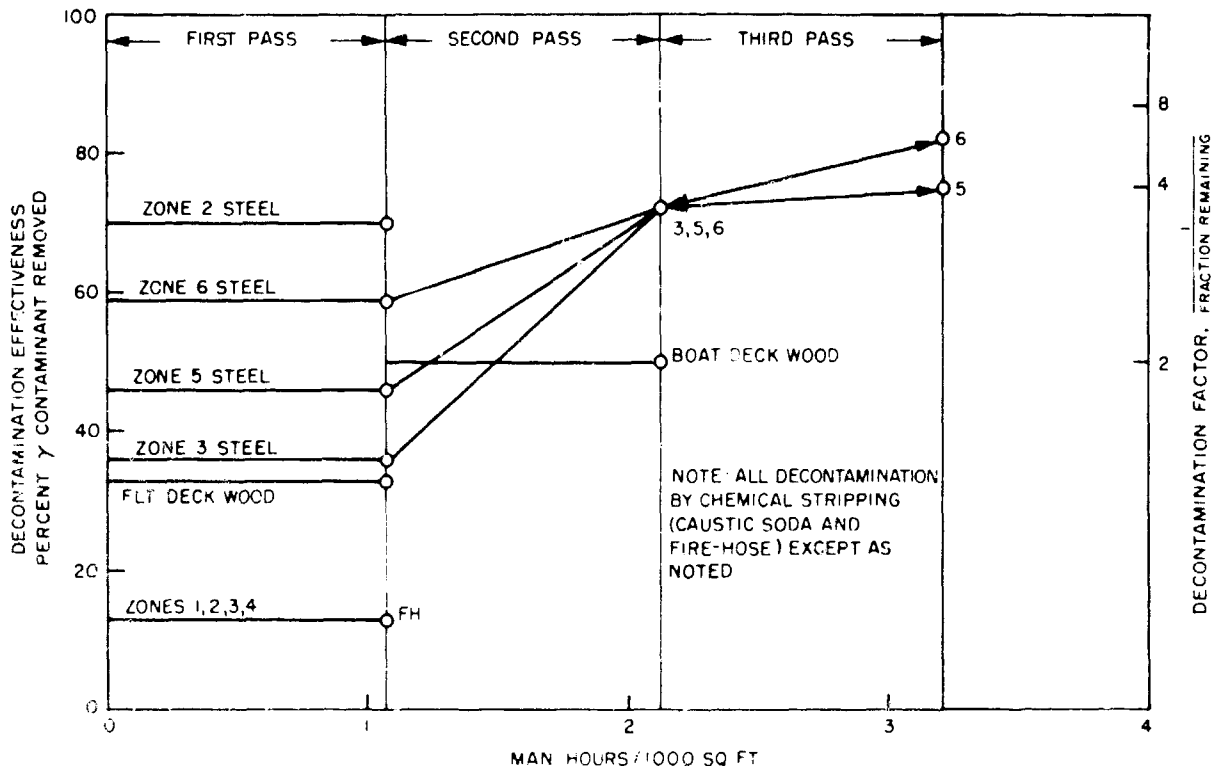

Figure 4.7 Evaluation of decontamination procedures, YAG 40, Shot 5.

by nondestructive experimental methods (Figure 4.2) indicates that the latter were more effective, since the average removal by caustic stripping was 48.8 percent (whereas an overall average of 58.2 percent was removed by the nondestructive procedures). This difference, however, cannot be entirely accepted at its face value; because the beta measurements used to evaluate the experimental procedures were not influenced by extraneous radiation, whereas the indicated reductions in the gamma dose rates by removal of the protective coating were adversely affected by gamma radiation from adjacent surfaces. Assuming that the respective effectivenesses were equal, the relative value of the protective coating consisted of the fact that its removal required an effort of 1.0 man-hr per 1000 sq ft, as compared to an average of 2.0 man-hr/1000 sq ft for the nondestructive procedures. This was an advantage only in regard to this test, since under other circumstances, damage to the ship's paint coat would have

necessitated repainting had the vessel remained indefinitely at sea.

The boat deck and Zones 3, 5, and 6, where exposure of ship's personnel would have been most difficult to avoid, were stripped a second time. As shown by Figure 4.7, this resulted in a cumulative reduction of 72 percent in each zone and 50 percent on the boat deck. Comparing these second passes with the operational decontamination after Shot 2, it is seen that in the latter case the total reduction on the boat deck was 60 percent, 79 percent in Zone 5, and 76 percent in Zone 6 but with the nondestructive procedure requiring more than twice the manpower effort.

After the second pass, the gamma dose rates on the boat deck (and within the living quarters), Zone 5, and Zone 6 were still above an acceptable level. A third pass was made in Zones 5 and 6 and the boat deck was resurfaced with the Tennant machine. This brought the total reduction to 75 percent in Zone 5, 81 percent in Zone 6 (Figure 4.7), and 59 percent on the boat deck (Figure 4.8).

It is unfortunate that sufficient beta measurements were not taken

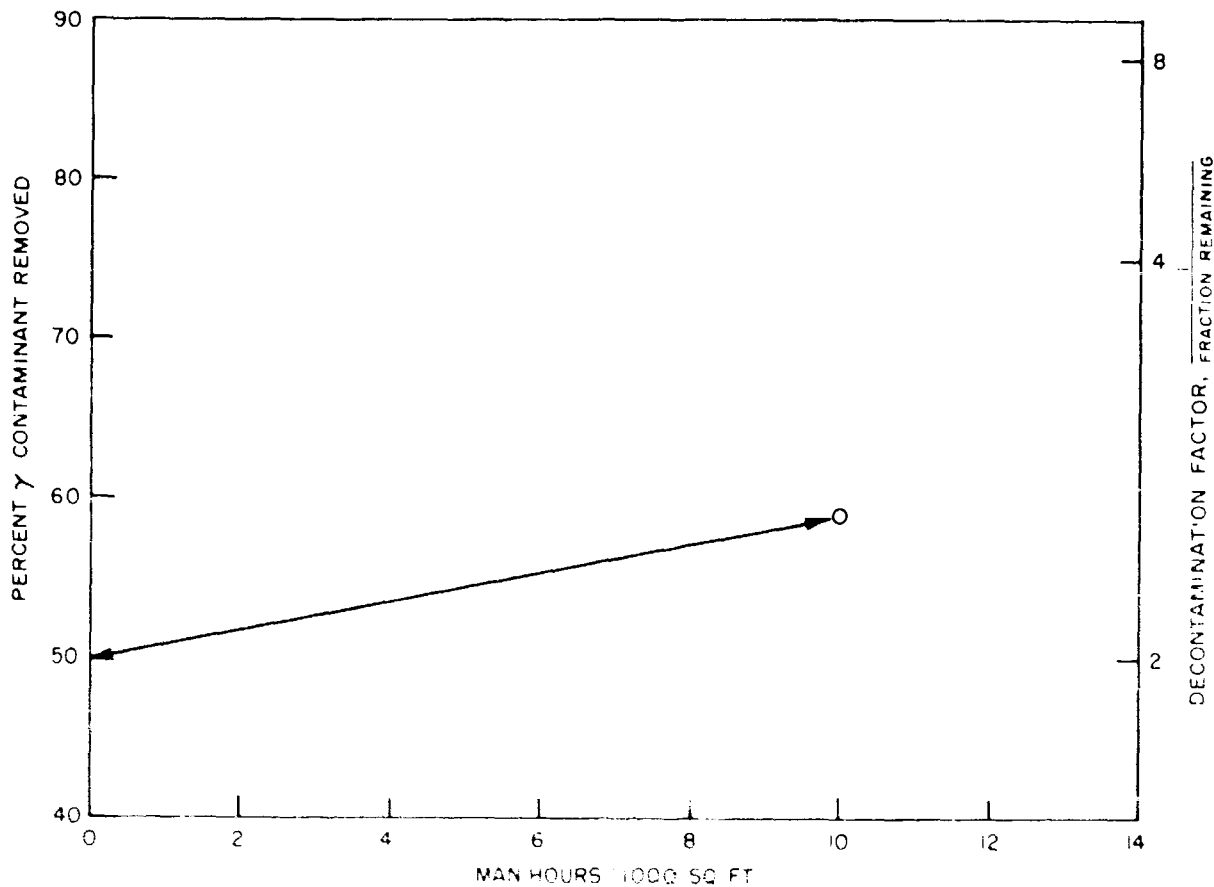

Figure 4.8 Evaluation of Tennant machine resurfacing of wood boat deck, YAG 40, Shot 5.

on the boat deck, since the indicated additional reduction of 9 percent in the gamma level is deceptive. This result was adversely influenced by hot spots, contaminated deck gear and equipment, and the unavoidable presence of contaminated moisture. This is demonstrated by the fact that, in the same operation after Shot 2, the beta measurements (Figure 4.5) showed a further reduction of 30 percent on the boat deck, while



the corresponding gamma readings showed the additional reduction to be only 16 percent. The actual effectiveness of the Tennant machine was much the same in both cases.

For this resurfacing operation, the Tennant machine was equipped with a "revo-tool", which increased the operating rate to 400 sq ft/hr (200 sq ft/hr with a wire brush) and decreased the previous effort of 20.0 man-hr per 1000 sq ft to 10.0 man-hr per 1000 sq. ft, waste-disposal personnel not included. Aurand air-driven, hand cutting tools were used at the bulkhead parting lines, around the boat davits and cradles, and in other areas which could not be reached with the Tennant machine.

The second and third applications of the caustic soda solution caused the removal of the Navy Gray paint and, in some instances, the red lead from large areas of the weather surfaces; but despite this drastic treatment, considerable amounts of the Formula 980 protective coating were unaffected. Thus, this material was unsatisfactory and failed to accomplish its intended purpose. However, a protective coating which could be removed without the use of surface destructive chemicals would provide an effective decontamination procedure. The development of such a coating should be undertaken.

4.5.6 Effect of Washdown, YAG 39, Shot 5. The surveyed gamma dose rate aboard the YAG 39 at 76 hr after Shot 5 was less than that of the YAG 40 by a factor of 11, a difference of 91 percent, indicating that the washdown system was successful in removing a major portion of the arriving contaminant (see Chapter 2). The later decontamination described in Section 4.5.3 was applied to a tenacious residual contaminant. This resulted in a seeming decrease in the decontamination effectiveness obtained with the same procedures on the YAG 40 after Shot 2.

The washdown, therefore, did not increase the effectiveness of subsequent decontamination. It did, effectively reduce the dose rate and permitted the initiation of additional recovery measures at a much earlier time after the contaminating event. Further, although the effort required for the procedures was unchanged, it was not necessary to relieve the teams at short intervals to avoid excessive radiation exposure.

The net effect of the washdown was: (1) an indicated contaminant removal of 93 to 97 percent was achieved (see Chapter 2); (2) a lower residual dose rate was encountered; (3) the total number of men required to decontaminate a given area was reduced; (4) less personnel dosage was expended; and (5) the actual time required for decontamination was 60 percent of that expended on the YAG 40 after Shot 2 and 70 percent of the time for the YAG 40 after Shot 5.

It can be concluded that the washdown system provides an effective method of decontamination and, under equal conditions, is superior to the other procedures tested.

4.5.7 Decontamination versus Decay. The effectiveness of each of the decontamination procedures, as previously discussed, represents only the extent to which the contaminant actually present on the surface was removed. The added effect of decay is not reflected, since all data were corrected to eliminate this factor. Consideration must be given to the influence of natural decay on the tactical decontamination of a ship in a military situation.

Superficially there are two extreme possibilities: (1) that at an early time, i.e., immediately after the contaminating event, the rate of decay is so much greater than the contaminant removal rate that any decontamination effort expended is unjustified from the standpoint of dosage and (2) the extension of a limited decontamination effort over a protracted period, at later times when the decay rate is less rapid or even negligible, fails to adequately reduce the existing radiation level and again results in an unnecessary additional dose to exposed personnel.

The data available from the ship decontamination studies do not permit a determination of the optimum time at which decontamination operations should be undertaken. Such knowledge is potentially important, and a special study should be made to thoroughly explore the problem.

It can be stated conclusively that the tactical decontamination of any ship should be an all hands operation in which every accessible, contaminated surface is attacked simultaneously and thoroughly decontaminated in the least possible time.

4.5.8 Radiation from Deck Gear and Fittings. The average gamma dose rates aboard both ships after termination of the decontamination efforts were influenced adversely by radiation from contaminated rope, steel cables, boat cradles, and similar gear which could not be decontaminated or immediately replaced and from relatively inaccessible objects such as the kingposts and funnel. Attempts to decontaminate the funnel and top of the house were especially unproductive, because of the coating of plastic enamel which had been applied to assist in ship identification from the air. Drain pipes and scuppers became heavily contaminated and remained unaffected by practically unlimited flushing.

4.5.9 Airborne Contamination from Resurfacing (Tennant Machine) Operations. Continuous air sampling showed that the aerosol concentration in the immediate vicinity of the machine did not at any time exceed the task force field tolerance of  $1 \times 10^{-6}$   $\mu\text{c}/\text{cu cm}$  of air. The maximum observed concentration was  $4.3 \times 10^{-8}$   $\mu\text{c}/\text{cu cm}$ . It was found that, without regard to aerosol hazard, the use of respirators was desirable from the standpoint of physical comfort and protection from flying chips.

4.5.10 Wipe Samples. Theoretically, it should be possible to determine, by means of wipe samples taken before and after decontamination, the extent to which loose contaminant is removed from a surface. Practically, however, the accuracy of such a determination is questionable, due largely to an inability to maintain uniformity in the sampling. For example, any variation in contact pressure or in the area of the wipe, between the initial and final sampling, can result in a false indication of the amount of contaminant removed and, similarly, the amount of loose contaminant remaining.

The average beta levels, in microcuries, as measured by the NRDL RBI-12 and as determined by wipes taken at corresponding station locations aboard YAG 40 after Shot 2, are compared in Table 4.1; there is no correlation which would indicate that wipes offer an accurate basis for the quantitative determination of decontamination effectiveness. Even if perfect reproducibility could be achieved with wipe sampling techniques

TABLE 4.1 COMPARISON OF BETA CONTAMINANT REMOVAL ON THE YAG 40 AFTER SHOT 2 AS DETERMINED BY WIPE SAMPLE COUNTS AND RBT-12 BETA SURVEY METER MEASUREMENTS

	Section	Method	Location	Average Beta Readings				Per Cent Remaining	
				Survey		Wipes		Survey	Wipes
				Initial	Final	Initial	Final		
				(uc)		(uc)			
PAINTED WOOD	Zone 1 Flight Deck	S	Port	1533	807	45	2.14	52.5	4.76
		S	Starboard	287(a)	128(a)	2.7	0.33	44.7(a)	12.3
PAINTED WOOD	Zone 4 Boat Deck	B	Port	857	350	103	2.79	40.9	2.69
		B	Starboard	923	365	77	5.1	39.5	6.70
PAINTED STEEL	Zone 2 Steel Deck	C	Port	3975(a)	1487(a)	335	13.9	37.4(a)	4.16
		A	Starboard	1100(a)	512(a)	67	1.52	46.3(a)	2.26
	Zone 5 Steel Deck	S	Port	1800(a)	765(a)	212	1.90	42.5(a)	0.87
		C	Starboard	1300(a)	485(a)	57	3.31	37.3(a)	5.77
	Zone 6 Steel Deck	S	Port	3600	740	50	3.31	20.4	6.62
		D	Starboard	620	260	37	7.24	42.0	11.10

(a) These values are from stations located as near as possible to those where the wipes were taken.

no assurance that any correlation between beta readings and wipe samples is assured. Not only do the beta instruments and wipe samples measure two different radiological conditions, --- local beta contaminant and loose beta contaminant, respectively --- but there is no reason to believe the degree to which decontamination may affect one condition equals that on the other. Wipe samples are valuable, however, from the standpoint of radiological safety and personnel protection in that the detection and measurement (even qualitatively) of loose, easily removable contaminant determines the need for protective clothing and the enforcement of area contamination control measures.

4.5.11 Utilization of Manpower. An average daily total of 25 enlisted personnel were made available by the task force for ship-decontamination work. An increased number could have been employed, if sufficient decontamination equipment and radiological safety facilities had been available.

A decontamination team consisting of a minimum of six men was required for the efficient performance of the individual methods that constituted any of the tactical decontamination procedures. Control of the 2 1/2-in. firehose with 4 NAP fog nozzle, at 100 psig in the line, called for a maximum effort from the six-man team. In the combined operation of hand scrubbing and wet-liquid-jet cleaning, wherein the detergent solution was educted through the jet, four scrubbers, each covering 25 sq ft/min, were able to keep pace with the 100 sq ft/min rate of the jet. The sixth man, in this case, operated the injector unit and prepared the detergent solution.

For purposes of organizational control, the six-man teams were maintained for scrubbing operations in which the detergent solution was dipped from 10-gal cans with the deck brushes. Had sufficient manpower

been available, the potential number of scrubbers would have been limited only by the degree of physical interference; but a six-man team would have been required for each of the 2 1/2-in. firehoses used for the subsequent washoff.

A six-man team was also employed in the operation of the 6000-gal/hr turret. The construction of the turret nozzle was such that three men were required to maneuver it and stabilize it in operation. The bulk and weight of the 2-in. high pressure steam hose made it necessary to have two men standing by to assist when the hose had to be moved. The sixth man was stationed at the injector unit.

Paint-stripping procedures requiring the application of caustic soda solution necessitated some changes in team organization and arrangement. On the decks and other horizontal surfaces where the caustic was applied with swabs and the dissolved or loosened paint subsequently washed off with either the 1 1/2-in. firehose or the 6000-gal/hr turret, the six-man teams were maintained as for experimental decontamination. For bulkheads and deck configurations necessitating pressure spraying of the caustic, two-man spray teams and two-man hose teams (1 1/2-in. firehose) were organized. Because of the necessary time interval between the spraying of the caustic and the firehosing, these teams functioned independently.

The concept of the two-man spray team placed one man at the spray nozzle and the other at the pumping unit. The two-man hose team was adequate and handled the 1 1/2-in. firehose without difficulty.

In the paint-removal operation on the YAG 40, the 1 1/2-in. firehose replaced the 6000-gal/hr turret for deck washing. This made it possible to remove four men from the higher radiation field after the deck had been swabbed with caustic and subsequently to rotate them as relief teams at the firehose.

4.5.12 Stay Time. The radiological situation aboard the test ships at the time of decontamination was not sufficiently critical to cause drastic curtailment of stay time aboard, and the work periods were largely determined by considerations of worker fatigue and physical comfort. The average work period was 30 min in a range from a 15-min minimum, when personnel were wearing special protective clothing and continuous physical exertion was required, to a maximum of 45 min, when cooler clothing could be worn and the physical effort was less strenuous.

Although the work was difficult and the personnel were visibly tired at the end of a 30-min effort, there seems to be little doubt that their fatigue was more the product of heat and humidity than of physical exertion.

4.5.13 Special Protective Clothing. Special protective clothing, consisting of hooded, one-piece suits fabricated of vinyl plastic, rubber-coated, and rubber impregnated materials, were evaluated under actual working conditions for the Bureau of Supplies and Accounts and the detailed results have been reported separately.

In general, this special clothing provided excellent protection from contaminated spray and splash as long as the suits remained intact. The suits were particularly valuable in operations involving the use of caustic solutions.

Without exception, however, they failed to withstand ordinary wear and tear and, because of inadequate ventilation, were extremely uncomfortable and oppressive to the wearer. Certain design features, such as built-in feet and mittens, were found to be disadvantageous.

Except for a few specific operations, a general need for special protective clothing for radiological recovery work is not presently indicated. If adequate personnel-decontamination facilities are available, stock-issue coveralls, gloves, rubber boots, and a suitable head covering are sufficient, at least in temperate climates.

4.5.14 Growth of Radioactivity. In Chapter 5 it is reported that, subsequent to various phases of aircraft decontamination, the fixed gamma detector mounted in the cockpit recorded a slight increase in

TABLE 4.2 DATA FOR ESTIMATING DECONTAMINATION OPERATIONS

Effectiveness Per Cent Cont. Removed		Procedure	Method	No. Men	Method	Net	Man hr per 1000 sq ft	Water gal/min	Steam lb/hr	Deter-	Remarks
Steel	Wood				Rate sq ft per min	Rate sq ft per min				gent lb 1000 sq ft	
68-76	50-60	S	FH	6	100	29	2.5	200	-	-	Set up and stand- by time not included
			HLJ	2	100			15	770	0.5	
			HS	4	100			-	-	-	
			FH	6	200			200	-	-	
45-63	-	A	HLJ	2	100	33	2.0	15	770	0.5	Do
			HS	4	100			-	-	-	
			FH	6	100			200	-	-	
49-63	-	B	HLJ	2	100	33	1.33	15	770	0.5	Do
			HS	4	100			-	-	-	
			HLJ	2	100			15	770	-	
50-70	-	C	FH	6	100	46	2.17	200	-	-	Do
			HS	6	150			-	-	0.5	
			FH	6	200			200	-	-	
38-62	-	D	HLJ	2	100	50	1.33	15	770	0.5	Do
			FH	6	100			200	-	-	
35-51	-	FH	FH	6	100	100	1.0	200	-	-	Do
35-42	-	Turret	Turret	6	80	40	2.5	75	4000	1.3	Removal of resid- ual contaminant Set up and stand- by time not in- cluded
				6	80			75	4000	-	
36-70	-	Strip Coat	Caustic	2	150	32	1.05	-	-	-	Required concen- tration of caustic soda solution varies
			FH	2	40			75	-	-	

gamma intensity over the level observed immediately after completion of the decontamination operation. In the discussion of this phenomenon, it is suggested that it may have resulted from preferential parent-daughter fractionation of one or more isotopes.

The fixed gamma detectors mounted above deck on the YAG 39 and YAG 40 indicated that similar increases in gamma intensity may have occurred after shipboard decontamination. They cannot, however, be detected from the monitoring surveys made with the AN/PDR-TIB survey meters.

4.5.15 Estimating Decontamination Operations. The basic information derived from the ship-decontamination studies is summarized in Table 4.2 as a reference in planning decontamination operations.

#### 4.6 CONCLUSIONS

The test data and information apply to a specific contaminant, delivered as a wet mist and having chemical and physical properties which have been described in another report (Reference 7). Dry or slurry contaminants might have produced varying results.

The washdown system is the most-effective decontamination counter-measure presently available and will remove 93 to 97 percent or more of an arriving contaminant. This removal gives a decontamination factor in the range of 14 to 20 (Chapter 2). The decontamination effectivenesses of the tested procedures lie between factors of 2 and 4 for an initial pass and did not exceed a factor of 8 for a second pass. No significant increases in effectiveness can be expected through further development, but improvement of techniques and equipment can provide more thorough surface coverage and reduce the manpower effort.

The procedure which provides effective decontamination with minimum equipment and reasonable effort (2.17 man-hr/1000 sq ft) consists of firehosing, hand scrubbing with a salt-water-compatible detergent, and firehosing.

Firehosing alone has a possible decontamination factor of 2.0 on painted steel and requires a minimum effort of 1.0 man-hr per 1000 sq ft.

Protective coatings have a potential value both as a barrier to radioactive contamination and as a means of facilitating decontamination, but further development and a major improvement are necessary.

Wood decking, even when thoroughly payed and well painted, is more difficult to decontaminate than painted steel. Surface removal may be required if a decontamination factor greater than 2.5 is required.

Deck armament, deck machinery and gear, masts, cargo booms, and similar equipment, unless decontaminated or removed, will continue to maintain a radiation field above deck and in adjoining interior spaces.

The rate of natural decay may prove to be an important factor in the determination of the time at which it is profitable to begin decontamination operations following a contaminating event; since it is possible that, at early times, a contaminant may decay more rapidly than it can be physically removed.

Tactical decontamination of a ship should be a mass operation in which all accessible contaminated surfaces should be attacked simultaneously and thoroughly decontaminated in the least possible time. Any lesser effort, in which a limited operation is extended over a protracted period, will fail to adequately reduce the overall radiation level and will result in an unnecessary additional dose to exposed personnel.

#### 4.7 RECOMMENDATIONS

Equip all combat and support vessels with some adequate form of washdown system.

Adopt an interim procedure consisting of firehosing, scrubbing with detergent, and firehosing for tactical decontamination.

Determine a reliable rate of decay of nuclear fission products at early times so that recovery operations can be scheduled to obtain maximum effectiveness.

Prepare decontamination bills for ships with and without washdown, utilizing all available manpower to decontaminate the total weather surface in the least time possible.

Eliminate wood decking wherever possible. If wood decks must be retained, they should be thoroughly payed, sealed, painted, and maintained in first-class condition at all times. Carrier flight decks should be sealed with a more-effective material than flight-deck stain No. 21. Redesign or modify weather decks to facilitate the runoff of contaminated liquid waste. Remove or relocate deck obstructions which tend to impede drainage.

Reduce deck machinery, equipment and gear to a minimum. Provide disposable covers for all such remaining items.

Provide adequate stocks of decontamination equipment, materials, and approved protective clothing as ship's allowance items.

Establish and conduct training programs to familiarize personnel with the decontamination procedure as it applies to their particular ship.

Further investigate the use of the 6000-gal/hr hot-water turret as a decontamination method.

Continue the development and testing of protective coatings.

Investigate the use of chemical paint strippers as a practicable procedure for the tactical decontamination of ships.

Improve the equipment and technique for decontamination by non-destructive procedures to obtain more-thorough surface coverage and reduce the manpower effort involved.

## Chapter 5

# AIRCRAFT WASHDOWN AND DECONTAMINATION

J. E. Howell

W. S. Kehrer

A fighter-type aircraft was installed on the No. 5 hatch of each of two test ships. A special configuration of washdown nozzles was installed around the aircraft on the YAG 39 to provide an effective distribution of water on the exterior aircraft surfaces. No countermeasures were employed on the aircraft installed on the YAG 40. Recording gamma detectors were installed in the cockpit and on the deck forward of each aircraft.

After each test, the aircraft and the gamma instruments were removed from the ship and transported ashore to the decontamination site. Material damage studies were made by inspection of the aircraft and by cockpit and radio checks. A detailed beta survey was made to determine the contamination distribution. Decontamination methods and equipment were evaluated by using data from fixed gamma recording instruments and portable survey meters.

The results from these tests indicated that the washdown was effective as a countermeasure when employed under conditions similar to those at Operation Castle. Effectiveness of the washdown after Shots 4 and 5 was 94 and 95 percent, based on reduction in dose rate.

The immediate effect on the aircraft of the salt-water washing and decontamination operations thereafter was not serious. In all cases, the engines started and the radio checked out, but in some cases the magneto dropoffs were excessive. No other effects which would prevent these aircraft from being flown were noted.

The effectiveness of the initial decontamination of the aircraft was influenced by the type of contaminant and by the number of rainstorms that occurred between the contaminating event and the decontamination. It is estimated that up to 35-percent removal of contamination may be effected by rainstorms during any period for several days following contamination.

On aircraft not exposed to rainstorms or washdown prior to decontamination, the maximum decontamination efficiency considering the decontamination effectiveness, time and manpower, is obtained by using one fire-hose or hot-liquid-jet wash, either salt or fresh water, followed by one thorough scrubbing with detergent or Gunk solution, with a final fresh-water rinse.

On aircraft subjected to severe rainstorms or washdown prior to decontamination, the maximum decontamination efficiency is obtained by one thorough scrubbing with detergent or Gunk solution with a final fresh water rinse.

The final rinse may be salt or fresh water, as far as decontamination is concerned, but fresh water has been specified to eliminate the corrosive effects of the salt water.



The contamination distribution on the aircraft was not uniform and depended to a great extent on the course and speed of the ship, the direction and velocity of the wind, and the type of contaminant.

## 5.1 OBJECTIVES

The general objectives of the aircraft phase of Project 6.4 were to: proof test the washdown countermeasures on aircraft; evaluate decontamination procedures for parked aircraft subjected to radioactive fall-out; and ascertain the radiological situation on them. These objectives required the following specific determinations: (1) washdown effectiveness on aircraft; (2) extent of material damage caused by salt water washing; (3) effectiveness of various decontamination procedures; and (4) contamination distribution.

## 5.2 BACKGROUND

Studies, based on data from laboratory investigations and tests at Operation Crossroads, had been conducted at NRDL to determine the extent to which countermeasures are required and the optimum decontamination procedures needed for contaminated aircraft. Although conclusions from these studies were tentative, they provided sufficient information to plan a full-scale test for aircraft in a situation likely to be encountered in nuclear warfare.

In 1952, simulant tests conducted aboard the USS SHANGRI LA (Reference 2) included investigations to determine the effectiveness of a washdown system in reducing the level of contamination on an aircraft subjected to a radioactive fallout. These tests were made with the washdown nozzles installed on the flight deck around two aircraft. The results indicated that the washdown could provide a significant reduction in contamination but that the distribution of water over the surfaces aft of the leading edges was not adequate. The results most nearly approaching the potential effectiveness of the washdown were obtained when water distribution was enhanced by maneuvering the ship. Thus, it became evident that the effectiveness of the washdown countermeasure on aircraft exposed to radioactive fallout would be satisfactory if efforts were made to provide the best-possible water distribution on a carrier deck holding aircraft stacked in the normal way.

Prior to Operation Castle, an aircraft scheduled for salvage was obtained from NAS Alameda and used to study the distribution of water on aircraft surfaces. Nozzles like that in Figure 5.1 were placed around the aircraft in temporary mountings in a configuration which gave the water coverage shown in Figure 5.2. This test indicated how additional nozzles were to be added to the ship's system to provide adequate washing of the aircraft.

Laboratory and engineering scale studies had been conducted at NRDL to determine the effectiveness of various decontamination methods and the effect of different aircraft surfaces on retention of contaminant and on the decontamination performance. Flat surfaces having relatively small areas were used in these tests. Decontamination of operating

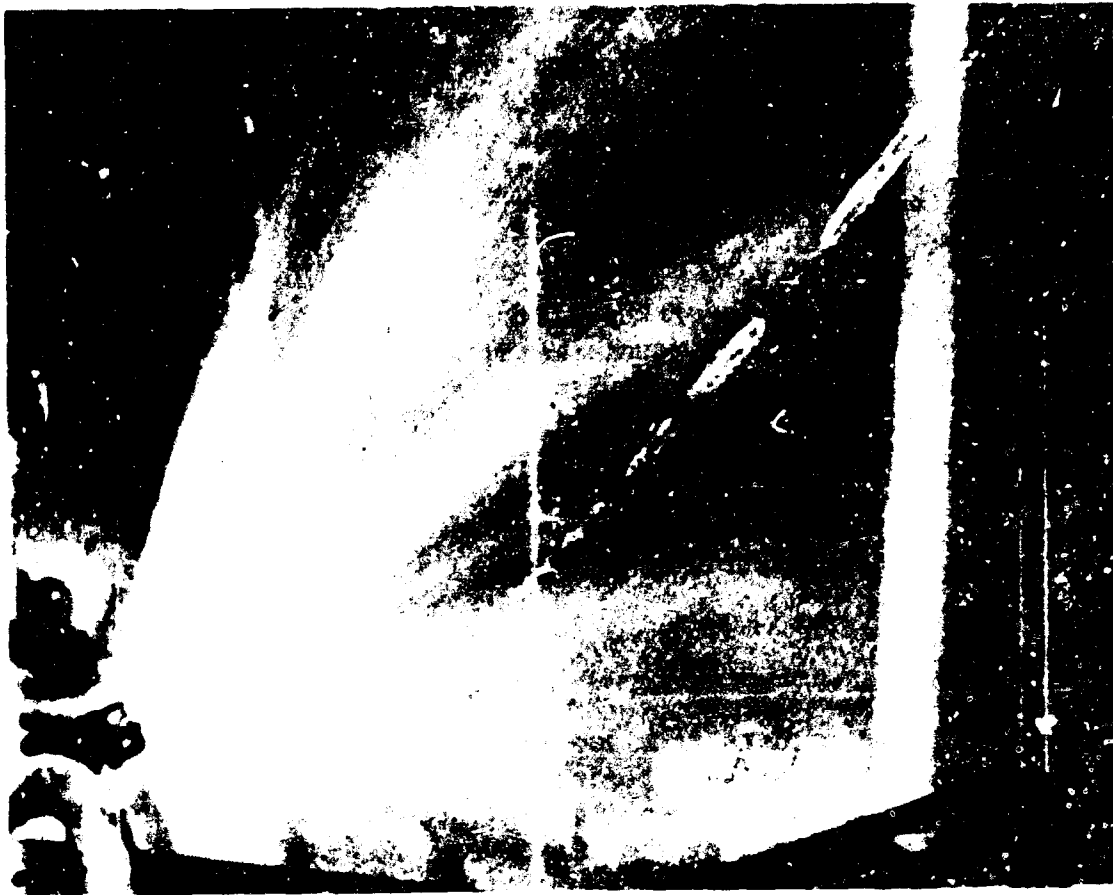

Figure 5.1 Washdown nozzle in operation.



Figure 5.2 Preliminary washdown system for aircraft.

aircraft had been accomplished after aircraft had flown through a contaminated cloud, (Reference 8) but no studies had been made on parked Naval aircraft subjected to a radioactive fallout.

From the foregoing material, it is clear that further information about the contaminant distribution on aircraft, the effectiveness of aircraft decontamination procedures, decontamination equipment, and supply, time, and manpower requirements were all needed to complete the aircraft decontamination studies.

Since there were more combinations of methods of decontamination to be tested than available aircraft, test plates were substituted for additional aircraft. Three sets of plates were used on each test---one to be decontaminated by the same methods as used on the aircraft, the remaining two to be decontaminated by the methods used on the test aircraft after the other two shots. By this means, the test plate results could be used to estimate the aircraft decontamination effectiveness under various test conditions.

To obtain information on the effects of the salt water used in the washdown and decontamination procedures, the aircraft engines were turned up before the tests and as soon as possible after the washdown and decontamination of the aircraft were completed. Also, a visual inspection of the exposed ferrous parts of the aircraft was made about the same time to detect salt-water damage.

The test procedures and accumulation of data were designed not only to meet these needs but also to obtain information for use in the tactical situation (Reference 9). Tactical decontamination (or decontamination during the tactical situation) is defined as those procedures which are required to permit tactical operations from the time of an atomic attack to the completion of the operational mission of the aircraft, its carrier, or the task group.

### 5.3 INSTRUMENTATION

The instrumentation for the aircraft decontamination phase of Project 6.4 was primarily concerned with instruments for fixed gamma recording and means for making standardized beta and gamma surveys. Equipment also had to be provided for the decontamination operation.

5.3.1 Fixed Gamma Recording. A fixed gamma recording instrument was installed in the cockpit of each aircraft and designated as Station 69. Its purpose was to determine the radiation intensity and dosage to the pilot at any time or for any time period.

A similar instrument was installed on the No. 5 hatch of each ship just forward of the starboard wing and was designated as Station 70. This station was chosen as the ground or deck reference in determinations of intensity and dosage in the immediate vicinity of the aircraft. It was also a reference station on the ship for comparison with other deck stations. Locations of the fixed gamma recording instruments are shown in Figures 5.3 and 5.4; details of their operation are given in Chapter 8.

These instruments provided a continuous record of the gamma radiation intensity and dosage aboard ship for approximately 70 hr after burst. When the aircraft were removed from the ships to the decontamina-

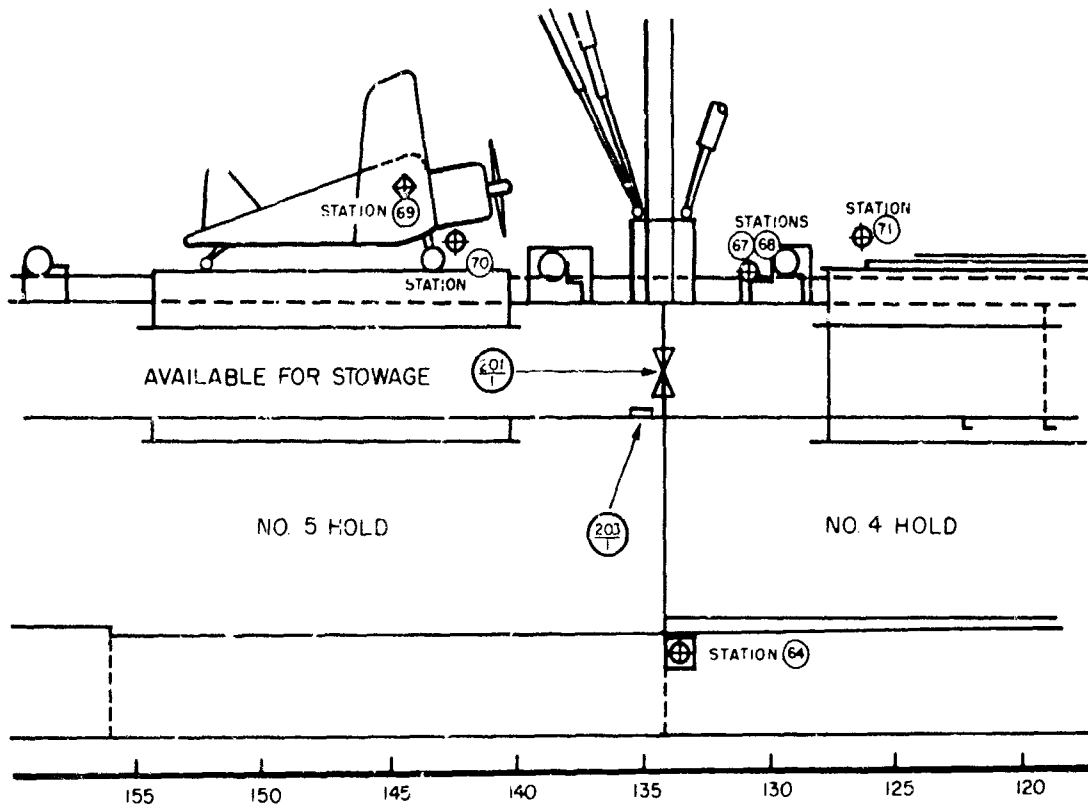

Figure 5.3 Location of fixed gamma recording stations.

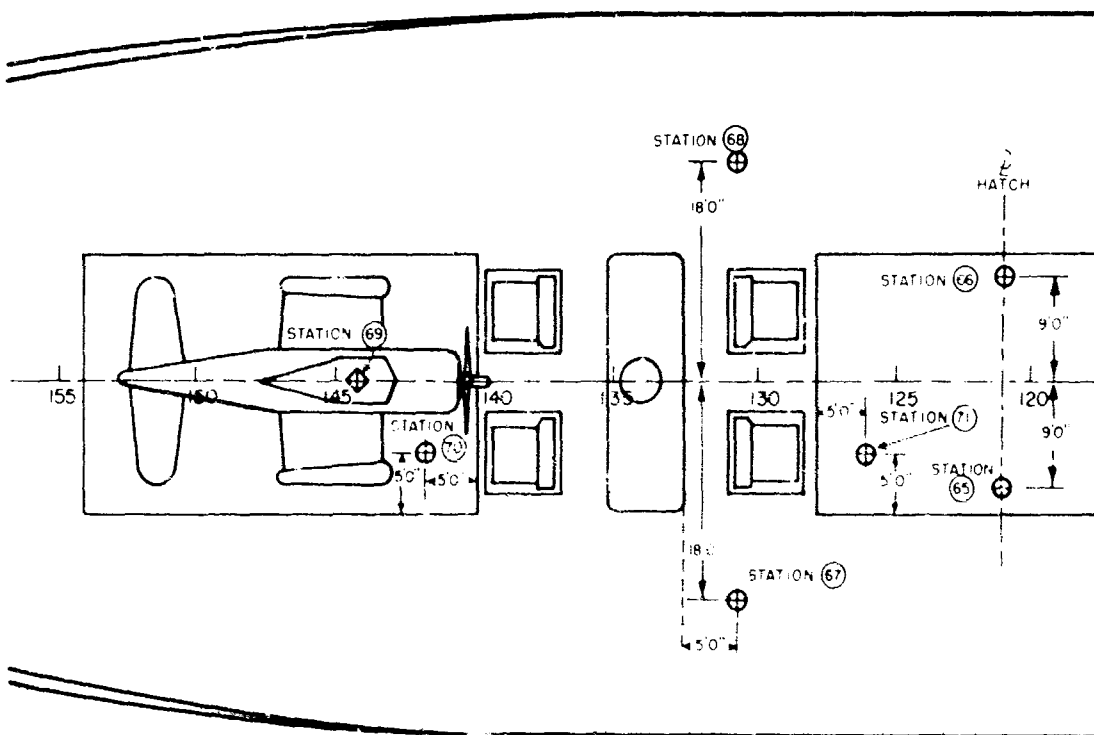

Figure 5.4 Plan view of the fixed gamma recording stations.

tion pad ashore after each test, the instruments were removed at the same time and set up around the aircraft similar to their former locations aboard ship. A continuous record of gamma radiation intensity was made during the decontamination operations.

5.3.2 Surveys. A definite pattern of survey points was used, and a standardized method was followed in taking beta and gamma surveys on the aircraft. Each aircraft was marked with 56 identical stations, which gave a fairly even distribution of locations according to area and types of surfaces (vertical, horizontal, etc.). Figure D.37, Appendix D, shows the location of all the regular survey stations on the aircraft. A typical view of some of the survey points is shown in Figure 5.5. A uniform technique was used by all the monitors in taking both the beta and gamma survey readings. The instruments were held about 1/2 in. from the surface with the bottom and left side of the instrument over the lines marking the survey point. Readings were taken with the beta and gamma survey instruments at all of these locations before and after each decontamination procedure, Figure 5.6. The average of these individual readings (approximately 50) for all surveys except those on the aircraft aboard the YAG 40 after Shot 2 was used in calculating the beta and gamma decontamination effectiveness for the various shots. After Shot 2, there were 20 extra stations on the aircraft aboard the YAG 40; their locations are shown in Figure D.38, Appendix D.

Beta readings were taken with the NRDL RBI-12 survey instrument. Because these readings are probably an accurate representation of the beta activity on the aircraft surface, they were used for the contamination distribution studies.

Gamma readings were taken with AN/PDR T1-B survey instruments. These readings, especially those taken on the outside vertical wing sections and the sides of the fuselage, undoubtedly included not only the radiation from the area directly under the instrument but also background radiation from the contaminant on the opposite side of the wing, the fuselage, and the other wing.

Wipe samples were taken on the aircraft surfaces before any decontamination was begun and again after certain decontamination processes were completed. Approximately 3 sq in. of surface area was wiped each time with standard chemical filter paper.

The survey personnel were furnished by the survey group but operated under the supervision of the aircraft investigators. Details of the organization and training of survey personnel, instrument calibration and evaluation, and the procedure for obtaining and counting wipe samples are given in Chapter 9.

5.3.3 Decontamination Equipment. All the equipment used in the decontamination operations was commercially manufactured and was readily available with the exception of the heavy-duty cleaner<sup>1</sup> (Figure 5.7). This heavy-duty cleaner was one of six especially manufactured for the Army Chemical Corps. Although this particular cleaner is not a commercial item, its main components, the steam generator and hot-liquid-jet unit are available. The cleaner was equipped to provide a concentrated

<sup>1</sup> Mfg. by Vapor Heat Corporation, Chicago, Illinois.



Figure 5.5 View of cockpit area showing the condition of the painted surfaces and some of the survey points.

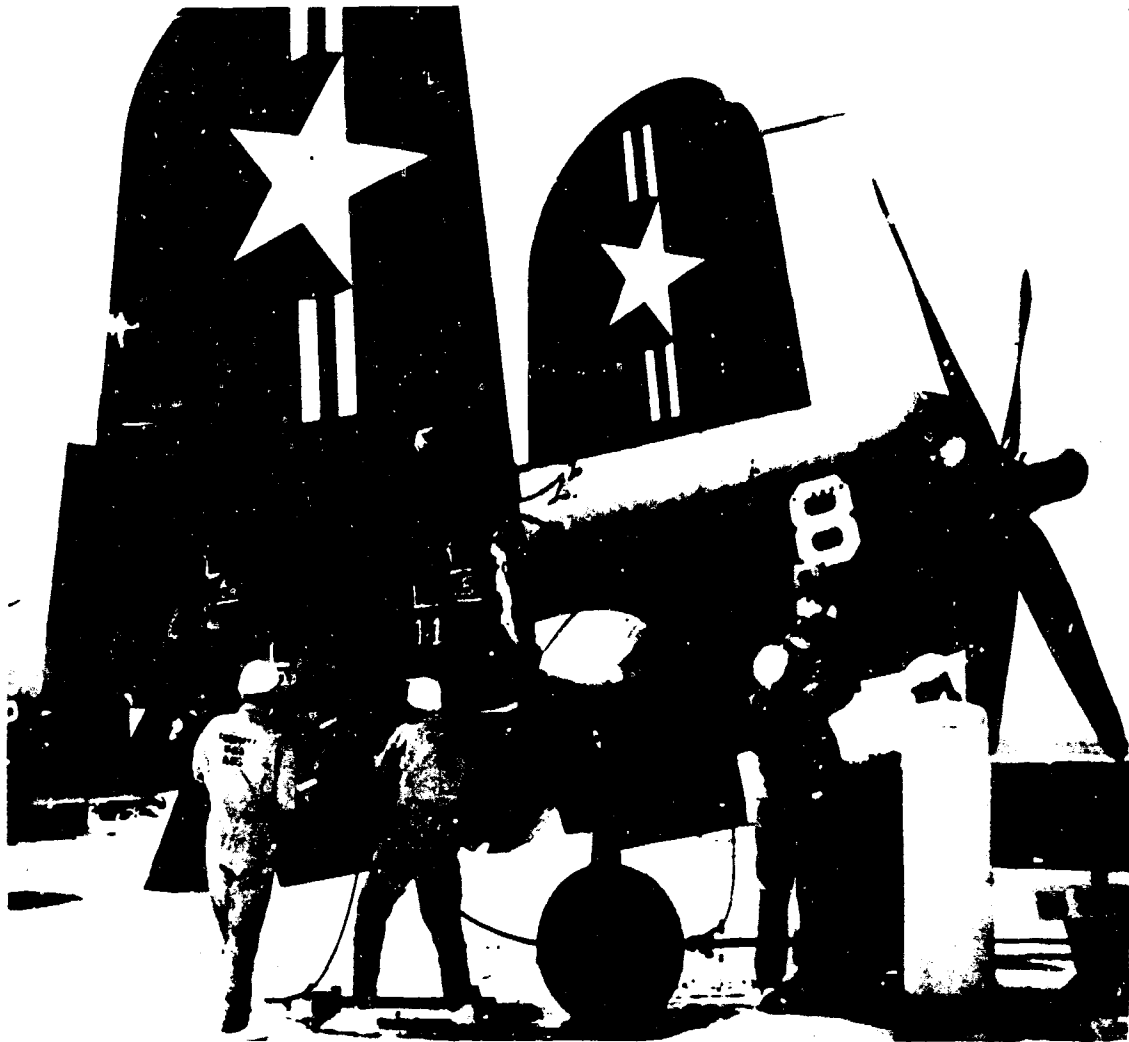

Figure 5.6 Survey teams taking beta and gamma survey readings. The white dome in the right foreground contains the fixed gamma detector Station 70.

solvent, a steam vapor, or a cold rinse, but these features were not used during the decontamination operations.

The hot-liquid-jet utilizes steam passing through a venturi to pick up both water and a detergent solution and combines them into the hot-liquid-jet (see Figure 5.8). Since the fresh-water supply is limited aboard ship, salt water was used part of the time as the water supply for the decontamination operations. The detergent solution was a 20 percent solution by weight of C-120 detergent in salt water. The hot-liquid jet entrained 5 percent of this solution, thus giving a 1-percent detergent solution at the nozzle. The steam-supply pressure to the hot-liquid-jet unit was approximately 100 psig and the inlet water pressure requirement is over 7 psig. These conditions produced a 1000-gal/hr hot liquid jet at a temperature of 170°F and a pressure of 180 psig. The flow charts and equipment hookup for the hot-liquid jet with fresh and with salt water are shown in Figures D.16 and D.17, Appendix D.

Firehosing was done with a three-way (open, fog, and closed) 1 1/2-in. nozzle and at a pressure of about 80 psig. The flow chart and equipment hookup for washing with the firehose is shown in Figure D.14, Appendix D.

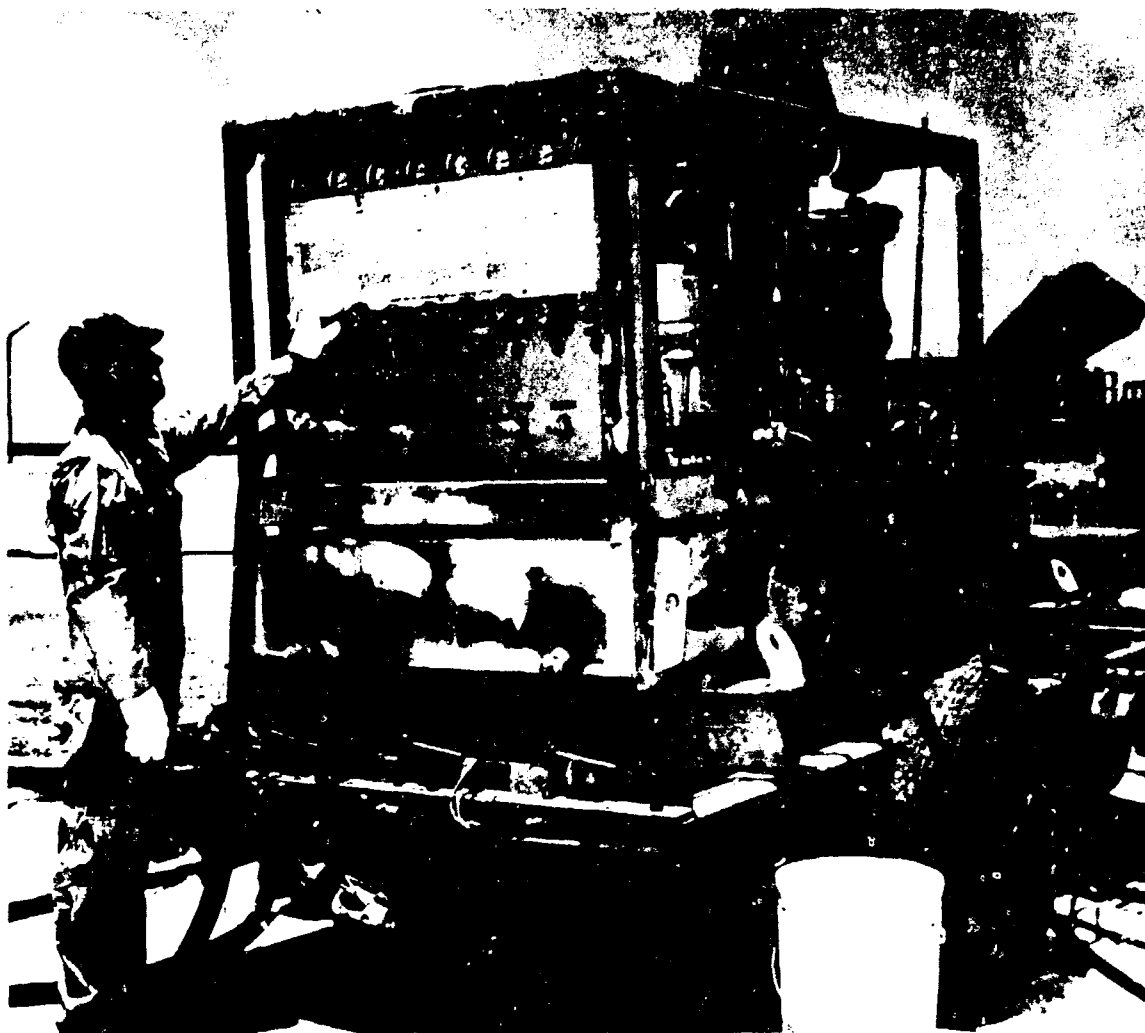

Figure 5.7 Rear view of heavy duty cleaner showing control panel and hook-up for use as a steam generator.

#### 5.4 OPERATIONS

Two test ships, the YAG 39 equipped with a washdown system and the YAG 40 without one, participated in Shots 1, 2, 4, and 5 with aircraft and test plates aboard. During the test operations, these ships were maneuvered through the fallout area together, but because of circumstances they did not maintain the desired positions at all times. Shots 2 and 4 were postponed 14 days and 10 days, respectively. This delay exposed the aircraft and test plates aboard the ships to weather during this period. Shot 5 was fired on schedule. No data were obtained from Shot 1, because the ships did not receive any significant fallout. The best data for washdown evaluation were obtained from Shots 4 and 5; the best data for the effectiveness of decontamination procedures were obtained from Shots 2 and 5.

The aircraft were Navy F4U's and were loaded on the No. 5 hatch of each ship with their wings in the vertical positions approximately two days before the ships departed for Bikini. A YC-type Naval barge was used to transport the aircraft to the ship and a construction-type crane in an LCU was used to lift them onto the ships. The fixed gamma





Figure 5.8 Operator adjusting control valves on the hot-liquid-jet unit. The unit is secured on top of the barrel which holds the detergent solution.

instruments were installed and tested at this time.

A panel rack holding nine test plates was placed on each of the two ships for each test. It was located in all tests alongside the rear of the No. 5 hatch on the starboard side facing forward. The rack was constructed so that the plates were inclined at about  $30^{\circ}$  from the horizontal. The  $1/8$ -in. aluminum test plates were each 16 in. by 16 in. and were painted on one side with one coat of wash primer, two coats of zinc chromate and two coats of sea blue lacquer.<sup>1</sup> The plates were

<sup>1</sup> Specification MIL-L-7178.

painted in November 1953 at MINS, and were protected from weathering until they were placed on the panel racks the day before the event was first scheduled.

On completion of test runs, the aircraft, instruments, and test plates were unloaded as soon as the radiological situation permitted and transported to the Air Force decontamination pad on Site Fred. At this time, the aircraft aboard the YAG 39 was given a thorough inspection for material damage and that aboard the YAG 40 a cursory one; the fixed gamma recording instruments were hooked up and the initial beta survey for contamination distribution were made before decontamination was begun. Thorough inspection for material damage of the YAG 40 aircraft was postponed until after the decontamination was completed, because of the high initial contamination.

5.4.1 Washdown. Only the aircraft on YAG 39 was subjected to washdown during the tests. As can be seen in Figures 5.9 through 5.11, complete water coverage on the aircraft surfaces was not maintained all the time. The distribution pattern of the water from the washdown system was largely dependent upon the direction of the wind relative to the ship and the ship's speed. The condition where minimum effectiveness from the washdown system might be expected is illustrated by Figure 5.11. Maximum effectiveness of the washdown system can be achieved by maneuvering the ship in a sinusoidal course into the wind during the fallout period. Such a course was not steered during the fallout periods of Operation Castle.

5.4.2 Material Damage Inspection. The aircraft on YAG 39 were subjected to a salt-water washdown aboard ship, and the aircraft from both ships were subjected to liquid decontamination methods employing salt water at the decontamination site. To approximate the gross damage done by this liquid treatment, a thorough material damage study was made on the YAG 39 aircraft immediately at the decontamination site and on the YAG 40 aircraft after decontamination had been completed. This study consisted of a cockpit check, radio check, and a visual inspection of the aircraft for corrosion and visible damage. The items included in these checks are listed in Table D.1, Appendix D.

The four aircraft used in this project had been given Type C preservation at Alameda NAS in January 1954 before they were shipped to the test site. Two aircraft were de-preserved prior to Shot 1, used in Shots 1 and 2, and re-preserved. Two other aircraft were de-preserved prior to Shot 4, used in Shots 4 and 5, and then re-preserved. Table 5.2 shows when the aircraft were de-preserved, re-preserved, and how many days they were aboard the test ships without maintenance; it also summarizes the cockpit and radio checks.

These aircraft were near the end of their service life. At the test site, they were subjected to extreme tropical conditions with limited maintenance, because only two Navy maintenance personnel were available to work on them. The maintenance personnel were able to keep the engines in operating condition but not at top performance.

5.4.3 Decontamination Methods. Three methods of decontamination were used: (1) salt-water washing with fire hose; (2) fresh- or salt-

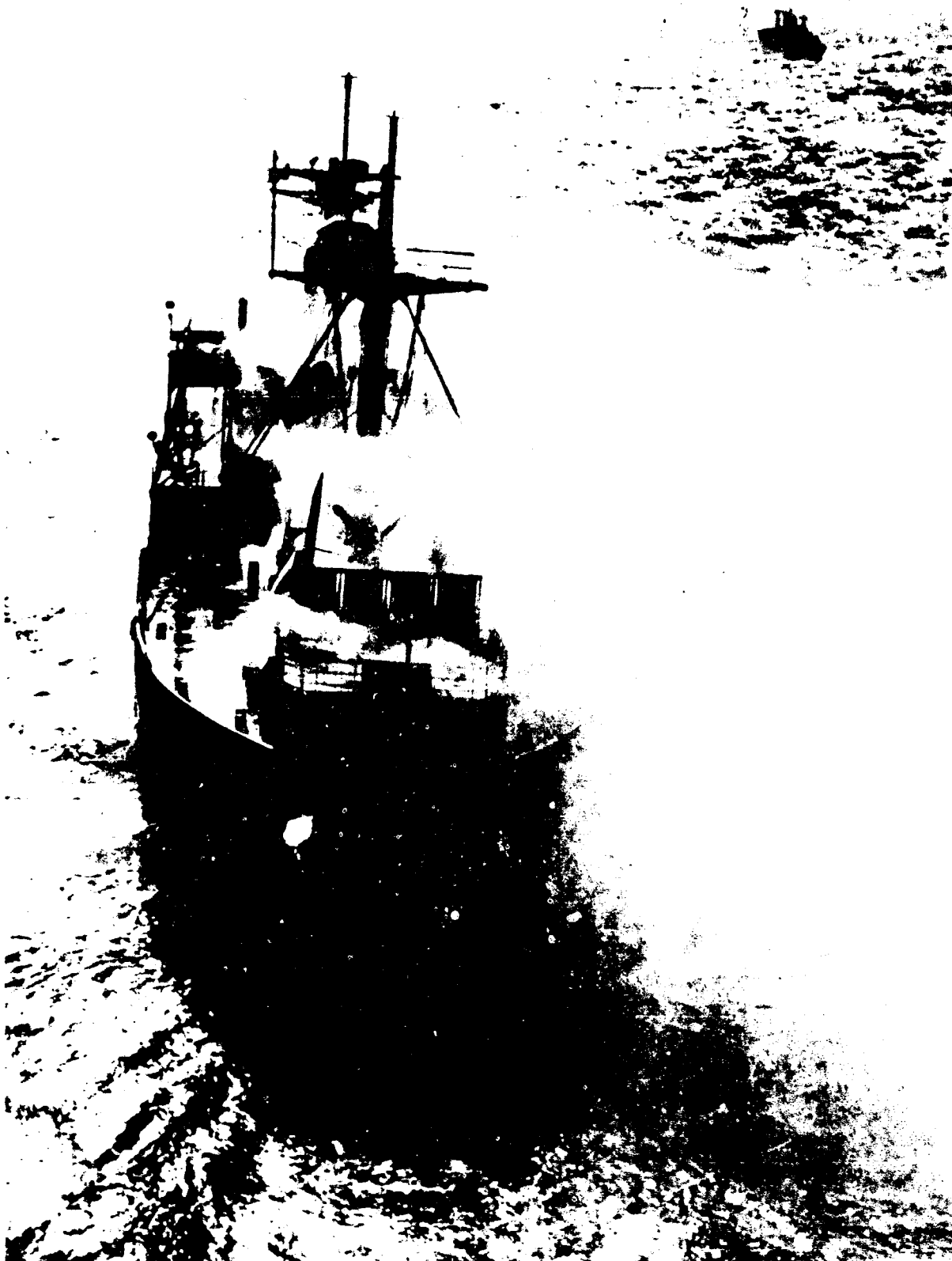

Figure 5.9 Washdown system in operation on the YAG 39,  
view from aft.

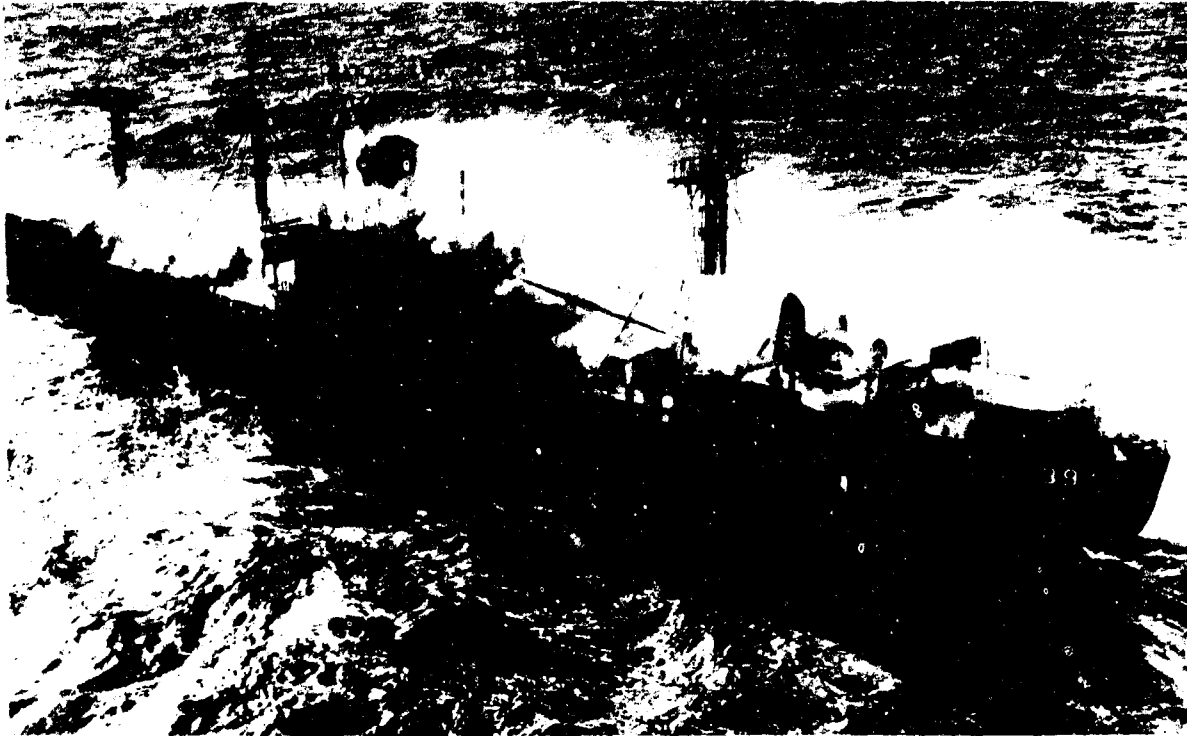

Figure 5.10 Washdown system in operation on the YAG 39, view from port side.

water washing with a hot-liquid jet; and (3) scrubbing with detergent or Gunk followed by rinsing with the hot-liquid jet using fresh water. Table 5.1 gives the methods of decontamination used and the component steps.

Tactical emergency methods of decontamination were used first on the aircraft and test plates and were followed by tactical operational and industrial methods of decontamination.

Decontamination by firehosing was done by two crews who began at the nose of the aircraft and proceeded around each side, washing the surface from the top down and maintaining such an incident angle between the water stream and the surface that a minimum amount of splash was reflected towards the operator. A fork lift was used to raise one of the nozzle men and hose, as shown in Figure 5.12, to wash the top of the fuselage and engine. The wing tips were left in the vertical position during this decontamination. Each crew directed its stream of water over the fuselage and washed the inboard edge of the wing tip on the side of the plane opposite from the crew. During the first decontamination effort on the aircraft, from the YAG 40 after Shot 2 only one 1 1/2-in. firehose and nozzle was used for the entire operation. The second decontamination of the same aircraft was accomplished with two crews using two 1 1/2-in. firehoses and nozzles. The three-way nozzles were used in their open position.

The procedure in decontaminating with the hot-liquid jet was essentially the same as with the firehose. However, only one hot-liquid-jet unit and lance was used. The aircraft was roughly divided into six sections of approximately equal areas, so that each could be washed with

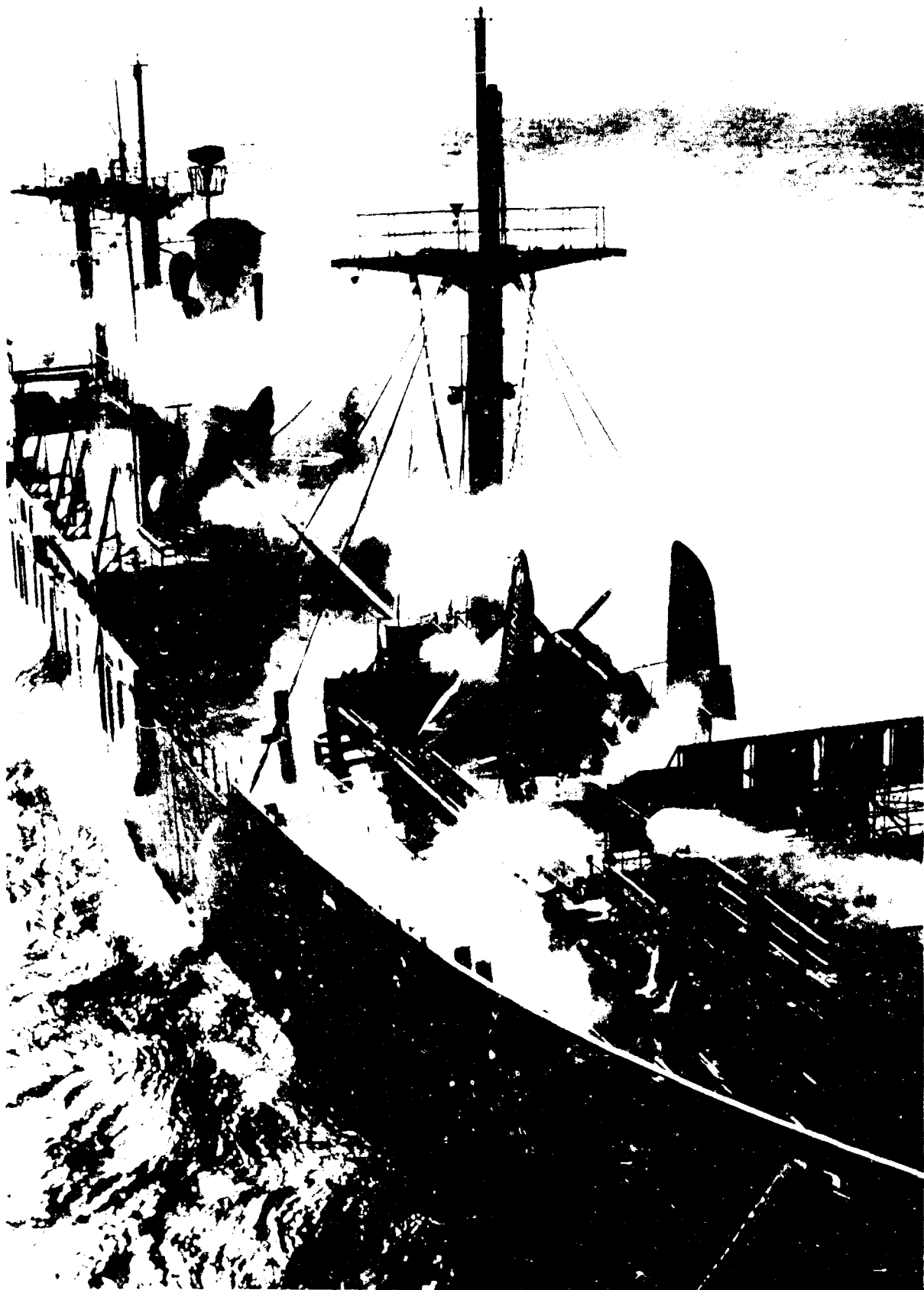

Figure 5.11 Washdown system in operation on the YAG 39,  
view from after port quarter.

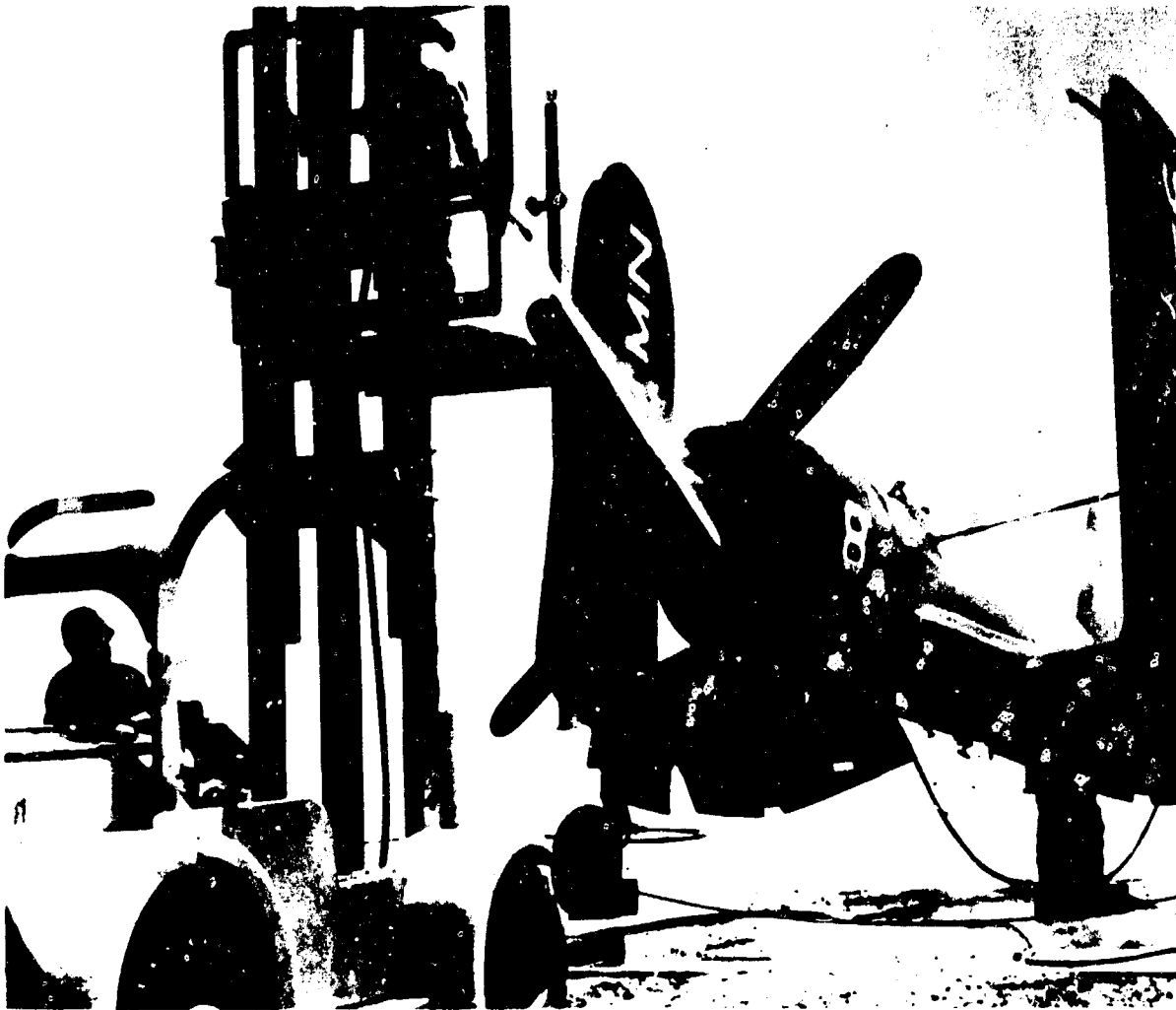

Figure 5.12 Rinsing with the hot liquid jet showing how a fork lift was used to allow the nozzle-man to wash to top of the fuselage and engine.

the detergent solution and then rinsed with clear water before the area dried. When all the sections had been treated with detergent and rinse, the entire aircraft was then given a complete rinse with clear water. The same procedure was followed with both the fresh and salt-water supply.

The procedure used in decontamination by scrubbing follows: When C-120 detergent was used as the cleaning agent, the area of the aircraft was again roughly divided into six sections. The hot-liquid jet was used to apply a detergent solution to the first section and then turned off. Next, three to six scrubbers with long-handled brushes and buckets of detergent solution scrubbed the section in such a manner that approximately 10 strokes of the brush were applied to all the surface. The clear hot-liquid jet (without detergent) was then used to rinse this section. The same procedure was used in turn on all the other sections. When all the sections had been scrubbed, a final overall fresh water rinse was given the entire aircraft. This procedure was called the "single scrub." The "double scrub" method consisted of repeating the scrubbing and rinsing operation on each section before moving to the next without monitoring between scrubblings.

When C-147 (Gunk) was used as the cleaning agent, a solution of

TABLE 5.1 DECONTAMINATION METHODS AND THEIR COMPONENT STEPS

General Methods	Tactical Emergency		Tactical Operational	Industrial	
	Firehosing	Hot liquid jet with fresh water	Hot liquid jet with salt water	Scrubbing with detergents <sup>(a)</sup>	Scrubbing with Gunk <sup>(b)</sup>
Component Steps	Firehose - salt water, followed by fresh water rinse at end of day or decontamination	Hot liquid jet - fresh water with detergent, followed by hot liquid jet - fresh water rinse	Hot liquid jet - salt water with detergent followed by hot liquid jet - salt water rinse followed by fresh water rinse at end of day or decontamination	Scrub with detergent followed by hot liquid jet-fresh water rinse	Scrub with Gunk, followed by hot liquid jet - fresh water with detergent rinse followed by hot liquid rinse

(a) Detergent is C-120

(b) Gunk is C-147, now designated as MIL-C-7122, Type 1

TABLE 5.2 SUMMARY OF MATERIAL DAMAGE INSPECTIONS

Shot and YAG the Aircraft Was On	Aircraft No.	Date De-preservation Started	Date Loaded Aboard YAG	Date Unloaded from YAG	Days Without Maintenance	Material Damage Inspection		Date Re-preservation Starts
						Cockpit Check	Radio Check	
1-39	81724	17 Feb.	25 Feb.	4 Mar.	7	Satis.	Satis.	-
1-40	81624	17 Feb.	25 Feb.	4 Mar.	7	Satis.	Satis.	-
2-39	81724	-	10 Mar.	29 Mar.	19	Right Mag. drop excessive	Satis.	13 Apr.
2-40	81624	-	10 Mar.	31 Mar.	21	Satis.	Satis.	13 Apr.
4-39	81777	3 Mar.	10 Apr.	27 Apr.	17	Satis.	Satis.	-
4-40	82022	22 Mar.	10 Apr.	30 Apr.	20	Right Mag. cuts out	Satis.	-
5-39	81777	-	2 May	7 May	5	Left Mag. rough but drop-off not excessive	Satis.	12 May
5-40	82022	-	2 May	7 May	5	Left and right Mags. cut out	Satis.	12 May

one part C-147 to eight parts kerosene was sprayed on the aircraft from a pressure tank. The aircraft were scrubbed with brushes dipped in buckets of Gunk solution in the manner described above and then rinsed twice. The first rinse was hot-liquid jet with C-120 detergent to remove the C-147 solution. The second rinse was a clear fresh-water hot-liquid jet (without detergent) used to rinse off the C-120 detergent solution.

5.4.4 Contamination Distribution. Detailed beta surveys were made with the NRDL RBI-12 beta survey instrument on the YAG 40 aircraft after Shots 2 and 5. Information obtained from these surveys was used to determine the contamination distribution on the aircraft. The results of this study cannot be considered representative of the condition which might be encountered on the deck of an aircraft carrier, because the location of the aircraft on the No. 5 hatch of the YAG 40 was sheltered fore and aft by the ship's structures, which resulted in different wind currents.

## 5.5 DISCUSSION AND RESULTS

Aircraft washdown and decontamination results are treated under five headings: washdown effectiveness, material damage, decontamination effectiveness and decay, comparison of decontamination methods, and contaminant distribution.

5.5.1 Washdown Effectiveness. The effectiveness of the washdown system shown in Figures 5.13 and 5.14 is based on the data recorded by fixed gamma instruments located in the cockpits of the aircraft on both ships. Only results from Shots 4 and 5 are included.

Analysis of the data after Shot 4 indicated that the ships were subjected to equivalent contaminating events. A similar study after Shot 5 indicated that there was a significant difference in the contamination received by each ship. These analyses, the contamination ratios which were developed for Shot 5, and the general aspects of the washdown study have been discussed in Chapter 2. The effectiveness values for the washdown system were determined by comparing the dose and dose-rate values recorded at Station 69 in the cockpit of the aircraft on the YAG 39 to corresponding values recorded at the same location on the aircraft from the YAG 40. Thus, the effectiveness values may be expressed as:

$$\text{Percent of effectiveness} = 100 - \frac{\text{dose or dose rate values on YAG 39}}{\text{dose or dose rate values on YAG 40}} \times 100$$

The effectiveness values for Shot 5 shown in Figure 5.14 are based on the corrected values (including contamination ratios) rather than the actual recorded data. Effectiveness values based on dose and dose-rate information are included for both Shots 4 and 5. The latest periods of time for a comparison of the effectiveness values are at 5 hr after Shot 4 and about 12 hr after Shot 5, because the basis of comparison was upset by a rainstorm at this time after Shot 4 and fallout continued after the washdown had been turned off at 12 hr after Shot 5. The



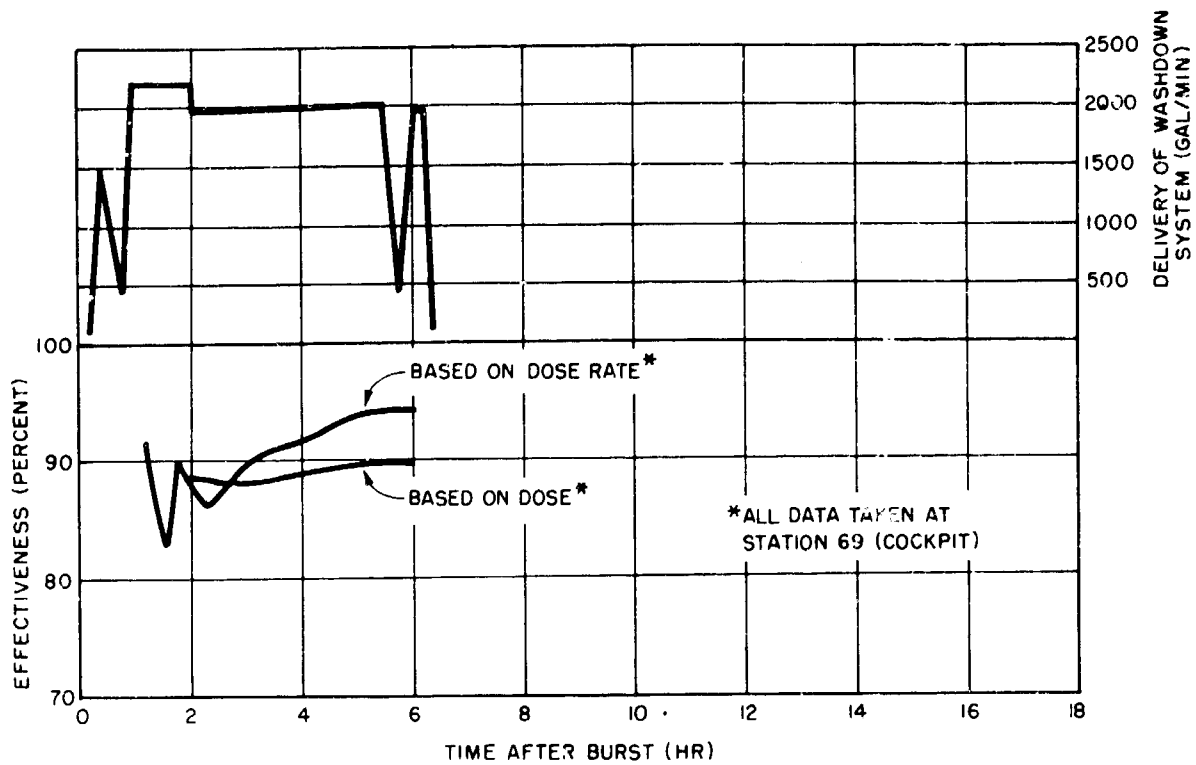

Figure 5.13 Washdown effectiveness for Shot 4.

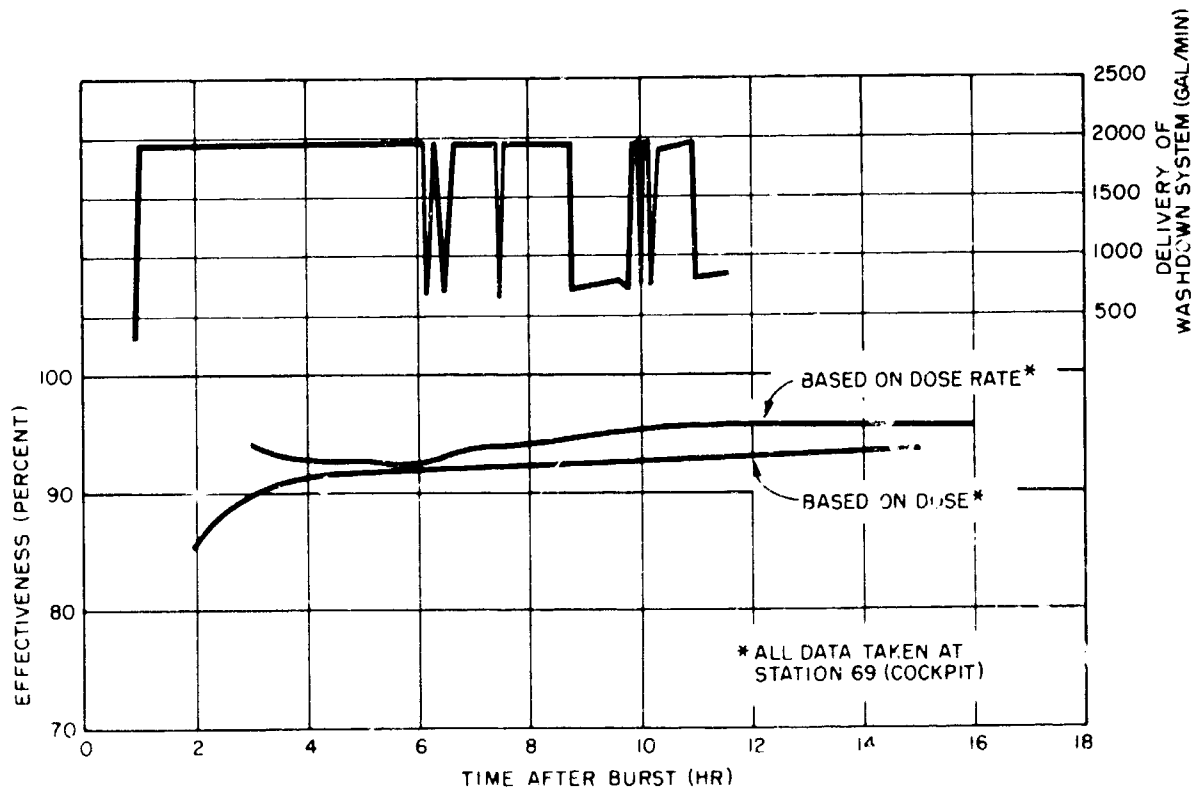

Figure 5.14 Washdown effectiveness for Shot 5.

effectiveness values based on dose rate are most significant to the aircraft studies, since it is assumed that the plane is secured and unmanned during the fallout period. After fallout has ceased, the dose-rate effectiveness value may be used to predict dosages for any subsequent period if decay rates are known. It also permits an evaluation of the washdown effectiveness in terms of reduction of dosage that will be accumulated by the pilot in flying a mission.

Complete information about the gamma-radiation intensities at early times aboard the test ships is given for Station 69 and 70 in Figures D.1 through D.13, Appendix D. Pertinent information for Shots 2, 4, and 5 are included. The washdown effectiveness for aircraft given in this chapter used the data from the cockpit station only. The radiation intensities at Station 70, which was set up to record dosage in the near vicinity of the aircraft, are of the same order of magnitude as those reported in Chapter 2.

This test was not exactly characteristic of what might be expected on a flight deck, because this was an ideal washdown system and there was a difference in ship's structure and only one aircraft was used. Furthermore, no exact method could be used to determine the extent to which radiation from the ship's structure contributes to the intensity recorded in the cockpit of the aircraft and the extent to which the radiation from the aircraft contributed to the intensity recorded at deck Station 70. However, an indication of these two contributions was obtained when the aircraft was removed from the YAG 40 at 55 hr after Shot 5. Station 70 was not removed when the aircraft was transferred to the decontamination pad and was allowed to run for a period after the aircraft was removed. As can be seen from Figure D.11, Appendix D, the radiation intensity at Station 70 was decreased by approximately 20 percent at this time. The gamma-intensity level at Station 69 at 50 hr, as shown in Figure D.10, Appendix D, was decayed to 60 hr. This level was compared to the level that was observed at the same station after the aircraft and instruments were transported to the decontamination pad, and it was noted that the intensity in the cockpit was 25 percent lower than it would have been had the aircraft remained on the ship. These data are quite interesting, because they indicate the aircraft contributed about 75 percent of the radiation to the cockpit station and only about 20 percent to Station 70. These data further demonstrate the need for a countermeasure to be employed on the aircraft before the pilot flies his mission, because the structure itself is the prime radiation contributor to the intensity level in the cockpit.

It has been shown (Reference 10) that a countermeasure such as the washdown, which gives at least 95-percent reduction based on dose rate, is required for adequate protection of the aircraft and aircraft carrier. As can be seen from Figures 5.13 and 5.14, this reduction in dose rate was achieved during Shot 5 and came very close during Shot 4. It is reasonable to expect that an even greater reduction should be expected under conditions similar to those at Operation Castle, if the washdown system is refined and the course of the ship is controlled to distribute the washdown water better.

5.5.2 Material Damage. When the aircraft were unloaded after Shot 1, they had been without maintenance for only 7 days, and both checked

out satisfactorily. However, after they were subjected to a 19-day period before Shot 2 with no maintenance, the performance of both aircraft was adversely affected. The second group of aircraft were subjected to a 17-day period on the test ships before Shot 4 and a 5-day period before Shot 5 without maintenance and showed a similar impairment of performance due especially to magneto dropoff. The only damage evident that would have grounded the aircraft after they had been subjected to the salt-water washdown and decontamination was the excessive magneto dropoff.

Table 5.2 summarizes the cockpit and radio checks and shows when the aircraft were de-preserved and re-preserved and how many days they were aboard the test ships without maintenance. The detailed material damage check sheets are given in Tables D.1 through D.8, Appendix D.

Minor items of damage noted during the inspections were excessive water where the lead goes into the spark plug and many cases of corrosion of unpainted ferrous metals. These were not considered serious, because they would be corrected during normal maintenance procedures.

These aircraft were not flown at the test site; consequently, the operation of the landing gear could not be checked.

The excessive magneto dropoff might be kept to a minimum by installing a quick-removable cover which would cover the forward part of the engine cowl and shield the front bank of cylinders from the salt water. Also, in a normal operating situation, the aircraft would be turned up as soon as possible after the salt-water washdown, which would further reduce the magneto dropoff.

5.5.3 Decontamination Effectiveness and Decay. The total time between the start and finish of the decontamination of an aircraft varied from 25 to 100 hr. Decontamination operations were performed only during normal working hours, and since part of the reduction in contamination was due to decontamination and part to decay, it was necessary to use a decay rate to calculate the amount of decay to be subtracted in determining the decontamination effectiveness. The decay factor was applied to the results of the beta surveys (used for contamination distribution studies) and gamma surveys (used for decontamination data). No decay factor was needed for the data from the fixed gamma recorder, because it gave a continuous record.

The average beta and gamma decay rate for the shots in which the aircraft participated was calculated as being approximately  $t^{-1.4}$ . This figure was used for all beta decay calculations.

In analyzing the data recorded by the fixed gamma instruments during the decontamination phase, it was apparent that the decay after each individual decontamination treatment did not resemble the usual decay patterns. An increase of radiation intensity occurred each time. An apparent stabilization then occurred; after this, the decay slope was similar to the decay observed before decontamination was begun (see Figure 5.15). This same phenomena has been observed in laboratory work in which a fission product mixture resulting from  $U^{235}$  and  $U^{238}$  irradiated at the National Reactor Testing Station was used. The time and percent increases observed in the field were similar to those observed in the laboratory work. This phenomena was attributed to the preferential

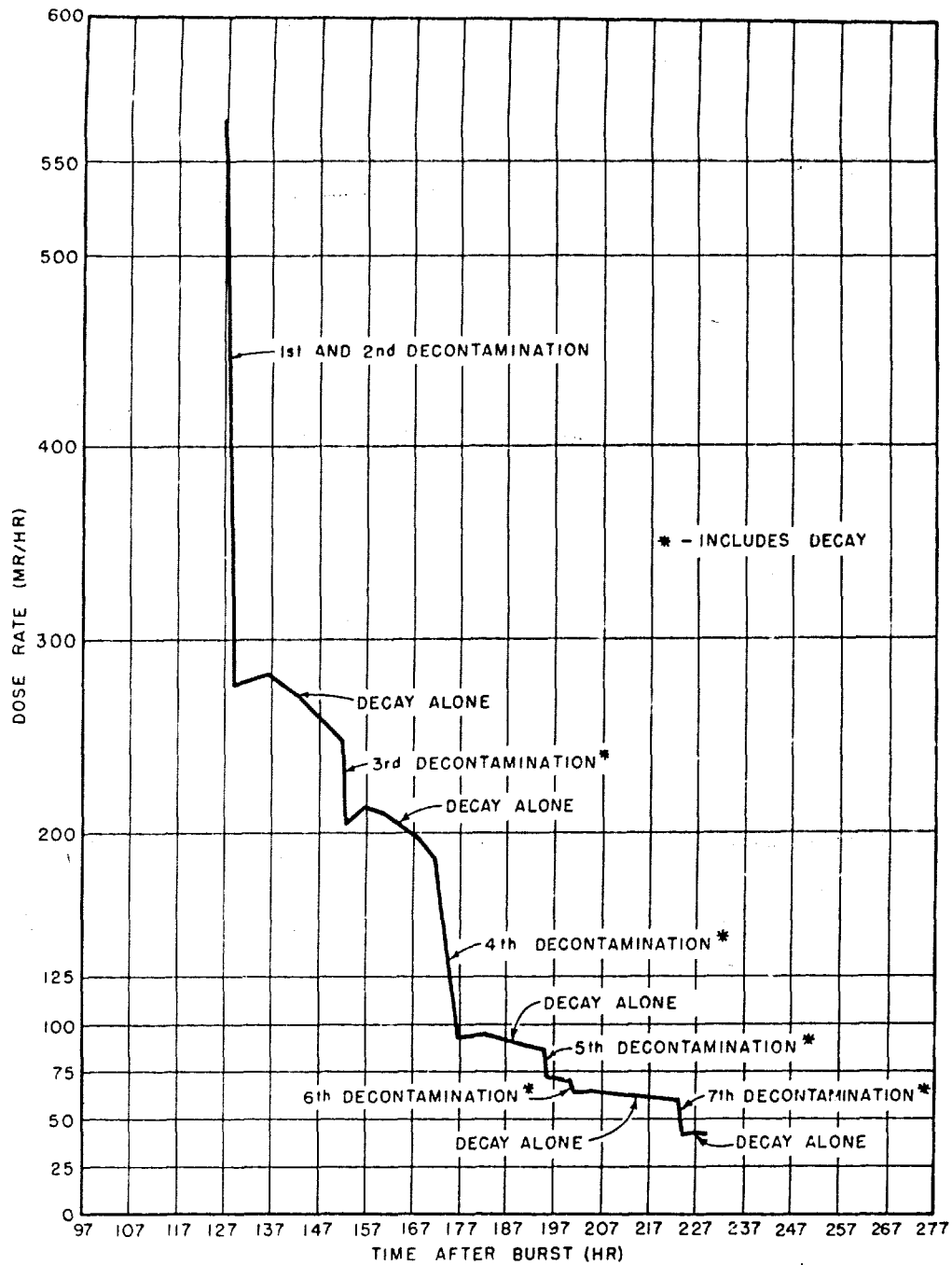

Figure 5.15 Decay at Station 69 (cockpit station) of the aircraft from the YAG 40 during the decontamination phase after Shot 2.

removal of short-life daughters by the decontamination process and the consequent disturbing of the equilibrium between the daughter and the parent. Because of these apparent deviations from the decay rate of  $t^{-1.4}$ , calculations were based on the data from the fixed gamma recorder and gamma surveys to derive decay rates applicable to these particular test operations, i.e., intermittent aircraft decontamination. These decay rates were  $t^{-0.9}$  for Shot 2,  $t^{-1.3}$  for Shot 4, and  $t^{-1.0}$  for Shot 5 and have been applied to the gamma-survey data.

To determine the percentage contributions of decay and decontamination to the reduction of the initial (or before-decontamination) radiation intensity, the fixed gamma data were analyzed to find the contribution of both decay and decontamination at each individual step. The total contribution of each reported in Tables 5.3 and 5.4 was then

TABLE 5.3 GAMMA RECORD FOR DECONTAMINATION PHASE OF THE YAG 40 AIRCRAFT AFTER SHOT 2

Numerical Order of Decontamination <sup>(a)</sup>	Contamination Level (mr/hr)	Reduction by Decay <sup>(b)</sup> (mr/hr)	Reduction by Decontamination (mr/hr)	Resulting Level (mr/hr)
1st	572	10	129	433
2nd	433	14	142	277
3rd	277	29	44	204
4th	204	23	86	95
5th	95	9	14	72
6th	72	1	7	64
7th	64	7	14	43
Total		94	436	
Per cent of original level		16.3%	76.2%	7.5% <sup>(c)</sup>

(a) Refer to Table 5.6 for a description and percent reduction effected by each decontamination process.

(b) Decay is calculated from end of one decontamination process to end of next one.

(c) Percent of original level remaining after decontamination effort.

determined. These results show that an overall reduction from decay and decontamination of 92.5 percent was achieved after Shot 2 and a reduction of 92.8 percent was achieved after Shot 5. Of these total reductions, 76.2 and 70.4 percent were effected by decontamination alone after Shots 2 and 5, respectively.

5.5.4 Comparison of Decontamination Methods. Following the contaminating events, the aircraft and test plates were received ashore in three conditions of contamination which affected the decontamination results. These were:

Condition A. After slight washing (one rainstorm), test plates and aircraft from YAG 40, after Shot 2.

Condition B. After washing by heavy rainstorms, test plates and aircraft from YAG 40, after Shots 4 and 5.

TABLE 5.4 GAMMA RECORD FOR DECONTAMINATION PHASE  
OF THE YAG 40 AIRCRAFT AFTER SHOT 5

Numerical Order of Decontamination <sup>(a)</sup>	Contamination Level (mr/hr)	Reduction by Decay <sup>(b)</sup> (mr/hr)	Reduction by Decontamination (mr/hr)	Resulting Level (mr/hr)
1st	1183	43	357	783
2nd	783	33	293	457
3rd	457	97	59	301
4th	301	53	23	225
5th	225	34	61	130
6th	130	3	17	110
7th	110	2	23	85
Total		265	833	
Pcr Cent of Original Level		22.4%	70.4%	7.2% <sup>(c)</sup>

(a) Refer to Table 5.6 for a description and percent reduction effected by each decontamination process.

(b) Decay calculated from end of one decontamination process to end of next one.

(c) Percent of original level remaining after decontamination effort.

Condition C. After washdown: aircraft from YAG 39, after Shots 4 and 5, or after prior decontamination; test plates and aircraft from YAG 40, after Shots 2, 4, and 5.

To fully evaluate the various decontamination methods, it was necessary to use the combined test-plate and aircraft-decontamination results for a comparison of the methods under these three conditions.

The fixed gamma detector gave a continuous record of the cockpit radiation intensities and provided sufficient data to give the contribution of decay and that of individual decontamination methods toward the overall reduction of the radiation field. The gamma-survey data were used as the basis for comparing the effectiveness of decontamination methods, since measurements of this type were made on both aircraft and test plates. A percentage comparison of the decontamination effectiveness determined from fixed gamma data and the aircraft gamma-survey data averaged for each aircraft on Shots 2 and 5 were in close agreement, although the ratios of intensities as determined by the two types of measurements were different on the two shots (see Figures D.30 and D.31, Appendix D).

The three conditions of contamination were based on the percentage of contaminant that had been removed by rainstorms, washdown, or decontamination. Condition A had slight or no removal of contaminant. Condition B covered the range from Condition A to an estimated 35-percent removal of contamination by rainstorms. If one takes the difference between the anticipated 45-percent removal of contaminant by firehosing from the slightly washed or unwashed aircraft and 8-percent removal by the same method from Shot 4 test plates after heavy rainstorms, there results an estimated 35-percent removal of contaminant that may be

accomplished by rainstorms several days after contamination and prior to decontamination. Condition C is subdivided into C-1, which includes the range of 35 to 60 percent of removal by prior decontamination (firehosing or hot-liquid-jet washing), and C-2, which had approximately 95-percent prior removal by washdown.

The results for decontamination of aircraft under the three conditions of contamination were based on the actual and interpolated data obtained from the decontamination of the test aircraft and test plates.

#### Condition A.

1. One firehosing removed 35 percent of the original contaminant and is capable of removing 45 percent. Two passes with a firehose removed a total of 50 percent of the initial contaminant. Results of the initial decontamination of the aircraft from the YAG 40 after Shot 2 showed that a single 6-min (20,000 sq ft/hr) firehosing removed 36 percent of the original contaminant (see Table 5.5). Since a second 24-min (5,000 sq ft/hr) firehosing with two nozzles brought the total amount removed from the same aircraft to 51 percent, it is assumed that a longer and more-thorough initial firehosing is capable of removing up to 45 percent of the original contaminant. Thus, two passes with a firehose removed a total of 50 percent of the initial contaminant from an aircraft; the amount removed by each pass depended upon the time and thoroughness of the washing on each pass.

2. One hot-liquid-jet washing is capable of removing 50 to 60 percent of the initial contaminant. A second pass will remove little additional contaminant. These figures are based on a combination of test-plate data and past experience. The results from two sets of test plates from the YAG 40 after Shot 2 showed that one hot-liquid-jet washing is 18 and 21 percent more effective than a single firehosing. Adding the average of these (19 percent) to the firehosing results for Condition A-1 gives 50 to 60 percent of removal for a single hot-liquid-jet washing. Test-plate results from Shots 4 and 5 indicate that no additional contaminant is removed by a second hot-liquid-jet washing (see Table 5.6). However, past experience indicated that some contaminant is removed by a second pass.

#### Condition B.

1. One firehosing removed 5 to 10 percent and two passes with the firehose removed a total of 10 to 15 percent of the remaining contaminant. The results from one firehosing with 20 psig water pressure on test plates after Shot 4 was 8-percent removal. This value should be slightly greater with a higher water pressure. Shot 5 test-plate data showed no contaminant was removed by the first firehosing but 18 percent was removed by the second pass. Discarding the results of the first decontamination as being unreliable, it is assumed that 10 percent of the contaminant was removed by the first pass. Thus, there results the range of 5 to 10 percent removal, which was obtained when the maximum amount of contaminant was removed by prior rainstorms. If the amount removed by prior rainstorms is less than the maximum, the percentage of contaminant removed by a single firehosing would increase. The total of 10 to 15 percent removal of remaining contaminant

TABLE 5.3 AIRCRAFT DECONTAMINATION EFFECTIVENESS RESULTS

Shot and Plane	Type of Reading	Readings Taken Before Decontamination	1st Decontamination			2nd Decontamination			3rd Decontamination			4th Decontamination		
			Decontamination Procedure	% of Contaminant Removed by this Procedure	% of Original Contaminant Remaining	Decontamination Procedure	% of Contaminant Removed by this Procedure	% of Original Contaminant Remaining	Decontamination Procedure	% of Contaminant Removed by this Procedure	% of Original Contaminant Remaining	Decontamination Procedure	% of Contaminant Removed by this Procedure	% of Original Contaminant Remaining
2 YAG 34	Beta Survey	4731	Firchase with SW at 100 lb/in <sup>2</sup>	57	43	Firchase with SW at 100 lb/in <sup>2</sup>	8	42	HLJ-SW with detergent	39*	27*	Scrub with detergent HLJ rinse	64*	4*
	Gamma Cockpit	2060		36	64		28	49		27	45		55	21
	Gamma Tail	572		24	76		34	50		19	43		48	23
4 YAG 34	After Shot (hr)	(124)	(124-126-1/2)			(126-1/2-129)			(127-154)			(173-176)		
	Beta Survey	58	Scrub with detergent HLJ rinse	57	43	Scrub with detergent HLJ rinse	32	52						
	Gamma	69		36	64		10	68						
4 YAG 40	Time After Shot (hr)	(54)	(54-57)			(77-81)								
	Beta Survey	277	HLJ-SW with detergent	29	71	Scrub with detergent HLJ-SW rinse	60	30	Scrub with detergent HLJ-SW rinse	23	22			
	Gamma	177		23	77		39	50		14	44			
5 YAG 39	Time After Shot (hr)	(123)	(123-124)			(124-128)			(125-130)			(122-129)		
	Beta Survey	217	HLJ-SW with detergent	20	80	Scrub with detergent HLJ-SW rinse	46	45	Scrub with Gunk HLJ-FW rinse	16	40	Scrub with detergent HLJ-FW rinse	28	22
	Gamma	278		18	82		17	71		42	44			
5 YAG 40	Time After Shot (hr)	(77)	(77-79)			(103-105)			(125-130)			(99-105)		
	Beta Survey	2786	HLJ-SW with detergent	37	63	Scrub with detergent HLJ-SW rinse	43	39	Scrub with detergent HLJ-SW rinse	29	28	Scrub with detergent HLJ-FW rinse	20	37
	Gamma Cockpit	1970		32	68		37	46		14	42			
5 YAG 40	Gamma Tail	1183		34	66		39	42		16	35			
	After Shot (hr)	(76)	(76-79)			(79-82)								

Per cent of original contaminant remaining is the ratio of the activity after decontamination to the original activity decayed to the time of the particular decontamination.

Per cent of contaminant removed is the ratio of activity removed to that present before the particular decontamination.

Results marked with the asterisk are of doubtful validity.

For all shots, beta decay was from the 1.4 decay curve.  
 For Shot 2, gamma decay was from the 0.9 decay curve.  
 For Shot 4, gamma decay was from the 1.3 decay curve.  
 For Shot 5, gamma decay was from the 1.0 decay curve.

HLJ means hot liquid jet; SW stands for saltwater and FW for fresh water.  
 Time after shot gives times at which the monitor readings were taken.

Average beta survey readings are given in  $\mu$  amp.

Average gamma survey readings are given in mr/hr.

Fixed gamma readings are from one instrument reading in mr/hr.



Shot and Plane	Type of Reading	Readings Taken Before Decontamination	5th Decontamination		6th Decontamination		7th Decontamination		8th Decontamination							
			Decontamination Procedure	% of Contaminant Removed by this Procedure	% of Original Contaminant Remaining	Decontamination Procedure	% of Contaminant Removed by this Procedure	% of Original Contaminant Remaining	Decontamination Procedure	% of Contaminant Removed by this Procedure	% of Original Contaminant Remaining					
2 LAG 40	Beta	4731	Scrub with detergent HLI rinse	3*	4*	(197-201)	Scrub with Gunk HLI-FW rinse	(218-221)	Scrub with Gunk HLI-FW rinse	(221-224)						
	Survey	2060	17	18	56*						2	-	-			
	Cockpit	512	16	19	11						16	29	12			
	Time After Shot (hr)	(124)			10						17	24	13			
4 LAG 39	Beta	58	(194-197)	Scrub with detergent HLI rinse	3*	(197-201)	Scrub with Gunk HLI-FW rinse	(218-221)	Scrub with Gunk HLI-FW rinse	(221-224)						
	Survey	69									17	18	56*	2	-	-
	Cockpit										16	19	11	16	29	12
	Time After Shot (hr)	(54)											10	17	24	13
2 LAG 40	Beta	277	(194-197)	Scrub with detergent HLI rinse	3*	(197-201)	Scrub with Gunk HLI-FW rinse	(218-221)	Scrub with Gunk HLI-FW rinse	(221-224)						
	Survey	177									17	18	56*	2	-	-
	Cockpit												11	16	29	12
	Time After Shot (hr)	(123)											10	17	24	13
5 LAG 39	Beta	217	(194-197)	Scrub with detergent HLI rinse	3*	(197-201)	Scrub with Gunk HLI-FW rinse	(218-221)	Scrub with Gunk HLI-FW rinse	(221-224)						
	Survey	278									17	18	56*	2	-	-
	Cockpit												11	16	29	12
	Time After Shot (hr)	(77)											10	17	24	13
5 LAG 40	Beta	2796	(194-197)	Scrub with detergent HLI rinse	3*	(197-201)	Scrub with Gunk HLI-FW rinse	(218-221)	Scrub with Gunk HLI-FW rinse	(221-224)						
	Survey	1970									35	15	52	7	-	-
	Cockpit	1183									54	17	19	14	-	-
	Time After Shot (hr)	(76)									42	18	20	16	-	-

TABLE 5.6 TEST PLATE DECONTAMINATION EFFECTIVENESS RESULTS

No. of Plate and Plate No.	Type of Reading	Initial Reading Before Decontamination	1st Decontamination			2nd Decontamination			3rd Decontamination			4th Decontamination		
			Decontamination Procedure	% of Contaminant Removed by this Procedure	% of Original Contaminant Remaining	Decontamination Procedure	% of Contaminant Removed by this Procedure	% of Original Contaminant Remaining	Decontamination Procedure	% of Contaminant Removed by this Procedure	% of Original Contaminant Remaining	Decontamination Procedure	% of Contaminant Removed by this Procedure	% of Original Contaminant Remaining
1 YAG-0	Beta Gamma	364	Firehose-SW at 90 lb/in <sup>2</sup>	35	65	Firehose-SW at 90 lb/in <sup>2</sup>	30	46	NONE. New instrument or reverse decay	-10	50			
			HLJ-SW with detergent	23	77	HLJ-SW with detergent	-1	75	Scrub with detergent HLJ-SW rinse	57	29			
2 YAG-0	Beta Gamma	157	Firehose-SW at 50 lb/in <sup>2</sup>	8	92	Firehose-SW at 20 lb/in <sup>2</sup>	1	91	Scrub with detergent HLJ-SW rinse	73	24			
			HLJ-SW with detergent	26	74	HLJ-SW with detergent	62	28	Scrub with detergent HLJ-SW rinse	7	26			
3 YAG-0	Beta Gamma	270	HLJ-SW with detergent	35	65	HLJ-SW with detergent	-4	61	Scrub with detergent HLJ-SW rinse	80	13			
			Firehose-SW at 100 lb/in <sup>2</sup>	6	94	Firehose-SW at 100 lb/in <sup>2</sup>	15	75	Scrub with detergent HLJ-SW rinse	76	18	Scrub with detergent HLJ-SW rinse	25	10
4 YAG-0	Beta Gamma	1570	Firehose-SW at 100 lb/in <sup>2</sup>	-3	103	Firehose-SW at 100 lb/in <sup>2</sup>	16	85	Scrub with detergent HLJ-SW rinse	87	10			
			HLJ-SW with detergent	10	90	HLJ-SW with detergent	95	4.3	Scrub with Gunk HLJ-FW rinse	6	4.1	Scrub with detergent HLJ-SW rinse	40	6.0
5 YAG-0	Beta Gamma	1410	HLJ-SW with detergent	14	86	Gunk HLJ-FW rinse	89	9.2		37	5.8			

Per cent of original contaminant remaining is the ratio of the activity after decontamination to the original activity decayed to the time of the particular decontamination.

Per cent of contaminant removed is the ratio of activity removed to that present before the particular decontamination.

HLJ means hot liquid jet; SW stands for saltwater and FW for fresh water. Beta readings are given in  $\mu$  amp; gamma readings are given in mr/hr.

with two firehosings is based on the results of Shot 4 and Shot 5 test plates, which gave 12 and 15 percent removal of contaminant under these conditions.

2. One hot-liquid-jet washing removed 20 to 30 percent of the remaining contaminant; a second pass will remove little additional contaminant. The first hot-liquid-jet washing of the aircraft from the YAG 40 after Shots 4 and 5 removed 23 and 32 percent, respectively, of the remaining contaminant. In addition, the results on three out of four sets of test plates from Shots 4 and 5 came within these limits; the other set of test plates had 14 percent removal. As in the case of firehosing for this condition, these values represent the conditions after an estimated 35 percent prior removal by rainstorm. If a lesser percentage of the original contaminant is removed by the rainstorms, the percentage of the remaining contaminant removed by hot-liquid-jet washing will increase. Data from the Shots 4 and 5 test plates show no additional contaminant was removed by a second pass with the jet.

#### Condition C-1.

1. One scrubbing with detergent removed 35 percent and is capable of removing up to 75 percent of the remaining contaminant. Decontamination data from the aircraft on the YAG 40 after Shots 4 and 5 show that scrubbing with detergent after one hot-liquid-jet washing removed 39 and 37 percent of the remaining contaminant. Comparable data on test plates that had one or two jet washings, or two firehosings, before scrubbing with detergent, showed 50, 50, 76, 54, and 75 percent of the remaining contaminant removed. The test panels were decontaminated under optimum conditions; i.e., flat, clean, unweathered surfaces which were easy to scrub. The aircraft surfaces had varied shapes and accessibilities including the underside of the aircraft and the wing roots. For this reason, better scrubbing and drainage probably occurred on the test plates than on the aircraft surfaces. This may account for the fact that in all cases the test panels had a higher percentage removal than the aircraft.

2. A second scrubbing with detergent removed 10 to 50 percent of the remaining contaminant. The same two aircraft mentioned in the preceding section were given a second scrubbing with detergent, which resulted in 14-percent removal of contaminant from both aircraft. A second scrubbing of comparable test plates resulted in a 0, 21, and 52 percent removal of remaining contaminant. The 0-percent removal is considered unreliable, because of the aircraft data and past experience indicate that some contaminant will be removed by additional scrubbing.

3. One scrubbing with Gunk (C-147) removed 50 percent and is capable of removing up to 85 percent of the remaining contaminant. The Shot 5, YAG 40 aircraft, which had been washed with a hot-liquid-jet and scrubbed three times with detergent, was then scrubbed with Gunk, and 54 percent of the remaining contaminant was removed. The maximum of 85-percent removal was obtained by scrubbing test plates from Shot 5 with Gunk after only one washing with a hot-liquid jet. The Shot 2, YAG 40, aircraft had a 29-percent removal of contaminant by scrubbing with Gunk; but these data were not used, because this was the seventh decontamination of this aircraft and 84 percent of the original contaminant had been removed by the prior decontamination and decay. As

mentioned before, the effectiveness of this method of decontamination will vary inversely with the effectiveness of prior decontamination efforts or rainstorms.

4. A second scrubbing with Gunk removed 15 percent and is capable of removing up to 35 percent of the remaining contaminant. A second scrubbing of the aircraft from the YAG 40 after Shots 2 and 5 resulted in a 17 and 19 percent reduction in contaminant, respectively. Since these results were obtained on the eighth and sixth decontaminations, respectively, the actual decontamination efficiency obtainable by this method at earlier times in the decontamination operation is probably closer to the 37-percent removal obtained by the second scrubbing of the test plates from Shot 5 with Gunk.

Condition C-2.

1. The data for this condition is obtained from the decontamination of the aircraft from the YAG 39 after Shots 4 and 5. The aircraft on the YAG 39 after Shot 5 was first washed with a hot-liquid jet, which removed 18 percent of the remaining contaminant. This was followed by scrubbing with detergent, which removed an additional 17 percent, and scrubbing with Gunk, which removed 40 percent of the remaining contaminant.

2. The aircraft on the YAG 39 after Shot 4 was scrubbed twice with detergent. The first scrubbing removed 36 percent, and the second scrubbing removed 10 percent of the remaining contaminant.

A summary of the above results are given in Tables 5.7 through 5.10. They are based on the combined aircraft and test-plate results and represent the range of decontamination results. The maximum decontamination effectiveness was obtained on the test plates and represents the maximum effectiveness that can be approached under optimum conditions.

TABLE 5.7 DECONTAMINATION EFFECTIVENESS UNDER CONDITION A

Condition A - After slight prior washing or no prior washing		
Methods	Percent contaminant removed by decontamination	
	1 pass	2 passes
Firehosing	35 - 45 → 50	
Hot liquid jet with detergent	50 - 60	-

Each block includes the results of a sequence of decontamination methods which were performed in the order indicated by the arrows.

Although these percentages include the maximum percentage removal that can be approached by decontamination, it is conceded that the practical "working percentages" that will be obtained during full-scale decontamination operations will cover a much-smaller range. Tables 5.11 through 5.13 give the anticipated working percentages that can be obtained, based mainly on the aircraft test data supplemented by the

TABLE 5.8 DECONTAMINATION EFFECTIVENESS UNDER CONDITION B

Condition B - After washing by heavy rainstorms with up to 35 percent of the initial contaminant removed.				
Percent of remaining contaminant removed by decontamination				
Methods	1st pass	2nd pass	1st pass	2nd pass
Firehosing	(a) 5 - 10 → 10 - 15			
Hot liquid jet with detergent				
Scrub with detergent				
Scrub with Gunk				

(a) Percent contaminant removed by two passes; all other results are percent of remaining contaminant removed by each pass.

Each block includes the results of a sequence of decontamination methods which were performed in the order indicated by the arrows.

TABLE 5.9 DECONTAMINATION EFFECTIVENESS UNDER CONDITION C-1

Condition C-1 - After prior decontamination by firehosing or hot-liquid-jet washing which has removed from 35 to 60 percent of the original contaminant				
Percent of remaining contaminant removed by decontamination				
Methods	1st pass	2nd pass	1st pass	2nd pass
Scrub with detergent				
Scrub with Gunk				

Each block includes the results of a sequence of decontamination methods which were performed in the order indicated by the arrows.

TABLE 5.10 DECONTAMINATION EFFECTIVENESS UNDER CONDITION C-2

Condition C-2 - After prior washdown with approximately 95 percent removal of original contaminant by washdown				
Percent of remaining contaminant removed by decontamination				
Methods	1st pass	2nd pass	1st pass	2nd pass
Hot liquid jet with detergent	18	-		
Scrub with detergent	17	-	36 → 10	
Scrub with Gunk	40	-		

Each block includes the results of a sequence of decontamination methods which were performed in the order indicated by the arrows.

TABLE 5.11 DECONTAMINATION WORKING PERCENTAGES UNDER  
CONDITION B, BASED MAINLY ON AIRCRAFT DATA

Condition B - After washing by heavy rainstorms with up to 35 percent of the initial contaminant removed

Percent of remaining contaminant removed by decontamination

Methods	1 pass	2 passes	1 pass	2 passes
Firehosing	5 - 10 → 10 - 15			
Hot liquid jet with detergent	20	30	-	-
Scrub with detergent	35 - 40	45 - 50	-	-
Scrub with Gunk	-	-	50 - 60	60 - 70

Each block includes the results of a sequence of decontamination methods which were performed in the order indicated by the arrows.

TABLE 5.12 DECONTAMINATION WORKING PERCENTAGES UNDER  
CONDITION C-1, BASED MAINLY ON AIRCRAFT DATA

Condition C-1 - After prior decontamination by firehosing or hot-liquid-jet washing which has removed from 25 to 60 percent of the original contaminant

Percent of remaining contaminant removed by decontamination

Methods	1 pass	2 passes	1 pass	2 passes
Scrub with detergent	35 - 40	45 - 50	-	-
Scrub with Gunk	-	-	50 - 60	60 - 70

Each block includes the results of a sequence of decontamination methods which were performed in the order indicated by the arrows.

TABLE 5.13 DECONTAMINATION WORKING PERCENTAGES UNDER  
CONDITION C-2, BASED MAINLY ON AIRCRAFT DATA

Condition C-2 - After prior washdown with approximately 95 percent removal of original contaminant by washdown

Percent of remaining contaminant removed by decontamination

Methods	1 pass	2 passes	1 pass	2 passes
Hot-liquid jet with detergent	15 - 20	-	-	-
Scrub with detergent	15 - 20	-	35 - 40	40 - 45
Scrub with Gunk	40 - 50	-	-	-

Each block includes the results of a sequence of decontamination methods which were performed in the order indicated by the arrows.

test plate data and past experience. Table 5.7 also applies as working percentages. The values for firehosing and washing with the hot-liquid jet are quite reliable since considerable data have been accumulated for these conditions. The values for an initial scrubbing with detergent or Gunk are the conservative, since no test data were obtained for these conditions, except on the Shot 5, YAG 39, aircraft after washdown. All the other data for scrubbing were on surfaces that had received one or more prior decontaminations by combinations of firehosing, washing with the hot-liquid jet, or scrubbing with detergent; these data have been used as the basis for the values in this table. The percentage removal in Tables 5.11 through 5.13 are given on the basis of one pass and two passes in order to limit the range to realistic values. The values for two passes are obtained by multiplying the percent remaining after one pass by the percent removed by the second pass, adding this product to the percent removed by one pass, and adjusting the sum to a workable percentage on the basis of other test data and past experience.

Graphs of the decontamination results are given in Figure 5.16 through 5.19. Figure 5.16 compares the results of the aircraft decontaminations on the basis of the initial contaminant that did or would have landed on the aircraft by compensating for the prior removal of contaminant for Conditions B and C-2. Figures 5.17 through 5.19 show the results for the individual conditions based on the percent of the as-received contaminant remaining after the various decontaminations. When comparable test panel results are applicable, they are given at the top of the figure for comparison.

5.5.4.1 Discussion. When an aircraft is received in Condition A or Condition C-2, decontamination results should be consistent with those reported here.

When an aircraft is received under Condition B or Condition C-1, the effectiveness of any subsequent decontamination will vary inversely with the amount of prior removal. Thus, if prior removal approaches the maximum as given for Condition B or C-1, a low effectiveness may be expected for the first subsequent decontamination, if firehosing or hot-liquid-jet-washing methods are used.

Figure 5.16 demonstrates the efficiency of the washdown system. It shows that, on a comparative basis, the percentage remaining on all the YAG 40 aircraft after complete decontamination was more than that on the YAG 39 (washdown) aircraft before decontamination was begun.

A comparison of the test plate results and the aircraft results, Figures 5.17 and 5.18, shows that firehosing results are in close agreement and hot-liquid-jet washing results in fairly close agreement. However, the results from scrubbing with detergent and scrubbing with Gunk show that, in all cases, more-effective decontamination was obtained on the test plates than on the aircraft.

This discrepancy can be attributed to the flat surface and the accessibility of the test plates decontaminated under ideal conditions, as contrasted to the aircraft with its many configurations, openings, and joints decontaminated under test conditions. Further proof can be found in Table D.11, Appendix D, which compares the average of the gamma-survey-meter readings with location 40 readings. The average reduction from the first scrubbing with detergent (the fourth decontami-

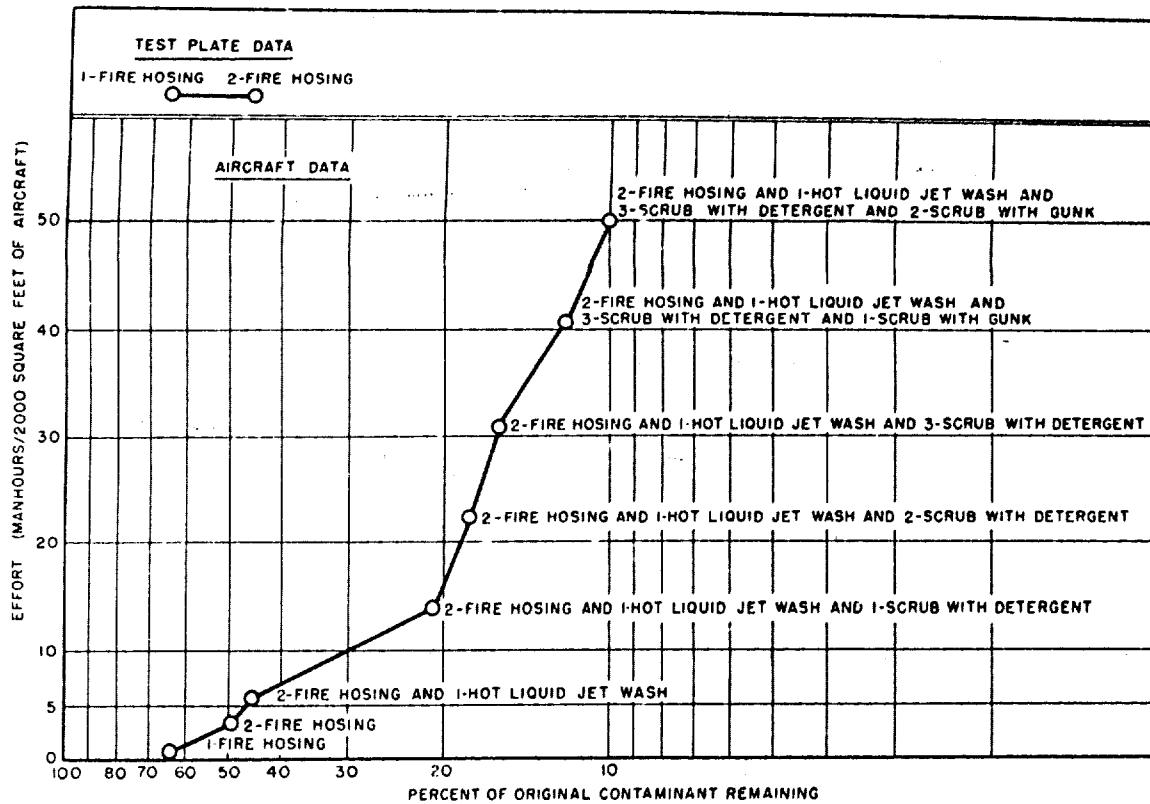

Figure 5.16 Percent of original contaminant remaining versus manpower.

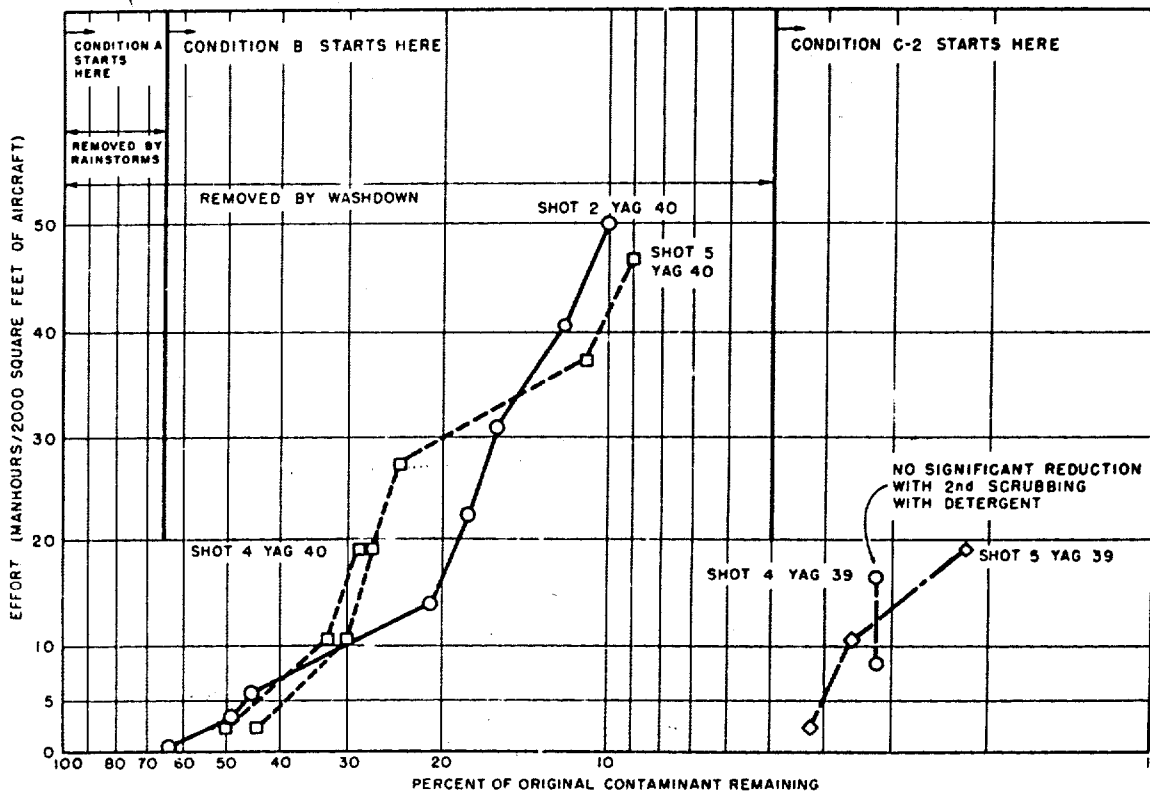

Figure 5.17 Percent of original contaminant remaining versus manpower for Condition A, Shot 2 YAG 40.



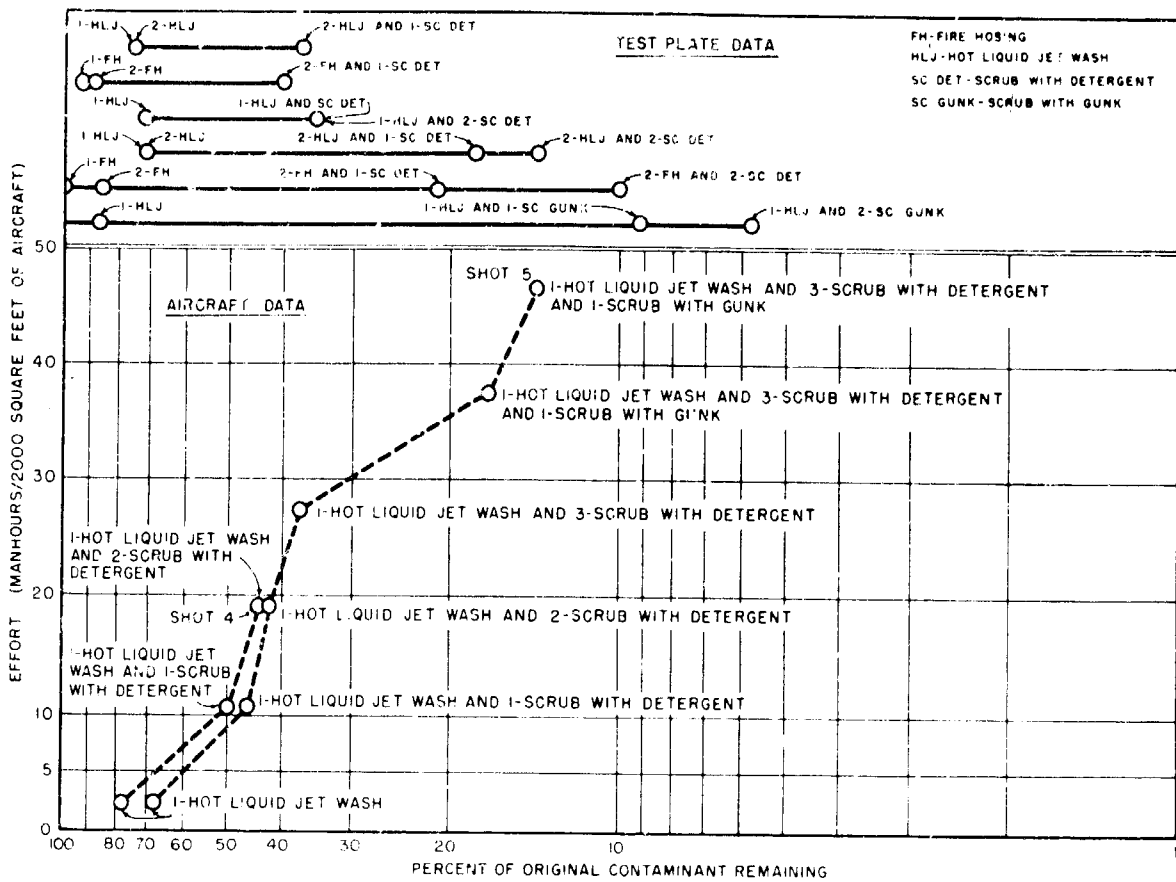

Figure 5.18 Percent of original contaminant remaining versus manpower for Condition B, Shots 4 and 5 YAG 40.

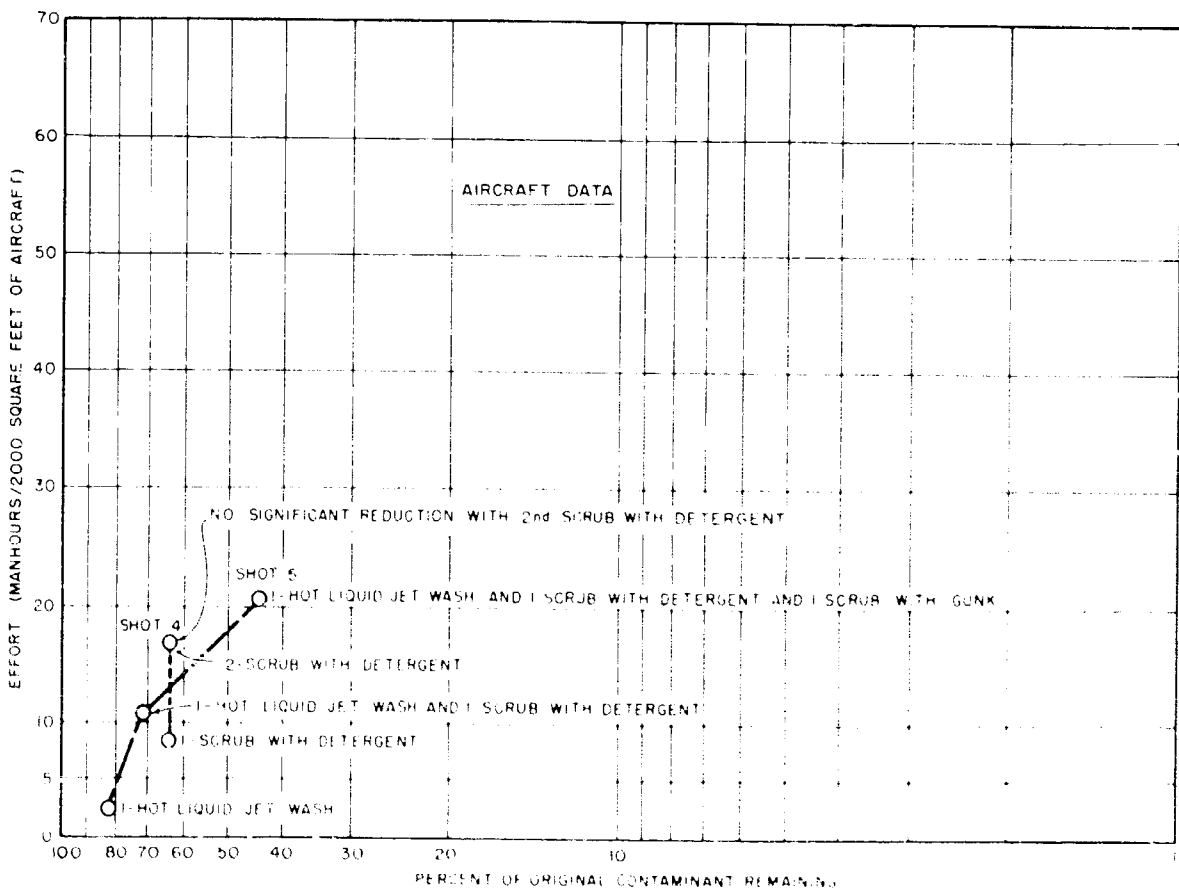

Figure 5.19 Percent of original contaminant remaining versus manpower for Condition C-2, Shots 4 and 5 YAG 39

nation) was 55 percent from the average survey-meter readings, compared to 82 percent at Location 40. This indicates that, at some locations on the aircraft, the ideal conditions of the test plates are duplicated and, at these locations, the aircraft-decontamination effectiveness approaches that obtained on the test plates but that data from all surfaces are needed to predict the decontamination effectiveness of an aircraft by scrubbing methods.

The results of the initial firehosing indicates that two passes will remove a total of 50 percent of the contaminant. The amount removed by the second firehosing will depend upon the amount removed by the first pass and will bring the total contaminant removed up to 50 percent of the original contaminant.

The results from the test plates for Shots 4 and 5 show that the hot-liquid-jet washing with fresh or salt water have about the same decontamination effectiveness. The jet washing was always performed with detergent. The scrubbing with detergent or Gunk on the aircraft and test plates was always followed by a jet rinse, with one exception. On this occasion, a firehose was used to rinse the test plates. The data from the one use of scrubbing with detergent followed by a firehose rinse indicate that the type of rinse did not affect the decontamination effectiveness.

Since the decontamination of the aircraft included industrial as well as tactical decontamination methods, data were obtained for scrubbing with Gunk. However, for tactical decontamination aboard an aircraft carrier, Gunk is not recommended, because of fire hazard, slickness of the deck when Gunk is on it, and the rapid deterioration of a wood deck exposed to Gunk.

No decontamination was performed on the test plates from the YAG 39 (or washdown) ship because of insufficient contamination. The Shot 2 plates were not contaminated, because the ship did not receive significant amounts of fallout and the plates on the ship during Shots 4 and 5 did not have enough residual contaminant after washdown (less than 5 mr/hr for Shot 4 and 30 mr/hr for Shot 5) to justify decontamination.

A comparison of the results shows that one initial hot-liquid-jet washing is 5 to 15 percent more effective than one firehosing and 0 to 10 percent more effective than two firehosings.

A comparison of the hot-liquid-jet washing versus scrubbing with detergent under Condition B shows that scrubbing with detergent is the more effective, since it removed 38 percent of the remaining contaminant after two washings with the hot-liquid jet.

Scrubbing with Gunk is more effective than scrubbing with detergent. Under Condition C-1, scrubbing with Gunk removed 54 percent of the remaining contaminant after two scrubbings with detergent.

The results under Condition C-2 (washdown) indicate that a first scrubbing with detergent will remove 36 percent of the remaining contaminant but that scrubbing with Gunk is more effective, since it removed 40 percent of the remaining contaminant after one jet washing and one scrubbing with detergent.

A comparison of the results obtained under Conditions C-1 and C-2 shows that the decontamination effectiveness results are less after a washdown than after prior decontamination. Since the results are somewhat similar and the same methods of decontamination are used on both,

Conditions C-1 and C-2 are combined later in this report for recommending methods of decontamination for the three conditions.

An examination of the aircraft data shows that a second pass with any of the methods of decontamination used is relatively ineffective but the effectiveness of the second pass will vary inversely with the percentage of contaminant removed by the first pass. An examination of the test-plate data indicates that up to a maximum of 50 percent of the remaining contaminant can be removed by a second pass. This maximum was obtained by scrubbing with detergent. Other methods gave less removal for a second pass. Thus, it is again emphasized that two passes will remove a fairly constant amount and the thoroughness and effectiveness of the first pass will control how much can be removed by a second pass.

In general, the results show that scrubbing with Gunk is the most-effective method of decontamination, followed in decreasing effectiveness by scrubbing with detergent and with the hot-liquid-jet washing slightly more effective than firehosing.

The above results are based solely on decontamination effectiveness. For an overall evaluation of the various methods, the time and manpower requirements must also be taken into consideration.

A summary of the results of the time and manpower studies are shown in Table 5.14. The complete results are given in Table D.12, Appendix D. Table 5.15 gives the decontamination time, the number of men, and the manhours that would normally be necessary to accomplish the working percentage removals given in Table 5.7 and Tables 5.11 through 5.13. These results are based on the decontamination of Navy F4U aircraft, which have a surface area of approximately 2000 sq ft. During these studies, the wing tips were in the vertical position. It should also be remembered that the decontamination covered all the surfaces, which included not only the fuselage and top wing surfaces but also many configurations, such as the underside of the plane, the landing gear and the wing roots.

The rates of decontamination are calculated on the basis of the average of the total times used during actual aircraft decontamination operations. On this basis, the scrubbing with detergent was accomplished at about the same rate as is considered optimum for exterior wall surfaces from the San Bruno Test (Reference 11). The optimum rate for scrubbing with detergent was 1330 sq ft/hr versus the average rate of 1450 sq ft/hr used on the aircraft. The average rate for scrubbing was compared on the basis of the single scrub since the data indicate that the double scrub is no more effective. The average rates for firehosing and washing with the hot-liquid jet were both about 40 percent more than the rates recommended on the basis of the San Bruno Test.

Firehosing was performed at an average rate of 8300 sq ft/hr per nozzle versus 6000 sq ft/hr recommended. However, this is a poor comparison, because of the first firehosing of Shot 2, YAG 40, aircraft was accomplished with a single nozzle at 20,000 sq ft/hr with the removal of 36 percent of the original contaminant. A second firehosing of the same plane with two nozzles at a rate of 2500 sq ft/hr per nozzle removed 28 percent of the remaining contaminant. This would indicate that the rate of the first firehosing was too high to obtain maximum removal and the rate of the second firehosing was too low for maximum efficiency. Based on this test and past experience, the recommended

TABLE 5.14 SUMMARY OF TIME AND MANPOWER STUDIES OF DECONTAMINATION

	Average % of contamination removed by this decontamination process						Average rate of decontamination sq ft/hr
	Average of gamma survey meter readings	Fixed gamma cockpit readings	Average elapsed time for this decontamination process	Average total time for this decontamination process	Average No. of men used	Average total manhours used for decontamination process	Based on total decontamination time <sup>(b)</sup>
Fire-hosing	32	29	20 min <sup>(a)</sup>	24 min <sup>(a)</sup>	4 <sup>(a)</sup>	1.6 <sup>(a)</sup>	6000 <sup>(a)</sup>
Hot Liquid Jet	27	27	26 min-18 sec	36 min	4	2.4	3350
Single Scrub with Detergent	27	-	52 min-30 sec	82 min-30 sec	7.5	10.3	1450
Double Scrub with Detergent	24	21	82 min-10 sec	120 min	7.25	14.5	∞

(a) Estimated for comparison.

(b) Does not include setup time.

TABLE 5.15 TIME AND MANPOWER NECESSARY FOR DECONTAMINATION EFFECTIVENESS VALUES

Method of Decontamination	Per cent contaminant removed		Total Decop. Time <sup>(a)</sup> (hr)	No. men used	Manhours per decon.	Rate of Decontamination sq ft/hr
	1 pass	2 passes				
Firehosing	36 35-45	Condition A	0.1	4	0.4	20,000
			0.4		1.6	6,000
	45-50	0.8	3.2			
Hot liquid jet	50-60		0.6	4	2.4	3,350
Firehosing	5-10	Condition B	0.4	4	1.6	6,000
			0.8		3.2	
	10-15	0.6	2.4			
Hot liquid jet	20-30		0.6	4	2.4	3,350
Scrub with detergent	35-40	45-50	1.4	6	8.4	1,450
			2.8	6	16.8	
Scrub with Gunk	50-60	60-70	1.6	6	9.6	1,250
			3.2	6	19.2	
Scrub with detergent	35-40	Condition C-1	1.4	6	8.4	1,450
			2.8		6	
	45-50	1.6	6	9.6		
Scrub with Gunk	50-60	60-70	1.6	6	9.6	1,250
			3.2		6	
Hot liquid jet	15-20	Condition C-2	0.6	4	2.4	3,350
			1.4		6	
	35-40	2.8	6	16.8		
Scrub with detergent	40-45	40-45	2.8	6	16.8	1,450
			1.6		6	
Scrub with Gunk	40-50		1.6	6	9.6	1,250
			3.2		6	

(a) Does not include setup time.

rate of 6000 sq ft/hr appears to be low and a rate of about 8000 sq ft/hr, or 15 min per aircraft, would be better

The hot-liquid-jet decontamination was performed at an average rate of 3350 sq ft/hr, which is about 40 percent more than the 2400 sq ft/hr recommended on the basis of the San Bruno Test data. The data in Table D.12, Appendix D, indicate that a slower rate should have been more effective. The decontamination of the Shot 5, YAG 40, aircraft with the jet washing at 3000 sq ft/hr removed 32 percent of the initial contaminant, while the same method on the Shot 4, YAG 40, aircraft at 4000 sq ft/hr removed only 23 percent of the initial contaminant. The data from the test plates show a second jet washing to be ineffective.

A comparison of the time and man-hours involved show that firehosing, based on a rate of 6000 sq ft/hr, is the most efficient taking about two-thirds the time with three-fourths as many man-hours per aircraft as the hot-liquid-jet washing. However, on comparative initial decontamination efforts, the jet should be about 15 percent more effective. The single scrubbing with detergent takes about two to four times as long to go over an aircraft, while using four to five times as many man-hours and with 1 1/2 times the personnel as the hot liquid jet or firehosing.

Although no manpower data were taken on scrubbing with Gunk, it should take a slightly longer time with the same manpower as scrubbing with detergent, because an extra detergent rinse is necessary to remove the Gunk.

Figures 5.16 through 5.19 compare the percent of original contaminant remaining after decontamination methods used on the aircraft versus the effort in man-hours which would normally be used to accomplish the decontamination. Figure 5.16 has the 100-percent-remaining (initial-starting) line adjusted to compensate for the rainstorms and washdown of Conditions B and C-2. A comparison of Shots 2 and 5, YAG 40, data indicates that approximately the same number of man-hours were expended to achieve the same decontamination end point. An examination of the Shot 5, YAG 39, data shows that although the amount of contaminant removed was small, compared to the initial contaminant on the YAG 40 aircraft, nearly half of the contaminant remaining after washdown was removed by three decontaminations.

Figures 5.16 through 5.19 indicate that the first decontamination by a method is generally quite effective but that the second and third decontaminations by the same method are less efficient, considering the decreasing effectiveness on each method and the man-hours involved. This is further pointed out in the overall decontamination, which shows that the first decontamination removes a fairly large amount of the contaminant with relatively small effort but that, as the decontamination progresses, it takes a considerable effort to remove a small amount of contaminant.

The information obtained from the decontamination effectiveness results and the time and manpower studies can be applied to carrier aircraft. Tentative recommendations presented subsequently are based only on the decontamination of the aircraft exclusive of the surrounding areas. Other factors to be taken into consideration have been described in more detail in Reference 9. However, one of the most important factors to be remembered is that the flight deck and aircraft will be decontaminated simultaneously, so the method selected for the initial decontami-

nation of the flight deck will undoubtedly be used for the initial decontamination of the aircraft.

Reference 9 divided decontamination periods into "tactical" and "industrial" and further subdivided "tactical" into "emergency" and "operational." The emergency-decontamination period included the time from atomic attack until the commencement of flight operations. The operational-decontamination period was the remainder of the tactical situation. Industrial decontamination consisted of measures which had to be instituted upon delivery of tactically decontaminated aircraft to a land base for major repair of maintenance.

Although this breakdown is based entirely on an operational or time basis, tentative recommendations are made to tie in decontamination operations with this breakdown.

Table 5.16 gives data on the wipe samples taken before and during the decontamination of the aircraft from the YAG 40 after Shot 2. This table shows that the first two decontaminations (two firehosings) removed over 90 percent of the removable contaminant and that six decontaminations removed over 99 percent of the removable contaminant. These data were further verified by using a beta-survey instrument to check the gloves used by a worker who removed the engine cowling after the sixth decontamination. The reading on the instrument showed an increase of

TABLE 5.16 WIPE SAMPLE DATA, AIRCRAFT FROM THE YAG 40 AFTER SHOT 2

Sample Number	Location	Initial Wipes in d/m	Wipes After Decon. No.2 d/m	Wipes After Decon. No.6 d/m	Percentage of Original Contaminant Removed (per cent)
1	Propellor Blade-Forward	$2.33 \times 10^8$	$1.24 \times 10^7$	$8.3 \times 10^5$	99.6
10	Lower-Exterior Wing-Starboard	$3.33 \times 10^8$	$1.8 \times 10^7$	$4.45 \times 10^5$	99.85
11	Lower Exterior Wing-Starboard	$4.22 \times 10^8$	$3.24 \times 10^7$	$1.39 \times 10^5$	99.95
14	Stub Wing-Starboard	$1.24 \times 10^7$	$5.5 \times 10^5$	$4.8 \times 10^4$	99.6
15	Upper Interior Wing-Starboard	$5.77 \times 10^6$	$6.6 \times 10^5$	$1.9 \times 10^4$	99.6
20	Fuselage Near Canopy-Starboard	$4.66 \times 10^6$	$4.4 \times 10^5$	$8.2 \times 10^3$	99.8
37	Stub Wing-Port	$3.99 \times 10^6$	$8.9 \times 10^5$	$4.1 \times 10^4$	99.0
47	Lower Exterior Wing-Port	$5.77 \times 10^6$	$4.4 \times 10^5$	$1.74 \times 10^4$	99.7

Notes:

1. All readings corrected for decay.
2. Decon. No. 2 was 2nd salt water wash (firehosing).
3. Decon. No. 5 was 3rd scrubbing.
4. Refer to Figure E-37, Appendix E, for specific sample locations.

less than one scale division, which is approximately 1  $\mu\text{c}$  or  $2.22 \times 10^6$  d/m.

Dosimeters were worn by personnel assigned to the decontamination crews. Although the dosimeter readings did not always check with the film-badge readings, the data obtained from them gave some indication of the dose that was received while the individual was performing the specific decontamination job.

Table 5.17 contains the most reliable data obtained during the decontamination of the aircraft from the YAG 40 after Shot 2. These

TABLE 5.17 DOSES TO DECONTAMINATION CREWS WORKING ON AIRCRAFT FROM THE YAG 40 AFTER SHOT 2

Type of Operation	Job of Wearer	Working Time (min)	Dose (mr)	Decon. No.	Average Gamma Survey Reading Before Decontamination	Average Gamma Reading After Decontamination
Firehosing	Nozzleman	6	150	1	2060	1330
Hot Liquid Jet Washing	Nozzleman	20	50	3	1040	770
Scrub with Detergent	Scrubber	90	300	5	289	240
Scrub with Detergent	Roseman	90	100	5	289	240
Gamma Survey	Monitor	45	100	5	289	240

data illustrate the importance of using methods for the first decontamination processes which can be accomplished quickly and require the minimum number of personnel near the contaminated object. Table 5.15 gives the number of personnel employed to accomplish each decontamination method.

5.5.5 Contamination Distribution. Only the aircraft on the YAG 40 during Shots 2 and 5 were contaminated sufficiently to warrant a contaminant distribution study. The detailed surveys are given in Tables D.15 through D.17, Appendix D.

The aircraft installed on the YAG 40 during Shot 2 had patches of a white chalky substance at various locations on the windward surfaces. The decontamination effectiveness was quite high in this area, which indicated that this chalky substance was easily removable and contained most of the contamination found there. This was especially evident at Location 40 on the inboard surface of the port wing section in the vertical position. These windward surfaces were contaminated five to seven times greater than the leeward ones. In comparing readings from the vertical and horizontal surfaces on the windward side, it was found that the contamination on the vertical surfaces exceeded that on the horizontal by a factor of 1.5. The contamination on the vertical and horizontal surfaces on the leeward was approximately the same. Readings were taken on the horizontal and vertical stabilizers for some indication of the contamination distribution on topside and

underside surfaces. The ratio of the contamination of topside to underside surfaces was 9 to 1 for the windward side and 3 to 1 for the leeward.

The contamination on the aircraft installed aboard the YAG 40 after Shot 5 was more evenly distributed than that on the aircraft after Shot 2. There was no visible foreign matter evident when the aircraft was received at the decontamination site. Comparing readings (at the same locations) on the port and starboard side of the aircraft showed that the average distribution was approximately the same for both sides. Similarly, there was little difference between the average distribution on horizontal and vertical surfaces. The ratio of contamination on the topside to the underside of the horizontal stabilizer was approximately 5 to 1 for the starboard side and 2.5 to 1 for the port side.

Differences in the contamination distribution found on the two aircraft can be attributed largely to the wind and weather conditions and type of contaminant. The surface wind after Shot 2 was coming from the forward quarter on the starboard side, as was evident from the contamination distribution found on the windward and leeward surfaces. On the other hand, the surface wind after Shot 5 was approximately either parallel to the ship or from the forward quarter just a few degrees off the port bow. This fact explains the similar distribution that was found on the port and starboard side. The chalky substance found on the aircraft after Shot 2 was definitely in patches and appeared to have little runoff from them. It was almost like a thin paste which had dried on the surface. Other areas where the distribution was much lower had no such visible deposit. On the other hand, no such contaminated foreign matter was visible on the aircraft after Shot 5, and no area appeared much more heavily contaminated than others. Some of this difference between the contamination distribution was probably caused by rain, because the aircraft after Shot 5 was subjected to more severe rains than the one after Shot 2.

## 5.6 CONCLUSIONS

Under conditions similar to those during Operation Castle, it may be concluded that:

1. A washdown system which gives adequate water coverage will reduce the gamma radiation intensity level by approximately 95 percent.
2. The major contributor of radiation intensity to the cockpit of an aircraft on the deck of a ship is the contaminant on the surfaces of the aircraft itself (75 percent in the one case where data were available).
3. Contamination distribution on the aircraft will not be uniform and will depend to a great extent on the course and speed of the ship, the direction and velocity of the wind, and the type of contaminant.
4. Aircraft material damage from the washdown system will not be serious, and the aircraft will be in flight condition if the ignition system is protected.
5. On an aircraft that has not been subjected to washdown during fallout or rainstorms before decontamination, the amount of contamination can be reduced up to 50 or 60 percent by firehosing or hot-liquid-



jet cleaning. If either method is followed by one scrubbing with a detergent (C-120) or a solvent emulsion cleaner (C-147), as much as 75 or 90 percent of the original contaminant can be removed. Rainstorms before the initial decontamination will lower these percentages.

6. On an aircraft that has been subjected to washdown during fallout, the amount of contamination can be reduced up to 35 percent by scrubbing with detergent and 50 percent or more by scrubbing with a solvent emulsion cleaner.

7. On aircraft that have not been subjected to rainstorms before decontamination, the maximum efficiency, considering decontamination effectiveness time and manpower, is obtained by using one firehose or hot-liquid-jet washing, followed by a thorough scrubbing with detergent or Gunk solution.

8. A more complete decontamination can be effected by continued scrubbing with detergent or Gunk, but the additional percentage removed each time is small.

## 5.7 RECOMMENDATIONS

It is recommended that:

1. Further study be done on the effectiveness of the washdown system on stacked aircraft, preferably on a carrier employing the latest developments in washdown equipment which includes the individual "quick on and off" nozzles strapped onto the aircraft, as well as nozzles on the carrier.

2. Thorough study be made of the material damage done to aircraft by the washdown system and that steps be taken to decrease the possibility of such damage. For example, cockpit covers should be put on all aircraft parked on the flight decks and small "quickly removable" covers should be put on the front of the engine cowling of propellor-driven aircraft. Further, ignition leads to the spark plugs should be made more resistant to corrosion and the effects of water.

3. The following optimum procedures be tentatively selected to decontaminate aircraft. They are based only on the decontamination effectiveness and manpower results of this project and past experience and do not take into account the availability of equipment or supplies. The procedures follow:

### To decontaminate an aircraft aboard a carrier

A. That has not been subjected to washdown

(1) Emergency period, to be ready for a strike.

a. First choice, 1 firehosing (fastest).

Second choice, 1 hot liquid jet washing (most effective).

(2) Operational period, a clean-up for future operations.

a. First choice, 1 hot liquid jet washing (most effective).

Second choice, 1 firehosing (fastest).

b. Scrub with detergent.

B. That has been subjected to washdown

(1) Operational period, a clean-up for future operations.

a. Scrub with detergent.

To decontaminate an aircraft on land (ashore)

- A. That has been subjected to washdown or operational decontamination
  - (1) Industrial decontamination.
    - a. Scrub with Gunk.
    - b. Repeat scrubbing with Gunk until cleared.
- B. That has not been subjected to any decontamination
  - (1) Industrial decontamination.
    - a. First choice, one hot-liquid-jet washing (most effective).  
Second choice, one firehosing (fastest).
    - b. Scrub with Gunk.
    - c. Repeat scrubbing with Gunk until cleared.

4. The rate and efficiency of decontamination operations be further studied and that work be done to develop decontamination methods and equipment readily adaptable to the tactical situation. Two suggested areas of effort are: (1) mechanical scrubbing equipment, and (2) development of more effective detergents.

5. A military exercise be planned and executed in which a carrier with aircraft on the flight deck is contaminated at a weapons test and reclaimed and put back into action using military personnel for most of the work. This exercise should simulate conditions similar to actual wartime conditions within the limits of radiological safety.

6. A training program based on the best current information be organized to train the appropriate personnel to decontaminate aircraft.

7. A radiological recovery manual for aircraft be prepared.

## Chapter 6

# SHIPBOARD INTERIOR CONTAMINATION

N. R. Wallace  
F. K. Kawahara

J. C. Sherwin  
J. V. Zaccor

The problem of radioactive contamination in the interior of two ships subjected to fallout from a thermonuclear explosion was investigated in three areas: ventilation cubicles in the No. 3 holds, machinery space, and weatherside areas. One ship was equipped with a washdown system; the other was not. Measurements were made of the average concentration of airborne particulate matter and of the radioactivity of deposited material in each of these areas. It was found that the average airborne activity concentration in cubicles ventilated by unprotected duct systems was on the order of 0.02 percent of the average weatherside concentration. The paper filter and electrostatic precipitator ventilation protective devices reduced this value still further.

Data are presented regarding deposition of activity inside ventilation and boiler air ducts and on deck.

### 6.1 BACKGROUND

Few experiments have been performed to obtain information relating to the radiation hazard to personnel in below-deck spaces resulting from an atomic or nuclear explosion. Operation Crossroads exposed a number of ships to the base surge of an underwater atomic burst. Studies of these ships yielded an estimated airborne activity level of 1 c/cu ft of air at 1 minute after the shot (Reference 12). The USS CRITTENDEN, one of the ships present at Crossroads, was examined 1 1/2 years after the shot for ventilation duct contamination (Reference 13). The activity which must have entered the ventilation system at the time the base surge reached the CRITTENDEN was calculated to be about 370 c of beta. Of this activity, 160 c was in a respirable particle size range ( $< 5 \mu$ ). No estimate was made of activity per cubic foot of air because this ventilation system was not operated during or after the test. However, it was stated that the after engine room would have drawn in enough active aerosol to immobilize and kill the occupants had the ventilation system been operating.

A theoretical treatment has been done on the potential hazard to personnel in boiler rooms from gamma radiation through boiler air supply ducts and from leakage of respirable material through boiler casings. It was concluded that in the case of no appreciable deposition inside the ducts, personnel combat effectiveness would not be reduced. However, the gamma-radiation hazards might become serious if deposition were significant.

Similar theoretical work has been done on the problem of contaminated material carried into ventilated compartments (Reference 14).

Two cases were considered: Case 1, wherein all airborne activity settled on the floor of the ventilated compartment, and Case 2, wherein all airborne activity moved through the space without deposition. This work was concerned with ship stay times in the cloud or base surge of the order of minutes within minutes after the burst. Depending on the entrance time, stay time and exit time from the cloud, below-decks doses would range between 1 to 7 percent of topside doses for Case 1. It was concluded that inhalation hazard would have no immediate effect on personnel for Case 2.

An effort has been made to simulate base surge conditions with cobalt chloride as a simulant (Reference 15). It was found that cobalt chloride concentrations at the vent terminals in the ventilated spaces ranged from 15 percent of the weatherside intake concentrations when the fans operated, and to about 0.2 to 1 percent when they did not.

Recently there was investigated a circumstance in which contamination was carried into the ventilation systems of the USS PATAPSCO, which at the time of fallout was considerably outside the range of both physical damage and base surge (Reference 16). Although the exact magnitude of the fallout was not determined, a maximum reading of 4 rm/hr was obtained with an AN/PDR-8 at H +13 hr. The study was made with a survey meter between 18 and 25 days after the shot was fired. At the time of measurement, concentrations of 1 to 18 d/m/cu ft were found in various ventilation ducts.

In general, past efforts have indicated a need for more information on the behavior of ventilation and boiler air systems in permitting entrance to airborne contaminants. Operation Castle provided an opportunity to study the characteristics of a ship's interior contamination in a region of fallout beyond the range of structural damage and base surge.

## 6.2 OBJECTIVE

The purpose of this investigation was to determine the concentration and distribution of radioactive, airborne particulate matter in shipboard ventilated spaces and firerooms resulting from a ship's exposure to the fallout from a thermonuclear explosion. Since a radioactive aerosol could contribute a significant proportion to the overall personnel hazard aboard a ship beyond the range of blast damage, special attention was given to: (1) evaluation of the following countermeasures for protecting the ship's interior against the ingress of contamination: washdown, ventilation duct protective devices, and fireroom vent closures; (2) time-of-arrival and intensity measurements of the radioactive aerosols; (3) collection of data concerning the deposition of radioactive material in the test systems; and (4) existence of significant gamma radiation fields originating from ventilation and boiler air ducts.

## 6.3 EXPERIMENT DESIGN

Two ships, the YAG 39 and YAG 40, were modified as test ships for Project 6.4. The YAG 39 was equipped with a washdown system; the YAG 40 was not. Complete testing was planned only for the unprotected ship.

To accomplish the objectives of the project, design specifications for the shipboard installations were determined so that features found in combatant ships were incorporated in the test ships, as well as suitable instrumentation. Pertinent features of the installations in the ventilation and boiler spaces are discussed in the subsequent sections.

6.3.1 Ventilation Spaces. The site of the ventilation tests on each ship was the No. 3 hold between Frames 68 and 88. Here the ventilation intakes were forward of the main superstructure where airborne material would be unobstructed (Figure 6.1).

The between-deck space of the No. 3 hold of the YAG 40 was divided into six identical cubicles, 16 by 25 by 10 feet. These compartments were separated into two groups of three separated by a passageway along the centerline. Each cubicle was complete with its own duct system and watertight door opening on the passageway. A deckhouse, 33 by 20 by 8 feet was built on the main deck of each ship directly over the No. 3 hold. This deckhouse provided an enclosure for the ventilation intake ducts which protruded through its top.

The YAG 39 arrangement was identical to that of YAG 40, except that only test Cubicle II was built into the between-deck space, as shown in Figure 6.4.

After consultation with interested codes from BuShips and NRL personnel who had previous experience in shipboard measurements of airborne particulate matter, the following concepts were agreed upon:

(1) All systems would be designed and built according to Navy specifications for the volume of air they were intended to carry. They would provide adequate flow characteristics for volume of air measurement and sampling. The nominal system capacity would be 1000 cfm.

(2) Elements common to Naval systems would be included wherever possible (see Appendix E). All systems would have the same mushroom head type of entrance.

(3) The systems were to be as closely alike as possible except for one feature in each which was to be compared with a 1000 cfm "standard" system. A duplicate of the standard system would be installed on the YAG 39.

(4) The test situations are given below. Their designation by condition number is used throughout this report.

Conditions for YAG 40

Effect or Device Tested

I	2/3 speed fan operation, 670 cfm
II	standard system, 1000 cfm
III	fans off, no closures
IV	NRL precipitron, 1000 cfm
V	Wire mesh or standard Navy filter, 1000 cfm
VI	ACC paper filter, 1000 cfm

Conditions for YAG 39

IIA	effect of topside washdown, 1000 cfm
-----	--------------------------------------

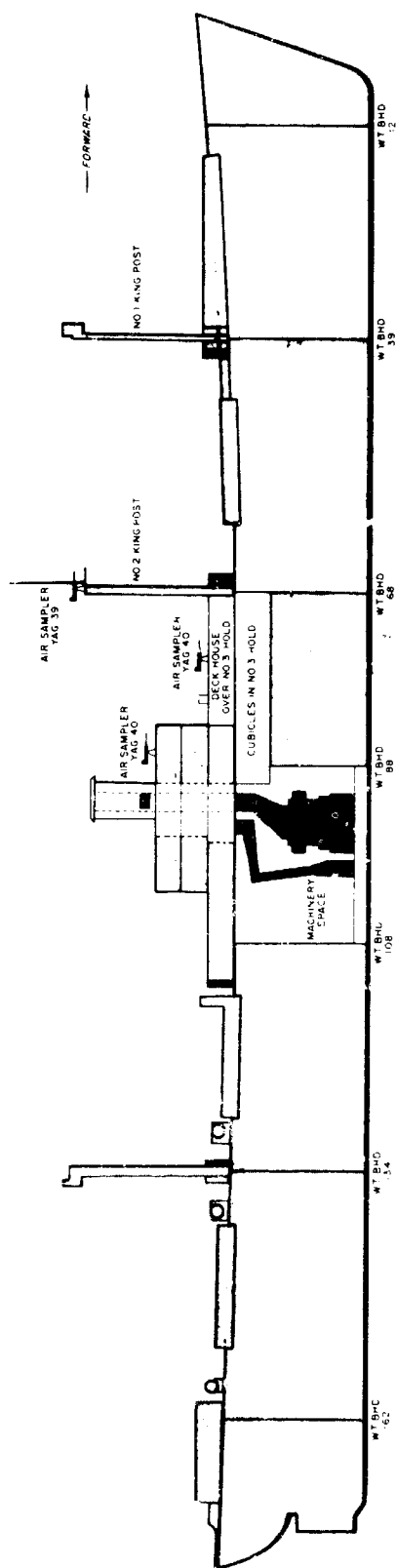

Figure 6.1 Locations of test areas aboard the YAG 39 and YAG 40.

Condition I, YAG 40, provided a test of the protection afforded to a ventilated cubicle when the fan is operated at low speed. Larger ventilation systems are frequently equipped with two-speed fans which can be adjusted to meet climatic conditions. To simulate the behavior of a two-speed system operated at two-thirds of maximum flow, single-speed ALD1W5 fans were built into the intake and exhaust ducts of Condition I. Since these fans run on direct current, their speeds could be adjusted to pass 670 cfm through the test cubicle.

Condition II, YAG 40, constituted the standard system and had the two-fold purpose: (1) to provide basic information on the behavior of a contaminant passing through a shipboard ventilation duct in a region of fallout and (2) to act as a standard of comparison with systems protected with a radioactive aerosol countermeasure. It carried the nominal 1000 cfm and was heavily instrumented.

Condition III, YAG 40, permitted study of the simple expedient of turning off the fans to discourage interior contamination under radioactive fallout conditions.

Condition IV, YAG 40, contained a Westinghouse precipitron mounted in the duct near the weatherside intake. Since this electrostatic precipitator had to be mounted vertically and space within the deckhouse did not permit such an arrangement, a small blister was built on top of the deckhouse to enclose the unit, Figure 6.7. This structure was duplicated on YAG 39 to maintain topside similarity between the two ships.

Access to the precipitron for cleaning was available through a watertight cover in the side of the blister and through a hatch to the interior of the deckhouse below. The precipitron power pack, impulse counter to determine frequency of arcing, and the cumulative running time meter were installed inside the deckhouse.

The right-angle turn made by the air exhausting from the precipitator necessitated the addition of a post-filter (Farr type A4A4) beneath the precipitator and ahead of the duct bend, to straighten the airflow through the precipitron. A similar pre-filter which normally accompanies the unit was installed.

The total pressure drop through this air cleaning assembly was sufficiently small (about 0.21 inches of water) that no major changes were needed in the ductwork to maintain 1000 cfm.

Condition V, YAG 40, contained a single Farr type A4A4, open mesh filter (2 by 22 11/16 by 23 5/8 inches) installed beneath the mushroom intake, Figure 6.8B. Otherwise, it was identical to Condition II.

Condition VI, YAG 40, contained a pleated paper filter (Chemical Corps Model E-19) mounted in a manner similar to that of the Farr filter in Condition V, Figure 6.8A. The high pressure drop of this filter (about 1 inch of water at 1000 cfm) necessitated an enlargement of the intake duct diameter.

Condition IIA, YAG 39, was identical in relative position and physical characteristics to Condition II, YAG 40. It was intended that a possible air-cleaning action of the washdown water on YAG 39 could be compared with the other protective devices on YAG 40.

For comparison among systems, it would be desirable to have all ducts identical in flowrate, shape, length, and diameter. However, difficulties arose when attempts were made to meet these requirements. The high-pressure drop of the paper filter in Condition VI obliged the

diameter of the intake duct to be increased from 8 inches to 9 1/2 inches to maintain a flowrate of 1000 cfm; thus, the air velocity in this duct was lower. Instrumentation intensified the problem of maintaining similarity. Each air sample taken from a duct necessitated, wherever possible, inclusion upstream of a minimum length of straight duct 7 1/2 diameters of the sampler. This length of duct had to be included in all the other systems, regardless of the presence or absence of a sampler.

Figures 6.2 through 6.8 show the components of the systems as

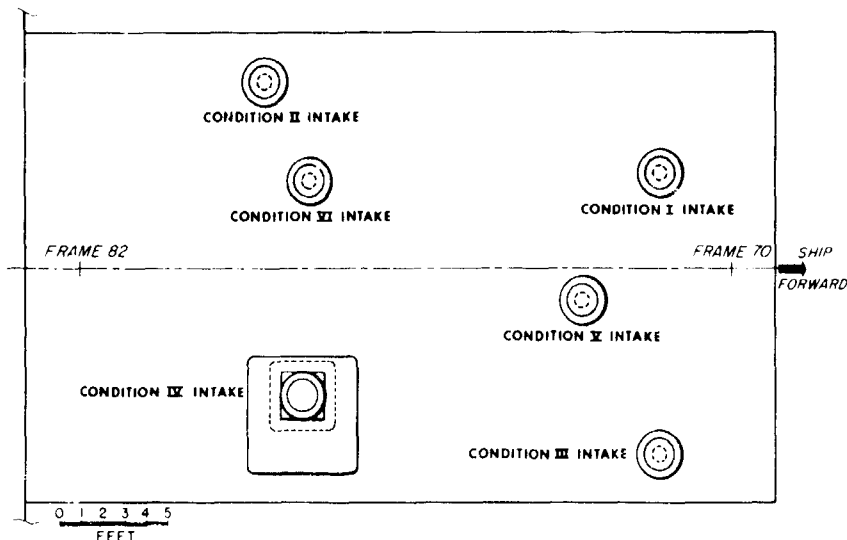

Figure 6.2 Plan view of the top of the deckhouse on the YAG 40.

they were installed. Appendix E gives pertinent flow characteristics and material details.

**6.3.2 Boiler Systems.** The existing boiler-air systems on the test ships were in no way comparable to those on combatant ships, and although extensive modifications were not feasible, similar minor modifications were made on each. Special attention was given the boiler-air and gas casings to the extent that all plates were straightened and new gaskets installed giving, within normal boiler-making practice, air- and gas-tight casings.

The principal similarity to combatant ships was a closed air system, air intakes, and uptake space. Principal features of dissimilarity to combatant-ship systems were low air capacity and velocity, type and location of blower, and path of air from blower to boilers.

Figure 6.9 shows a schematic arrangement of the boiler systems. The firing aisle lies between the two boilers at floor-plate level. The engine and machinery space lay aft of the boilers. There were no partitions between the fireroom and engine room.

For test purposes and, also, to insure a noncontaminated machinery space for operating purposes, the air supply to the boilers was fully enclosed, and all vents at the weather intakes were closed. Enclosure of the air supply was accomplished by providing louvered air intakes in the outer stack above the superstructure, closing the opening between the stack bonnet and outer stack, and sealing all openings in the boiler fidley through the superstructure to the top of the boiler space---



where a deck was installed, forming a space above roughly comparable to the uptake space on a combatant ship. The forced draft blower, located at the lower level beside the starboard boiler, was enclosed in a sheet-metal housing and an air duct was installed from the uptake space to the forced-draft blower housing.

Total discharge from the forced-draft blower, which was unaltered, was delivered to the space below the starboard boiler at the starboard

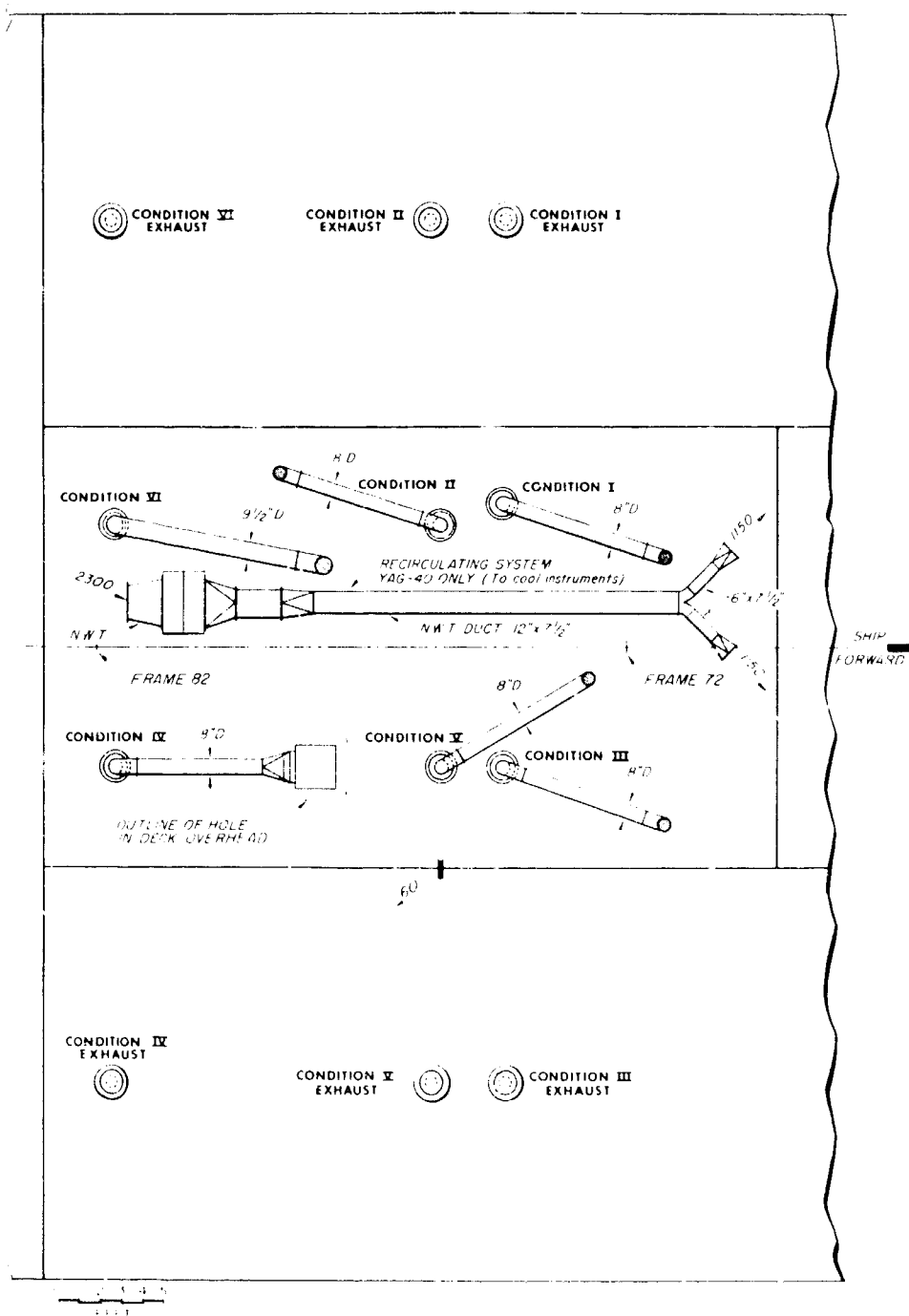

Figure 6.3 Plan view of the main deck level inside the deckhouse on the YAG 40.

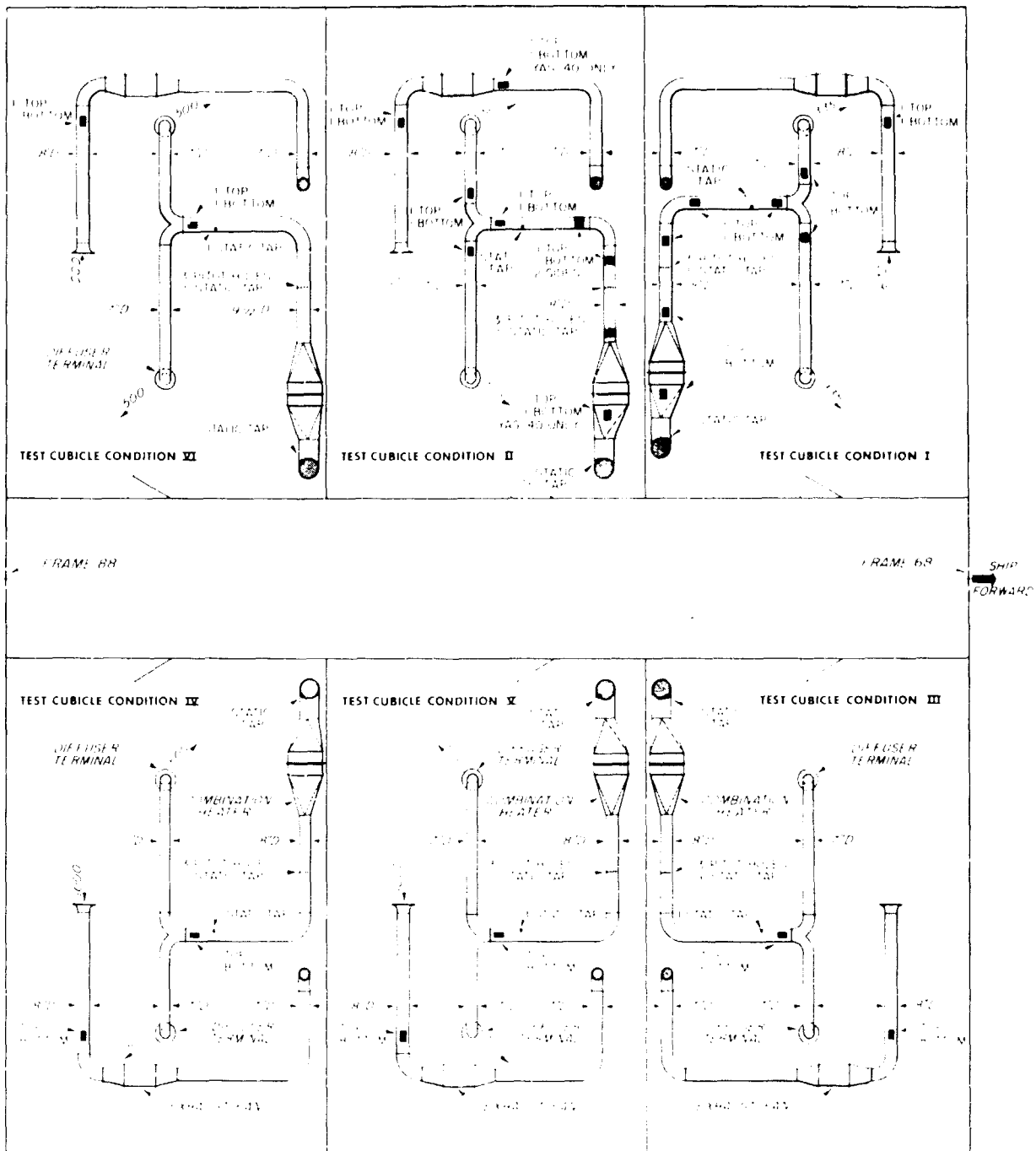

Figure 6.4 Plan view of test cubicles in the No. 3 hold of the YAG 40.

aft corner and thence to the burners at the front of the boiler and to the space below the port boiler by a duct between the two boilers.

The principal instrumentation requirement affecting the system design was the need for a straight duct section of  $7 \frac{1}{2}$  diameters ahead of the forced draft blower for sampling and flow rate measurements.

Pertinent flow data are given in Appendix E.

6.3.3 Data to be Obtained. Data were to be obtained not only from the two test areas just discussed but also from the weatherside of each ship. Obviously, information acquired in below-deck spaces would

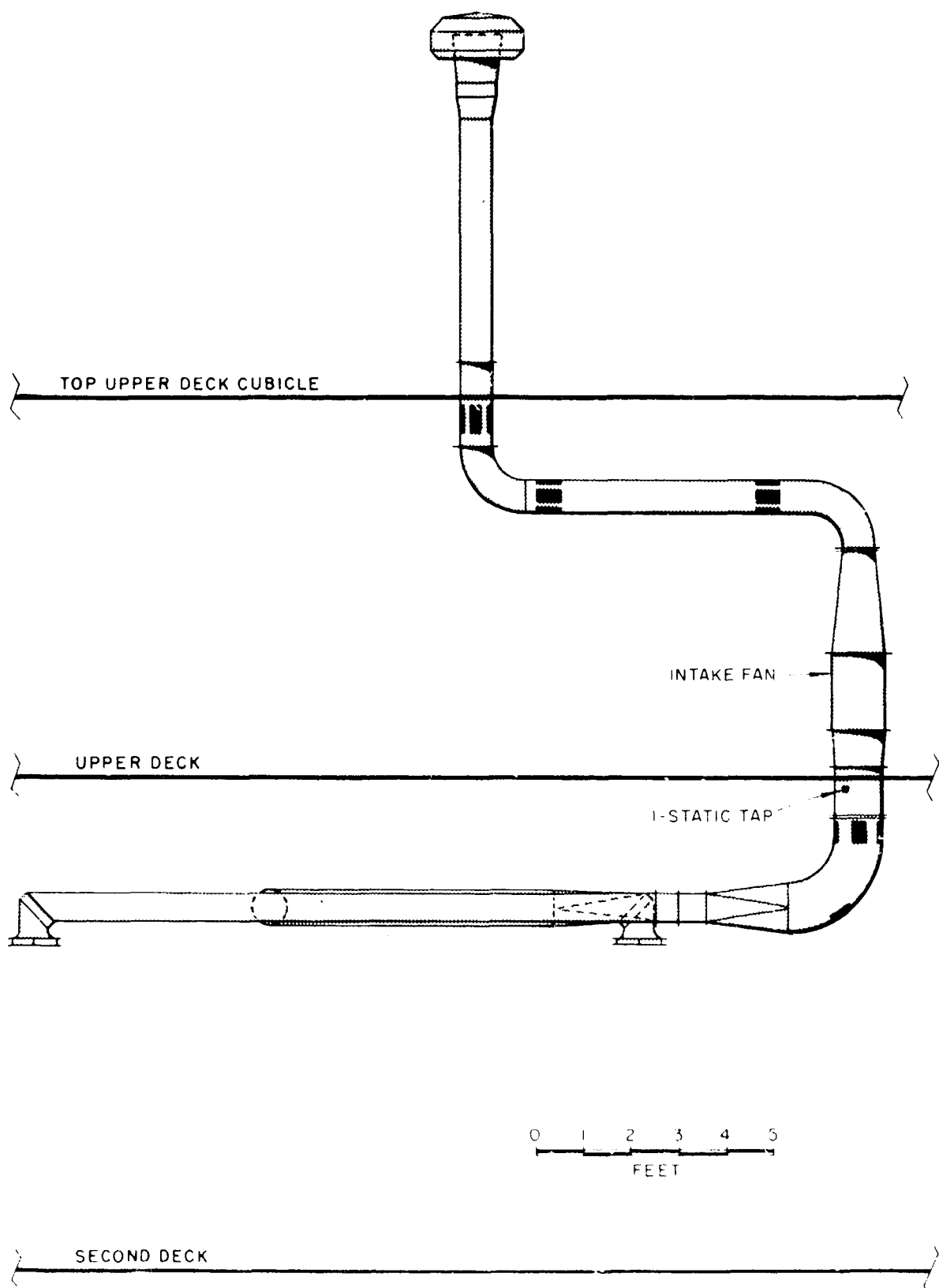

Figure 6.5 Elevation of a typical ventilation intake duct.

depend to a considerable extent on the type of radioactive fallout to which the test vehicles were exposed.

Data considered pertinent to the study of interior contamination were: (1) total activity carried into the below-deck spaces through

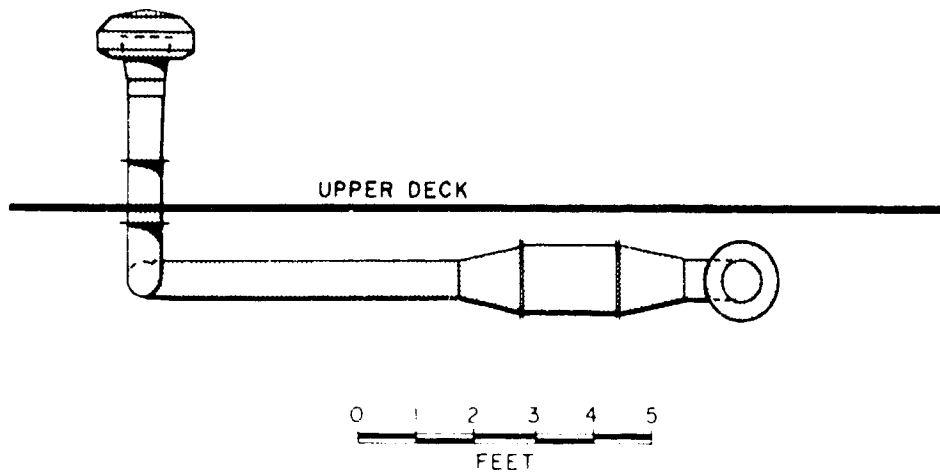

Figure 6.6 Elevation of typical exhaust duct.

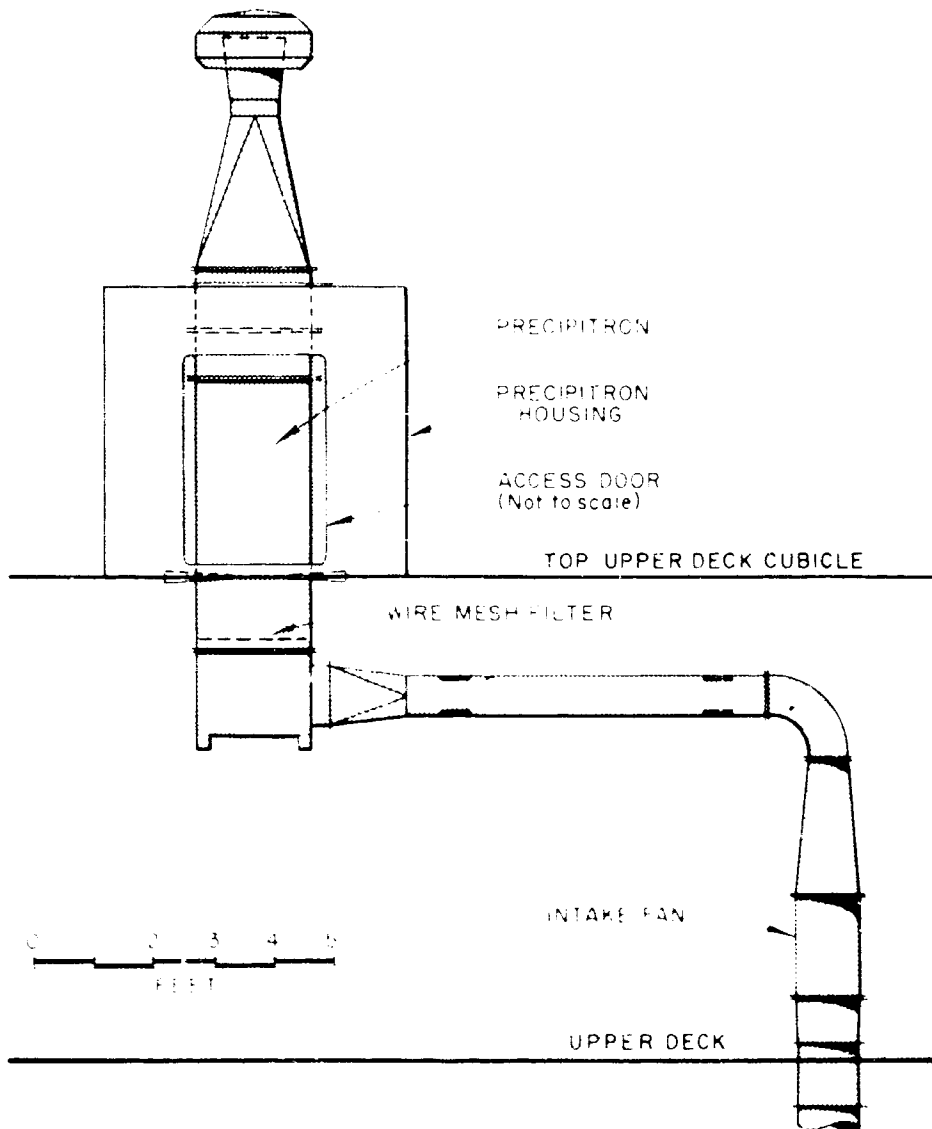

Figure 6.7 Elevation of the intake duct of Condition IV on the YAG 40.

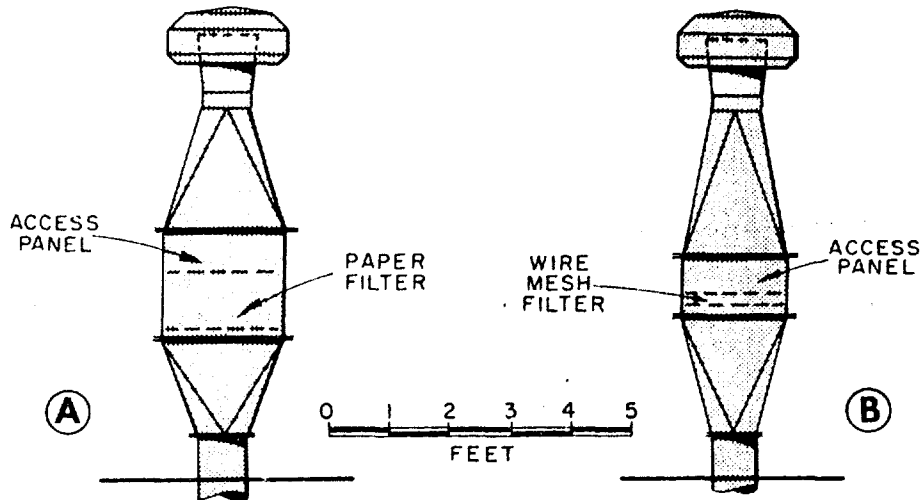

Figure 6.8 Elevation of weatherside intake ducts of Conditions V and VI on the YAG 40.

the ventilation and boiler air supply ducts and the fraction of this activity that was again exhausted to the atmosphere; (2) activity per unit volume of air carried into below-deck spaces as a function of time and activity per unit volume of air exhausted from the spaces as a function of time; (3) activity per unit volume of air above decks near the weatherside supply intakes of the boiler air and ventilation ducts as a function of time; (4) reduction of airborne activity concentrations as a function of distance in passing through the boiler air and ventilation supply ducts; (5) average particle size distributions of the active airborne particulates above decks and in the spaces below decks; (6) radioactivity of deposited material in such specific areas as the inside surfaces of air ducts and the interior surfaces of test spaces below decks; and (7) contribution made to the total gamma field intensity in the test spaces by activity deposits within the ducts and cubicles.

As a general rule, activity measurements within ducts or measurements on samples taken from ducts were made by gamma counting. Measurements made within the test spaces included counting both the beta and gamma activities. This practice permitted comparison of activity levels in various test areas on the basis of gamma counts without precluding a subsequent estimate of the biological hazard from beta activity in the cubicles.

#### 6.4 INSTRUMENTATION

For convenience, each ship was divided into three separate areas of investigation, because particular instruments and the kind of information they provided were often peculiar to these areas. The separate areas were: the test cubicles and their ventilation ducts; the machinery spaces and the boiler air ducts; and the ship's weatherside. Operational difficulties made this separation more distinct in that intercomparison of

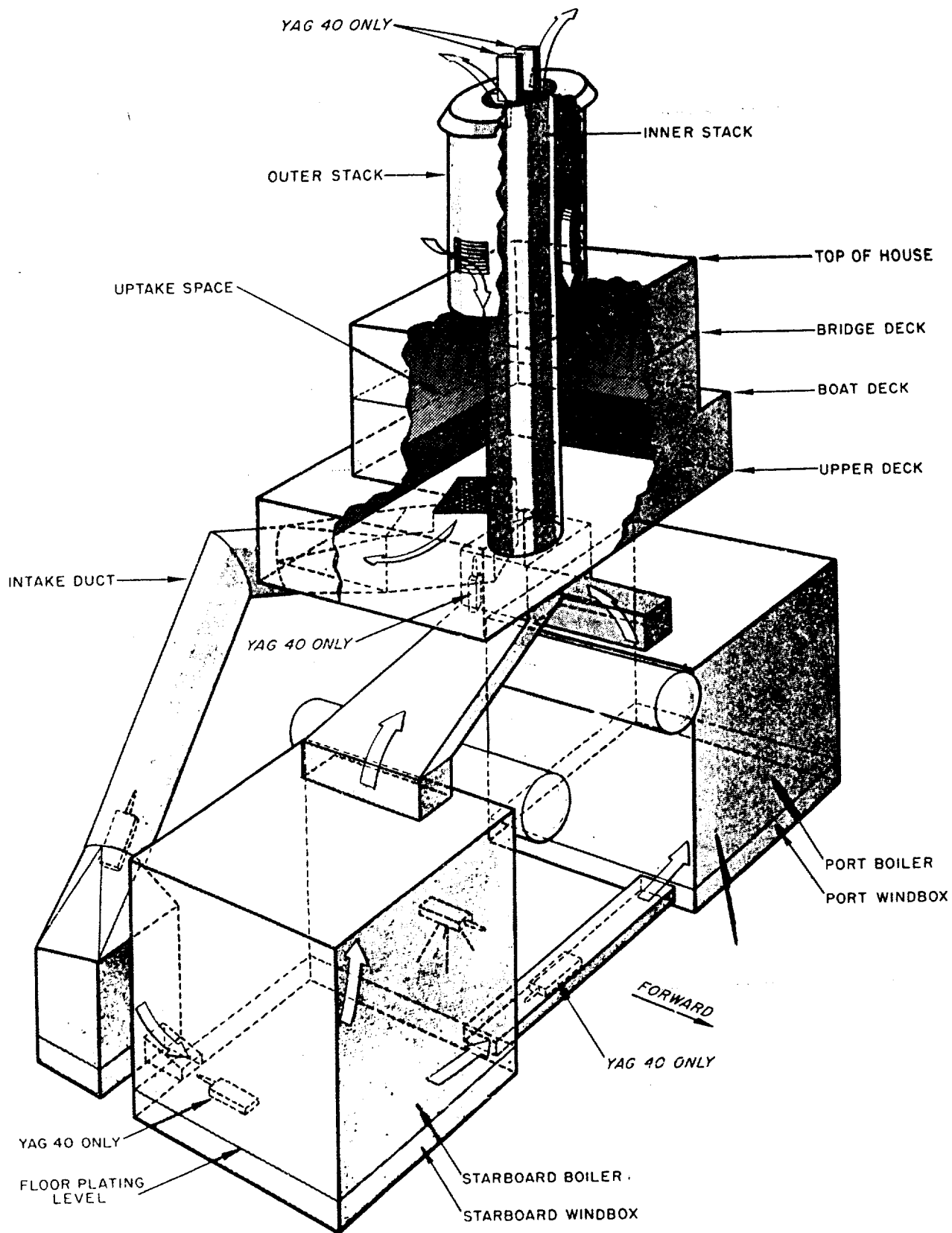

Figure 6.9 Schematic of the boiler air systems on the YAG 39 and YAG 40.

data from the three areas was frequently compromised by the different kinds of sampling or measurement bias associated with each.

6.4.1 Measuring Devices. A continuous air sampler was designed to collect particulate matter on a continuous filter strip to record concentration of airborne activity with time. It basically constituted a constant-flow, positive-displacement suction unit (Reference 17) drawing air from the sampler case, which admitted air through the small end of a diffuser cone placed just ahead of the moving filter strip. Wherever possible, the intake air velocity was isokinetic with respect to the ambient airstream. The diffuser cone was lined with copper foil, which could be removed and counted so that airborne material depositing inside the cone could be accounted for in the analysis of the filter strip.

The dimethylterephthalate (DMT) particle collector was used to augment data on the average activity per unit volume of air. The sampler consisted of a sampling head with a removable cylindrical intake 4 in. in diameter and 4 in. long leading to the main body, which was tapered conically to a standard 1-in. male pipe fitting. This in turn was connected through standard pipe fittings to a constant volume suction unit. The sublimable crystalline filter medium was packed in a fairly tight disc-shaped planchet 4 in. in diameter and  $\frac{3}{8}$  in. thick. This planchet was held between two screens of wire mesh (No. 100) to allow free flow of air through the filter material and yet maintain its shape. The power supply and sampling period was the same as for the continuous air sampler.

The molecular filter particle collector was designed to obtain samples for size frequency distribution measurements of active particles and was eventually used to provide data on the average activity per unit volume of air. This sampler was similar to the DMT sampler, except a molecular filter was used in place of the planchet of DMT and a cylindrical intake 0.56 in. long was substituted for the 4-in. one. In addition, each station had two collecting heads with a volume sampling ratio of 30 to 1 controlled by a metering orifice built into the low-volume head. The heads were mounted on opposite ends of a T-shaped pipe fitting separated a distance of 21 to 22 in. The head assembly was positioned at approximately a head level of  $5\frac{1}{2}$  ft. when coupled directly to the constant volume suction unit.

The duct sections were removable pieces (4 by 6 in.) of the ventilation and boiler-air-supply ducting having a similar galvanized surface and the same curvature as the ducts themselves. In the upper regions of the boiler-air intake, where the walls of the ducts were flat, surface samples (4 by 6 in.) were glued to the inside faces at specified intervals. The duct sections were held tightly in place by a backing plate with a cushion of foam rubber (Figure 6.10). Each of these sections had the same surface area to facilitate comparison of activity counts. These sections provided data for estimating the external hazard in the vicinity of the ducts due to deposition of activity along their inner surfaces and for determining deposition patterns of particulate matter thrown out by an airstream passing through the ducts. In addition, a comparison of the duct sections from the stations located near the tips of the air-sampler cones indicated, by the degree of uniformity in the activity

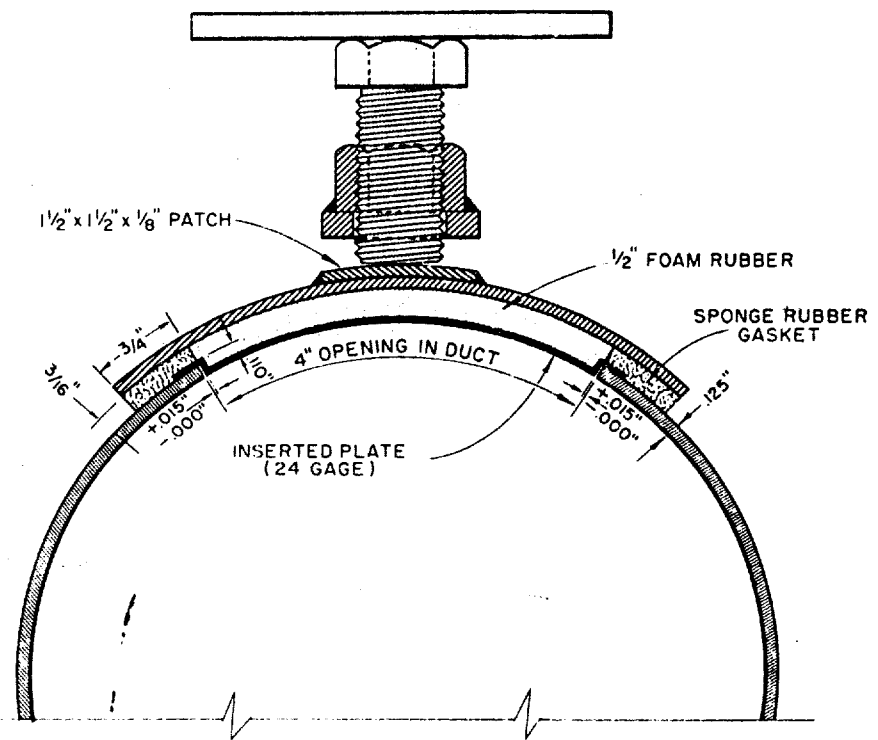
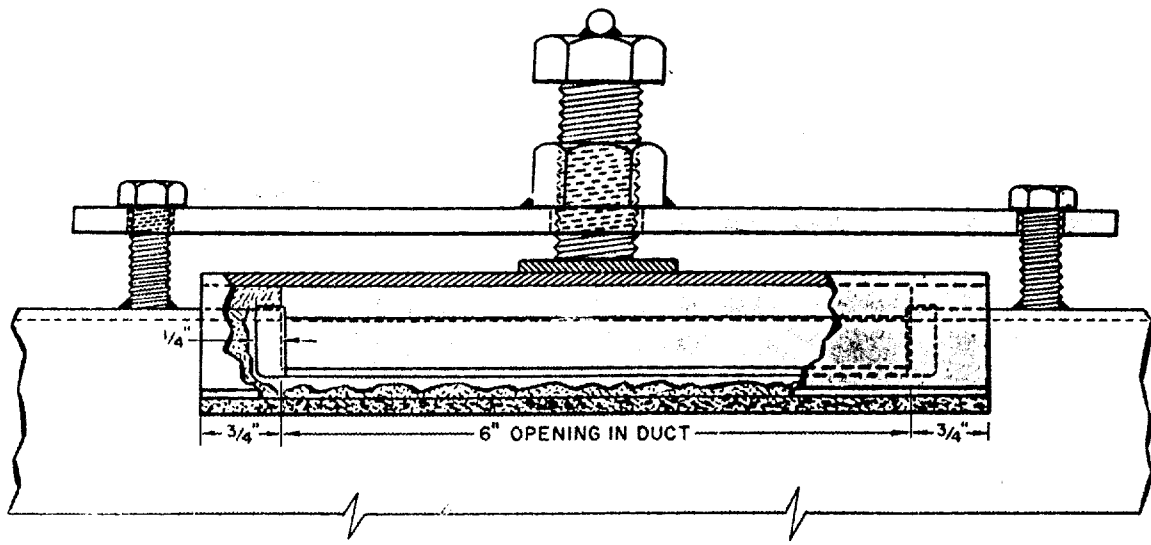

Figure 6.10 Typical duct assembly.



deposited, the effect of gravity and transitional flow at the elbow on the representativeness of the air-sampler collection at that point.

Multirecord temperature recorders were installed at a central location on the two test ships. Temperature-sensitive resistance bulbs were located at air-sampling stations throughout the firerooms, ventilated cubicles, and above decks.

Pressure-differential recorders were set up to record the static-pressure differences in air ducts. Bellows-type diaphragms were used as the pressure-sensitive elements in these recorders to eliminate the influence of ship motion.

A record was also made of barometric pressure and humidity on the YAG 40.

Detailed descriptions of the sampling devices are given in Appendix D.

6.4.2 Installations in the Ventilation Systems The extent of the installation of sampling devices in the ventilation systems of the test ships is shown in Table 6.1.

The air samplers in the ventilation systems were installed on towers,

TABLE 6.1 INSTRUMENTATION IN VENTILATION CUBICLES<sup>(a)</sup>

Sampling Devices	Number of units						YAG 39 Cond.IIA
	YAG 40						
	Cond. I	Cond.II	Cond.III	Cond.IV	Cond.V	Cond.VI	
Air samplers <sup>(b)</sup>	2	5	1 (sampling from air in cubicle)	1	1	1	2
Molecular filters <sup>(b)</sup>	1	1	1	1	1	1	1
Temperature recording elements	1	1	1	1	1	1	1
Flow recording instruments	1	1	1	1	1	1	1
Gamma-time intensity chambers	1	1	1	1	1	1	1
Duct sections	25	40	13	9	9	9	28

(a) Exact location of each air sampler and duct section with respect to the duct from which it samples is given in Section 6.6.

(b) One suction unit attached to each unit.

located at elbows, in such a manner that the cones projected upstream past the elbow a minimum distance of one duct diameter to reduce the effects of the elbow on the flow at the sampling point. The cones entered the ducts through a rubber diaphragm made by stretching a section of innertube over the hole in the elbow (Figure 6.11).

Four adjustment bolts on the air-sampler mounting afforded a means of aligning the axis of the cone with the axis of the duct. The cones for all samplers were cut off to present the proper intake area for isokinetic sampling wherever sampling was from a moving airstream. Where sampling was from a large enclosed space, cones were cut off to present the maximum intake area and still retain the desired feature of channeling the air against the moving filter-paper strip.

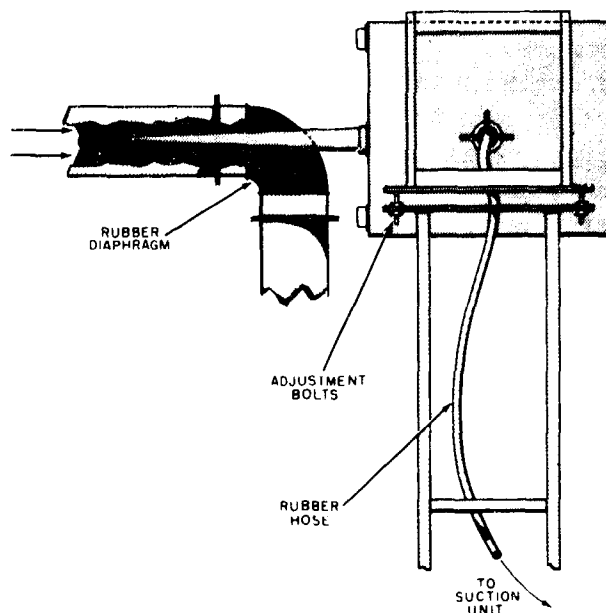

Figure 6.11 Schematic of typical short type continuous air-sampler installations.

The short sampler used throughout the ventilation system was designed to occupy as little horizontal space as possible. The long runs of ventilation ducting required for air straightening left little room between the elbows and the bulkheads. Furthermore, it was necessary to eliminate turns in the airstream once it had entered the cone to minimize loss of particulate matter to the sides of the entrance cone. Consequently, all continuous air samplers collecting from specific parts of the ducts were mounted behind elbows.

Each cubicle contained at least one air sampler located at the first elbow of the exhaust duct except the cubicle for Condition III, in which the sampler was mounted off the deck near the center of the space. The exhaust-duct samples were intended to act as indices of the airborne particulate concentration in each cubicle. The standard system contained four samplers in the intake duct spaced behind the first and second elbows, the fan, and the combination heater, in addition to the exhaust-duct sampler. This arrangement permitted a thorough study of the change in concentration of the airborne matter passing through the duct. Cubicles for Condition IIA and Condition I each contained a sampler at the first elbow of the intake duct, in addition to the exhaust duct sampler, for comparison with the equivalent sampler in Condition II.

The suction units for the air samplers were distributed arbitrarily in the cubicles commensurate with the requirement that they be within 10 ft (one hose length) of the air samplers they serviced.

Each of the seven cubicles contained one molecular filter holder attached to and supported by its own suction unit. These collectors were placed near the centers of the cubicles to reduce possible distortion

of the airborne particle populations near bulkheads, but their horizontal axes were randomly oriented.

The center of each cubicle was occupied by a gamma time-intensity detector. Duct sections in Conditions IIA and II were intended for primary deposition measurements. Duct sections were placed in the other systems for comparison with Condition II. Where duct section stations occurred in straight runs of ducting, a minimum of two sections, one top and one bottom, were placed diametrically opposite each other. In some cases, as in Condition II, as many as four sections were located at each station to give a more-complete coverage of the inner surface of the duct. Duct sections are shown as black rectangles in Figures 6.4, 6.5, and 6.7, and exact locations with dimensions are given in Figures 6.15 and 6.16.

An air-sampler installed in the exhaust of one of the cubicles is visible in the right background of Figure 6.12. Its suction unit and

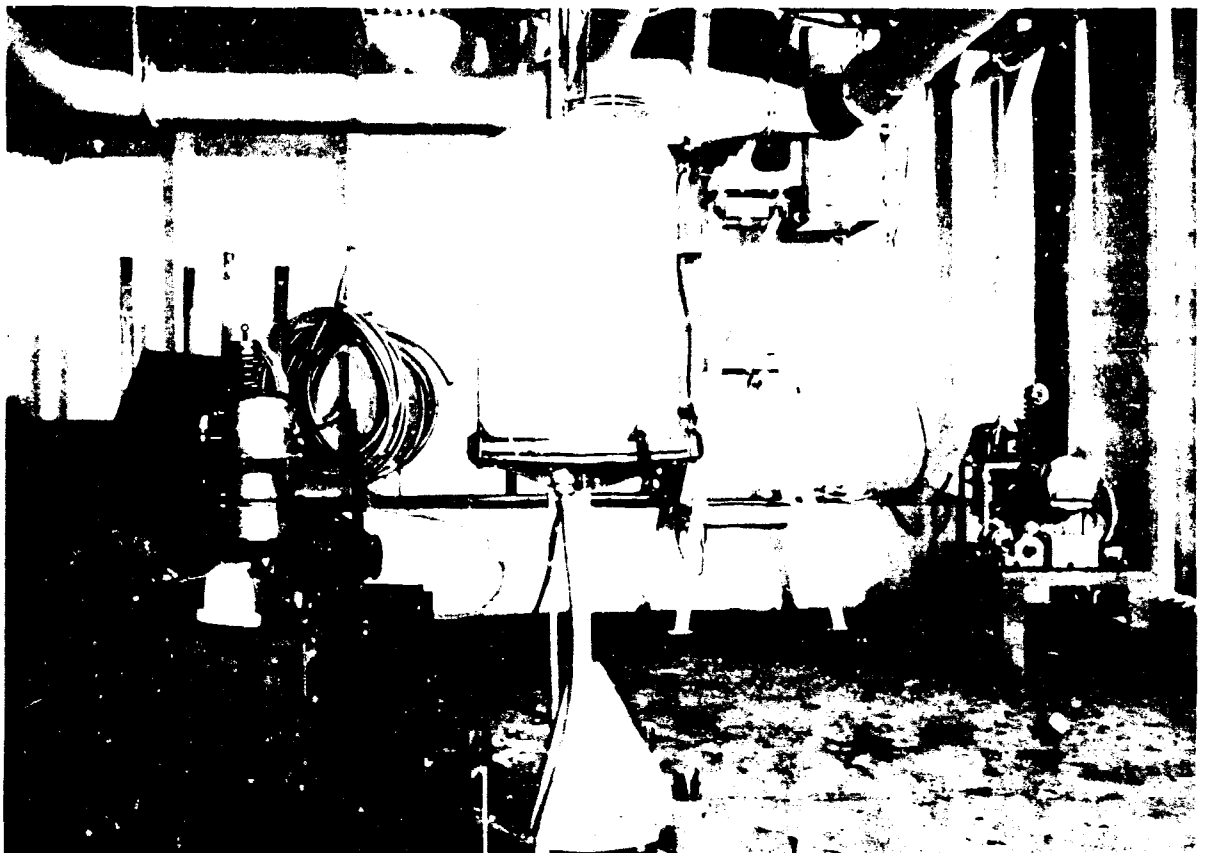

Figure 6.12 Typical air sampler and suction unit arrangement.

that for a molecular filter collector also appear without their protective covers. The center of the figure is occupied by a gamma time-intensity detector.

6.4.3 Installations in Boiler Systems. Sampling of boiler air and sampling in the fireroom spaces presented difficult problems. The high concentrations of flyash and general background dirt caused inordinate filter loading. Since high ambient air temperatures handicap the opera-

tion of electric motors and pumps, both suction units and continuous air samplers were susceptible to damage by the fireroom temperatures.

Since sample recovery from the boiler-air suction units was planned and because their locations were not dependent on those of the continuous air samplers or molecular filters they serviced, all the units were grouped together in a special refrigerated box aft of the forced draft blower in the bottom level of the fireroom of each ship.  $1\frac{1}{2}$ -in. galvanized pipe ran from the refrigerated box to each air sampler and molecular filter location. Since the suction unit adjusted automatically to variations in pressure drop ahead of the pump, variations in length of intake pipe, within reasonable limits, did not affect the rate of flow of air through the sampler.

Suction units which pulled air through samplers located in the boiler ducts exhausted the air into the duct downstream of the last sampler; where the sampler was located in the fireroom, the sampled air was exhausted back into the fireroom. These precautions were taken to avoid interference with boiler casing air leakage since the suction units were capable of pumping 60 cfm into the fireroom against a pressure drop of 8 in. of mercury.

For the most part, continuous air-samplers were located throughout the firerooms and boiler ducts in regions of unavoidably high temperatures. Since individual refrigeration systems would make sample recovery too slow under circumstances where speed was essential, the long-type air samplers were designed around temperature-resistant components: glass-wound motors, asbestos gaskets, silicone-rubber seals and high-temperature grease.

The lack of convenient bends in the boiler-air ducts required the entire sampler be placed inside the duct to meet the conditions of a straight sampling intake. The long, narrow case design presented a minimum frontal area to the airstream. To simplify the construction of these machines and the recovery of samples from them, the long-type sampler was used throughout the boiler systems.

Air-sampler locations in the boiler ducts and firerooms of YAG 39 and YAG 40 are shown with dotted lines at the various stations in Figure 6.9. Starting at the first sampler upstream in the duct, the following samplers are shown for the YAG 40:

1. Air sampler beneath fidley or uptake space: Body of the sampler was in the fireroom above the port boiler. The cone protruded vertically upward through the duct and turning vanes to collect a sample as the air entered the duct. The air temperature next to the sampler was nearly 200°F under closed fireroom conditions.

2. Air sampler ahead of forced draft blower or fan: Entire unit was mounted centrally in the duct with the axis of the cone parallel with the axis of the duct. Access was obtained through a panel on the lower side of the duct just above the blower housing.

3. Air sampler in starboard windbox: Sampler lay on the floor of the windbox beneath the floorplate level. The cone pointed upstream toward the fan housing. This unit was destroyed by salt water corrosion after Shot 1 when the windbox became flooded.

4. Air sampler in duct connecting boiler windboxes: Arrangement was similar to Item 3 in that the sampler lay on its side with the cone pointing upstream.

5. Air samplers at top of stack: Since the exhaust stack was divided down the middle to provide a separate exhaust for each boiler, two air samplers were stationed side by side at the top of the stack. Both pointed vertically downward. Neither operated satisfactorily and were abandoned after Shot 1 (see Appendix E). The suction units for these samplers were weatherside of the flying bridge.

6. Air sampler between boilers: Supported by a tower about  $7\frac{1}{2}$  ft off the floor plates of the firing aisle. The sampler was located centrally between the two boilers and was the only unit which was intended to collect a time differentiated sample from the fireroom.

Of the samplers described, only two were duplicated on YAG 39. These were the sampler ahead of the blower and the one in the fireroom between boilers.

All the units in the air ducts or collecting from the ducts on YAG 40 were meant to determine the loss of airborne activity between various sections of the boiler system which were instrumented, whereas the samplers in the firerooms of both ships were primarily intended for a determination of the airborne activity concentrations. The continuous air sampler ahead of the blower in the intake duct of YAG 39 was installed for a comparison of the washdown countermeasure with the unprotected YAG 40 system.

One molecular filter particle collector was located in the boiler room of each ship between the boilers about 1 ft from the air-sampler towers. The sampling heads were oriented at random. These particle collectors were to furnish samples for particle-size-distribution studies but could also be used for estimating an average activity per unit volume of air. However, the filters loaded with flyash so rapidly that flow rate through the sampling heads dropped almost to zero within 20 min after suction was started.

Duct sections were placed circumferentially at chosen locations around the boiler-air-supply ducts of the two ships. Surface samples were glued to the inside surfaces of the fidley spaces. No duct section installations were made downstream of the forced-draft-blower housing (see Figure 6.17 through 6.19).

6.4.4 Weatherside Installations. Weatherside instrument locations are shown in Figure 6.1. Primary interest lay in collecting samples near the intakes to the various below-deck spaces. This objective was compromised on YAG 39, where the instruments were mounted on the kingposts to avoid the washdown spray.

Three long-type air samplers with normal temperature components were modified for outside operation. These units were equipped with tail fins and pivot mounts to keep them oriented into the wind. Two of the samplers were mounted on YAG 40, one on the port side of the top of the deckhouse over the No. 3 hold and the other on the starboard side of the flying bridge forward of the stack. Figure 6.13 shows the deckhouse sampler closed up for sampling with the intake cone, suction hose, and power cable removed. Figure 6.14 depicts the same unit opened for recovery or maintenance. Its suction unit is visible in the background and the sampler on the bridge appears in the top center.

The third air sampler was stationed on the port side of the No. 2 kingpost of YAG 39.

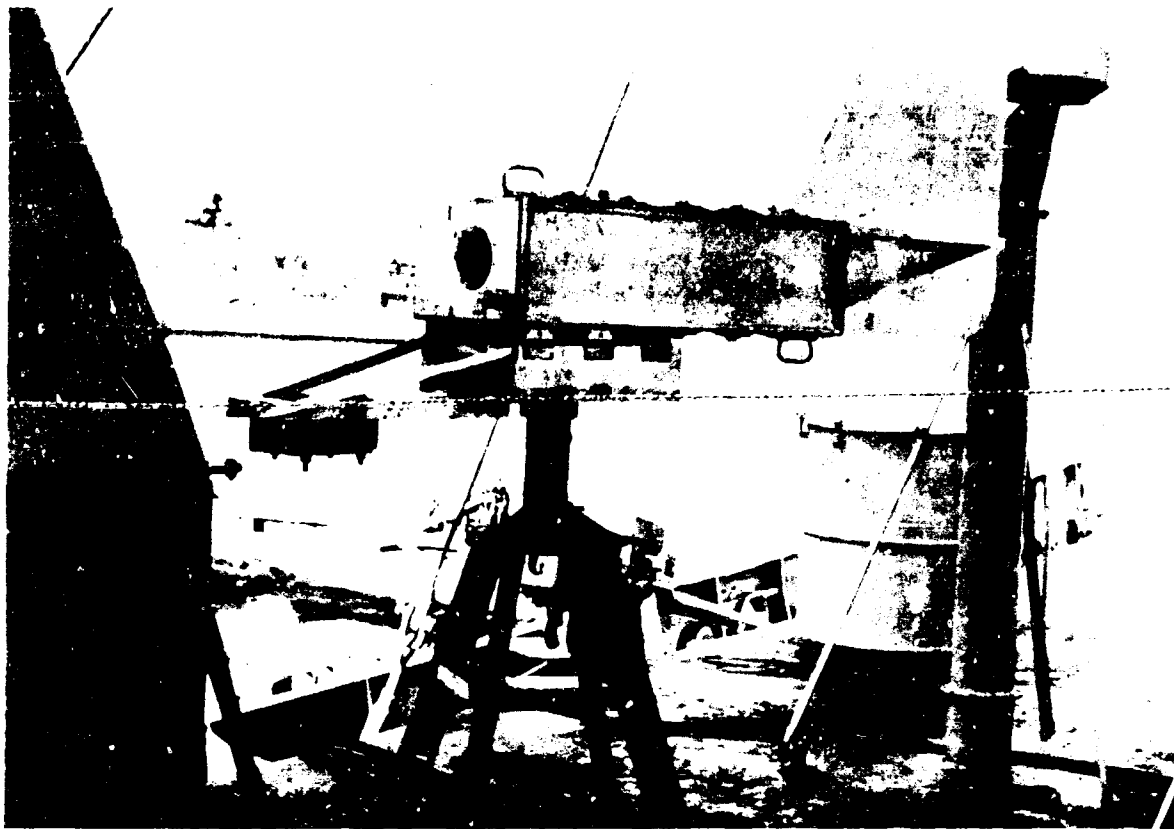

Figure 6.13 Typical weatherside continuous air-sampler installation.

There were three types of particle collectors located on the exterior of the ships: molecular filters, DMT filters, and gummed or adhesive-coated collectors (Reference 6). One molecular-filter assembly was mounted near each weatherside air sampler. When the molecular filters were installed, they were intended only for collecting particles for size analysis and individual particle studies. Therefore, no effort was made to orient them with the wind or to protect them from direct fallout. It was later found that particle-size distributions could not be successfully derived from these samples. Furthermore, this method of exposing the filters did not permit an estimate of the air sampled.

The two DMT collector heads were located on the top of the flying bridge of YAG 40 within about 6 ft of each other. They were exposed only to Shots 4 and 5, since they were attached to the two suction units previously associated with the unsuccessful attempt to collect a stack exhaust sample. One DMT collector from each shot was used to obtain an estimate of air above decks.

Gummed paper collectors, obtained from Project 2.5a in the field, were also added to the interior contamination's weatherside assemblage of collectors after Shot 2. Three of these collectors were exposed on Shot 4 and four were put out on Shot 5.



Figure 6.14 View of weatherside air sampler opened for recovery or maintenance

#### 6.5 OPERATIONS

Of the four shots in which the test ships participated, only Shots 2, 4, and 5 provided data for the study of interior contamination. No samples were returned to NRDL for analysis after Shot 1. Samples from Shots 2, 4, and 5 arrived at NRDL about 3 to 7 days after each shot.

6.5.1 Instrument Timing. Prior to the field operation, it had been planned that all power driven instruments would be started at S-2hr and that they would continue operating until S+6 hr.

Since it was intended to start all instruments manually just before debarkation, a master switch panel was established on each ship in a readily accessible area. The test areas in the No. 3 holds of both ships were the site of the switch panels and recording instruments for each ship, because these locations were close to most of the instruments and were fairly uniform in temperature (about 80°F). Power for sampling instruments was derived from two 60-kv alternating-current diesel generators operated in parallel. The instruments were wired to the generators through a single trunk line, which contained a timer-controlled circuit breaker. Although the samplers were started individually at about 5- to 10-sec intervals to avoid a serious voltage drop at the generators, they were stopped simultaneously when the breaker opened. This circumstance caused a difference in the total time of operation between the first and last started samplers of about 10 min. This difference was disregarded in the treatment of the results.

The test-cubicle fans were connected to the generators through a different circuit, which was not equipped with a timer for Shot 2. The fans continued to operate until the generators ran out of fuel at an estimated 4 hr after the instruments shut down. The instruments were not started at S-2 hr, as planned, but at S-3½ hr.

Shot 2 operation demonstrated that the 8 hr for which the timer had been set was not sufficient for the instruments to span the entire time of fallout. The heavily instrumented YAG 40 was just beginning to get significant fallout when the power operated instruments shut down. On the two succeeding shots, the timer was set for a 24-hr instrument running time. Times of instrument and fan operation relative to shot time are given in Appendix E.

6.5.2 Modifications for Shots 2, 4, and 5. Except for the abandonment of three air sampler stations after Shot 1, Shot 2 operations were basically unchanged from the pretest plans. Two stationary filter heads were put in place of the stack tip air samplers, but they loaded with flyash and were torn during Shot 2.

Shot 4 operations included modifications to the extent of reducing air-sampler filter-paper tracking speeds to make possible a 24-hr sustained run without exhausting the maximum of 200 ft of filter paper in each machine. The two stationary filters at the top of the stack of the YAG 40 were abandoned, and their suction units were used with DMT filters. Adhesive-coated fallout collectors were added to the weatherside instrumentation. In addition, a timer was included in the cubicle-fan circuits of YAG 40, which caused all fans except those of Condition I to shut down within a short time after the samplers stopped.

In preparing for Shot 5, there was not sufficient time to fully instrument the boiler systems. No surface samples were placed in the uptake spaces, and several air samplers in the boiler systems were discontinued for this shot.



## 6.6 ANALYSIS AND RESULTS

Interpretation of much of the continuous-air-sampler data and all of the duct section and surface-sample data depends markedly on the location of the collector relative to the duct system. It is convenient to define here the numbering system employed for identifying the sampling stations for which data will be presented in the following sections. Samples which were not taken from ducts and samples which are better described without numbers will be treated separately.

Figures 6.15 and 6.16 show the locations of continuous air samplers and duct sections in a typical ventilation duct. The presence of an air sampler is indicated by a cone pointing upstream and oriented in the same way as was the shipboard installation. Note that every air-sampler station shown in the figures was not occupied by an air sampler in all the test systems. Reference is made to an air sampler or air-sampler cone collecting from a ventilation duct as "air sampler Condition I - Station 1, YAG 40."

Duct-section dimensions given in the figures measure from the center of the duct sections. Where duct sections are labeled forward, aft, starboard, or port, reference may be made to Figures 6.3 and 6.4 for the orientation of the duct at that sampling station.

Duct sections and surface samples in the boiler-air systems are numbered consecutively. Locations and dimensions are given in Figures 6.17 through 6.19.

Each of the 24 millipore filters listed in Table 6.2 are numbered according to the particle collector from which it was obtained. In addition, a number indicating the particular shot was associated with each sample. Thus, Sample 121-5 would be the molecular filter removed from the high-flow side of the particle collector in the cubicle of Condition I, YAG 40, after Shot 5.

All decay corrections applied to the data presented herein were derived from the beta and gamma decay curves reported in Reference 7. To promote ready comparison among the various types of collectors, all radioactivity measurements were adjusted to the common time of  $S \pm 10$  days.

6.6.1 Analytical Techniques. Special techniques and equipment were developed to analyze the information from the tests in terms of time distribution of airborne activity, average activity per unit volume of air, and deposition of airborne material. Difficulties in analyzing the continuous air-sampler filter-paper strips prevented quantitative results of the time distribution of airborne activity; however, characteristics of the fallout arrival are evident from a comparison of various records of activity versus time. Because quantitative estimate of activity per unit volume of air was not possible from the continuous air-sampler record, the millipore and DMT filters served as the sources for determinations of this quantity.

6.6.1.1 Time Distribution of Airborne Activity, Air-Sampler Graphs. In investigating the time distribution of activity collected on the air-sampler filter strips, it was necessary to design a counting mechanism which would give a continuous record of the activity and have approximately the same resolution as the sampler.

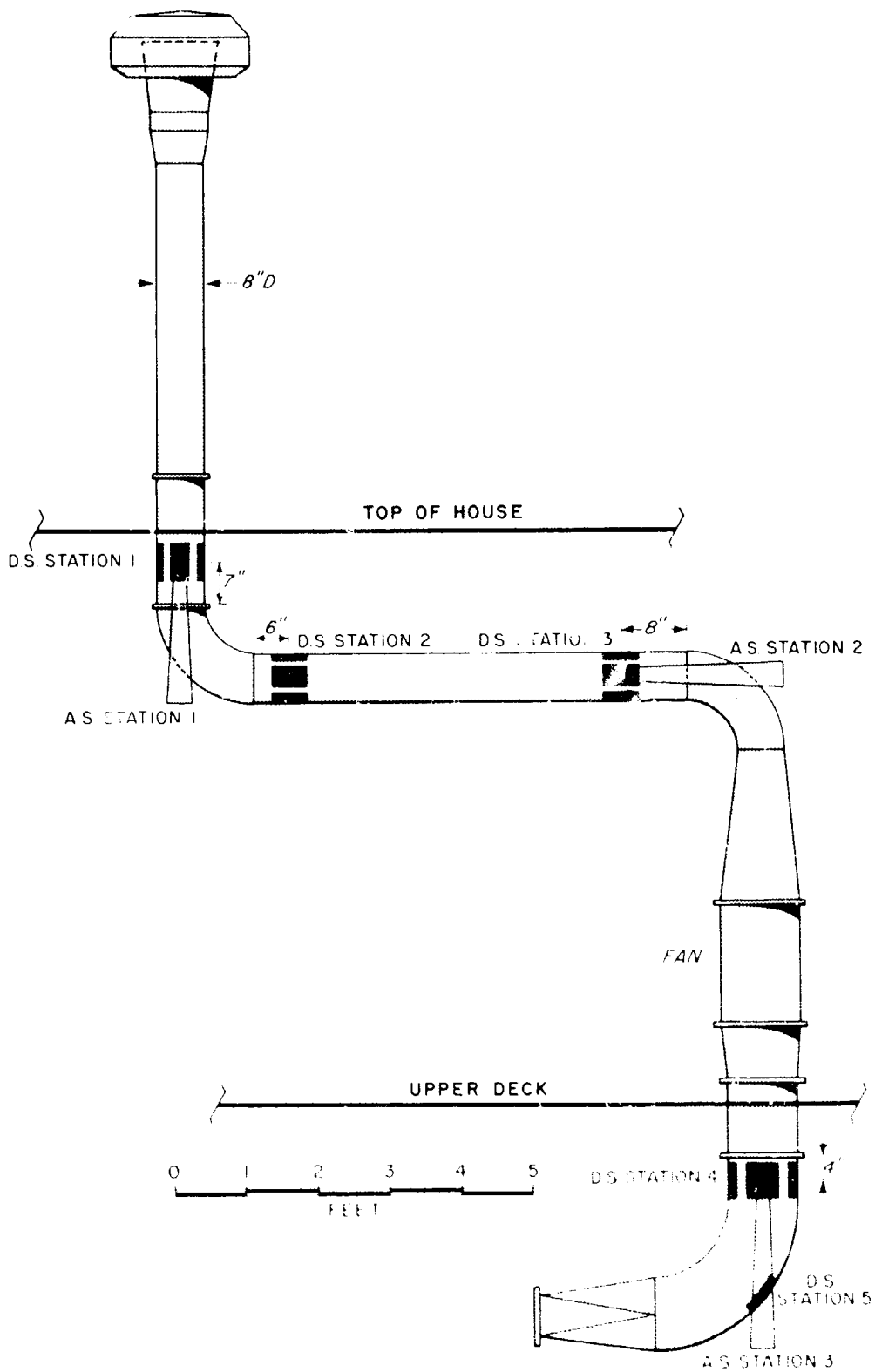

Figure 6.15 Air sampler and duct section sampling stations, Part 1.

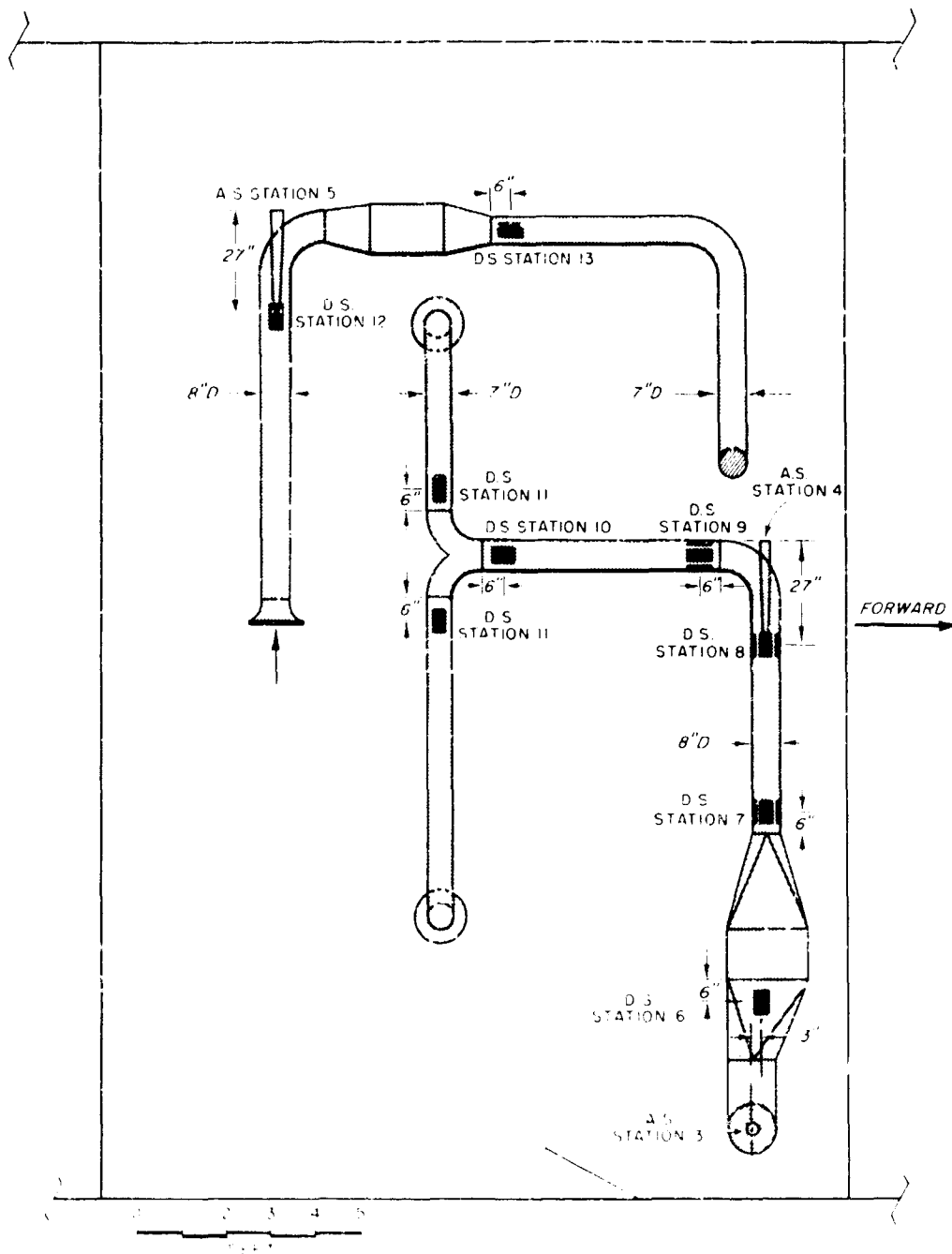

Figure 6.16 Air sampler and duct section sampling stations, Part 2.

The analyzing equipment consisted of two shielded gamma scintillation crystal photomultiplier units, each connected into a UDR-9 scalar. These scalars in turn fed into two rate meters, the combined outputs of which were recorded by an Esterline-Angus recorder. The two gamma scintillation crystals were mounted side by side in a line perpendicular to the motion of the filter-paper strip and its protective cover and were shielded in such a manner as to observe, directly beneath them, an area approximately 6 in. wide and  $3\frac{1}{2}$  in. long. In addition, after passing through the gamma counter, the filter strip and its cover were separated and each was fed through a beta counting arrangement which employed a

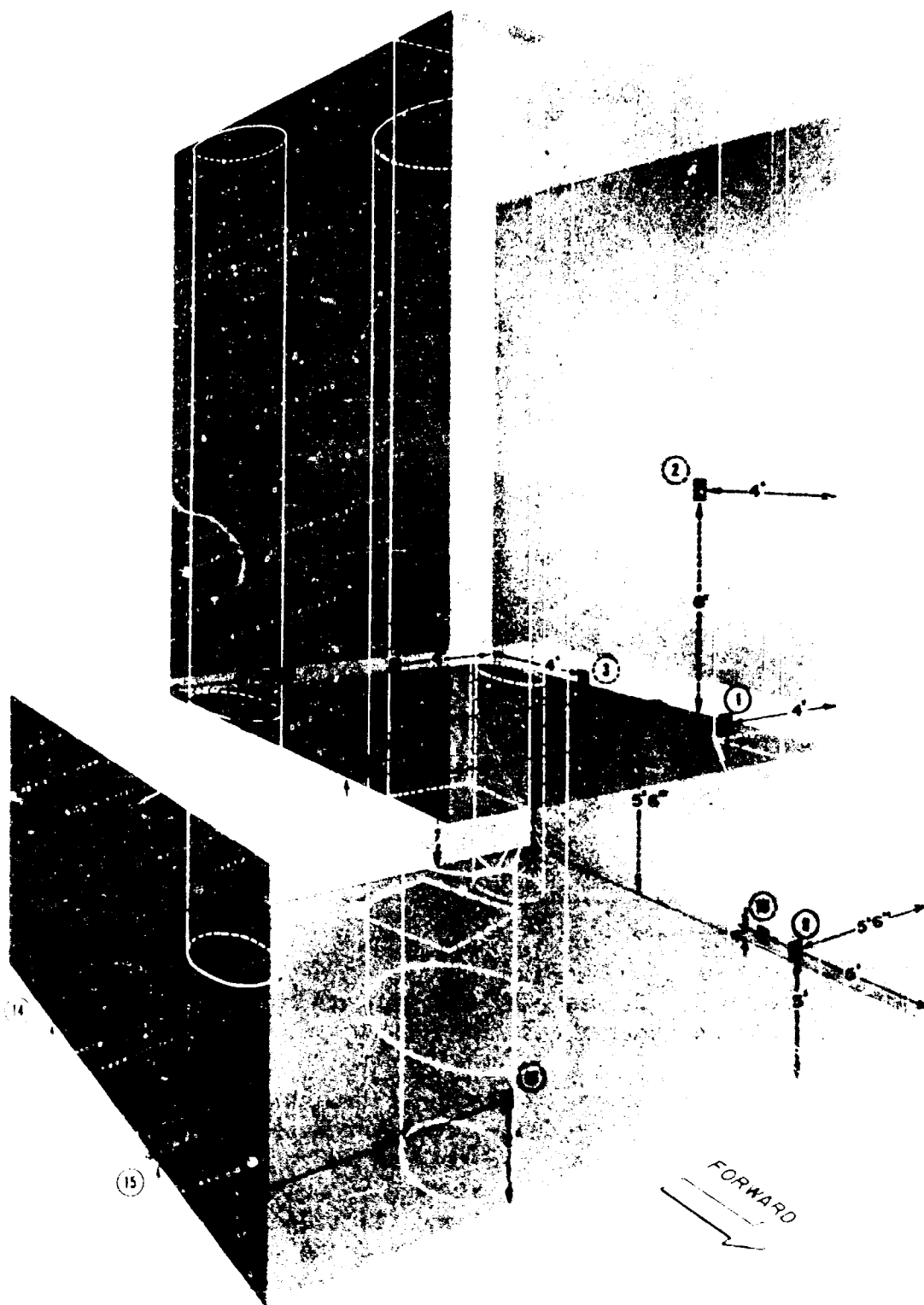

Figure 6.17 Surface sample locations in the uptake space of the YAG 39.

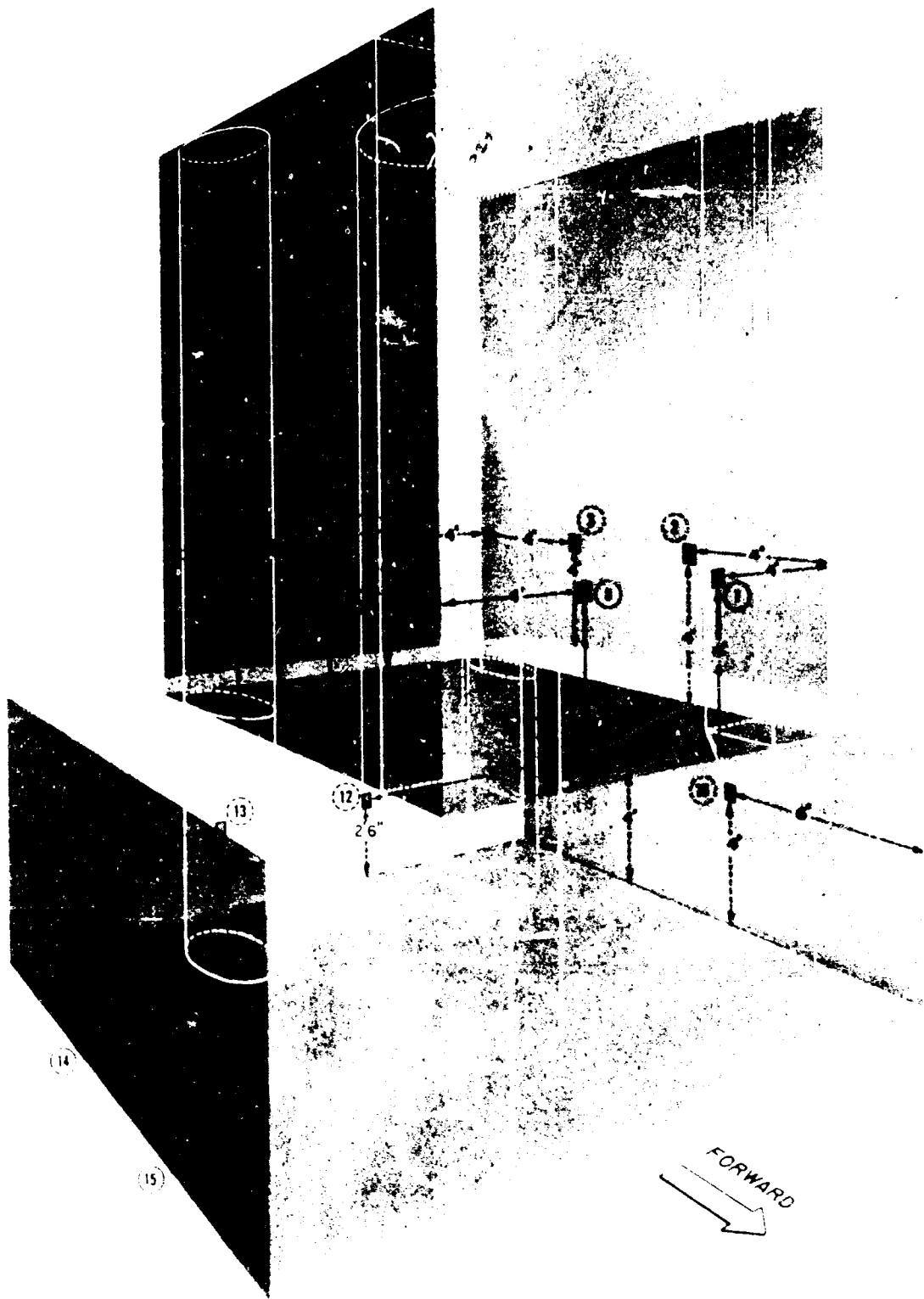

Figure 6.18 Surface sample locations in the uptake space of the YAG 40.

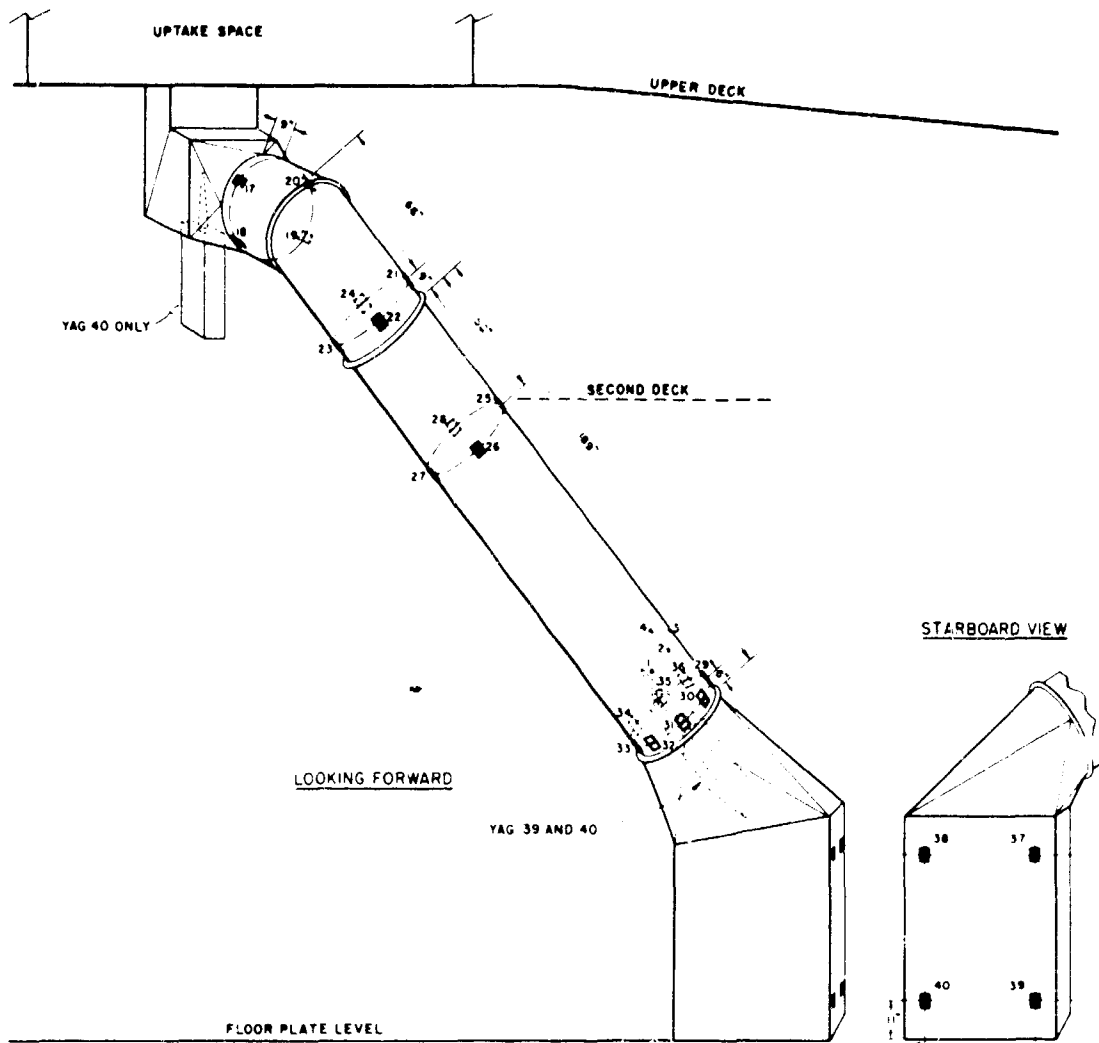

Figure 6.19 Duct section locations in the boiler-air systems of the YAG 39 and YAG 40.

TABLE 6.2 LOCATIONS OF PARTICLE COLLECTORS AND MOLECULAR FILTERS

	Particle Collector No.	High-Flow Millipore	Low Flow Millipore Filter
<b>Ventilation Cubicles</b>			
Condition I, YAG 40	12	121	122
Condition II, YAG 40	2	21	22
Condition III, YAG 40	3	31	32
Condition IV, YAG 40	4	41	42
Condition V, YAG 40	5	51	52
Condition VI, YAG 40	6	61	62
Condition IIA, YAG 39	1	11	12
Top of deckhouse, YAG 40	7	71	72
Top of bridge, YAG 40	8	81	82
Between boilers, fireroom YAG 40	9	91	92
No. 2 Kingpost, YAG 39	10	101	102
Between boilers, YAG 39	11	111	112

gas flow proportional tube<sup>1</sup> in place of a crystal to record the sum of the beta activities on the exposed faces of the filter and its cover-strip. It was intended to eliminate beta absorption by counting both the cover strip and filter paper with two beta proportional counter flow chambers as the papers were unreeled. An additional machine for counting and recording gamma only was used where beta activities were not of interest. A block diagram of the counting set up may be seen in Figure 6.20.

Tests were run to determine the maximum paper speed at which the

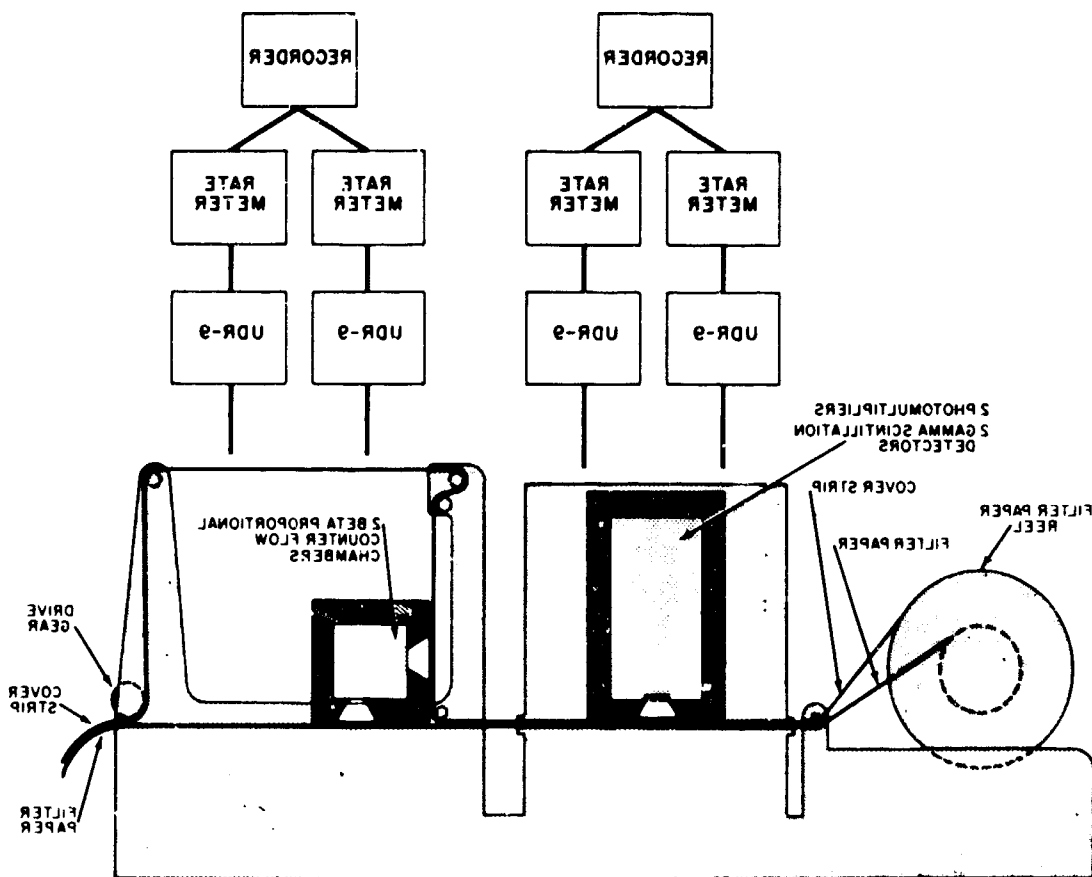

Figure 6.20 Schematic of continuous air-sampler strip analyzer.

rate meter could follow the scalar, and the rate meters were adjusted to give a recorded reading on the Esterline-Angus identical to the counting rate of the scaler. A plot of the counting efficiency as a function of position of activity on the filter strips was made to determine the relationship between the recorded activity and the actual activity.

In operation of the analyzing equipment, three major circumstances contrived to reduce the value of the air-sampler data to a qualitative status. It was difficult to determine which filter strips might have intense hot spots in advance, so no special sequence was selected to preclude possible contamination of the counter. As a result of this, plus the fact that the strips were counted 9 to 16 days after their

<sup>1</sup> Developed by the Nuclear Chemistry Branch at USNRDL.

respective shots when most of them had decayed to an intensity comparable to the background, it was not possible to dissociate background from the plots of activity versus time. The background line attached to each curve is considered an upper limit of the actual background in each case. Specifically, the shape of the activity-versus-time curve below the background upper limit is indeterminate. The parts of each curve in this area have not been removed in order that no suggestion of discontinuity in the activity arrival would be implied.

The rate meters received their pulses from the fourth decade of the scalar, which requires 103 counts to produce a single pulse in the rate meter. Thus, the range of the instrument was set too high, and the majority of the Esterline-Angus traces from the filter strips were less than 10 percent of full scale, except for an occasional hot spot. Finally, a bad connection was discovered between one of the crystals and its scalar long after the strips had been counted and had decayed beyond all further chances of repeating the analysis; a recheck of the rate meters showed that the recorded Esterline-Angus readings were a peculiar unanalyzable function of the memory of their RC circuitry for the activity already passed beyond the range of detection by the crystal and the subsequent activity then within the crystal's range.

A sharp increase in activity was evident at the end of each graph. The time interval over which this increase occurred was directly proportional to the speed of the air-sampler filter strip and corresponded roughly to the time required for the last turn of filter paper on the take-up reel. Since this activity increase obviously resulted from contamination of the outermost layer of filter paper during sample recovery operations, the contaminated section has not been shown on the graphs of activity versus time.

None of the curves obtained from the passage of the strips under the beta probes has been included because the beta data were considered unreliable. The gamma activity records (Figure 6.22 through 6.27) are presented for comparison purposes only. They are not intended to be quantitative. No graphs obtained from Shot 2 are included, because the air samplers shut down shortly after fallout began.

6.6.1.2 Average Activity in Unit Volume of Air, Molecular and DMT Filters. Attempts to measure particle size of the radioactive material in the below-deck spaces failed, because of the low activity on the molecular filters at the time the analysis began. Weatherside millipore filters indicated the presence of various kinds and particulate sizes of radioactive debris. In general, efforts to determine the size range of the radioactive aerosol gaining entrance to the ships' interior produced only the suggestion that the mean particle diameter was of the order of 1  $\mu$  or less.

The molecular filters were counted in a Geiger counter, a gamma scintillation counter and a  $4\pi$ -geometry ionization chamber. The last measurement was to provide a correlation between the scintillation counter and the ionization chamber for the counting of irregular geometries such as cone liners.

The beta counting arrangement consisted of a Tracerlab Model TCG-2 Geiger-Muller tube mounted in a lead castle. The scalar was an IDL Model 161-G. All samples were counted on the second shelf, except



Sample 102-4, which was corrected equivalent to a second shelf count. Absorbers when used were placed on the absorber shelf. The millipore filters were too large (9.0 cm diameter) to count in the beta counter without being folded. Since folding would increase the already significant self-absorption of the samples, small circular pieces were cut from the filters with a cork borer. These pieces were counted and the count extrapolated to the area equivalent to a diameter of 9.0 cm. The pieces counted varied in diameter from 0.453 cm to 2.13 cm. The smaller samples were cut from the highly active millipore filters taken from the weather-side stations. Since the ratios between the area of the full-size molecular filters and the counted samples varied between 18 and 390, it is possible that considerable error may have been introduced in adjusting the counts to an area equivalent to the original filter. However, radioautographs indicated rather uniform dispersal of activity over the filter faces. Unfortunately, the rapidly decaying samples did not allow time for the counting multiple samples from a single filter.

By the time beta counting of molecular filters had begun, the samples obtained from Shot 2 had decayed to background. As a result, no estimates of average beta concentrations are included for Shot 2.

Gamma counts of the molecular filters were obtained by placing the entire filter on the floor of a lead castle directly beneath the scintillation crystal. These counts were for intercomparison among the molecular filters and for comparison with other samples.

DMT filters were sublimed at reduced pressure, leaving a residue of material that had been collected during the field sampling (Reference 18). The bulk of the residue was oil from the Shot 4 sample and soot or flyash from the Shot 5 collection.

The gamma ionization chamber used for counting these samples presented nearly a  $4\pi$  geometry to the test tube containing the residue. A tube of slightly larger diameter than the test tube extended into the body of the ionization chamber so that the only direction not sensitive to the sample's radiation was that of the entrance tube. Activity was measured in millivolts. Since it was intended to compare the DMT filter residue counting rate with the gamma count rates of the molecular filters, the gamma ionization counter was calibrated against the gamma scintillation counter. It was necessary to assume that fractionation was negligible within the vicinity of the YAG 40. Several molecular filters were counted in both the ionization chamber and the scintillation counter so that scintillation counts per second could be plotted against millivolts (Figure F.14, Appendix E).

Estimates of the total volume of air drawn through the molecular and DMT filters were made on the basis of the flow record taken from the suction unit associated with each of the collections (see Appendix E).

6.6.1.3 Deposition of Airborne Material: Duct Sections and Cone Liners. The scintillation gamma counter (Figure 6.21) referred to above was composed of a shielded gamma scintillation crystal photomultiplier unit connected to a UDR-9 scalar. The crystal could "see" a circle  $7\frac{1}{2}$  in. in diameter, which included all the surface of the duct sections. In tests to determine the counting efficiency as a function of position, it was found that the efficiency fell off with distance from the center to a minimum of 65 percent of that at the center for

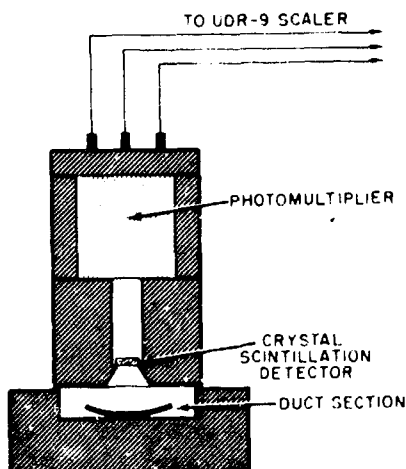

Figure 6.21 Scintillation gamma counter.

the extreme corners when the sample rested on the floor of the castle.

All duct sections and plates from the boiler-air intake were counted at the laboratory 12 to 18 days after each shot. This delay yielded relatively low readings on all samples, with the boiler-air plates being very close to background. After all the samples were counted, values were corrected for decay to a common date of 5410 days for purposes of comparison.

Each copper foil cone liner was rolled into a cylinder 3 in. long, placed in a plastic test tube, and counted in the ionization chamber described earlier. The resulting values in millivolts were transposed into counts per minute by use of a calibration curve.

One cone liner, taken from the weatherside air sampler above the deckhouse of YAG 40 after Shot 5, was divided into a number of small pieces, each of which was counted under the Geiger tube; a plot was made of activity versus position on the liner (see Appendix E).

#### 6.6.2 Results of Measurements in the Ventilation Systems.

Measurements in the ventilation systems gave evidence on the concentration of airborne activity in them, the effectiveness of ventilation countermeasures, and the extent to which airborne material was deposited in the systems.

6.6.2.1 Concentration of Airborne Activity. Characteristics of fallout arrival in Condition II, YAG 40, for Shots 4 and 5 may be seen in Figures 6.22 and 6.23. A gradual decrease in activity occurs between Station 1, directly beneath the mushroom intake, and Station 5, in the cubicle exhaust. The shape of the curve of activity versus time is maintained throughout the duct for both shots. The differences in time occurrence of a particular activity peak at various locations in the duct probably result from irregular stretching of the filter strip during sampling and analysis. The smoother appearance of the curves taken from Stations 3 to 5 is caused by the slower filter-paper speed in the samplers at those stations (see Appendix E).

These curves indicate that the concentration of radioactivity in the air did not change appreciably during the time the air samplers were operating, that is, until about midnight of the shot day. Decay effects were significant during fallout, however, as may be seen in the

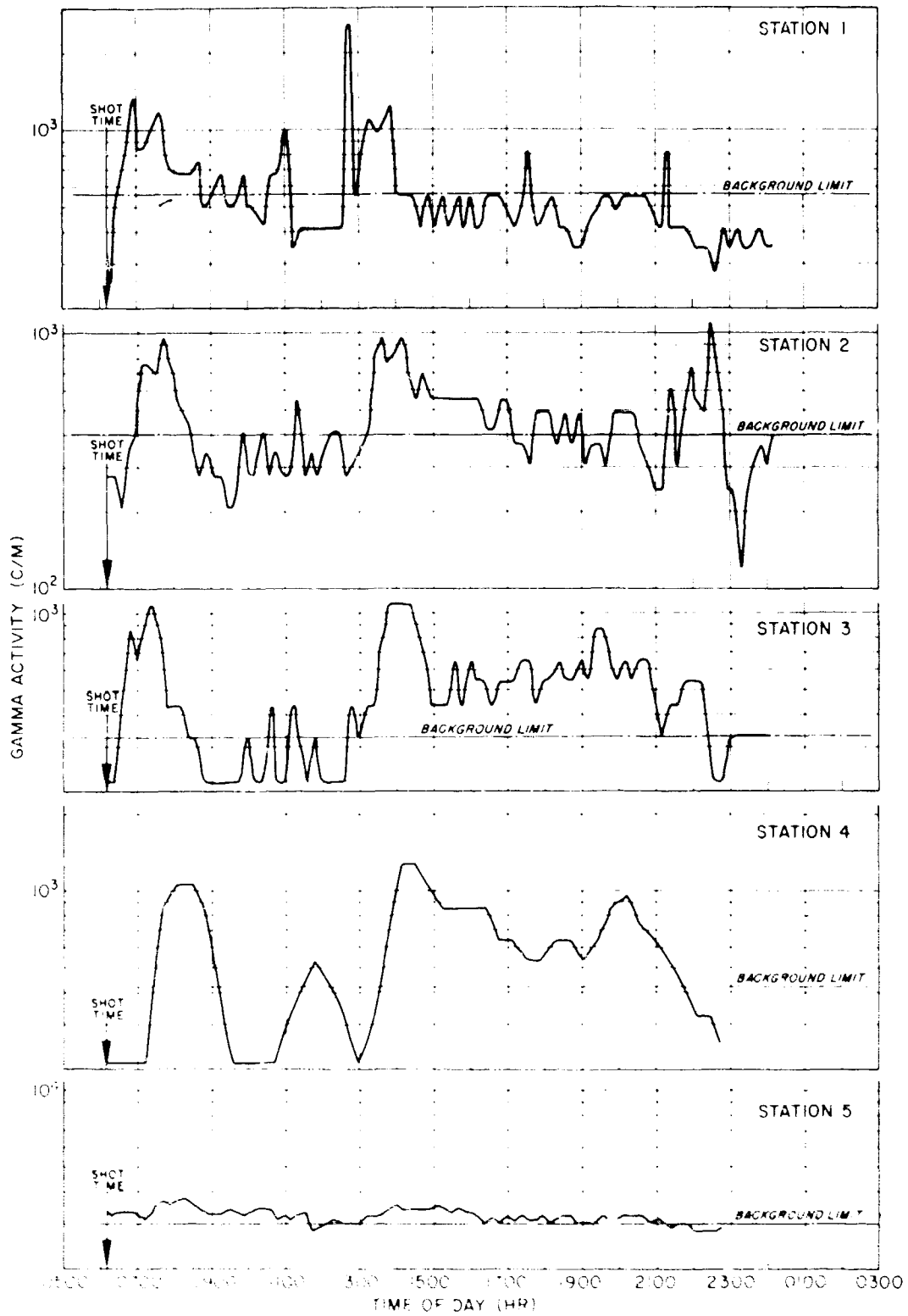

Figure 6.22 Comparison of activity concentrations as a function of time at S+10 days for Condition II, YAG 40, at Shot 4.

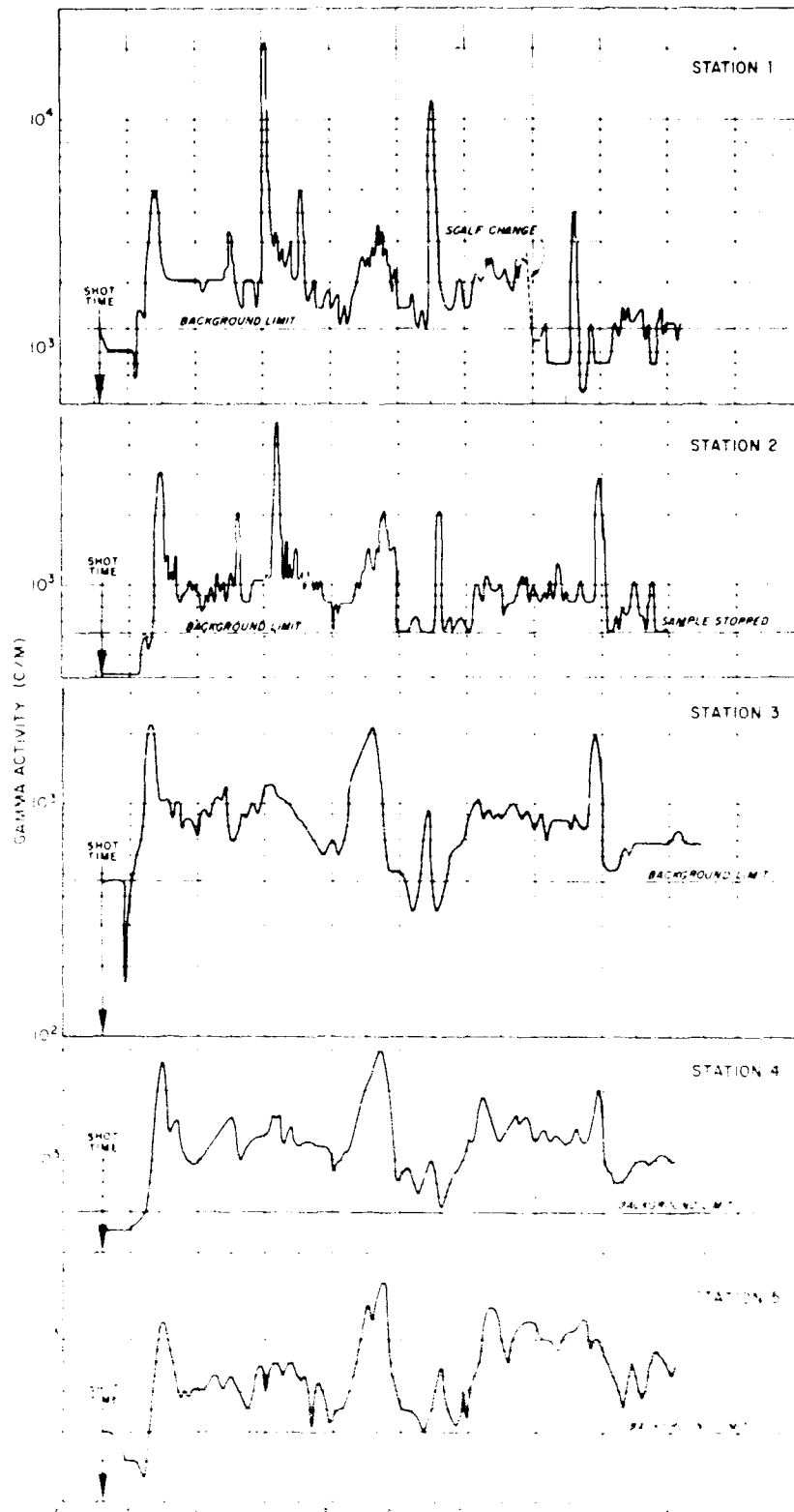

Figure 6.23 Comparison of activity concentrations as a function of time at S+10 days for Condition II, YAG 40, at Shot 5.

difference between a single curve corrected to S+10 days and corrected point by point to time of arrival of activity (Figure E.7, Appendix E).

Total beta activities found on the molecular filters from the test cubicles are given in Table 6.3 for Shots 4 and 5. The separate count

TABLE 6.3 BETA COUNT RATES OF THE MOLECULAR FILTERS  
IN THE VENTILATION SPACES FOR SHOTS 4 AND 5

Cubicle	Shot 4		Shot 5	
	Sample Numbe. β counts per minute corrected for decay to 10 days, corrected to a diameter of 9.0 cm	Sum of counts on high flow and low flow heads= total β c/m of the parti- cle collector at S+10 days	β counts per minute corrected for decay to 10 days, corrected to a diameter of 9.0 cm	Sum of counts on high flow and low flow heads= total β c/m of the parti- cle collector at S+10 days
Condition IIA, YAG 39	11 42.1 x 10 <sup>3</sup>	46.5 x 10 <sup>3</sup>	32.9 x 10 <sup>3</sup>	72.4 x 10 <sup>3</sup>
	12 4.43 x 10 <sup>3</sup>		39.6 x 10 <sup>3</sup>	
Condition I, YAG 40	121 160 x 10 <sup>3</sup>	172 x 10 <sup>3</sup>	622 x 10 <sup>3</sup>	644 x 10 <sup>3</sup>
	122 12.3 x 10 <sup>3</sup>		21.6 x 10 <sup>3</sup>	
Condition II, YAG 40	21 143 x 10 <sup>3</sup>	159 x 10 <sup>3</sup>	490 x 10 <sup>3</sup>	517 x 10 <sup>3</sup>
	22 163 x 10 <sup>3</sup>		26.9 x 10 <sup>3</sup>	
Condition III, YAG 40	31 107 x 10 <sup>3</sup>	114 x 10 <sup>3</sup>	454 x 10 <sup>3</sup>	480 x 10 <sup>3</sup>
	32 6.97 x 10 <sup>3</sup>		25.7 x 10 <sup>3</sup>	
Condition IV, YAG 40	41 -	-	14.2 x 10 <sup>3</sup>	14.2 x 10 <sup>3</sup>
Condition V, YAG 40	51 239 x 10 <sup>3</sup>	245 x 10 <sup>3</sup>	599 x 10 <sup>3</sup>	632 x 10 <sup>3</sup>
	52 6.60 x 10 <sup>3</sup>		32.6 x 10 <sup>3</sup>	
Condition VI, YAG 40	61 3.2 x 10 <sup>3</sup>	7.76 x 10 <sup>3</sup>	6.85 x 10 <sup>3</sup>	8.22 x 10 <sup>3</sup>
	62 4.6 x 10 <sup>3</sup>		1.37 x 10 <sup>3</sup>	

rates of the high-flow and low-flow filters are also included.

The gamma count rates of the same molecular filters, plus the gamma count rates of molecular filters exposed during Shot 2, are presented in Table 6.4.

Sample 42 is missing from the table, because the low-flow collecting head of particle Collector 4 was damaged prior to Shot 2. Subsequently, the low-flow head was closed off, and all the sampled air was drawn through the high-flow head. Since the suction unit for particle Collector 4 failed during the run on Shot 2, not enough air was sampled to permit the collection of a measurable quantity of radioactive material.

Each of the suction units associated with molecular filter collectors and continuous air samplers was equipped with a flow recorder. The air drawn through each particle collector between the time of start of fall-out and the time of pump shut off has been estimated on the basis of these records (see Appendix E). With these values and the total beta and gamma counts of the molecular filters, the average activity has been derived, Table 6.5.

The average specific activity in the test cubicles for Shot 2 are considerably higher than the corresponding values for the remaining two

TABLE 6.4 GAMMA COUNT RATES OF THE MOLECULAR FILTERS IN THE VENTILATION SPACES FOR SHOTS 2, 4 AND 5

Cubicle	Sample Number	Shot 2		Shot 4		Shot 5	
		7 c/m corrected for decay to S+10 days	Sum of counts on high flow and low flow heads = total 7 c/m per particle collector	7 c/m corrected for decay to S+10 days	Sum of counts on high flow and low flow heads = total 7 c/m per particle collector	7 c/m corrected for decay to S+10 days	Sum of counts on high flow and low flow heads = total 7 c/m per particle collector
Condition IIA, YAG 39	11	$0.346 \times 10^3$	$0.367 \times 10^3$	$1.28 \times 10^3$	$1.35 \times 10^3$	$0.903 \times 10^3$	$1.56 \times 10^3$
	12	$0.019 \times 10^3$		$0.072 \times 10^3$		$0.657 \times 10^3$	
Condition I, YAG 40	121	$3.21 \times 10^3$	$1.78 \times 10^3$	$3.03 \times 10^3$	$3.16 \times 10^3$	$6.51 \times 10^3$	$6.96 \times 10^3$
	122	$0.279 \times 10^3$		$0.137 \times 10^3$		$0.446 \times 10^3$	
Condition II, YAG 40	21	$3.05 \times 10^3$	$3.37 \times 10^3$	$2.16 \times 10^3$	$2.26 \times 10^3$	$2.30 \times 10^3$	$2.70 \times 10^3$
	22	$0.327 \times 10^3$		$0.099 \times 10^3$		$0.400 \times 10^3$	
Condition III, YAG 40	31	$5.59 \times 10^3$	$5.86 \times 10^3$	$2.20 \times 10^3$	$2.26 \times 10^3$	$5.37 \times 10^3$	$5.64 \times 10^3$
	32	$0.270 \times 10^3$		$0.064 \times 10^3$		$0.268 \times 10^3$	
Condition IV, YAG 40	41	$0.327 \times 10^3$	$0.326 \times 10^3$	-	-	$0.222 \times 10^3$	$0.222 \times 10^3$
Condition V, YAG 40	51	$1.12 \times 10^3$	$1.21 \times 10^3$	$3.17 \times 10^3$	$3.32 \times 10^3$	$4.63 \times 10^3$	$5.00 \times 10^3$
	52	$0.085 \times 10^3$		$0.152 \times 10^3$		$0.369 \times 10^3$	
Condition VI, YAG 40	61	$0.370 \times 10^3$	$1.37 \times 10^3$	$0.117 \times 10^3$	$0.120 \times 10^3$	$0.128 \times 10^3$	$0.175 \times 10^3$
	62	$0.996 \times 10^3$		$0.0034 \times 10^3$		$0.047 \times 10^3$	

TABLE 6.5 ACTIVE AEROSOL CONCENTRATIONS IN BELOW-DECK VENTILATION SPACES FOR THREE SHOTS

Cubicle	Shot 2		Shot 4		Shot 5		
	7 c/m/ft <sup>3</sup> of air at S+10 days	7 c/m/ft <sup>3</sup> of air at S+10 days	7 c/m/ft <sup>3</sup> of air at S+10 days	Lower limit of d/m/ft <sup>3</sup> of air at S+1 day (a)	7 c/m/ft <sup>3</sup> of air at S+10 days	7 c/m/ft <sup>3</sup> of air at S+10 days	Lower limit of d/m/ft <sup>3</sup> of air at S+1 day (a)
Condition I (0/0 cfm)	2.45	0.33	18.2	$1.95 \times 10^3$	0.72	66.7	$11.6 \times 10^3$
Condition II (1000 cfm)	5.53	0.22	15.5	$1.66 \times 10^3$	0.28	54.2	$9.38 \times 10^3$
Condition III (no fans)	7.44	0.20	9.8	$1.05 \times 10^3$	0.49	41.9	$7.26 \times 10^3$
Condition IV (precipitron installation)	0.42	-	-	-	0.018	1.16	$0.20 \times 10^3$
Condition V (mesh filter)	1.43	0.26	17.3	$2.07 \times 10^3$	0.42	53.2	$9.21 \times 10^3$
Condition VI (paper filter)	2.04	0.011	0.73	$0.076 \times 10^3$	0.017	2.78	$0.135 \times 10^3$
Condition IIA (YAG 39 washdown comparison)	-	0.37	7.6	$0.81 \times 10^3$	0.13	5.82	$1.01 \times 10^3$

(a) These values were obtained by multiplying the lower limit of air at S+10 days by a constant factor of 0.3 (Appendix B for derivation) and correcting the resulting figures for decay to S+1 day.

shots. There are two possible reasons for this irregularity. First, the sampling instruments shut down before the fallout reached maximum intensity. Although the particle collectors had stopped drawing air through the filters, the filter faces were still exposed to material thrown against them<sup>1</sup> by the intake duct diffusers and to airborne particulate matter settling on them. Consequently, the quotient of total counts per minute divided by total cubic feet of air sampled was exaggerated. Secondly, the average activity derived for Shots 4 and 5 was estimated from the same ratio, but the total volume of air sampled was much larger because of the longer sampling time. If the activity concentrations were considerably lower at later times than at the beginning of fallout, the average values for Shots 4 and 5 would be reduced from an average derived from a collection made over a period of 1 or 2 hours from the beginning of fallout. The continuous air samples do not support this latter possibility, and poor efficiencies during Shot 2 of Conditions IV and VI (Table 6.6) favor the former mechanism. Inconsistencies are evident when a comparison is made of total activities in the cubicles for different shots (Tables 6.3 and 6.4); total activity available to the collectors is not known, and time of complete cessation of airborne activity in the cubicles is unknown. Therefore, it is not possible to deduce the primary mechanism responsible for the deviations of Shot 2 activity concentrations. While it is feasible to compare cubicle activity concentrations for the same shot, a comparison of activity concentrations in the same cubicle for Shots 2 and 4 or Shots 2 and 5 is uncertain.

6.6.2.2 Effectiveness of Ventilation Countermeasures. Figures 6.24 through 6.27 depict the relative occurrence of airborne activity in the exhaust-duct samplers for Shots 4 and 5. Note the almost complete absence of the 1430 activity peak for Shot 5 in all but Conditions II and V. This peak is characteristic of all the Condition II stations (Figure 6.23). Reference to Figure 6.27, a comparison of Station 1 activity levels in Conditions I, II (YAG 40) and Condition IIA (YAG 39) indicates that a small 1430 peak occurs in Condition I.

It is also interesting that the concentration of activity in Conditions V and VI, YAG 40, slowly increases with time for Shot 5.

An evaluation of the various geometries and protective mechanisms can be made from the results in Table 6.5. Condition II, the unprotected 1,000 cfm system on YAG 40, was the standard against which the other systems were compared. In Table 6.6, the average beta and gamma count rates for Condition II have been normalized to 1.0, thereby allowing the average values of activity in the other test conditions to be presented in terms of percentages of Condition II values.

A comparison is not made between Condition II, YAG 40, and Condition IIA, YAG 39, the washdown countermeasure. Although the two ships were close together during the Shot 4 and Shot 5 tests, there is evidence that there were significant differences in total exposure of the ships to fallout.

It is evident that the airborne radioactivity in Condition II, YAG 40, is characteristically less than that in Conditions I, III and V.

---

<sup>1</sup>Fans continued to run for some time after instruments shut off during Shot 2.

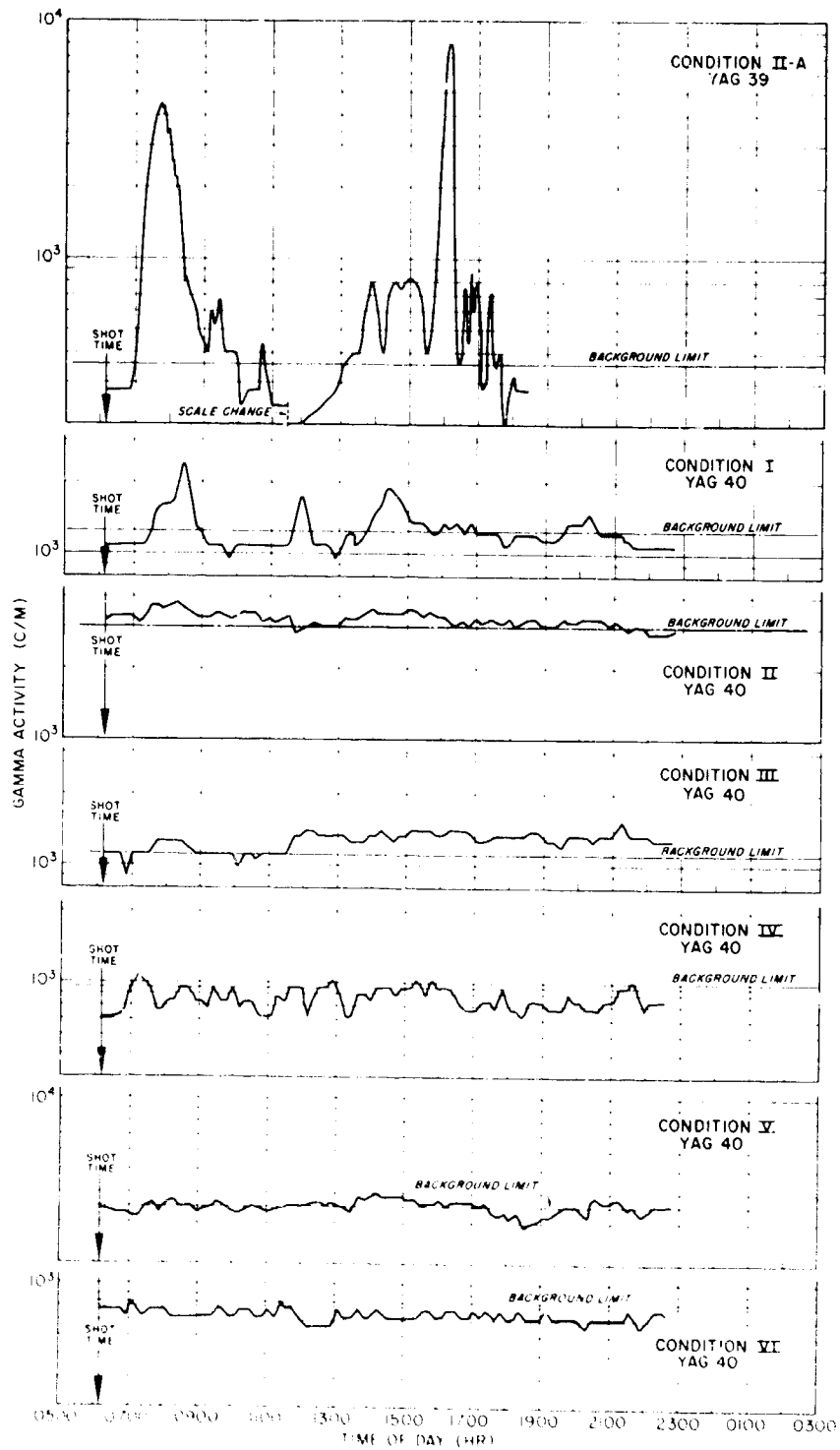

Figure 6.24 Comparison of Station 5 activity concentrations at Shot 4 as a function of time at S:10 days for the seven conditions.



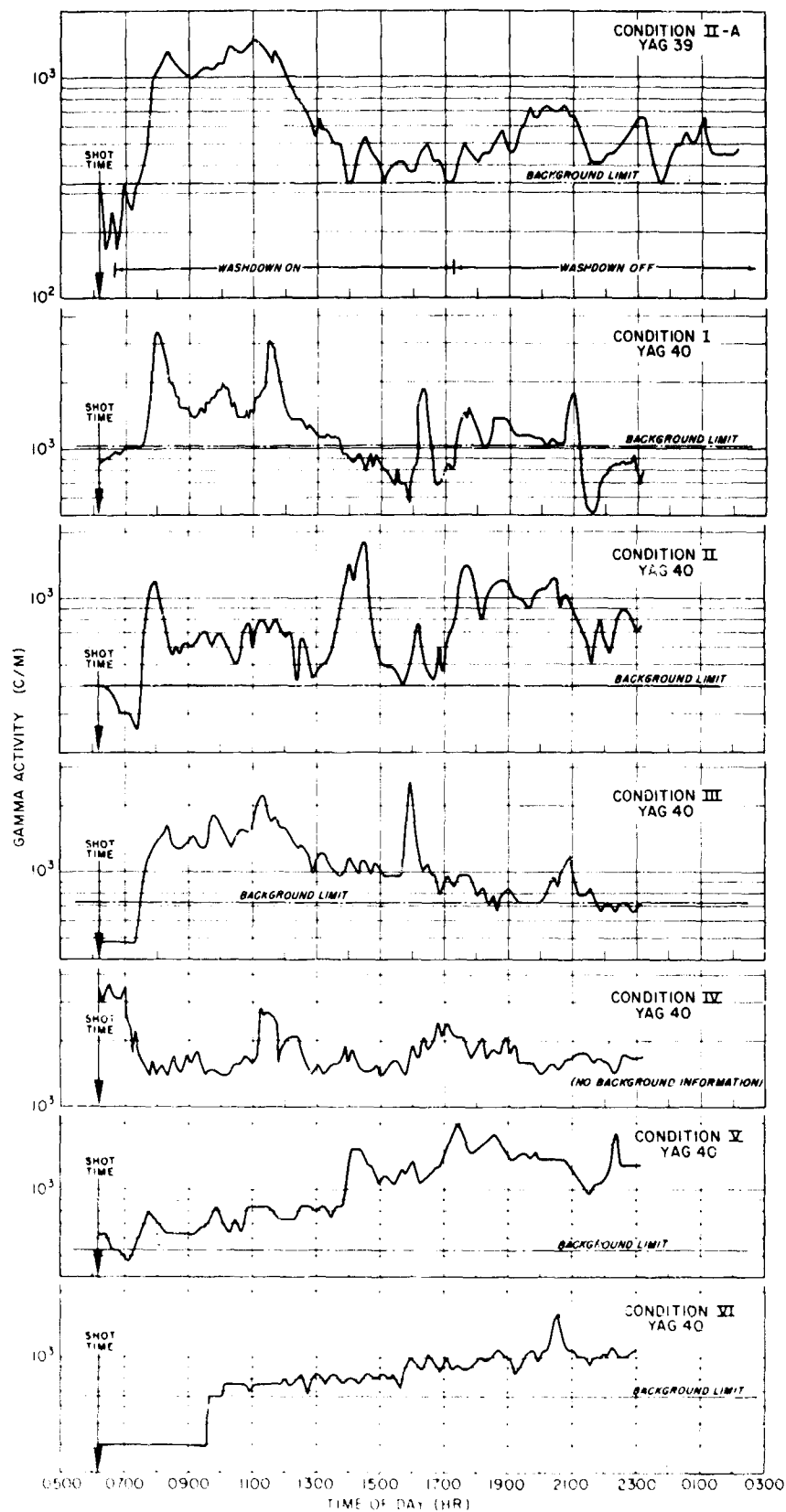

Figure 6.25 Comparison of Station 5 activity concentrations at Shot 5 as a function of time at S+10 days for the seven conditions.

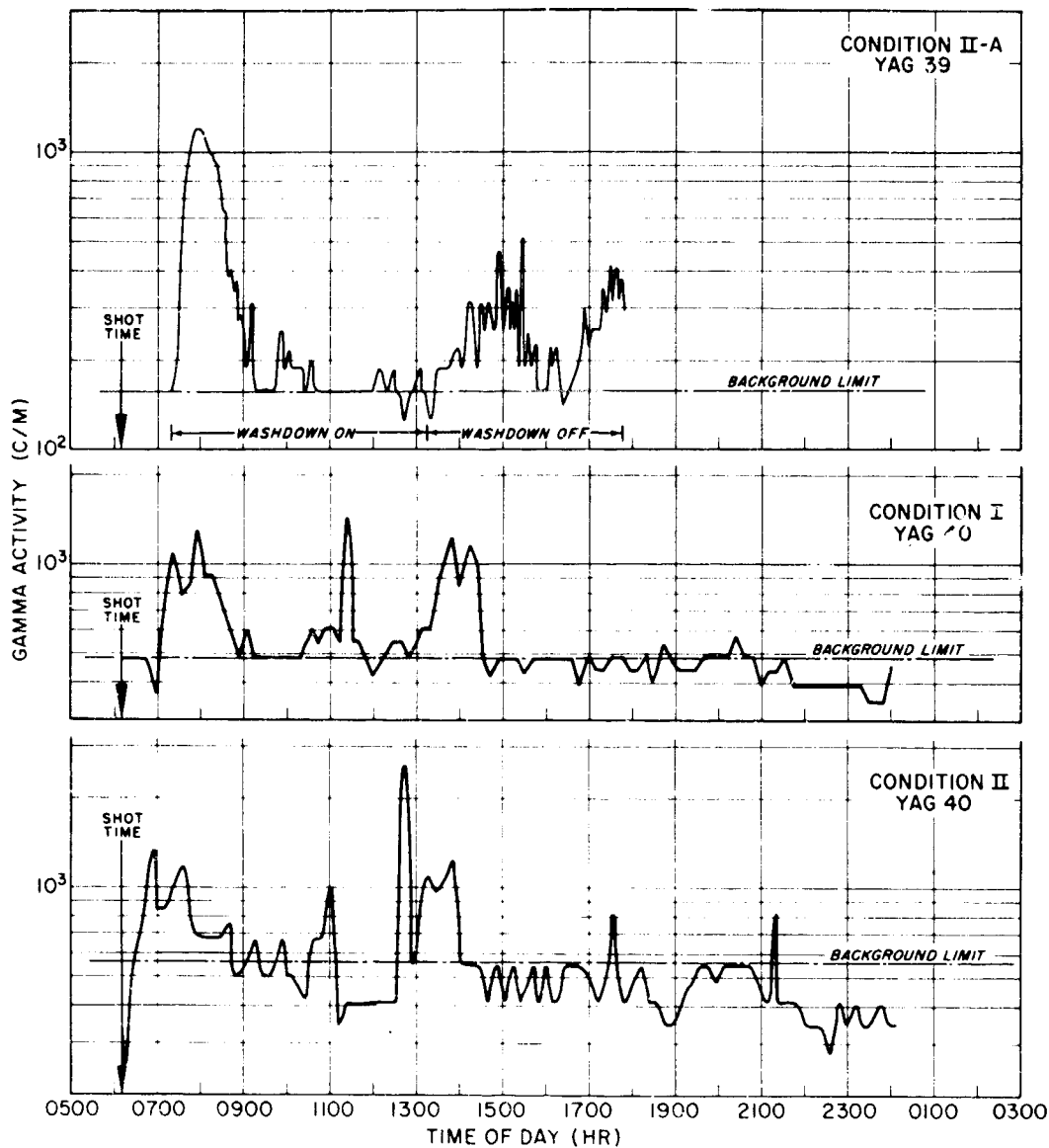

Figure 6.26 Comparison of Station 1 activity concentrations at Shot 4 as a function of time at 8+10 days for Conditions I, II, IIA.

The excess of continuous air sampler cones in the duct elbows must have themselves constituted the third best countermeasure against the ingress of airborne activity. In general, no significant reduction in the concentration of airborne activity was obtained by reducing the flow rate or by introducing a coarse-screen filter into the ventilation duct system. It is not known to what extent the particle sizes of the airborne material and the shape of the duct intakes influenced this result.

6.6.2.3 Deposition of Airborne Material. Results of activity measurements on the cone liners are given in Table 6.7. Values are presented in terms of gamma counts per minute, at 8 + 10 days. There is not sufficient accuracy in the significant figures to warrant a comparison among the test cubicles for evaluating the countermeasures. The more important circumstance is that the mechanism of deposition

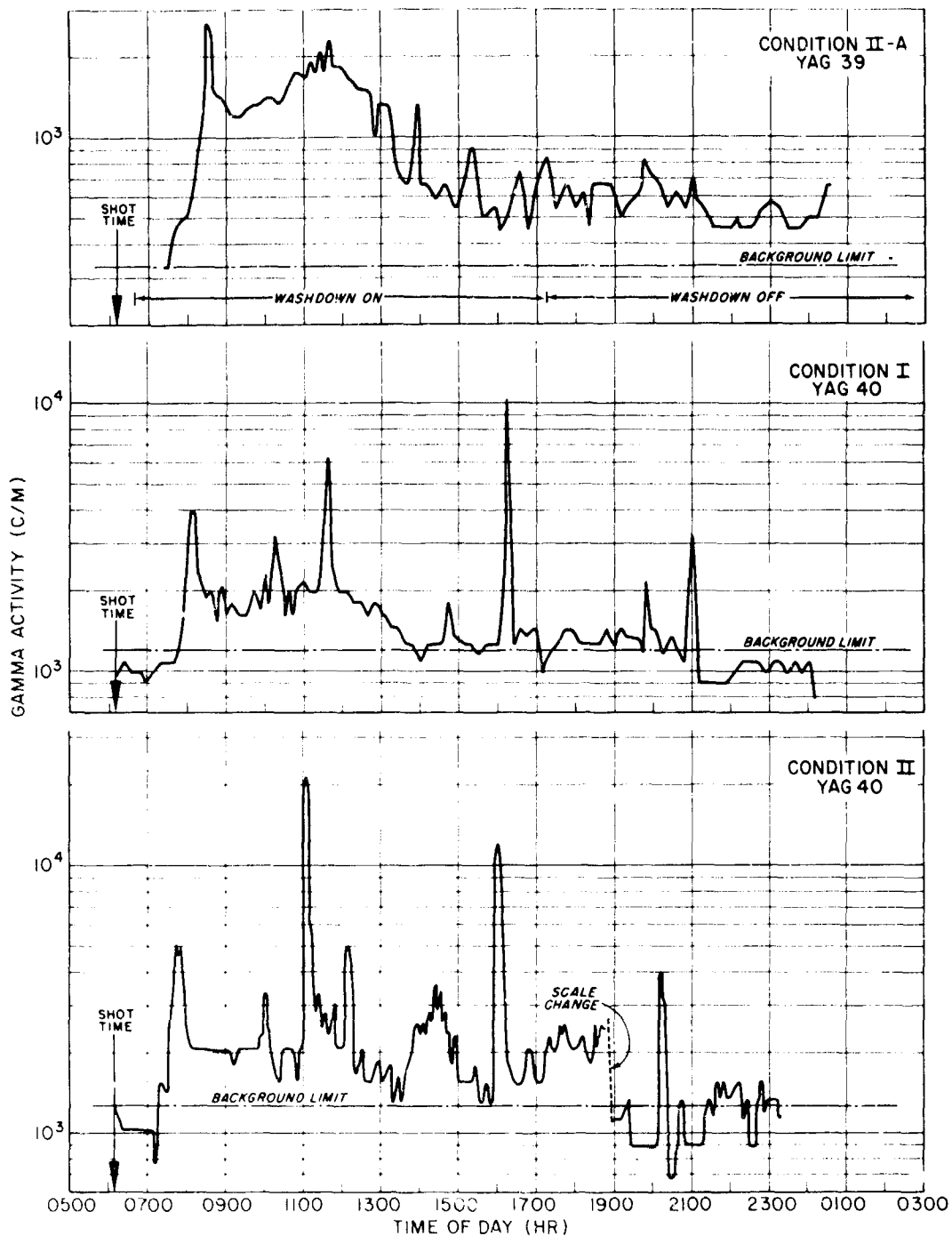

Figure 6.27 Comparison of Station 1 activity concentrations at Shot 5 as a function of time at S+10 days for Conditions I, II, and IIA.

inside the cone is too uncertain to allow a comparison among cone liners without a knowledge of the quantitative collection made by the corresponding air-sampler filter strips.

Data are presented in the bar graphs, Figures 6.28 through 6.34, for the duct sections taken from the ventilation ducts. Station numbers (Figures 6.15 and 6.16) are reproduced along the bottom of each chart and again at the top beneath a schematic line drawing of the particular duct system. This method permits an approximate visual relationship

TABLE 6.6 COMPARISON OF AEROSOL CONCENTRATIONS  
IN THE TEST CUBICLES FOR THREE SHOTS

Cubicle	Shot 2	Shot 4		Shot 5	
	$\frac{\gamma}{\text{c/m/ft}^3} \times 100$ $\frac{\gamma}{\text{c/m/ft}^3}$ in Cond. II YAG 40	$\frac{\gamma}{\text{c/m/ft}^3} \times 100$ $\frac{\gamma}{\text{c/m/ft}^3}$ in Cond. II YAG 40	$\frac{\beta}{\text{c/m/ft}^3} \times 100$ $\frac{\beta}{\text{c/m/ft}^3}$ in Cond. II YAG 40	$\frac{\gamma}{\text{c/m/ft}^3} \times 100$ $\frac{\gamma}{\text{c/m/ft}^3}$ in Cond. II YAG 40	$\frac{\beta}{\text{c/m/ft}^3} \times 100$ $\frac{\beta}{\text{c/m/ft}^3}$ in Cond. II YAG 40
Condition I, YAG 40	44%	150%	117%	257%	123%
Condition II, YAG 40	100%	100%	100%	100%	100%
Condition III, YAG 40	135%	91%	63%	175%	77%
Condition IV, YAG 40	7.6%	-	-	6.4%	2.1%
Condition V, YAG 40	27%	118%	125%	150%	98%
Condition VI, YAG 40	37%	5.0%	4.7%	6.1%	1.4%

TABLE 6.7 GAMMA COUNTS OF CONE LINERS IN VENTILATION SYSTEMS FOR THREE SHOTS

Location of Cone Liner from Air Sampler	Overall Length of Cone liner (in.)	Shot 2	Shot 4	Shot 5
		$\gamma$ Counts per minute at S+10 days	$\gamma$ Counts per minute at S+10 days	$\gamma$ Counts per minute at S+10 days
Station 1 Condition IIA, YAG 39	29.5	$0.110 \times 10^3$	$0.419 \times 10^3$	$2.84 \times 10^3$
Station 5 Condition IIA, YAG 39	29.5	$0.027 \times 10^3$	$2.61 \times 10^3$	$0.270 \times 10^3$
Station 1 Condition I, YAG 40	27.5	$1.35 \times 10^3$	$0.623 \times 10^3$	$6.94 \times 10^3$
Station 5 Condition I, YAG 40	27.5	$0.525 \times 10^3$	$0.366 \times 10^3$	$4.21 \times 10^3$
Station 1 Condition II, YAG 40	29.5	$3.84 \times 10^3$	$1.39 \times 10^3$	$8.94 \times 10^3$
Station 2 Condition II, YAG 40	29.5	$3.09 \times 10^3$	$1.58 \times 10^3$	$7.64 \times 10^3$
Station 3 Condition II, YAG 40	25	$1.03 \times 10^3$	$0.458 \times 10^3$	$5.10 \times 10^3$
Station 4 Condition II, YAG 40	29.5	$8.85 \times 10^3$	$0.685 \times 10^3$	$5.39 \times 10^3$
Station 5 Condition II, YAG 40	29.5	$1.49 \times 10^3$	$0.189 \times 10^3$	$3.21 \times 10^3$
In cubicle Condition III, YAG 40	4 (cone stub)	$0.747 \times 10^3$	$0.259 \times 10^3$	$0.871 \times 10^3$
Station 5 Condition IV, YAG 40	29.5	$0.804 \times 10^3$	$0.259 \times 10^3$	$3.43 \times 10^3$
Station 5 Condition V, YAG 40	29.5	$1.29 \times 10^3$	$0.530 \times 10^3$	$2.62 \times 10^3$
Station 5 Condition VI, YAG 40	29.5	$2.03 \times 10^3$	$0.325 \times 10^3$	$7.13 \times 10^3$

between each measurement and its location in the duct. The counting rates shown in the figures apply to a contaminated area 4 by 6 inches.

In some instances where an individual ventilation-duct section has a very high counting rate compared to its immediate neighbors (particularly the bottom duct section, Station 2, Condition II, YAG 40, Shot 4), the circumstance may be attributed to liquid runoff leaving an active deposit behind.

As a rule, activity levels of deposited material do not decrease appreciably from the entrance to the exit of each complete duct system. An increase in deposited activity is evident in most of the graphs near

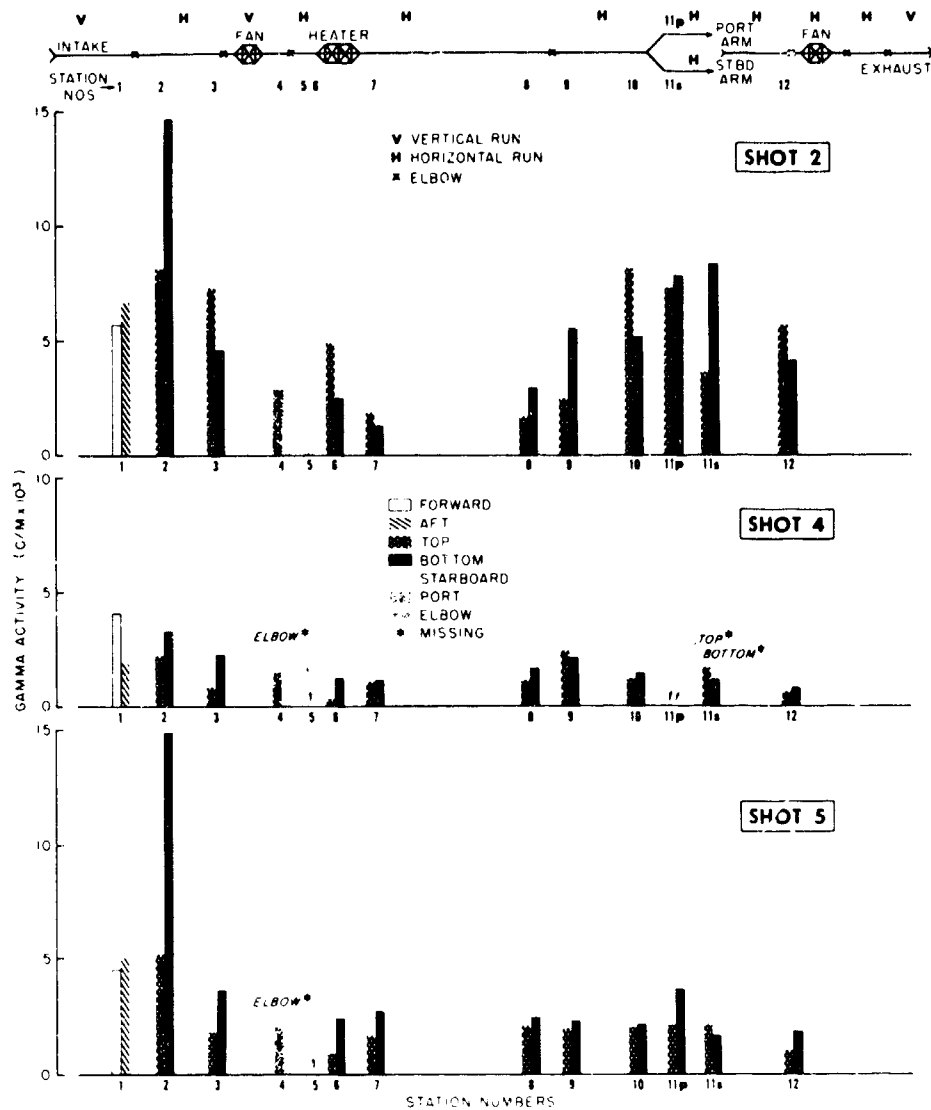

Figure 6.28 Duct section activities at S+10 days for three shots, Condition I, YAG 40.

the region of the supply duct wye branches.

**6.6.3 Results of Measurements in Boiler Systems.** Measurements in the boiler systems yielded values for the concentration of airborne activity there, as well as for the amounts of airborne material deposited

**6.6.3.1 Concentration of Airborne Activity.** Only three charts of activity versus time (Figure 6.35) were obtained from the boiler systems of the ships, and all were from Shot 4. From the curves, activity concentrations in the fireroom of YAG 40 appear negligible. The unusual apparent increase in activity after 1300 for the YAG 39 situation is not interpretable, since data obtained from the other instruments are not consistent with such an increase. This irregularity may have occurred in the analysis of the filter strip.

Average activity per unit volume of air was obtained from the stationary filters, as was done in the ventilation systems. Results are given

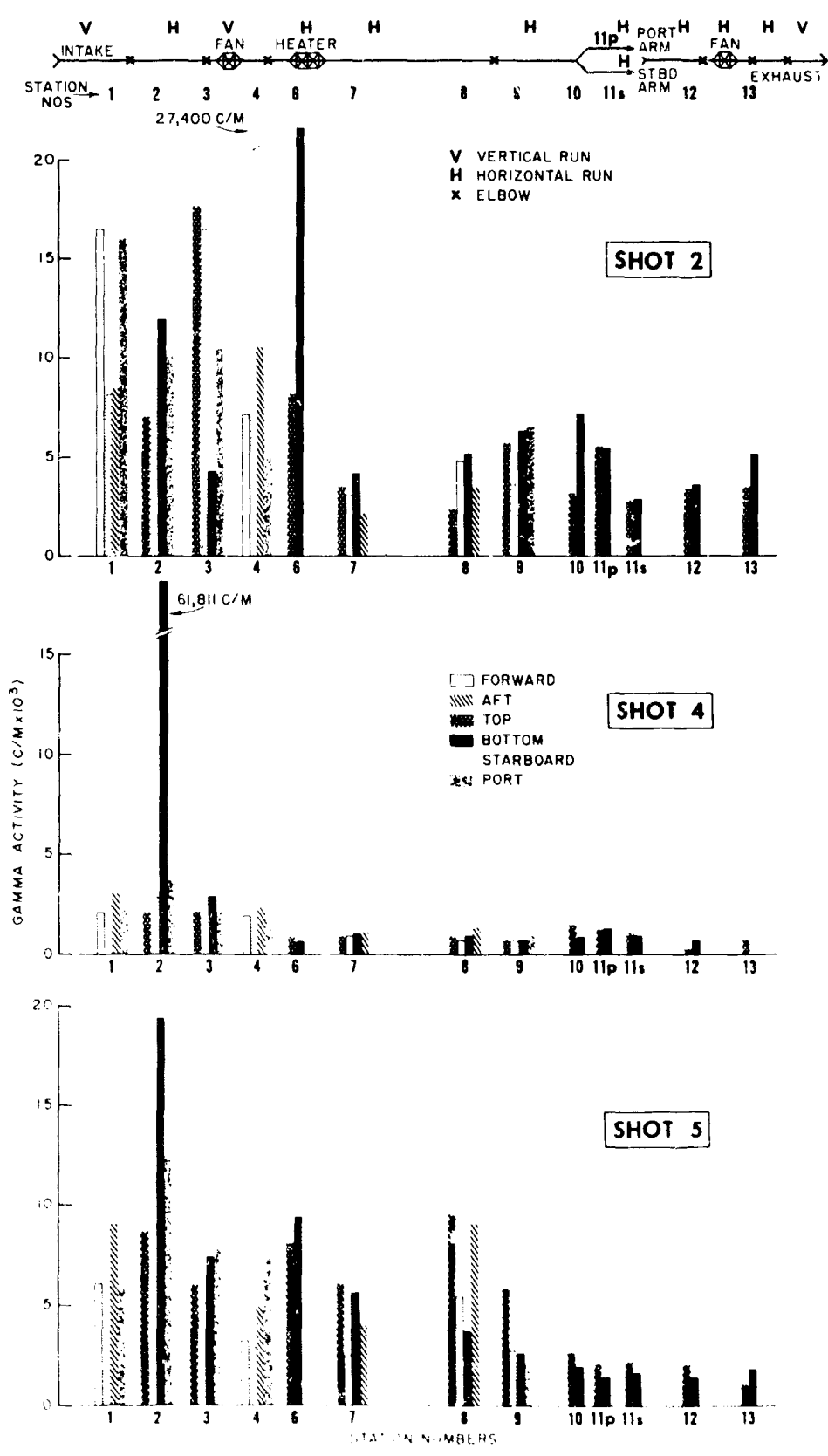

Figure 6.29 Duct section activities at S+10 days for three shots, Condition II, YAG 40.

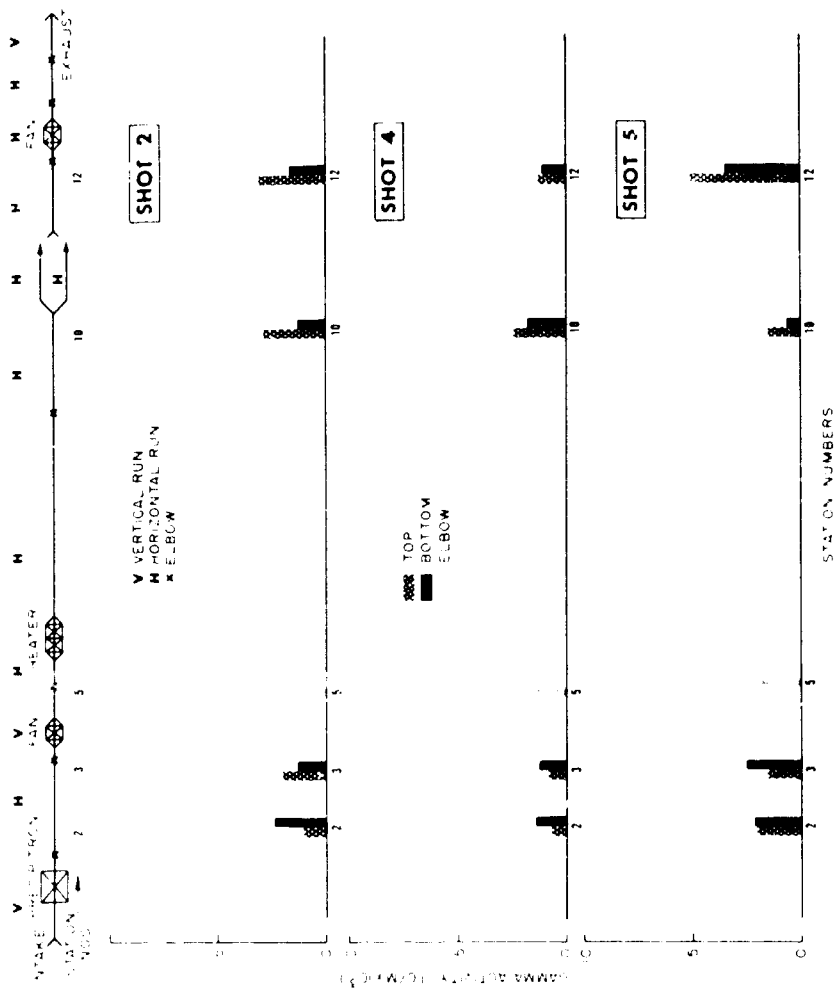

Figure 6.31 Duct section activities at S410 days for three shots, Condition IV, YAG 40.

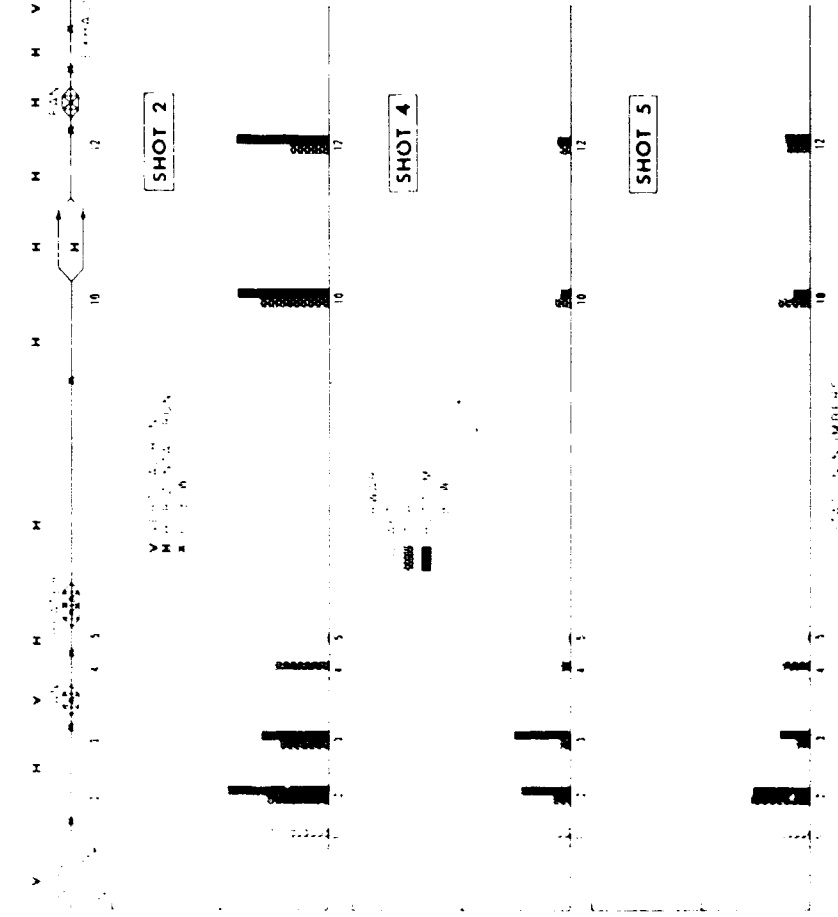

Figure 6.30 Duct section activities at S410 days for three shots, Condition III, YAG 40.

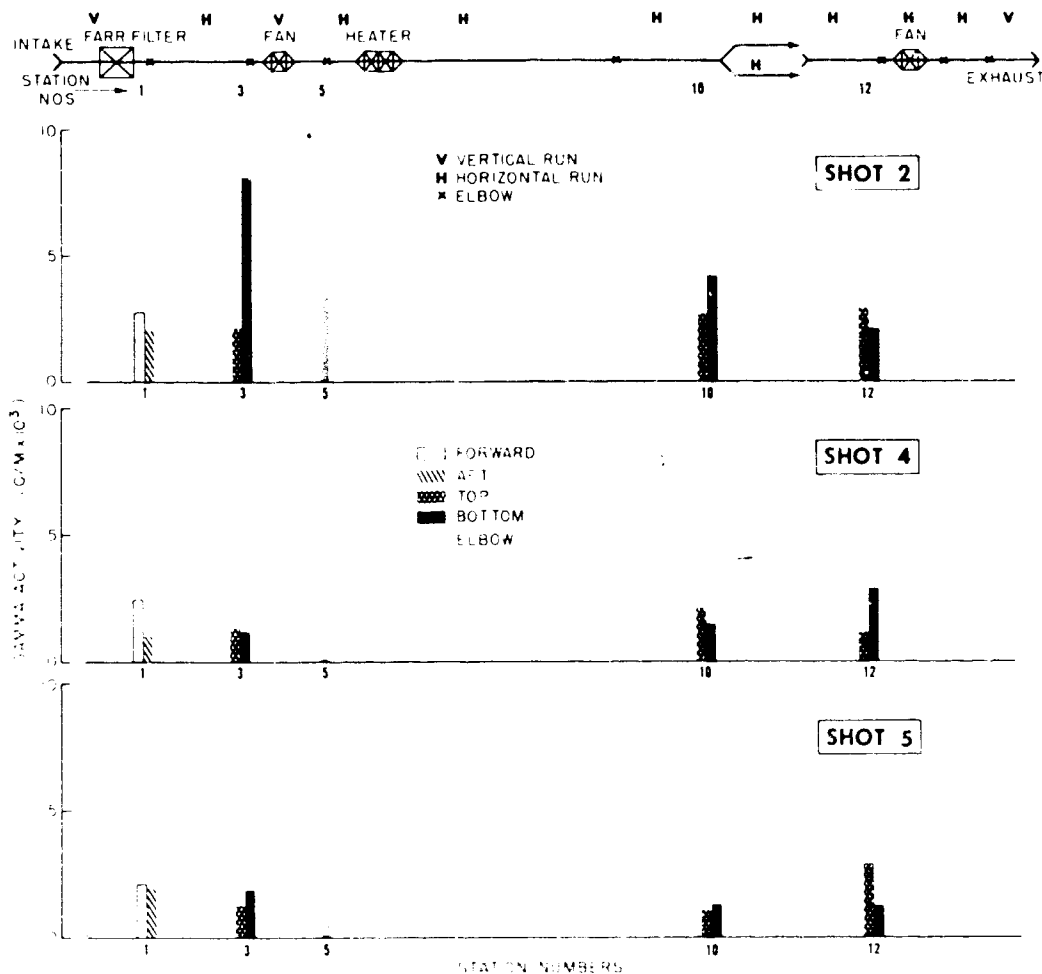

Figure 6.32 Duct section Activities at S+10 days for three shots, Condition V, YAG 40.

in Tables 6.8 through 6.10. The derivation of total volume of airflow through the filters is given in Appendix E.

Prior to Shot 4, the flow rate through the particle collectors in the firerooms had been reduced from 10 cfm to about 2 cfm to avoid excessive filter loading. This measure was not successful. The values given in Table 6.9 for the results of beta and gamma counts of the molecular filters for Shots 4 and 5 are of little significance to air sampling results, since the flow rates were too low to be measured. The data presented in Table 6.10 are derived from molecular filters for Shot 2 and from stationary continuous air sampler filters for Shot 5.

6.6.3.2 Deposition of Airborne Material. The gamma counting rates of duct sections and surface samples taken from the boiler-air systems of YAG 39 and YAG 40 appear in Table 6.11. A dashed line indicates the sample was lost in handling. See Figures 6.17 through 6.19 for identification of the duct-section locations.

Values of activity deposited on the inside surfaces of cone liners taken from the boiler systems are given in Table 6.12.

6.6.4 Results of Weatherside Measurements. Values for both the



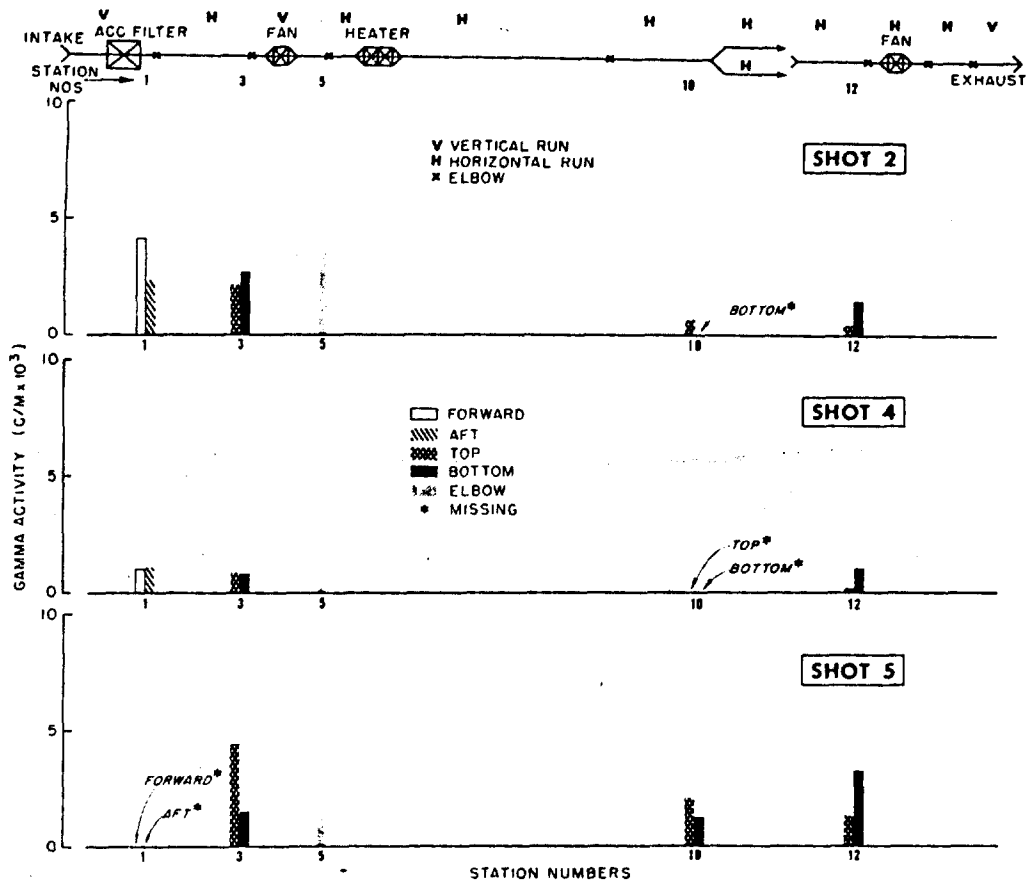

Figure 6.33 Duct section activities at S+10 days for three shots, Condition VI, YAG 40.

TABLE 6.8 BETA COUNT RATES OF THE MOLECULAR FILTERS IN THE FIREROOMS FOR SHOTS 4 AND 5

Location	Sample Number	Shot 4		Shot 5	
		B counts per minute corrected for decay to 10 days, corrected to a diameter of 9.00 cm	Sum of counts on high flow and low flow heads = total B c/m of the particle collector at S+10 days	B counts per minute corrected for decay to 10 days, corrected to a diameter of 9.00 cm	Sum of counts on high flow and low flow heads = total B c/m of the particle collector at S+10 days
Fireroom, YAG 40	91	$11.7 \times 10^3$	$19.2 \times 10^3$	$4.79 \times 10^3$	$9.24 \times 10^3$
	92	$7.46 \times 10^3$		$4.45 \times 10^3$	
Fireroom, YAG 39	111	$8.49 \times 10^3$	$12.7 \times 10^3$	$528 \times 10^3$	$564 \times 10^3$
	112	$4.25 \times 10^3$		$35.7 \times 10^3$	

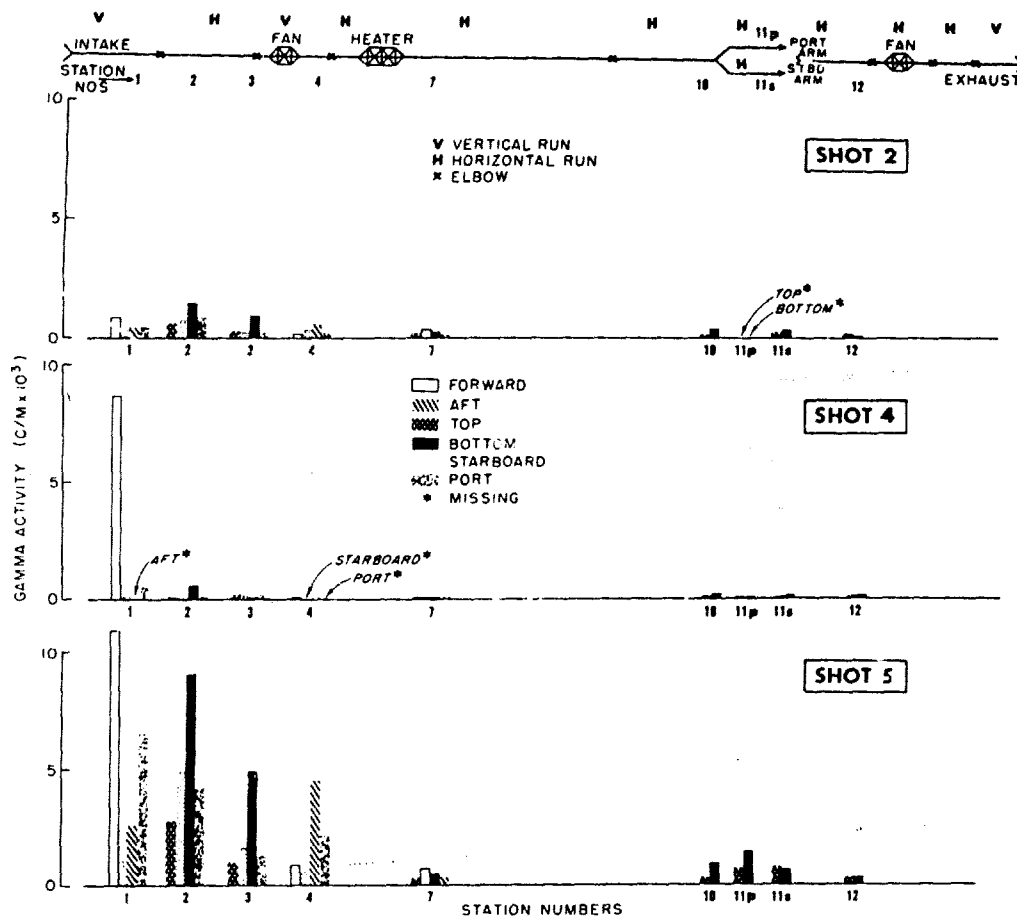

Figure 6.34 Duct section activities at S+10 days for three shots, Condition IIA, YAG 39.

TABLE 6.9 GAMMA COUNT RATES OF THE MOLECULAR FILTERS IN THE FIREROOMS FOR THREE SHOTS

Location	Sample Number	Shot 2		Shot 4		Shot 5	
		γ c/m corrected for decay to 10 days	Sum of counts on high flow heads = total γ c/m per particle collector	γ c/m corrected for decay to 10 days	Sum of counts on high flow and low flow heads = total γ c/m per particle collector	γ c/m corrected for decay to 10 days	Sum of counts on high flow and low flow heads = total γ c/m per particle collector
Fireroom, YAG 40	91	$1.79 \times 10^3$	$3.15 \times 10^3$	$0.222 \times 10^3$	$0.452 \times 10^3$	$0.0078 \times 10^3$	$0.013 \times 10^3$
	92	$1.35 \times 10^3$		$0.230 \times 10^3$		$0.0047 \times 10^3$	
Fireroom, YAG 39	111	$0.944 \times 10^3$	$0.635 \times 10^3$	$0.226 \times 10^3$	$0.420 \times 10^3$	$3.16 \times 10^3$	$3.35 \times 10^3$
	112	$0.302 \times 10^3$		$0.194 \times 10^3$		$0.188 \times 10^3$	
Fireroom, YAG 40	22c <sup>(a)</sup>						$1.65 \times 10^4$
Fireroom, YAG 39	25c <sup>(b)</sup>						$2.43 \times 10^4$

(a) 22C is a total sample taken from a continuous air sampler at the same location as Particle Collector 9. Since the strip of filter paper did not move, sample count is equivalent to a molecular filter count.  
 (b) For the same reason 25C is equivalent to a molecular filter at Particle Collector 11.

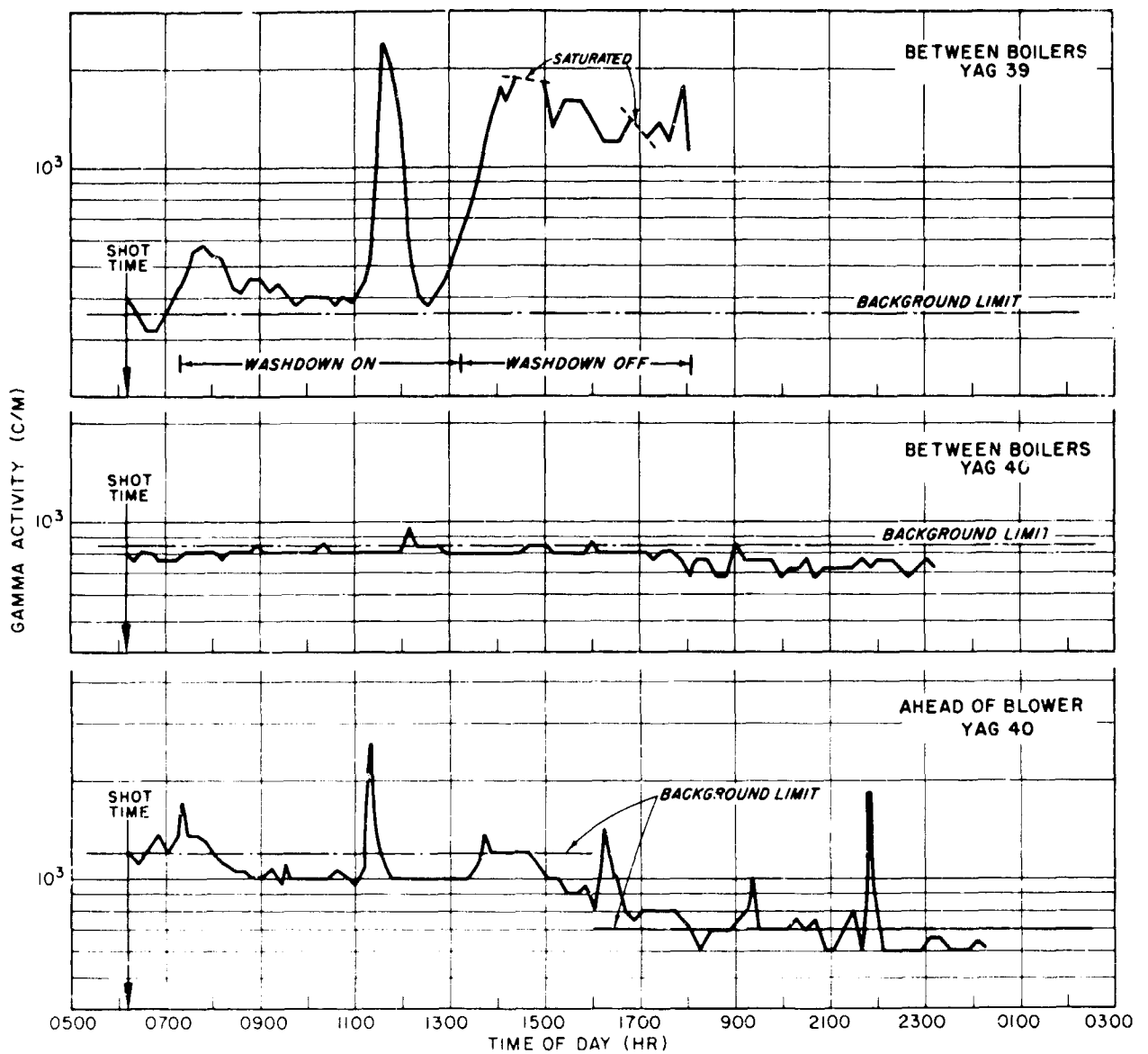

Figure 6.35 Activity concentrations in the boiler air systems of the YAG 39 and YAG 40 as a function of time at S+10 days, Shot 4.

TABLE 6.10 ACTIVE AEROSOL CONCENTRATIONS IN THE FIREROOMS FOR SHOTS 2 AND 5

Location	$\gamma$ c/m/ft <sup>3</sup> of air at S+10 days	$\gamma$ c/m/ft <sup>3</sup> of air at S+10 days
Fireroom, YAG 40	9.0	2.6
Fireroom, YAG 39	1.1	2.7

TABLE 6.11 GAMMA ACTIVITIES OF BOILER AIR DUCT SECTIONS AND SURFACE SAMPLES FOR THREE SHOTS AT 8+10 DAYS<sup>(a)</sup>

Duct Section No.	Shot 2		Shot 4		Shot 5	
	YAG 39 γ c/m at S+10 days	YAG 40 γ c/m at S+10 days	YAG 39 γ c/m at S+10 days	YAG 40 γ c/m at S+10 days	YAG 39 γ c/m at S+10 days	YAG 40 γ c/m at S+10 days
1	N	---	0.77 x 10 <sup>3</sup>	1.03 x 10 <sup>3</sup>	N	N
2	O	4.04 x 10 <sup>3</sup>	0.48 x 10 <sup>3</sup>	---	O	O
3	N	---	0.25 x 10 <sup>3</sup>	0.33 x 10 <sup>3</sup>	N	N
4	E	7.14 x 10 <sup>3</sup>	0.34 x 10 <sup>3</sup>	2.95 x 10 <sup>3</sup>	E	E
5	---	---	0.23 x 10 <sup>3</sup>	0.52 x 10 <sup>3</sup>	---	---
6	---	4.21 x 10 <sup>3</sup>	0.13 x 10 <sup>3</sup>	1.23 x 10 <sup>3</sup>	---	---
7	---	2.86 x 10 <sup>3</sup>	0.18 x 10 <sup>3</sup>	0.73 x 10 <sup>3</sup>	---	---
8	---	2.93 x 10 <sup>3</sup>	---	2.29 x 10 <sup>3</sup>	---	---
9	N	5.95 x 10 <sup>3</sup>	---	1.12 x 10 <sup>3</sup>	N	N
10	O	---	0.31 x 10 <sup>3</sup>	---	O	O
11	N	2.93 x 10 <sup>3</sup>	---	0.14 x 10 <sup>3</sup>	N	N
12	E	5.42 x 10 <sup>3</sup>	0.92 x 10 <sup>3</sup>	0.75 x 10 <sup>3</sup>	E	E
13	---	1.19 x 10 <sup>3</sup>	---	0.35 x 10 <sup>3</sup>	---	---
14	---	---	---	0.74 x 10 <sup>3</sup>	---	---
15	---	1.27 x 10 <sup>3</sup>	0.083 x 10 <sup>3</sup>	0.66 x 10 <sup>3</sup>	---	---
16	---	---	---	0.88 x 10 <sup>3</sup>	---	---
17	bkg	0.98 x 10 <sup>3</sup>	0.056 x 10 <sup>3</sup>	0.39 x 10 <sup>3</sup>	0.12 x 10 <sup>3</sup>	1.25 x 10 <sup>3</sup>
18	0.12 x 10 <sup>3</sup>	6.90 x 10 <sup>3</sup>	0.12 x 10 <sup>3</sup>	0.37 x 10 <sup>3</sup>	1.30 x 10 <sup>3</sup>	0.50 x 10 <sup>3</sup>
19	okg	1.01 x 10 <sup>3</sup>	0.092 x 10 <sup>3</sup>	0.50 x 10 <sup>3</sup>	1.62 x 10 <sup>3</sup>	1.41 x 10 <sup>3</sup>
20	0.006 x 10 <sup>3</sup>	0.11 x 10 <sup>3</sup>	0.060 x 10 <sup>3</sup>	1.09 x 10 <sup>3</sup>	0.14 x 10 <sup>3</sup>	0.98 x 10 <sup>3</sup>
21	bkg	0.63 x 10 <sup>3</sup>	0.069 x 10 <sup>3</sup>	0.18 x 10 <sup>3</sup>	0.13 x 10 <sup>3</sup>	0.67 x 10 <sup>3</sup>
22	---	4.02 x 10 <sup>3</sup>	0.089 x 10 <sup>3</sup>	0.33 x 10 <sup>3</sup>	---	1.58 x 10 <sup>3</sup>
23	0.007 x 10 <sup>3</sup>	0.75 x 10 <sup>3</sup>	0.075 x 10 <sup>3</sup>	0.49 x 10 <sup>3</sup>	0.42 x 10 <sup>3</sup>	0.92 x 10 <sup>3</sup>
24	bkg	0.93 x 10 <sup>3</sup>	0.27 x 10 <sup>3</sup>	0.31 x 10 <sup>3</sup>	0.44 x 10 <sup>3</sup>	0.75 x 10 <sup>3</sup>
25	bkg	bkg	0.055 x 10 <sup>3</sup>	---	0.14 x 10 <sup>3</sup>	1.17 x 10 <sup>3</sup>
26	bkg	0.20 x 10 <sup>3</sup>	0.052 x 10 <sup>3</sup>	0.37 x 10 <sup>3</sup>	0.17 x 10 <sup>3</sup>	0.72 x 10 <sup>3</sup>
27	0.18 x 10 <sup>3</sup>	0.46 x 10 <sup>3</sup>	0.11 x 10 <sup>3</sup>	0.27 x 10 <sup>3</sup>	0.29 x 10 <sup>3</sup>	0.76 x 10 <sup>3</sup>
28	0.032 x 10 <sup>3</sup>	0.11 x 10 <sup>3</sup>	0.099 x 10 <sup>3</sup>	0.16 x 10 <sup>3</sup>	0.11 x 10 <sup>3</sup>	---
29	bkg	0.88 x 10 <sup>3</sup>	0.049 x 10 <sup>3</sup>	0.79 x 10 <sup>3</sup>	0.077 x 10 <sup>3</sup>	2.40 x 10 <sup>3</sup>
30	0.011 x 10 <sup>3</sup>	0.71 x 10 <sup>3</sup>	0.020 x 10 <sup>3</sup>	1.62 x 10 <sup>3</sup>	0.032 x 10 <sup>3</sup>	6.92 x 10 <sup>3</sup>
31	bkg	---	0.10 x 10 <sup>3</sup>	2.22 x 10 <sup>3</sup>	---	2.49 x 10 <sup>3</sup>
32	0.11 x 10 <sup>3</sup>	0.86 x 10 <sup>3</sup>	0.081 x 10 <sup>3</sup>	0.93 x 10 <sup>3</sup>	0.13 x 10 <sup>3</sup>	1.60 x 10 <sup>3</sup>
33	0.005 x 10 <sup>3</sup>	0.70 x 10 <sup>3</sup>	0.094 x 10 <sup>3</sup>	0.72 x 10 <sup>3</sup>	0.16 x 10 <sup>3</sup>	1.41 x 10 <sup>3</sup>
34	0.011 x 10 <sup>3</sup>	0.86 x 10 <sup>3</sup>	0.004 x 10 <sup>3</sup>	0.77 x 10 <sup>3</sup>	0.15 x 10 <sup>3</sup>	1.93 x 10 <sup>3</sup>
35	bkg	0.71 x 10 <sup>3</sup>	0.026 x 10 <sup>3</sup>	0.75 x 10 <sup>3</sup>	0.096 x 10 <sup>3</sup>	0.70 x 10 <sup>3</sup>
36	---	0.63 x 10 <sup>3</sup>	0.026 x 10 <sup>3</sup>	0.64 x 10 <sup>3</sup>	0.12 x 10 <sup>3</sup>	1.29 x 10 <sup>3</sup>
37	bkg	1.37 x 10 <sup>3</sup>	0.069 x 10 <sup>3</sup>	1.21 x 10 <sup>3</sup>	0.13 x 10 <sup>3</sup>	0.40 x 10 <sup>3</sup>
38	0.031 x 10 <sup>3</sup>	0.98 x 10 <sup>3</sup>	0.21 x 10 <sup>3</sup>	0.71 x 10 <sup>3</sup>	2.20 x 10 <sup>3</sup>	8.63 x 10 <sup>3</sup>
39	0.017 x 10 <sup>3</sup>	1.73 x 10 <sup>3</sup>	0.10 x 10 <sup>3</sup>	0.74 x 10 <sup>3</sup>	0.40 x 10 <sup>3</sup>	0.16 x 10 <sup>3</sup>
40	bkg	0.19 x 10 <sup>3</sup>	0.025 x 10 <sup>3</sup>	0.88 x 10 <sup>3</sup>	1.59 x 10 <sup>3</sup>	3.70 x 10 <sup>3</sup>

(a) Count rates given are for 4-by-6-in. collecting surfaces.

concentration of airborne activity and the deposition of airborne material were obtained from weatherside measurements.

6.6.4.1 Concentration of Airborne Activity. Three records of activity versus time shown in Figure 6.36 were obtained from weatherside stations from Shots 4 and 5. The sampler on top of the bridge, YAG 40, never operated successfully. The records shown are from the other two stations. The peak values of gamma activity shown on the curves are in much smaller ratio to corresponding peaks in the ventilation systems than are the above- and below-decks molecular filter count ratios. It is expected that the smaller ratios found from the curves result from greater loss

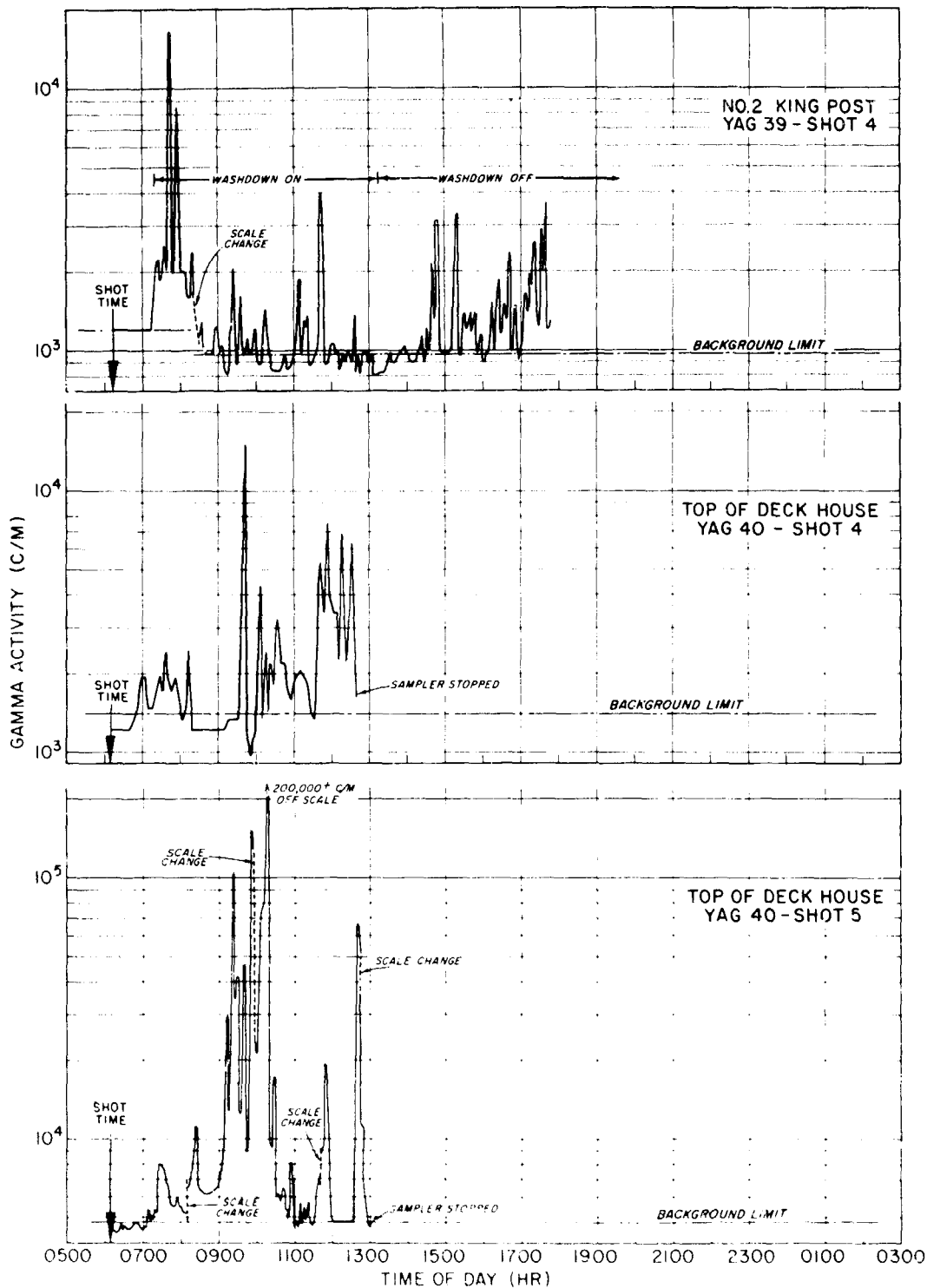

Figure 6.36 Weatherside activity concentration on the YAG 39 and YAG 40 as a function of time at S+10 days, Shots 4 and 5.

of activity to the cone liners above decks than occurred below decks.

Although the time of washdown spray operation is indicated for the YAG 39 sampler, it is suspected that the increase of activity after the washdown stopped is coincidental, because the sampler was mounted above the washdown spray. Differences in fallout arrival between the YAG 39 and

TABLE 6.12 GAMMA COUNT RATES FOR CONE LINERS IN BOILER SYSTEMS FOR THREE SHOTS AT S+10 DAYS

Cone liner from air sampler located at:	Overall length of cone liner (in.)	Shot 2	Shot 4	Shot 5
		$\gamma$ c/m	$\gamma$ c/m	$\gamma$ c/m
Beneath fidley space Fireroom, YAG 40	25	$0.960 \times 10^3$	$0.458 \times 10^3$	-
Ahead of forced draft Blower-boiler air duct, YAG 40	24	$1.89 \times 10^3$	$0.410 \times 10^3$	-
In duct ahead of port windbox, YAG 40	26	$5.49 \times 10^3$	$0.166 \times 10^3$	-
Between boilers above firing aisle Fireroom, YAG 40	4 (cone stub)	$0.885 \times 10^3$	$0.810 \times 10^3$	$1.74 \times 10^3$
Ahead of forced draft draft blower-boiler air duct, YAG 39	23	-	$0.670 \times 10^3$	-
Between boilers above firing aisle Fireroom, YAG 39	4 (cone stub)	$0.031 \times 10^3$	$0.454 \times 10^3$	$0.277 \times 10^3$

YAG 40 for Shot 4 are represented in a comparison of the two plots of weatherside activity versus time for Shot 4.

In previous sections, the molecular filters have been treated as indices of the active aerosol concentrations at the locations where they were installed. However, above decks---where the open, unprotected filter faces were subject to damage by the wind and rain and where fallout material could deposit on them regardless of the flow rates through the filters---it was believed that the DMT filter material, partially protected by a 4-inch-diameter cylindrical intake, would afford a better relation between activity collected and the total volume of air sampled.

DMT filter sample count rate at S/10 days was  $5.82 \times 10^6$  c/m for Shot 4 and  $13.2 \times 10^6$  c/m for Shot 5. It was found that the exposed screen holding the DMT needles in place had roughly the same activity as the filter material itself; therefore, the best estimate of the total activity drawn in by the sampler for the two shots at S / 10 days is: Shot 4,  $11.6 \times 10^6$  c/m; Shot 5,  $2.6 \times 10^7$  c/m.

The average gamma activity per cubic foot of air above decks on YAG 40 for Shots 4 and 5 becomes  $1.15 \times 10^3$  c/m/cu ft and  $2.6 \times 10^3$  c/m/cu ft, respectively. These values are averaged between time of start of fallout and time of sampler shutdown.

No direct estimate is available for YAG 39, since no DMT filters were mounted on that ship.

6.6.4.2 Deposition of Airborne Material. Results of beta and gamma counts of the weatherside molecular filters are given in Table 6.13.

The adhesive-coated papers were rolled into the shape of a cylinder 3 inches long and counted in the 4  $\pi$  ionization chamber. The results are expressed in Table 6.14.

TABLE 6.13 BETA AND GAMMA COUNT RATES OF THE WEATHERSIDE MOLECULAR FILTERS FOR SHOTS 2, 4, AND 5 AT S+10 DAYS

Location	Sample Number	Shot 2	Shot 4		Shot 5	
		$\gamma$ c/m dia. sample (9.0 cm dia. sample)	$\gamma$ c/m dia. sample (9.0 cm dia. sample)	$\beta$ c/m (corrected to 9.0 cm dia. sample)	$\gamma$ c/m dia. sample (9.0 cm dia. sample)	$\beta$ c/m (corrected to 9.0 cm dia. sample)
Top of deckhouse YAG 40	71	$9.74 \times 10^4$	$2.42 \times 10^6$	$8.4 \times 10^7$	$2.67 \times 10^6$	$3.0 \times 10^8$
	72	$5.1 \times 10^7$	-	-	$1.59 \times 10^7$	$1.66 \times 10^9$
Top of bridge YAG 40	81	$6.2 \times 10^7$	-	-	-	-
	82	$1.47 \times 10^5$	$6.16 \times 10^5$	$2.54 \times 10^7$	-	-
Top of mast YAG 39	101	$1.38 \times 10^4$	$4.61 \times 10^6$	$2.51 \times 10^8$	$1.06 \times 10^6$	$1.72 \times 10^8$
	102	$1.4 \times 10^6$	$1.55 \times 10^6$	$2.4 \times 10^7$	$6.43 \times 10^6$	$3.85 \times 10^9$

TABLE 6.14 SURFACE ACTIVITIES OF ADHESIVE-COATED PAPERS FOR SHOTS 4 AND 5 AT S+10 DAYS

Location of Sample	Orientation of Sample	Shot 4		Shot 5	
		YAG 39 ( $\gamma$ c/m/ft <sup>2</sup> )	YAG 40 ( $\gamma$ c/m/ft <sup>2</sup> )	YAG 39 ( $\gamma$ c/m/ft <sup>2</sup> )	YAG 40 ( $\gamma$ c/m/ft <sup>2</sup> )
No. 1 kingpost	horizontal surface facing upwards	-	-	$1.42 \times 10^7$	-
No. 2 kingpost	horizontal surface facing upwards	$0.88 \times 10^7$	$10.5 \times 10^7$	$6.5 \times 10^7$	$2.8 \times 10^7$
Top of deckhouse	vertical surface facing forward	-	$0.83 \times 10^7$	-	$50.6 \times 10^7$

It is interesting to compare the results of the adhesive-coated fallout collectors with the activities found on the weatherside molecular filters (Table 6.15), where the latter are treated as surface collectors and the existence of airflow through the filters is disregarded.

The molecular filters are of an order of magnitude of 10 less than the adhesive-coated papers. Rain and wind following Shots 4 and 5 evidently washed much of the active material off the filters, in addition to tearing them badly.

There is little doubt that the better retention characteristics of the adhesive-coated surfaces contributed a great deal to the increased total count of these surfaces over the molecular filters.

Results of analyses of cone liners taken from weatherside air samplers are given in Table 6.16.

TABLE 6.15 SURFACE ACTIVITIES OF WEATHERSIDE  
MOLECULAR FILTERS FOR SHOTS 4 AND 5

Sample No.	Location	Shot 4 ( $\gamma$ c/m/ft <sup>2</sup> )	Shot 5 ( $\gamma$ c/m/ft <sup>2</sup> )
71	Top of deckhouse, YAG 40	$3.5 \times 10^6$	$3.9 \times 10^6$
72	Top of deckhouse, YAG 40, facing 180° from Sample 71	-	$2.3 \times 10^7$
81	Top of bridge, YAG 40	-	-
82	Top of bridge, YAG 40, facing 180° from Sample 81	$8.9 \times 10^5$	-
101	No. 2 kingpost, YAG 39	$6.7 \times 10^6$	$1.5 \times 10^6$
102	No. 2 kingpost, YAG 39, facing 180° from Sample 101	$2.2 \times 10^6$	$9.3 \times 10^6$

TABLE 6.16 GAMMA COUNT RATES FOR WEATHERSIDE  
CONE LINERS FOR THREE SHOTS AT 5.10 DAYS

Location of Cone Liner from Air Sampler	Overall Length of Cone Liner	Shot 2	Shot 4	Shot 5
		$\gamma$ counts per min.	$\gamma$ counts per min.	$\gamma$ counts per min.
Top of Deckhouse, YAG 40	29.5	$1.86 \times 10^6$	$2.42 \times 10^5$	$1.33 \times 10^7$
Top of Bridge, YAG 40	29.5	$6.66 \times 10^6$	-	$2.13 \times 10^7$
No. 2 Kingpost, YAG 39	29.5	-	$4.03 \times 10^5$	$2.58 \times 10^7$

## 6.7 DISCUSSION

**6.7.1 Comparison of Activity Concentrations.** Considering the DMT filter results to represent the activity above decks and the molecular filter results to represent the activity in each of the below-decks cubicles, a correlation can be made of the comparative reduction in activity for the three test areas on YAG 40.

Table 6.17 gives the average activity concentration in each cubicle as a fraction of the weatherside concentration.

Most of the larger particles or droplets were screened out when the air entered the mushroom ventilation intake. Either they fell past the intake or they were deposited inside the head by the cyclone action of the airstream. The reduction factor given for the fireroom, YAG 40, is considerably larger than is reasonable, judging from a comparison of duct section activities in boiler-air and ventilation ducts and from a comparison of the count rates for the cone lines taken from air samplers in the two firerooms and in Condition III, YAG 40. In general, there is



TABLE 6.17 RATIOS OF GAMMA ACTIVITY CONCENTRATIONS  
BELOW AND ABOVE DECKS FOR SHOTS 4 AND 5

Tests	Shot 4	Shot 5
	Fraction of Average $\gamma$ c/m/ft <sup>3</sup> of Air Gaining Access to the Space	Fraction of Average $\gamma$ c/m/ft <sup>3</sup> of Air Gaining Access to the Space
Condition I, YAG 40	$2.87 \times 10^{-4}$	$2.77 \times 10^{-4}$
Condition II, YAG 40	$1.91 \times 10^{-4}$	$1.08 \times 10^{-4}$
Condition III, YAG 40	$1.74 \times 10^{-4}$	$1.88 \times 10^{-4}$
Condition IV, YAG 40	-	$0.69 \times 10^{-5}$
Condition V, YAG 40	$2.26 \times 10^{-4}$	$1.62 \times 10^{-4}$
Condition VI, YAG 40	$0.96 \times 10^{-5}$	$0.65 \times 10^{-5}$
Fireroom, YAG 40	-	$1.0 \times 10^{-3}$

too little information pertaining to activity concentrations in the boiler-air system to permit an adequate comparison with the ventilation and weatherside test areas.

An order-of-magnitude estimate can be made of the activity reduction from the weatherside activity levels based upon cone-liner comparisons.

Average cone-liner activity below decks on YAG 40 is taken as the arithmetic average for the Station 5 cone liners in Conditions I, II, IV, V, and VI. Above decks, the arithmetic average of the cone liners is taken off those on top of the deckhouse and on the bridge deck. The YAG 39 instrument situation allows only a ratio between the liners from Station 5, Condition IIA, and the liner from the No. 2 kingpost to be derived. Agreement is good between Table 6.17 and Table 6.18 except for Shot 4 in the latter.

**6.7.2 Sampling Conditions.** It has been observed that flyash in the fireroom and in the boiler-air systems interfered considerably with the collection of airborne particulate matter. Flyash, not temperature, was the major threat to the acquisition of a good sample of airborne radioactive matter in this area of investigation.

TABLE 6.18 RATIO OF ACTIVITY CONCENTRATIONS BELOW AND  
ABOVE DECKS BASED ON CONE-LINER DATA FOR THREE SHOTS

	Shot 2	Shot 4	Shot 5
	Ratio of average cone liner $\gamma$ activity at Station 5 to average cone liner $\gamma$ activity on deck	Ratio of average cone liner $\gamma$ activity at Station 5 to average cone liner $\gamma$ activity on deck	Ratio of average cone liner $\gamma$ activity at Station 5 to average cone liner $\gamma$ activity on deck
YAG 40	$2.89 \times 10^{-4}$	$1.38 \times 10^{-3}$	$2.38 \times 10^{-4}$
YAG 39	-	$0.5 \times 10^{-3}$	$1.05 \times 10^{-5}$

Although quantities of oil and flyash were not absent in weatherside collections, wind and rain were predominantly responsible for distorting the samples obtained above decks. Therefore, the division of this study into three separate areas of investigation delineates the circumstances for which correction should be made before an adequate comparison may be drawn. For example, before a comparison between a beta count from a molecular filter sampling in the fireroom and a beta count from a molecular filter in the relatively clean air of a ventilation cubicle can be obtained, correction would have to be made for self-absorption of the fireroom sample. The comparison between a weatherside sample and a sample from the relatively directional air of a ventilated cubicle is still more difficult in that a sample collected isokinetically (Reference 19) from a moving airstream is different from that of a sample taken from nondirectional or still air, in that the latter contains a bias which is a function of particle size (Reference 20).

The situation is further complicated by a lack of certainty as to what was measured in the samples collected from the weatherside stations. It has been mentioned that the weatherside molecular filters were not shielded against direct impingement on the prevailing windstream, and it was observed that they were less active than the gummed surface collectors. It has been pointed out that the face velocity of the air entering the molecular filters was so much lower than the prevailing wind velocity that the molecular filters would be, at best, fixed-surface fallout collectors. Although the DMT filters were subject to this same circumstance, their samples were better protected against the ensuing rainstorms.

As a result of the absence of quantitative data from the continuous air samplers, the DMT filters were selected to provide the order of magnitude relationship between the above-decks and below-decks activity concentration. In general, all comparisons made between any two of the three test areas (Tables 6.17 and 6.18) should be looked upon primarily as order-of-magnitude estimates.

6.7.3 Airborne Material. Figure E.15, Appendix E, indicates that considerable quantities of radioactive matter were thrown out inside the air sampler cones long before reaching the filter paper surfaces. It is expected that the ratio of particulate matter deposited on cone liner to particulate matter entering cone would be much larger for the weatherside samplers than for the below-decks samplers. This situation is borne out qualitatively by a comparison of the activity ratios between weatherside samplers and below-decks samplers and the activity ratios between corresponding cone liners. At a particular time, the ratio between above- and below-decks air-sampler activity concentrations was less than the ratio of their cone activities.

It is notable that once fallout began, airborne activity concentrations on YAG 40 did not appreciably change after the cessation of fallout, at least until the samplers shut down. Deposited activity may have been redispersed in the air upon drying. This observation formed the basis of the estimate of average activity per unit volume of air for the 24 hour period.

Table 6.5 shows the marked uniformity of the airborne activity concentrations in these test systems, where no high efficiency particle

removing device was present. The particle concentration in the duct air was not greatly influenced by the flow rate through the duct. In comparing Conditions II and III for Shot 5 (Table 6.5), it can be seen that the average activity in the Condition III cubicle was only 23 percent less than that of the Condition II cubicle. However, a comparison of Figures 6.29 and 6.30 demonstrates that considerably more activity entered Condition II intake duct. For the apparently small particle sizes which gained access to the ventilation ducts, the airborne particulate concentration was little influenced by changes in flow rate over a range of 1000 cfm to the minimal flow rate of the no-fan situation (Condition III).

The amount of activity deposited inside the ducts was a function of the total activity carried through them, which in turn was a function of the flow rate. It is possible that systems operating at different rates permitted entrance of different particle-size populations, which circumstance would influence deposition and concentration values.

## 6.8 CONCLUSIONS

1. Arrival of fallout was irregular and the time of cessation of fallout could not be determined from continuous air samples.
2. Airborne activity concentrations within the unprotected ship were less by about a factor of  $5 \times 10^3$  than that exterior to this ship.
3. Cubicles in Conditions I, II, III and V, YAG 40, contained approximately the same activity per unit volume of air, regardless of the flow rate over the range tested.
4. The ACC filter and the precipitron effected a reduction of 94 percent to 98 percent in the airborne concentration.
5. Gamma radiation from the ducts studied in this test was not of greater order of magnitude than gamma radiation penetrating the decks from exterior surface deposits.
6. Significant comparisons could not be made between activity concentrations in boiler air systems and weatherside or ventilation areas.

## 6.9 RECOMMENDATIONS

From the standpoint of future investigation, the following suggestions are recommended:

1. Several features of ventilation ducts could be studied successfully on full-scale models in the laboratory: (1) relative retention abilities of ventilation intakes as a function of particle size; (2) change in concentration of airborne particulate matter passing through a duct as a function of duct shape, distance, and particle size; and (3) efficiency of protective devices as a function of the particle size and physical characteristics.
2. The observations made in this chapter comprise an isolated instance of a ship's exposure to fallout from thermonuclear explosions. Presumably, characteristics of the interior contamination of a ship would have been significantly different had the nature and concentration of the fallout been different, especially in the region of throwout or base surge. It is recommended that interior contamination resulting from

a standardized unprotected ventilation duct be studied under different fallout conditions.

3. A determination of washdown effectiveness in inhibiting the contamination of a ship's interior could be better accomplished by performing comparison measurements simultaneously on the same ship to remove the uncertainties attached to defining relative fallout exposures at two or more locations.

4. It is considered that a study of a ship's interior contamination could be best served through access to the following kinds of data: (1) total activity per unit volume of air above and below decks; (2) average number of radioactive airborne particles above and below decks; and (3) total activity deposited on unit area above and below decks.

5. It is further recommended that the measurements be made on samples removed from the ship to avoid the interference of radiation fields and that samples collected below decks be derived from large samples of air and large collecting surfaces.

## Chapter 7

# AIR-MONITORING EVALUATION

B. M. Carder    A. H. Redmond

A semiportable air monitor developed at NRDL was partially tested under field conditions. Data on the air-contamination levels around a ship after nuclear detonations were taken and related to the corresponding roentgen intensity at the sampling point.

The air monitor was designed to indicate a level of 0.3 microcuries of beta emitter per cubic meter of air within 1 min after such a concentration occurred. Because of partial instrument failure, in particular, failure of the detecting system to function in a radiation field of low energy photons, continuous readings of activity during collection of the samples were not feasible. The sampling equipment and paper-changing program devices worked satisfactorily; but since the inadequacy occurred in the detecting system, the activity of the samples was counted at a later time. Counting these samples at the later time indicated that a number of samples collected as late as 17 hr after the detonation gave an average activity in excess of the level at which an alarm should have been given by the detecting system.

### 7.1 OBJECTIVE

The principal objective of the early warning air-monitor work was to make a field test of equipment developed during the preceding year. A secondary objective was to accumulate data on the beta emitter in air around a ship and to correlate the level of the collected beta-emitter contamination with the associated gamma-intensity level, which was expected to be small.

### 7.2 BACKGROUND AND THEORY

Calculations at NRDL have shown that large concentrations of total fission products may be inhaled in air at early times after a detonation without ultimately overexposing bone to internal beta-emitting deposits. Since permissible concentrations for an hour's inhalation decrease rapidly with time, it is desirable to limit exposures. Limiting exposures entails knowing the concentration of activity in air inhaled during a given period of time. Such material as is in dynamic equilibrium suspension in air is considered potentially capable of entering the lungs and being completely retained. Thus, the need for apparatus capable of determining the concentration in suspension equilibrium in air at any given time is evident.

For measuring the concentration of activity in the air, the volume

of air flowing through the apparatus, as well as the corresponding increment to activity collected during the sampling period, must be determined. If the changing level of activity on the collector is recorded continuously, the instantaneous level of activity in air can be determined from the slope of the curve of activity vs time. Since a detector for beta radiation is also sensitive to gamma radiation, the gamma background must be eliminated from this curve. In a contaminating shot on land, where the radiation field from far beyond the immediate surroundings may be large, the instrument must be designed to eliminate this background. Above some critical level of gamma background, the instrument will become inoperative, but in such case the gamma intensity would undoubtedly have led to countermeasures that likely involved some restriction of ventilation.

The gamma level corresponding to a concentration of fission products of  $1 \mu\text{c}/\text{cu m}$  may be reasonably assumed less than  $2 \text{ mr}/\text{hr}$ . Thus, the gamma level can be low while the concentration of beta-emitter approaches a magnitude of some concern. Failure to monitor the air for beta-emitter concentrations may lead to needless restriction of ventilation on the basis of gamma radiation and in the absence of local air contamination.

### 7.3 DESCRIPTION OF SEMI-PORTABLE AIR MONITOR

The entire air monitoring equipment weighed about 50 lb and was operated from the ship's 115-v power supply. Its two major components were the collection system, including the mechanism for changing the filter paper, and the device for detecting beta emitter on the filter paper. In the collection system a small turboblower from a vacuum cleaner drew air through a filter paper (Army Chemical Corps, type No. 5) at a face velocity of 2 m/sec (14 to 15 cfm), thereby ensuring collection of  $0.3 \mu$  particles at an efficiency of 95 to 98 percent. The filter paper was on a roll that permitted 200 changes, either at pre-set intervals or whenever the beta-emitter on the paper was sufficient to cause the sensing and recording devices to read full scale.

A principal feature of the air monitor was the provision for showing an alarm level of activity in the air. If a full-scale reading occurred within 1 min of a previous change, an alarm signal was activated by relays set to function at  $1 \mu\text{c}/\text{cu m}$  of filtered air. When full-scale readings resulted later than 1 min after a preceding change, a warning light indicated the presence of activity.

The device for detecting beta emitter on the filter paper included two thin-window GM tubes placed  $\frac{1}{2}$  in. above the paper, the entire counting head and collection assembly being surrounded by a lead shield  $\frac{1}{2}$  in. thick. It had been shown in the laboratory that such a shield reduced gamma radiation from an external field of several r/hr to an acceptable level. In this arrangement beta particles from the collector paper could pass through both tubes in series and initiate a coincidence count; since external gamma radiation was not expected to count in coincidence, this minimized gamma background. The output signal from the coincidence circuit passed through a discriminator and into a rate-meter-recorder arrangement. Activity on the paper was compared with the readings from standard samples of Sr-90 by calibration.

## 7.4 OPERATIONS

Two similar air monitors, neither of which was completely tested before shipment, were used at the site. One was mounted on the flying bridge deck of the YAG 40 and set to collect samples at 30-min intervals. The other was located in barracks on Site Elmer. It was calibrated at intervals and was operated manually.

## 7.5 RESULTS AND DISCUSSION

Data taken on Shots 1, 2, and 4 are given in Tables 7.1 through 7.4. The air monitor on the flying bridge of the YAG 40 was set to collect

TABLE 7.1 SHOT 1 BETA ACTIVITY ON THE FLYING BRIDGE OF THE YAG 40

Sample Number	Mean Time of Collection After $t_0$ (hr)	Microcuries on Sample at $t_0 + 557$ hr	$\mu\text{c}/\text{cu m}$ at $t_0 + 557$ hr (approx.)	Theoretical Multiplier	$\mu\text{c}/\text{cu m}$ at Collection Time
8	1	0.000	0.0000	1000	0.00
9	1.5	0.001	0.0001	620	0.09
10	2	0.008	0.0007	455	0.32
11	2.5	0.024	0.0020	355	0.70
12	3	0.018	0.0015	300	0.45
14	3.5	0.018	0.0015	260	0.39
15	4	0.014	0.0012	235	0.28
16	4.5	0.013	0.0011	215	0.24
19	5	0.014	0.0012	200	0.24
20	5.5	0.013	0.0011	185	0.20
21	6	0.013	0.0011	175	0.19
22	6.5	0.008	0.0005	165	0.08
23	7	0.007	0.0006	155	0.09
24	7.5	0.003	0.0002	146	0.03
25	8	0.003	0.0002	139	0.03
26	8.5	0.003	0.0003	132	0.04
27	9	0.018	0.0015	126	0.19
28	9.5	0.029	0.0024	120	0.29
29	10	0.039	0.0033	115	0.38
30	10.5	0.045	0.0038	110	0.42
31	11	0.042	0.0035	106	0.37
32	11.5	0.053	0.0044	103	0.45
33	12	0.064	0.0054	100	0.54
35	12.5	0.059	0.0049	97	0.48
36	13	0.072	0.0060	94	0.56
38	13.5	0.064	0.0054	91	0.49
39	14	0.057	0.0048	88	0.42
40	14.5	0.054	0.0045	85	0.38
41	15	0.059	0.0049	83	0.41
43	15.5	0.064	0.0054	81	0.44
45	16	0.072	0.0060	79	0.47
46	16.5	0.064	0.0054	77	0.42
47	17	0.046	0.0039	75	0.29
Sampler stopped.					
48	33	0.017	0.0015	40	0.06
49	33.5	0.015	0.0013	39	0.05
50	34	0.024	0.0020	39	0.08
51	34.5	0.003	0.0002	38	0.01
52	35	0.003	0.0002	38	0.01
53-03 low					
54	40.5	0.015	0.0013	32	0.04
All other samples low.					

30-min samples from Shots 1 and 4 and 40-min samples from Shot 2. At Shot 4, the monitor was set to record beta buildup on filter paper; but failure of the equipment prevented making these records, and only the 30-min samples were obtained. The air monitor in the barracks was operated manually to obtain the beta buildup on filter paper.

Beta activity on samples taken at Shot 1 was determined with a proportional counter at ( $t_0 + 557$  hr); at Shot 2, at ( $t_0 + 201\frac{1}{2}$  hr); and at Shot 4, at ( $t_0 + 1750$  hr).

The theoretical decay curves, shown in Figure 7.1 were used to yield multipliers that would give the approximate sample strength at the time of collection. Information for these curves was obtained from Project 2.5 and 2.6 personnel at the site.

The data are given principally for the record, and little attempt has been made to interpret them phenomenologically. They are plotted in Figures 7.2 and 7.3, together with information on the corresponding gamma intensity obtained by another group in the project. One interesting point in the histograms is the appearance of secondary peaks of beta-

TABLE 7.2 SHOT 2 BETA ACTIVITY ON FLYING BRIDGE OF THE YAG 40

Sample Number	Mean Time of Collection After $t_0$ (hr)	Microcuries on Sample at $t_0 + 201\frac{1}{2}$ hr	$\mu\text{c}/\text{cu m}$ at $t_0 + 201$ hr (approx.)	Multiplier	$\mu\text{c}/\text{cu m}$ at Collection Time
1-8	1.6	0.000	0.0000	120	0.00
1-9	2.3	0.002	0.0001	80	0.01
1-10	3.0	0.034	0.0021	62	0.13
1-11	3.6	0.040	0.0025	52.5	0.13
1-12	4.3	0.044	0.0028	45.5	0.12
1-13	5.0	0.043	0.0027	41.0	0.11
1-14	5.6	0.047	0.0029	37.8	0.11
1-15	6.3	0.044	0.0028	34.6	0.10
1-16	7.0	0.318	0.0199	32.0	0.64
1-17	7.6	0.052	0.0033	30.0	0.10
1-18	8.3	0.044	0.0028	28.0	0.08
1-19	9.0	0.063	0.0039	26.2	0.10
1-20	9.6	0.170	0.0106	24.7	0.26
1-21	10.3	0.044	0.0028	23.2	0.06
1-22	11.0	0.032	0.0020	21.9	0.04
1-23	11.6	0.069	0.0043	20.7	0.09
1-24	12.3	0.044	0.0028	19.8	0.05
1-25	13.0	0.016	0.0010	19.0	0.02
1-26	13.6	0.015	0.0009	18.3	0.02
1-27	14.3	0.014	0.0009	17.5	0.02
1-28	15.0	0.016	0.0010	17.0	0.02
1-29	15.6	0.021	0.0013	15.4	0.02
1-30	16.3	0.027	0.0016	15.9	0.03
1-31	17.0	0.136	0.0085	15.5	0.13
1-32	17.6	0.058	0.0036	15.1	0.05
1-33	18.3	25.0	1.56	14.7	22.9
1-34	19.0	0.300	0.0188	17	0.32

Samples 1-33 and 1-34 showed that the filter papers had been soaked, indicating that a rainstorm had probably washed contaminated material from nearby structures into air intake.

emitter concentrations occurring after the first peak. It seems that fractionation by sizes, with slower settling of smaller particles, may explain the occurrence of such high levels without a corresponding rise in the gamma intensity. As was stated earlier, the gamma background due to beta-emitter concentrations considerably higher than those observed would lead to negligible increases in the gamma intensity while still being of interest as internal hazards.

In general, the data taken on the YAG 40 indicate that the airborne beta-emitter concentration is often independent of the background gamma level. An initial background buildup seems to occur after the first airborne contamination is detected, as was noted particularly on Elmer. The



TABLE 7.3 BUILD-UP OF BETA ACTIVITY ON FILTER PAPER  
IN BARRACKS ON SITE ELMER, SHOT 2

Sample Number	Mean Time of Collection After to (hr)	Length of Collection (min)	Estimated $\mu\text{c}$ when Collected	Estimated $\mu\text{c}/\text{cu m}$ when Collected	Gamma Background $\text{mr}/\text{hr}$
2-14	9.8	29	0.00	0.00	0.6
2-15	10.3	29	0.03	0.003	
2-16	10.7	16	0.10	0.015	
2-17	10.9	14	0.10	0.017	
2-18	11.1	6	0.10	0.040	
2-19	11.2	5	0.10	0.048	
2-20	11.3	4	0.10	0.060	
2-21	11.3	3.5	0.10	0.069	
2-22	11.4	3.5	0.10	0.069	
2-23	11.4	2.5	0.10	0.096	
2-24	11.5	2.5	0.10	0.096	
2-25	11.6	2.5	0.10	0.096	
2-26	11.6	2.5	0.10	0.096	
2-27	11.7	2	0.10	0.120	
2-28	11.7	2	0.10	0.120	
2-29	11.8	5	0.30	0.146	
2-30	12.0	8	0.50	0.150	
2-31	12.1	9	0.40	0.107	
2-32	12.2	1	0.1(†)	0.2(†)	
2-33	12.4	12	0.2(†)	0.04(†)	
2-34	12.5	7	0.30	0.103	
2-35	12.6	2	0.1(†)	0.1(†)	
2-36	12.7	12	0.40	0.080	
2-37	12.9	4	0.20	0.120	
2-38	13.0	10	0.20	0.048	
2-39	13.2	12	0.17	0.034	
2-40	13.4	18	0.20	0.027	
2-41	13.7	15	0.20	0.032	
2-42	14.0	15	0.19	0.030	
2-43	14.2	15	0.17	0.027	
2-44	14.5	15	0.16	0.026	
2-45	14.7	15	0.18	0.029	
2-46	15.0	12	0.20	0.040	
2-47	15.2	15	0.16	0.026	
2-48	15.4	9	0.08	0.021	
2-49	15.6	15	0.16	0.026	
2-50	15.9	15	0.14	0.022	
2-51	16.1	15	0.13	0.021	
2-52	16.4	15	0.10	0.016	
2-53	16.7	15	0.09	0.015	

More samples were collected but all were below 0.001  $\mu\text{c}/\text{cu m}$ , as shown from standard activity samples and air collection rates.

TABLE 7.4 SHOT & BETA ACTIVITY ON THE FLYING BRIDGE OF THE YAG 40

Sample Number	Mean Time of Collection After $t_0$ (hr)	Sample Strength at $t_0 \pm 1750$ hr x $10^{-9}$ Curies	Theoretical Multiplier (Approx.)	Estimated $\mu\text{c}/\text{cu m}$ at Collection
5-8	0.2	0.89		
5-9	0.7	0.31		
5-10	1.2	1.70	3100	0.44
5-11	2.2	2.24(a)	2350(a)	0.44
5-12	2.2	3.76(a)	1800(a)	0.57
5-13	2.7	1.05	1300	0.11
5-14	3.2	0.05	1120	0.01
5-15	3.7	0.05	1000	0.00
5-16	4.2	0.10	900	0.01
5-17	4.7	0.00	830	0.00
5-18	5.2	0.10	770	0.01
5-19	5.7	0.68(a)	835(a)	0.05
5-20	6.2	0.10	685	0.01
5-21	6.7	1.75	640	0.09
5-22	7.2	0.90	610	0.05
5-23	7.7	1.85	570	0.09
5-24	8.2	2.54(a)	630(a)	0.13
5-25	8.7	3.25	515	0.14
5-26	9.2	2.32(a)	565(a)	0.11
5-27	9.7	2.90	465	0.11
5-28	10.2	2.10	455	0.08
5-29	10.7	2.05	440	0.08
5-30	11.2	2.20	425	0.08
5-31	11.7	1.41(a)	460(a)	0.05
5-32	12.2	2.10	395	0.07
5-33	12.7	1.36(a)	430(a)	0.05
5-34	13.2	1.50(a)	415(a)	0.05
5-35	13.7	2.68(a)	405(a)	0.09
5-36	14.2	3.10	351	0.09
5-37	14.7	2.80	342	0.08
5-38	15.2	1.75	333	0.05
5-39	15.7	1.41(a)	365(a)	0.04
5-40	16.2	0.15	317	0.00
5-41	16.7	0.15	310	0.00
5-42	17.2	0.15	303	0.00
5-43	17.7	0.55	296	0.01
5-44	18.2	0.50	289	0.01
5-45	18.7	1.90	283	0.04
5-46	19.2	0.20	277	0.00
5-47	19.7	0.10	271	0.00
5-48	20.2	1.10	265	0.02
5-49	20.7	0.95	260	0.02
5-50	21.2	1.60	255	0.03

Sample Number	Mean Time of Collection After $t_0$ (hr)	Sample Strength at $t_0 \pm 1750$ hr x $10^{-9}$ Curies	Theoretical Multiplier (Approx.)	Estimated $\mu\text{c}/\text{cu m}$ at Collection
5-51	21.7	1.35	250	0.03
5-52	22.2	2.10	245	0.04
5-53	22.7	1.15	240	0.02
5-54	23.2	0.85	235	0.02
5-55	23.7	0.65	230	0.01
5-56	24.2	0.55	225	0.01
5-57	24.7	1.30	220	0.02
5-58	25.2	0.60	215	0.01
5-59	25.7	0.40	210	0.01
5-60	26.2	1.35	205	0.02
5-61	26.7	0.80	200	0.01
5-62	27.2	1.15	196	0.02
5-63	27.7	0.90	193	0.01
5-64	28.2	1.00	190	0.02
5-65	28.7	0.60	187	0.01
5-66	29.2	0.85	184	0.01
5-67	29.7	0.65	181	0.01
5-68	30.2	0.90	178	0.01
5-69	30.7	0.50	175	0.01
5-70	31.2	1.55	172	0.02
5-71	31.7	0.80	169	0.01
5-72	32.2	0.65	166	0.01
5-73	32.7	1.65	163	0.02
5-74	33.2	1.10	160	0.02
5-75	33.7	15.05	157	0.20
5-76	34.2	0.70	155	0.01
5-77	34.7	2.80	153	0.04
5-78	35.2	0.60	151	0.01
5-79	35.7	0.35	149	0.00
5-80	36.2	0.40	148	0.00
5-81	36.7	0.22	147	0.00
5-82	37.2	1.89	146	0.02
5-83	37.7	0.89	144	0.01
5-84	38.2	0.33	142	0.00
5-85	38.7	1.00	140	0.01
5-86	39.2	0.22	138	0.00
5-87	39.7	0.61	136	0.01
5-88	40.2	6.72	134	0.08
5-89	40.7	0.61	132	0.01
5-90	41.2	1.72	131	0.02
5-91	41.7	0.33	130	0.00

(a) Beta activity determined at  $t_0 \pm 1875$  hr.

occurrence of airborne contamination may perhaps be used to infer the forthcoming buildup of gamma emitter.

The mechanical and electrical features of the two monitors operated very well and can be depended upon in any later design of the change mechanism and the timing arrangements.

In practice it was found that the coincidence circuit was not satisfactory. The tubes were received from the manufacturer too short a time before being put into the detector to make a proper study of their characteristics. They were found to receive too much gamma radiation to

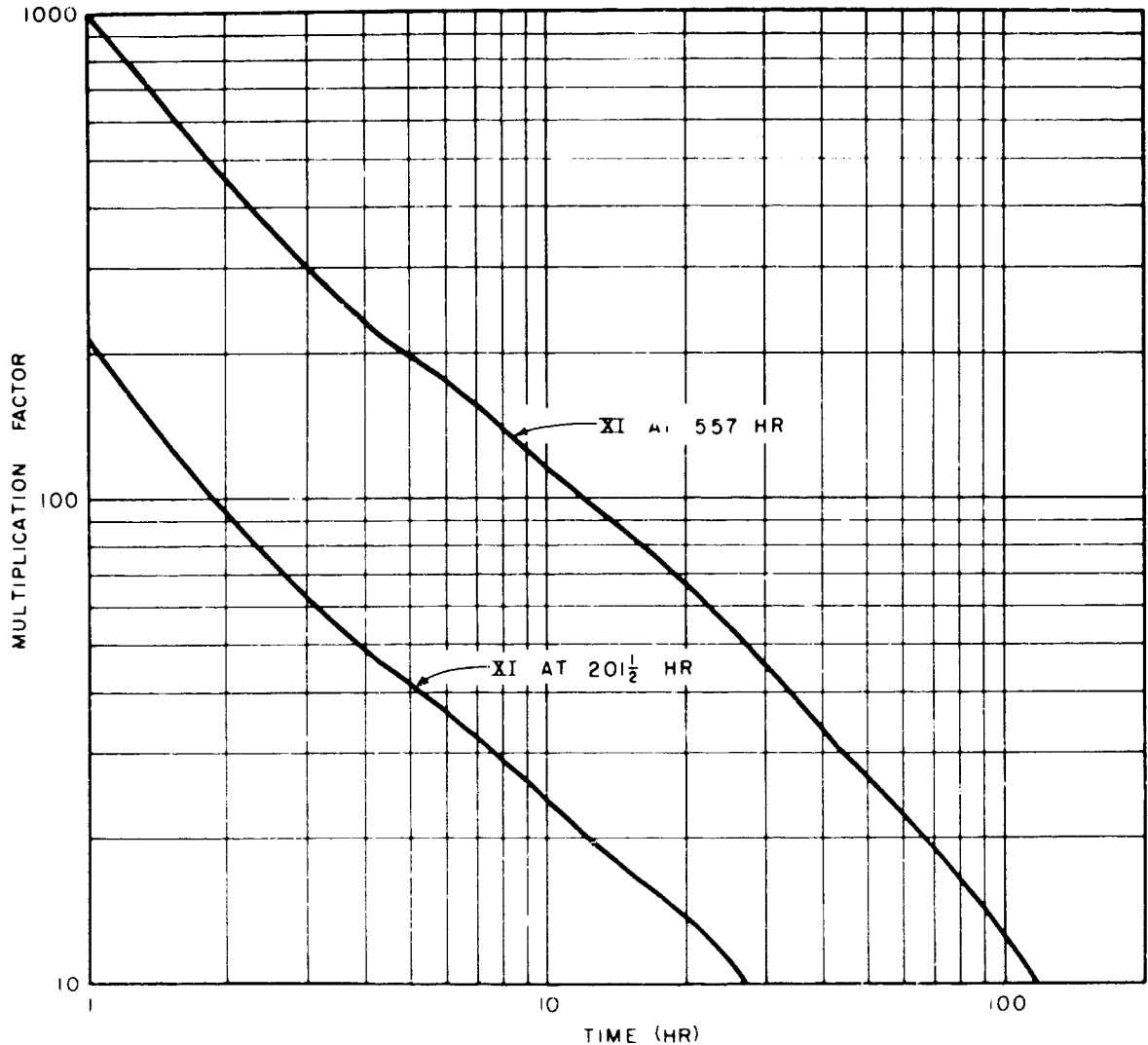

Figure 7.1 Theoretical beta decay curves for Shots 1 and 2

allow sufficient operating time for true coincidences to occur when simultaneous beta traces activated them. In the field, the coincidence feature was abandoned in both installations; hence, the alarm system was not operative since it was triggered by a signal from the detector. Instead of the coincidence system, a single tube surrounded with lead was operated directly into a Nuclear 1015B ratemeter and, thence, to an Esterline-Angus recorder. Such an instrument should be useful in roentgen fields of 0.5 r/hr background, as shown by shielding ratios with lead, particularly if a simple method for inserting a beta-calibration source in the counting head can be devised.

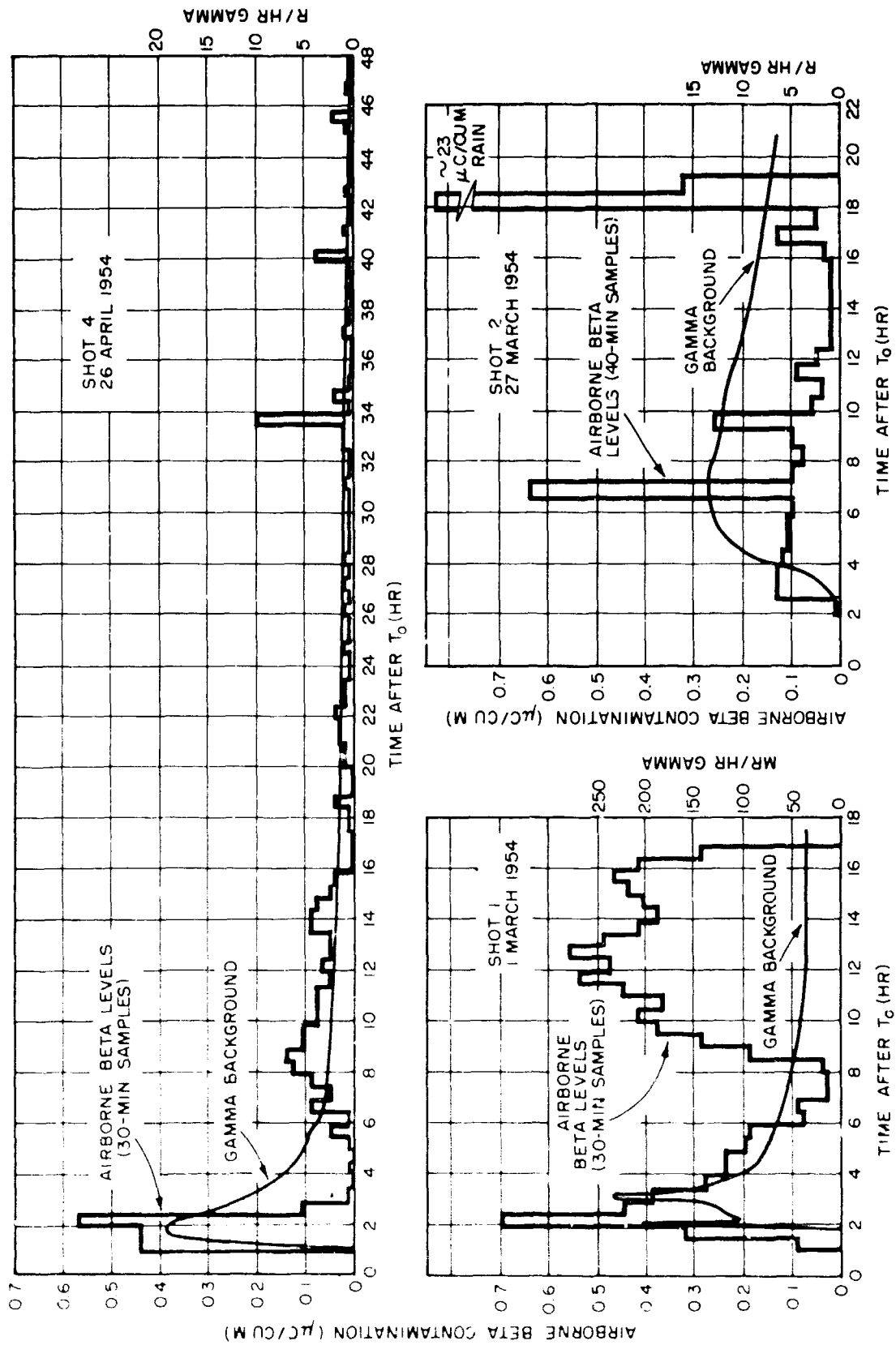

Figure 7-2 Airborne beta contamination at the flying bridge of the YAG 40 at collection time.

## 7.6 CONCLUSIONS

It is concluded that determination of beta-activity on a filter paper cannot be managed in fields greater than 0.5 r/hr without redesign of the shielding to reduce the intensity of scattered radiation reaching and saturating the Geiger tubes used as sensitive detectors. In low-background regions, however, the combination of single tube with adequate shielding and ratemeter-recorder combination can be used as a meter-warning device, which easily indicates the presence of  $10^{-9}$  curies of beta activity per cubic meter of air (see Table 7.3 footnote). Such a device, when combined with the mechanical and electrical paper change system, gives satisfactory warning of the presence of beta-emitter or

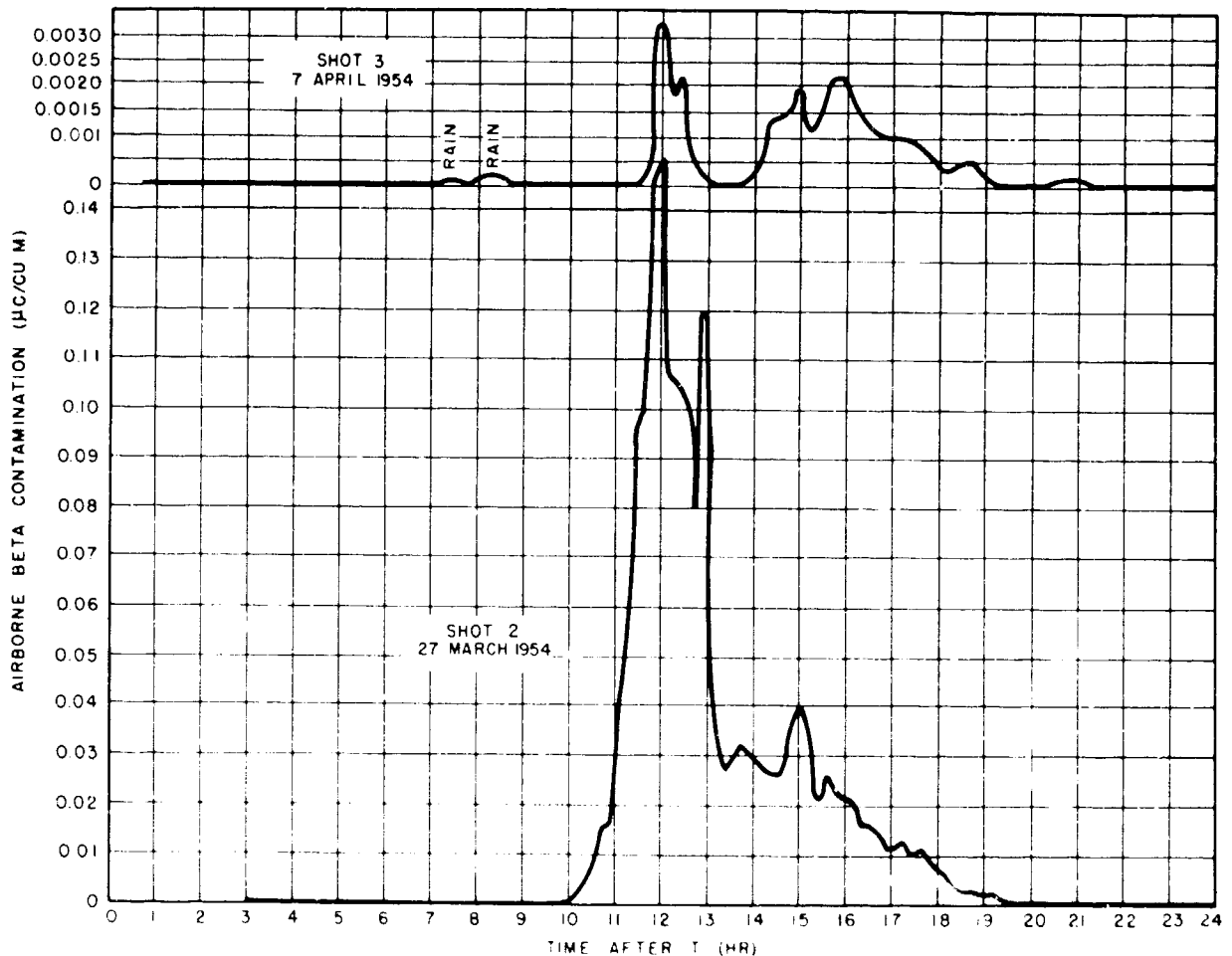

Figure 7.3 Airborne beta contamination at Site Elmer at collection time.

incipient buildup of gamma-emitter in regions where gamma background is less than  $\frac{1}{2}$  r/hr.

## 7.7 RECOMMENDATIONS

Before the air-monitor with the early warning feature can be considered satisfactory for use in relatively high fields, some further work should be done on the detector system to diminish its sensitivity to low-energy scattered radiation or to high-energy transmitted gamma intensity. Methods for studying the tubes and the effect of a proper disposition of baffles have been planned.

## Chapter 8

# INSTRUMENTATION

M. I. Lipanovich      H. A. Zagorites  
K. F. Sinclair        H. Bright  
D. W. Berte

The shipboard gamma system is used, in conjunction with a data reduction system, to provide long-term continuous information relative to radiation fields. The instrument consists of a series of ionization chambers, associated electrometer and relay circuitry, and Esterline-Angus pen-type operational recorders. The system is the autorecycle type; so that, as each increment of radiation is received and recorded, the chamber is recharged to its original voltage. The information for each chamber is stored as a simple pulse, each pulse corresponding to the basic increment of gamma radiation for the given chamber. The basic chamber increments are 0.1 mr, 10 mr, 1 r, and 100 r, thus, covering the range from 0.1 mr/hr to 10,000 r/hr if one chamber of each type is used.

The data-reduction apparatus is used to convert the recorded data, which are discontinuous analog information, into continuous analog plots of accumulated dose and dose rate as functions of time. The accumulated dose and dose rate can be plotted as linear or logarithmic functions with linear or logarithmic time bases.

### 8.1 OBJECTIVE

The purpose of the instrumentation phase of Project 6.4 was to provide a system for obtaining simultaneous information relative to accumulated gamma dose and gamma dose rate at a large number of stations located over a wide area. Test needs required that the system operate unattended for days and, also, that it provide a permanent record of the gamma-field conditions. An auxiliary purpose of the instrumentation system was to furnish supplementary data for certain other projects of Operation Castle.

### 8.2 PRELIMINARY SPECIFICATIONS

Uncertainty of some of the experimental conditions dictated many of the specifications for the instrumentation system. First in importance was the curve of cumulative dose versus time, for which the system had to provide cumulative dose of  $10^6$  r. Furthermore, the system had to provide a plot of dose rate versus time, in which dose rates ranging from 0.1 mr/hr to 36,000 r/hr were measured. This upper limit was later reduced to 10,000 r/hr. An accuracy of 1 percent was originally specified for the instrumentation system.

To cover adequately the test area, 137 instrument stations were specified. In addition, three stations were installed adjacent to the instruments used for Project 2.5a to correlate Project 6.4 data with those from Project 2.5a. Since many of the locations were in exposed areas, suitable coverings had to be provided to protect the instruments from the weather. These coverings also served as a beta shield, so that the instruments responded only to gamma radiation. The instrument stations were exposed to ambient temperatures ranging from 50°F to 120°F and relative humidity of 90 percent.

Design of the power supply was based on a nominal 6-month duration for the test and unattended 12-day operating periods.

Reliability was the keynote in the design of the instrumentation system. Precautions were taken so that failure of any one instrument did not interfere with another. Separate power sources and recorders were used where they were feasible. Providing means of avoiding misleading results due to local contamination was explored throughout the planning of the instrumentation systems.

### 8.3 METHOD OF ATTACK

In the instrumentation system, autorecycling ion chambers were used to gather the large amount of data in discontinuous analog form, and a data-reduction apparatus (DRA) was devised to reduce it to a continuous function. The ion chambers were designed to recycle after receiving a predetermined cumulative dose. A recorder indicated when the recycling occurred. Because the gamma dose rates ranged from 0.1 mr/hr to 10,000 r/hr, each instrument required four ion chambers. Each of these provided information over 2 decades. Some overlap between ranges was provided to allow cross calibration and permit the data to be normalized when necessary. The recorders were pen-and-ink type. Parallel recording of the detectors comprising a station was provided to insure against loss of data due to failure of the recorder.

The DRA was devised to perform two types of computations and plot the required curves. It computed the cumulative dose by summing and weighting the recorded dose increments and computed the dose rate by measuring the time between recorded pulses. The time between recorded pulses was inversely proportional to the dose rate.

Design and development considerations leading to the adoption of this method of attack on the instrumentation problem are discussed in Appendix F.

### 8.4 DESCRIPTION OF THE INSTRUMENTATION SYSTEM

The extent of the instrumentation system is indicated in Figure 8.1, which shows the station locations on the two test ships.

The instrumentation system consisted of two parts: the gamma recording instruments and the DRA. The DRA was set up and used at the site, then dismantled and returned to NRDL, where it was used to complete the analysis of the data from Project 6.4.

#### 8.4.1 Gamma-Recording Instruments. The gamma-recording instruments

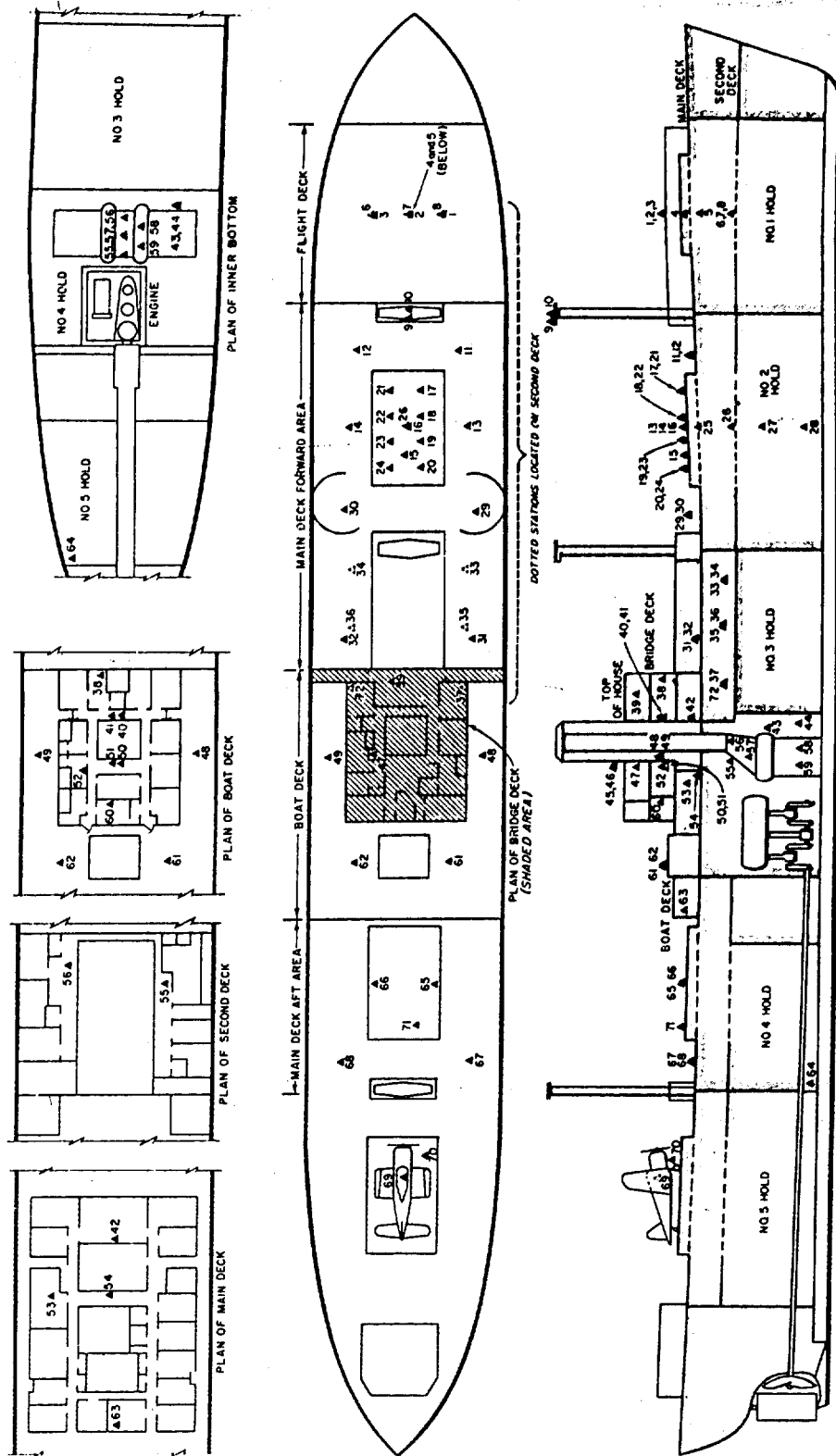

Figure 8.1 Gamma-detector stations aboard the test ships.



consisted essentially of a large number of similar units, each having an ionization chamber, an electrometer circuit, a power amplifying device, and a recorder. Figure 8.2 is a schematic diagram of a gamma field recording instrument. As is evident from this diagram, the instrument is an autorecycling, integrating, ionization chamber system. A type 5800 tube is used as a conventional inverted triode. The input element

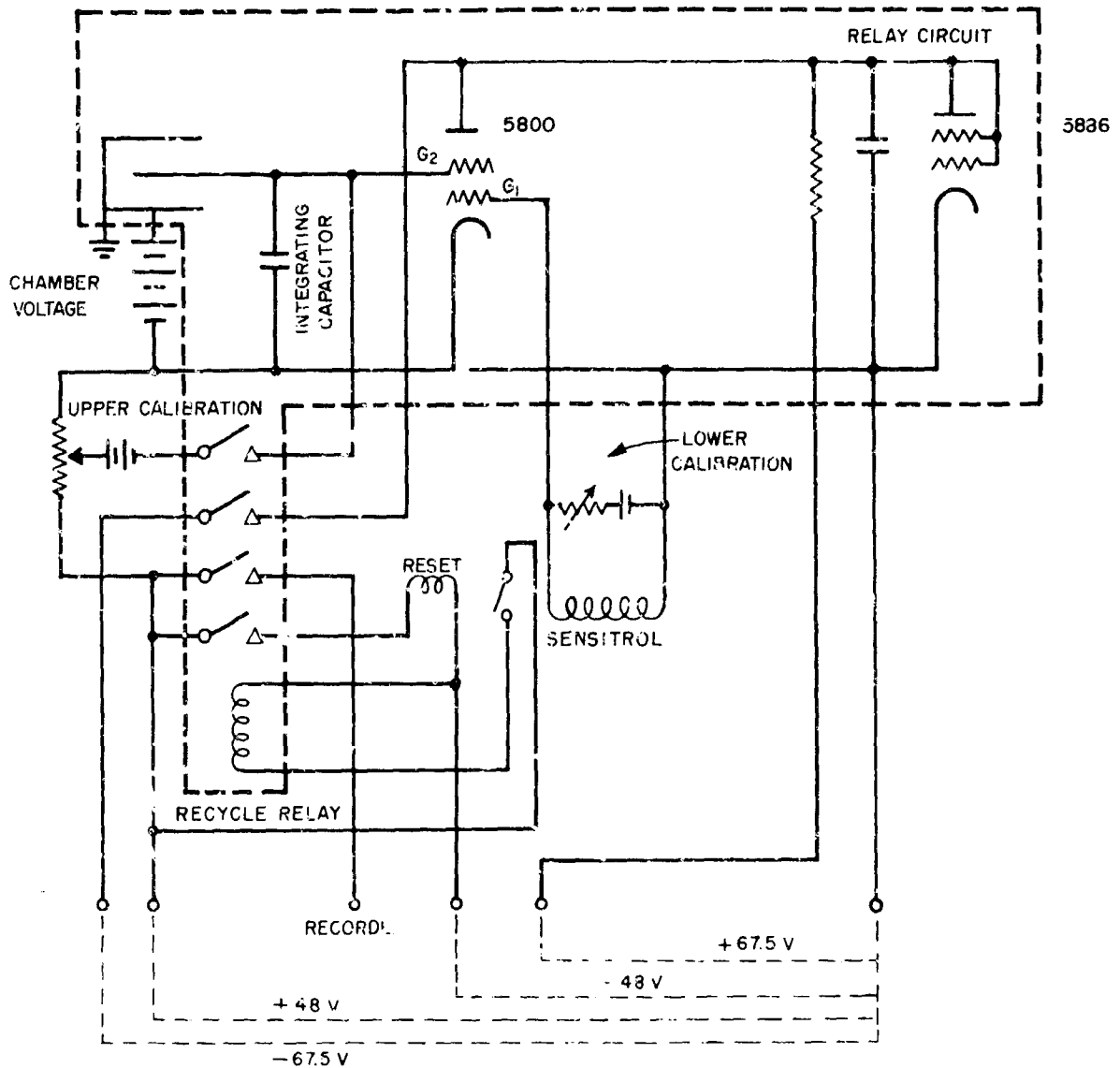

Figure 8.2 Simplified schematic of the gamma-detector channel.

is  $G_2$ , and the output current signal is taken from  $G_1$ . The Sensitrol,<sup>1</sup> a meter movement-type relay is the power amplifying device. The Sensitrol is biased by a back current set by the lower calibration adjustment. This back current determines the output current from the electrometer required to energize the 5- $\mu$  amp Sensitrol. The recycle relay<sup>2</sup> is shown in Figure 8.3. The Sensitrol energizes the recycle relay, which in turn energizes the recorder momentarily, recharges the ion chamber through the

<sup>1</sup> Mfg by Weston Electrical Instrument Corporation, Newark, N. J.

<sup>2</sup> Mfg by Potter-Brumfield Manufacturing Company, Princeton, Indiana.



Figure 8.3 The recycle relay.

special coiled spring contact, resets the Sensitrol, and charges the delay capacitor. The potential of the delay capacitor is applied to the plate of the electrometer. The electrostatic field generated by this plate prohibits current from flowing to the output tube element, regardless of the potential on  $G_2$ . The delay capacitor discharges through the delay resistor and requires about 7 sec to reach a potential sufficiently low that output current can flow in the electrometer tube. The 5886 tube clamps the electrometer tube plate at zero volts after the delay capacitor has discharged to permit proper inverted triode operation in the electrometer.

To cover a range of 0.1 mr/hr to 10,000 r/hr required four ionization chambers at each station. These chambers were designated A, B, C, and D and had increments of 0.1 mr, 10 mr, 1 r, and 100 r, respectively.

The differences between the detectors were chamber volume, gas pressure, and size of the integrating capacitor. Table 8.1 lists these differences. The capacitors in the B, C, and D chambers were accurate to within  $\pm 1$  percent. The A detector depended upon stray capacities, which were not so accurately maintained. A radiological calibration of each chamber showed that 1 percent accuracy could not be obtained, if identical swing voltages were employed, because of slight differences in chamber pressures.

TABLE 8.1 CHARACTERISTICS OF THE ION CHAMBERS

Detector	Chamber			Integrating Capacitor
	Volume	Pressure (atm)	Gas	
A	1.2 liters	10	98% N <sub>2</sub> ; 2% He	10 $\mu$ f
B	1.2 liters	2	98% N <sub>2</sub> ; 2% He	100 $\mu$ f
C	1.2 liters	2	98% N <sub>2</sub> ; 2% He	0.01 $\mu$ f
D	8 cc	2	98% N <sub>2</sub> ; 2% He	0.01 $\mu$ f

The swing voltage is that voltage across the chamber and integrating capacitor that is discharged by the chamber current. Increasing the swing voltage increases the charge required to discharge the chamber and capacitor, thereby increasing the instrument increment. To compensate for differences in chamber pressures and stray capacities, a different swing voltage was used for each chamber, so that the increments were accurate within  $\pm 1$  percent. The swing voltage is adjusted by means of the upper calibration adjustment.

Although each detector covered two decades of information, all detectors were continuously recorded. The maximum recycle rate at which information was to be used was 1 cycle every 10 sec. The 7-sec dead time caused by the delay circuitry gave a sufficient margin of safety to permit usual variations in components of standard commercial accuracy. When one chamber was recycling once every 10 sec, the next higher chamber recycled once every 1,000 sec (16.7 min). This arrangement gave data points with sufficient frequency, yet did not require an unduly large number of detectors.

The gamma instruments were installed as two units: the detectors were mounted at the test points and the control units were placed at some distance in an air-conditioned room. The two sizes of detectors are shown in Figure 8.4; detectors A, B, and C were the same size, and D was much smaller. The portion of the electronics in Figure 8.2 shown within the dotted line was contained within the detector housing. The electronics mounted on the detector base plate are shown in Figures 8.5 and 8.6. The lead cylinder shown in the latter figure contains the integrating capacitor. This lead shield was required, because the capacitor leakage resistance diminished in radiation fields. The teflon center post made contact to the chamber collecting electrode.

A typical detector installation, with and without the protective dome, is shown in Figures 8.7 and 8.8. The chambers were sealed, and a short length of cable was brought out through the base plate. A 12-wire cable connected the detector to the control unit. The latter figure also shows the polyethylene beta shield used on each detector. This shield



Figure 8.4 Two sizes of the four detectors; A, B, and C were the larger ones, D, the smaller.

was  $\frac{1}{4}$ -in. thick.

The energy response to the detectors is shown in Figures 8.9 and 8.10. The low energy response of A differs from that of B and C because of chamber wall thickness. Chamber A was filled to 10 atmospheres and required a  $\frac{1}{16}$ -in. aluminum wall; chambers B and C had  $\frac{1}{32}$ -in. aluminum walls. Chamber D was covered with 0.006-in. lead foil to improve

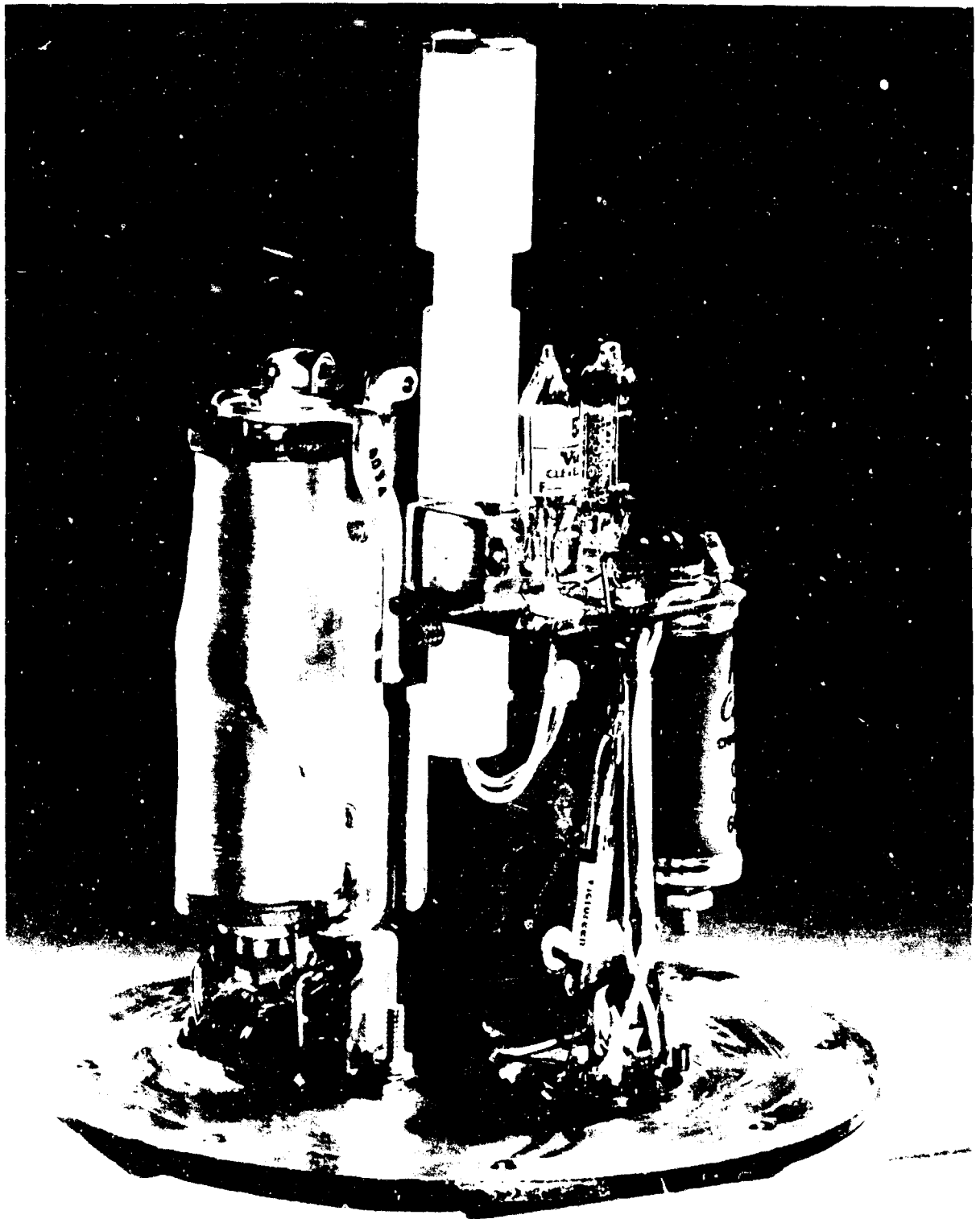

Figure 8.5 Detector electrometer assembly showing main relay and teflon-insulated center post.

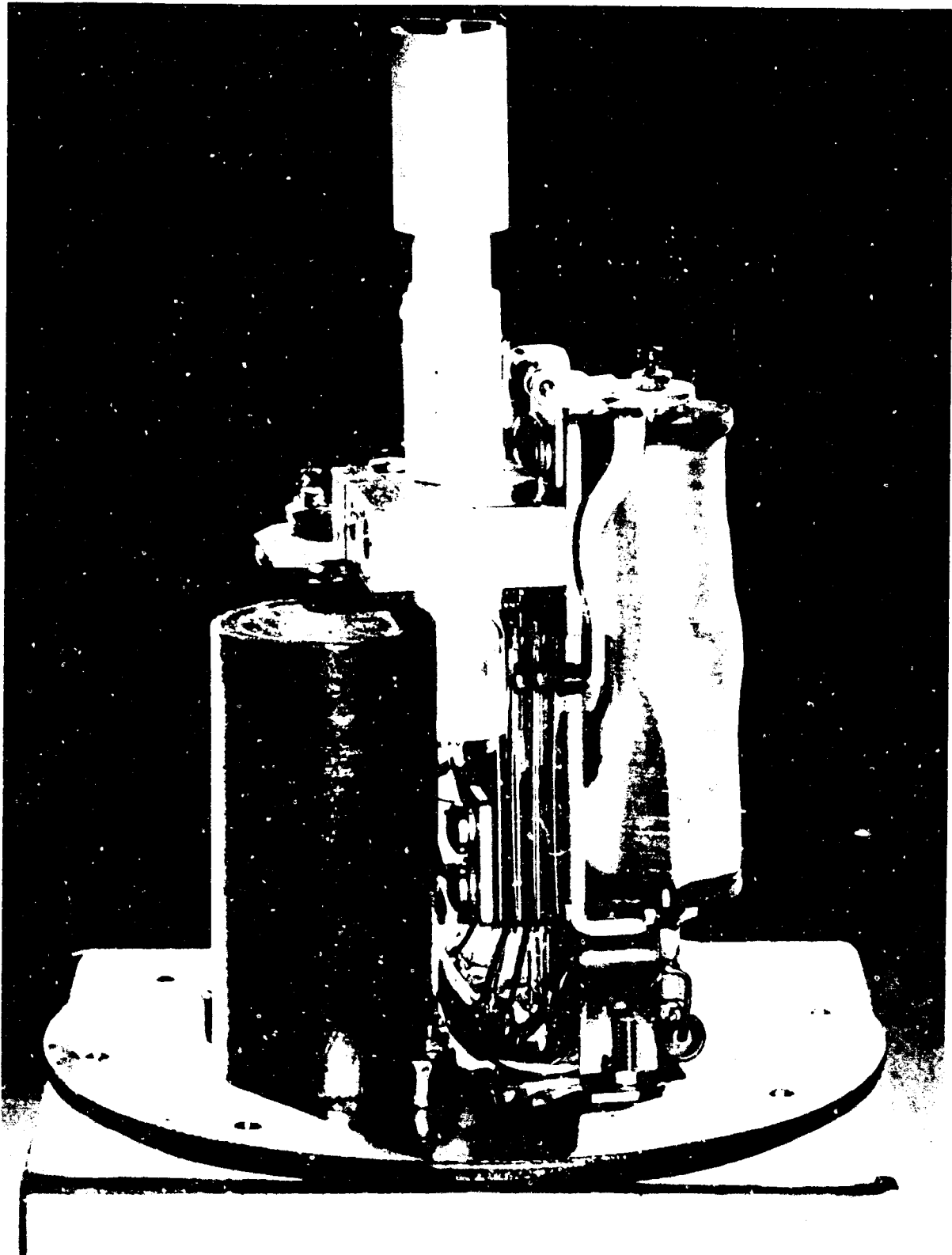

Figure 8.6 Detector electrometer assembly showing the lead-covered integrating capacitor.

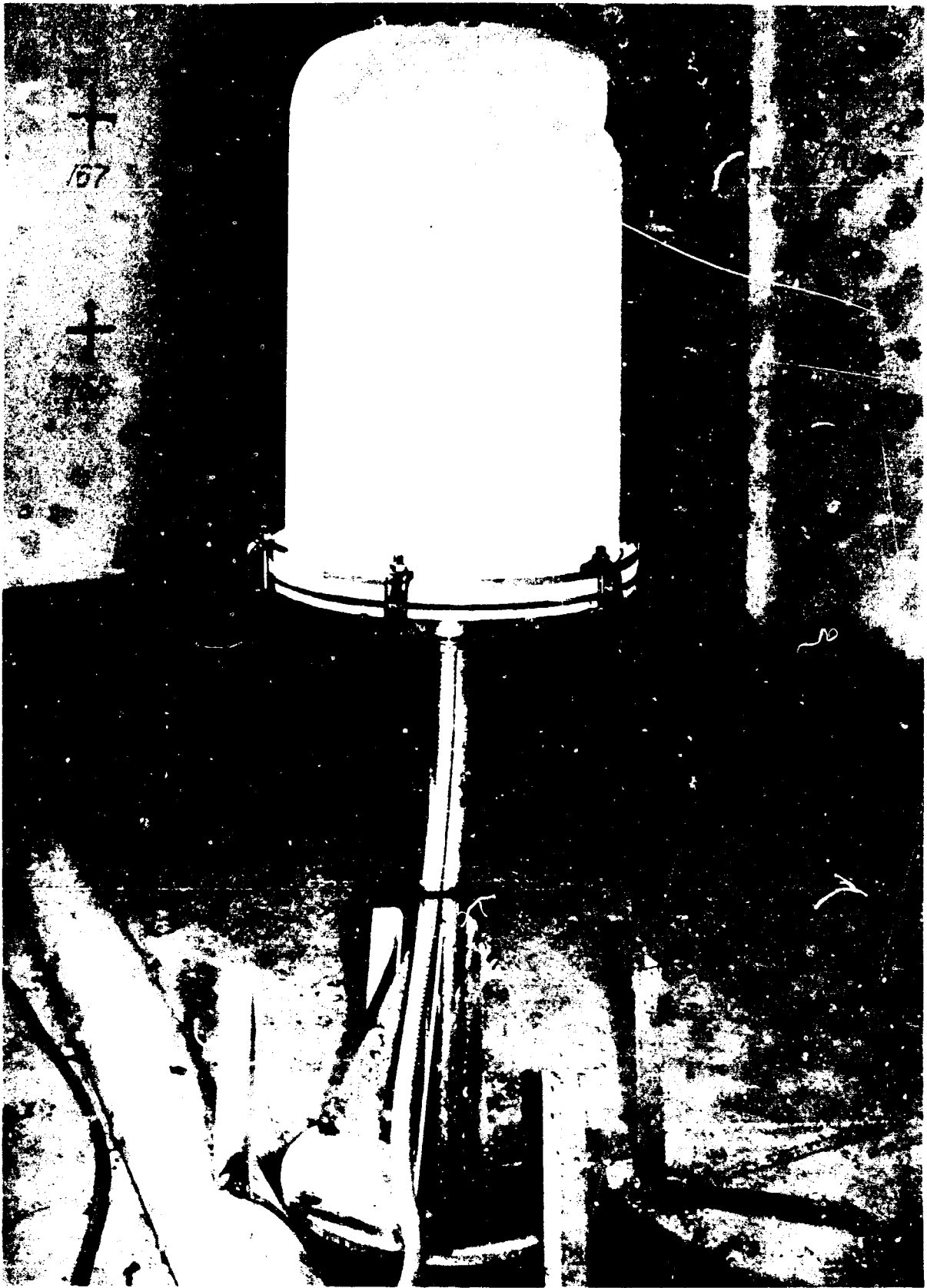

Figure 8.7 Typical below-deck gamma detector with lucite dome cover.

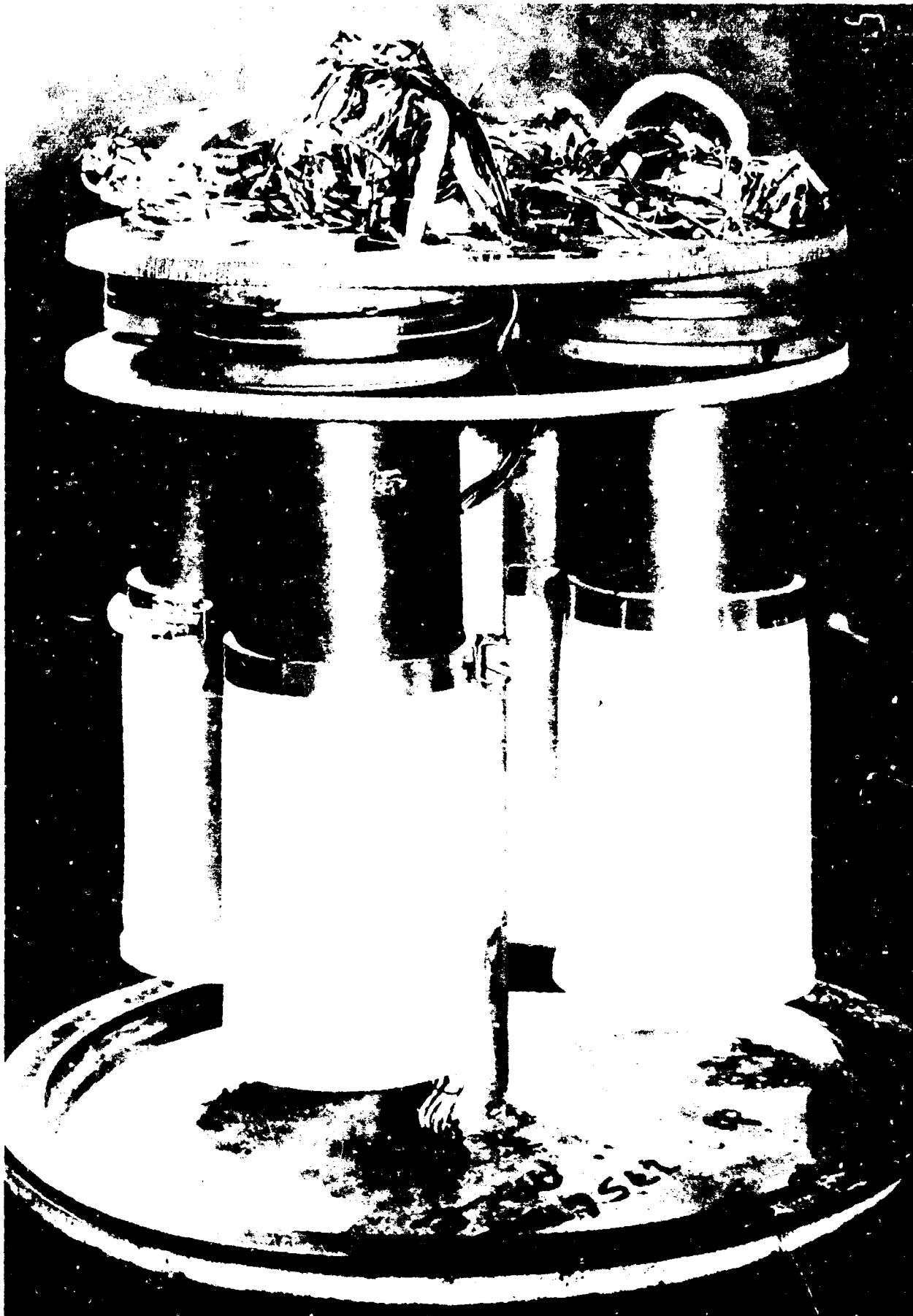

Figure 8.8 Typical below-deck gamma detector with cover removed.



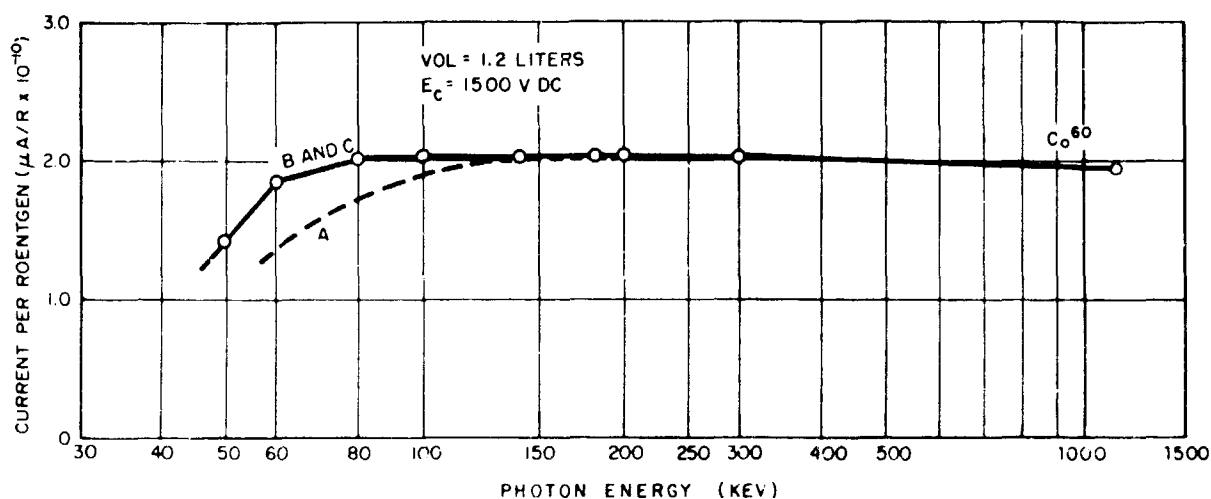

Figure 8.9 Low energy response of detectors A, B, and C.

the energy response of this detector.

The control units were mounted in an air-conditioned room, together with the recorders. Four control units were mounted in a horizontal row for the four detectors of a station. Five such rows were contained in any single control-unit assembly. The groups of fuses on the right of the front panel were common to all detectors in a station. Each channel had a separate filament switch. A telephone-type jack was used in the electrical calibration of a channel. A calibrating unit was plugged into the jack, so that the Sensitrol bias current and the swing voltage could be measured and adjusted. A 60-wire cable was used to interconnect each station. All components except batteries were mounted on the hinged front panel of the assembly; dry batteries were contained in the rear.

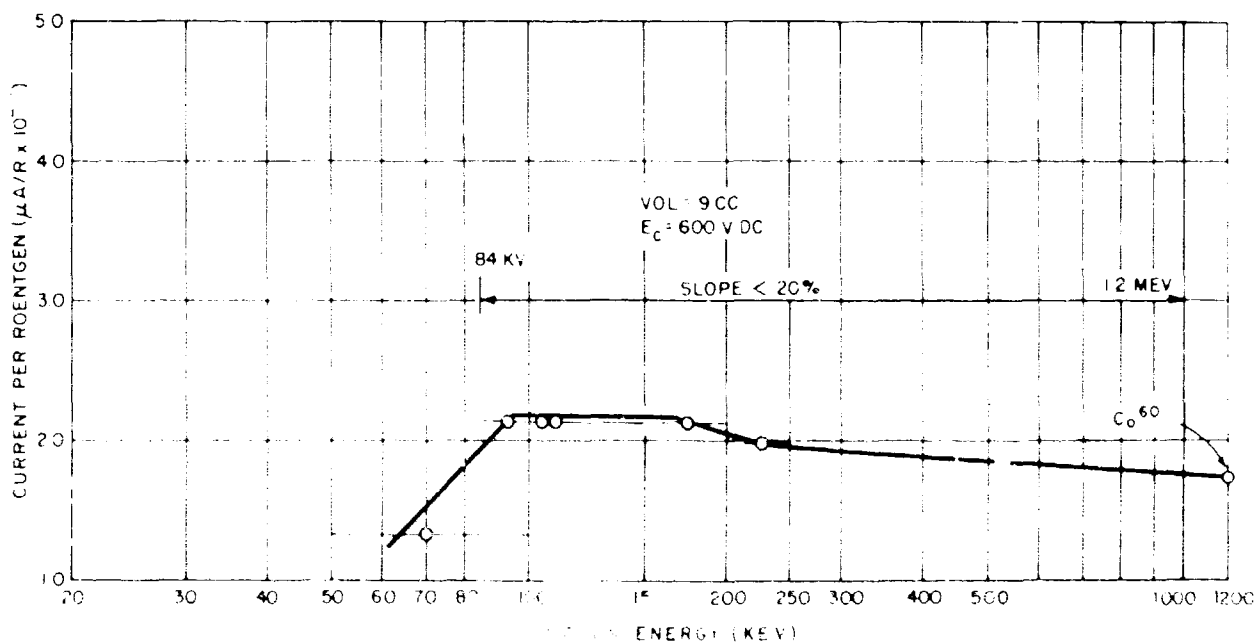

Figure 8.10 Energy response of detector D.

The 20 pen-and-ink type recorders<sup>1</sup> were used. Two recorders were mounted in a single case. Each recorder accommodated five detector stations. Since some stations did not use four basic detectors because of limited range requirements at their locations, all recorders had at least one unused channel. The recording pens were energized by solenoids. When these are energized, the pen moves to the right. Since the pens were energized momentarily, the record was a trace with pulses indicated on the right side. Figure 8.11 shows a typical recorder chart.

The recorders required 48 v direct current for their operation.

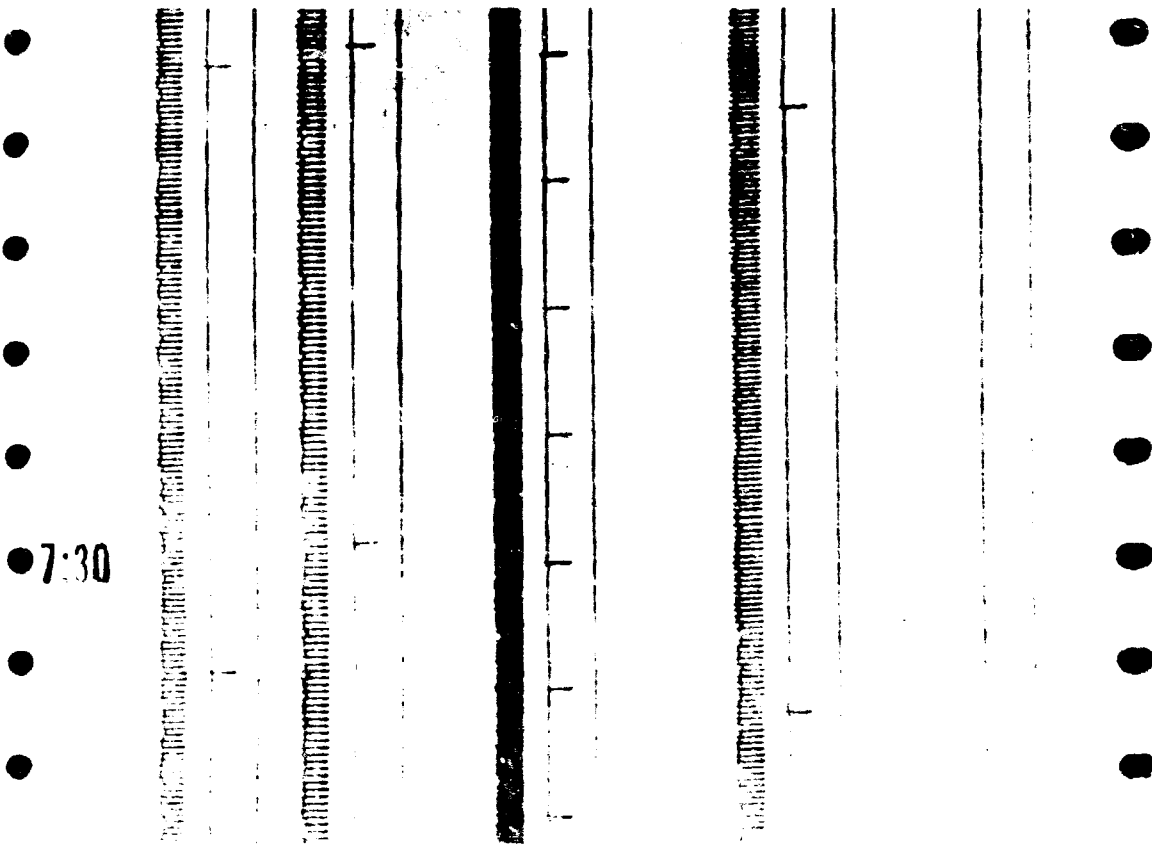

Figure 8.11 Typical recorder chart.

Because the current requirements were too heavy for dry batteries, lead-acid storage batteries were used. Lead-acid storage batteries were also used for electron tube filament power. Six-volt batteries were used, and a resistor was placed in series with the tube filaments. This resistor gave some filament regulation. A battery charger used to trickle charge both the 48-v and 6-v battery banks whenever alternate current power was available.

Figure 8.12 shows two racks of equipment in the control unit or recorder room. The trickle chargers are at the top. One 48-v and one 6-v battery bank served as power sources for two control-unit assemblies. Consequently, one charger per rack was sufficient. Two control-unit assemblies and two recorders occupied the rest of the rack. Some of the Sensitrols masked off in the figure are for unused detector channels at various stations, others indicate faulty Sensitrols. Figure 8.13 shows all the control-unit racks in the control room. The two racks in the

<sup>1</sup> Mfg by Esterline-Angus Company, Inc., Indianapolis, Indiana.

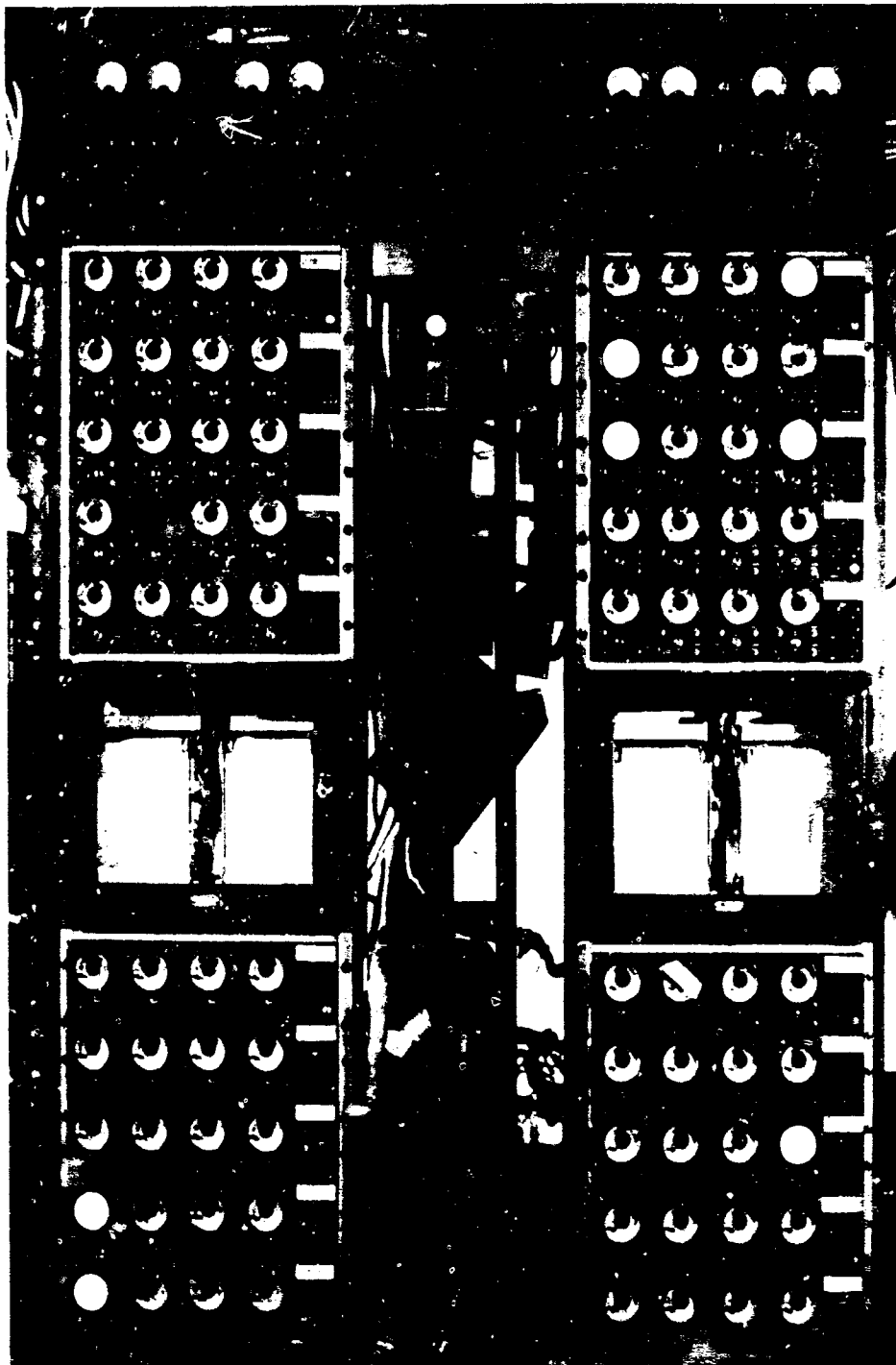

Figure 8.12 Two complete instrument rack installation.  
Top, charger power panel. Below, upper control assembly,  
recorder and lower control assembly.

foreground contain spare recorders used to obtain duplicate records of all data.

The system recorded all data in duplicate.

8.4.2 Data-Reduction Apparatus (DRA). Since the amount of data collected by the gamma-field recording instruments was too large to reduce by manual means, the data-reduction apparatus was developed to

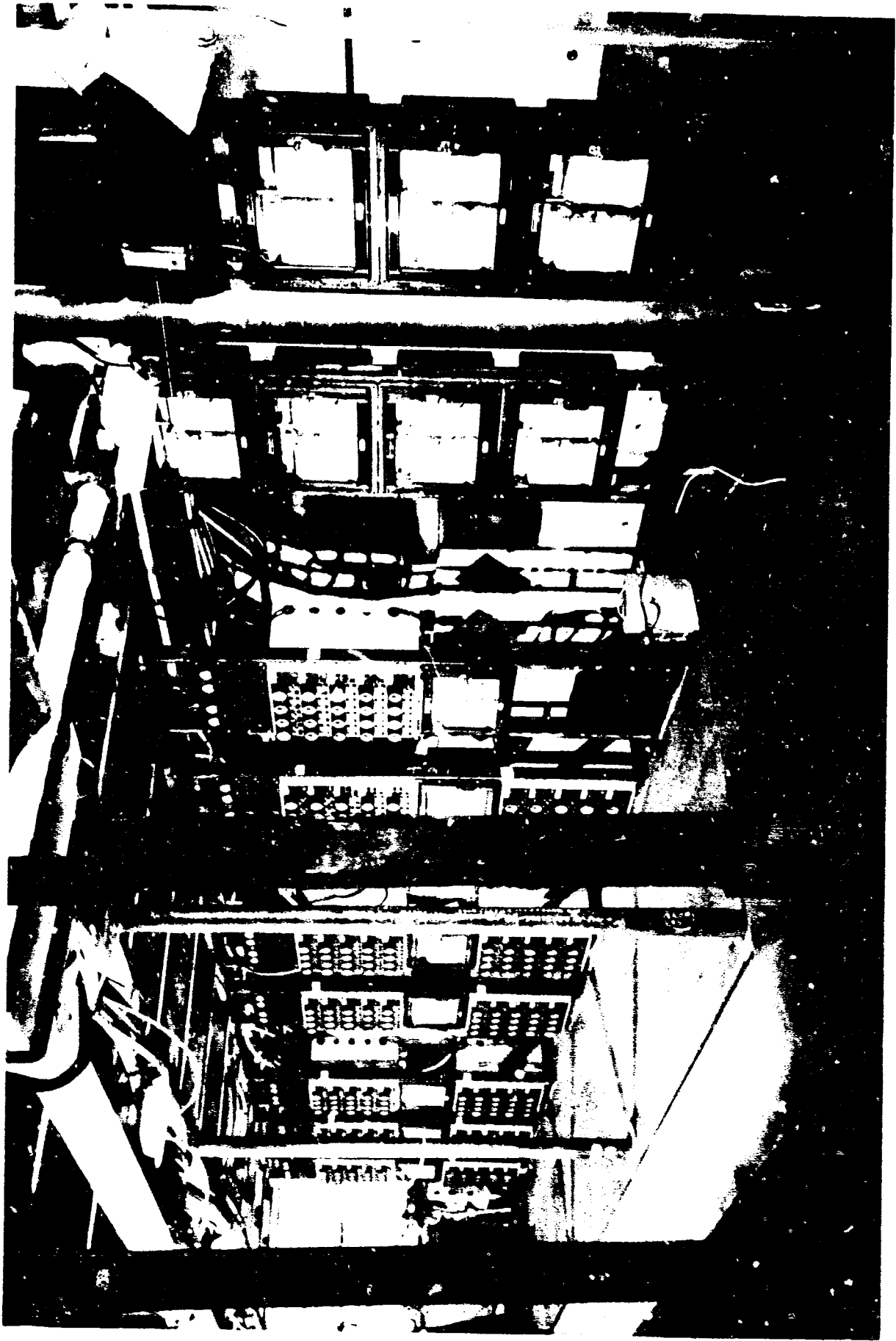

Figure 8.13 Complete recorder-room installation.  
Duplicate recorders are mounted in the two racks  
at the right.

reduce the raw data mechanically. A simplified block diagram of the DRA is shown in Figure 8.14. The raw data on the input tapes are converted into electrical impulses by the photoelectric system in the tape reader. The desired station is selected by choosing the appropriate group of traces in the 20-channel patch panel. The two to four signals chosen are amplified and shaped in the control unit, where rate-scale selection, with or without prescaling, is made and the decimal multiplier coded pips are produced. The dose unit automatically integrates and weights raw input data, yielding both linear and logarithmic dose data for curve plotting.

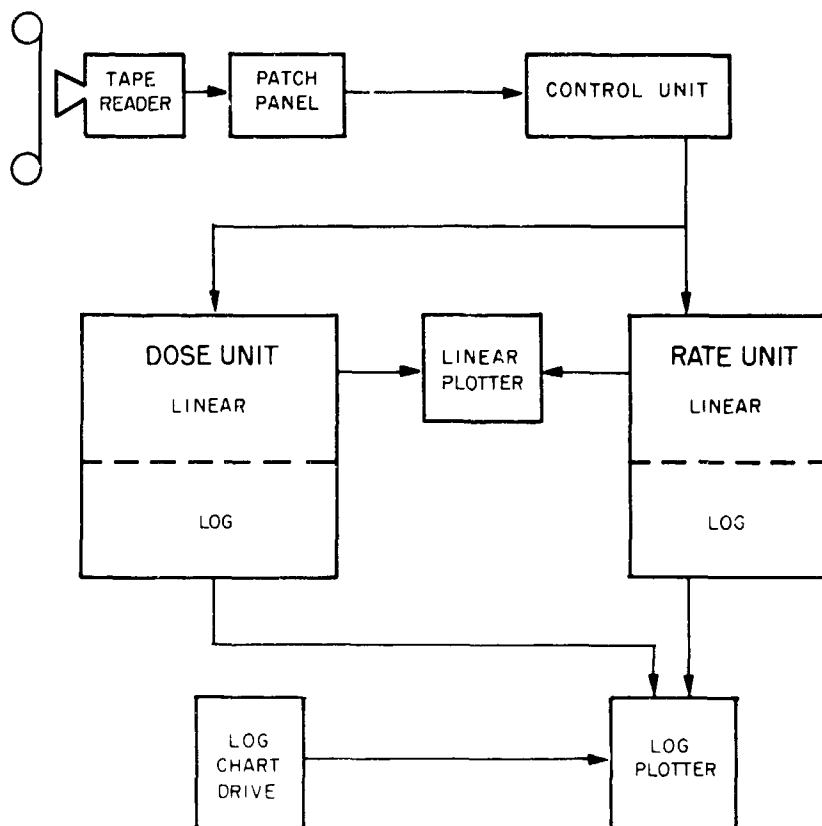

Figure 8.14 Simplified block diagram of the data-reduction apparatus.

The rate unit computes the normalized reciprocal of time between pulses, producing both linear and logarithmic dose rate data for curve plotting. The log time base generates a resistance signal for the time axis of an X-Y plotter, which is linear with the logarithm of time over 3 decades that cover 1 hr of computing time. The 1 hr of computing time equals 100 hr of actual time. The charts in the recorder are 100 ft long and move at 1 ft/hr. The 100-to-1 speed-up was the maximum practical limit of this ratio. Figure 8.15 shows a front view of the DRA.

The tape reader and patch panel are shown in Figure 8.16. The drive mechanism is a modified Esterline-Angus recorder having a high-speed electric drive. The chart passes through the photoelectric readout where transmission optics are used to read 20 traces simultaneously, thereby avoiding mechanical design complications. The traces are illuminated by 20 tiny surgical lamps set behind a cylindrical focusing lens and slit. Type 1 P 42 phototubes are used as the photoelectric transducer. The

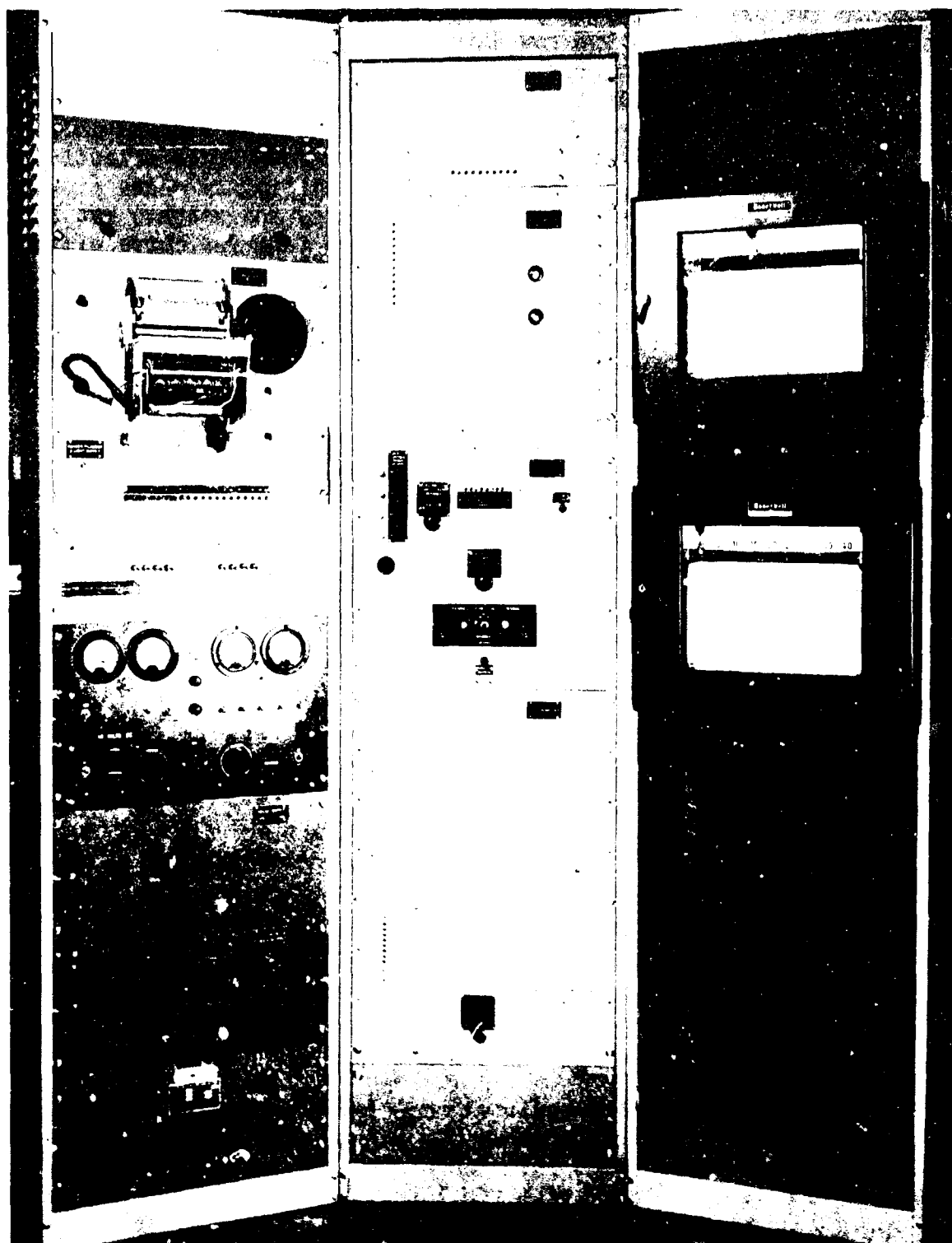

Figure 8.15 Front view of the data-reduction apparatus.  
The control unit is the third panel down in the middle rack.

output of these tubes drive individual cathode followers, using 10 sub-miniature dual triodes (CK 6111). The outputs of the cathode followers are electrically equalized.

The patch panel is a 20-cable standard telephone switchboard strip.

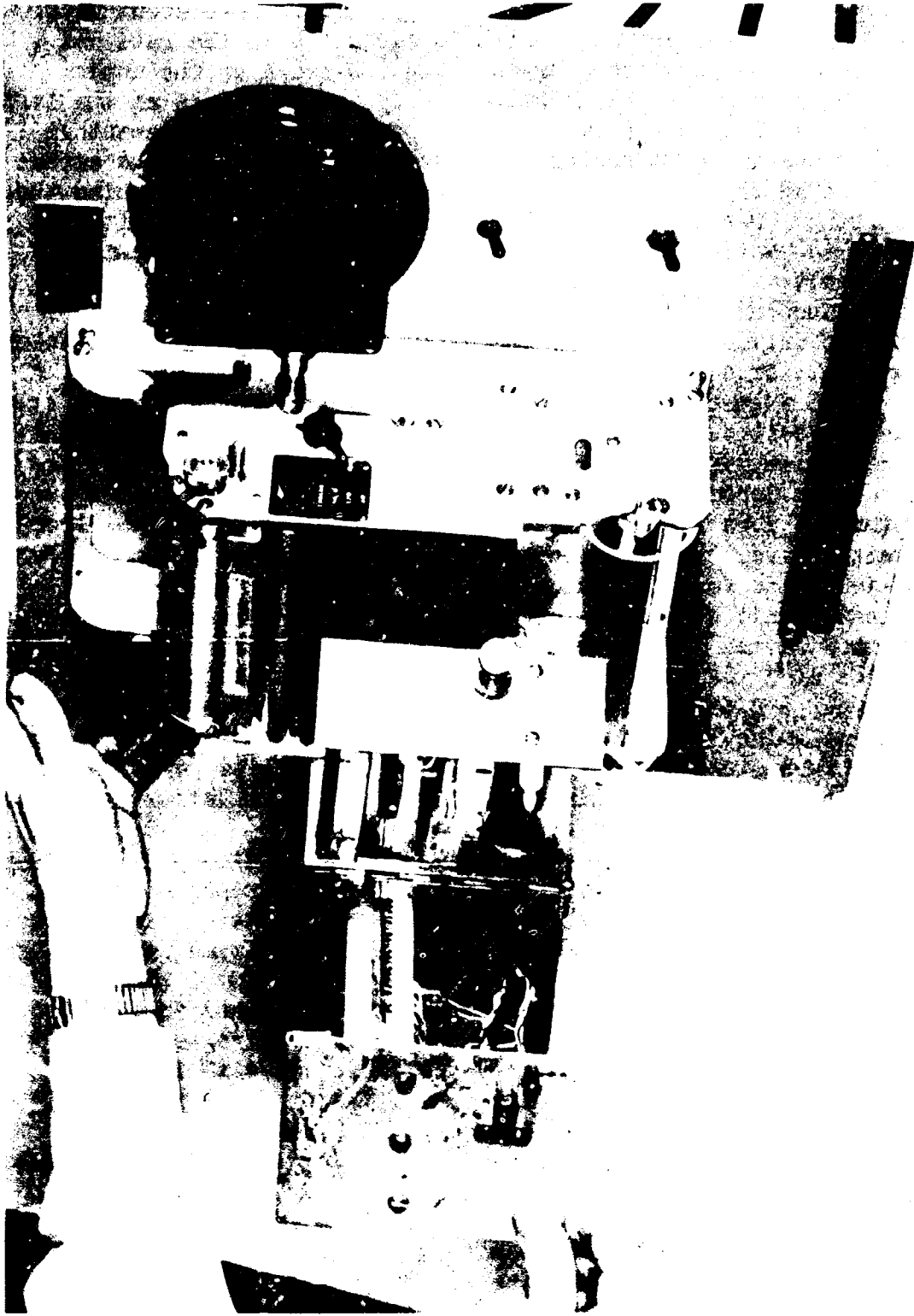

Figure 8.16 Tape recorder and patch panel.

The two to four traces which constitute the record at a station are chosen in the patch panel. These signals are amplified and shaped in the control unit. The amplifiers discriminate against noise. One of the signals is selected in the eight-level, eight-position bidirectional stepping switch. This signal performs two basic functions: (1) drives dose accumulator in the dose unit and (2) drives electronic circuitry in the rate unit. The amplifiers and shapers are plug-in units labeled A on the upper portion of the chassis; the bidirectional stepping switch is at the left of center. To avoid errors from loss of a portion of an increment in switching from one trace to another, all switching occurs at the actual instant of reading the higher pulse of the two traces between which the unit is shifting. Positioning of the bidirectional stepping switch is done in a semiautomatic controller with mutually exclusive upscale and downscale circuitry.

No scale smoothing is used to the dose unit, i.e., the 10-decade storage bank is driven directly by the channel chosen by the bidirectional stepping switch. Decade-scale smoothing is used for the rate unit. A minimum of 1 sec is required to print a new point on the curve and reset the computer circuitry. The pulses occur on the trace at a minimum of 10 sec of real time, which equals 0.1 sec computer time because of the 100-to-1 stepup. Consequently, at pulse spacings of less than 100 sec, a computation for dose rate is made on every tenth point. The bidirectional stepping switch directs the raw input into a channel containing an electronic decade device for scale smoothing.

The control unit also contains decimal side pen-marker pulse generators for both dose and dose rate. Each circuit contains a stepping relay, which operates at a low speed set by an RC delay circuit that may be changed with curve plotter time base rate in order to maintain pip spacing at a convenient value. The stepper returns to its home position at each scale change, then steps at an appropriate rate until its position matches that of the bidirectional stepping switch. Each of the latter steps generates a side-pen pip in the appropriate circuit.

The dose computer is the second panel from the bottom of the middle rack in Figure 8.15. As each pip on a raw data chart represents one increment of electrical charge through an ionization chamber and, hence, one increment of radiation dose, the total dose at any time is simply the weighted running total of pips on the various traces, totalizing from only one trace at a time. This totalizing is accomplished in the dose unit by a 10-decade adding-machine-type accumulator or register having inputs at the first, third, fifth, and seventh decade with internal carryover. When totalizing from the A trace, the input is fed to the first decade B trace to the third, C trace to the fifth, and D trace to the seventh. To provide three significant figure readout, a 3-decade follower relay bank looks through an interconnecting relay matrix and matches the three highest decades in the totalizer which contain data.

The follower relays switch a precision resistor matrix in such a manner that the resistance between the moving contact and one end of the matrix is proportional to the number of increments indicated by the follower relay bank. The curve plotter is an electronic recorder<sup>1</sup> connected to the precision resistor matrix as a resistance follower. Full

---

<sup>1</sup> Mfg by Minneapolis-Honeywell, Brown Division, Minneapolis, Minn.



scale on the 10-in.-wide chart is  $4 \times 10^n$ , where n ranges from 1 to 9 and the unit is the smallest increment of dose, 0.1 mr. The curve plotter covers 1 decade of dose. The scale and charts are calibrated 0 to 40, and only the central 80 percent of the scale is used. The interconnecting relay matrix advances the follower relays one step when the indicated dose is greater than 36.0. The curve plotter goes to a point equal to 3.61 (shift always occurs at the next increment above 36.0) and the side pen marker associated with the dose curve designates a new decimal multiplier. Because the integrated dose is always increasing, no downscale switching is required for the dose curve plotter.

The rate unit is the second panel from the top of the middle rack of Figure 8.15. The rate unit computes the dose rate by measuring the time between dose increments. Thus,

$$\text{Average dose rate over the time interval} = \frac{\text{Dose accumulated}}{\text{Time interval}}.$$

The dose accumulated equals the weighted value of the dose increment and is known from the position of the bidirectional stepping switch. Consequently, the dose rate is inversely proportional to time between increments. The system is designed to handle a range of 1 to 12 sec computer time, corresponding to a range of 100 to 1200 sec of actual time. The decade scaling on the control unit permits computation on actual time-pulse intervals ranging from 10 to 1200 sec. When decade scaling is used, the dose rate computed is the average dose rate for 10 dose increments.

Although the inverse time computation is an analog problem, it is performed by digital techniques. Consider a switch to be closed during a time interval that is to be measured. During this interval, constant-frequency pulses are fed through the switch into a binary counter chain. At the end of the interval, there rests in the counter chain a binary number that is proportional to the elapsed time. Now if each binary digit switches a conductance which is proportional to the weight of the digit into a constant-current shunt circuit, then the voltage appearing across the combined shunt network will be proportional to the inverse of the number of counts in the binary chain. Thus,

$$V_{\text{out}} = \frac{K}{\Delta t}, \text{ where } V \text{ is the output voltage, } \Delta t \text{ is the time interval and } K \text{ is a constant.}$$

The tape-reader drive is a synchronous motor. To prevent errors from power-line frequency changes, the constant-frequency pulses were derived from the power line. The basic frequency is tripled, and the binary chain counts 180-cps pulses. At the end of the timing interval, the 180 cps input is removed, and a bank of thyratrons are converted to the binary plates. If a count is in the binary, the thyatron is fired. The relays in the plate circuits of the thyratrons then switch in appropriate precision resistors. The curve plotter is connected to the output of the rate unit as a recording potentiometer.

The log-dose-rate computation is performed in a manner similar to the linear-dose-rate computation. The log-resistor network consists of a 31-section ladder attenuator shaped to the function,  $\log \frac{K}{\Delta t}$ .

Thus, the log curve is approximated by a series of straight lines that are correct at 31 points and less than 1 percent in error at other points. The log network furnishes the mantissa for the log curve. The characteristic, which is simply a fixed ordinate shift for each decade change, is obtained from a simple L-pad attenuator connected to the bidirectional stepping switch in the control unit.

The time unit provides the necessary time signals for control of the other parts of the computer. This unit is the top panel of the middle rack in Figure 8.15. The curve plotters cannot be energized at all times. The rate unit is reset to zero after every computation; if left energized, the curve plotters would also return to zero. If a pulse were fed into the dose unit while the plotter is still energized, the curve plotter would make violent excursions, due to the transient. Consequently, the pen motors for the curve plotters are normally blocked. After a computation is finished, the time unit introduces a 1-sec dead time into the rate unit. This is accomplished by counting 180 pulses of a 180-cps pulse train. At the close of the computation interval and the beginning of the 1-sec dead time, the rate unit readout is energized, and the recorder pen motors are unblocked. Since the recorder pens require 0.5 sec for full-scale deflection, 0.7 sec are allowed for the motors to operate. At the end of 0.7 sec (126 pulses) the recorder pen motors are blocked, and the thyatron readout is reset. At 0.9 sec (162 pulses), the binary chain is reset. At 1.0 sec (180 pulses), a new computation period is started.

The log time base unit provided a 3-decade logarithmic time base for a curve plotter. A stepwise approximation to a log time base was used. The times involved were 0.001 to 0.01 hr for the first decade, 0.01 to 0.1 hr for the second, and 0.1 to 1.0 hr for the third, actual computer times. The first decade corresponded to 0.009 hr, or 32.4 sec. To make the log time base power line synchronous, 97 steps of 3/sec were used. This actually corresponds to 32.33 sec rather than 32.4 sec. The second decade moved at 0.3 steps/sec and the third at 0.03 steps/sec. The stepping pulses were derived by dividing the power-line frequency by 20.

## 8.5 PERFORMANCE OF THE INSTRUMENTS

The gamma-field recording instruments operated for approximately 5 months. During any single operation, at least 70 percent of the instruments functioned properly. Both the fabrication and installation of the instruments were hurried. The quality of the workmanship on the instruments left much to be desired. Considerable time was taken to repair many of the instruments after their initial installation. A radiological calibration before and after the tests indicated that some detectors remained accurate to within  $\pm$  2 percent. Many had changed calibration because of gas leakage from the chambers.

The DRA was used for several months. Of the 140 tubes used, many of which were dual tubes, only two failed, both of these during the first 50 hr. Some difficulty was experienced with poor relay contacts. All relays were the high-reliability telephone type. The output relays in the precision relay matrices had fractional-volt potentials across the contacts. These low voltages were not sufficient to insure breakdown of the surface films on the contacts.

## 8.6 CONCLUSIONS

The tests proved the feasibility of monitoring gamma radiation over large areas. The instruments described above were satisfactory for the monitoring task. The magnitude of analyzing the collected data was too great for handling manually. The DRA was a satisfactory means of analyzing the data.

## Chapter 9

# RADIOLOGICAL SURVEYS AND FALLOUT PHOTOGRAPHY

R. C. Barry

Hong Lee

Extensive radiological information aboard the experimental ships was obtained during Operation Castle by survey teams using portable instruments. Some information about the visual characteristics of the fallout was obtained through photographs made with a 16-mm movie camera.

Beta, gamma-field, and directional-gamma measurements and wipe samples were taken. Data sheets issued to the survey teams designated the type and location of all measurements. Readings were taken in a prescribed manner at premarked locations above and below decks. This procedure minimized the radiological exposures of the relatively untrained personnel and misinterpretations of the data. Survey data were individually checked, corrected, transferred to multiple forms, and were ready for distribution within 4 hr.

Beta and directional-gamma measurements made before and after decontamination provided the basis for determining the effectiveness of specific decontamination operations. Gamma-field measurements furnished information on the reduction of the radiation field.

Fallout photography was accomplished with a shielded 16-mm movie camera, which snapped a photograph every 30 sec. The target space was the focal region of an intense reflected electronic flash light beam.

The fallout photography showed that there was no gross fallout on the YAG 40 during the operating time of the camera for all the shots in which the ship participated. A few particles less than 100  $\mu$  in diameter were photographed in Shots 1 and 5.

### 9.1 OBJECTIVE

The principal objective of the radiological surveys was to obtain radiation data throughout the test ships to augment that from the fixed gamma-detection stations. Fallout photography was attempted to determine its feasibility for obtaining information on fallout characteristics and correlation between the time intervals for visual fallout and detection of radiation aboard ship.

The radiological surveys required measurements of the following types:

1. Gamma radiation: (a) field intensities 3 ft above deck (height for measurement of whole-body radiation) in weather-deck areas; (b) field intensities at specified locations in the interior spaces; and (c) radiation intensities from limited contaminated surface areas within an extended radiation field.

2. Beta radiation: (a) beta intensities on specific weather deck surface areas, and (b) beta intensities of surfaces in the interior spaces.

3. Wipe samples.

Items 1c and 2a were needed to determine the effectiveness of decontamination methods upon a specific surface area within a radiation field. They were also needed to define localized hot spots.

Items 2b and 3 provided the only means of determining the relative distribution of contamination within the interior spaces of the ship. Item 3 was also used after decontamination operations to determine the amount of activity removable by wiping.

## 9.2 INSTRUMENTATION

Wipe samples were counted with a rate meter or a suitable scaler. The number and types of instruments employed for the other measurements of the radiological surveys were: 25 AN/PDR-T1B radiacs (ion chamber); 12 AN/PDR-18A (scintillation); 25 AN/PDR-27C (geiger tube); 12 NRDL RBI-12 beta probes (bucking ion chambers); and 2 NRDL RGG-1 directional-gamma probes (shielded geiger tube).

The first three types are standard radiac instruments and were selected for general use. Since the AN/PDR-T1B was the only one of the three which had the optimum range of sensitivities, required practically no maintenance and had a long battery life, it was the only standard hand radiac instrument used for survey work. The instrument was furnished with a unipod (small aluminum tube 3 ft long) so that all readings were taken at the same height above the deck. All T1B's were checked and calibrated on a cobalt range before each shot.

The NRDL RBI-12 beta probe is a development model whose prototypes were built for past field operations. It is a small, light-weight hand instrument that measures beta radiation from an area 10 by 10 cm when placed 1 cm above the surface. Readings are in microamperes (0 to 20) with four ranges from X1 to X1000 calibrated from 20 to 20,000 microcuries of  $\text{Sr}^{90}$ - $\text{Y}^{90}$ . Instruments were calibrated before each day's monitoring operations.

The NRDL RGG-1 directional-gamma probe is a developmental instrument and resulted from a limited effort to supplement the beta probe. The RGG-1 was developed from readily available material as a semiportable instrument. Weight and size were held within limits, so that it could be hoisted aboard ship manually and used to take measurements on easily accessible weather deck areas.

The instrument consisted of a lead-shielded geiger tube mounted at a height of 3 ft on a tubular steel stand, which also supported the electrometer case and calibration button. When directed downward, only gamma rays from a circular area 3 ft in diameter are detected, except for about 1 percent leakage through the lead shield for the range of energies encountered.

Readings were taken directly in arbitrary units, which were later converted to milliroentgen per hour. The useful range of measurements

was approximately from 10 mr/hr to 10 r/hr in four ranges.

The instruments were calibrated on a Co<sup>60</sup> range and were checked and adjusted to a portable gamma standard every few minutes during operation.

A more-detailed description of the instruments, details of their calibration and maintenance, and an operational evaluation---together with recommendations---may be found in Appendix G.

9.2.1 Equipment for Fallout Photography. A Bell and Howell, Model 200 Autoload 16-mm movie camera, equipped with a 3-in. lens focused at 4 ft, and a f5.6 relative aperture was used. It was modified to operate on single frame when tripped by an electric-motor-driven cam. The shutter mechanism was synchronized for zero-delay flash. A right-angle prism directed the light rays into the lead shield holding the camera. A special microfilm emulsion film (Eastman Kodak Special Order 918) was used. This film could be exposed to about 1000 r gamma radiation without serious fogging (see Appendix G).

The optical sampling station was situated on the starboard side of the deck house over No. 3 hold on the YAG 40. The camera was located in a 4-in. lead shield inside the deck house, together with electrical timing equipment. The lighting unit was located on a pedestal about 2 ft above the deck and 3 ft from the deck-house bulkhead. A time clock inside the deck house energized and de-energized the electrical system when the station started and stopped operation.

The exterior lighting system was mounted on a metal frame and consisted of an electronic flash unit (Heiland Strobonar III), housed in a wooden box, and an elliptical mirror. The light from the flash lamp was collected by the mirror and focused about midway between the lamp and mirror. The lamp was flashed once for each individual picture. An open black box served as a nonreflecting background. The volume within which particles were lighted and photographed was 6 in. wide, 4 in. high, and 10 in. deep; however, the depth of field of the lens was only 3 in. A schematic diagram of the entire system is shown in Figure 9.1.

### 9.3 OPERATIONS

Besides the two NRDL men assigned to the radiological survey phase of Project 6.4, 90 Navy enlisted men were used. Six of these 90 were permanently assigned and acted as group leaders. A training schedule for these group leaders was maintained throughout the operation. With few exceptions, all the Navy enlisted men were inexperienced in the task to which they were assigned. Consequently they had to be instructed to read and operate the survey instruments and also had to be indoctrinated in the radiological safety precautions. The transient survey personnel were usually available for training  $\frac{1}{2}$  day before each operation. Obviously the training was brief and all instructions had to be clear and concise in order that the required survey could be made satisfactorily within the dosage limitations set for the men.

All surveys were made by teams consisting of either one instrument man and one recorder or two instrument men and one recorder. Separate

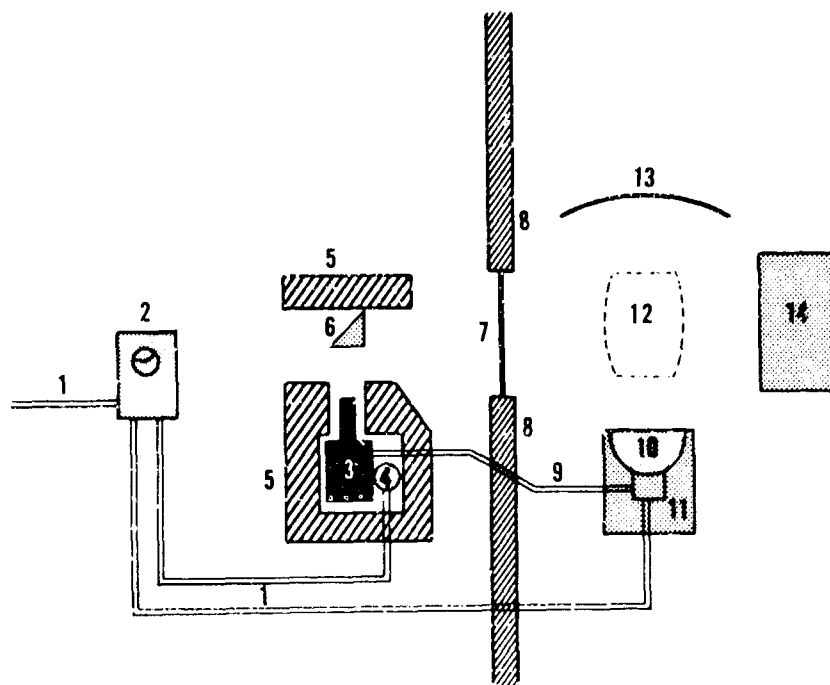

1. 110-v AC circuit
2. Pre-set on-off timer switch
3. 16-mm camera
4. Motor and speed reducer unit (2 rpm)
5. Lead shield camera housing
6. 90° prism
7. Plate glass port hole
8. Bulkhead
9. Electronic flash trip wire
10. Electronic flash unit
11. Electronic flash housing
12. Target volume
13. Reflector
14. Target background

Figure 9.1 Fallout photography station.

teams were assigned to do beta, gamma, directional-gamma, and wipe sampling aboard ship. Each recorder was issued data cards on which had been inserted the station locations that his team was to survey. All survey points were marked on decks and bulkheads as follows: The mark indicated the location, the number identified it, and the arrow showed how the instrument was to be oriented with respect to the monitor. In most cases the arrow pointed forward, and the monitor's body shielded the instrument from behind. Dosage limitations prevented multidirectional readings being taken.

Locations of the 855 to 955 survey points aboard the ships are shown in Figures G.8 through G.10, Appendix G.

**9.3.1 Radiological Surveys.** A total of 13,276 readings were recorded in the shipboard radiological surveys. All surveys were checked, corrected for instrument variations, and logged into multiple form data books. They were then made available to all problem leaders requiring them. When the need was urgent, the data were available in final form within 4 hr---in any event within 24 hr.

The following items indicate the extent of the radiological surveys in Project 6.4.

1. Complete initial radiological surveys were made on the YAG 39 and YAG 40 upon their arrival in the lagoon after Shots 1, 2, 4, and 5. Each initial survey included the following:

beta surveys

YAG 39, 355 exterior readings and 64 interior readings

gamma surveys

YAG 39, 243 exterior readings and 104 interior readings

directional gamma surveys

YAG 39, 40 readings

wipe samples

YAG 39, 69 readings

YAG 40, same as YAG 39 except for 100 additional interior beta readings

2. Decontamination surveys were conducted before, during, and after each separate stage of all the decontamination operations.

3. Final surveys were conducted at the completion of all decontamination operations. These included all the exterior station measurements taken in the initial survey.

4. Survey support was given the aircraft decontamination project during all their operations that were conducted on Site Fred.

5. Survey support was given the ship decontamination project for their concrete studies conducted on Site Fred.

6. Instrument support was given Project 6.5.

9.3.2 Fallout Photography. The photography station which was controlled by pre-set timing switches was operated as follows:

Shot 1	H to H + 4
Shot 2	H to H + 4
Shot 4	H + 1 5/6 to H + 5 5/6
Shot 5	H + 1/3 to H + 1/3

Pictures were taken every 30 sec during these periods. About 450 to 500 individual frames were exposed per shot.

Recovery was accomplished 3 to 7 days after shot day, depending on availability of the ship and personnel dosage.

All films were processed in D-76 developer to a gamma (contrast) of 1.0. The processed films were examined first with a 15X binocular microscope and then with a 150X microscope. The lower power unit was



used to find the gross indications of particles in the hundreds of frames examined; the higher magnification was used for detailed study of individual frames. Particle sizes were estimated by comparison with photographs of a wire size.

#### 9.4 RESULTS AND DISCUSSION

Much of the radiological survey data was obtained to meet specific needs of problem leaders who have presented it in their particular chapters of this report. The data discussed in this section pertain primarily to the operational phases of the survey.

9.4.1 Summary of Instrument Evaluation. A detailed operational evaluation of the instruments is given in Appendix G. A brief summary of this evaluation follows:

AN/PDR-T1B: Excellent instruments; perfectly suited for gamma measurements.

AN/PDR-18A: Not used, range of sensitivities were not suitable for present work.

AN/PDR-27C: Poor operating life in climatic conditions existing at the proving ground.

NRDL RBI-12:

Operational life of batteries, very good

Range of detection, excellent

Time constant, slow on X1 scale, very good on others

Zero set, satisfactory

Switches, some were faulty

Calibration drift, about 6 percent per month

Linearity, excellent

Gamma sensitivity, negligible

Durability of construction, poor

NRDL RGG-1: In general, the directional gamma probe was not satisfactory. Its weight and bulk made it difficult to transport about aboard ship. Its operation was slow, requiring three readings in order to record a single measurement. The instrument was dependent upon voltage and had to be recalibrated for each measurement. Constant handling of the cobalt standard ultimately led to the contamination of the source holder (end of plug) which rendered subsequent measurements uncertain. The instrument was nonlinear, and correction curves were required to determine actual radiation levels.

9.4.2 Comparison of Decontamination Factors Derived from Beta and Gamma Measurements. Gamma field intensities measured 3 ft above the deck were used as the measure of the principal radiation hazard to personnel in the tactical situation. Reduction of intensity so measured can be considered a measure of the effectiveness of a decontamination effort.

In these tests, limitations of time, dosage, and manpower precluded decontamination of all shipboard surfaces and equipment. Also, it was not always possible to decontaminate all designated surfaces in one day. Since it was desired to compare the effectiveness of various decontamina-

tion procedures to determine those giving optimum performance, various decontamination procedures were applied to separate specific test areas. The gamma measurements 3 ft above the deck gave an adequate picture of the radiological situation but included background radiation from surfaces not within the scope of the decontamination tests. To obtain data for test purposes, it was necessary to make measurements of radiation intensities from limited contaminated surface areas within an extended radiation field. The directional gamma probe and the beta probe were used for this purpose.

The use of the beta probe assumes that a constant beta-to-gamma ratio exists throughout the time period of interest. Probable sources of error in this assumption are: different decay curves for beta and gamma, selective removal of isotopes during decontamination, and absorption (particularly on porous surfaces)---which would attenuate the beta intensity at the surface to a greater extent than the gamma intensity from the contamination absorbed. While the magnitude of these possible

TABLE 9.1 DECONTAMINATION FACTORS AND RATIOS OF BETA-GAMMA DECONTAMINATION

Measurements <sup>(a)</sup>	High Background Case 1 <sup>(b)</sup>			Low Background Case 2 <sup>(c)</sup>		
				1st Decon	2nd Decon	3rd Decon
$\beta$	22.4		22.4	1.12	1.66	1.38
$D_{\gamma}$		20	20			
$\gamma_3$	9.5	9.5				
$\gamma_s$				1.14	1.36	1.21
r	2.35	2.11	1.12	0.98	1.22	1.14

(a) Measurement symbols;  $\beta$ , surface beta  
 $D_{\gamma}$ , directional gamma, 3 ft above surface  
 $\gamma_3$ , total gamma, 3 ft above surface  
 $\gamma_s$ , surface gamma (TLB)  
 r, ratio of  $\beta$  decontamination factor to the corresponding gamma decontamination factor in the table.

(b) Case 1, 28 deck stations over length of ship, before and after 6 days of decontamination.

(c) Case 2, 24 concrete slabs, decontamination ashore in low background.

errors is unknown, experience has indicated that beta measurements are useful where a directional gamma measurement is needed.

The material in Table 9.1 was extracted from the extensive survey data. It presents decontamination factors and the ratio of beta-to-gamma decontamination factors for two extremes of background conditions. The decontamination factors are the reading before divided by the reading after decontamination.

In Case 1, since there were extensive radiation sources from undecontaminated surfaces and equipment, corresponding discrepancies appear in the decontamination factors calculated from total gamma-field (radiation from all sources) and surface (directional-gamma and beta) measurements. There is relatively good agreement between the two types of surface measurements.

Only limited data from the directional-gamma probe can be presented, due to operational difficulties; however, a further comparison (Case 2) can be made between decontamination factors calculated from beta and

CONFIDENTIAL

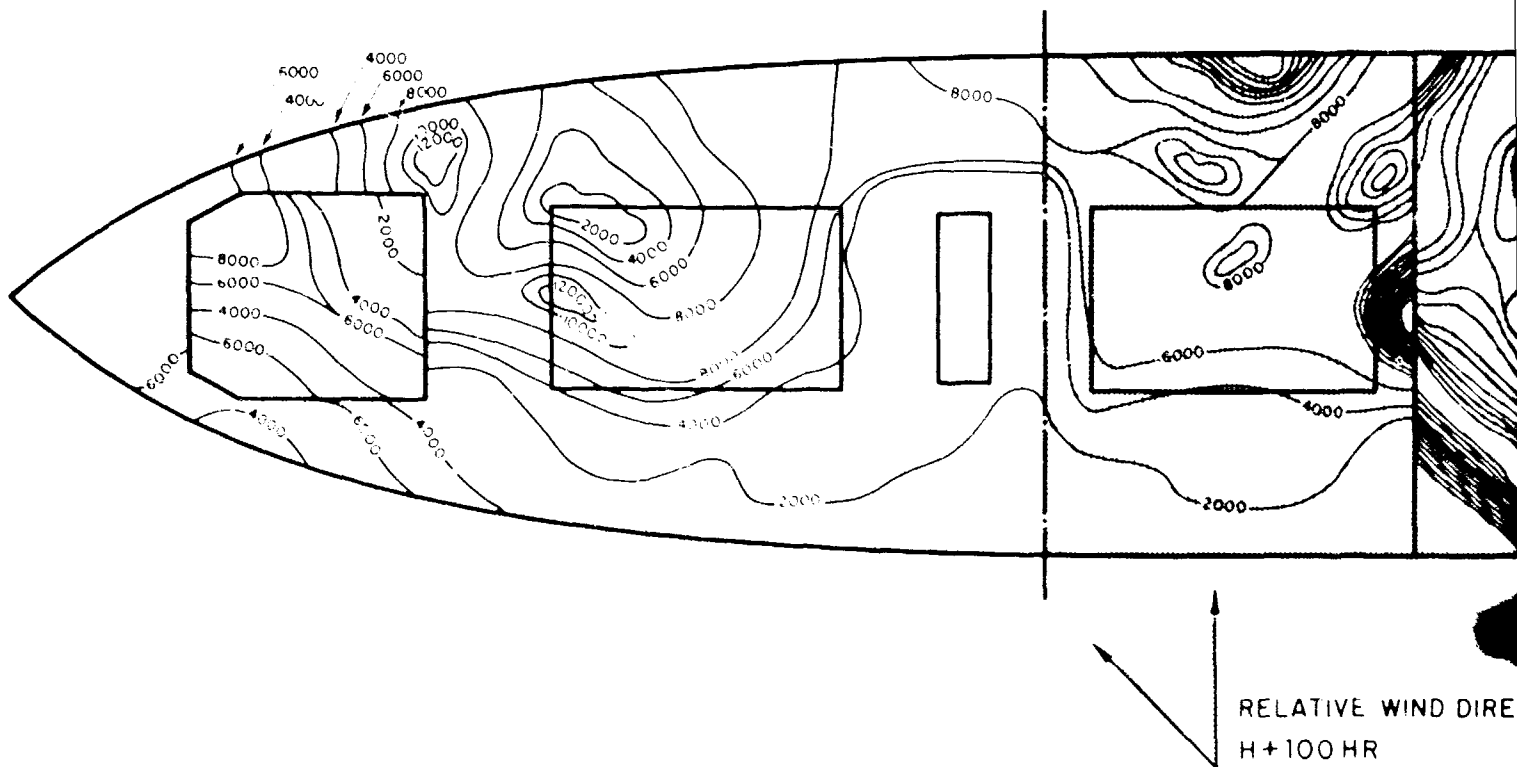
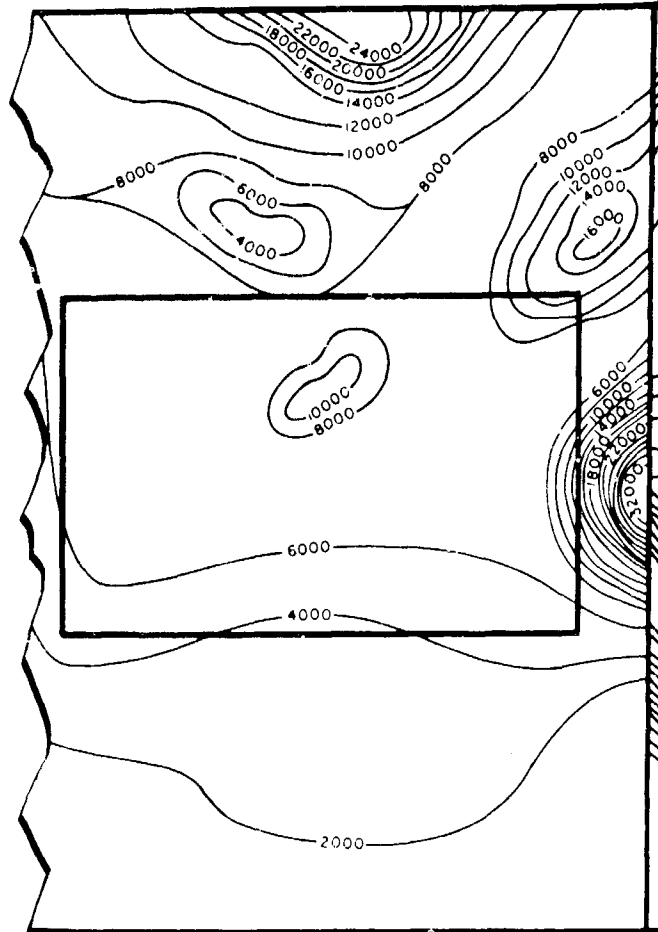
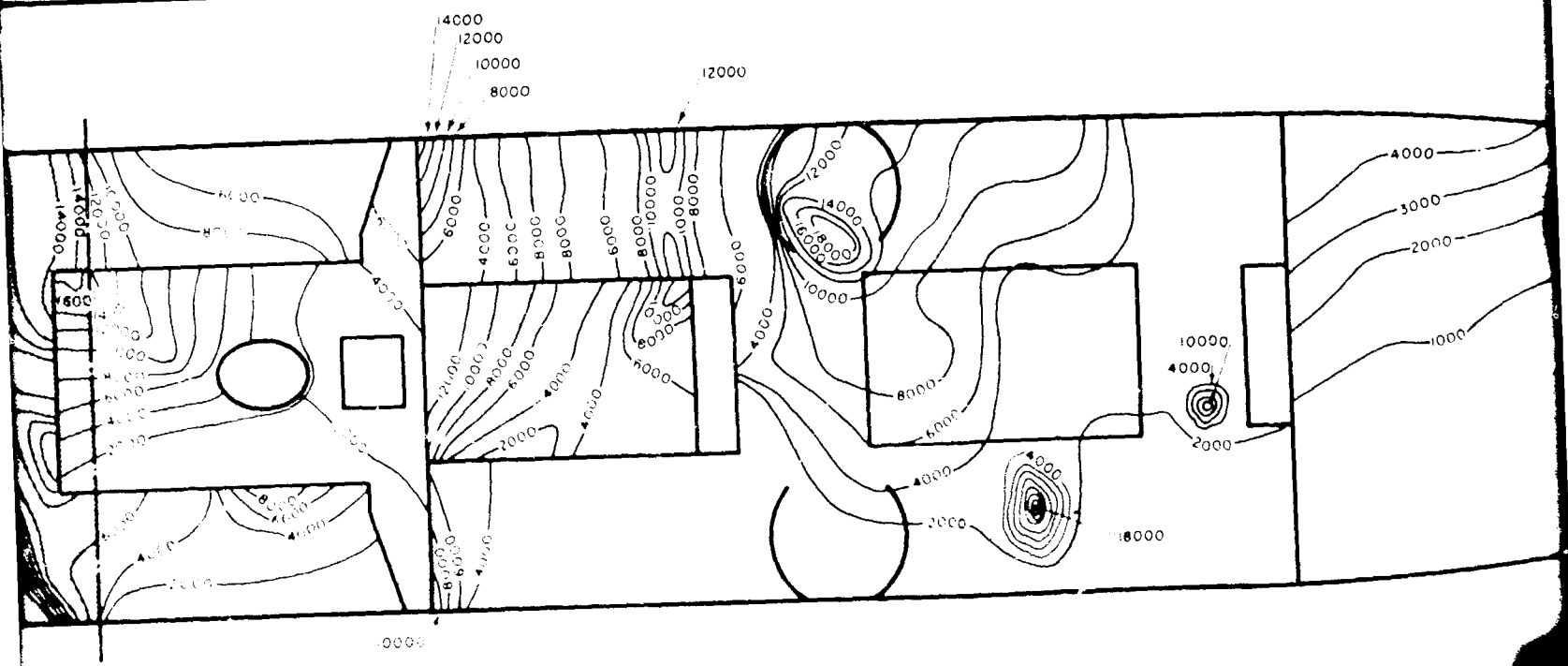
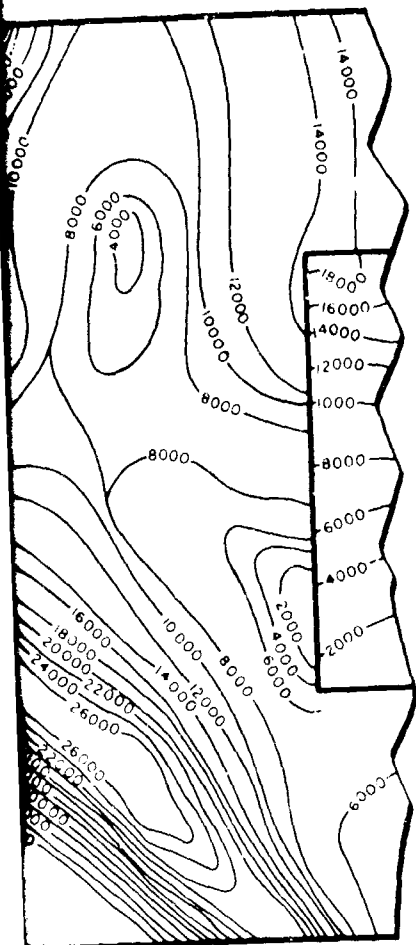

Figure 9.2 Radiation contours

CONFIDENTIAL

CONFIDENTIAL



VALUES IN MICRO-AMPS

$1 \mu a \approx 1 \mu c$  ( $^{90}\text{Sr}$  POINT SOURCE STANDARD)

original data survey on the YAG 40 after Shot 2. 31 March 1954.

CONFIDENTIAL

CONFIDENTIAL

2

CONFIDENTIAL

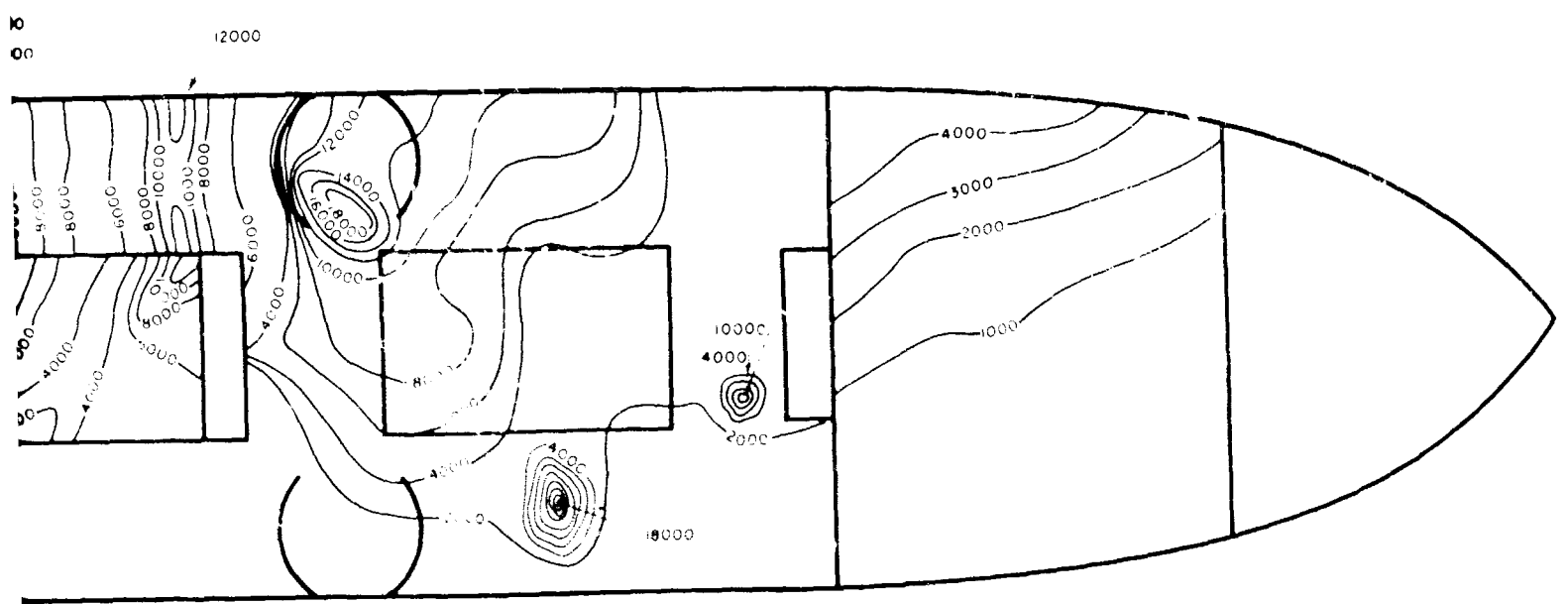

N MICRO-AMPS  
(JOINT SOURCE STANDARD)

G 40 after Shot 2. 31 March 1954.

CONFIDENTIAL

3

CONFIDENTIAL

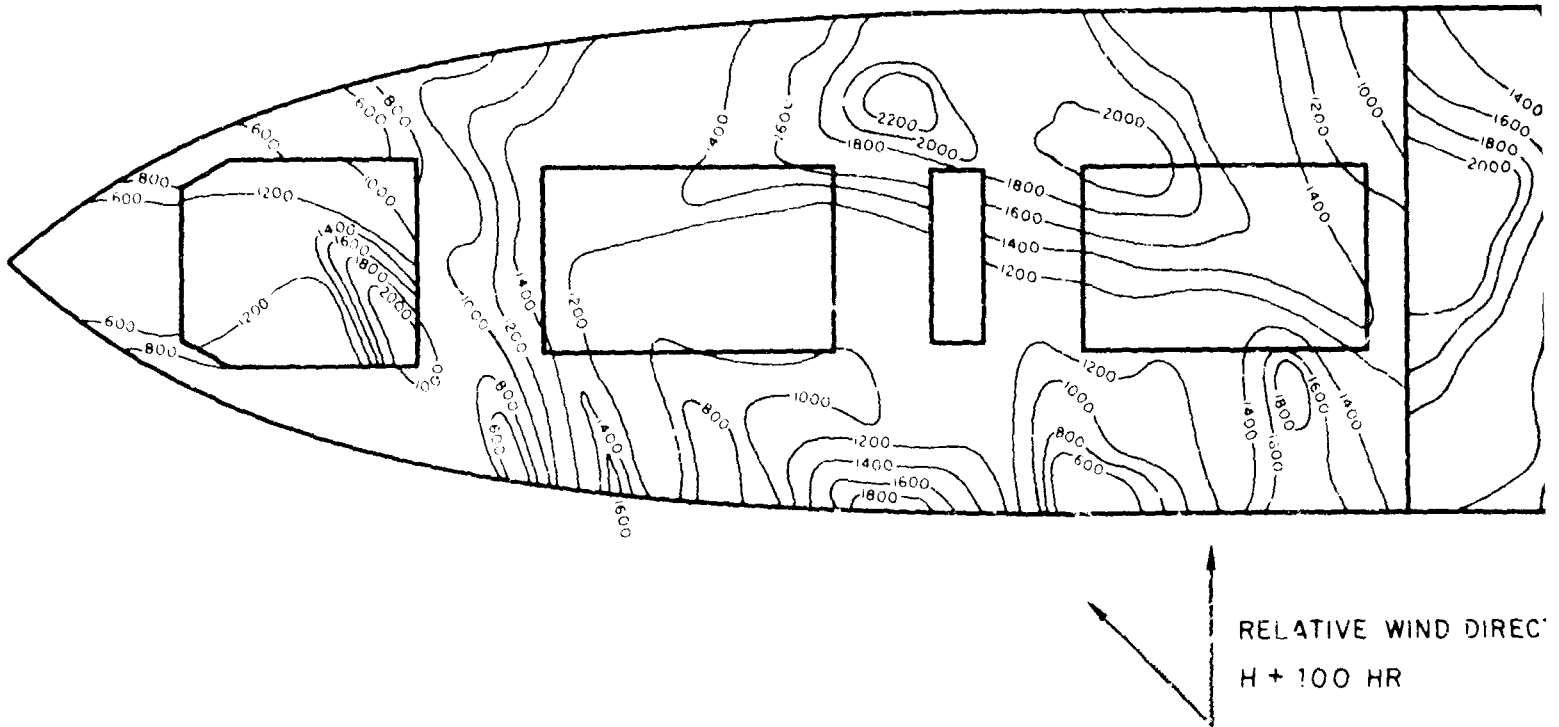
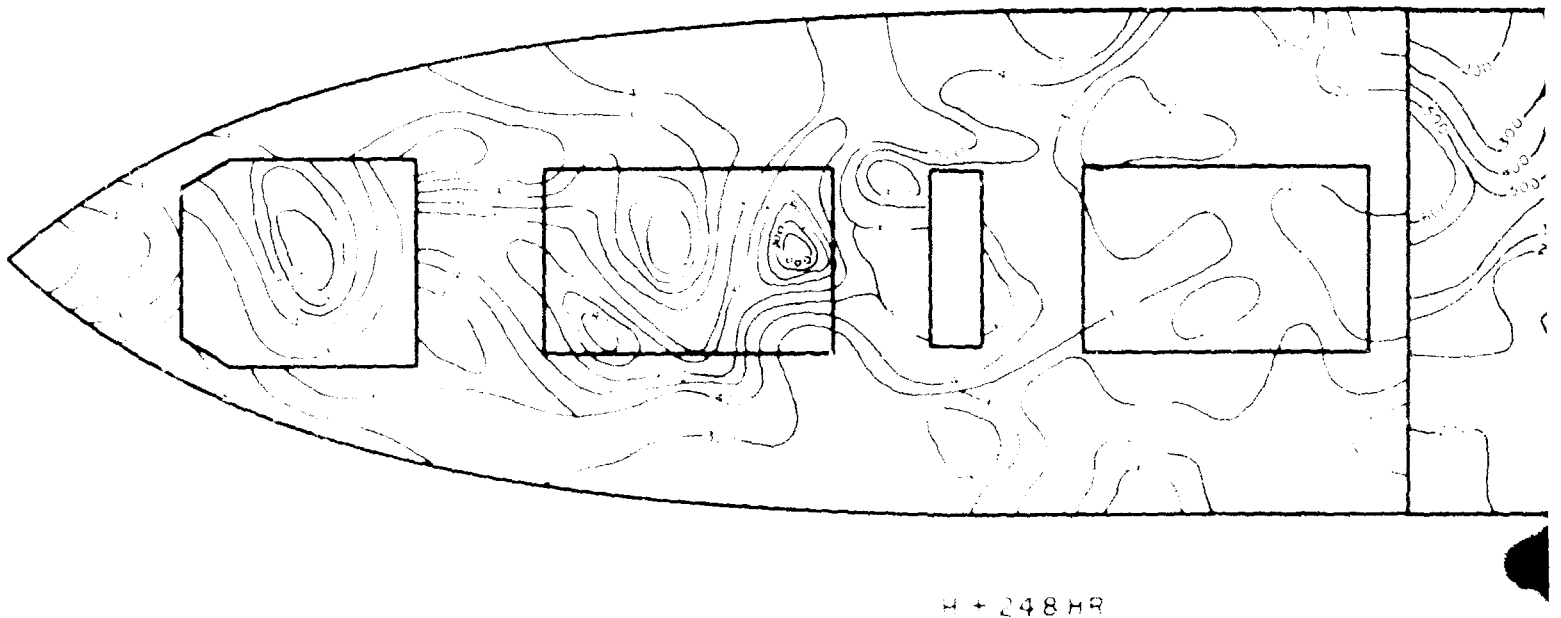

Figure 9.3 Radiation contours from



H + 248 HR

1400

Figure 9.4 Radiation contours from d

CONFIDENTIAL

# CONFIDENTIAL

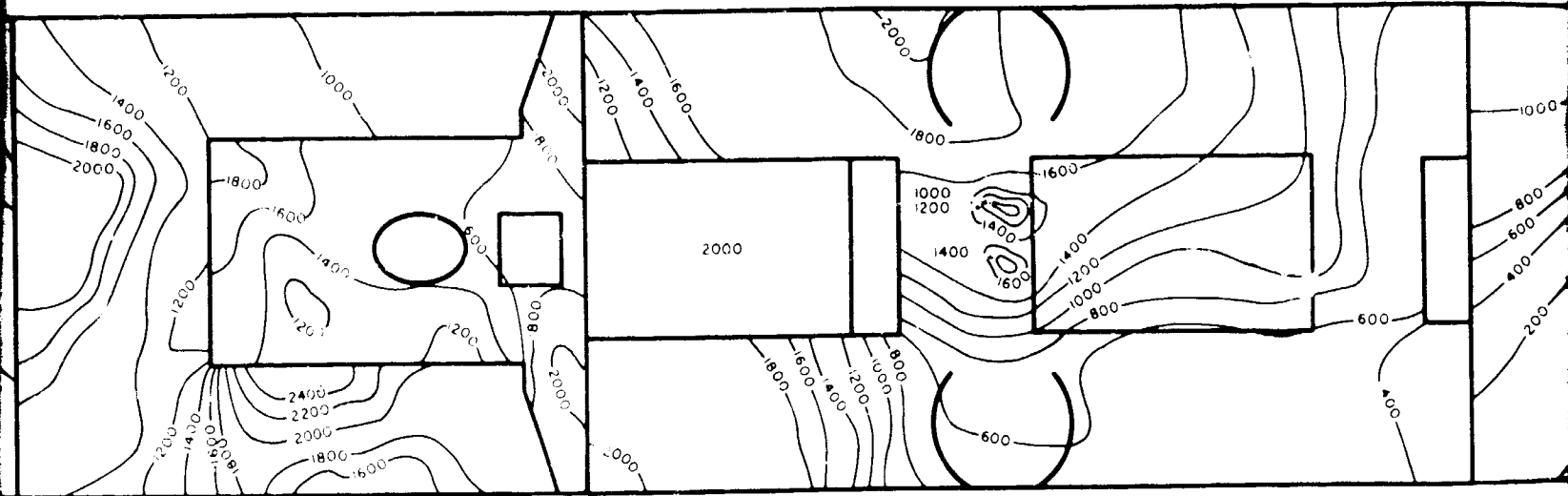

WIND DIRECTION

VALUES IN MR/HR

Contours from original gamma survey on the YAG 40 after Shot 2. 31 March 1954.

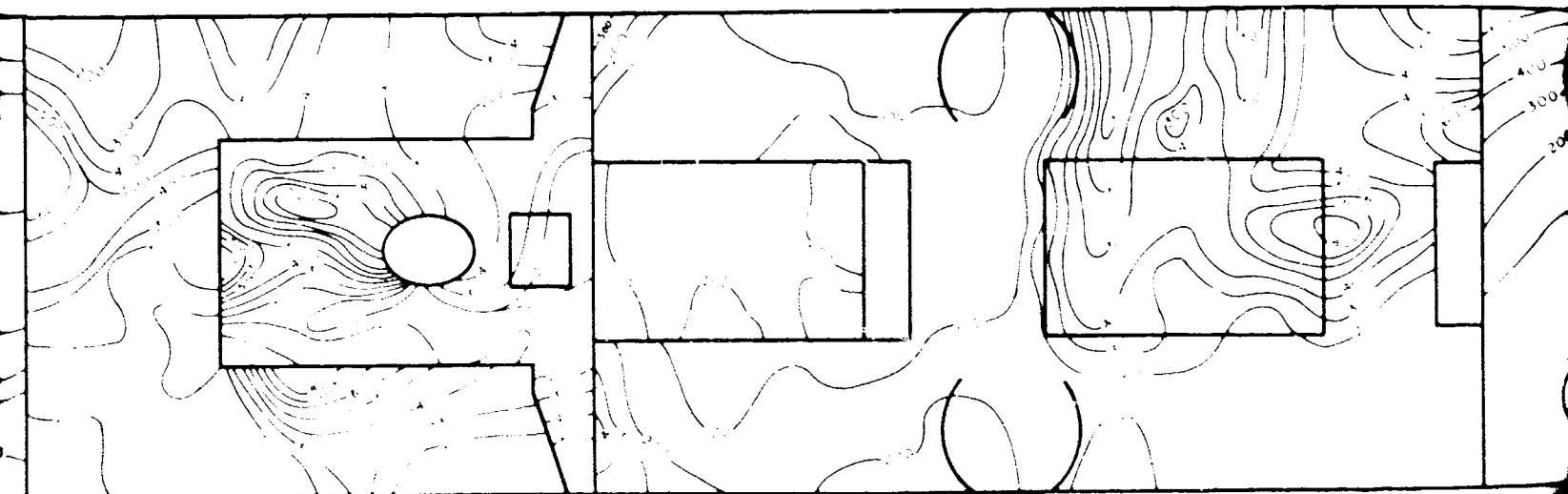

VALUES IN MICRO-AMPS

$1 \mu a = 1 \mu c$  ( $Sr^{90}$  POINT SOURCE STANDARD)

Contours from decontamination beta survey on the YAG 40 after Shot 2. 6 April 1954.

CONFIDENTIAL

# CONFIDENTIAL

2

# CONFIDENTIAL

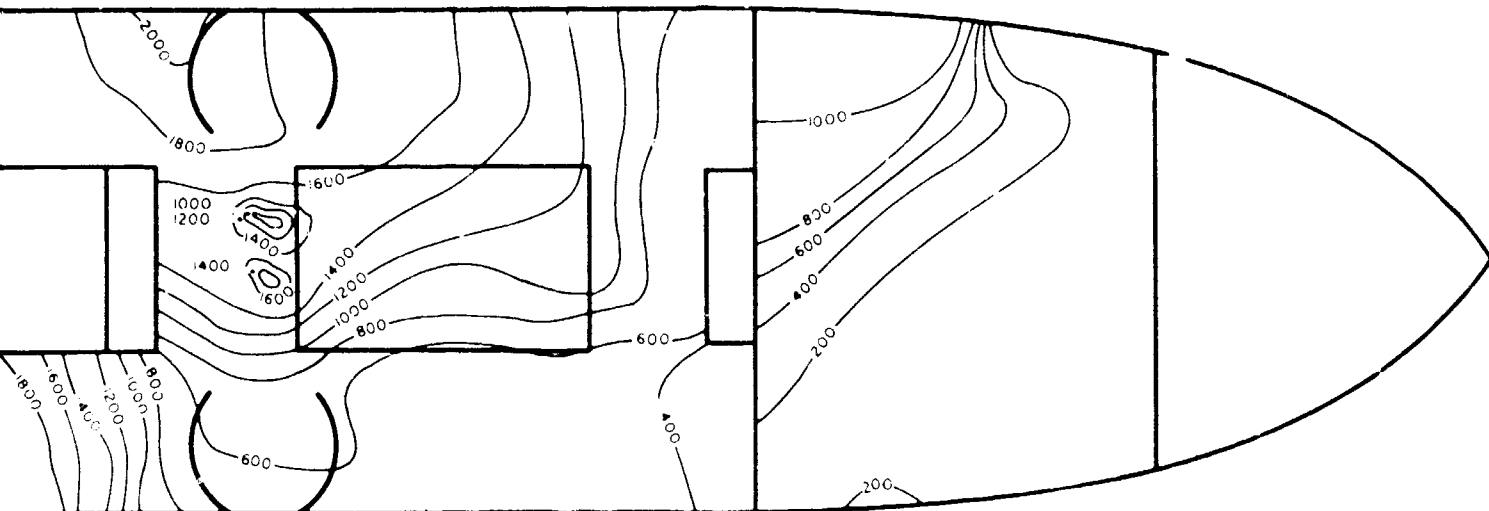

VALUES IN MR/HR

after Shot 2. 31 March 1954.

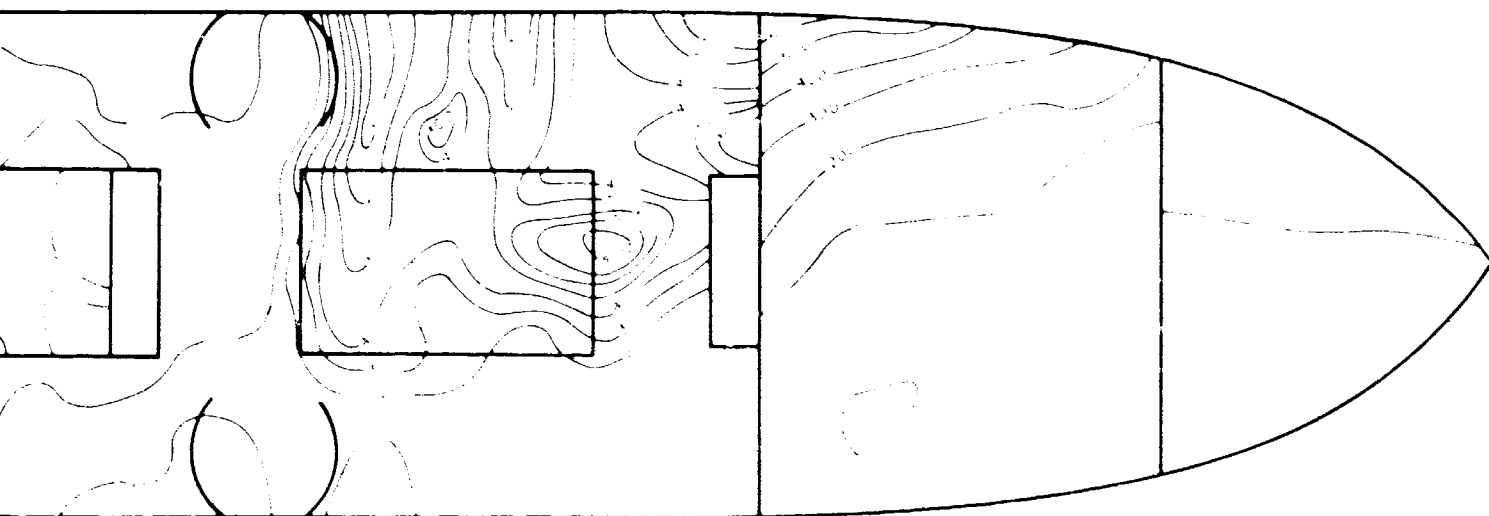

RD 1  
40 after Shot 2. 6 April 1954.

# CONFIDENTIAL



CONFIDENTIAL

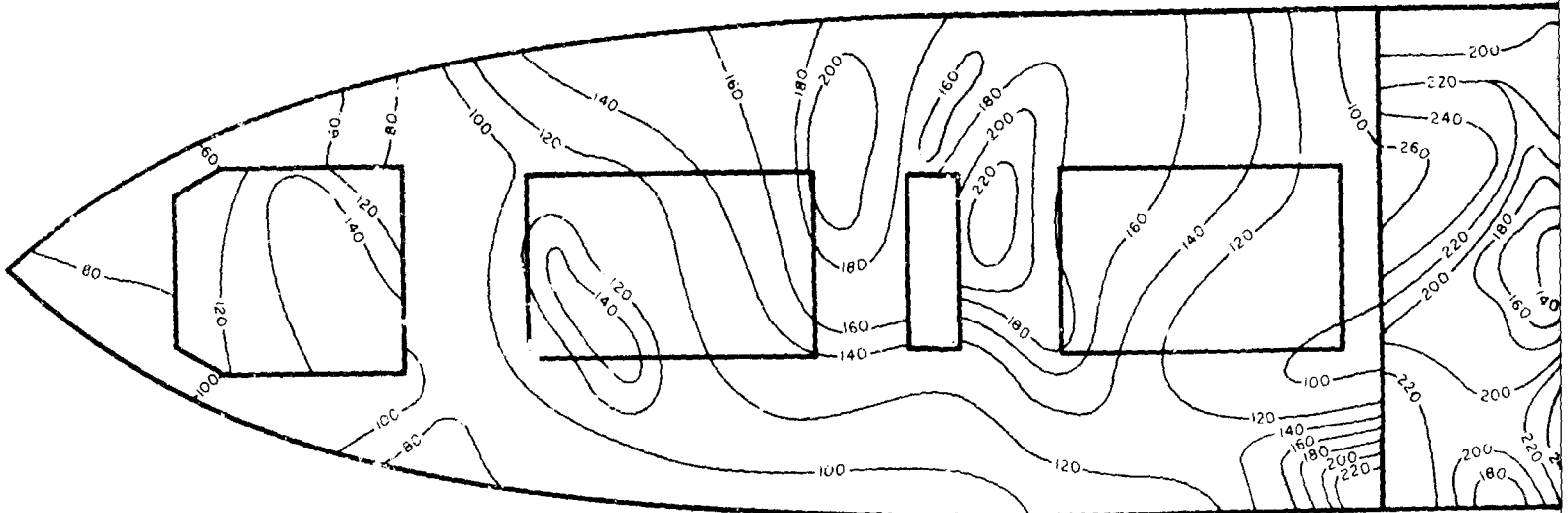

H + 248 HR

Figure 9.5 Radiation contours from dec

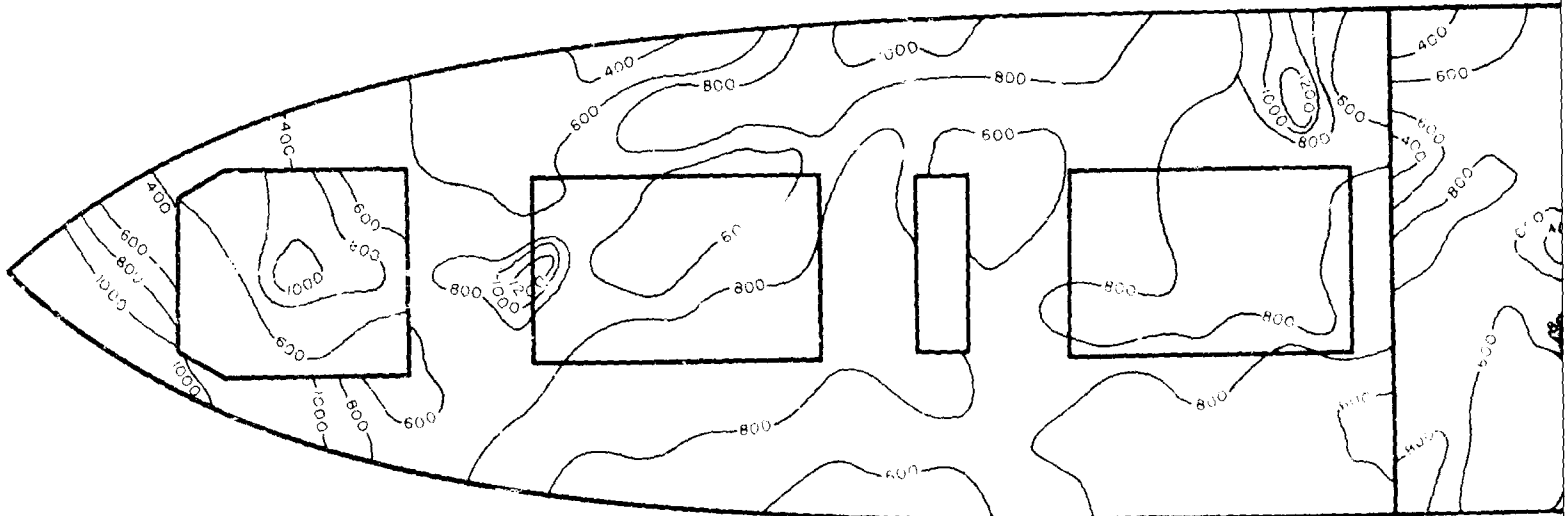

RELATIVE WIND DIRECTION  
H + 80 HR

Figure 9.6 Radiation contours from

CONFIDENTIAL

# CONFIDENTIAL

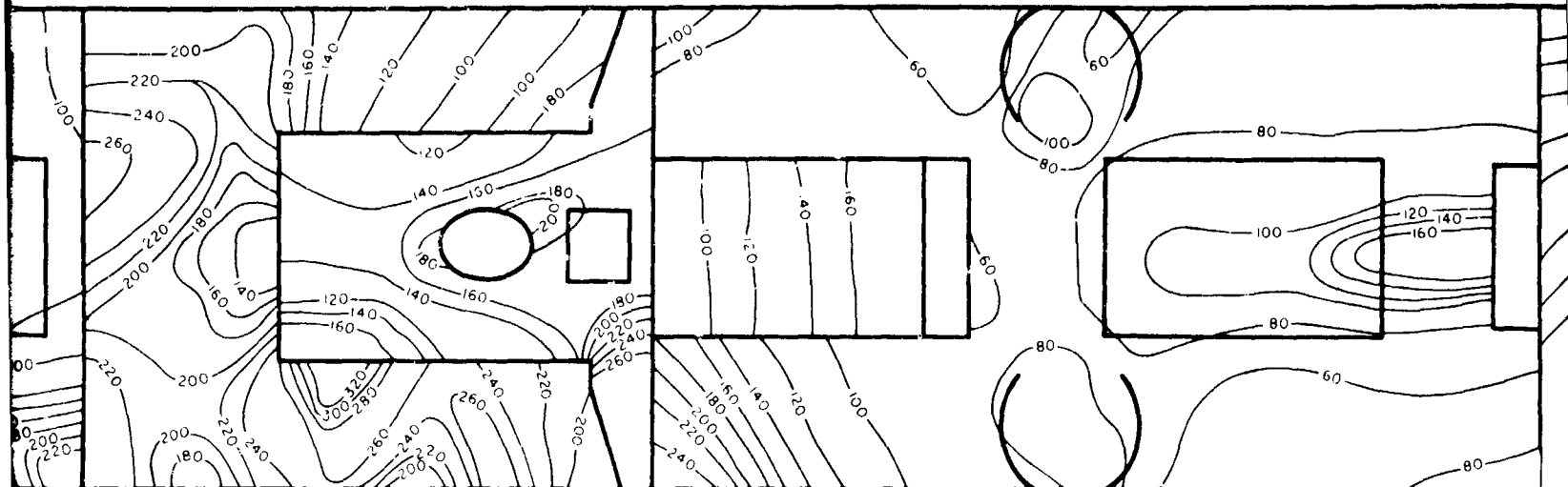

VALUES IN MR/HR

Contours from decontamination gamma survey on the YAG 40 after Sht 2. 6 April 1954.

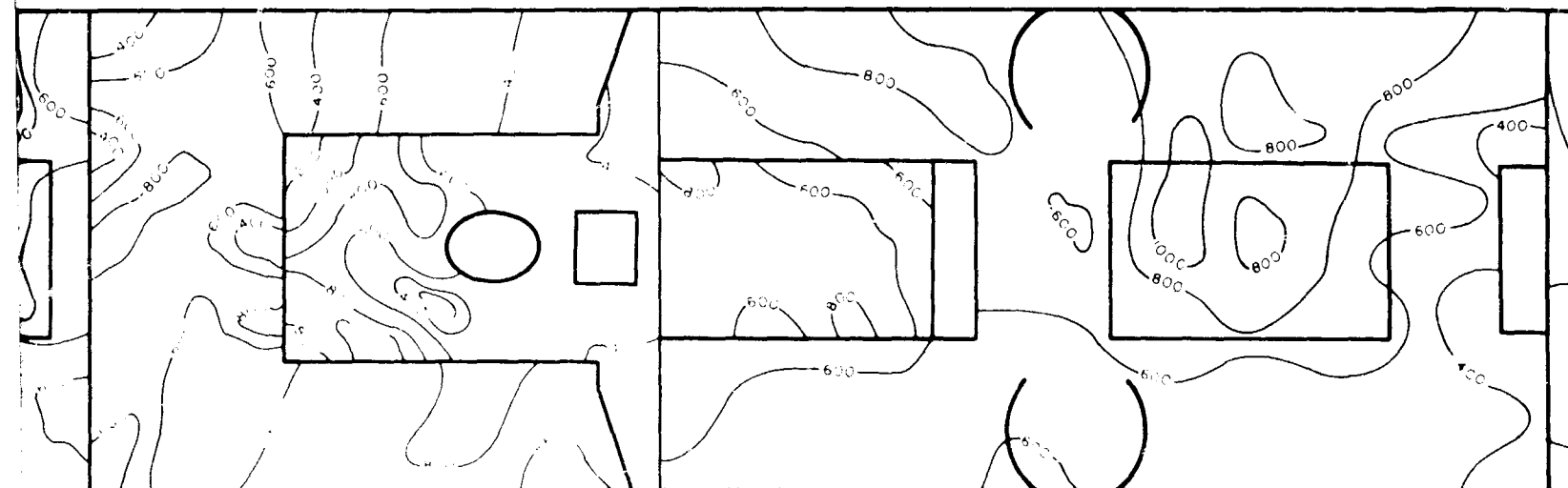

WIND DIRECTION  
0 HR

VALUES IN MICRO-AMPS

$1 \mu a \approx 1 \mu c$  ( $Sr^{90}$  POINT SOURCE STANDARD)

Contours from original beta survey on the YAG 40 after Shot 4. 29 April 1954.

CONFIDENTIAL

# CONFIDENTIAL

CONFIDENTIAL

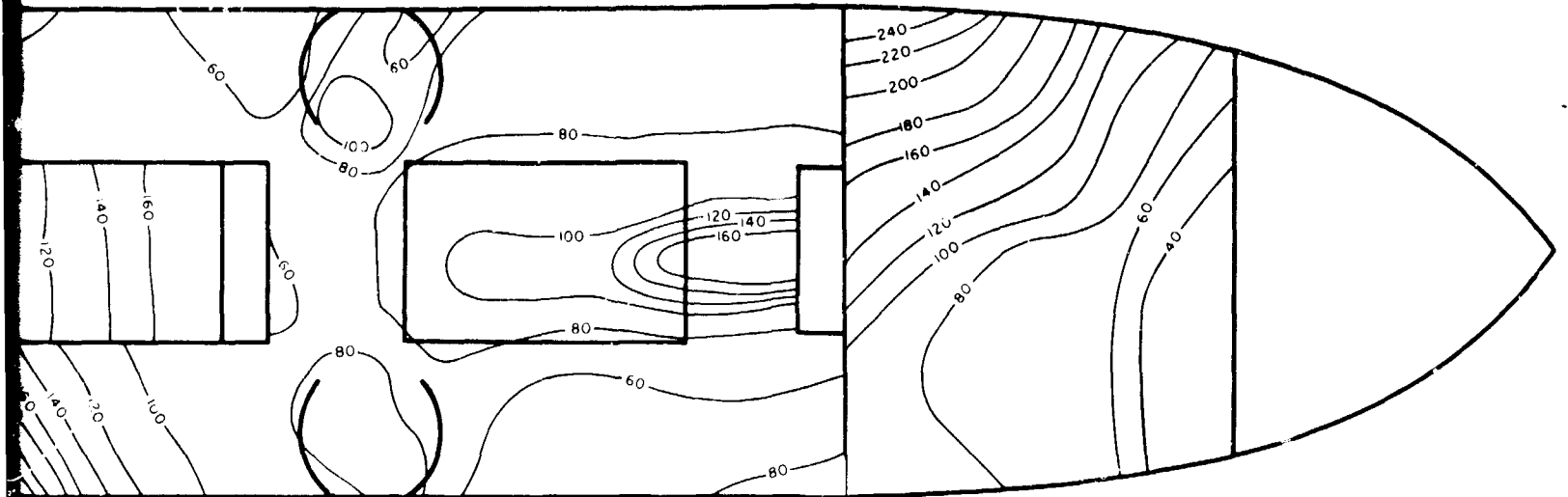

the YAG 40 after Shot 2. 6 April 1954.

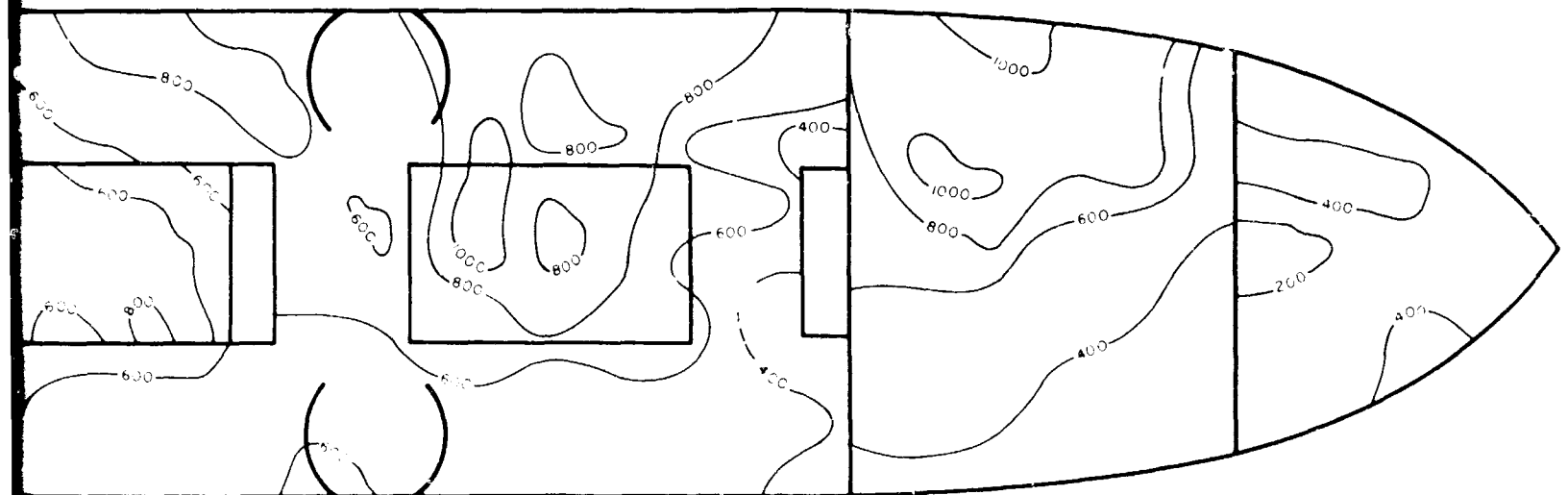

VALUES IN MICRO-AMPS

$1 \mu a \approx 1 \mu c$  ( $Sr^{90}$  POINT SOURCE STANDARD)

YAG 40 after Shot 4. 29 April 1954.

CONFIDENTIAL

3

CONFIDENTIAL

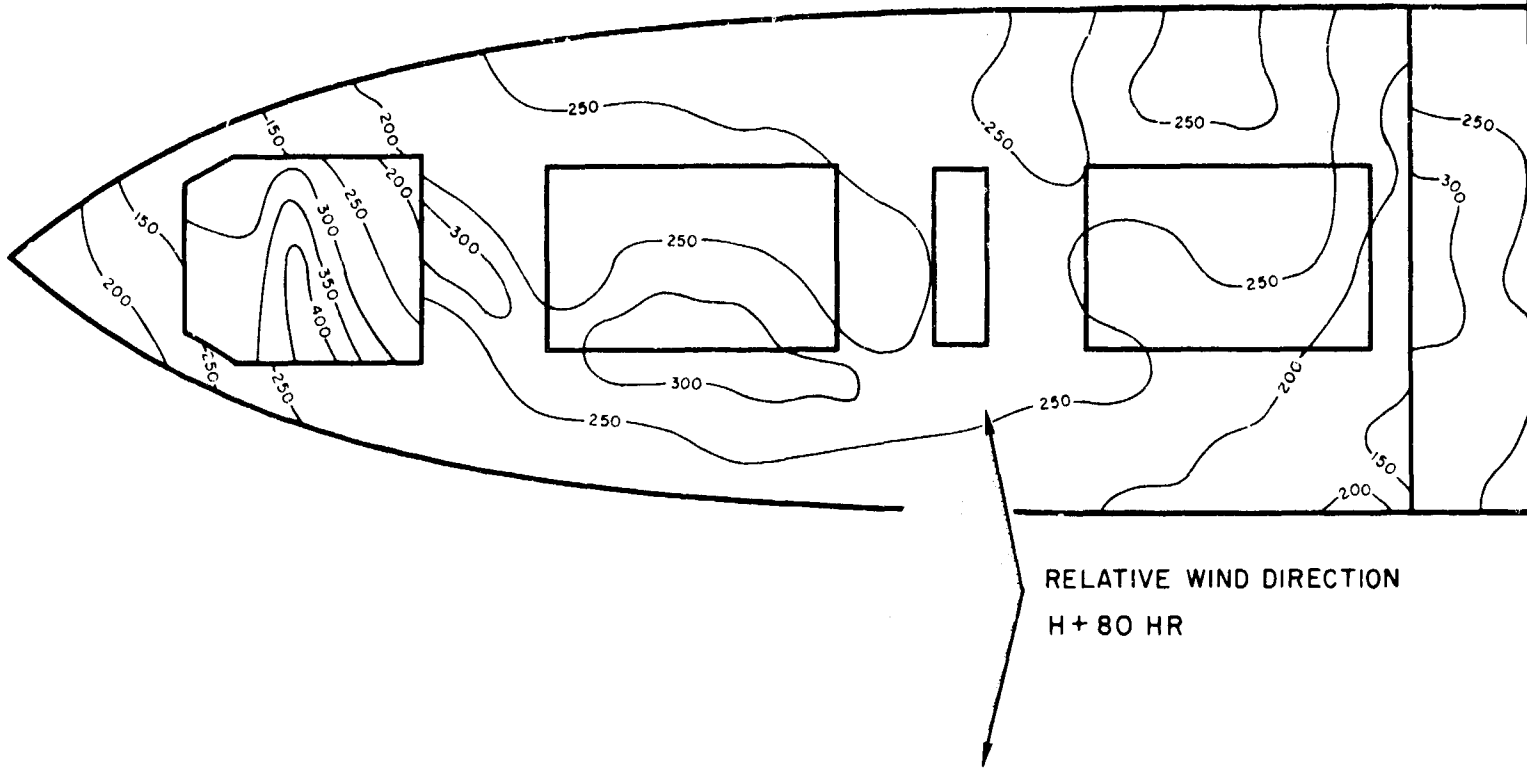

Figure 9.7 Radiation contours for

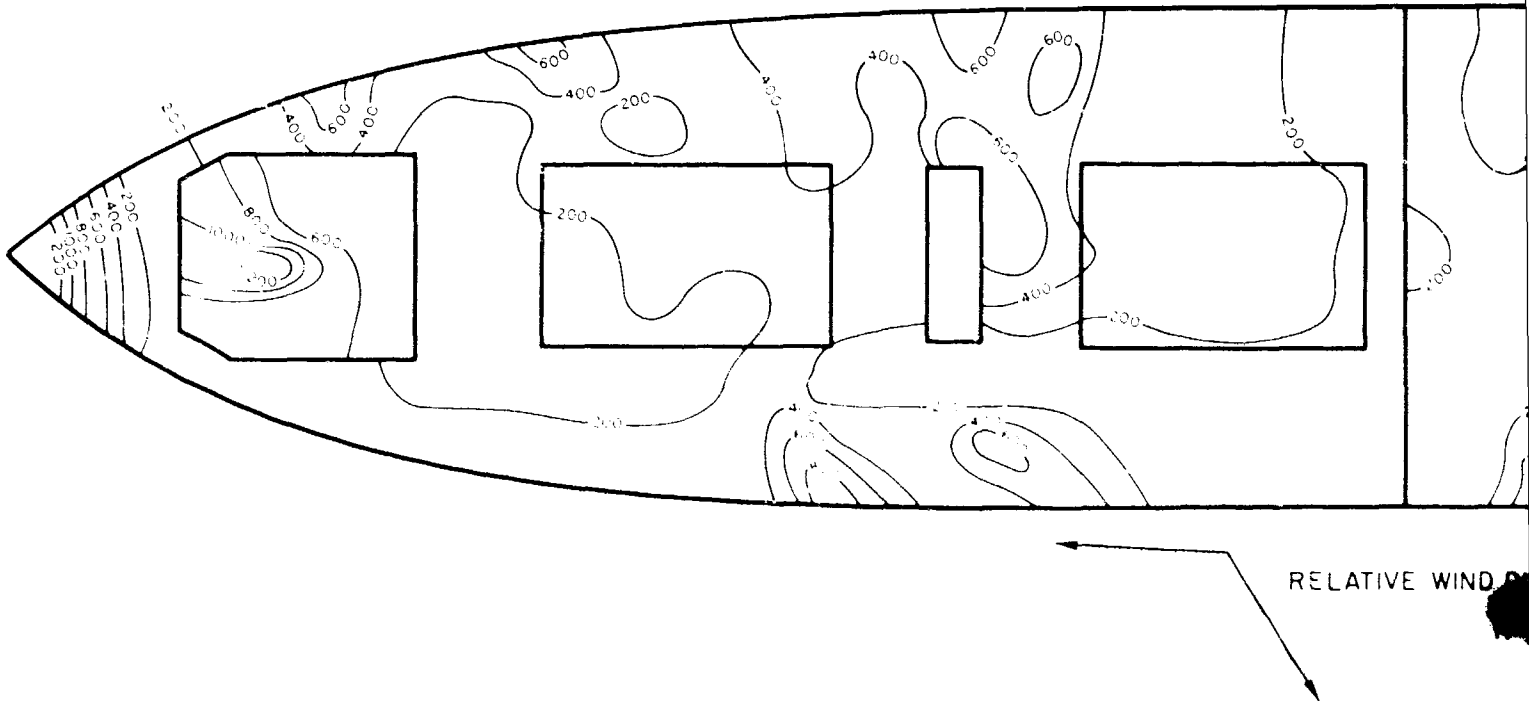
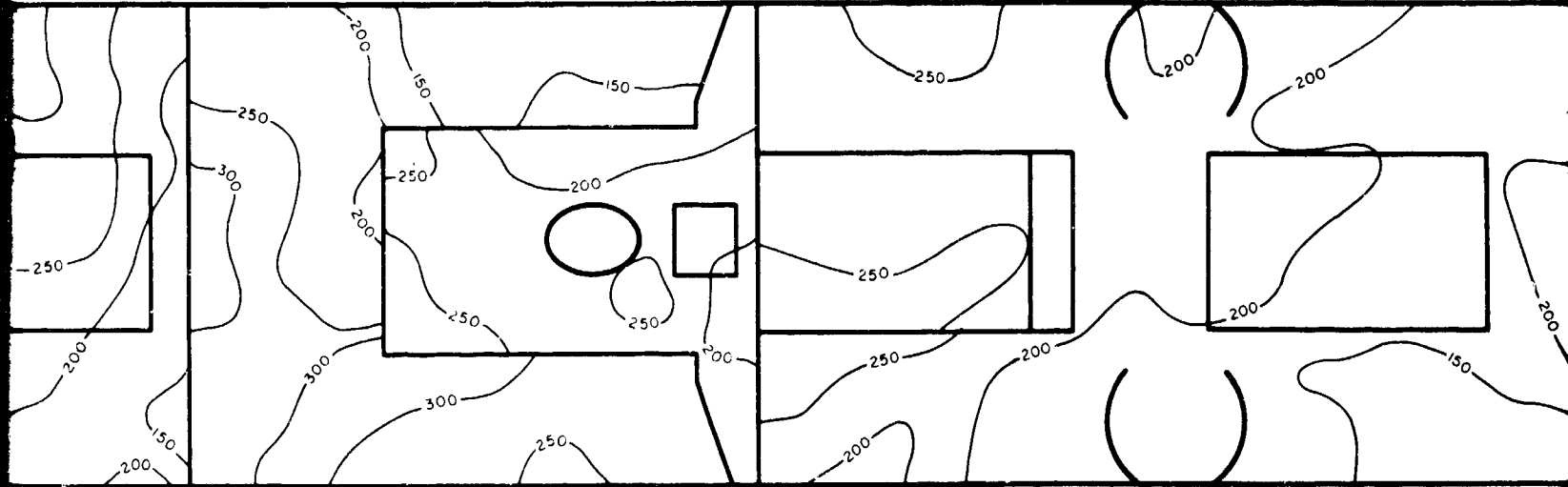

Figure 9.8 Radiation contours

CONFIDENTIAL

# CONFIDENTIAL



WIND DIRECTION

VALUES IN MR/HR

Radiation contours from original gamma survey on the YAG 40 after Shot 4. 29 April 1954.

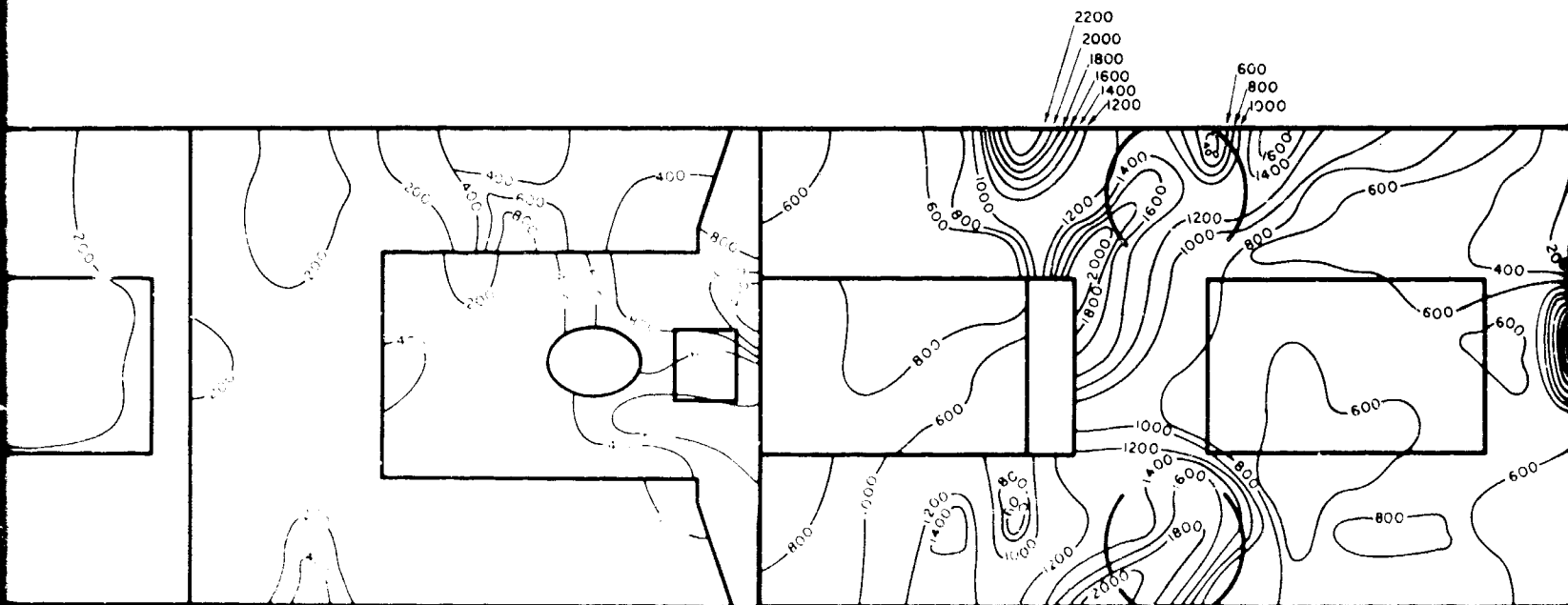

RELATIVE WIND DIRECTION

H + 76 HR

VALUES IN MICRO-AMPS

$1 \mu a \approx 1 \mu c$  ( $Sr^{90}$  POINT SOURCE STANDARD)

Radiation contours from original beta survey on the YAG 39 after Shot 5. 8 May 1954.

280

CONFIDENTIAL CONFIDENTIAL

2



CONFIDENTIAL

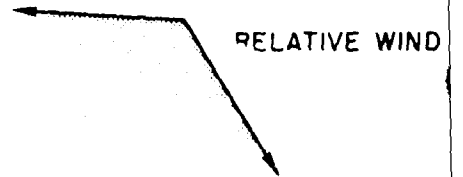
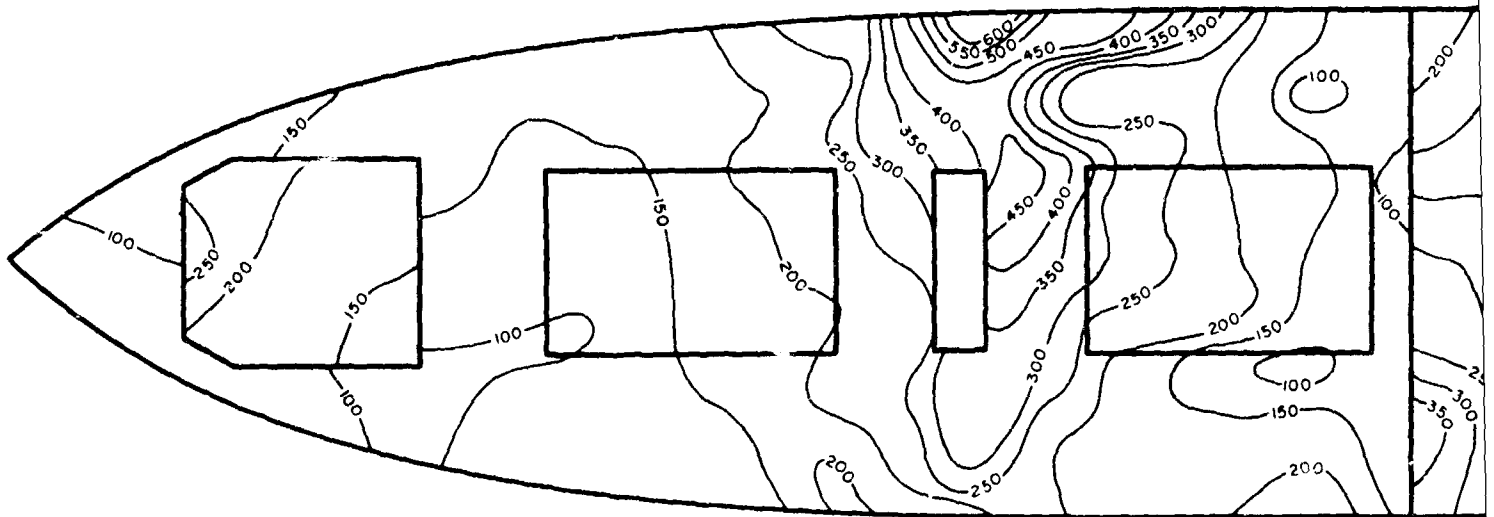
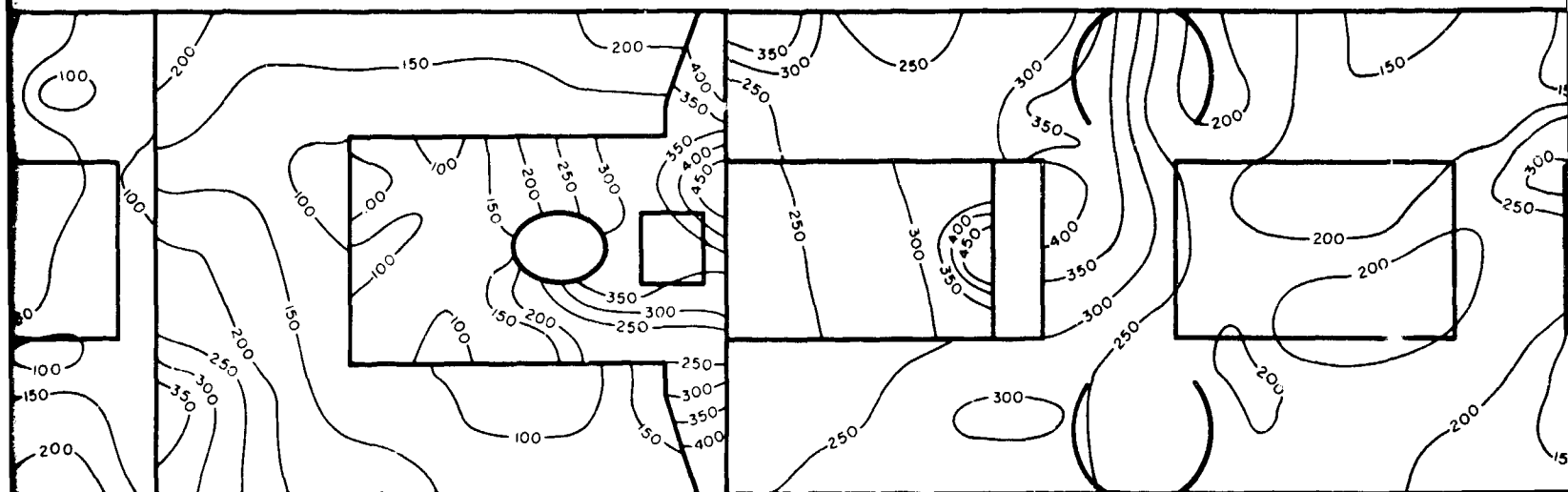

Figure 9.9 Radiation contour

CONFIDENTIAL

# CONFIDENTIAL



RELATIVE WIND DIRECTION  
H + 76 HR

VALUES IN MR/HR

radiation contours from original gamma survey on the YAG 39 after Shot 5. 8 May 1954.



CONFIDENTIAL

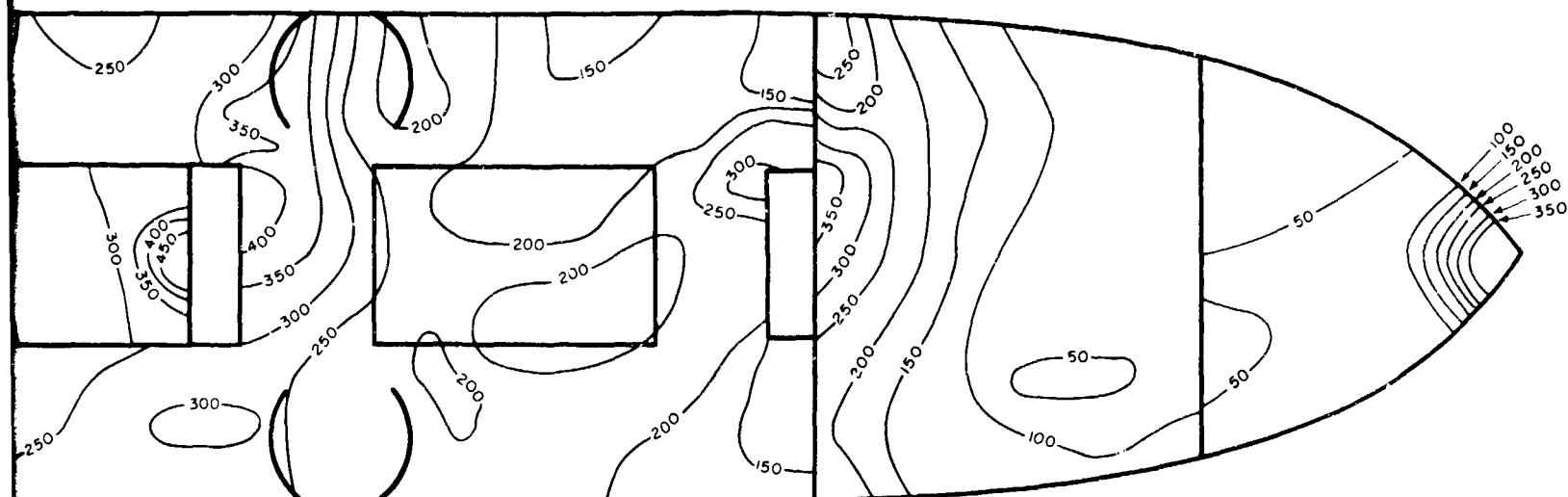

VALUES IN MR/HR

UAG 39 after Shot 5. 8 May 1954.

CONFIDENTIAL

3

CONFIDENTIAL

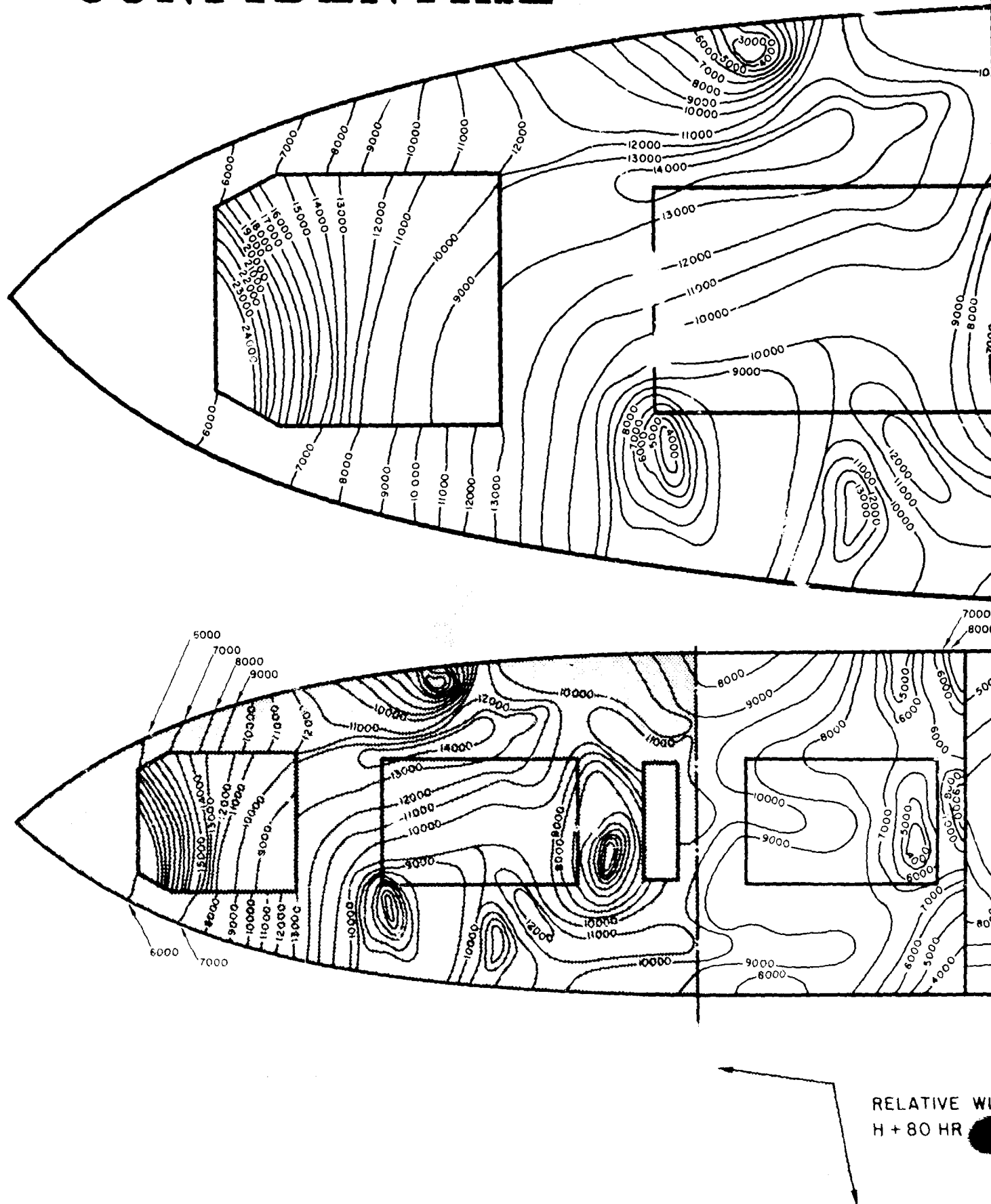
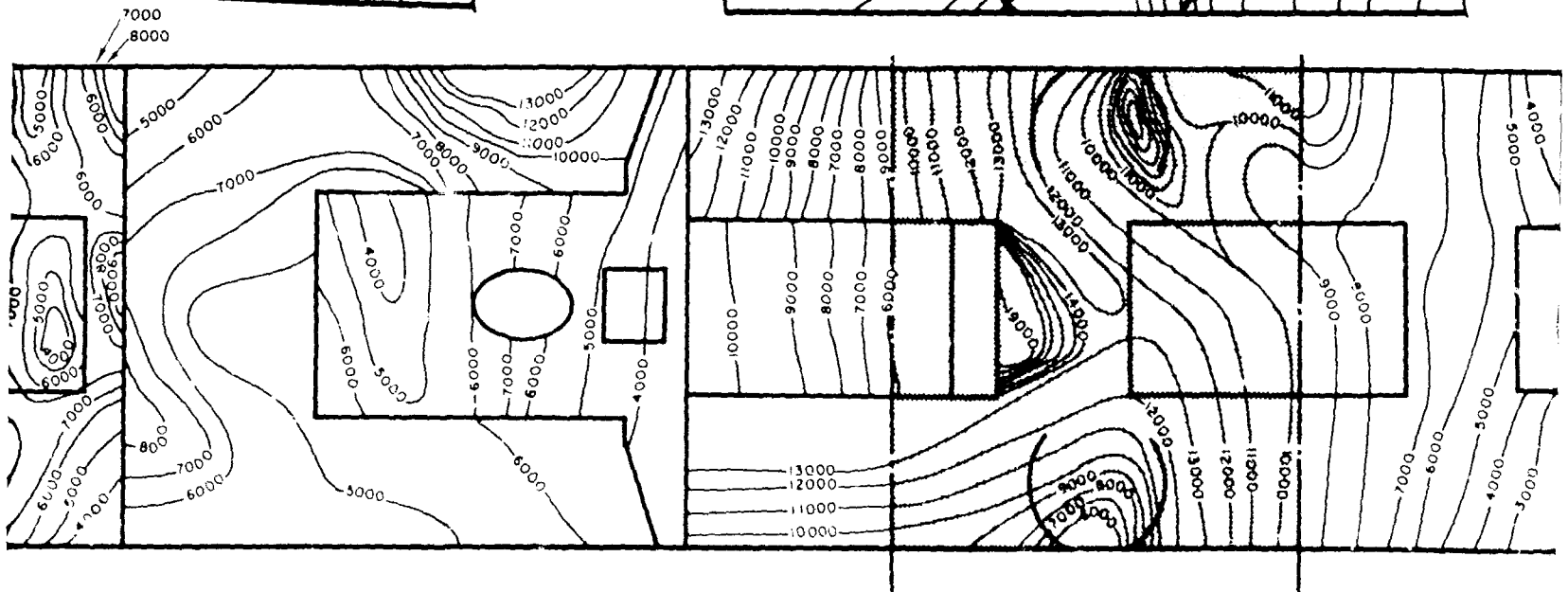
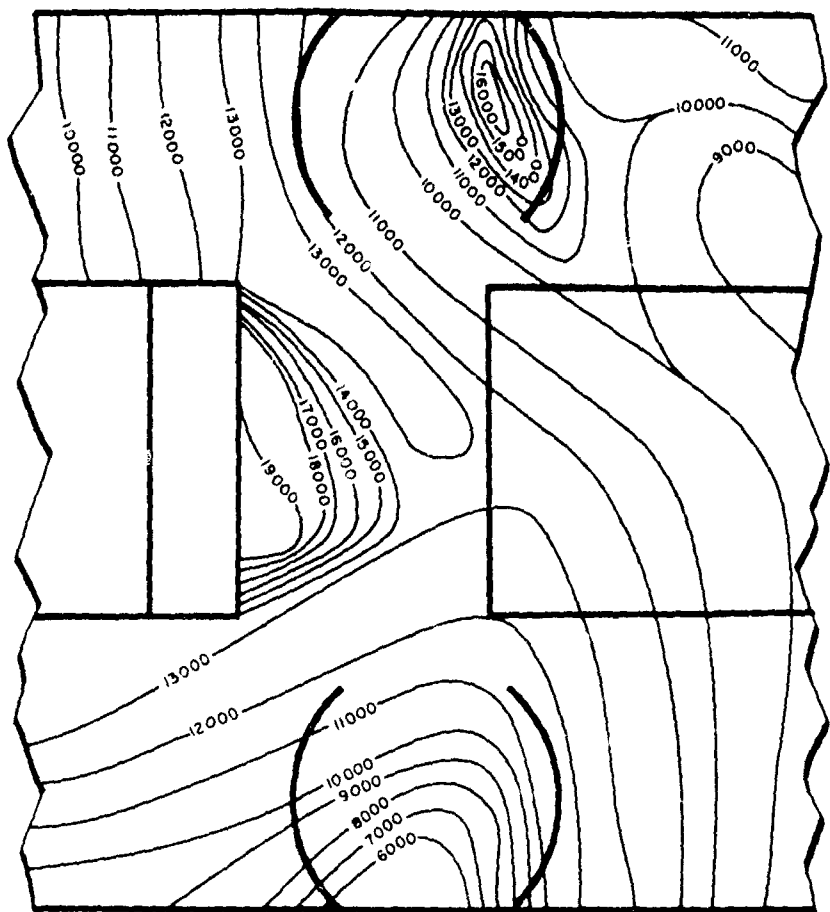
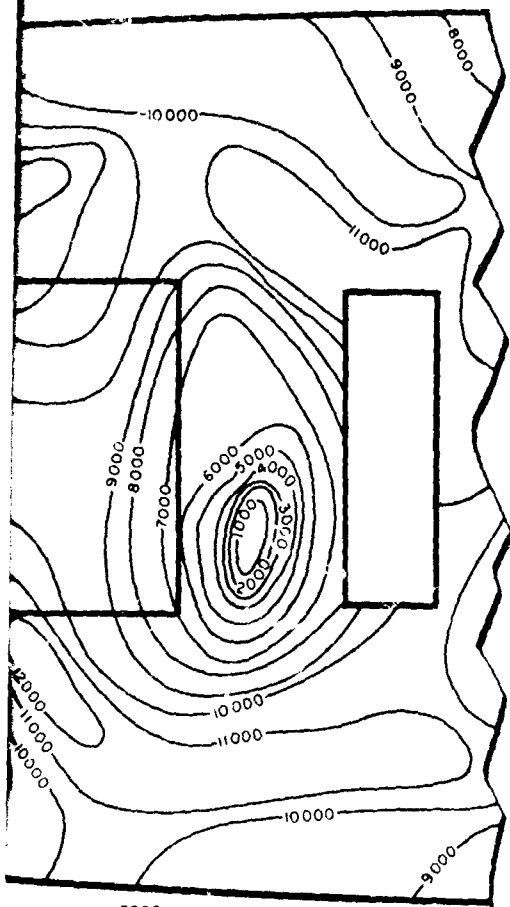

Figure 9.10 Radiation cont

CONFIDENTIAL

# CONFIDENTIAL



RELATIVE WIND DIRECTION  
1 + 80 HR

VALUES IN MICRO-AMPS

$1 \mu a = 1 \mu c$  ( $^{90}\text{Sr}$  POINT SOURCE STANDARD)

Location contours from original beta survey on the YAG 40 after Shot 5. 8 May 1954.

282

CONFIDENTIAL

CONFIDENTIAL

2

CONFIDENTIAL

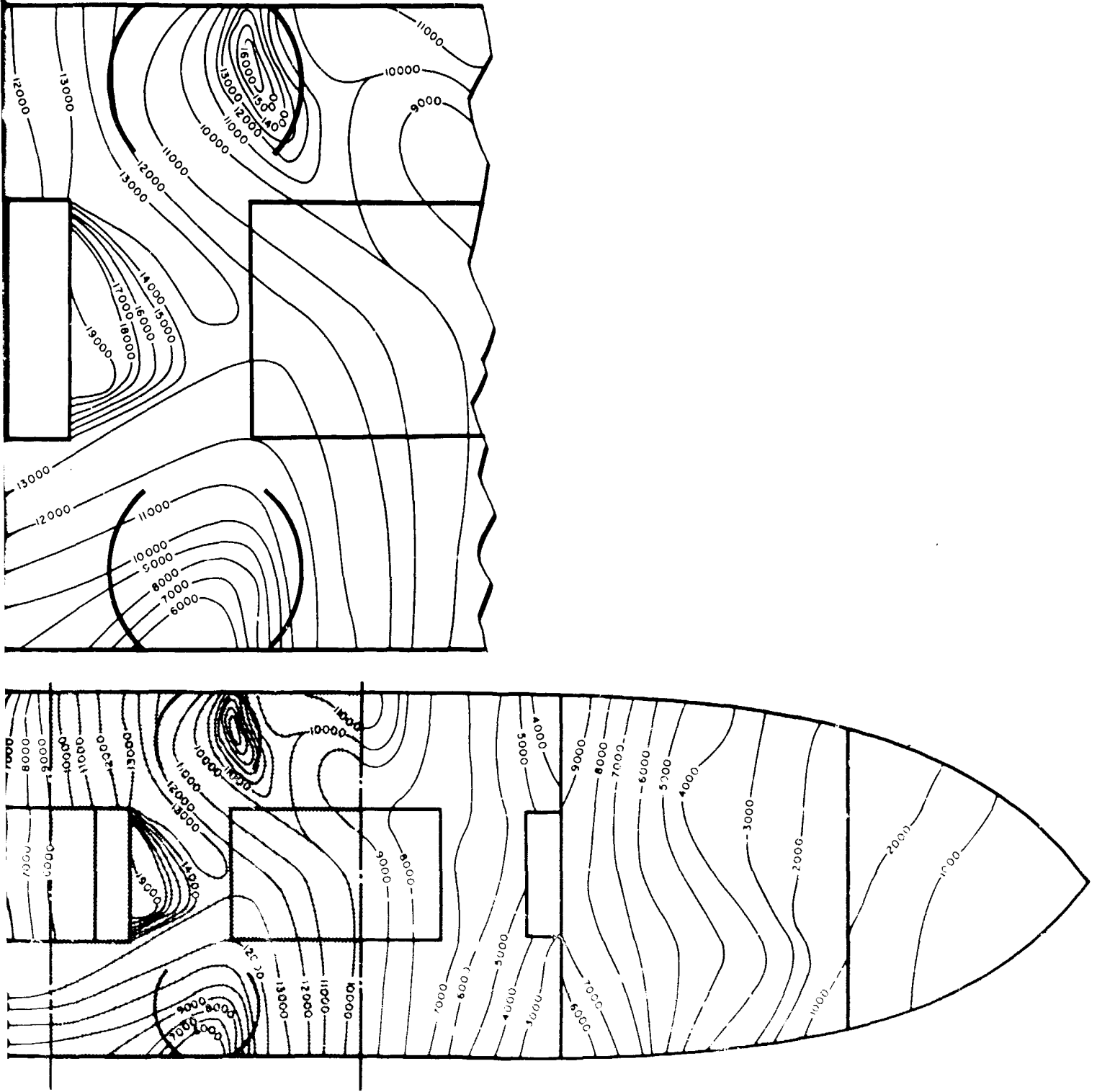

VALUES IN MICRO-AMPS

$\approx 1 \mu c$  ( $Sr^{90}$  POINT SOURCE STANDARD)

40 after Shot 5. 8 May 1954.

CONFIDENTIAL

CONFIDENTIAL

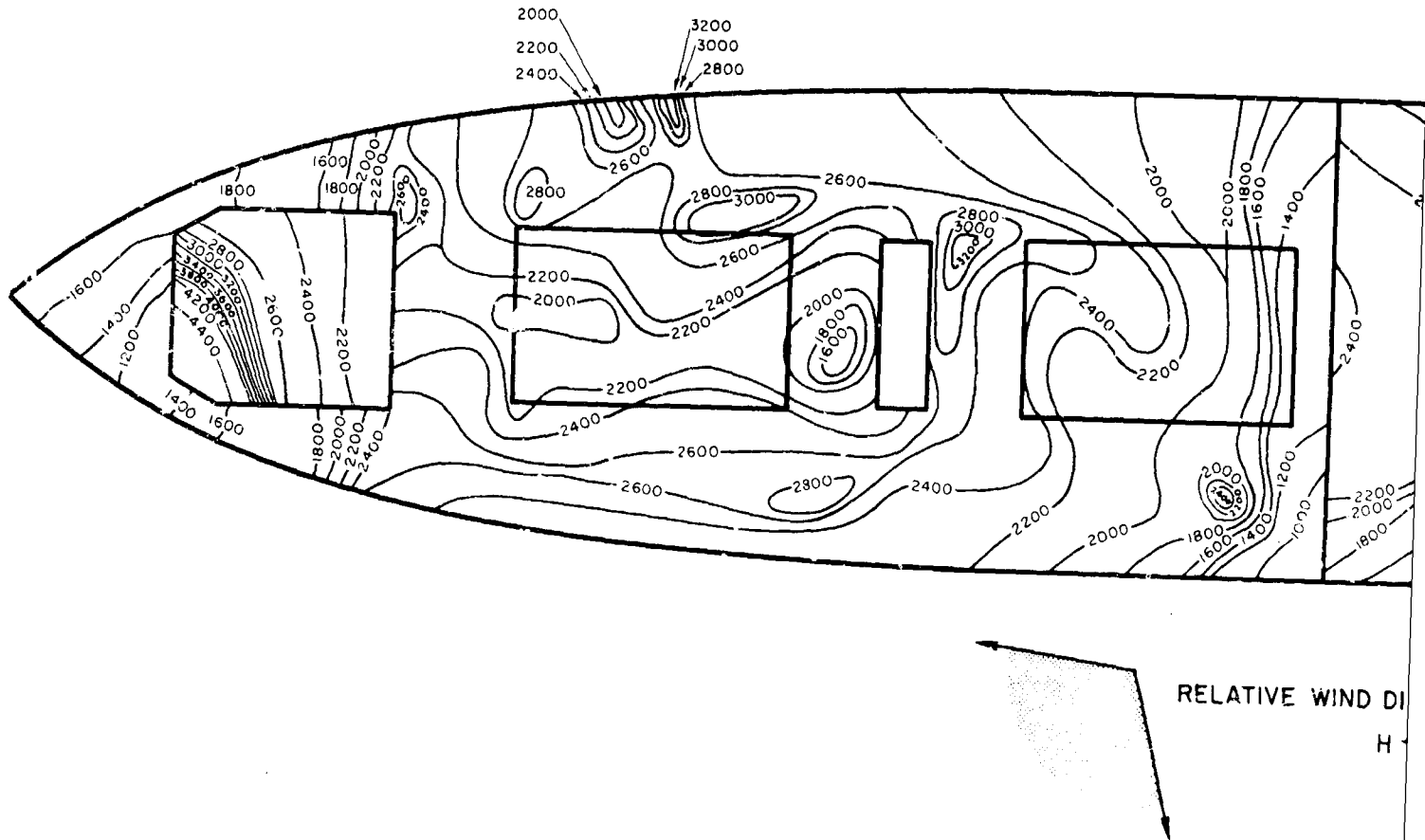
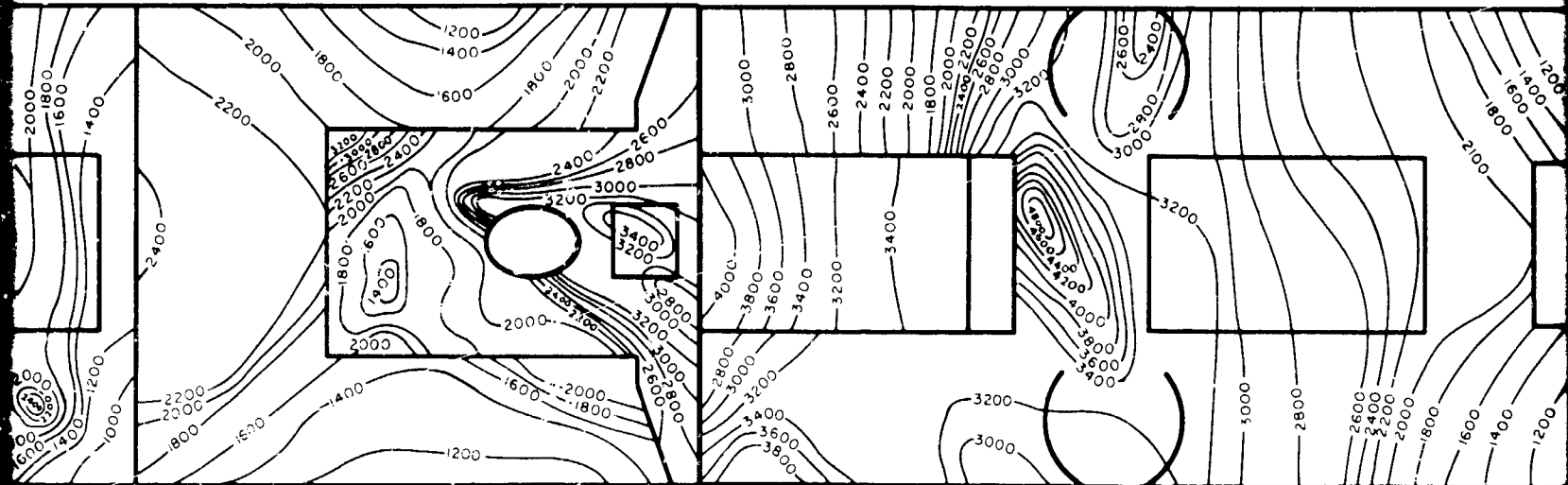

Figure 9.11 Radiation contour

CONFIDENTIAL

# CONFIDENTIAL



RELATIVE WIND DIRECTION  
H + 80 HR

VALUES IN MR/HR

ation contours from original gamma survey on the YAG 40 after Shot 5. 8 May 1954.

CONFIDENTIAL

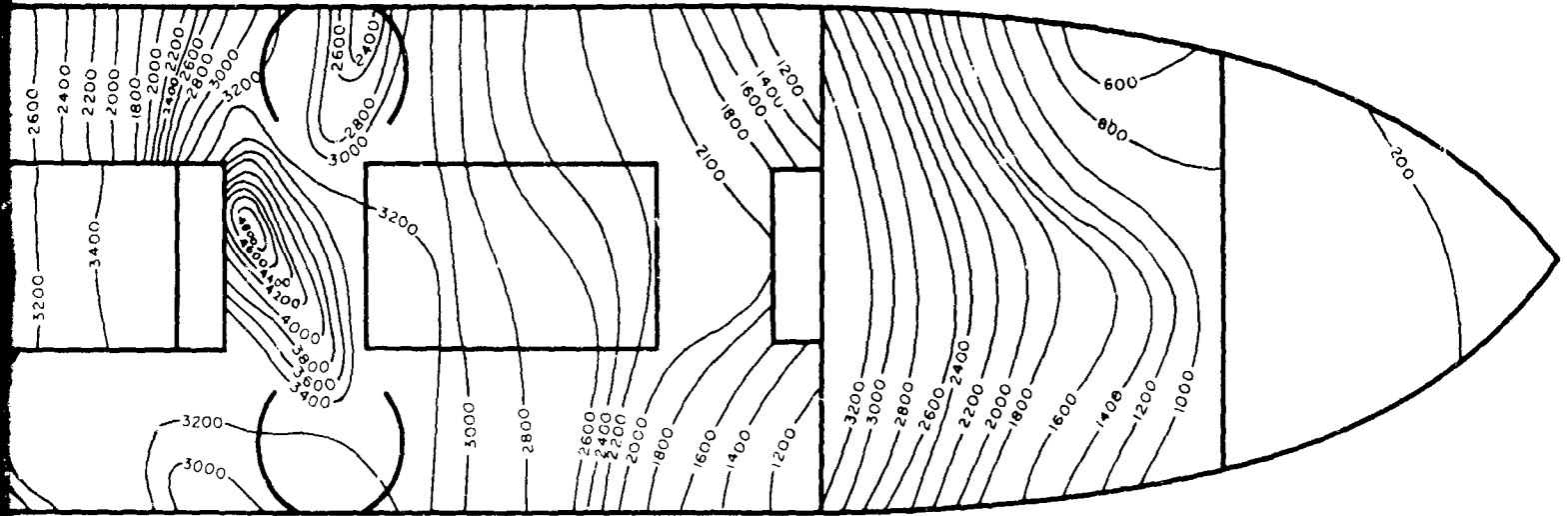

VALUES IN MR/HR

G 40 after Shot 5. 8 May 1954.

CONFIDENTIAL

3

gamma readings taken above surfaces in areas of relatively low background. Relatively good correlation is shown for beta and gamma decontamination factors.

Examination of other data showed that the ratio of beta-to-total-gamma (3 ft above deck) decontamination factors varied from 1 to 2 as indicated in Case 1.

Under the test conditions where it was necessary to determine decontamination effectiveness for specific surfaces, it is indicated that beta surface measurements are the most reliable. Better correlation between beta and gamma decontamination factors would probably have resulted if gamma measurements at deck level were taken.

In examining the data for Case 1, it was noted that the initial beta measurements varied by a factor of 73 from maximum to minimum, whereas the total gamma field max/min ratio was only 10. During the decontamination processes, the contamination was redistributed, as well as removed, and the final survey showed a beta max/min ratio of 15. The small area of measurement of the beta probe and the large variations in surface intensity indicate that a larger number of readings should be made to obviate localized influences.

9.4.3 Contamination Distribution. Shipboard beta intensity contours derived from surface measurements are shown in Figures 9.2, 9.4, 9.6, 9.8, and 9.10; gamma-intensity contours derived from measurements taken 3 ft above the deck are shown in Figures 9.3, 9.5, 9.7, 9.9, and 9.11.

These diagrams were made from beta and gamma readings taken at the same locations. Due to geometry and instrument characteristics, the beta diagrams are the best indication available of surface contamination distribution, while the gamma diagrams show the gamma field variations at a height of 3 ft above the deck.

The qualitative analysis of the radiation contour diagrams is best undertaken and discussed individually for each shot.

Shot 2, YAG 40

1. Beta contour curves before and after decontamination indicated that: (a) The intensely radioactive regions in the original curve were readily removed during the decontamination operations and did not reappear in any form in the subsequent diagram; and (b) Aside from the absence of the former hot spots, the relative trend of the countours although significantly reduced, was only slightly changed.

2. Gamma contours before and after decontamination were very much alike in shape with reduced values in the latter.

3. The general characteristics of the beta and gamma contours before decontamination were alike, but the extremely radioactive areas as designated by the beta contours did not show correspondingly high gamma areas.

4. Good correlation was found between the gamma and beta curves after decontamination.

The above information indicates that the original beta diagram was in error in the intensely radioactive regions. These regions should have been confined to small spots of intense activity within a relatively less-contaminated, semiuniform area. To improve the beta picture appreciably, the number of beta readings would be greatly increased.

Shot 4, YAG 40

1. Both beta and gamma diagrams showed relatively uniform contamination.



Shot 5, YAG 39

1. There were some indications of agreement between the beta and the gamma contour diagrams on the flight deck and on the top of the house.

2. Some high beta spots on the beta diagram were not recorded in the gamma diagram and some high gamma areas were not found to coincide with the beta diagram.

3. Deficiencies in the location and directionality of spray nozzles were indicated.

Shot 5, YAG 40

1. Good correlation was found between the beta and gamma diagrams except for the boat deck and the top of the house.

Collectively, it was found that the distribution of contamination depended upon the aerodynamic conditions at the time of contamination. On the YAG 40 it was noted that areas shielded from the wind received the least contamination. In large open areas, the activity increased from the windward to the leeward side. Contamination was noticeably high to windward and on the windward side of structures.

The residual contamination distribution on the YAG 39 also depended on washdown-nozzle locations, the composite aerodynamic effects, water runoff, and surface geometry.

9.4.4 Fallout Photographs. No gross fallout existed on the YAG 40 during the running time of the camera for all shots in which the ship participated. Small sparsely spaced particles were photographed intermittently in Shots 1 and 5. The particle sizes varied and were probably less than 100  $\mu$  in diameter and appeared to be in liquid form, as shown in Figures 9.12 through 9.15.

Because the 16-mm camera has a small film size, the sampling volume had to be small to obtain a useable resolution (1/12 actual size). This limit upon the sampling volume made it difficult, with the single flash per frame technique, to get a good picture of the sparse fallout phenomenon experienced by the YAG 40.

Poor resolution of the extremely small particles also made it difficult to determine the physical characteristics of the fallout. The films did show that the fallout as experienced by the YAG 40 was not a gross situation, as had been anticipated. The aerosol density (particles per unit volume) was very low.

It was impossible to correlate the photographed and detected radiation-fallout time interval because of the small number of particles photographed.

## 9.5 CONCLUSIONS

The survey group satisfactorily supplied radiological surveys for studies of washdown, contamination distribution, shielding, ventilation, boiler air, and decontamination.

The radiation contours showed that the contamination distribution aboard ship was dependent upon the aerodynamic characteristics of the structure.

Of the three gamma radiac instruments used in the surveys, the AN/PDR-TLB was the best for field operations.

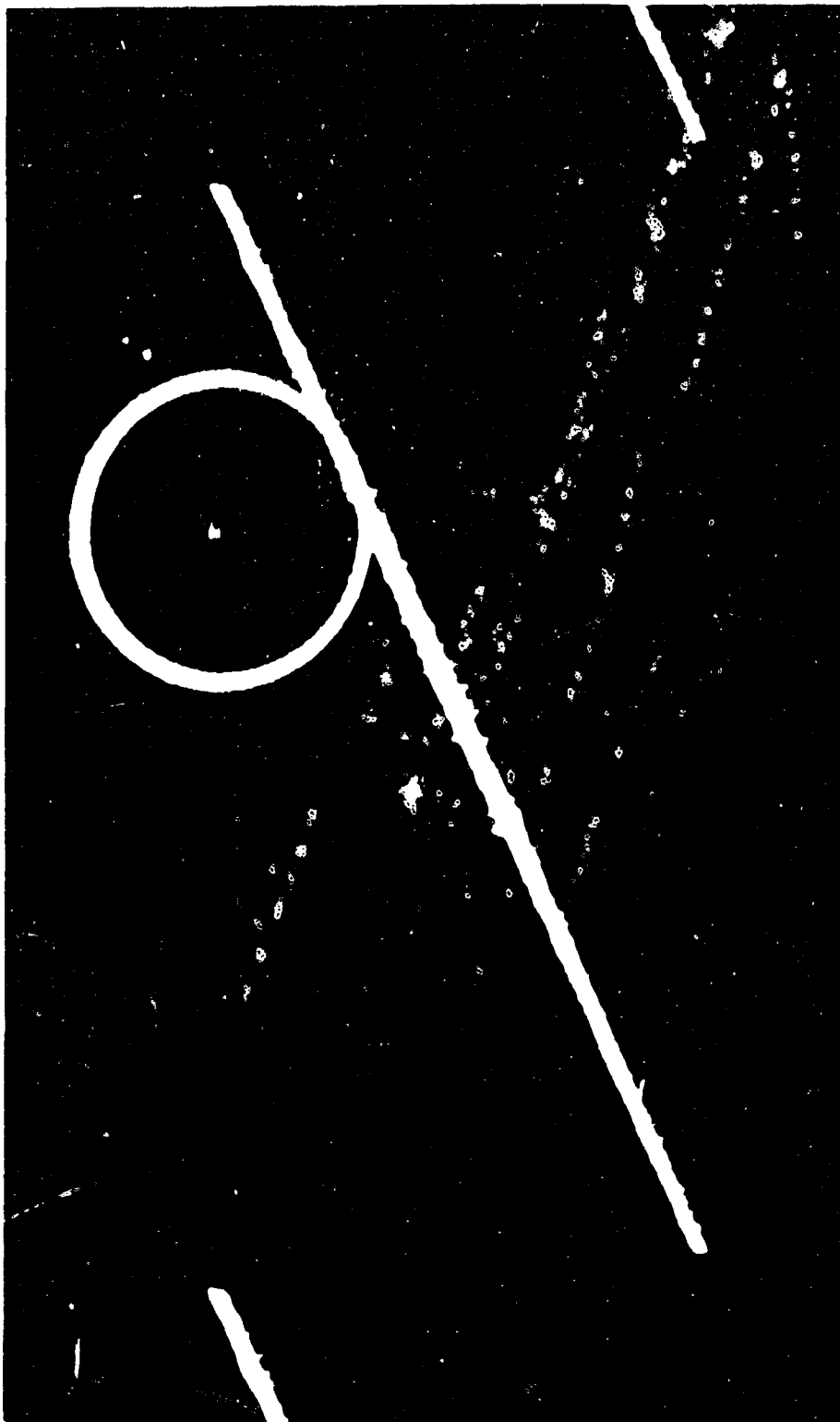

Figure 9.12 Fallout photograph enlarged (7.3X) from an aerosol camera frame from Shot 5.

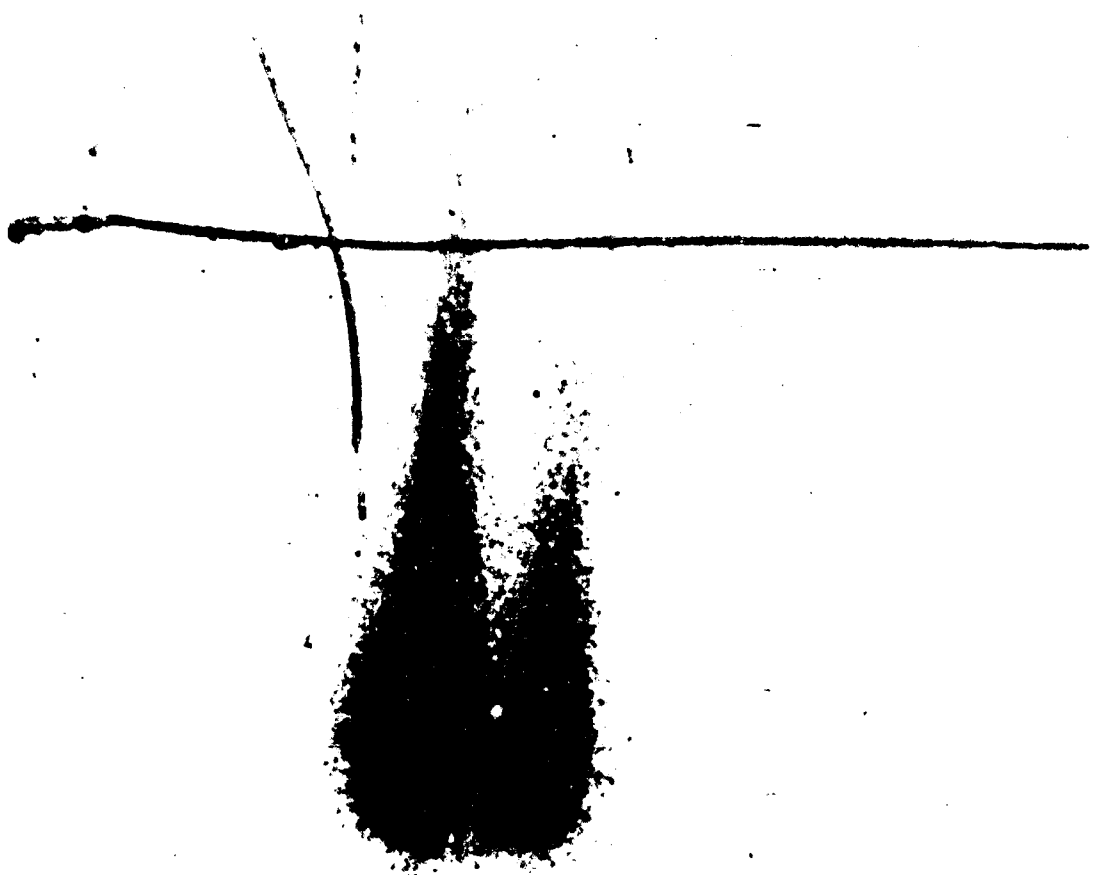

Figure 9.13 Photomicrograph (90 X) of circular area of Figure 9.12, showing double image characteristic of a clear liquid droplet.

## 9.6 RECOMMENDATIONS

Radiological surveys should be conducted under a survey group to render services for the entire project.

The number of beta measurements should be greatly increased to give a proper beta-contamination distribution contour diagram.

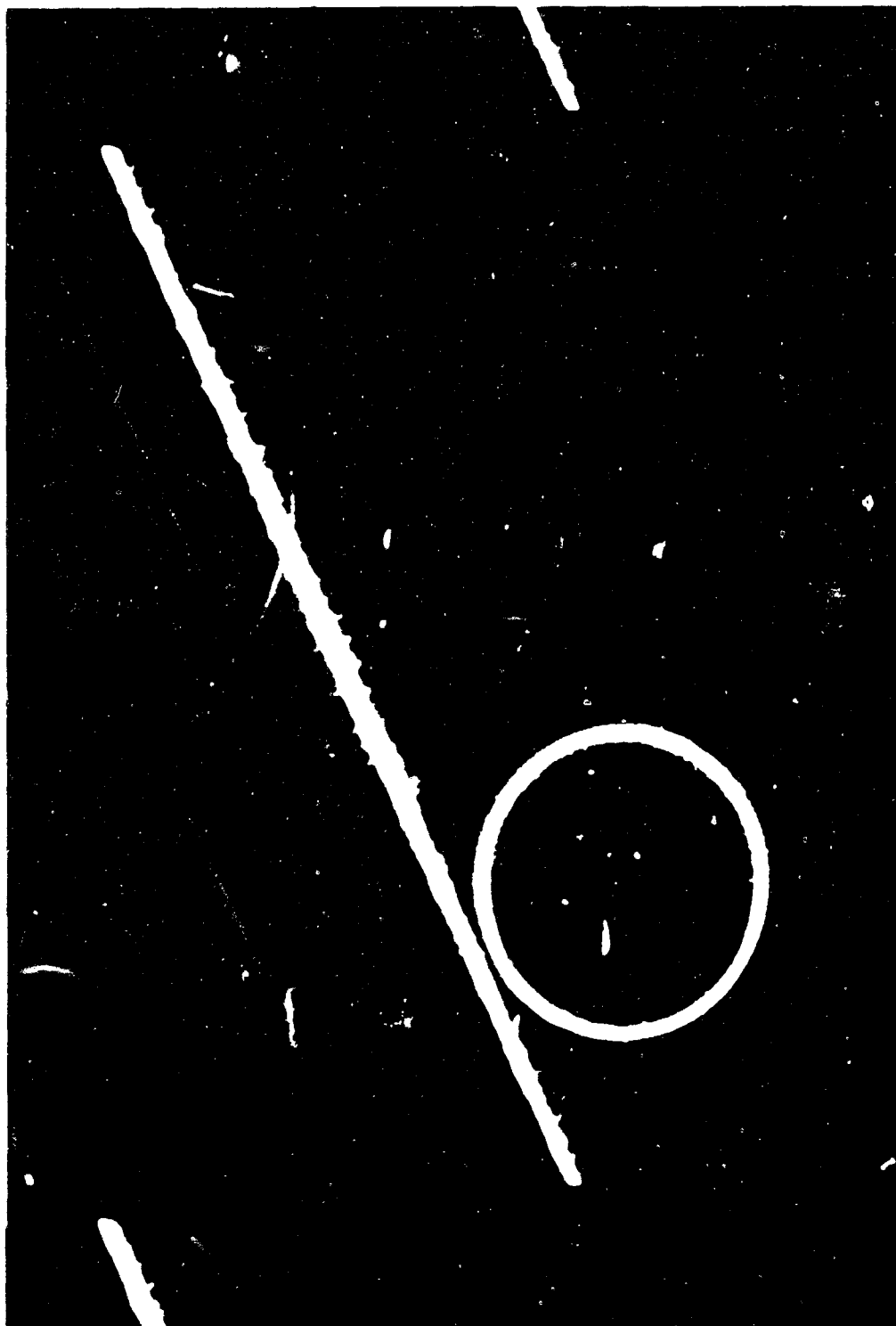

Figure 9.14 Fallout photograph enlarged (7.3 X) from an aerosol camera frame from Shot 5.

The NRDL RBI-12 beta probe should be of sturdier construction for field use.

The directional gamma probe in its present condition should not be used in field tests. Feasibility of further development of this instrument should be determined.

A photomicrograph showing three small, dark, irregularly shaped particles. One particle is located in the upper left quadrant, another in the lower center, and a third, smaller one in the lower right quadrant. The background is light and grainy.

Figure 9.15 Photomicrograph (90 X) of circular area of Figure 9.14 showing three small particles.

# Chapter 10

## RADIOLOGICAL PROTECTION OF PERSONNEL

A. L. Baletti

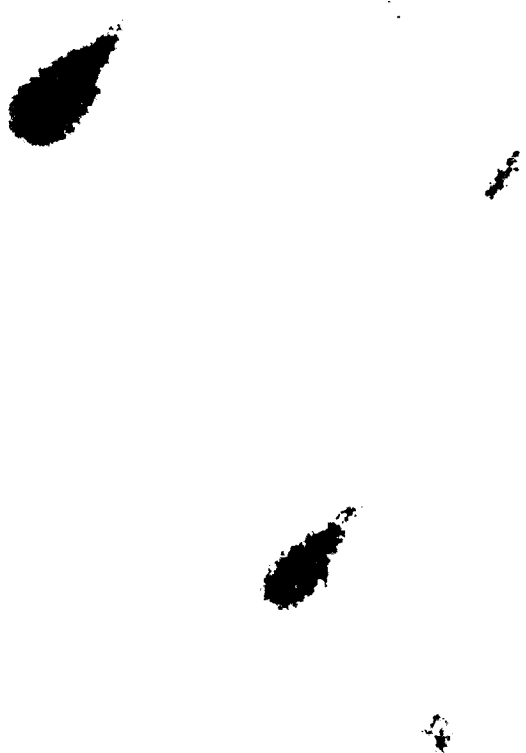
Provisions for adequate radiological safety coverage for all Project 6.4 operations and evaluation of existing rad-safe procedures, techniques, and instrumentation for their suitability under tactical decontamination conditions are discussed. Information to aid in the development of new and improved radiological safety techniques and instruments is also presented. Recommendations are made concerning equipment and procedures to improve radiological safety support for future field operations.

It was determined that it is feasible to estimate the average radiation level aboard a contaminated ship on the basis of dose-rate measurements taken from another nearby vessel. Support was given to the various decontamination operations to assure the safety and protection of personnel from undue exposure to radiological hazards. Protective clothing was provided and control points established to minimize the spread of contamination. A personnel decontamination center was provided to ensure adequate decontamination of personnel. Special film-badge studies were made to evaluate badge holders and interpretive procedures for field operation usage. In addition, beta-exposure data were collected in an attempt to determine the significance of such exposure. Also, an attempt was made to collect dosage information associated with specific decontamination and recovery operations. Instrumentation for dose-rate and contamination measurements were provided. Some measurements were made on general contamination and radiation levels detected in various parts of the test area.

### 10.1 BACKGROUND

In past field operations involving nuclear weapons, radiological safety was considered primarily as a service organization. Although providing adequate support to the test program is indeed a basic and important mission of any rad-safe organization, an effort should be made to evaluate and improve the service. Project 6.4, Operation Castle presented an opportunity for such an evaluation on a limited scale. The scope of the Project 6.4 program was broad enough to provide sufficient opportunity for diversified application of various rad-safe principles and to furnish some evaluative information.

### 10.2 OBJECTIVE

The objective of the rad-safe phase of Project 6.4 was two-fold: (1) to provide adequate radiological safety coverage for all Project 6.4 operations, thereby minimizing the personnel hazard associated with

the various tests, and (2) to evaluate existing radiological safety procedures, techniques, and instrumentation for their suitability under tactical decontamination conditions and to obtain information toward development of new and improved radiological safety techniques and instruments.

### 10.3 WORK OF THE PROJECT 6.4 RAD-SAFE GROUP

Since the radiological safety coverage for the entire scientific program at Operation Castle was provided by TU-7 personnel, it was possible for the Project 6.4 rad-safe group to spend its time on the above objectives, rather than becoming involved in the broader scope of the rad-safe problems generated by the complete scientific program.

To accomplish the first objective, the group provided the necessary radiological safety control during the recovery operations of the test ships, during decontamination operations aboard them, and during those carried out on Site Fred. The second objective was fulfilled by the research efforts of the group directed principally toward photodosimetry, airborne activity, and evaluation of the rad-safe instruments.

Details of both the radiological safety coverage provided by the group and its research efforts are discussed in the subsequent seven sections.

10.3.1 Recovery Operations of the Test Ships. The nature of Project 6.4 made it necessary to conduct monitoring surveys during the recovery of the YAG 40 after each contaminating event. A monitoring pass was made by the recovery ATF to determine the extent of the radiation hazard, and additional measurements were made aboard the ATF during the actual recovery operation. Table 10.1 summarizes the radiation fields

TABLE 10.1 RADIATION LEVELS DURING RECOVERY, YAG 40

Shot	Max. Radiation Level Observed Aboard Tug During Recovery (r/hr)	Calculated av. Topside Radiation Level Aboard YAG 40 at Recovery (r/hr)	Airborne Contamination <sup>(a)</sup> in Recovery Area (μc/cc)
1	0.004	0.040	$2 \times 10^{-7}$
2	1.0	8	$3.6 \times 10^{-10}$
4	0.15	4	$1.0 \times 10^{-6}$
5	0.90	22	$2 \times 10^{-7}$

(a) Measured aboard ATF-106.

observed aboard the ATF and lists the calculated radiation flux aboard the YAG 40 at the time of recovery. Details of the techniques involved in estimating the radiation flux aboard the YAG 40 are given in Appendix H.

The tow pickup lines and manila messengers were found to be highly contaminated. The radiation levels on these lines averaged 10 to 20 r/hr at the surface.

Although many arbitrary factors enter into the estimation of the radiation flux aboard the YAG 40 at the time of recovery, it is interesting to note that order of magnitude agreement was achieved when the average

topside radiation intensity measured at a later time was corrected for decay and compared with the estimated dose rate. Table 10.2 lists these two corresponding values.

TABLE 10.2 RADIATION LEVELS ABOARD YAG 40

Shot	Calculated Average Topside Radiation Level Aboard YAG 40 at Recovery (r/hr)	Average Topside Radiation Level Measured Aboard YAG 40. (Corrected for Decay) (r/hr)
2	8	6
4	4	1
5	22	17

Table 10.3 summarizes the various dosages received by personnel during the recovery operations.

YAG 39 personnel returned to Site Elmer aboard the YAG 39 after each of the shots listed in Table 10.3. The crew on the YAG 40

TABLE 10.3 PERSONNEL DOSAGES DURING RECOVERY

Shot	Average Dosage of ATF-106 Personnel During YAG 40 Recovery (mr)	Average Dosage of Personnel Remaining on YAG 39 During Event (mr)	Average Dosage to YAG Crews Participating in Recovery Operations (mr)	
			YAG 39	YAG 40
1	116	-	123	233
2	226	-	165	279
4	544	1905	945	754
5	266	4741	4027	637

returned to Elmer aboard the YAG 39 after Shots 2 and 4 and aboard the ATF 106 after Shots 1 and 5. The average topside radiation level of the YAG 40 was 25 mr/hr prior to participation in Shot 4 and 75 mr/hr prior to Shot 5. This residual radiation field was responsible for part of the dosage received by YAG 40 personnel for these two events, as shown in Table 10.3.

10.3.2 Aboard the Test Ships. The radiological safety program was concerned with protection measures on behalf of personnel working or living aboard the two test ships in the presence of radioactive contamination. Inasmuch as all of the radioactive contamination was initially confined to the weather surfaces, the problem of rad-safe protection resolved itself into contamination and dosage control topside and dosage control below decks.

To effect dosage control a daily, complete zone survey was made of all areas on board the two ships and dosages were estimated on the basis of these surveys. The same selected check points were monitored each day. All routine surveys were made at waist height, where it is considered the average dosage is received. All routine measurements were for gamma only, inasmuch as the task force dosage limits were for gamma only. Routine surveys were useful in predicting dosage to personnel and in setting stay times for work parties. All radiation levels were plotted on an overlay drawing of the deck plans



to enable interested parties to obtain dose-rate information quickly. Tables 10.4 and 10.5 indicate the average radiation levels and airborne contamination levels aboard the YAG 39 and YAG 40 during the various decontamination and recovery operations.

TABLE 10.4 YAG 39 RADIATION LEVELS

Date	Topside Average Radiation Level (mr/hr)	Interior of Ship and Below Deck Average Radiation Level (mr/hr)	Air Contamination (μc/cc)
Shot 1, 3-3-54	15	1	9.6 x 10 <sup>-10</sup>
3-4-54	10	-	6.1 x 10 <sup>-10</sup>
Shot 2, 3-29-54	5	1	2.6 x 10 <sup>-9</sup>
4-1	15	40	-
4-2	90	13	3.8 x 10 <sup>-9</sup>
4-3	52	-	-
4-5	47	9	1.1 x 10 <sup>-8</sup>
4-6	25	-	3.4 x 10 <sup>-9</sup>
4-8	23	8	-
4-9	12	-	1.3 x 10 <sup>-9</sup>
Shot 4, 4-30-54	17	7	6.4 x 10 <sup>-9</sup>
5-3	5	1	-
Shot 5, 5-6-54	552	136	2.5 x 10 <sup>-9</sup>
5-7	292	52	-
5-8	217	50	-
5-9	169	19	-
5-10	78	13	-
5-11	60	11	6.0 x 10 <sup>-9</sup>
5-12	39	6	-
5-13(a)	118	16	-
5-15(a)	92	12	-
5-16(a)	91	11	1.7 x 10 <sup>-9</sup>
5-18(a)	37	11	-
5-19(a)	27	-	-
5-20	26	8	-
5-21	24	-	-
5-22	8	2	-
5-25	8	2	-
5-27	8	1	-
5-30	5	1	-
6-2	5	1	-
6-4	4	1	-
6-11	3	1	-
6-18	4	1	-

(a) YAG 39 moored alongside YAG 40.

The ratio of beta plus gamma radiation level to the gamma radiation level was determined by special surveys with the "Cutie Pie" survey meter. The ratio was found to vary from 10 to 30 at topside deck levels and from 3 to 5 at waist levels.

The film badge was the final criterion for dosage control. Film dosage records were maintained on a daily basis, and as personnel exposures approached the permissible limit, replacements were obtained. Table 10.6 indicates the average daily dosages received by NRDL and YAG personnel who were concerned with the decontamination and recovery programs.

Table 10.7 indicates the average daily dosage increments received by Task Force personnel who actively engaged in YAG decontamination operations.

Contamination control was accomplished by use of adequate protective equipment and by delineation of contaminated zones from clean zones.

For entry into contaminated zones wherein large amounts of removable contamination were involved and for normal, dry work in those zones, the

TABLE 10.5 YAG 40 RADIATION LEVELS

Date	Topside Average Radiation Level (mr/hr)	Interior of Ship and Below Deck Average Radiation Level (mr/hr)	Air Contamination ( $\mu\text{c}/\text{cc}$ )	
Shot 1, 3-2-54	14	-	-	
	5	2	$7.0 \times 10^{-11}$	
Shot 2, 3-30-54	2320	92	$8.5 \times 10^{-8}$	
	3-31	1560	-	
	4-1	570	90	-
	4-2	552	-	-
	4-5	187	-	$3.5 \times 10^{-6}$
	4-6	120	27	$8.1 \times 10^{-9}$
	4-9	106	-	$6 \times 10^{-10}$
	4-10	70	20	-
	4-12	55	12	$2.9 \times 10^{-8}$
	4-13	46	11	$7.0 \times 10^{-9}$
	Shot 4, 4-28	350	-	-
4-29		203	29	-
5-1		138	-	-
5-3		91	26	-
Shot 5, 5-7-54	4480	385	-	
	5-8	3690	199	-
	5-11	1490	178	-
	5-13	724	170	-
	5-15	515	105	-
	5-16	406	94	-
	5-17	257	66	$3.5 \times 10^{-8}$
	5-18	146	21	-
	5-19	101	19	-
	5-20	86	14	-
	5-21	62	11	$4.0 \times 10^{-8}$
	5-24	44	6	-
	5-26	49	8	-
	5-27	35	6	-
	5-31	32	5	-
	6-2	25	4	-
	6-5	19	3	-
6-8	23	4	-	
6-12	17	3	-	

following rad-safe protective clothing was worn: underwear, socks, shoes, coveralls, caps, cotton gloves, and canvas shoe covers or rubber overshoes. For wet decontamination work involving water spray, plastic suits and face shields affording complete body protection against liquids were worn as needed. In certain wet decontamination work where the men were not subjected to water spray, rubber boots and rubber gloves in conjunction with coveralls provided an adequate barrier to contamination.

After decontamination of the weather surfaces removed the loose contamination, it was found that the use of the rad-safe shoes without outer coverings in the contaminated zone was feasible, and shoe contamination remained below the established limits. In general, the protective

TABLE 10.6 DOSAGE INCREMENTS, YAG AND MRDL PERSONNEL

Shot	Average Dosage (mr)
1	170
2	1030
4	1100
5	2600

TABLE 10.7 AVERAGE DAILY DOSAGE RECEIVED BY  
YAG DECONTAMINATION PERSONNEL

Date	No. Dosages Averaged	Average Dosage (mr)	Date	No. Dosages Averaged	Average Dosage (mr)
3-1-54	4	120	4-25	-	-
3-29	1	85	4-26	-	-
3-30	5	210	4-27	-	-
3-31	41	957	4-28	6	150
4-1	56	427	4-29	31	285
4-2	64	368	4-30	2	58
4-3	3	433	5-1	4	123
4-4	33	347	5-2	10	311
4-5	53	392	5-3	-	-
4-6	14	222	5-4	-	-
4-7	24	163	5-5	1	275
4-8	42	941	5-6	-	-
4-9	30	385	5-7	-	-
4-10	7	229	5-8	43	43
4-11	16	440	5-9	28	213
4-12	3	365	5-10	19	177
4-13	7	367	5-11	27	254
4-14	13	388	5-12	25	97
4-15	3	167	5-13	15	77
4-16	-	-	5-14	3	200
4-17	-	-	5-15	-	-
4-18	-	-	5-16	21	610
4-19	2	60	5-17	14	539
4-20	-	-	5-18	7	364
4-21	1	40	5-19	6	448
4-22	-	-	5-20	5	209
4-23	-	-	5-21	6	206
4-24	-	-			

clothing requirements varied with the degree of removable contamination present.

The control-zone system was used to minimize spread of radioactive contamination. The contaminated, or controlled, zones were delineated with rope or other barriers and check stations were set up at the entrance and exit points of such zones. At these points, all personnel moving from the controlled zone to the uncontrolled or uncontaminated zone were monitored, and contaminated clothing was removed to prevent spread of contamination.

All decontamination operations conducted aboard the YAG 40 were controlled from the YAG 39, which was moved alongside and used as a boarding ship. A contamination control zone was roped off on the YAG 39, and a contamination check station was set up at the boundary of the zone. All movement of personnel and equipment from the YAG 40 was through the YAG 39 control zone. Extra supplies of protective clothing were maintained at the YAG 39 check station. Where possible, the contaminated clothing worn by personnel were replaced with clean clothing prior to the return of personnel to the Elmer Rad-Safe Building for final personnel decontamination. This system effectively minimized personnel skin contamination and the spread of contamination to clean zones.

A change system for shoe covers was initiated to minimize tracking of contamination below decks of the YAG 40 and of the YAG 39 when the contamination status of the YAG 39 warranted such precautions. However, some low-level removable contamination was introduced to the below deck areas, due to the initial effects of the fallout and by tracking from above decks.

No major decontamination of the YAG 39 was necessary, except after Shot 5. In this case, the ATF 106 was used as the boarding ship and rad-safe operations and control similar to that described above for the YAG 40 was carried out.

On the basis of the results of the air-sampling program, it was determined that respiratory protection was not required, except in the case of personnel who were actively engaged in the operation of the wood surface removal (Tennant) machine. These operators wore full-face Army M9A1 or the Navy MKV mask, interchangeably.

Rad-safe indoctrination and advice was given to appropriate Project 6.4 personnel, including those obtained from other ships to carry out the various decontamination operations. Depending on the radiological conditions and type of work to be done, wrist badges and pocket dosimeters were issued in addition to the standard body film badges.

Protective clothing and rad-safe instrumentation were supplied to the YAG 39 and YAG 40 for the return trip to the Zone of the Interior. For the trip all crew members wore badges, which were changed at Pearl Harbor. Rad-safe regulations were documented and supplied to each ship for the protection and guidance of the crew. Eating and smoking rules and contamination control measures were established. A ship-monitoring schedule was established, by which those crew members who had been trained in radiological safety work in the field operation were employed, to conduct the monitoring surveys. A schedule for monitoring of personnel for possible contamination was instituted.

Urine samples were collected from all YAG crewmen upon return to the Zone of the Interior. No evidence of any significant ingestion of radioactive materials was indicated by the analysis of these samples.

YAG monitoring survey results for the trip to the Zone of the Interior are summarized in Table 10.8.

TABLE 10.8 AVERAGE RADIATION LEVELS ABOARD TEST SHIPS DURING RETURN TO THE ZONE OF THE INTERIOR, NR/HR

	Departure PPG 5-25-54	Arrival Pearl Harbor 6-14-54	Departure Pearl Harbor	Arrival ZI 6-19-54
		YAG 39		
Average Topside Reading	8	4	4	4
Average Interior and Below Deck Reading	2	1	1	1
		YAG 40		
Average Topside Reading	44	19	19	17
Average Interior and Below Deck Reading	6	3	3	3

Radiation exposures of personnel on the return trip were predicted on the basis of the above readings, assuming one-third of the time was spent by ships' personnel in the above-deck area. These predictions, along with the actual dosages as determined by film badges are presented in Table 10.9.

The ratio of predicted dosage to the observed is in the neighborhood of 3 or 4.

The system of dosage control by general monitoring of working area, combined with daily badge reports, proved entirely feasible and effective.

TABLE 10.9 DOSAGE RECEIVED BY YAG PERSONNEL DURING RETURN TO THE ZONE OF THE INTERIOR, MR

	PFG to P. H.		P. H. to S. F.	
	Average Predicted	Average Film Record	Average Predicted	Average Film Record
YAG 39	800	258	480	214
YAG 40	3,600	1,114	1,900	304

tively prevented personnel from inadvertently exceeding maximum permissible exposure. The system of continuously monitoring during a decontamination operation afforded no better dosage control and had the added disadvantage of unduly using up the allotted dosage of monitoring personnel, the supply of which is critical to a program of this nature. The film badge, when properly worn, proved the most feasible and accurate device for measuring individual personnel exposures.

The zone system of contamination control was effective as long as personnel followed the established procedures for movement between zones. Changes of protective clothing effectively prevented personnel contamination. Close liaison by rad-safe personnel was helpful in insuring that contamination control procedures were followed and that the required protective clothing was worn.

10.3.3 Operations on Site Fred. Three separate operations of Project 6.4 were carried out on Site Fred: (1) aircraft decontamination studies; (2) panel decontamination studies; and (3) sample packaging for shipment to the ZI.

The radiological safety program for these operations were concerned with protective measures for personnel, collection of rad-safe data applicable to future field operations, and evaluation of rad-safe protective clothing and devices.

Aircraft, panels, and samples involved in the operations were off-loaded from the ships and brought to the island by water transportation. The aircraft and panel decontamination studies were carried out at the USAF Aircraft Decontamination Facility at the southern end of the island. The removal of YAG interior samples from their collector racks and packaging them for shipment was done in a small, open-side shelter in the center of the island.

A rad-safe center was established in a tent near the panel and aircraft decontamination area. At this center, protective equipment was issued and personnel were monitored. The rad-safe center on Site Elmer served as the home station and main supply center for all rad-safe operations. The center also served as the personnel decontamination station for all personnel, except in those cases where on-the-spot personnel decontamination measures were required. In such cases, the USAF Change House near the aircraft decontamination center was used.

The decontamination area was situated in such a way that prevailing winds carried steam and airborne particulate materials generated in the decontamination operations toward infrequently used areas and onto the lagoon. Liquid radioactive wastes generated during decontamination operations drained from the decontamination pad into the lagoon through an underground storm sewer. The sample packaging area was similarly located

so that prevailing winds carried particulates onto the lagoon. Solid radioactive wastes were disposed of by land burial in isolated areas.

Dosage control was accomplished by daily monitoring surveys of aircraft and panels in the decontamination operations (Table 10.10) and by checking radiation levels in work party zones. Problem leaders of both decontamination and sample packaging operations were kept advised of radiation exposure levels and of recommended dosage conservation measures. Self-reading pocket dosimeters were issued to selected members of work parties, and the readings obtained therein were used as corollary information in estimating dosage.

The film badge was the official measure of dosage received. The badge records of all personnel involved were studied each day by the rad-safe representative to determine daily dosage rates and to note which personnel were approaching their dosage limit. Project leaders were advised of all dosages which indicated undue individual exposures and corrective procedures recommended. Table 10.11 shows average daily exposures to personnel as indicated by film-badge records.

Contamination control was effected by roping off working areas, monitoring footwear of personnel leaving the contaminated area and changing footwear where necessary to prevent contamination spread to clean areas. Periodic wipe samples were taken of the exposed surfaces of panels, planes, and on samples to determine levels of removable contamination present. Air samples were taken during decontamination and sample packaging operations and respiratory protection was worn when indicated by sampling results. Table 10.10 summarizes air and wipe sampling results.

A stock of protective equipment was maintained in the decontamination area change station. Contaminated clothing was returned to the change house on Site Elmer and clean clothing was drawn, as necessary, to maintain the stock. Protective clothing was worn as required for the particular operation. For dry panel and aircraft operations and sample packaging operations, coveralls, shoes, canvas shoe covering, cotton gloves, and caps were generally found to be adequate. As actual decontamination of panel and aircraft surfaces was performed by wet chemical and physical methods, protective clothing for these operations included foul-weather gear, plastic coveralls, rubber boots, and plastic face shields.

Instrumentation for the Site Fred operations consisted of contamination detectors, dose rate meters, pocket dosimeters, film badges, and air samplers. All instrumentation was supplied from the Rad-Safe Center on Site Elmer.

It is recommended that in future operations of this nature, emphasis be given to advance planning for each day's operation. Information is required from the project leader about each day's operation so that the necessary protective equipment, dosimeters, and instrumentation can be made available for the operation.

Secondly, it is recommended that project leaders be made cognizant of the necessity of personnel under their direction following rad-safe rules and procedures.

Also, it is recommended that project leaders be impressed with the necessity of staying within their basic plan of operation. Major changes should be discussed with the rad-safe representative and a plan of action agreed upon.

TABLE 10.10 SUMMARY OF DAILY MONITORING SURVEYS

Date of Operation	Number of Personnel	Type of Operation	General Activity Levels		
			Average Radiation (mr/hr)	Average Removable Contamination (a/m/100 sq cm x 10 <sup>-3</sup> )	Air borne Activity (µc/cc x 10 <sup>-9</sup> )
Shot 1					
3-5-54	5	YAG 39 Aircraft Handling	2	-	-
		YAG 40 Aircraft Handling	3	53	-
3-6	6	YAG 40 Aircraft Decontamination	3	4	-
Shot 2					
3-30-54	6	YAG 39 Aircraft Decontamination	20	-	-
3-31	14	YAG 40 Aircraft Decontamination	2200	-	2.74
	8	Sample Packaging	370	-	1.46
4-1	8	YAG 40 Aircraft Decontamination	2800	-	17.8
4-2	25	YAG 40 Aircraft Decontamination	375	881	635 <sup>(a)</sup>
	4	Panel Decontamination	550	-	-
4-3	10	YAG 40 Aircraft Decontamination	370	73	35.2
4-4	16	YAG 40 Aircraft Decontamination	245	300	-
4-5	17	YAG 40 Aircraft Decontamination	180	-	0.80
4-6	9	YAG 40 Aircraft Decontamination	70	-	4.19
4-7	10	YAG 40 Aircraft Decontamination	65	560	1.85
	3	Panel Decontamination	160	-	-
4-8	8	Panel Decontamination	100	571	-
	6	YAG 40 Aircraft Decontamination	35	16	0.92
4-9	7	Panel Decontamination	160	-	-
Shot 4					
4-27	8	Off Loading Samples and YAG 39 Aircraft	200	-	-
4-28	6	YAG 39 Aircraft Decontamination	75	130	-
4-29	9	YAG 39 Aircraft Decontamination	35	-	-
4-30	10	YAG 39 Aircraft Decontamination	16	100	-
	6	Sample Packaging	10	50	1.11
	13	YAG 40 Aircraft Decontamination	175	-	-
	5	Panel Decontamination	100	-	-
Shot 4					
5-1-54	17	YAG 40 Aircraft Decontamination	150	1000	-
5-2	14	YAG 40 Aircraft Decontamination	60	16	-
	3	Panel Decontamination	60	-	-
Shot 5					
5-7	29	Off Loading Samples and YAG 39 and 40 Aircraft	450	-	-
5-8	9	YAG 40 Aircraft Decontamination	1100	14	9.50
	5	Sample Packaging	250	-	-
	9	YAG 39 Aircraft Decontamination	235	-	-
5-9	7	YAG 39 Aircraft Decontamination	140	-	-
	3	Panel Decontamination	470	-	-
	7	YAG 40 Aircraft Decontamination	460	-	-
5-11	17	YAG 40 Aircraft Decontamination	200	0.5	2.10
	5	Panel Decontamination	150	-	-
5-12	5	YAG 39 Aircraft Decontamination	40	-	-
	5	YAG 40 Aircraft Decontamination	150	3	-
5-13	6	YAG 40 Aircraft Decontamination	135	-	-
	3	Panel Decontamination	60	-	-
	3	Sample Packaging	60 <sup>(b)</sup>	-	-
5-15	2	Sample Packaging	14	0.5	-
5-17	-	Final Survey YAG 40 Aircraft from Shot 2	16	-	-
	-	Final Survey YAG 40 Aircraft from Shot 5	100	-	-
5-17	-	Final Survey YAG 39 Aircraft from Shot 2	3	-	-
	-	Final Survey YAG 39 Aircraft from Shot 5	40	-	-
6-18	4	Sample Packaging	10	5	-

(a) Sample taken in wet spray downwind from aircraft.

(b) General beta-gamma in immediate work area due to presence of contaminated objects.

TABLE 10.11 AVERAGE DOSAGES TO PERSONNEL DURING SITE FRIED OPERATION

Date	Daily Dosage (mr)	Date	Daily Dosage (mr)
30 Mar	126	29 Apr	21
31 Mar	1050	30 Apr	145
1 Apr	424	1 May	135
2 Apr	258	2 May	180
3 Apr	296	8 May	700
4 Apr	182	9 May	270
5 Apr	186	10 May	230
6 Apr	79	11 May	200
7 Apr	63	12 May	160
8 Apr	113	13 May	180
9 Apr	113	14 May	65
27 Apr	94	15 May	140
28 Apr	70	17 May	270

**10.3.4 Photodosimetry Operations.** The purpose of the photodosimetry program was: (1) evaluation of a film badge holder for field use; (2) evaluation of various interpretative procedures for film densities-dosage relationships; and (3) the correlation of dosage received with the type of work performed. A major objective of the program was gathering sufficient data concerning field dosimetry to adequately evaluate badge holders, film, issue systems, and interpretative procedures for future laboratory and field dosimetry operations.

A portion of the program attempted to evaluate a badge and an interpretative procedure that would give accurate results of exposures to the various types and energies of radiations without recourse to administrative procedures to obtain additional data on personnel movements. A system of processing badges was sought that would lend itself to the handling of the largest numbers of badges with the smallest number of dosimetry personnel.

The standard of comparison for the experimental film badge was the TU-7 badge which was used for official dosages reported for the entire scientific program. The TU-7 badge utilized the DuPont film packet No. 559, containing two films; the No. 502 emulsion, with a range from 40 mr to 10 r; and the No. 606 emulsion, with a range from 10 r to 400 r. The shield used on the film was a clip of  $\frac{1}{2}$ -mm lead; the film was sealed in a polyethylene bag against humidity and contamination.

The film-badge holder used by Project 6.4 was developed at LASL and consisted of two telescoping frames made of 0.02-in. brass. The badge is equipped with an open window and a 0.02-in. cadmium insert. The film used was the DuPont packet No. 552, with the No. 502 emulsion as in the TU-7 badge, and the No. 510 emulsion, with a range of 1 to 40 r. Each packet was sealed in polyethylene.

The processing procedures for the Project 6.4 and the TU-7 badges were identical. Insofar as possible, both badges were issued, worn, processed, and interpreted at the same times and under the same conditions.

The dosage determined by the TU-7 badge was for gamma only. The Project 6.4 badge was evaluated for beta and gamma dosages. The method of film interpretation for gamma dosage used was that outlined by Storm (Reference 21).

Estimates of beta dosages were made from the Project 6.4 badge by difference in net density between cadmium-shielded and open-window



portions and from a beta-calibration curve made from film exposed to natural uranium.

All dosage control was done on the basis of the exposure data from the TU-7 badges. These badges were processed and the dosages integrated into an operational total for each individual on a daily basis. From these totals, all decisions on the employment of personnel were made in accordance with the safety regulations formulated by the task force. The basic dosage allowance for the operation was 3.9 r. Certain personnel in special categories were granted additional dosage allowances upon submission of waiver requests.

Approximately 700 personnel were monitored by the Project 6.4 badge. In the dosimetry program, 5,250 badges were used, of which about 4,500 were used for personnel monitoring. Of these 4,500 badges, a representative sample of 1,125 TU-7 and Project 6.4 matched badge results have been drawn from a statistical treatment and a comparison made between the readings obtained from the two badges. The TU-7 badge data were used as basis of comparison with which to evaluate the Project 6.4 badge. A comparison of gamma dosages was made; it has been summarized in Table 10.12 by indicating the percentages of the various ratios of

TABLE 10.12 COMPARISON OF GAMMA DOSAGES

Interval of Ratio of Project 6.4 Data/TU-7 Data	Percent of Total Results
0.2	2.0
0.2 to 0.4	11.6
0.4 to 0.6	16.6
0.6 to 0.8	16.0
0.8 to 1.2	19.0
1.2 to 2	17.2
2 to 3	9.0
3 to 4	4.0
4 to 5	1.3
5 and over	3.3
	100.0

Project 6.4 badge reading to TU-7 badge readings.

The approximate gamma energy was determined from the difference in density under the brass and cadmium. From the gamma energies, correction factors were evolved to correct for the energy dependence of film to gamma in the extreme energy ranges.

These correction factors have been revised (Reference 22), particularly as they apply to the very-low and the very-high energies. A statistical study was made to determine the effect of the revised sets of correction factors upon the mass of data as determined during Operation Castle. It was found that, while a few results were changed quite considerably, the mass of data was not altered to any degree of statistical significance.

The exact significance of the data in Table 10.12 is not known. The table indicates that 19 percent of the time the dosages agreed within 20 percent of each other and that beyond this limit the Project 6.4 badge showed dosages lower than the TU-7 badge 46.2 percent of the time and higher dosages 34.8 percent of the time.

The fact that the two film badge determinations of personnel exposure

were greater than 20 percent apart 81 percent of the time would indicate that more work is required on this problem. Because of the large range in readings, a comparison with the use of ratios could be misleading. Thus, the dosage readings were plotted one against the other to show the relation of the values obtained with the two types of badge. If the two badges yield equivalent relative values of dosage, the above points should be along some definable pattern. Since this was not observed, the conclusion that additional study of the entire problem is required, was supported.

A study was also made of the dosages determined by the film badge in comparison with expected dosages estimated from levels and exposure times. A total of 338 pairs of badge readings and estimated dosages were used in the study. Comparison is made by observing the ratio of the expected readings to the badge reading. Table 10.13 is a summary of comparisons between expected and observed dosages taken from YAG decontaminations operations.

Table 10.13 shows that dosage estimates were off by more than a factor two 47 percent of the time. It is realized that there are many variables in connection with dosage determination. However, if the film badge is to serve as a true indicator of personnel exposure, it would seem important to establish a closer correlation between the dosages estimated

TABLE 10.13 COMPARISON OF EXPECTED AND OBSERVED DOSAGES FOR PROJECT 6.4 BADGES

Ratio of Expected Gamma Dosage to Badge Gamma Dosage	Observations	
	Number	Percent
0.2	4	1.2
0.2 to 0.4	28	8.3
0.4 to 0.6	30	8.9
0.6 to 0.8	27	8.0
0.8 to 1.2	54	16.0
1.2 to 1.4	21	6.2
1.4 to 1.6	21	6.2
1.6 to 1.8	15	4.4
1.8 to 2.0	11	3.2
2 to 3	52	15.4
3 to 4	32	9.5
4 to 5	18	5.3
5 and over	25	7.4
	338	100.0

from monitoring surveys and stay time and the dosages measured on film badges. It is interesting to note that Table 10.12 shows that the variation by more than a factor two occurred 31 percent of the time. True dosage determination becomes quite important when administrative procedures establish that an operational dosage limit is 3,900 mr and average daily exposures during certain phases of a field operation might be from 500 to 1,000 mr.

Approximately 5,000 dosage measurements have been recorded for 637 personnel. Of these, 19 have received dosages in excess of 7.8 r, 71 have received dosages between 7.8 and 3.9 r, and 547 have received dosages less than 3.9 r. The dosages, percentage-wise, are:

Dosage (r)	Personnel Exposed (%)
0 - 1	41.4
1 - 2	24.0
2 - 3	14.9
3 - 4	5.5
4 - 5	3.8
5 - 6	4.6
6 - 7	1.7
Over 7	4.1

Only one person received an excessive amount of radiation. One crew member coming aboard YAG 39 after Shot 5 inadvertently spent an excessive amount of time topside near several local hot spots. His dosage was determined to be about 20 r. Appropriate recommendations limiting future radiation exposure for this individual have been made.

A summary of total individual beta exposure is given in Table 10.14.

TABLE 10.14 ACCUMULATED INDIVIDUAL BETA EXPOSURES

Range (rep)	Personnel Exposed	
	Number	Percent
0 - 6.5	404	61.2
6.5 - 13	126	19.1
13 - 20	56	8.5
20 - 30	34	5.2
30 - 50	26	3.9
50	14	2.1
Total	660	100.0

A summary of individual wrist badge data and corresponding body dosages is given in Table 10.15.

The distribution of beta-to-gamma ratios as determined by film badges is shown in Table 10.16.

Film monitoring surveys were conducted through the months of April and May on Site Elmer. Twelve outdoor locations distributed over the island and nine locations on and around the rad-safe building were monitored continuously, in six increments. The results have been summarized in Tables 10.17 and 10.18.

The foregoing data and the general experience gained during Operation Castle indicated that the multiple-shield film-badge holder is adequate to meet the mass-production requirements of a field operation. The data collected indicates no obvious superiority over the single-shield badge in the area of gamma dosimetry. Unfortunately, there is no way to determine which badge gave the best estimate of the actual dosage received. The magnitude of possible beta exposure, as shown in Tables 10.14 through 10.16, indicate the desirability of recording beta dosages of personnel.

Some large discrepancies were noted in the comparison of the 6.4 and TU-7 badge results. These discrepancies may be explained in most part by the difference in film badge interpretation. The 6.4 badge interpretation attempted to evaluate an energy correction system currently under development. Field results indicated that additional work on this system was necessary. Some discrepancies may also be attributed to variations in wearing the two badges and to the response

TABLE 10.15 INDIVIDUAL WRIST-BODY BADGE DATA

Body Badge		Wrist Badge (Rt)		Wrist Badge (Left)	
(rep)	(r)	(rep)	(r)	(rep)	(r)
3.300	0.572	3.300	0.616	3.600	1.134
1.350	0.159	0.530	0.115	0.480	0.102
0.940	0.154	0.800	0.211	0.800	0.177
0.250	0.120	0.250	0.095	0.175	0.140
2.200	0.792	2.800	0.462	2.800	0.666
1.040	0.078	0.480	0.094	0.375	0.105
0.410	0.140	0.350	0.115	0.290	0.164
2.040	0.449	0.350	0.115	0.290	0.164
1.350	0.119	0.440	0.096	0.410	0.094
0.800	0.231	1.140	0.182	1.220	0.188
0.620	0.140	0.570	0.220	1.040	0.182
0.250	0.120	0.250	0.095	0.225	0.095
2.200	0.636	1.700	0.572	2.400	0.572
1.570	0.113	0.680	0.150	0.800	0.141
1.220	0.132	0.570	0.265	0.680	0.174
1.040	0.165	0.440	0.102	0.570	0.089
1.450	1.034	4.650	0.467	3.850	2.076
0.270	0.225	0.175	0.064	0.190	0.0
4.300	0.188	4.300	0.255	2.600	0.286
1.350	0.095	0.680	0.130	0.730	0.112
1.350	0.120	0.290	0.046	0.240	0.175
0.620	0.478	0.730	0.143	0.440	0.292
1.350	0.066	1.550	0.410	1.040	0.204
0.800	0.099	0.870	0.119	0.870	0.112
16.000	2.772	1.220	0.265	14.000	2.156
1.040	0.120	0.530	0.260	0.440	0.102
1.570	0.165	0.530	0.260	0.480	0.193
1.570	0.193	4.700	0.308	3.600	0.337
1.200	0.195	0.900	0.210	0.620	0.195
2.400	0.121	0.800	0.120	0.570	0.120
1.350	0.572	0.620	0.175	0.530	0.196
0.410	0.225	0.480	0.174	0.570	0.174
1.570	0.110	1.570	0.135	2.400	0.161
0.730	0.270	0.320	0.250	0.350	0.193
1.450	0.068	0.380	0.210	0.750	0.250
3.600	0.308	6.000	0.713	7.000	0.387
3.600	0.308	6.200	0.275	7.800	0.275
1.450	0.264	1.450	0.188	2.040	0.326
1.040	0.091	0.870	0.154	0.730	0.237
0.290	0.210	0.148	0.209	0.270	0.150
0.480	0.140	0.148	0.095	0.148	0.095
1.450	0.211	1.850	0.184	1.220	0.210
0.225	0.0	0.680	0.095	0.620	0.095
1.450	0.130	0.350	0.162	0.350	0.151
1.140	0.204	0.530	0.146	0.570	0.159
0.870	0.190	0.730	0.112	0.680	0.111
0.730	0.091	0.480	0.080	0.620	0.193
0.320	0.260	0.480	0.078	0.410	0.102
20.000	2.552	23.000	2.262	24.000	2.544
1.040	0.210	0.420	0.210	0.400	0.210
1.570	0.143	0.480	0.146	0.480	0.183
4.000	0.468	1.350	0.194	1.220	0.285
14.500	1.320	16.200	1.560	21.800	1.460
0.410	0.175	1.220	0.169	0.175	0.175
0.175	0.095	0.148	0.095	0.115	0.095
0.940	0.087	0.410	0.196	0.148	0.105
0.940	0.193	0.528	0.195	1.280	0.250
2.040	0.209	2.400	0.174	2.600	0.249
4.000	0.518	4.700	0.555	3.300	0.481
2.040	0.470	2.640	0.195	1.570	0.195
0.940	0.140	0.076	0.095	0.115	0.095
2.400	0.725	2.800	0.336	4.700	0.322
1.450	0.160	1.570	0.326	0.870	0.387
3.050	0.693	17.000	1.508	4.000	0.546
17.000	2.706	17.000	2.706	17.000	2.310
1.700	0.143	0.530	0.142	0.480	0.159
1.350	0.185	0.410	0.173	0.530	0.095
3.600	0.777	2.800	0.858	2.800	0.594
1.400	0.250	1.230	0.250	2.000	0.250
25.000	0.900	38.000	0.770	35.000	0.840

TABLE 10.15 INDIVIDUAL WRIST-BODY BADGE DATA (CONTINUED)

Body Badge		Wrist Badge (Rt)		Wrist Badge (Left)	
(rep)	(r)	(rep)	(r)	(rep)	(r)
1.350	0.167	0.570	0.175	0.530	0.175
0.730	0.071	0.620	0.095	0.570	0.146
0.620	0.260	0.800	0.166	0.870	0.299
0.620	0.182	1.350	0.110	0.800	0.188
0.940	0.135	0.190	0.140	0.190	0.150
17.000	1.040	16.000	1.125	18.000	2.294
29.000	2.332	24.000	1.584	25.000	1.320
1.510	0.077	0.750	0.250	1.070	0.250
2.500	0.960	12.000	3.306	9.500	2.750
6.500	0.314	64.000	1.200	64.000	1.200
1.040	0.228	0.190	0.291	0.530	0.120
3.050	0.495	3.600	0.732	4.300	0.545
0.0	0.064	0.076	0.0	0.115	0.064
35.000	1.040	42.000	1.850	20.000	1.250
0.350	0.0	0.350	0.095	0.350	0.095
5.100	0.375	49.000	2.040	20.000	1.624
2.400	0.145	2.400	0.202	1.850	0.246
25.000	1.064	3.970	1.443	4.270	0.854
1.040	0.118	0.350	0.210	0.440	0.175
0.410	0.448	19.000	1.040	30.000	1.000
1.700	0.590	2.200	0.224	2.200	0.290
4.000	0.362	0.730	0.381	1.570	0.290
1.450	0.225	1.040	0.264	1.570	0.290
0.350	0.215	1.140	0.108	0.730	0.108
0.320	0.175	0.290	0.141	0.250	0.095
0.870	0.175	0.530	0.207	0.620	0.111
1.700	0.080	2.040	0.312	2.400	0.276

of the film badge to a mixed radiation field.

From the standpoint of ease of issue, collection, and processing, the clip-on shield, prenumbering-prepackaging features of the TU-7 badge proved to best meet the requirements of a field badge.

The use of the probit system<sup>1</sup> and of correction factors in evaluating gamma dosage may have increased the accuracy of interpretation somewhat, but the additional time required to introduce those factors is not justified in a field situation.

For future operations, it is recommended that a film packet be utilized with the following features: (1) two film packets with high and low-range films; (2) prenumbered packets presealed in waterproof coverings; (3) a single clip-on gamma shield and a single clip-on beta shield made of plastic material; and (4) a metal eyelet so that the badge can be worn on a chain hung around the neck.

It is recommended that interpretation procedures be designed to obtain film data quickly after use of the film on many individuals and to produce these data with a relatively small number of dosimetry personnel. Interpretation should be compatible with basic accuracy of the film; no attempt should be made to attain the precision expected for scientific research. A record system can be set up that will enable a small number of dosimetry personnel to maintain dosage control records for large numbers of personnel.

To simplify dosage-control procedures during field operations, it

<sup>1</sup> The probit system (Reference 23) is a method for plotting film calibration curves. In this method densities are plotted versus log exposures, obtaining straight-line relationships. Ordinarily, densities are plotted versus exposures, resulting in a curve which is inaccurate at its extremities.

TABLE 10.16 BETA-TO-GAMMA DOSE RATIO FROM FILM-BADGE DATA

$\beta/\gamma$ Ratio	Distribution	
	No. of Dosages	Percent of Total
1	16	2.7
1 - 2	89	13.5
2 - 3	100	15.2
3 - 4	106	16.1
4 - 5	85	12.9
5 - 6	74	11.2
6 - 7	44	6.7
7 - 8	23	3.5
8 - 9	23	3.5
9 - 10	27	4.1
10 - 11	13	2.0
11 - 12	12	1.8
12 - 13	6	0.9
13 - 14	9	1.4
14 - 15	7	1.1
15 - 20	11	1.7
20 - 30	5	0.8
30	6	0.9
TOTAL	658	100.0

is recommended that more continuity be given to records of personnel exposure. For example, if a control record system could be established for documenting the radiation exposure of all personnel participating in field operations, it should be possible to use an increased time scale

TABLE 10.17 ENVIRONMENTAL MONITORING, SITE ELMER

Dates Covered	Average Gamma (mr/day)	Average Beta (mrep/day)	$\beta/\gamma$ Ratio
4-6-54 to 4-10-54	64	313	4.9
4-10 to 4-17	47	210	4.5
4-17 to 4-24	26	173	6.7
4-24 to 5-1	21	195	9.3
5-1 to 5-8	22	141	6.4
5-8 to 5-15	25	-	-

for establishing the upper limit for field-operation radiation exposure. Instead of using the current 13 weeks-3.9 r value, it is recommended that the annual 15 r figure be used. The system would work as follows: A card would be made out for each individual indicating the amount of radiation exposure received during the past calendar year. An entry would be made, indicating the amount of dosage expected to be used at the person's home station during the current year. The difference between

TABLE 10.18 ENVIRONMENTAL MONITORING, RAD-SAFE CENTER

Dates Covered	Average Gamma (mr/day)	Average Beta (mrep/day)	$\beta/\gamma$ Ratio
4-1 to 4-8-54	52	124	2.4
4-8 to 4-14	46	85	1.8
4-14 to 4-24	71	53	0.7
4-24 to 5-1	28	57	2.0
5-1 to 5-8	46	76	1.7
5-11 to 5-19	28	80	2.9

the total of these two values and 30 r would be the maximum amount of dosage available for use during the current field operation. For example, an individual received 8 r during the preceeding calendar year and expected to receive 5 r at his home station for the balance of the current year. Therefore,  $30 - (8 + 5) = 17$  r would be the maximum allowable exposure of that individual. This does not mean that an exposure of 17 r is encouraged or even recommended. Radiation exposure should be kept to a minimum at all times. However, this does mean that if that individual received 17 r he would be immediately removed from the possibility of receiving any additional radiation exposure.

Such a system makes dosage control an automatic system and eliminates the need for waivers. It is also a more realistic approach, since it requires a more complete dosage record be maintained than is currently established. In addition, this system prevents any individual from knowingly receiving more than 30 r during any two calendar year periods, which is the current recommendation of the AEC, the International Committee on Radiation Protection, BuMed and Surgery, and others.

10.3.5 Support Facilities. The Change House facilities that were available on Site Elmer were used jointly by Project 6.4 and the TU-7 Rad-Safe Unit. Subordinate facilities were employed on the field and consisted of dress-out and check stations on board ships and on Site Fred. The Elmer center was equipped with showers, head, dressing and contaminated-clothing-removal rooms, clothing-storage-and-issue rooms, a counting room, an instrument-storage-and-repair room, photo-dosimetry-processing spaces, and office spaces.

The protective equipment furnished by Project 6.4 was added to the existing TU-7 stocks, and an issue system from the combined stocks was established. A chit issue and control system was set up wherein information was noted daily as to quantities issued of clothing and film badges. Table 10.19 is a summary of the quantities issued each day of the operation. This table is a fair index of the levels of work activity during the operation.

The items issued were determined by the problem leaders on the basis of the radiological conditions, the type of work to be carried out, and recommendations from Rad-Safe personnel. Problem leaders assumed the responsibility for items issued to the various teams. A daily shelf inventory was initiated wherein shortages in supply could be anticipated. When feasible, clothing issue was made the day prior to an operation by Change House personnel using a list of names and sizes to assemble complete sets of protective clothing. This system facilitated the processing of personnel through the Change House.

Existing facilities (such as the shower, clothing-change spaces, clothing-storage-and-issue room, and the clothing-collection-and-laundering system) that had been set up by TU-7 were used wherever possible. A tent was set up as a station for monitoring and contaminated-clothing removal.

A system was established whereby all personnel returning from operational work received a person-and-clothing monitoring survey at the entrance to the Change Tent. Following this survey, all clothing was removed and placed in separate containers for each item of apparel. An attempt was made to keep noncontaminated items separate for reuse without laundering. The guide-lines used were a meter reading of 10 mr/hr, open-window, for clothing and 10 mr/hr, closed-window, for shoes.

TABLE 10.19 QUANTITIES OF PROTECTIVE EQUIPMENT ISSUED

Date	No. of Persons Badged	Shoes, leather	Socks, cotton	Overshoes, rubber	Booties, canvas	Gloves, rubber; acid resistant	Gloves, leather and cotton	Underwear	Trousers and Shirts, cotton	Overalls, cotton	Suits, plastic	Caps	Face Shields, plastic	Gas Masks MK5 and MK9A1
2-9 Mar	75	49	40	22	176	60	193	31	7	87	31	25	24	6MK5
10 Mar	-	-	8	-	-	-	4	2	7	-	-	-	-	12MK9-3MK9
28 Mar	41	2	-	-	3	-	3	-	-	3	-	3	-	-
29 Mar	59	9	11	4	26	-	34	-	1	29	-	19	-	-
30 Mar	28	54	13	8	32	-	47	11	-	75	-	65	-	4MK5
31 Mar	279	84	71	2	127	-	286	32	25	123	-	130	-	-
1 Apr	201	43	46	1	43	11	102	45	1	55	12	75	-	-
2 Apr	96	22	25	-	82	-	87	31	-	56	-	85	-	-
3 Apr	167	49	74	1	30	-	147	47	1	34	12	94	18	-
4 Apr	86	32	81	21	99	31	100	70	8	102	-	47	8	-
5 Apr	119	37	93	-	124	26	113	57	13	149	31	124	7	-
6 Apr	132	46	69	-	51	3	54	38	7	61	-	28	-	-
7 Apr	64	21	30	-	54	-	57	20	7	63	6	12	-	-
8 Apr	90	14	12	20	20	-	28	7	12	38	-	2	-	-
9 Apr	127	67	100	3	129	15	190	63	10	147	-	39	-	-
10 Apr	105	38	23	3	-	3	96	38	5	41	-	-	-	-
11 Apr	36	5	6	-	3	-	61	5	6	5	-	-	-	-
12 Apr	275	57	119	38	126	12	221	83	21	172	2	78	-	8MK5
13 Apr	52	34	30	9	35	5	45	18	5	37	4	18	-	4MK9
27 Apr	95	37	47	2	84	-	96	36	-	55	-	-	-	-
28 Apr	43	36	37	-	37	-	50	37	1	37	-	37	-	-
29 Apr	71	7	74	-	34	-	53	39	-	30	-	-	-	-
1 May	59	5	7	2	10	-	14	3	-	11	-	3	-	-
6 May	66	26	29	-	49	-	51	3	-	30	-	47	-	-
8 May	236	32	33	1	47	3	58	32	-	35	-	35	-	-
9 May	88	5	42	13	60	13	98	41	-	79	12	82	-	-
10 May	95	8	10	2	14	-	20	5	-	18	-	-	6	-
11 May	161	8	10	-	29	-	35	-	-	13	-	8	-	-
12 May	78	5	6	-	12	-	50	5	-	25	-	10	-	-
13 May	90	118	7	-	11	-	46	4	-	7	-	3	-	-
15 May	132	15	101	15	-	1	101	50	-	101	-	50	-	-
16 May	51	8	19	4	14	-	32	15	-	47	-	38	-	-
17 May	131	32	33	3	16	-	55	4	3	98	30	62	-	-
18 May	94	30	47	-	16	-	44	41	-	108	-	28	-	-
19 May	71	28	26	1	-	-	11	50	-	97	-	31	-	-
20 May	56	14	24	-	-	-	2	23	-	100	-	24	-	-
21 May	80	9	16	2	2	-	12	-	2	25	-	5	-	-

From the clothing-removal tent, all personnel passed through the shower. Complete body-monitoring surveys were then made of all personnel and special measures were taken to remove any remaining skin contamination. Permissible level for skin contamination was a meter reading of 1 mr/hr, open-window. Usually showering or hand washing with soap removed all detectable skin contamination. Certain stubborn cases required special treatment such as: (1) corn-meal abrasive in addition to powdered detergent; (2) citric acid; (3) trisodium phosphate; and (4) grease-removal creams.

All dosimeters were collected at the clothing-removal tent for processing.

The major portion of personnel and clothing contamination occurred after Shots 2 and 5. During decontamination and recovery operations, the clothing of as many as 60 percent of the Project 6.4 personnel and ship's crew became contaminated. Clothing contamination varied from 40 to 500 mr/hr. In some instances, glove and bootie contamination was as high as 30 r/hr. Approximately 25 cases in which personnel had excessive body contamination were noted. All cases were successfully decontaminated; no serious contamination accidents occurred during the Project 6.4 operation.



Decontamination of clothing was carried out in a separate laundry operated by civilian contractor personnel under the guidance of the Task Force Rad-Safe organization. Clothing for laundering was segregated according to the degree of contamination. Items reading up to 200 mr/hr were sent for immediate laundering. Items contaminated to higher levels were held in an isolated storage area for decay to the above level before laundering.

Operation of the Change Station had been proposed as a joint effort of the Project 6.4 and TU-7 Rad-Safe organization. With the exception of maintenance of laundering services and removal of certain clothing stocks, the bulk of the task was handled by the Project 6.4 organization. With the limited numbers of personnel assigned, it was not possible to operate the station at the required peak of efficiency. In particular, during rush periods of clothing issue for personnel embarking on an operation and processing returning personnel, the operations were slowed as a result of the shortage of Change House personnel.

Shortages developed in the supply of certain protective clothing items. The most serious shortages were in cotton gloves, socks, underwear, and certain shoe sizes. It was found that cotton gloves, in many cases, were nonusable after one laundering, due to excessive shrinkage. Socks and underclothing disappeared through pilferage. Shoes became short in supply through pilferage and through large numbers being tied up in storage for decay of contamination.

In spite of the above difficulties, the overall mission of the Change House was accomplished. All personnel engaging in operational work were provided adequate protective equipment, and the monitoring and decontamination of returning personnel proved satisfactory in preventing injury to personnel and controlling the spread of contamination.

It is recommended that in future operations pre-operational planning consider a more realistic number of personnel to be available for change-house operation. Personnel and space commitments for change-house operation from outside organizations should be very firm and without need for further interpretation in the field.

The protective equipment requirements for an operation should be estimated with generous allowances for contingencies. If clothing is to be supplied from outside sources, a clear understanding should be reached as to the quantities available.

A careful clothing control system is indicated for personnel returning from work in contaminated areas to minimize losses. A chit system for controlling the return of clothing is too cumbersome to be effective, but a very-rigid flow system for personnel may be successful.

10.3.6 Air Sampling. The prime objective of the air-sampling program was collecting information about airborne activity encountered during the decontamination phase of the Project 6.4 operation. The following operations were carried out to collect the data for assessing the hazards encountered: (1) air sampling for shipboard and decontamination operations; (2) fallout air sampling; (3) particle-size determinations, and (4) gamma-background monitoring.

The program on the test ships revealed no air concentrations greater than of the order of  $10^{-7}$   $\mu\text{c}/\text{cc}$ , either above or below decks during all decontamination operations, except for very local conditions caused by operation of the Tennant machine. Consequently, respiratory

protection was not required, except for the Tennant machine operations. Tables 10.20 through 10.22 give results of air samples taken on the YAG 39 and YAG 40 and on Site Fred during normal work and during decontamination operations.

Concentration samples were taken of fallout activity, both on board ship and on Site Elmer. The shipboard samples were given an immediate check with a beta-ionization chamber and later counted in the Elmer counting facility. Table 10.23 lists fallout activities obtained. All counting results are corrected for decay. The beta-ionization-chamber readings showed fairly good correlation with the results of laboratory counting. Only one fallout air sample indicated activity levels above the allowable limit of  $10^{-6}$   $\mu\text{c}/\text{cc}$ , and that only for a short period of time.

TABLE 10.20 AIR SAMPLING DATA, YAG 39 OPERATIONS

Date	Location	Activity ( $\mu\text{c}/\text{cc}$ )
3-3-54	Topside, main deck	$1.4 \times 10^{-9}$
3-3	Topside, main deck	$5.2 \times 10^{-10}$
3-4	Topside, main deck	$1.7 \times 10^{-10}$
3-4	Topside, main deck	$1.7 \times 10^{-10}$
3-4	Topside, main deck	$9.4 \times 10^{-10}$
3-4	Topside, main deck	$8.6 \times 10^{-10}$
3-4	Topside, main deck	$1.0 \times 10^{-9}$
3-4	Topside, main deck	$5.0 \times 10^{-9}$
3-28	Stateroom No. 4	$1.4 \times 10^{-9}$
3-28	Topside, main deck	$3.5 \times 10^{-9}$
3-28	Hold, No. 4	$1.1 \times 10^{-9}$
3-28	Radioroom	$9.0 \times 10^{-10}$
3-29	Crew's Quarters	$2.6 \times 10^{-9}$
3-29	Crew's Quarters	$3.5 \times 10^{-9}$
3-29	Crew's Quarters	$1.6 \times 10^{-9}$
4-2	Flying Bridge	$9.7 \times 10^{-9}$
4-2	Topside, No. 3 Cubicle	$2.3 \times 10^{-9}$
4-2	Topside, No. 3 Cubicle	$3.2 \times 10^{-9}$
4-2	Topside, No. 2 Hold	$2.3 \times 10^{-9}$
4-2	Topside, No. 2 Hold	$1.5 \times 10^{-9}$
4-5	Topside, Aft Deck House	$1.1 \times 10^{-8}$
4-6	Topside, Boat Deck	$3.4 \times 10^{-9}$
4-7	Topside, Midship area	$5.1 \times 10^{-9}$
4-9	Topside, No. 1 King Post	$1.2 \times 10^{-9}$
4-9	Flying Bridge	$1.4 \times 10^{-9}$
5-11	Topside, No. 5 Hold	$1.2 \times 10^{-8}$
5-11	Topside, Amidships	$6.2 \times 10^{-10}$
5-16	Topside, 01 Deck	$1.7 \times 10^{-9}$
5-17	Topside, Boat Deck	$3.0 \times 10^{-9}$
5-17	Topside, Boat Deck	$7.0 \times 10^{-8}$
5-17	Topside, Fantail	$8.0 \times 10^{-10}$
5-17	Topside, Boat Deck	$1.0 \times 10^{-9}$
5-17	Topside, Boat Deck	$1.3 \times 10^{-9}$
5-18	Topside, Boat Deck	$2.5 \times 10^{-9}$
5-18	Topside, Boat Deck	$1.8 \times 10^{-9}$

In connection with particle-size studies, cascade impactors were operated during conditions of fallout on board ship and on Site Elmer. This device gave a rough approximation of the specific activity of the various sizes of particles in the air stream from 0.5 through 8.9 microns by virtue fractionation on five stages. The determination is made by measuring the beta activity of aerosol particles on the slides. At the 17.5 liter/min flow rate of the cascade impactor, a several-hour sample was required in order to buildup enough fractionated particles to obtain a significant count and subsequent determination of the median particle

TABLE 10.21 AIR SAMPLING DATA, YAG 40 OPERATIONS

Date	Location	Activity ( $\mu\text{c}/\text{cc}$ )
3-3-54	Boiler Room	$1 \times 10^{-11}$
3-3	Boiler Room	$1.4 \times 10^{-10}$
3-3	Boiler Room	$7.9 \times 10^{-11}$
3-3	Boiler Room	$3.5 \times 10^{-11}$
3-3	Boiler Room	$9.7 \times 10^{-11}$
3-30	Engine Room	$1.6 \times 10^{-7}$
3-30	No. 4 Hold	$8.8 \times 10^{-8}$
3-30	Engine Room	$1.2 \times 10^{-7}$
3-30	Engine Room	$4.2 \times 10^{-8}$
3-30	No. 4 Hold	$1.7 \times 10^{-8}$
4-4	No. 3 Hold	$2.6 \times 10^{-8}$
4-4	No. 3 Hold	$4.5 \times 10^{-8}$
4-6	Engine Room	$9.0 \times 10^{-11}$
4-6	Engine Room	$2.2 \times 10^{-9}$
4-6	No. 4 Hold	$9.0 \times 10^{-11}$
4-6	No. 3 Cubicle	$3.8 \times 10^{-8}$
4-7	Engine Room	$2.5 \times 10^{-10}$
4-7	Top Aft Deck House	$2.3 \times 10^{-9}$
4-8	Engine Room	$4.0 \times 10^{-9}$
4-8	Engine Room	$3.6 \times 10^{-9}$
4-9	Topside, No. 1 Kingpost	$6.0 \times 10^{-10}$
4-12	Flight Deck	$8.9 \times 10^{-10}$
4-12	Topside, 01 Deck	$1.1 \times 10^{-9}$
4-12	Topside, 01 Deck	$2.5 \times 10^{-8}$
4-12	Topside, 01 Deck	$8.6 \times 10^{-9}$
4-12	Topside, 01 Deck	$1.1 \times 10^{-9}$
4-12	Flight Deck	$1.2 \times 10^{-10}$
4-12	Topside, 01 Deck	$2.4 \times 10^{-10}$
4-12	Topside, 01 Deck	$3.0 \times 10^{-9}$
4-12	Topside, 01 Deck	$1.6 \times 10^{-10}$
4-12	Topside, 01 Deck	$1.3 \times 10^{-9}$
4-13	Topside, No. 4 Hold	$5.9 \times 10^{-9}$
4-13	Tennant Machine Opns.	$8.0 \times 10^{-9}$
5-17	Topside, No. 3 Hold	$3.5 \times 10^{-8}$
5-17	Topside, No. 3 Hold	$9.8 \times 10^{-9}$
5-18	Topside, No. 5 Hold	$3.1 \times 10^{-9}$
5-18	Topside, No. 5 Hold	$2.3 \times 10^{-9}$
5-21	Topside, Boat Deck	$3.4 \times 10^{-9}$
5-21	Topside, Boat Deck	$2.3 \times 10^{-9}$
5-21	Topside, Boat Deck	$4.9 \times 10^{-9}$
5-21	Topside, Boat Deck	$4.3 \times 10^{-8}$
5-21	Topside, Boat Deck	$1.1 \times 10^{-8}$

size. From a consideration of the air-jet velocity in each stage and by the use of assumption that aerosol fission products will be attached to NaCl nuclei (particle density, 2.16 g/a) from the shot, Table 10.24 has been prepared showing the relationship of particle size to the jet stage.

Table 10.25 is a summary of the particle-size information gained from cascade impactor air sampling.

A background gamma monitoring station was set up in the Change House on Site Elmer to gain information concerning fallout gamma background and its relation to air concentrations of fallout activity. Figures 10.1 and 10.2 show the time-activity relationship for fallout airborne and gamma activity for Shot 2. It is seen that the airborne-activity record gives a clearer picture of the incidence and departure of the fallout cloud than the gamma record and should be of greater value in determining the incidence of successive fallout when the gamma background situation is higher than normal.

From the airborne-gamma-activity data for fallout contamination a rough, order-of-magnitude relationship between airborne activity and rate of gamma buildup was derived. Table 10.26 shows the airborne activities to be expected from various rates of gamma buildup.

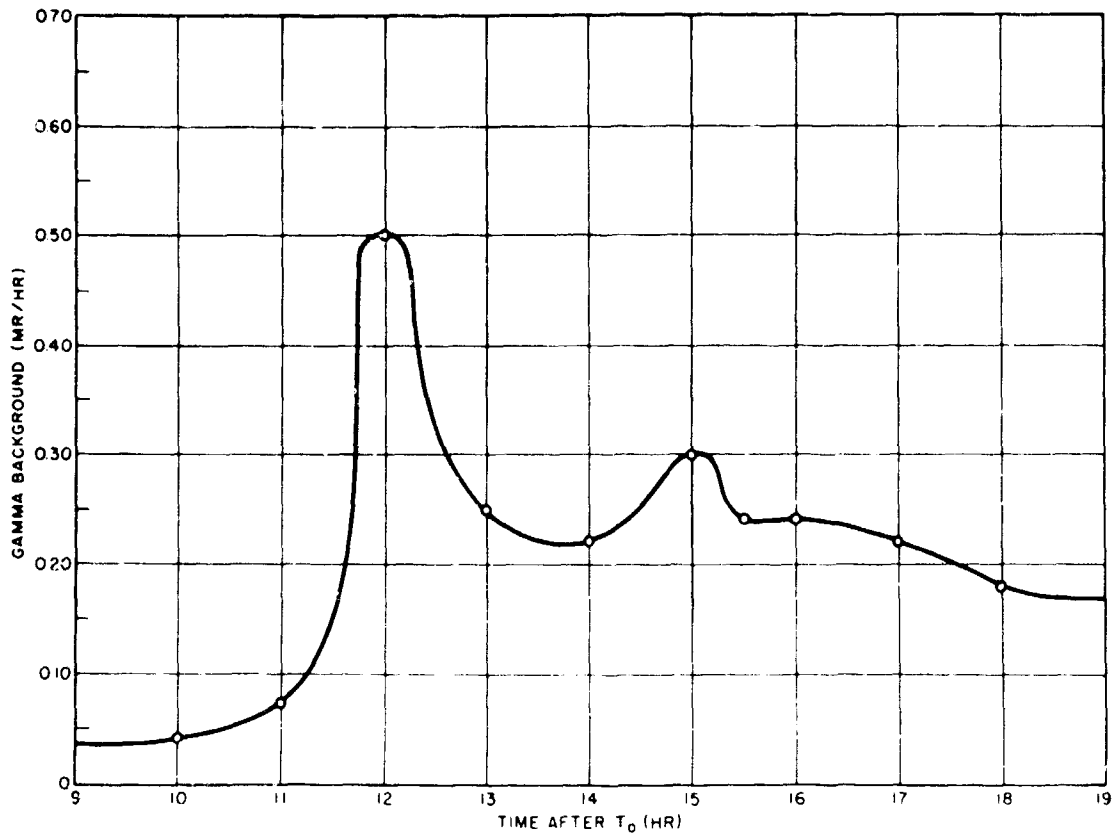

Figure 10.1 Gamma background record of fallout on Site Elmer following Shot 2.

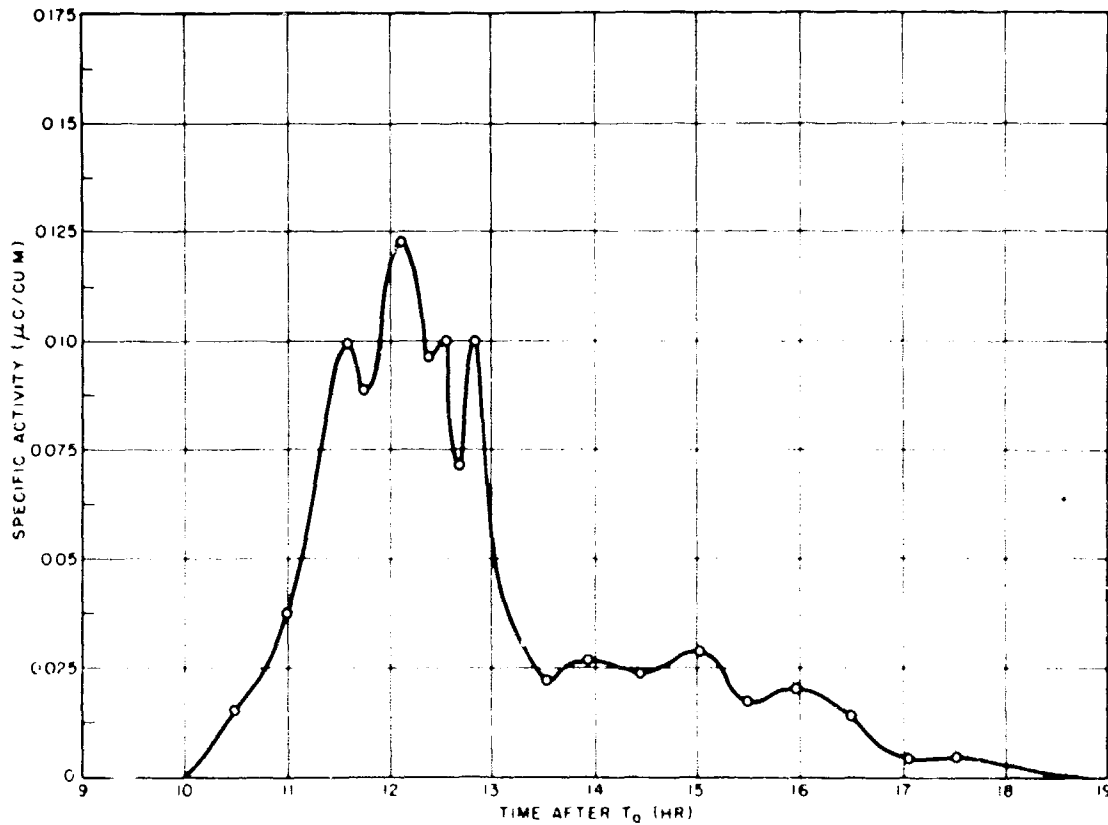

Figure 10.2 Specific activity record of fallout on Site Elmer following Shot 2.

TABLE 10.22 AIR SAMPLING DATA, SITE FRIED OPERATIONS

Date	Location	Activity ( $\mu\text{c}/\text{cc}$ )
3-31-54	Aircraft Decontamination Area	$2.7 \times 10^{-9}$
3-31	Sample Packaging Area	$1.8 \times 10^{-9}$
3-31	Sample Packaging Area	$1.1 \times 10^{-9}$
3-31	Sample Packaging Area	$2.3 \times 10^{-9}$
3-31	Sample Packaging Area	$9.0 \times 10^{-10}$
3-31	Sample Packaging Area	$1.6 \times 10^{-9}$
3-31	Sample Packaging Area	$1.8 \times 10^{-9}$
3-31	Sample Packaging Area	$8.0 \times 10^{-10}$
4-1	Aircraft Decontamination Area	$2.4 \times 10^{-8}$
4-1	Aircraft Decontamination Area	$1.2 \times 10^{-8}$
4-3	Aircraft Decontamination Area	$7.0 \times 10^{-8}$
4-3	Aircraft Decontamination Area	$9.8 \times 10^{-10}$
4-5	Aircraft Decontamination Area	$7.9 \times 10^{-10}$
4-6	Aircraft Decontamination Area	$4.1 \times 10^{-9}$
4-6	Aircraft Decontamination Area	$4.2 \times 10^{-9}$
4-7	Aircraft Decontamination Area	$8.9 \times 10^{-10}$
4-7	Aircraft Decontamination Area	$5.8 \times 10^{-9}$
4-7	Aircraft Decontamination Area	$3.5 \times 10^{-9}$
4-7	Aircraft Decontamination Area	$3.5 \times 10^{-9}$
4-8	Aircraft Decontamination Area	$7.1 \times 10^{-10}$
4-8	Aircraft Decontamination Area	$1.0 \times 10^{-9}$
4-30	Aircraft Decontamination Area	$1.7 \times 10^{-9}$
4-30	Aircraft Decontamination Area	$4.5 \times 10^{-10}$
5-8	Aircraft Decontamination Area	$5.0 \times 10^{-10}$
5-10	Aircraft Decontamination Area	$3.1 \times 10^{-9}$
5-10	Aircraft Decontamination Area	$1.2 \times 10^{-8}$
5-11	Aircraft Decontamination Area	$2.1 \times 10^{-9}$

It is of interest to consider if measurable amounts of fission product are excreted in the urine as a function of levels of airborne activity. Available data, from samples submitted by personnel from the Belle Grove, indicate that no detectable urine contamination resulted from exposure to airborne concentrations of the order of  $10^{-6}$   $\mu\text{c}/\text{cc}$ . These samples were collected 4 to 10 days after exposure and assayed 25 to 30 days after collection. Table 10.27 shows above-deck gamma-background levels measured on the Belle Grove (LSD2) at the 33-mi circle on 1 March 1954 and their relation to the airborne concentrations as derived from Table 10.26.

The practical consideration of the allowable limits of airborne specific activity should be approached from the allowable integrated dose for an operation. The permissible concentration for a 40-hr-week working year is  $10^{-9}$   $\mu\text{c}/\text{cc}$  for unknown radioactive material, but the decay factor of fission product contamination allows a working figure at one day of  $10^{-6}$   $\mu\text{c}/\text{cc}$ .

Air samples are taken for the purpose of determining the average concentration of airborne activity in a working area. Respiratory equipment is cumbersome and reduces efficiency of the worker; current airborne-activity information is necessary to determine whether such respiratory equipment is necessary.

Gamma background monitoring is a useful way, when combined with an air-sampling program, of determining the incidence of fallout. An order-of-magnitude figure for airborne activity can be obtained by measuring the rate of build up of gamma activity from fallout contamination.

TABLE 10.23 AIR SAMPLING DATA, FALLOUT ACTIVITY

Date	Location	Counting Results Corrected to Sampling Time ( $\mu\text{c}/\text{cc}$ )	Time
Shot 1			
3-1	ATF 106	$5 \times 10^{-9}$	0800
3-1	ATF 106	$5 \times 10^{-9}$	0930
3-1	ATF 106	$5 \times 10^{-9}$	1100
3-1	ATF 106	$1 \times 10^{-9}$	1445
3-1	ATF 106	$7.5 \times 10^{-7}$	1550
3-1	ATF 106	$8.6 \times 10^{-7}$	1620
3-1	ATF 106 (Interior)	$8.6 \times 10^{-8}$	1700
3-1	ATF 106	$6.7 \times 10^{-7}$	1740
3-1	ATF 106 (Interior)	$4.0 \times 10^{-7}$	1935
3-1	ATF 106	$5.3 \times 10^{-7}$	2000
3-2	ATF 106 (Interior)	$1.4 \times 10^{-7}$	0820
3-2	ATF 106	$9.0 \times 10^{-8}$	0930
3-2	ATF 106	$8.3 \times 10^{-8}$	1300
3-2	ATF 106	$6.2 \times 10^{-8}$	1630
3-1	ATF 114	$6.5 \times 10^{-8}$	1600
3-1	ATF 114	$5.0 \times 10^{-7}$	1630
3-1	ATF 114	$3.5 \times 10^{-7}$	1830
3-1	ATF 114	$4.6 \times 10^{-7}$	1900
3-1	ATF 114	$5.4 \times 10^{-7}$	2030
3-2	ATF 114	$1.2 \times 10^{-7}$	0830
3-3	Elmer	$3.2 \times 10^{-9}$	1030
3-3	Elmer	$3.3 \times 10^{-9}$	1145
Shot 2			
3-3	Elmer	$1.7 \times 10^{-9}$	-
3-3	Elmer	$1.3 \times 10^{-9}$	-
3-3	Elmer	$1.5 \times 10^{-9}$	-
3-3	Elmer	$2.7 \times 10^{-10}$	-
3-3	Elmer	$7.7 \times 10^{-10}$	-
3-3	Elmer	$7.2 \times 10^{-10}$	-
3-27	ATF 106	$1 \times 10^{-9}$	0710
3-27	ATF 106	$1 \times 10^{-9}$	1000
3-27	ATF 106	$1 \times 10^{-9}$	1130
3-27	ATF 106	$1 \times 10^{-9}$	2230
3-28	ATF 106	$1.5 \times 10^{-9}$	1300
3-28	ATF 106	$1 \times 10^{-9}$	1600
3-31	ATF 106	$2.7 \times 10^{-10}$	1030
3-27	Elmer	$1 \times 10^{-10}$	0830
3-27	Elmer	$1 \times 10^{-10}$	1030
3-27	Elmer	$1 \times 10^{-10}$	1230
3-27	Elmer	$1 \times 10^{-10}$	1430
3-27	Elmer	$3.5 \times 10^{-8}$	1850
3-27	Elmer	$3.5 \times 10^{-8}$	1920
3-27	Elmer	$3.2 \times 10^{-8}$	1940
Shot 2			
3-27	Elmer	$2.5 \times 10^{-9}$	2200
3-28	Elmer	$1.3 \times 10^{-9}$	0900
3-28	Elmer	$1.3 \times 10^{-9}$	0945
3-28	Elmer	$1.0 \times 10^{-9}$	1020
3-28	Elmer	$5.4 \times 10^{-10}$	1400
3-28	Elmer	$5.4 \times 10^{-10}$	1440
3-28	Elmer	$5.4 \times 10^{-10}$	1515
3-29	Elmer	$7.7 \times 10^{-10}$	0930
3-29	Elmer	$8.3 \times 10^{-9}$	0700
3-29	Elmer	$1.1 \times 10^{-8}$	0800
3-29	Elmer	$1.8 \times 10^{-9}$	0900
3-29	Elmer	$4.2 \times 10^{-9}$	1000
3-29	Elmer	$3.1 \times 10^{-9}$	1100
3-29	Elmer	$9.0 \times 10^{-9}$	1515
3-30	Elmer	$1.5 \times 10^{-9}$	1645
3-31	Elmer	$4.4 \times 10^{-9}$	1500
3-31	Elmer	$3.3 \times 10^{-9}$	1530
3-31	Elmer	$1.0 \times 10^{-8}$	1600
3-31	Elmer	$5.0 \times 10^{-9}$	1630
4-1	Elmer	$6.0 \times 10^{-10}$	0915
4-1	Elmer	$3.6 \times 10^{-10}$	0945
Shot 4			
4-26	ATF 106	$2.0 \times 10^{-10}$	1000
4-26	ATF 106	$4.4 \times 10^{-8}$	1715
4-26	ATF 106	$3.1 \times 10^{-7}$	1800
4-26	ATF 106	$1.1 \times 10^{-7}$	1930

TABLE 10.23 AIR SAMPLING DATA, FALLOUT ACTIVITY (CONTINUED)

Date	Location	Counting Results Corrected to Sampling Time (uc/cc)	Time
4-26	ATF 106	$8.3 \times 10^{-7}$	1945
4-26	ATF 106	$4.2 \times 10^{-7}$	2000
4-26	ATF 106	$1.0 \times 10^{-6}$	2015
4-26	ATF 106	$2.1 \times 10^{-7}$	2050
4-27	ATF 106	$1.7 \times 10^{-8}$	0745
4-27	ATF 106	$1.6 \times 10^{-8}$	1318
4-27	Elmer	$2.3 \times 10^{-9}$	0845
4-27	Elmer	$2.1 \times 10^{-9}$	1030
4-27	Elmer	$8.9 \times 10^{-10}$	1425
Shot 5			
5-5	ATF 106	$1 \times 10^{-10}$	0730
5-5	ATF 106	$3.0 \times 10^{-8}$	1800
5-6	ATF 106	$3.8 \times 10^{-10}$	1100
5-5	Elmer	$2.6 \times 10^{-9}$	2000
Shot 6			
5-14	Elmer	$1.3 \times 10^{-10}$	0720
5-14	Elmer	$2.1 \times 10^{-10}$	0930
5-14	Elmer	$4.5 \times 10^{-10}$	1030
5-14	Elmer	$1.3 \times 10^{-8}$	1900
5-14	Elmer	$1.7 \times 10^{-8}$	1925
5-14	Elmer	$1.0 \times 10^{-8}$	2045
5-14	Elmer	$8.9 \times 10^{-8}$	2145

It is recommended that a sliding scale be adopted for allowable airborne concentrations for field operations. It is recommended that respiratory protection be worn only when the concentrations tabulated in Table 10.28 are exceeded for the exposure periods included. This table indicates higher airborne maximum permissible concentrations at earlier times after the formation of the fission products. These are

TABLE 10.24 RELATION OF PARTICLE SIZE AND JET STAGE

Jet Stage	Air Velocity (meter/sec)	Median Particle Size (microns)
5	Filter stage(unknown)	0.53
4	77	0.8
3	27.5	1.65
2	10.2	3.72
1	2.2	8.9

relative to the standard maximum permissible concentration of  $1 \times 10^{-9}$  uc/cc for long-lived (one month or more half-life) fission products as the ratio of their effective half-lives.

Air-sampling equipment capable of taking and measuring a sample in one operation in the field should be developed and used. Such equipment would enable immediate decisions to be made regarding the need for respiratory equipment.

It is recommended that the gathering of information on fallout particle size be continued in future field operations and that studies be made to relate body retention with particle sizes of airborne particulates.

A continuous gamma monitoring station equipped with a suitable alarm system should be a requisite for working and living in areas in the vicinity of possible fallout conditions during field tests.

TABLE 10.25 SUMMARY OF THE PARTICLE SIZE INFORMATION GAINED FROM CASCADE IMPACTOR AIR SAMPLING

Date	Time after Shot (hr)	Location	Median Particle Size (microns)
Shot 2			
3-27-54	12	Elmer	1.0
3-28	25	Elmer	1.7
3-29	60	Elmer	0.75
3-30	72	Elmer	5.0
3-30	82	Elmer	4.2
Shot 3			
4-8	29	Elmer	1.8
Shot 4			
4-26	13	ATF 106	1.4
4-27	34	ATF 106	2.7
Shot 5			
5-5	10	Parry	1.3
5-6	26	Parry	1.0
Shot 6			
5-14	16	Parry	0.53

10.3.7 Instrumentation. All rad-safe instrument requirements for Project 6.4 operations were supplied and maintained by the rad-safe group. Three main types of portable monitoring instruments were used in the program. For clothing and personnel monitoring a "contamination meter," the side window, GM PDR/5 or NRDL MK-III, Model I, was used; for radiation measurements of gamma fields, a "dose-rate meter," the PDR/T1B; for beta-gamma measurements, a second type of dose-rate meter, the IM5/PD or "Cutie Pie" was used.

A small supply of AN/PDR-18A's were available for measuring high-radiation fields but were not used, due to the medium-range dose rates encountered in the operation.

A continuous-recording air monitor, consisting of a moving filter tape moving past a beta probe, and a continuous-recording gamma monitor, consisting of a shielded halogen-filled GM tube driving a counting rate meter and recorder were provided to obtain a record of a fallout contamination on Parry.

A 6-C Co<sup>60</sup> source, the Navy UDM-1, was set up complete with track to obtain daily calibration checks on all gamma monitoring instruments.

TABLE 10.26 AIRBORNE ACTIVITIES EXPECTED FROM DIFFERENT RATES OF GAMMA BUILDUP BASED ON OBSERVED DATA, SITE ELMER

Rate of Gamma Buildup (mr/hr/hr)	Airborne Activity (uc/cc)
50	$1 \times 10^{-6}$
5	$1 \times 10^{-7}$
0.5	$1 \times 10^{-8}$
0.05	$1 \times 10^{-9}$



TABLE 10.27 ABOVE-DECK GAMMA-BACKGROUND LEVELS AND AIRBORNE CONCENTRATIONS FROM THE BELLE GROVE

Time	Radiation Level (mr/hr)	Air borne Concentration ( $\mu\text{c}/\text{cc}$ )
0000	0.5	$5 \times 10^{-8}$
1300	8.0	$5 \times 10^{-7}$
1400	25.0	$1 \times 10^{-6}$
1900	180.0	

Two types of air samples are utilized, each for a different purpose. Concentration samplers utilizing filter paper to collect the particles from the air stream were used to obtain the total concentration of particulate matter in the air. Both 110-v AC and 24-v dc samplers were used. All samplers were calibrated with the filter paper in place. The nominal flow rates of the 110-v AC samplers were 20 cu m/hr and that of the 24-v dc samplers were 7 cu m/hr. Each air sampler was equipped with an ionization chamber, which gave a continuous indication of the activity of the sample as it was being collected. The ionization chamber was capable of detecting 0.1  $\mu\text{c}$  amounts of activity deposited on the paper in a background not exceeding 300 mr/hr. With this device, air concentrations of the order of  $10^{-8}$   $\mu\text{c}/\text{cc}$  can be measured in a 30-min sampling period.

The other type of air sampler employed was the particle-size analyzer, which was used to determine the sizes of the airborne particulates. The Cassella-type cascade impactor, driven by a standard air pump, was used for this purpose. As described in the air-sampling portion of this report, an approximation was made of the specific activity of the various sized fractions of particles in the air stream from 0.5 through 8.9 microns. The various-sized particles were separated by virtue of fractionation from various-sized jets impinging on glass slides. The actual determination is made by counting the beta activity of aerosol particles on the slides.

For laboratory analysis of air and wipe samples, a gas-flow proportional counter was used. Although background-gamma radiation from local fallout contamination often ran 10,000 c/m, satisfactory measurements could be made in most cases of the field samples. The laboratory counters were given daily calibration checks with a  $\text{Sr}^{90}$ -impregnated filter and a  $\text{Tl}^{204}$ -impregnated filter of the same physical dimension as the unknown samples. These standards were prepared prior to the operation

TABLE 10.28 RECOMMENDED ALLOWABLE AIRBORNE CONCENTRATIONS

Days after Detonation	Concentration $\mu\text{c}/\text{cc}$ of Air	Total Period Period of Exposure
0.1	$2.7 \times 10^{-5}$	1 day
1	$1.7 \times 10^{-7}$	1 day
2	$1.2 \times 10^{-7}$	1 day
4	$9.9 \times 10^{-8}$	1 day
7	$7.9 \times 10^{-8}$	1 day
14 to 28	$1.0 \times 10^{-8}$	2 weeks

by measured quantities of standardized solutions of these radioisotopes to standard-sized filter papers and fixing in place with a plastic spray.

The instrumentation used on the field operation proved adequate for the purpose intended, but certain features could be improved.

The side-window (as opposed to the end-window GM) was found to be the only instrument suitable for clothing and personnel monitoring. The calibration of these instruments were in milliroentgens per hour which proved to be quite meaningless as far as personnel contamination was concerned. Relative scale readings were used to define allowable contamination levels.

The AN/PDR-T1B instrument proved to be quite satisfactory for the gamma-dose-rate measurements made during the operation. Comparison of this instrument with the AN/PDR-18A showed agreement within the limits of reading accuracy in a radiation field. The AN/PDR-18A was also quite satisfactory for general gamma monitoring, although the lower limit of sensitivity was of the order of 50 mr/hr.

The IM5/PD, or Cutie Pie, which was used for beta measurement, was found to be somewhat unreliable under the humid conditions encountered in the field. The malfunction rate was found to be excessive.

Of the side-window GM instruments, the MK III, Model I proved to be more convenient in operation, more compact, and had a better probe arrangement than the AN/PDR-5. The two instruments were about equal in reliability, both requiring an excessive amount of maintenance due to the humid climate.

The air samplers performed satisfactorily under the conditions encountered. The ionization chamber feature proved to be useful in obtaining on-the-spot data concerning airborne contaminations.

#### 10.4 CONCLUSIONS AND RECOMMENDATIONS

It was determined that it should be feasible to estimate the average radiation level aboard a contaminated ship on the basis of dose-rate measurements taken from another nearby vessel, such as a recovery ATF or some similar ship capable of making some type of monitoring pass. The procedure outlined in Appendix H gave a reasonable order-of-magnitude determination in three separate trials during Operation Castle. However, it will always be necessary for any boarding party to conduct monitoring surveys, particularly to locate any "hot spots."

It is recommended that, in future field operations, emphasis be given to indoctrination of personnel in the use and wearing of protective clothing, the procedures to be followed in movement between contaminated and noncontaminated zones, and the wearing and care of the film badge. Protective-clothing requirements should be kept to the minimum consistent with adequate protection. Emphasis should be given to advance planning for each day's operation. The rad-safe organization requires such notification so that the necessary protective equipment, dosimeters and dose-rate instrumentation can be made available. Major changes to operational plans should be discussed with a rad-safe representative and a plan of action agreed upon. It is important that project leaders establish the necessity for those personnel under their supervision to follow rad-safe rules and procedures.

Photodosimetry-interpretation procedures should produce prompt results with a minimum expenditure of manpower. In addition to gamma dosages, it is recommended that beta dosages also be measured with special attention given to exposure to body extremities under special situations. For future field operations, it is recommended that a film packet be utilized with the following features: (1) two film packets with high- and low-range films; (2) prenumbered packets presealed in waterproof coverings; (3) a single clip-on gamma shield and a single clip-on beta shield made of a plastic material; and (4) a metal eyelet so that the badge can be worn on a chain hung around the neck.

It is recommended that consideration be given to increasing the time scale used for establishing allowable dosages for field operation. By establishing a central record system that would maintain continuity of radiation exposure received by personnel during all field operations, it is felt that the exposure unit of 15 r per year could be used. The allowable dosage for any individual would be determined by the amount of radiation exposure received during the past calendar year and the amount of exposure expected during the current calendar year. The difference between the total of these two values and 30 r would be the maximum amount of dosage available for use at the present field operation.

In spite of minor operational difficulties, the overall mission of the Personnel Decontamination Center was accomplished. All personnel engaging in operational work were provided adequate protective equipment, and the monitoring and decontamination of returning personnel proved satisfactory in preventing injury to personnel and controlling the spread of contamination. It is recommended that in future operations more consideration be given to the number of personnel required for the effective operation of a change house. The protective equipment requirements for an operation should be estimated with generous allowances for contingencies. A careful clothing-control system is indicated for personnel returning from work in contaminated areas to minimize losses. A chit system for controlling the return of clothing is too cumbersome to be effective, but a rigid flow system for personnel may be successful.

It is recommended that a sliding-scale Table 10.28 be adopted for allowable airborne concentrations for personnel exposure during field operations.

Air-sampling equipment capable of taking and measuring a sample in one operation in the field should be developed and used. Such equipment would enable immediate decisions to be made regarding the need for respiratory equipment. It is recommended that the gathering of information of fallout particle size be continued and that studies be made to relate body retention with particle sizes of airborne particulates.

A continuous gamma monitoring station equipped with a suitable alarm system should be a requisite for working and living areas in the vicinity of possible fallout conditions during field tests.

The following instrumentation is recommended as that which would provide the most satisfactory service for future field operations: (1) high range gamma dose rate - AN/PDR-T1B, AN/PDR-18A; (2) median range gamma dose rate - AN/PDR-T1B; (3) median range beta-gamma dose rate - field Cutie Pie type with calibrated beta dose rate meter indication; (4) contamination meter - log-indicating-meter portable GM with 0-100,000 c/m in 3 cycles; and (5) air sampling equipment - (a) 110-v AC

motor blower unit equipped with an ionization and bucking chamber;  
(b) continuous indexing with 4 cycle log meter indication in c/m starting at 100 c/m. Median flow rate (10-20 cfm).

On the basis of past experience and observation of radiological safety in field operations, it is recommended that consideration be given to establishing the radiological safety function for field operations on a continuing basis. This would provide a collection center for appropriate records (such as radiation exposure of personnel), enable protective equipment and instruments to be stock piled, and provide continuity to the rad-safe program such that the benefits from past experience and the lessons learned from previous mistakes would result in a constant improvement in field radiological safety. Such a unit could provide the basis for realistic indoctrination and training of civilian and military personnel in the field of radiological defense. It would serve as the basis for testing and improving various rad-safe procedures, such as contaminated-area monitoring and delineation, film-badge issue and processing, personnel-decontamination-center operation and procedures, evaluation of dose-rate instrumentation, contamination meters, air samplers, and other special rad-safe equipment. The merit of such a system seems many-fold and should make a real contribution to national security through the training and indoctrination of civilian and military personnel in the fundamental principles of radiological safety.

## Appendix A

# SUPPLEMENTARY MATERIAL ON WASHDOWN COUNTERMEASURES

### A.1 RATIO OF CONTAMINATION EFFECTS FOR THE TWO SHIPS, ASSUMING NO WASHDOWN OCCURRED.

In determining the ratio of contamination effects for the two ships, assuming that no washdown had occurred, use was made of the following definitions:

- X = gamma dose rate at the shielded masthead station.
- Y = gamma dose rate at the unshielded deck station near the kingpost.
- A = gamma dose rate contributed by contaminants in the air at any unshielded exterior station.
- D = gamma dose rate contributed by contaminants on the dome of an unshielded station on the kingpost.
- M = gamma dose rate contributed by contaminants on the masthead to an unshielded station on the kingpost.
- k = attenuation factor due to lead shielding.
- h = ratio of the gamma dose rate at masthead height to that one meter above the deck resulting from deck surface contaminants.
- f = unshielded fraction of D contributing to X.
- g = unshielded fraction of M contributing to X.
- Q = ratio of contamination effects of YAG 39/YAG 40 that would have been observed if YAG 39 had had no washdown.

Q is a measure of the deviation from the assumption that the two ships would have shown the same contamination effects if the protected ship had had no washdown. The actual measurements of gamma fields observed on the two ships must be adjusted for this difference in contamination effects to produce realistic values of washdown effectiveness.

The shielded masthead station reading results from the following contributions:

1. Contaminants on the masthead station dome, some of which are shielded from the masthead station detectors;
2. Contaminants on the masthead surfaces, all of which are shielded from the masthead station detectors;
3. Contaminants on the deck station dome and on the deck surfaces, all of which are shielded from the masthead station detectors;
4. Contaminants in the air surrounding the masthead station, some of which are shielded from the masthead station detectors.

Symbolically this may be written as:

$$X = [f + (1-f)k]D + kM + kh(Y - A) + [g + (1-g)k]A \quad (A.1)$$

For Shot 5, it seems reasonable to assume that the contributions of the contaminated air, masthead station dome, and masthead surfaces to the masthead station readings on the two ships were proportional to the general contamination which would have resulted if neither ship had been washed, that is:

$$\frac{D_a}{D_b} = \frac{M_a}{M_b} = \frac{A_a}{A_b} = Q \quad (\text{A.2})$$

where the subscripts a and b refer to YAG 39 and YAG 40, respectively. Since the deck surfaces were affected by the washdown it follows that:

$$Y_a \neq QY_b, \quad \text{therefore}$$

$$\frac{X_a - khY_a}{X_b - khY_b} = \frac{[f + (1-f)k]D_a + kM_a + [g + (1-g)k - kh]A_a}{[f + (1-f)k]D_b + kM_b + [g + (1-g)k - kh]A_b} \quad (\text{A.3})$$

Substituting the relationships of A.2 into A.3 results in

$$\frac{X_a - khY_a}{X_b - khY_b} = Q \quad (\text{A.4})$$

This ratio was evaluated both for cumulative-dose and dose-rate comparisons. For the dose comparison the dose values up to a given time were substituted for the dose-rate values indicated in the equation.

The values of k were calculated from the data of the absorption studies.

Approximate values of h were obtained from Figures D.2c and D.2d in Appendix D of the Effects of Atomic Weapons handbook. A gamma energy of 1 Mev was assumed for this estimation because the effect of choice of gamma energy appeared to influence the estimate of h only to a minor degree in the energy region of interest.

Example. Shot 5 at 4 hr after burst.

For a finite contaminated slab having an equivalent radius of 13 meters and a masthead approximately 10 meters above the deck, the value of h was estimated to be 0.2. The value of k was approximately 0.15,  $X_a = 21$  r/hr,  $X_b = 13.2$  r/hr,  $Y_a = 8.3$  r/hr, and  $Y_b = 65$  r/hr.

$$\therefore Q = \frac{21 - 0.03 \times 8.3}{13.2 - 0.03 \times 65} = 1.84 \text{ for dose-rate comparison at 4 hr}$$

For the dose comparison, accumulated dose up to 4 hr were substituted into the equation.

For Shot 4, the techniques used for Shot 5 in evaluating Q cannot be applied, because the masthead stations on YAG 39 were inadvertently washed, whereas those on YAG 40 were not. In this case  $D_a/D_b \neq Q$  and to obtain a variable which is not affected by differences due to washing action, it is necessary to use:

$$\frac{X_a - khY_a - [f + (1-f)k]D_a}{X_b - khY_b - [f + (1-f)k]D_b} = Q \quad (A.5)$$

However, the values of  $f$  and  $D$  cannot be evaluated from existing data, and relatively small errors in estimating these values have a large effect on the value of  $Q$ . Several rough estimates of  $f$  and  $D$  gave values of  $Q$  both larger and smaller than unity, which probably indicates that the safest assumption to make is that equal contamination effects occurred on the two ships.

Qualitative study of the masthead station data shows: (1) similar times of fluctuation of dose rates, which indicates similar periods of fallout on the two ships; (2) similar rates of buildup of dose rates when corrected for decay and plotted on linear scales, which would tend to indicate similar rates of buildup of contamination levels, at least during the early periods; and (3) the reduction of the dose rate by rain on the unwashed kingpost station dome at 5.5 hr (see Figure 2.9) which would be expected to be less than that by a continuous dome washdown leads one to conclude that reasonably good agreement between the shielded station data from the two ships would have resulted had both domes been continuously washed. All these qualitative considerations indicate that the assumption of equal contamination effects on the two ships should give fair estimates of washdown effectiveness.

## A.2 FLOW RATE AND WIND SPEED GRAPHS

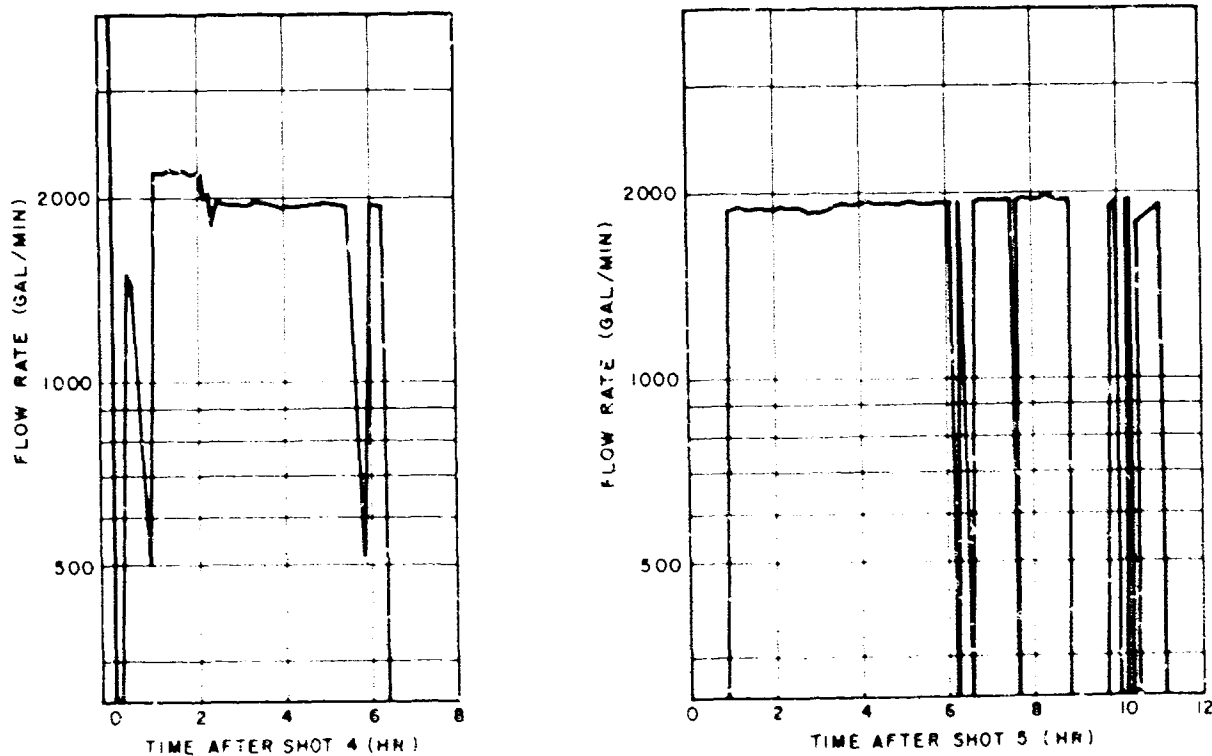

Figure A.1 Washdown supply flow rate aboard the YAG 39 versus time after Shots 4 and 5.

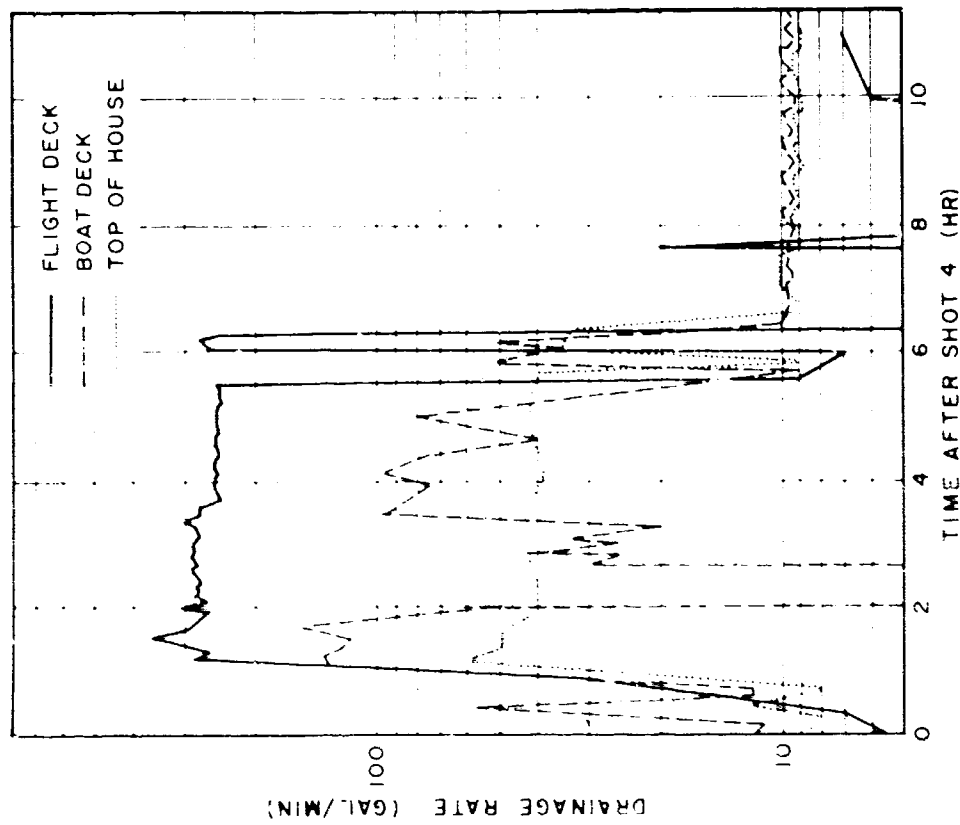
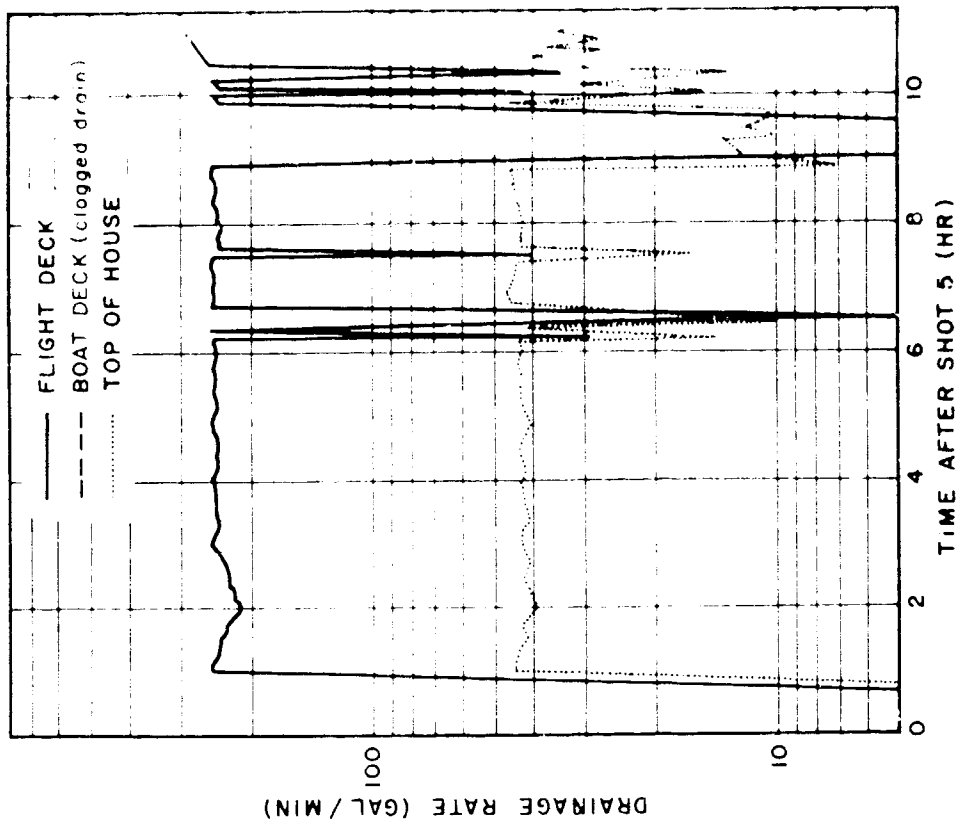

Figure A.2 Drainage flow rates from various areas of YAG 39 versus time after Shots 4 and 5.



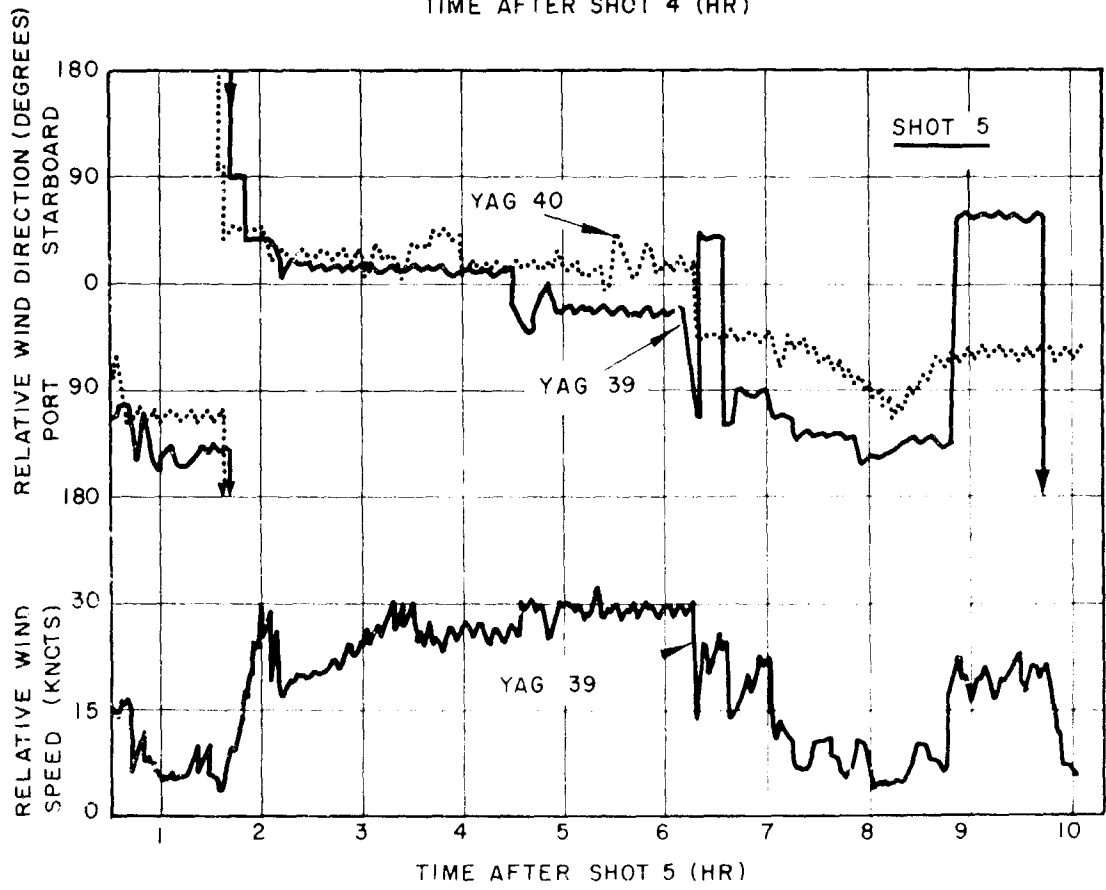
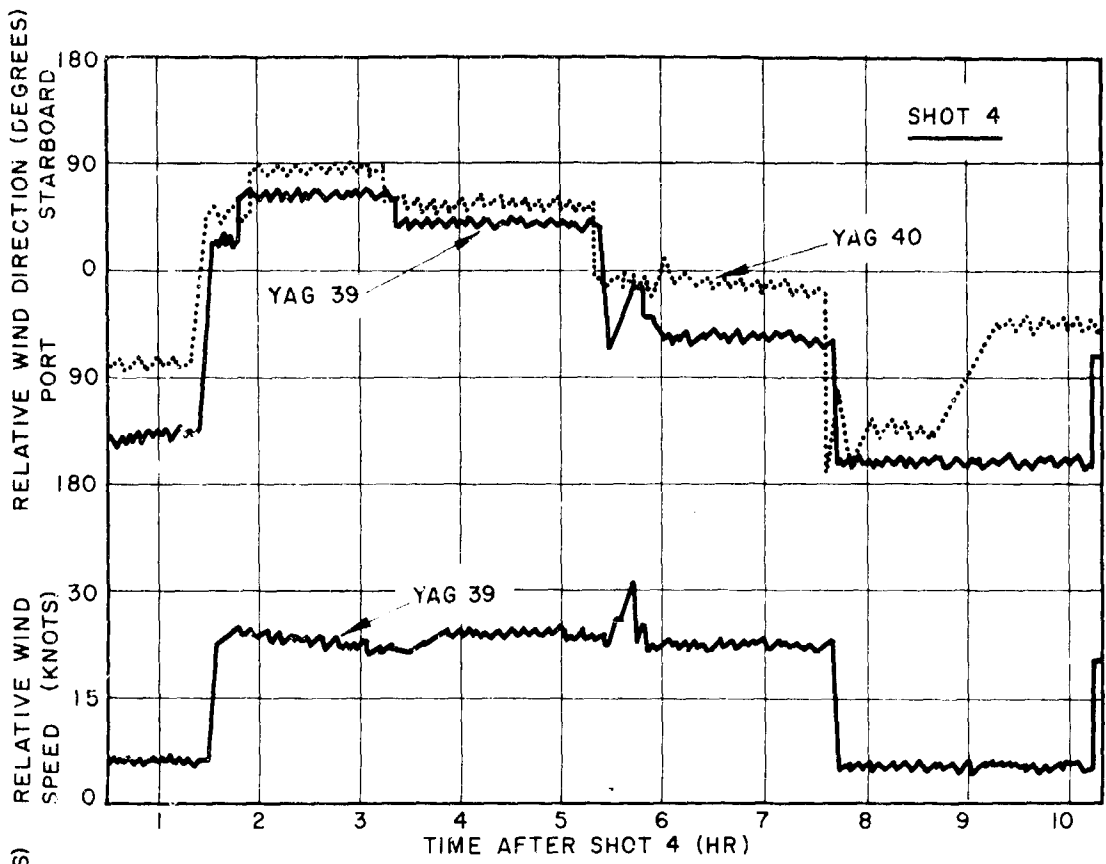

Figure A.3 Relative wind speed and direction aboard YAG 39 and 40 versus time after Shots 4 and 5.

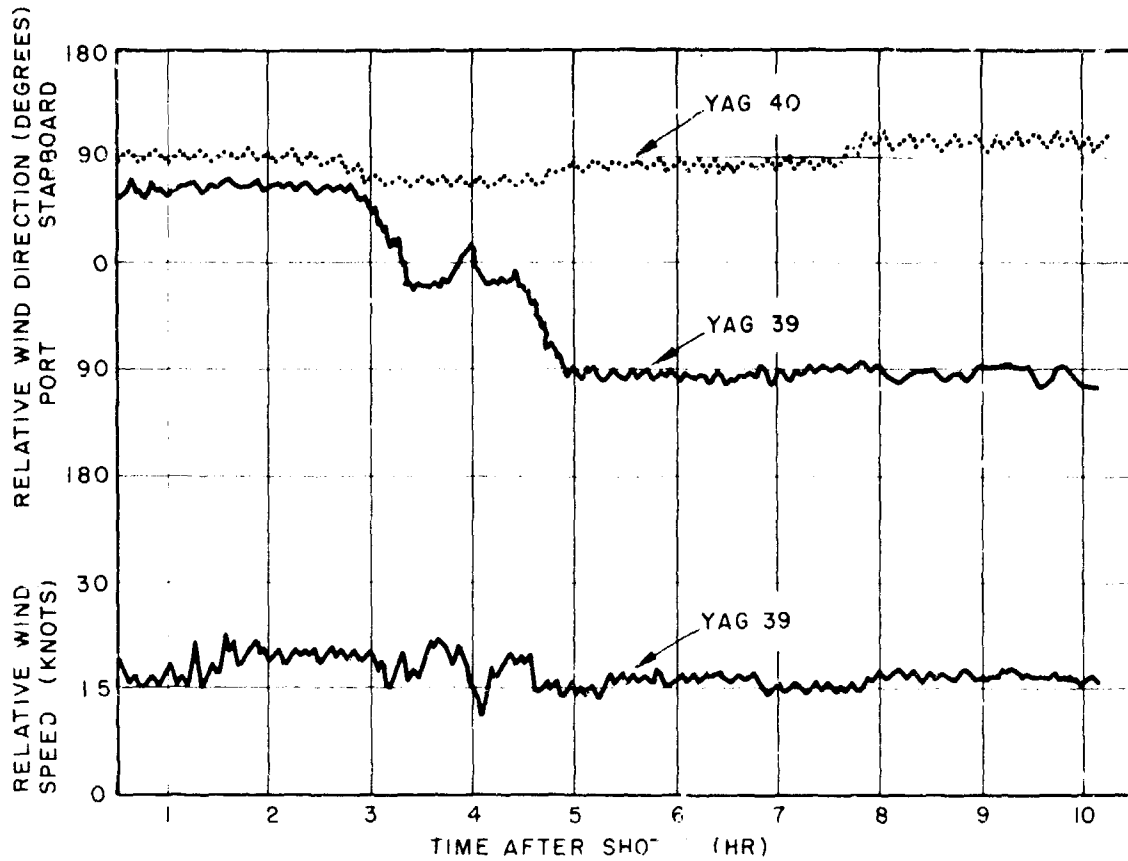

Figure A.4 Relative wind speed and direction aboard YAG 39 and YAG 40 versus time after Shot 2

A.3 TABULATED DATA

TABLE A.1 CUMULATIVE GAMMA DOSE (r) FOR DETECTOR STATIONS IN EXTERIOR AREAS AT VARIOUS TIMES AFTER SHOT 4

YAG 39												
Station Time (hr)	Flight Deck				Boat Deck				Top of House <sup>(b)</sup>			
	1s <sup>(a)</sup>	2s	3p	Av.	4s	4p	61s	62p	Av.	45s	46p	Av.
1.5	0.47	0.57	0.82	0.63	-	0.33	0.44		0.39	0.29	0.5	0.40
2.0	1.7	1.55	2.04	1.76	-	1.13	1.3		1.22	0.73	0.9	0.82
2.5	2.3	2.34	3.05	2.56	2.5	1.7	1.95		2.05	1.14	1.13	1.16
3.0	2.7	2.87	3.69	3.09	3.45	2.2	2.45		2.7	1.41	1.34	1.38
3.5	3.0	3.3	4.07	3.46	4.1	2.65	2.82		3.19	1.6	1.49	1.55
4.0	3.25	3.6	4.45	3.77	4.6	2.8	3.12		3.51	1.7	1.59	1.65
4.5	3.45	3.8	4.7	3.98	4.9	2.85	3.35		3.70	1.8	1.68	1.74
5.0	3.6	4.0	5.0	4.2	5.15	2.93	3.5		3.86	1.89	1.76	1.83
								NO DATA				
YAG 40												
1.5	3.0	3.1	5.0	4.3	1.75	3.15	1.7	2.55	2.29	1.85	2.55	2.2
2.0	9.6	33.0	26.5	23.2	7.0	8.8	8.7	9.6	8.52	6.1	7.25	6.68
2.5	17.0	37.0	50.0	31.5	15.0	14.3	16.0	17.4	15.7	9.7	12.0	10.85
3.0	23.5	76.0	70.0	56.5	22.5	19.1	22.5	24.2	22.1	12.6	15.0	14.2
3.5	29.0	95.0	86.0	69.0	28.7	23.7	28.0	30.0	27.3	15.0	19.0	17.0
4.0	33.5	104.0	94.9	77.5	34.0	25.9	32.5	35.0	31.9	16.6	21.7	19.2
4.5	38.0	113.0	108.0	86.3	36.5	28.5	36.0	39.0	35.5	18.0	23.9	22.0
5.0	41.5	120.0	122.0	94.5	42.0	30.5	39.0	42.0	38.4	19.0	25.5	23.25

(a) s, p, and c indicate that the station is starboard, port, or on ship's centerline.

(b) Stations 4' and 4'' are partially shielded.

TABLE A.2 CUMULATIVE GAMMA DOSE (r) FOR DETECTOR STATIONS ON MAIN DECK AT VARIOUS TIMES AFTER SHOT 4

YAG 39															
Station Time (hr)	Main Deck Forward										Main Deck Aft				
	11s(a)	12p	13s	14p	16c	29s	30p	31s	32p	Av.	65s	67s	68p	71c	Av.
1.5	0.34	0.4	0.26	0.5	0.31	0.37	0.54	0.39	0.41	0.39	0.68	0.47	0.98	0.7	0.71
2.0	1.0	1.16	0.98	1.45	1.25	1.17	1.66	1.2	1.45	1.26	1.9	2.39	2.9	1.75	2.24
2.5	1.62	1.76	1.73	2.37	2.05	1.85	2.6	2.1	2.3	2.04	3.05	3.9	4.2	3.0	3.54
3.0	2.1	2.2	2.34	3.0	2.65	2.45	3.3	2.95	2.9	2.66	3.9	5.2	5.15	4.0	4.56
3.5	2.46	2.46	2.75	3.45	3.1	2.85	3.9	3.4	3.25	3.06	4.4	6.1	5.8	4.6	5.23
4.0	2.71	2.65	3.05	3.8	3.45	3.15	4.15	3.75	3.55	3.36	4.8	6.8	6.3	5.1	5.75
4.5	2.9	2.8	3.25	4.0	3.7	3.4	4.6	4.1	3.8	3.62	5.15	7.2	6.75	5.4	6.13
5.0	3.0	2.95	3.4	4.2	3.9	3.55	5.0	4.3	3.95	3.81	5.5	7.6	7.1	5.7	6.36

YAG 40															
1.5	2.5	3.2	2.95	4.0	2.8	2.9	4.8	1.8	1.65	2.99	3.4	3.55	1.5	3.1	2.88
2.0	8.2	11.4	12.4	13.5	14.5	11.6	19.0	10.2	11.4	12.5	13.8	11.6	13.8	12.0	12.8
2.5	14.8	21.4	22.6	25.0	25.0	20.5	37.0	19.3	23.0	22.7	26.0	21.4	26.0	24.2	24.4
3.0	20.2	29.8	29.5	34.5	35.0	27.5	52.0	25.6	32.5	31.9	36.0	30.0	37.0	34.0	34.3
3.5	25.0	36.5	35.0	43.0	42.0	33.0	65.0	30.5	40.0	38.9	45.0	37.5	46.5	41.5	42.6
4.0	29.0	42.5	40.0	49.5	48.0	37.0	75.0	34.0	45.0	44.4	52.5	43.0	54.5	48.5	49.6
4.5	32.0	47.0	43.5	55.0	53.5	40.0	84.0	37.5	50.0	49.2	58.0	47.0	60.0	54.0	54.8
5.0	34.0	51.0	46.5	60.0	57.5	43.0	92.0	40.5	55.0	53.3	62.5	50.0	65.0	58.5	59.0

(a) s, p, and c indicate that the station is starboard, port, or on ship's centerline.

TABLE A.3 CUMULATIVE GAMMA DOSE (r) FOR DETECTOR STATIONS ON FLIGHT DECK AND TOP OF HOUSE AT VARIOUS TIMES AFTER SHOT 5

YAG 39										
Station Time (hr)	Flight Deck					Top of House(c)				
	1s(a)	2c(a)	3p(a)	Obs. Mean	Corr. Mean(b)	45s(a)	46p(a)	Obs. Mean	Corr. Mean(b)	
2.0	2.0	1.9	2.6	2.17	1.05	2.0	1.27	1.64	0.80	
2.5	3.45	3.65	4.7	3.93	1.98	2.95	1.88	2.42	1.22	
3.0	5.4	5.9	7.3	6.2	3.26	3.7	2.5	3.2	1.68	
3.5	7.7	9.0	10.3	9.0	4.92	4.9	3.25	4.08	2.23	
4.0	10.5	12.0	13.3	11.9	6.73	5.9	4.25	4.98	2.83	
4.5	14.0	17.0	18.0	16.3	9.59	6.9	5.1	6.0	3.53	
5.0	17.0	21.5	21.7	20.1	12.3	8.0	5.8	6.9	4.21	
6.0	22.3	27.5	27.7	25.8	17.0	9.8	7.2	8.5	5.52	
7.0	26.5	32.5	32.5	30.5	21.4	11.5	8.5	10.0	7.00	
8.0	30.0	36.0	35.7	33.9	25.0	12.5	9.3	10.5	8.02	
9.0	33.3	38.7	38.5	36.8	28.3	13.6	10.2	11.9	9.16	
10.0	36.0	41.3	41.0	39.4	31.0	14.5	10.9	12.7	10.0	
11.0	38.0	43.5	43.5	41.7	33.1	15.2	11.6	13.4	10.6	
12.0	40.0	45.7	45.5	43.7	34.1	15.8	12.2	14.0	10.9	

YAG 40										
2.0	8.0	14.0	19.0	13.7	-	6.0	5.6	5.8	-	
2.5	14.7	35.0	45.0	31.6	-	11.5	10.7	11.1	-	
3.0	23.3	88.0	80.0	63.8	-	17.0	15.7	16.4	-	
3.5	32.5	123.0	117.0	90.8	-	22.3	20.5	21.4	-	
4.0	41.0	157.0	153.0	117.0	-	28.0	26.0	27.0	-	
4.5	54.0	190.0	190.0	145.0	-	34.0	31.5	32.8	-	
5.0	71.0	225.0	220.0	172.0	-	41.0	38.0	39.5	-	
6.0	100.0	290.0	275.0	222.0	-	54.0	51.0	52.5	-	
7.0	124.0	340.0	320.0	261.0	-	67.0	64.0	65.5	-	
8.0	145.0	390.0	355.0	297.0	-	78.0	73.0	75.5	-	
9.0	165.0	427.0	385.0	325.0	-	87.0	82.0	84.5	-	
10.0	180.0	460.0	415.0	352.0	-	96.0	88.0	91.0	-	
11.0	197.0	490.0	440.0	376.0	-	105.0	95.0	100.0	-	
12.0	213.0	530.0	470.0	404.0	-	-	-	-	-	

(a) s, p, and c indicate that the station is starboard, port, or on ship's centerline.  
 (b) Corr. Mean is adjusted for difference in fallout on the two ships.  
 (c) These stations are partially shielded.

TABLE A.4 CUMULATIVE GAMMA DOSE (r) FOR DETECTOR STATIONS ON BOAT DECK AT VARIOUS TIMES AFTER SHOT 5

YAG 39						
Station Time (hr)	Boat Deck				Obs. Mean	Corr. Mean(b)
	48s(a)	49p(a)	61s	62p		
2.0	2.5	2.6	3.15		2.72	1.32
2.5	4.2	3.8	5.3		4.42	2.24
3.0	5.8	5.0	7.8		6.20	3.26
3.5	7.5	6.3	10.5		8.10	4.42
4.0	9.3	8.0	13.0		10.1	5.74
4.5	11.1	9.5	15.5		12.0	7.05
5.0	12.7	11.2	18.0		14.0	8.54
6.0	15.1	14.3	24.3		17.9	11.0
7.0	17.1	16.5	28.3		20.6	14.4
8.0	18.7	18.3	31.3		22.8	16.8
9.0	19.8	19.8	34.0	NO DATA	24.5	18.9
10.0	20.7	21.0	36.0		25.0	20.4
11.0	21.3	22.0	37.5		26.9	21.4
12.0	21.8	23.0	39.3		28.0	21.9

YAG 40						
2.0	7.0	7.7	10.0	9.5	8.55	
2.5	14.5	14.5	21.0	19.0	17.3	
3.0	21.5	21.2	33.0	28.0	25.9	
3.5	31.0	29.0	47.0	39.0	36.5	
4.0	40.0	37.0	61.0	50.0	47.0	
4.5	51.0	46.5	76.0	62.0	58.9	
5.0	63.0	56.5	91.0	75.0	71.4	
6.0	85.0	78.0	121.0	103.0	96.8	
7.0	105.0	100.0	150.0	130.0	121.0	
8.0	122.0	116.0	173.0	153.0	141.0	
9.0	137.0	132.0	195.0	173.0	159.0	
10.0	150.0	145.0	213.0	192.0	175.0	
11.0	163.0	160.0	230.0	210.0	191.0	

(a) s, p, and c indicate that the station is starboard, port, or on ship's centerline.

(b) Corr. Mean is adjusted for difference in fallout.

TABLE A.5 CUMULATIVE GAMMA DOSE (r) FOR DETECTOR STATIONS ON MAIN DECK FORWARD AT VARIOUS TIMES AFTER SHOT 5

YAG 39										
Station Time (hr)	Main Deck Forward				31s	32p	Obs. Mean	Corr. Mean(b)		
	11s(a)	13s	14p	16c						
2.0	2.0	1.7	2.8	1.9	3.0	5.0	-	1.0	2.29	1.11
2.5	3.4	3.2	5.0	5.1	3.6	5.2	-	3.4	4.12	2.08
3.0	4.8	5.4	7.8	8.0	5.9	7.8	-	5.8	6.50	3.42
3.5	6.5	8.0	11.2	11.7	9.0	11.2	-	8.8	9.49	5.18
4.0	8.5	11.2	15.0	15.7	12.3	15.7	-	12.2	12.9	7.29
4.5	11.2	15.2	19.5	20.0	16.0	20.0	-	16.0	16.8	9.89
5.0	13.5	18.7	23.0	25.0	20.0	24.0	-	20.0	20.6	12.6
6.0	17.5	24.5	29.7	32.5	27.0	31.0	-	27.0	27.0	17.8
7.0	20.5	29.3	35.0	36.0	32.0	35.5	-	32.0	31.8	22.3
8.0	22.3	33.0	39.0	43.0	36.0	40.0	-	37.0	35.5	26.1
9.0	24.0	36.0	42.5	47.0	39.0	43.0	-	37.5	38.4	29.5
10.0	25.5	37.5	44.5	50.0	41.5	46.0	-	39.5	40.0	32.0
11.0	26.7	39.0	46.5	53.0	43.5	48.0	-	41.0	42.5	34.7
12.0	27.5	40.0	48.0	55.0	44.5	50.0	-	42.0	43.9	34.3

YAG 40										
2.0	8.5	8.8	10.7	16.0	10.0	10.0	8.2	9.0	10.2	
2.5	17.0	19.0	27.0	35.0	21.0	24.0	20.0	23.0	23.3	
3.0	27.0	33.0	48.0	58.0	37.0	46.0	36.0	41.0	40.8	
3.5	39.0	50.0	73.0	82.0	60.0	70.0	57.0	64.0	61.6	
4.0	50.0	72.0	100.0	115.0	88.0	100.0	80.0	90.0	87.1	
4.5	65.0	97.0	135.0	150.0	117.0	130.0	107.0	120.0	115.0	
5.0	80.0	125.0	167.0	175.0	145.0	163.0	135.0	150.0	145.0	
6.0	113.0	160.0	225.0	250.0	210.0	238.0	205.0	227.0	211.0	
7.0	150.0	210.0	277.0	300.0	285.0	320.0	260.0	275.0	270.0	
8.0	190.0	300.0	315.0	355.0	340.0	333.0	305.0	350.0	323.0	
9.0	233.0	340.0	350.0	420.0	375.0	380.0	345.0	400.0	368.0	
10.0	270.0	390.0	380.0	570.0	440.0	420.0	385.0	440.0	407.0	
11.0	245.0	440.0	415.0	620.0	500.0	470.0	430.0	480.0	459.0	

(a) s, p, and c indicate that the station is starboard, port, or on ship's centerline.

(b) Corr. Mean is adjusted for difference in fallout.

TABLE A.6 CUMULATIVE GAMMA DOSE (r) FOR DETECTOR STATIONS ON MAIN DECK AFT AT VARIOUS TIMES AFTER SHOT 5

YAG 39						
Station Time (hr)	Main Deck Aft					
	65s(a)	67s	68p	71c	Obs. Mean	Corr. Mean(b)
2.0	3.5	3.7	5.4	2.7	3.82	1.86
2.5	6.0	7.8	7.1	5.2	6.52	3.29
3.0	8.4	12.3	12.7	7.7	10.3	5.42
3.5	11.2	17.7	16.5	11.0	14.1	7.71
4.0	14.5	23.5	21.0	15.0	18.5	10.5
4.5	17.5	30.0	26.5	19.5	23.4	13.8
5.0	21.0	35.0	31.0	23.5	27.6	16.8
6.0	26.5	45.0	40.0	30.5	35.5	23.4
7.0	31.0	52.5	47.0	36.0	41.6	29.1
8.0	35.0	58.0	52.5	41.0	46.6	34.3
9.0	38.0	62.0	57.0	44.5	50.4	38.8
10.0	40.0	66.0	62.0	48.0	54.0	42.5
11.0	42.0	68.0	65.0	50.0	56.3	44.7
12.0	43.0	70.0	68.0	52.0	58.3	45.6

YAG 40						
2.0	11.0	11.0	11.0	10.0	10.8	
2.5	24.0	23.0	25.0	23.0	23.8	
3.0	39.0	38.0	43.0	36.0	39.0	
3.5	57.0	57.0	63.0	53.0	57.5	
4.0	75.0	75.0	85.0	72.0	76.8	
4.5	98.0	95.0	110.0	93.0	99.0	
5.0	122.0	120.0	135.0	115.0	123.0	
6.0	170.0	167.0	183.0	162.0	171.0	
7.0	213.0	210.0	230.0	210.0	216.0	
8.0	250.0	250.0	275.0	245.0	255.0	
9.0	275.0	280.0	310.0	277.0	286.0	
10.0	300.0	307.0	340.0	310.0	314.0	
11.0	325.0	335.0	370.0	330.0	340.0	

(a) s, p, and c indicate that the station is starboard, port, or on ship's centerline.

(b) Corr. Mean is adjusted for difference in fallout.

TABLE A.7 GAMMA DOSE RATE (r/hr) FOR DETECTOR STATIONS IN EXTERIOR AREAS AT VARIOUS TIMES AFTER SHOT 4

YAG 39												
Station Time (hr)	Flight Deck				Roof Deck				Top of House(b)			
	1s(a)	2c	3p	Av.	48s	49p	61s	62p	Av.	45s	46p	Av.
1.5	2.37	2.3	2.0	2.22	-	2.3	1.05		2.08	1.08	0.94	1.01
2.0	1.65	2.05	2.44	2.05	2.0	1.25	1.52		1.59	0.90	0.705	0.802
2.5	1.28	1.28	1.05	1.40	2.4	0.81	1.4		1.54	0.72	0.54	0.63
3.0	0.7	0.91	1.16	0.92	1.55	0.47	0.88		0.97	0.455	0.35	0.40
3.5	0.5	0.7	0.9	0.7	1.1	0.35	0.66		0.70	0.325	0.25	0.29
4.0	0.39	0.55	0.71	0.55	0.81	0.27	0.51		0.53	0.245	0.201	0.223
4.5	0.32	0.45	0.56	0.44	0.62	0.21	0.40		0.41	0.193	0.156	0.175
5.0	0.26	0.37	0.47	0.37	0.49	0.17	0.33		0.33	0.156	0.126	0.142

YAG 40												
1.5	10.2	25.0	20.0	18.4	12.6	10.5	7.5	12.1	10.9	6.9	8.0	7.45
2.0	16.7	60.2	53.0	43.3	18.6	11.8	15.1	15.2	15.2	8.6	9.0	8.8
2.5	14.1	51.0	43.0	36.0	22.7	10.8	15.0	15.1	15.9	6.9	8.7	7.8
3.0	12.0	37.0	35.0	28.0	19.7	8.3	13.0	14.7	13.9	5.4	7.0	6.2
3.5	10.1	28.5	28.0	22.2	16.8	6.8	10.5	10.2	11.1	4.1	5.4	4.75
4.0	8.8	23.4	22.7	20.0	13.0	5.7	8.5	8.6	8.95	3.24	4.24	3.74
4.5	7.5	18.5	19.0	15.0	10.9	4.75	7.1	7.2	7.4	2.58	3.35	2.97
5.0	6.6	15.5	16.0	12.7	9.3	4.05	6.0	6.1	6.61	2.2	2.73	2.47

(a) s, p, and c indicate that the station is starboard, port or on ship's centerline.

(b) Stations 45 and 46 are partially shielded.

TABLE A.8 GAMMA DOSE RATE (r/hr) FOR DETECTOR STATIONS ON MAIN DECK AT VARIOUS TIMES AFTER SHOT 4

YAG 39															
Station Time (hr)	Main Deck Forward										Main Deck Aft				
	11s(a)	12p	13s	14p	16c	29s	30p	31s	32p	Av.	65s	67s	68p	71c	Av.
1.5	1.45	1.64	1.22	2.0	1.55	1.95	2.3	1.65	2.2	1.77	3.1	2.4	4.85	-	3.45
2.0	1.41	1.55	1.52	2.1	2.0	1.71	2.29	2.0	1.98	1.84	2.46	3.35	2.95	2.35	2.78
2.5	1.3	1.08	1.6	1.6	1.68	1.43	1.9	2.1	1.42	1.58	2.33	3.7	2.6	2.31	2.74
3.0	0.82	0.71	1.06	1.02	1.13	0.96	1.18	1.35	0.92	1.02	1.5	2.5	1.62	1.72	1.84
3.5	0.57	0.49	0.72	0.72	0.81	0.7	0.86	1.0	0.67	0.74	1.1	1.8	1.11	1.2	1.3
4.0	0.41	0.39	0.51	0.58	0.62	0.5	0.69	0.66	0.53	0.54	0.82	1.31	0.88	0.87	0.97
4.5	0.32	0.31	0.39	0.47	0.48	0.38	0.54	0.50	0.41	0.42	0.65	0.99	0.71	0.67	0.76
5.0	0.25	0.26	0.32	0.38	0.39	0.31	0.44	0.41	0.33	0.34	0.53	0.80	0.59	0.54	0.62

YAG 40															
1.5	14.9	12.2	13.8	12.3	16.8	9.6	14.2	10.4	9.5	12.6	13.2	12.5	16.1	12.8	13.7
2.0	15.9	20.0	20.0	23.7	24.3	17.9	24.5	19.1	23.2	21.0	23.2	20.5	25.1	22.2	22.8
2.5	14.2	19.3	17.0	23.1	20.5	16.8	26.0	18.5	21.9	19.7	25.0	19.5	25.1	25.0	23.7
3.0	11.2	15.7	13.5	19.0	16.5	13.9	22.1	15.8	17.9	16.2	21.0	15.2	21.2	20.0	19.4
3.5	9.0	12.6	10.4	15.3	12.9	11.3	17.1	11.4	14.6	12.7	17.0	12.3	17.0	16.2	15.6
4.0	7.4	10.2	8.3	12.7	10.7	9.0	14.3	10.1	12.0	10.5	13.7	10.2	14.3	13.2	12.9
4.5	6.1	8.3	7.3	10.8	8.9	7.3	12.2	8.6	9.6	8.8	11.1	8.5	11.6	11.0	10.6
5.0	5.2	6.9	6.6	8.2	7.7	6.2	10.2	7.3	7.8	7.4	9.6	7.2	10.2	9.3	9.1

(a) s, p, and c indicate that the station is starboard, port or on ship's centerline.

TABLE A.9 GAMMA DOSE RATE (r/hr) FOR DETECTOR STATIONS ON FLIGHT DECK AND TOP OF HOUSE AT VARIOUS TIMES AFTER SHOT 5

YAG 39									
Station Time (hr)	Flight Deck					Top of House (b)			
	1s(a)	2c	3p	Obs. Mean	Corr. Mean(c)	45s	46p	Obs. Mean	Corr. Mean(c)
2.0	2.8	2.6	3.75	3.05	1.09	2.3	1.55	1.93	0.69
2.5	3.5	3.8	4.65	3.98	1.50	2.02	1.33	1.68	0.66
3.0	4.3	5.2	5.6	5.03	2.16	2.12	1.36	1.74	0.75
3.5	5.3	6.7	6.3	6.10	2.91	2.3	1.5	1.90	0.91
4.0	6.5	8.3	7.7	7.5	4.08	2.43	1.83	2.13	1.16
4.5	7.0	9.7	9.0	8.57	5.26	2.8	1.93	2.37	1.45
5.0	5.9	7.1	7.0	6.67	4.51	2.37	1.83	2.10	1.42
6.0	5.0	5.6	5.3	5.30	4.24	1.75	1.6	1.68	1.34
7.0	4.1	4.3	4.2	4.20	3.59	1.3	1.17	1.24	1.06
8.0	3.3	3.35	3.4	3.35	2.84	1.03	0.94	0.99	0.84
9.0	2.8	2.85	2.8	2.82	2.31	0.88	0.79	0.84	0.69
10.0	2.5	2.47	2.4	2.46	1.93	0.77	0.68	0.73	0.57
11.0	2.2	2.2	2.23	2.21	1.57	0.68	0.60	0.64	0.45
12.0	1.98	1.93	2.17	2.03	1.37	0.61	0.53	0.57	0.39

YAG 40									
2.0	11.5	14.0	43.5	23.0		9.5	10.0	9.75	
2.5	15.0	66.0	59.0	46.7		10.7	9.8	10.3	
3.0	16.0	130.0	80.0	75.5		10.6	9.5	10.1	
3.5	21.0	73.0	65.0	53.0		11.5	9.9	10.7	
4.0	18.0	65.0	83.0	55.3		12.2	10.0	11.1	
4.5	30.0	78.0	68.0	58.7		13.2	12.0	12.6	
5.0	37.0	72.0	62.0	57.0		14.2	13.5	13.9	
6.0	25.0	60.0	51.0	45.5		13.3	12.7	13.0	
7.0	23.2	50.0	43.0	35.7		11.9	11.0	11.5	
8.0	20.5	43.0	37.5	33.7		10.3	9.2	9.75	
9.0	18.5	37.0	33.0	29.5		9.0	8.1	8.55	
10.0	17.3	33.0	29.0	26.6		8.2	7.3	7.75	
11.0	16.5	29.0	27.0	24.2		7.4	6.8	7.10	
12.0	15.8	26.5	24.5	22.3		6.8	6.2	6.50	

(a) s, p, and c indicate that the station is starboard, port, or on ship's centerline.

(b) These stations are partially shielded.

(c) Corr. Mean is adjusted for difference in fallout in the two ships.

TABLE A.10 GAMMA DOSE RATE (r/hr) FOR DETECTOR STATIONS ON BOAT DECK AT VARIOUS TIMES AFTER SHOT 5

YAG 39						
Station Time (hr)	Boat Deck				Obs. Mean	Corr. Mean (b)
	48s(a)	49p	61s	62p		
2.0	3.9	3.0	4.8		3.90	1.39
2.5	3.2	2.53	4.5		3.41	1.36
3.0	3.0	2.57	4.6		3.39	1.46
3.5	3.1	2.75	5.1		3.65	1.74
4.0	3.5	3.13	6.0		4.21	2.29
4.5	3.7	3.35	6.2		4.42	2.71
5.0	3.3	3.3	6.0		4.05	2.74
6.0	2.2	2.73	4.5		3.08	2.17
7.0	1.5	2.05	3.25	NO DATA	2.27	1.54
8.0	1.17	1.6	2.65		1.81	1.54
9.0	1.0	1.39	2.25		1.55	1.27
10.0	0.77	1.2	1.97		1.35	1.06
11.0	0.75	0.97	1.77		1.16	0.82
12.0	0.68	0.88	1.6		1.05	0.71

YAG 40						
2.0	14.8	13.8	20.0	18.5	16.8	
2.5	15.8	14.5	24.0	19.8	18.5	
3.0	16.2	14.5	24.3	21.0	19.0	
3.5	17.5	15.5	26.5	22.5	20.5	
4.0	20.0	16.2	28.8	25.0	22.5	
4.5	22.0	18.5	30.7	27.5	24.7	
5.0	22.5	20.7	33.0	29.3	26.4	
6.0	21.0	21.5	31.0	28.7	25.6	
7.0	18.8	19.8	27.0	26.0	22.9	
8.0	16.2	17.0	23.0	21.0	19.3	
9.0	14.2	14.7	20.3	18.8	17.0	
10.0	12.7	13.3	18.3	17.2	15.4	
11.0	11.7	12.0	17.0	15.7	14.1	
12.0	10.8	10.8	15.7	14.5	13.0	

- (a) s, p, and c indicate that the station is starboard, port, or on ship's centerline.  
 (b) Corr. Mean is adjusted for difference in fallout.

TABLE A.11 GAMMA DOSE RATE (r/hr) FOR DETECTOR STATIONS ON MAIN DECK FORWARD AT VARIOUS TIMES AFTER SHOT 5

YAG 39										
Station Time (hr)	Main Deck Forward								Obs. Mean	Corr. Mean (b)
	11s(a)	13s	14p	16c	29s	30p	31s	32p		
2.0	3.07	3.3	4.65	4.6	3.5	4.2	-	3.6	3.87	1.38
2.5	2.8	3.65	4.7	5.25	3.8	4.9	-	4.1	4.18	1.64
3.0	3.35	4.55	5.7	6.1	5.0	6.0	-	5.0	5.10	2.19
3.5	3.85	5.8	6.8	7.2	6.5	7.6	-	6.1	6.28	2.99
4.0	4.5	7.1	8.0	8.7	7.8	9.0	-	7.2	7.48	4.07
4.5	5.05	7.6	9.1	10.5	8.5	10.2	-	8.2	8.45	5.17
5.0	4.55	6.9	8.0	9.0	7.7	7.5	-	7.5	7.30	4.93
6.0	3.45	5.6	5.8	7.1	6.1	5.8	-	5.6	5.65	4.52
7.0	2.5	4.55	4.35	5.5	4.2	4.1	-	4.0	4.17	3.57
8.0	1.97	3.4	3.33	4.4	3.3	3.45	-	3.0	3.27	2.77
9.0	1.63	2.6	2.67	3.65	2.7	3.0	2.6	2.4	2.66	2.18
10.0	1.43	2.07	2.45	3.1	2.35	2.75	2.1	2.05	2.29	1.79
11.0	1.22	1.78	2.2	2.6	2.1	2.6	1.78	1.75	2.01	1.43
12.0	1.07	1.58	2.1	2.15	1.87	2.47	1.6	1.6	1.79	1.21

YAG 40										
2.0	14.4	15.5	26.0	31.5	18.5	26.0	18.0	22.0	21.5	
2.5	18.0	25.5	38.0	45.5	30.0	36.0	28.0	38.0	32.4	
3.0	20.5	35.3	49.5	52.0	40.0	45.0	40.0	42.0	40.5	
3.5	28.0	44.0	55.0	60.0	49.0	59.0	56.0	51.0	50.3	
4.0	26.0	41.5	67.0	62.0	51.0	66.0	61.0	59.0	54.3	
4.5	29.0	50.0	66.0	75.0	62.0	67.0	62.0	65.0	59.5	
5.0	33.5	61.0	64.0	98.0	72.0	71.0	63.0	70.0	66.5	
6.0	36.0	67.0	60.0	96.0	77.0	67.0	62.0	70.0	67.0	
7.0	36.0	60.0	47.5	85.0	67.0	58.0	55.5	62.5	59.0	
8.0	34.0	51.5	39.5	73.0	56.0	46.0	46.5	54.0	50.3	
9.0	26.0	47.5	33.0	64.0	48.5	42.0	42.0	47.0	43.5	
10.0	22.0	41.0	29.7	57.0	43.0	37.5	38.0	43.0	39.0	
11.0	19.7	38.0	26.5	52.0	40.5	33.5	35.3	40.0	35.7	
12.0	18.0	35.0	24.0	48.0	38.5	30.5	33.0	37.0	33.1	

- (a) s, p, and c indicate that the station is starboard, port, or on ship's centerline.  
 (b) Corr. Mean is adjusted for difference in fallout.

TABLE A.12 GAMMA DOSE RATE (r/hr) FOR DETECTOR STATIONS ON MAIN DECK AFT AT VARIOUS TIMES AFTER SHOT 5

YAG 39						
Station Time (hr)	Main Deck Aft				Obs. Mean	Corr. Mean (b)
	65s(a)	67s	68p	71c		
2.0	5.25	8.8	6.6	4.55	6.30	2.25
2.5	5.0	8.4	6.8	5.2	6.35	2.49
3.0	5.3	9.3	7.5	6.1	7.05	3.03
3.5	5.2	10.8	8.6	7.0	8.05	3.83
4.0	6.4	12.3	9.5	8.0	9.05	4.92
4.5	7.2	14.0	10.5	9.2	10.2	6.22
5.0	6.2	10.7	9.5	7.8	8.55	5.78
6.0	5.25	8.7	8.3	7.4	7.41	5.93
7.0	4.05	6.0	6.2	6.3	5.64	4.82
8.0	3.1	4.8	5.2	3.8	4.23	3.59
9.0	2.65	3.85	4.4	3.2	3.53	2.89
10.0	2.2	3.3	3.7	2.8	3.00	2.35
11.0	1.9	2.85	3.1	2.37	2.56	1.82
12.0	1.7	2.45	2.65	2.05	2.21	1.49

YAG 40						
2.0	21.0	21.5	25.0	20.5	22.0	
2.5	29.0	29.5	34.5	29.0	30.5	
3.0	33.5	34.5	37.0	32.5	34.4	
3.5	37.0	40.0	44.0	36.5	39.4	
4.0	40.5	44.5	48.0	41.0	43.5	
4.5	46.0	47.0	52.5	46.3	48.0	
5.0	49.5	50.0	55.0	50.0	51.1	
6.0	47.0	47.0	52.0	48.0	48.5	
7.0	42.0	41.0	44.5	42.0	42.4	
8.0	36.0	35.0	39.0	36.0	36.5	
9.0	32.0	31.5	35.0	31.5	32.5	
10.0	28.5	29.0	31.5	26.3	29.3	
11.0	26.0	26.3	28.5	25.7	26.6	
12.0	23.5	24.3	26.5	23.5	24.5	

(a) s, p, and c indicate that the station is starboard, port, or on ship's centerline.

(b) Corr. Mean is adjusted for difference in fallout.

TABLE A.13 CUMULATIVE GAMMA DOSE (mR) FOR INTERIOR DETECTOR STATIONS AT VARIOUS TIMES AFTER SHOT 4

Station Time (hr)	UNSHIELDED STATIONS IN SUPERSTRUCTURE ABOVE MAIN DECK						COMPARTMENTS ADJACENT			BOTTOM #2HOLD 28c	BOLLER FRONT 58c	RECORD ROOM 64p	
	38(a)	39c	41c	47p	60p	63s	Av.	ENGINE 55s	CASING 56p				2nd DECK Av.
YAG 39													
1.5	110	230	41	120	82	13	127	22	18	20	67	-	4.1
2.0	445	68	164	390	232	470	397	48	43	45.5	170	4.0	17.4
2.5	190	1110	283	580	355	72	640	82	70	76	255	14.0	28.9
3.0	1030	1450	370	710	445	910	819	114	85	99.5	315	19.0	38.0
3.5	1190	1710	430	800	500	1060	948	130	96	113	350	22.5	44.5
4.0	1320	1900	480	870	550	1160	1050	145	1.5	125	383	25.5	50.0
4.5	1420	2050	525	920	580	1220	1120	156	112	134	405	28.0	54.0
5.0	1510	2180	550	960	610	1280	1180	163	119	141	425	30.5	57.4
YAG 40													
1.5	650	730	240	1000	290	770	613	23.8	39	31.4	180	1.54	-
2.0	350	4700	1100	275	1190	2950	2620	70	111	90.5	720	6.5	16.4
2.5	700	8600	2010	4750	214	5650	5030	138	176	157	114	11.9	27.1
3.0	10400	12000	2830	6500	2900	8200	714	204	235	213.5	1510	16.5	37.0
3.5	1340	15000	3500	7900	3550	10300	8940	255	284	269.5	1820	20.7	43.2
4.0	159.0	17500	4070	8800	4050	11700	10300	302	310	306	2090	24.1	48.6
4.5	17900	193.0	4530	9500	4450	13100	11500	330	347	342.5	2290	27.0	52.2
5.0	19200	20700	4900	10100	4800	14200	12300	350	370	367.5	2460	28.9	52.8

(a) s, p, and c indicate that the station is starboard, port, or ship's centerline.



TABLE A.14 CUMULATIVE GAMMA DOSE (r) FOR UNSHIELDED STATIONS IN SUPERSTRUCTURE ABOVE MAIN DECK AT VARIOUS TIMES AFTER SHOT 5

Station	UNSHIELDED STATIONS IN SUPERSTRUCTURE ABOVE MAIN DECK							
	38(c)	39c	41c	47p	53p	63c	Obs. Mean	Corr. Mean(b)
	YAG 39							
2.0	0.47	0.70	0.29	0.45	0.32	0.80	0.606	0.294
2.5	0.97	1.5	0.53	0.69	0.48	1.2	0.895	0.452
3.0	1.63	2.4	0.80	0.98	0.65	1.73	1.37	0.722
3.5	2.5	3.4	1.15	1.43	0.90	2.33	1.95	1.07
4.0	3.4	4.5	1.5	1.9	1.17	2.95	2.57	1.46
4.5	4.4	6.3	1.9	2.45	1.4	3.6	3.34	1.97
5.0	5.4	8.0	2.25	2.95	1.6	4.25	4.08	2.49
6.0	7.2	10.8	2.8	3.85	2.0	5.5	5.36	3.53
7.0	8.6	13.2	3.3	4.65	2.3	6.5	6.43	4.50
8.0	9.6	15.0	3.6	5.25	2.57	7.3	7.22	5.31
9.0	10.5	16.7	3.85	5.7	2.73	7.9	7.90	6.08
10.0	11.3	18.2	4.1	6.2	2.9	8.5	8.53	6.72
11.0	12.0	19.3	4.3	6.4	3.0	8.9	8.98	7.13
12.0	12.5	20.3	4.45	6.7	3.05	9.3	9.38	7.33
	YAG 40							
2.0	5.7	7.0	3.65	2.1	0.38	3.0	3.64	
2.5	13.0	12.5	4.7	3.9	1.6	7.0	7.12	
3.0	17.3	21.0	5.9	6.3	2.8	11.2	10.8	
3.5	22.7	31.0	7.6	9.0	4.2	15.5	15.0	
4.0	30.0	44.5	10.0	12.0	5.7	20.0	20.4	
4.5	43.0	60.0	13.0	15.5	7.5	25.0	27.3	
5.0	56.0	78.0	16.0	19.0	9.4	30.0	34.7	
6.0	82.0	115.0	22.5	27.0	13.0	40.0	49.9	
7.0	105.0	147.0	28.0	33.5	17.0	49.0	63.3	
8.0	125.0	173.0	33.0	39.5	20.0	58.0	74.8	
9.0	143.0	200.0	37.5	44.5	22.7	66.0	85.6	
10.0	160.0	220.0	41.5	49.0	24.5	72.0	94.5	
11.0	171.0	240.0	44.5	53.5	26.7	78.0	102.0	
12.0	182.0	258.0	47.5	57.0	28.3	84.0	109.0	

(a) p and c indicate that the station is to port or on ship's centerline.  
 (b) Corr. Mean is adjusted for difference in fallout on the two ships.

TABLE A.15 CUMULATIVE GAMMA DOSE (mr) FOR DETECTOR STATIONS BELOW MAIN DECK AT VARIOUS TIMES AFTER SHOT 5

Station Time (hr)	COMPARTMENTS ADJACENT TO ENGINE CASING - SECOND DECK						
	YAG 39				YAG 40		
	55p(a)	56p	Obs. Mean	Corr. Mean(b)	55a	56p	Obs. Mean
2.0	80.0	59.0	69.5	33.7	85.0	90.0	87.5
2.5	138.0	97.0	118.0	59.5	190.0	210.0	200.0
3.0	188.0	138.0	162.0	85.2	280.0	320.0	300.0
3.5	260.0	185.0	223.0	122.0	390.0	450.0	420.0
4.0	350.0	240.0	295.0	168.0	520.0	570.0	545.0
4.5	440.0	300.0	370.0	218.0	670.0	720.0	695.0
5.0	520.0	350.0	435.0	269.0	810.0	850.0	830.0
6.0	650.0	450.0	550.0	362.0	1100.0	1180.0	1140.0
7.0	750.0	480.0	615.0	430.0	1320.0	1500.0	1420.0
8.0	820.0	510.0	665.0	489.0	1530.0	1800.0	1670.0
9.0	900.0	535.0	708.0	545.0	1700.0	2000.0	1850.0
10.0	920.0	560.0	740.0	582.0	1850.0	2150.0	2000.0
11.0	950.0	600.0	775.0	615.0	1900.0	2250.0	2120.0
12.0	980.0	630.0	805.0	629.0	2100.0	2320.0	2210.0

Station Time (hr)	BOILER FRONT		SYSTEM #2 HOLD		RECOILER ROOM	
	YAG 39	YAG 40	YAG 39	YAG 40	YAG 39	YAG 40
	59c	58c	59c	58c	64p	64p
2.0	-	7.0	275.0	133.0	29.0	14.1
2.5	13.5	14.5	520.0	203.0	54.0	27.3
3.0	25.0	21.3	800.0	330.0	90.0	42.1
3.5	46.0	30.0	900.0	492.0	120.0	59.0
4.0	70.0	38.0	1180.0	670.0	145.0	62.4
4.5	95.0	47.0	1520.0	894.0	195.0	109.0
5.0	125.0	58.0	1800.0	1100.0	230.0	140.0
6.0	185.0	69.0	2300.0	1510.0	330.0	217.0
7.0	237.0	110.0	2700.0	1890.0	420.0	290.0
8.0	275.0	128.0	3050.0	2240.0	500.0	350.0
9.0	307.0	147.0	3270.0	2520.0	570.0	400.0
10.0	335.0	162.0	3450.0	2710.0	640.0	430.0
11.0	353.0	175.0	3550.0	2820.0	700.0	460.0
12.0	370.0	187.0	3650.0	2850.0	760.0	490.0

(a) a, p, and c indicate that the station is starboard, port, or on ship's centerline.  
 (b) Corr. means that the station is adjusted for the difference in fallout on the two ships.

TABLE A.16 GAMMA DOSE RATE (mr/hr) FOR DETECTOR STATIONS (INTERIOR) AT VARIOUS TIMES AFTER SHOT 4

Station Time (hr)	UNSHIELDED STATIONS IN SUPERSTRUCTURE ABOVE MAIN DECK						COMPARTMENTS ADJACENT			BOTTOM	BOILER RECORD		
	38(a)	39c	41c	47p	60p	63a	Av.	ENGINE 55a	CASING 57c	2nd DECK Av.	#2 HOLD 28c	FRONT ROOM 58c	ROOM 64p
YAG 39													
1.5	218	725	174	250	325	790	414	52	52	52	255	4.3	20.5
2.0	680	960	253	510	290	535	538	67	54	60.5	208	9.4	30.0
2.5	600	875	236	425	264	475	479	78	42	60	164	12.2	26.8
3.0	410	610	174	285	170	315	327	47.5	27.4	37.5	97	9.7	17.5
3.5	290	460	130	165	114	237	233	33.5	22.0	27.8	70	8.7	12.8
4.0	218	355	97	121	93	186	178	24.5	15.0	19.8	55	7.2	9.7
4.5	185	270	58	98	68	144	137	18.2	12.5	15.4	43	5.9	7.6
5.0	153	215	47.5	82	56	115	111	14.4	10.8	12.6	35	4.9	6.2
YAG 40													
1.5	3000	3800	1091	3450	1400	3600	2720	63	98	80.5	630	7.2	22
2.0	6900	8100	1780	3850	1710	5300	4610	114	133	123.5	1040	10.85	23
2.5	7600	8100	1950	3700	1750	5400	4750	145	125	135	970	10.85	23.1
3.0	6700	6800	1680	2950	1450	4550	4020	117	102	109.5	730	9.2	16.0
3.5	5200	5400	1340	2420	1170	3600	3190	97	84	90.5	580	7.65	11.8
4.0	4250	4200	1100	1970	970	2920	2570	77.5	67	72.3	470	6.1	9.2
4.5	3500	3700	910	1610	790	2470	2160	65	56	60.5	390	5.07	7.25
5.0	3000	3100	760	1340	640	2110	1830	53	46.5	49.8	325	4.35	5.9

(a) s, p, and c indicate that the station is starboard, port, or on ship's centerline.

TABLE A.17 GAMMA DOSE RATE (r/hr) FOR DETECTOR STATIONS IN SUPERSTRUCTURE ABOVE MAIN DECK AT VARIOUS TIMES AFTER SHOT 5

Station Time (hr)	UNSHIELDED STATIONS IN SUPERSTRUCTURE ABOVE MAIN DECK						Obs. Mean	Corr. Mean (b)
	38(a)	39c	41c	47p	53p	63c		
YAG 39								
2.0	0.90	1.13	0.42	0.78	0.33	1.05	0.778	0.278
2.5	1.2	1.5	0.485	0.72	0.34	1.07	0.886	0.348
3.0	1.5	2.0	0.54	0.79	0.365	1.15	1.06	0.455
3.5	1.78	2.5	0.67	0.90	0.405	1.23	1.25	0.595
4.0	2.2	3.1	0.82	1.0	0.455	1.30	1.48	0.809
4.5	2.6	3.75	0.77	1.22	0.52	1.52	1.73	1.06
5.0	2.35	3.55	0.72	1.08	0.49	1.40	1.60	1.08
6.0	1.78	3.15	0.56	0.90	0.40	1.29	1.35	1.08
7.0	1.27	2.4	0.43	0.68	0.28	0.93	1.00	0.855
8.0	1.01	1.9	0.315	0.51	0.193	0.69	0.771	0.653
9.0	0.83	1.43	0.263	0.42	0.16	0.56	0.611	0.501
10.0	0.70	1.08	0.223	0.36	0.123	0.50	0.498	0.389
11.0	0.60	0.90	0.193	0.295	0.107	0.44	0.423	0.300
12.0	0.50	0.79	0.167	0.255	0.093	0.39	0.376	0.247
YAG 40								
2.0	5.0	8.4	2.05	4.9	2.8	6.5	4.94	
2.5	9.0	13.3	2.85	5.05	2.8	7.5	6.61	
3.0	12.0	17.0	3.5	5.0	2.8	8.2	8.08	
3.5	15.8	23.0	4.25	5.4	3.07	8.8	10.1	
4.0	19.0	28.5	4.9	6.2	3.3	9.5	11.9	
4.5	23.5	34.0	5.9	7.1	3.5	10.5	14.1	
5.0	26.3	38.0	6.5	7.7	3.8	11.0	15.0	
6.0	26.5	38.0	6.7	7.9	3.9	10.7	15.3	
7.0	21.5	31.5	5.8	7.0	3.45	9.5	13.1	
8.0	18.0	27.0	4.9	5.95	3.0	8.1	11.2	
9.0	16.3	23.0	4.25	5.15	2.55	7.2	9.78	
10.0	14.7	20.7	3.74	4.55	2.15	6.3	8.69	
11.0	13.3	18.5	3.3	4.0	1.83	5.6	7.78	
12.0	12.2	16.8	3.05	3.65	1.68	5.0	7.08	

(a) p and c indicate that the station is port or on ship's centerline.

(b) Corr. means is adjusted for difference in distance from the two ships.

TABLE A.18 GAMMA DOSE RATE (mr) FOR DETECTOR STATIONS BELOW MAIN DECK AT VARIOUS TIMES AFTER SHOT 5

COMPARTMENTS ADJACENT TO ENGINE CASING - BROOMHOLD							
Station Time (hr)	YAG 39				YAG 40		
	55a(a)	56p	Obs. Mean	Corr. Mean(b)	55a	56p	Obs. Mean
2.0	137.0	78.0	108.0	38.4	170.0	190.0	180.0
2.5	116.0	79.0	97.5	38.3	185.0	205.0	195.0
3.0	140.0	89.0	115.0	49.2	200.0	215.0	208.0
3.5	172.0	103.0	138.0	65.5	225.0	255.0	240.0
4.0	200.0	115.0	158.0	86.0	265.0	275.0	270.0
4.5	225.0	130.0	178.0	109.0	300.0	310.0	305.0
5.0	203.0	120.0	162.0	110.0	310.0	350.0	330.0
6.0	137.0	92.0	115.0	91.5	280.0	345.0	313.0
7.0	88.0	66.0	77.0	66.0	230.0	307.0	269.0
8.0	66.0	47.0	56.5	47.9	185.0	240.0	213.0
9.0	52.0	37.5	44.8	36.7	157.0	200.0	179.0
10.0	42.0	31.0	36.5	28.5	135.0	175.0	155.0
11.0	34.4	22.0	28.0	19.9	121.0	155.0	138.0
12.0	26.0	19.0	22.5	15.2	107.0	138.0	123.0

UNSHIELDED BOILER FRONT BOTTOM #2 HOLD					RECORDER ROOM				
Station Time (hr)	YAG 39		YAG 40		YAG 39		YAG 40		
	58c	Corr.	58c	Corr.	64p	Corr.	64p		
2.0	28.0	10.0	-	350.0	125.0	-	47.0	16.8	35.0
2.5	37.0	14.5	-	387.0	152.0	1770	48.0	18.8	35.0
3.0	28.0	12.0	17.0	420.0	180.0	1950	51.0	21.9	40.0
3.5	37.0	17.5	19.5	470.0	224.0	2180	61.0	29.0	42.0
4.0	47.0	25.7	21.5	560.0	306.0	2400	71.0	35.8	50.0
4.5	51.0	31.1	24.5	640.0	390.0	2770	85.0	51.8	58.0
5.0	74.0	50.0	27.0	575.0	388.0	2970	93.0	62.8	68.0
6.0	57.0	45.6	27.3	450.0	360.0	2770	97.0	77.6	73.0
7.0	46.0	39.3	24.0	330.0	282.0	2320	91.0	77.8	67.0
8.0	39.0	33.0	20.5	250.0	212.0	1950	73.0	61.8	51.0
9.0	33.5	27.4	18.5	200.0	164.0	1650	56.0	45.8	42.0
10.0	29.0	22.7	16.0	165.0	129.0	1470	49.0	38.3	37.0
11.0	27.3	19.4	14.0	145.0	103.0	1350	44.0	31.2	32.0
12.0	25.7	17.4	12.3	127.0	85.8	1270	38.0	25.7	28.0

(a) s, p, and c indicate that the station is starboard, port, or on ship's centerline.

(b) Corr. means that the station is adjusted for difference in fallout on the two ships.

TABLE A.19 STARBOARD BOILER CONTRIBUTION TO THE RADIATION FIELD IN THE FIRING ISLE AS RECORDED AT STATION 59. CUMULATIVE GAMMA DOSE (mr) AND GAMMA DOSE RATE (mr/hr) AT VARIOUS TIMES AFTER SHOTS 4 and 5. YAG 39/YAG 40 RATIO

Time (hr)	CUMULATIVE GAMMA DOSE			GAMMA DOSE RATE				
	YAG 39 Corr. (a)	YAG 40	Ratio	YAG 39 Corr.	YAG 40 Corr.	Ratio	YAG 39 YAG 40 Ratio	
Shot 5								
2.0	4.2	2.04	1.11	1.84	10.7	3.8	2.8	1.37
2.5	9.5	4.8	2.6	1.85	13.7	5.4	3.3	1.63
3.0	17.0	8.95	4.4	2.03	18.0	7.7	4.0	1.92
3.5	28.0	15.3	6.1	2.51	22.5	10.7	4.65	2.31
4.0	41.0	23.3	8.0	2.92	25.0	13.7	5.5	2.46
4.5	55.0	32.4	10.5	3.09	36.0	22.0	6.1	2.60
5.0	70.0	42.7	13.2	3.24	34.0	23.0	6.2	3.70
6.0	97.0	63.8	20.0	3.19	27.7	22.2	6.1	3.63
7.0	120.0	83.9	28.0	3.23	23.5	20.0	5.5	3.60
8.0	138.0	102.0	31.0	3.29	20.0	16.9	5.0	3.49
9.0	157.0	121.0	35.0	3.46	17.5	14.4	4.6	3.12
10.0	173.0	136.0	38.5	3.53	16.0	12.5	4.2	2.98
11.0	187.0	149.0	41.5	4.49	13.8	9.8	3.9	2.51
12.0	200.0	160.0	44.0	4.55	12.2	8.9	3.55	2.51
Shot 4								
1.5	-	-	-	-	1.9	1.22	1.56	
2.0	2.25	0.94	2.39	4.26	6.2	2.23	1.67	
2.5	5.0	1.5	3.33	6.2	2.0	2.37	2.62	
3.0	7.8	2.6	3.00	5.0	1.64	2.0	2.50	
3.5	10.6	3.9	2.72	3.9	1.33	1.64	2.35	
4.0	12.6	4.9	2.57	5.55	1.12	1.33	4.17	
4.5	14.9	5.6	2.66	3.75	1.12	1.12	3.35	
5.0	16.6	6.1	2.72	3.15	0.96	0.96	3.28	

(a) Corr. indicated that the value has been corrected for difference in fall-out on the two ships.

## Appendix B

# SUPPLEMENTARY MATERIAL ON SHIP SHIELDING

### B.1 DERIVATION OF THE SHIELDING FACTOR

B.1.1 Components of the Shielding Factor. Let the dose rate, or intensity, measured above the deck be  $I_{dk}$ , which may consist of the sum of three elements:

- $I_s$  - contribution from activity deposited on weather surfaces
- $I_a$  - contribution from activity in the air during the fallout event
- $I_w$  - contribution from activity in the sea water.

For this discussion let the ratio of the dose rate in an interior compartment to that on the deck define the shielding factor  $f$ , with the appropriate subscript, for each of the three components. Then the overall shielding factor  $F$ , defined simply as the ratio of the interior dose rate to that on deck, due to all radioactive sources, is:

$$F = I/I_{dk} = \frac{f_s I_s + f_a I_a + f_w I_w}{I_s + I_a + I_w} \quad (B.1)$$

Now each  $f$  depends on the energy spectrum of the radiations, on the geometry of the radioactive sources, and on the characteristics of the ship. The value of  $F$ , however, is not uniquely determined by the individual  $f$ 's, but depends also on the values of the radiation components. Therefore, evaluation of the overall shielding factor for any fallout situation requires a knowledge of all six of the variables in Equation B.1.

Some conclusions regarding the relation between  $F$  and  $f_s$  may be made by subtracting  $f_s$  from both sides of Equation B.1, giving:

$$F - f_s = (f_a - f_s) \frac{I_a}{I_{dk}} + (f_w - f_s) \frac{I_w}{I_{dk}} \quad (B.2)$$

If the ship is in the fallout event and in contaminated water,

$$F \geq f_s \text{ if } (f_a - f_s) I_a + (f_w - f_s) I_w \geq 0 \quad (B.3)$$

<sup>1</sup> This presentation is somewhat simplified in that the quantity  $f I$  may consist of the sum of several such terms. This would be the case if more than one weather surface contributed significantly to the radiation level at the point of interest, e. g., activity deposited on the upper deck and activity deposited on the hull.

If the fallout has stopped but the ship is still in contaminated water,  $I_a = 0$ , and

$$F \geq f_s \text{ if } (f_w - f_s) I_w \geq 0 \quad (\text{B.4})$$

If the ship is out of the fallout event and out of the region of contaminated water,  $I_a = 0$ ,  $I_w = 0$ , and

$$F = f_s \quad (\text{B.5})$$

B.1.2 Ratio of Shielding Factors, YAG 39 to YAG 40. It is assumed that the two ships are sufficiently close together so that they are subjected to the same gross fallout event. Small scale inhomogeneities in the fallout, however, can cause differences in the activity deposited from point to point on a given ship. At similar locations on the two ships, some variation in the amount of activity available to be deposited can also be expected. To account for such a possibility, it will be assumed that the amount of activity available to be deposited on weather surfaces of YAG 39 differs from that on YAG 40 by a factor  $k_s$ , which is not likely to be much greater or less than 1. Such small scale inhomogeneities are likely to have negligible effect on the dose rate from waterborne or airborne activity. In the water, the activity concentration should tend to be fairly uniform because of constant turbulent mixing. The dose rate from airborne activity, on the other hand, is due to sources distributed through a large volume about the ship, so that the effect of small scale regions of greater and lesser activity concentration than the average should tend to be smoothed out. It will be assumed, therefore, that the contribution from airborne and waterborne activity is the same for both ships. Finally, it is assumed that the effect of washdown reduces the contribution of weather surfaces on YAG 39 by a factor  $\alpha$ .

From these assumptions:

$$\frac{I_{s39}}{I_{s40}} = k_s \alpha \quad (\text{B.6})$$

$$\frac{I_{a39}}{I_{a40}} = 1$$

$$\frac{I_{w39}}{I_{w40}} = 1$$

In terms of  $I_{s40} = I_s$ , let

$$\frac{I_{dk39}}{I_{dk40}} = \frac{k_s \alpha I_s + I_a + I_w}{I_s + I_a + I_w} = r \quad (\text{B.7})$$

The ratio of overall shielding factors at any given location is:

$$\frac{F_{39}}{F_{40}} = \frac{k_s \alpha f_s I_s + f_a I_a + f_w I_w}{r [f_s I_s + f_a I_a + f_w I_w]} \quad (\text{B.8})$$

From this expression, the ratio of shielding factors can vary between the following limits:

$$0 \leq \frac{F_{39}}{F_{40}} \leq \frac{1}{r} \quad (\text{B.9})$$

for  $k_s \alpha \leq 1$ , or:

$$0 \leq \frac{F_{39}}{F_{40}} \leq \frac{k_s \alpha}{r} \quad (\text{B.10})$$

for the more unlikely case where  $k_s \alpha \geq 1$ .

From Equation B.8, it is apparent that if the contribution from airborne and waterborne sources is negligible compared to that from weather surfaces, then  $F_{39}/F_{40} = 1$ . Conversely, when the contribution from weather surfaces becomes negligible compared to that from airborne and waterborne sources, then  $F_{39}/F_{40}$  approaches  $1/r$ .

Since  $r$  is comparable to 1 minus the washdown effectiveness (expressed as a fraction), determined in Chapter 2 to be of the order of 0.05 to 0.1, it is possible, in locations well-shielded from weather surfaces, for the overall shielding factor on YAG 39 to be an order of magnitude greater than on YAG 40.

From Equation B.8 the condition that  $F_{39}/F_{40} \geq 1$  is:

$$(f_a - f_s) I_a + (f_w - f_s) I_w \geq 0 \text{ for } k_s \alpha < 1 \quad (\text{B.11})$$

which is identical to the condition that  $F \geq f_s$ , as given by Equation B.3.

**B.1.3 Relation Between  $f_s$  and  $F$ .** The shielding factor for weather surface contamination can be estimated from measurements of the overall shielding factor on the two ships in the following way. From the assumptions of Section B.1.2, the difference in deck intensities is given by:

$$I_{dk40} = I_s + I_a + I_w$$

$$\frac{I_{dk39}}{I_{dk40}} = \frac{k_s \alpha I_s + I_a + I_w}{I_s (1 - k_s \alpha)} \quad (\text{B.12})$$

The difference in intensities at a shielded location is given by:

$$I_{40} = f_s I_s + f_a I_a + f_w I_w$$

$$\frac{I_{39}}{I_{40} - I_{39}} = \frac{k_s \alpha f_s I_s + f_a I_a + f_w I_w}{f_s I_s (1 - k_s \alpha)} \quad (\text{B.13})$$

From these two equations, and recalling that  $r = I_{dk39}/I_{dk40}$ ,

$$f_s = \frac{F_{40} - rF_{39}}{1 - r} \quad (\text{B.14})$$

To show more clearly the relation between  $f_s$  and  $F$ , this expression may be rewritten either as

$$f_s = F_{40} \left[ \frac{\frac{1}{r} - \frac{F_{39}}{F_{40}}}{\frac{1}{r} - 1} \right] \quad (\text{B.15})$$

or:

$$f_s = F_{39} \left[ \frac{\frac{1}{r} \frac{F_{40}}{F_{39}} - 1}{\frac{1}{r} - 1} \right] \quad (\text{B.16})$$

Except in the instrument recording room, the observed values of  $F_{39}/F_{40}$  are in the neighborhood of  $1\frac{1}{2}$  to 2. The observed values of  $r$ , however, are of the order of 10 or 20. From Equation B.15, it can be inferred that  $f_s$  is less than  $F_{40}$ , but by at most about 20 percent. On the other hand, from Equation B.16,  $f_s$  may be less than half the value of  $F_{39}$ . In the heavily shielded recorder room,  $F_{40}/F_{39}$  and  $1/r$  are of the same order of magnitude; hence at this location  $f_s$  may be considerably less than  $F_{40}$  and more than an order of magnitude less than  $F_{39}$ .

## B.2 EVALUATION OF THE SHIELDING FACTOR UNDER A 2-IN. THICK DECK

The dose rate,  $I$ , measured under the two 6-ft square plates, due to sources on the upper deck, can be separated into two components:  $I_{tr}$ , from radiations transmitted through the plates, and  $I_{sc}$ , from radiations which do not pass through the plate. These latter radiations may consist of gamma rays scattered in an upward direction by the air and by the second deck and also of rays traveling directly to the detectors from relatively distant sources on the upper deck. These radiations might not contribute more than a few percent to the total reading if the plates were not present. However, because of the large attenuation of radiations passing through the plates,  $I_{tr}$  and  $I_{sc}$  can be of the same order of magnitude.

To obtain a better estimate of the dose rate under a large 2-in.-thick deck, an attempt has been made to eliminate  $I_{sc}$  in the following way. Assume  $I_{sc}$  is the same for both the 2-in. and 4-in. plates. Let  $I_{tr}$  for the 4-in. plate equal some factor  $k$  times  $I_{tr}$  for the 2-in. plate. Then

$$I_2'' = I_{tr} + I_{sc} \quad (\text{B.17})$$

$$I_4'' = kI_{tr} + I_{sc}$$

from which

$$I_{tr} = \frac{I_2'' - I_4''}{1 - k}$$

In terms of shielding factors,  $F = I/I_{dk}$  where  $I_{dk}$  is the dose rate measured on the upper deck above the plates,

$$F_{tr} = \frac{F_2'' - F_4''}{1 - k} \quad (B.19)$$

In Section 3.4.4 of the text the quantity  $F_2'' - F_4''$  has been used as an estimate of the shielding factor which would be measured beneath a 2-in thick deck. On the basis of the steel pipe absorption data,  $k$  is less than about 0.15, so that  $F_2'' - F_4''$  should be within 20 percent of  $F_{tr}$ .

### B.3 CALCULATION OF SHIELDING FACTORS FOR DEPOSITED ACTIVITY

**B.3.1 Basic Approach.** Consider a steel plate with isotropic radioactive sources uniformly distributed over one surface. Assume that the energy spectrum and the multiple scattering buildup characteristics of the radiations are such that the dose rate from a beam of the radiations traveling through an absorbing medium is attenuated as  $e^{-\bar{u}s}$ , where  $s$  is the thickness of absorber and  $\bar{u}$  the apparent absorption coefficient as determined from Section 3.4.3. This attenuation might be measured by an isotropic detector receiving radiations incident on it from all directions.

Suppose there are, in general, several absorbers (steel plates and intervening air). Then, considering also geometrical attenuation (inverse square law), the dose rate  $dI$  at any point due to the sources distributed over an element of area  $dA$  is given by:

$$dI = I_0 e^{-\bar{u}s} \frac{dA}{4\pi (\Sigma s)^2} \quad (B.20)$$

where  $I_0$  represents the source strength, and is equal to  $4\pi$  times the dose rate measured at unit distance from a unit area of the source. The summation is taken over all media between the source and the receiver.<sup>1</sup>

Integration of Equation B.20 over the entire area containing radioactive sources will give the dose rate  $I$  at any point in terms of  $I_0$ .

Letting  $z$  represent the total thickness of steel between the contamination and the point of interest and  $h$  the distance of the point from a contaminated rectangular plate, the integral of Equation B.20 can be expressed as:

$$I = \frac{I_0}{2} [-Ei(-uh) + Ei(-ux_0)] \quad (B.21)$$

<sup>1</sup>The approach here follows that of Reference 1 except that dose rate is used in place of radiation intensity (Mev/sq cm/sec), and the expression for attenuation  $Be^{-uB}$ , where  $u$  is the usual narrow beam absorption coefficient and  $B$  is the buildup factor, is here replaced by the empirically determined expression,  $e^{-uB}$ .



Denoting the media steel and air by subscripts s and a,  $u = \mu_s z/h + \mu_a$  and  $-Ei$  represents the negative exponential integral. The symbol  $x_0$  is equal to  $\sqrt{h^2 + R_0^2}$ , where  $R_0$  is the radius of a circular plate giving the same value of  $I$  as the rectangular plate.

The first term in Equation B.21 represents the dose rate from an infinite plate, and the second term represents the dose rate from beyond the limits of the finite rectangular plate. Their difference therefore gives the dose rate from sources distributed over the plate itself.

B.3.2 Evaluation of the Shielding Factor. For compartments below the weather deck, where the weather deck is considered as the only surface on which contamination is deposited, the shielding factor for deposited activity is given by:

$$F_s = \frac{I_h}{I_3}, \quad (\text{B.22})$$

where  $I_h$  is the dose rate at distance  $h$  below the weather deck and  $I_3$  is the dose rate 3 ft above the deck.

Equation B.22 can be evaluated from Equation B.21 if the decks and intervening air are considered to be the only attenuating media. The calculations presented in the text have assumed that the contaminated area can be approximated by a square of the width of the deck, in which case  $R_0$  is approximately equal to the radius of a circle of equivalent area. Also, the apparent absorption coefficient for air,  $\mu_a$ , has been approximated by multiplying  $\mu_s$  by the ratio of the density of air to that of steel.

## Appendix C

# SUPPLEMENTARY MATERIAL ON SHIP DECONTAMINATION

### C.1 PROTECTIVE COATINGS

C.1.1 History. In December of 1952, the Mare Island Paint Laboratory was contacted in regard to developing a removable paint which would be temperature sensitive and easily washed off with a high-pressure stream of hot water. Approximately 6 months later, several samples of water emulsion paint were received at NRDL, and laboratory tests were started on both contaminated and uncontaminated samples. During the next 5 months, many variations of the original formula were tested. It was found that 90 percent or more of the contaminant was removed in the process of removing the paint. A composition was selected for further study which could be removed with a stream of water from a hot-liquid-jet unit at approximately 180°F and 200 psig at a rate of 4 to 5 sq ft/min. This paint was identified as Radiological Protective Coating, Formula 980, and 300 gal were prepared by Mare Island for evaluation on the test ships at Operation Castle. Although this paint could be made in any shade from white to black, a dark gray was selected so its removal could be easily followed.

In May 1953, BuShips Code 588 forwarded to NRDL a sample of a waste product from the Sun Oil Company via Sellers Injector Corporation to be evaluated as a hot-water-sensitive coating for ships. The material was entirely unsatisfactory as received, so Code 588 requested the Paint Laboratory at the Philadelphia Naval Shipyard to formulate a paint from this base that would meet the specifications. Subsequently, a sample of the new composition was shipped to NRDL for evaluation. It was recommended that this paint be removed by educting kerosene or other mineral spirits with the hot-liquid-jet units. This formulation was very difficult to remove, and it was impossible to remove more than 40 to 50 percent of the paint with prolonged hot-liquid-jet flushing. Since this paint represented a type different from the water-emulsion paint, 50 gal were shipped to the test site for limited testing.

C.1.2 Objectives. The objectives of the protective coating study were to determine the effectiveness of a removable protective coating as an aid in the recovery of ships contaminated by fallout from a nuclear detonation and to evaluate specific formulations of hot-water-sensitive-emulsion paints and solvent or oil-base hot-water-sensitive coatings in the above application.

C.1.3 Procedure. The starboard gun tubs on both the YAG 39 and YAG 40 were painted with an oil-base paint<sup>1</sup> and 90 percent of the

<sup>1</sup> Sellers Injector Corp., Formula X-80593-gray.

remainder of Section 3 on both ships was painted with the water-emulsion paint (Formula 980) as shown in Figure C.1.

Upon return of the test ships from the forward area after Shot 2, tests were made on the only slightly active YAG 39 to determine the removability of the protective coatings. It was found that the oil-base

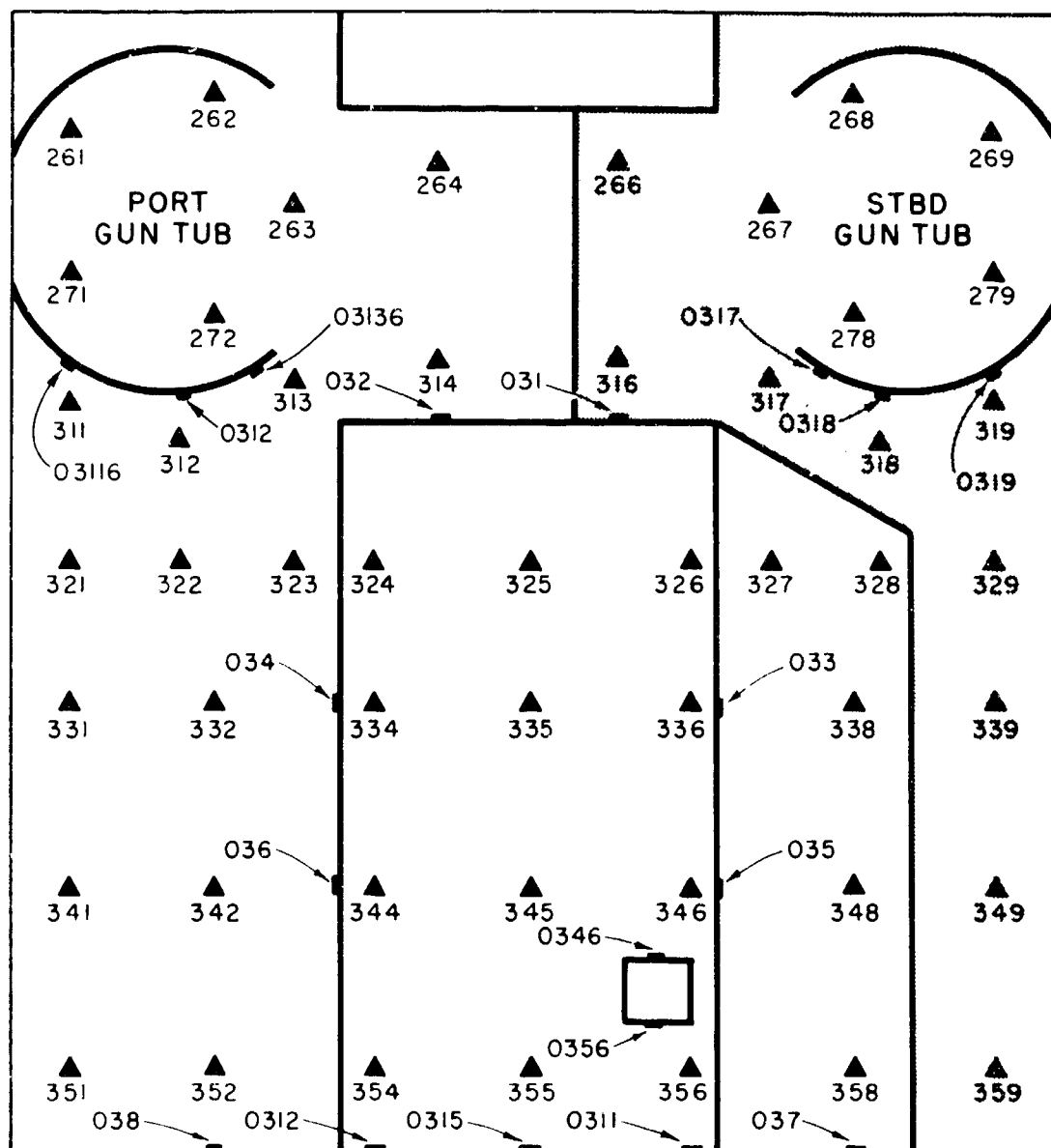

Note All weather surfaces painted with water emulsion paint (Formula 980) except shaded area. Starboard gun tub painted with oil-based paint.

Figure C.1 Plan view of section 3, YAG 40 showing areas of protective paint and monitoring stations.

paint could not be removed by the hot-liquid jet, even by soaking for 15 to 20 min in kerosene. The water-emulsion paint was relatively easy to remove from the horizontal surfaces with the 1250-gal/hr hot-liquid-jet unit but was very difficult to remove from the vertical surfaces and impossible to remove more than 50 to 60 percent of the paint by this method alone.

The following procedure was very effective in removing 90 to 95

percent of the water-emulsion paint from all surfaces: (1) the paint was sprayed with very dilute caustic solution (approximately 2 percent commercial grade NaOH); (2) this was allowed to soak into the surface approximately 5 to 15 min; and (3) the surface was flushed with a 1½-in. firehose at a rate of approximately 100 sq ft/min.

This procedure was used to remove the paint from Zone 3 of the highly contaminated YAG 40, but it would not loosen the oil-base paint from the starboard gun tub. Three teams of eight men each were used alternately. Each team consisted of one caustic sprayer, two 1½-in. firehose operators, five hot-liquid-jet operators (two on each unit, and one to help with hoses and assist the caustic sprayer). Supporting the three teams were two hot-liquid-jet control operators, two caustic mixers, one team coordinator, and two NRDL supervisors, all aboard the YAG 39. The operating schedule for each team is shown in Figure C.2.

The total area of Section 3, approximately 5,200 sq ft, required

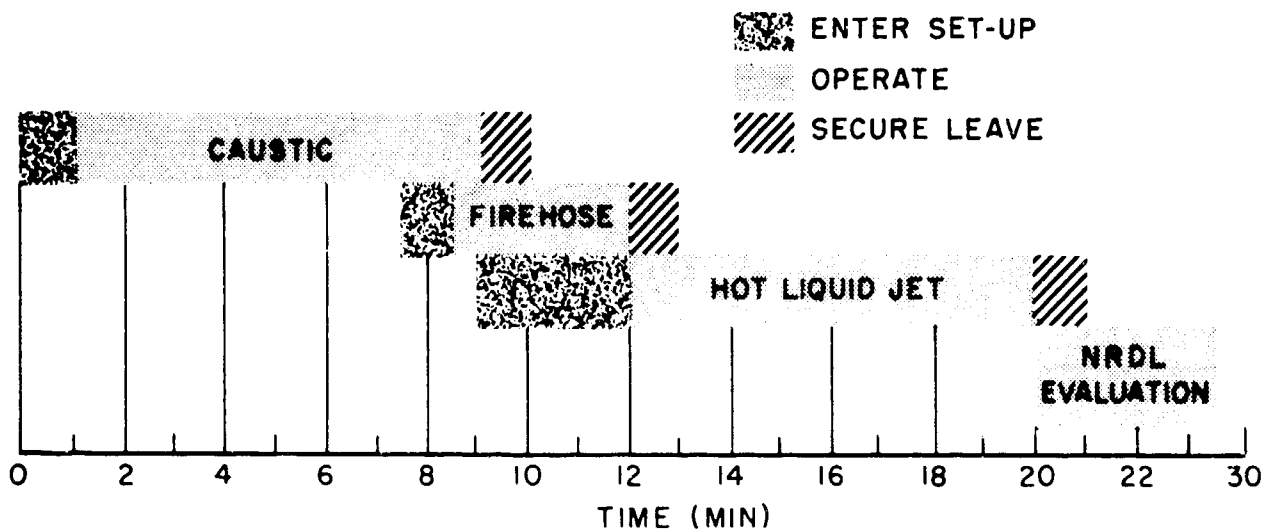

Figure C.2 Operating schedule for the teams removing the paint from the YAG 40 after Shot 2.

12 operating periods of 23½ min each to complete the decontamination.

Prior to the participation in Shot 4 all of the weather surfaces of the YAG 40, with the exception of the flying bridge, aft deck house, and the hull, were painted with the water-emulsion paint. This paint was thinned with fresh water in the volume ratio of 1 part water to 4 parts paint and applied by spraying to all of the surfaces, except the wood planking of the boat deck and the flight deck. It was applied to these two surfaces with swabs. Approximately 75 percent of the boat deck had been resurfaced with a powered rotary wire brush, and the paint was applied directly to the bare wood.

The YAG 40 was not decontaminated until after Shot 5, because only an insignificant amount of activity was present from the preceding shot. The decontamination was operational rather than experimental. It was considered impractical to attempt to remove the paint with the hot-liquid jet alone and the caustic soda procedure was begun immediately.

The general method used to reduce the radiation level and remove the paint was: (1) firehose; (2) allow to dry; (3) apply caustic solution; (4) firehose. The initial firehosing, done with a 1½-in. fog nozzle

firehosed initially, then each section was treated as a unit for paint stripping. A 5 percent solution of caustic in seawater was applied to the decks with swabs and a 10 percent solution was sprayed on the using a solid stream, was intended to remove loose activity and hold recontamination to a minimum. The surface had to dry before caustic application because the caustic solution would not penetrate the water film and effectively attack the coating beneath. The whole ship was bulkheads with a gasoline engine-driven sprayer. The removable paint was then stripped with a 1½-in. fog nozzle using the solid stream and flushed overboard. The main deck passage on either side of the superstructure companionways, however, were flushed with a Sellers 6,000 gal/hr hot-liquid-jet unit.

The paint stripping operation took 5 days to complete. The teams were setup similarly to those described for the stripping operation following Shot 2, except that usually three teams operated simultaneously

#### C.1.4 Results and Discussion.

C.1.4.1 Application of Paint. The water-emulsion paint (Formula 980), as received, was found to be very difficult to apply with the available spray equipment without throwing out large chunks, which resulted in buildup of a thick layer. It was found that a heavy layer was very difficult to remove. A layer of 1 to 2 mils was most desirable. The paint was thinned with fresh water in the volume proportion of one water to four paint, before applying by spray. In many places the vertical surfaces showed run streaks. The paint dried tack free in about 1 hr to a dark gray, almost black color. From 6 to 8 hr was required for the paint to take a permanent set. The oil base paint was applied by brush and appeared to have brushing qualities equal to that of any other good grade of paint. This paint dried tack free in approximately 4 hr and set to a yellow gray layer in approximately 12 hr.

C.1.4.2 Durability. A few hours after painting the test ships for participation in Shot 1, a considerable amount of rain fell, which resulted in loosening much of the water-emulsion paint on the horizontal surfaces. The vertical surfaces appeared to be unharmed, as were the surfaces covered with the oil-base paint.

The deck surfaces covered with the water-emulsion paint were slippery when wet, and heavy traffic over these areas loosened the paint, which was washed away by the rain. However, it was observed, that after the paint had been given sufficient time to set prior to wetting, it offered much more resistance to wear. When dry, this paint was not slippery; but it did scuff rather easily, and in its present form could not be considered for use on ship decks.

C.1.4.3 Removal of Paint. In the preliminary tests on the YAG 39 after Shot 2, it was found that the 1,250-gal/hr hot-liquid-jet cleaning unit removed only 60 to 80 percent of the water-emulsion paint from the vertical surfaces, all of the paint could be removed at a rate of approximately 20 sq ft/min with the same jet unit.

The procedure followed in the decontamination of Section 3 of YAG 40 resulted in removal of approximately 95 percent of the paint. The fire-hosing operations after pre-treatment with dilute caustic removed between

40 to 70 percent of the paint, with 95 percent of the rest being removed by the hot-liquid-jet operation. The total operating rate for the complete process was 320 sq ft/man-hr.

The water-emulsion paint made it possible to analyze the effectiveness of the 1,250-gal/hr hot-liquid-jet cleaning unit. It was observed that this jet unit made a path only 1 to 1½ in. wide at normal distance from the surface. When operating at the customary speed, a zig-zag path resulted, with only approximately 25 percent area coverage. It became evident from these tests that the 1,250-gal/hr jet with the nozzle used is inadequate for a large-scale paint-stripping operation.

C.1.4.4 Effectiveness. A summary of the gamma and beta reading before and after decontamination of Section 3 of the YAG 40 after Shot 2 are given in Table C.1. The removal of the water-emulsion paint showed a reduction in gamma level of from 60 to 90 percent with an average of 78 percent. The beta survey showed a reduction of 52 to 98 percent with an average of 84 percent. The same decontamination process on an adjacent unprotected area showed a reduction of 50 to 60 percent with an average of 55 percent removal of the contaminant.

The oil-base protective paint which could not be removed, was found to be slightly more difficult to decontaminate than standard Navy paint. The gamma survey showed a removal of 49 percent of the contaminant.

It is believed that the effectiveness of the protective coating could be increased by making a special effort to avoid recontamination during the decontamination operation. This could be partially accomplished by working from the top down and flushing the decontaminated surfaces with water when there is a possibility of recontamination from an adjacent, not-yet-decontaminated area.

In removing the protective coating after Shot 5, the repeated applications of caustic soda in high concentrations removed much of the 5H Haze Gray paint and even some of the red-lead primer. Such severe treatment would not be required to remove the protective coating, if the caustic soda could have been retained on the vertical surfaces long enough to react with the coating. The rapid runoff made necessary repeated applications; higher concentrations were used in hope of increasing the removal rate.

The removal was not uniform because of the lack of control over the reaction. In some places all of the paint, including Haze Gray and red-lead primer was stripped to the bare metal; in other spots parts of the protective coating remained. It is believed that this irregular stripping lowered the decontamination efficiency because of the extensive recontamination, as well as the faulty removal.

C.1.5 Conclusions. The experimental results show that the selected radiological protective coatings tested are unsatisfactory for service use, but the emulsion coating (Formula 980) demonstrated the soundness of the basic theory of a removable protective coating in the decontamination of a ship.

The hot-liquid-jet cleaning unit and nozzle combination used will give adequate coverage when operating at the required distances and desired rate of surface coverage.

The following specific conclusions can be made regarding the two paints tested.

TABLE C.1 RADIOLOGICAL PROTECTIVE COATINGS  
SUMMARY OF DATA, SHOT 2

Location	Station	Gamma - mr/hr				Beta MC			
		Before	After	% Resid.	Avg. % Resid.	Before	After	% Resid.	Avg. % Resid.
WATER EMULSION PAINT									
Port	264	600	100	16.7		1430	73	5.1	
Side	311	600	80	13.3		2900	240	8.3	
Deck	312	600	80	13.3		2000	220	11.0	
	313	600	80	13.3		1450	73	5.0	
	314	420	80	19.1		1050	88	8.4	
	321	600	80	13.3		2900	240	8.3	
	322	600	60	10.0		1220	130	10.7	
	323	500	80	16.0		1400	240	17.1	
	331	800	100	12.5		1630	150	9.2	
	332	600	100	16.7		2080	41	2.0	
	341	500	80	16.0		2080	97	4.7	
	342	500	80	16.0		2020	65	3.2	
	351	410	100	24.4		1250	105	8.4	
	352	460	80	17.4		1150	41	3.6	
Port	261	380	80	23.5		1220	97	80.0	
Side	262	360	80	22.2		980	100	10.2	
Gun Tub	263	440	100	22.7		1180	100	9.3	
	271	600	100	16.7		1630	220	13.5	
	272	460	120	26.1		1510	150	9.9	
Vent	324	800	140	17.5		2600	180	6.9	
House	325	800	180	22.6		1140	260	22.8	
	326	440	170	38.6		1050	57	5.4	
	334	800	180	22.5		1040	130	12.5	
	335	800	180	22.5		1900	125	6.6	
	336	600	170	28.3		1000	140	14.0	
	344	800	160	20.0		1750	120	6.9	
	345	700	190	27.2		860	200	23.3	
	346	800	200	25.0		240	260	108.3	
	354	800	120	15.0		280	160	57.2	
	355	800	120	15.0		2900	180	6.2	
	356	800	140	17.5		860	68	7.7	
Starboard	327	260	90	34.6		570	110	19.3	
Deck	328	240	100	41.7		420	200	47.6	
	338	270	110	40.7		320	120	37.5	
	348	340	120	35.3		420	82	19.5	
	358	500	150	27.3	21.7	830	330	39.8	
Vertical	031					280	42	15.0	
Sections	032					400	45	11.3	
	034					143	20	14.0	
	035					2600	105	4.0	
	036					60	26	43.3	
	037					380	42	11.1	
	0311					480	42	8.8	
	0312					380	52	13.7	16.3
OIL BASE REMOVABLE PAINT									
Starboard	267	200	80	40.		250	130	57.0	
Gun Tub	268	140	80	57.2		250	140	76.0	
	269	160	90	50.0		200	180	90.0	
	278	210	100	47.6		330	400	-	
	279	200	120	60.0		290	240	82.0	76.5
S-H HAZE GRAY PAINT (UNPROTECTED)									
Starboard	318	220	100	45.5		360	250	69.5	
Deck	319	240	100	41.7		470	240	51.0	
	329	220	100	45.5		360	290	80.5	
	339	340	160	47.1		420	230	54.0	
	349	320	160	50.		360	230	63.9	
	359	450	180	40.0	45.0	570	560	98.3	69.7

#### Mare Island Formula 980.

This paint can only be removed effectively after treatment with a mild caustic solution.

A total of 90 to 95 percent of the paint is removable after caustic treatment at a nominal rate of 20 sq ft/min and will remove 75 to 90 percent of the radioactive contaminant present.

#### Sellers Formula X-80593 Gray.

This paint is unsatisfactory for use as a removable protective coating, because it is no easier to remove than standard Navy paint and is no less difficult to decontaminate.

#### Caustic Treatment.

This treatment is an effective method of stripping paint on horizontal surfaces and also on vertical surfaces if the solution can be retained on the surface long enough to react.

C.1.6 Recommendations. The program to develop a removable radiological-protective coating which will conform to the following specifications should be continued. The coating should: (1) be easily applied over Navy 116-5H paint system by either brush or spray; (2) set sufficiently within 2 hr after application that it will be unaffected by rain or salt water spray and after 4 hr be sufficiently set on horizontal surfaces that they can be walked on; (3) withstand flushing with 250 gpm of water at a distance of 6 inches and a nozzle temperature and pressure of 140°F and 35 psi, respectively; (4) withstand radiant heating up to temperatures of 140°F without detectable change; (5) be removable at a rate of 50 to 100 sq ft/min using 20 gpm of water at a distance of 6 to 12 in. and a nozzle temperature and pressure of 170°F and 150 psig; (6) withstand normal service use for 3 to 6 months; (7) fulfill removal requirements 6 to 12 months after application; and (8) permit visual determination of the progress of removal.

A protective coating system that involves two easily removable coatings and is applied over the standard Navy paint should be developed. The top layer should be removable with a stream of hot water and the lower layer should be removed with a special solvent or weak alkali solution. It is conceivable that such a system would make possible 90 to 95 percent removal, after which the ships could be returned to a shipyard where the second protective coating could be rapidly removed in the industrial decontamination operation.

Studies to improve the effectiveness of the hot-liquid-jet cleaning unit for removing hot-water-sensitive coatings should be started.

Procedures for removal of standard Navy paint with viscous or thickened paint-stripping solutions should be developed.

## C.2 GAMMA-DOSE-RATE CURVES

Curves showing the reduction in the average gamma dose rate on deck due to the combined effects of decontamination and decay are given in Figures C.3 through C.5. The end points of the curves were found from initial and final surveys which included the entire ship. Such complete surveys permitted the computation of the mean value from the sum of the individual readings.



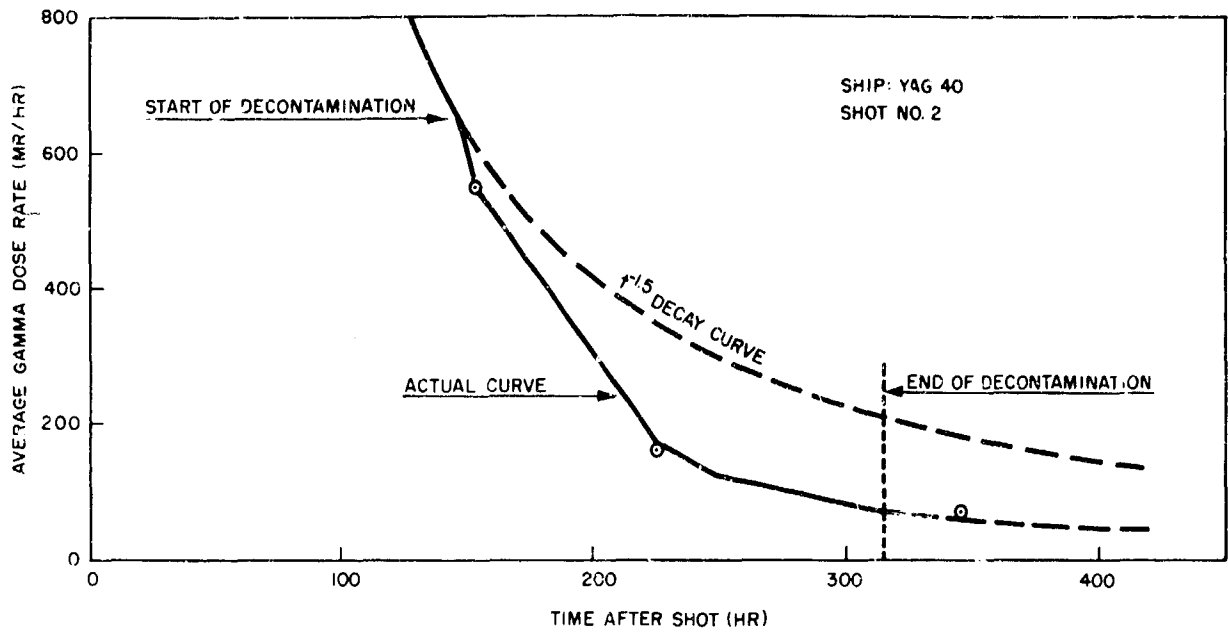

Figure C.3 Average gamma dose rate aboard YAG 40 as a function of time after Shot 2.

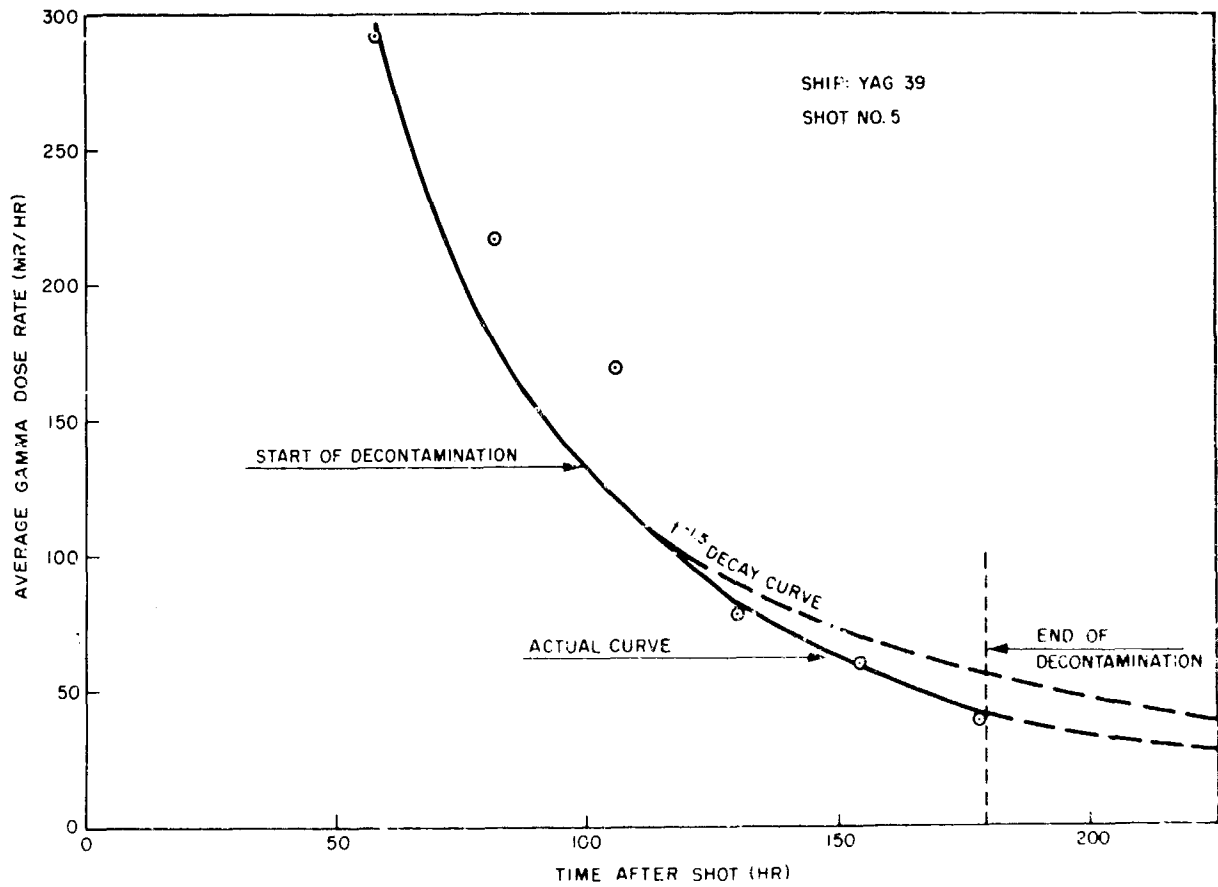

Figure C.4 Average gamma dose rate aboard YAG 39 as a function of time after Shot 5.

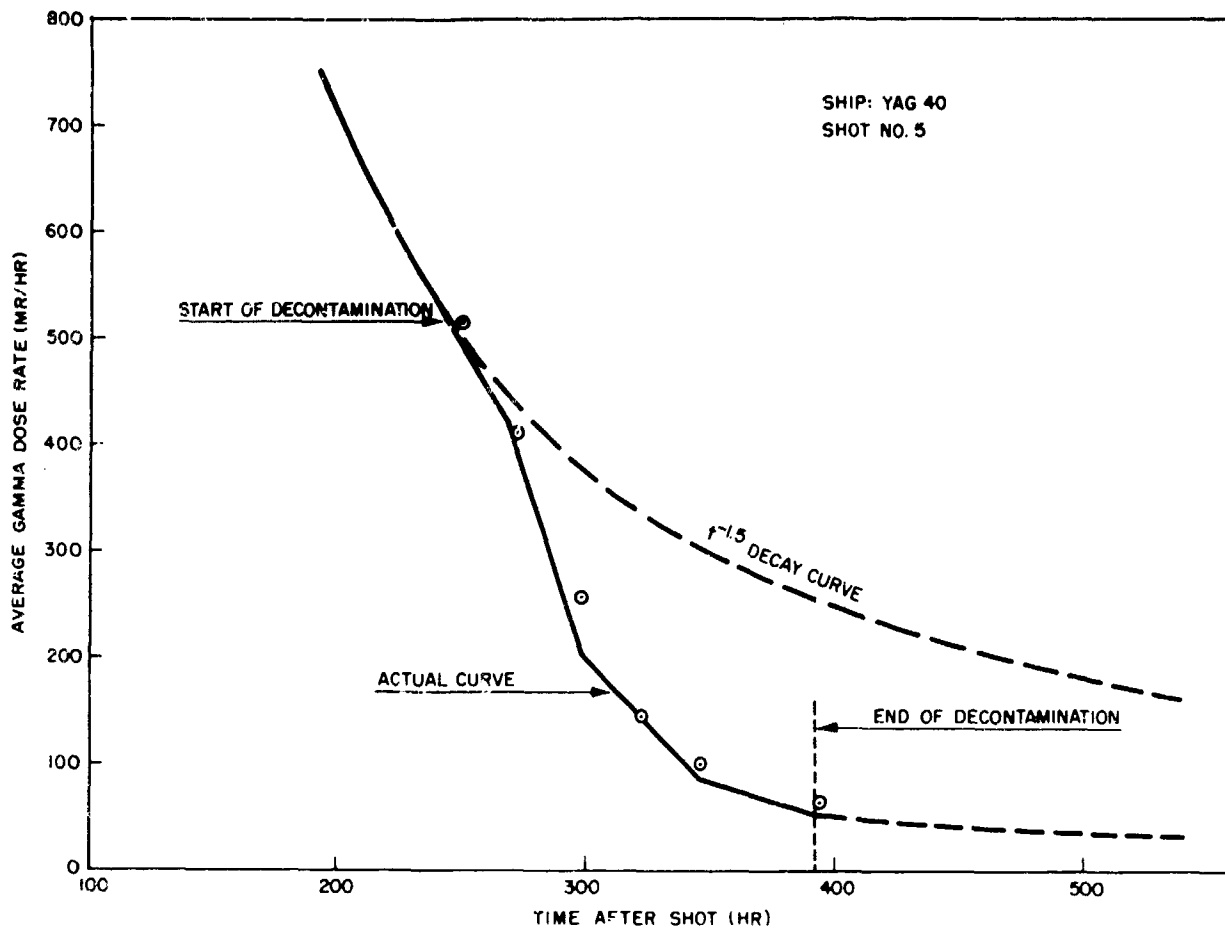

Figure C.5 Average gamma dose rate aboard YAG 40 as a function of time after Shot 5.

However, it was not always possible to establish the value of intermediate points on the curves by this same direct method. This was due to the fact that the intermediate surveys covered only those sections of the ship selected for a particular decontamination operation.

C.2.1 Method of Determination. To compute the average shipboard level after surveying only a portion of the deck, it was necessary to make decay corrections to the readings taken from the rest of the ship prior to decontamination. A theoretical  $t^{-1.5}$  gamma-decay law was employed in adjusting these readings to a common time. The -1.5 exponent was determined from data collected during Operation Castle (Reference 6).

Because of the immediate need of a decay law in processing the test data, the -1.5 exponent was offered as a nominal value and was restricted to the interval from 3 days to 16 days after shot time. It was not expected to agree exactly with the final value reported in the above references, since subsequent corrections increased the precision of the earlier estimate.

The fact that the  $t^{-1.5}$  law very nearly follows the decay law observed aboard the ships is borne out by Figures C.3 through C.5. The solid curve shown in each of those figures connects points which have

been adjusted for decay. The circled points show average shipboard levels compiled independently by Radiological Safety personnel from separate survey data. Although these values need no decay correction, the circled points fall extremely close to the decay-corrected solid curve. This tends to substantiate the validity of the  $t^{-1.5}$  law.

Table C.2 demonstrates the procedure for calculating the points for

TABLE C.2 COMPUTATION OF THE GAMMA DECAY CURVE FOR THE YAG 39 AFTER SHOT 5

Column Number		1	2	3	4	5	6
Identity of Entry		No. of Stations	No. of Readings	Decay Correction Factor	Total Readings per Section	Wt'd Total per Section	Wt'd Avg. for Ship (mr/hr)
Computation						$\frac{1 \times 3 \times 4}{2}$	5/1
Time after Shot Days	Hours	Section					
Y+3	76	1	47	47	1.0	6155	6155
		2	57	57	1.0	11860	11860
		3	50	50	1.0	14040	14040
		4	68	68	1.0	12440	12440
		5	72	72	1.0	15980	15980
		6	36	36	1.0	5270	5270
			330			65745	199
Y+5	130	1	47	37	1.0	2564	3260
		4	68	31	1.0	2353	5170
		5	72	31	1.0	2232	5180
		6	36	21	1.0	1129	1940
		2	57	57	0.447	11860	5300
		3	50	50	0.447	14040	1280
			330			27130	82
Y+6	154	1	47	47	1.0	1650	1650
		3	50	45	1.0	3930	4370
		5	72	72	0.951	4021	3820
		2	57	57	0.346	11860	4100
		4	68	68	0.775	5170	4010
		6	36	36	0.775	1940	1500
			330			19450	59
Y+7	179	1	47	21	1.0	814	1820
		2	57	45	1.0	1737	2200
		3	50	50	1.0	2398	2400
		4 WH	26	26	1.0	1440	1440
		4 BD	42	16	0.623	868	1420
		5	72	72	0.766	4021	3040
			330			1210	41
						13530	

the solid curve shown in Figure C.4 for YAG 39 after Shot 5. Totals for the initial survey at 76 hr after shot time are shown. Column 2 lists the number of readings taken in each section, and Column 4 lists the summation of these measurements within each section. Computation of a single average dose rate for the entire ship is dependent upon uniformly distributed survey readings. Therefore, within a given section the number of readings should be proportional to the area of that section. Where this was not the case, section totals in Column 4 were weighted by the ratio of number of stations to the number of readings, inasmuch as the station density over the whole ship was relatively constant. The average shipboard level of 199 mr/hr in Column 6 was found by dividing the total

count for the whole ship by the total number of stations read.

$$65745/330 = 199 \text{ mr/hr.}$$

At 130 hr, the table indicates that Sections 1, 4, 5, and 6 have been recently decontaminated, since the decay factor in Column 3 for each of these areas is unity.

The summation of readings per section is adjusted in Column 5 by multiplying the value in Column 4 by the number of available survey stations in Column 1 and dividing by the number of readings actually taken in Column 2. For Section 1 this calculation is

$$47/37 (2564) = 3260.$$

Readings in Sections 2 and 3 were decayed from 76 hr to 130 hr after shot time, since these two areas were not decontaminated and surveyed along with the other four sections. Values in Column 4 were multiplied by the decay factors in Column 3. For Section 2 the calculation is

$$0.447 (11860) = 5300$$

The corrected summations of readings for each section were then totaled and entered in Column 5. This was in turn divided by the number of stations to obtain the average shipboard level of 130 hours.

$$27130/330 = 82 \text{ mr/hr.}$$

A similar procedure was followed for survey times of 154 hr and 179 hr, and the values are shown in the table.

### C.3 DETERMINATION OF CONFIDENCE INTERVALS

C.3.1 Method. To bracket the true mean values of initial contaminant remaining, the 95-percent confidence limits were computed from the data obtained during the tactical decontamination studies aboard YAG 40 after Shot 2.

These limits were determined in the customary manner using the equation:

$$X = \bar{x} \pm \frac{st}{n} \text{ where}$$

X = mean value of samples

s = an unbiased estimate of the standard deviation

n = number of samples

t = the percentage point of the t distribution for n-1 degrees of freedom and for 0.05 confidence level.

The value of s in the above equation was computed by the technique described (Reference 24). Table C.3 demonstrates this technique.

Since the frequency distribution of values for percent of initial contamination remaining has not been established, it was assumed that the

TABLE C.3 PROCEDURE "B" ON BOAT DECK

Column Number	1	2	3	4	5	6	7	8
Identity of Entry	Initial Contam.	Final Contam.	% Resid'l Contam.	Column 3 Scrambled	Max.	Min.	Range	Sum of Ranges
Day and Time of Count	R+9 1600	R+10 1400						
Decay Correction			22 hrs 1.14					
Computation			$(114) \frac{2}{1}$				(5)-(6)	(7)
Station No.								
361	570	300	60	48				
362	230	100	50	36				
368	1040	450	49	48	80	27	53	53
369	1250	300	27	47				
421	570	400	80	27				
429	360	150	48	80				
432	570	250	50	46				
438	1250	400	36	44				
441	970	400	47	33				
449	860	350	46	31				
452	900	350	44	50	63	19	44	
458	2000	800	46	46				
461	905	350	44	44				
464	1040	300	33	63				
466	410	70	19	19				
469	310	125	46	40				
472	1100	300	31	26				
475	570	135	27	49				
478	410	145	40	49	60	26	34	78
491	780	175	26	27				
494	1500	650	49	50				
496	830	350	48	46				
499	450	250	63	60				
23		Total	1009					
		Mean	43.8					
	Group Size (a)		Coefficient (a)				Sum of Ranges	
	7		0.112 x 53 =				5.94	
	6		0.122 x 78 =				9.52	
			Unbiased estimate of Standard Deviation (s) =				15.46	

(a) Coefficients corresponding to the proper group size are listed in appropriate tables contained in reference (2).

sample values were from a normal population. This assumption, although required for employing the "t" distribution in computing the confidence limits, did not preclude the existence of a population distribution other than normal. However, since the means of the samples from most abnormal distributions tend to approximate a normal distribution for large sample sizes, the resultant error, if any, from the above assumption was not expected to be significant.

C.4 DAILY LOG OF DECONTAMINATION OPERATIONS

Shot 2  
YAG 40

<u>Date</u>	<u>Time after Shot</u> <u>Days</u> <u>Hours</u>	<u>Time of</u> <u>Day</u>	<u>No. of</u> <u>Men</u>	<u>Remarks</u>		
4/2/54	R+6	147	0930 (b)	12	Surveyed Sections 1 and 2 prior to FH Surveyed Sections 1 and 2 prior to HS(a) HLJ and FH flush Surveyed Sections 1 and 2	
		149				1130
		153				1530
4/3	R+7	172	1030	25	Surveyed Sections 5 and 6 FH Section 5 and 6S Surveyed Sections 5 and 6-HS(a) and FH flushed Sections 5 and 6S Surveyed Sections 5 and 6	
		176				1430
		178				1630
4/4	R+8	194	0830	23	Surveyed Sections 5 and 6 - Applied C-120 then HLJ and FH flushed Sections 5 and 6D Surveyed Sections 5 and 6	
		200				1430
----- Men transferred to protective coating studies from 1400 of 4th to 1400 of 5th -----						
4/5	R+9	219	0930	25	Surveyed Section 4 (wheel house) Applied C-120 then HLJ, HS(a) and HLJ Surveyed Section 4	
		224				1430
		226				1600
4/6	R+10	242	0830	26	HLJ-HS(a)-HLJ Section 4 (boat deck) HS(a) and FH flushed Section 4 (wheel house) Set up 6000 gal Sellers unit and turret nozzle.	
4/6	R+10	247	1330	26	Surveyed Sections 1, 2, and 3 Surveyed Sections 4, 5 and 6 6000 HLJ(a) Section 1	
		248				1430
4/7	R+11	267	0930	24	6000 HLJ(a) Section 2 6000 HLJ Section 3	
		271				1300
4/8	R+12	293	1130	19	Finished Sections 2 and 3 Started 6000 HLJ(a) Section 4 (boat deck)	
4/9	R+13	314	0830	21	Finished Section 4 (boat deck) Surveyed Sections 1, 2, 3 and 4 6000 HLJ(a) Sections 5 and 6	

(a) C-120 detergent added

(b) Times shown are averaged to nearest half hour.

Shot 2  
YAG 40 (Cont.)

Date	Time after Shot Days	Hours	Time of Day	No. of Men	Remarks
4/10/54	R+14	338	0830		Surveyed Sections 5 and 6
Shot 5 YAG 39					
5/8	Y+3	76	1000		Initial survey prior to decon
5/9	Y+4	99	0830	28	Small HLJ <sup>(a)</sup> Section 4 and 6000 HLJ <sup>(a)</sup> Sections 5 and 6
5/10	Y+5	123	0830	28	Surveyed Sections 4, 5 and 6 HS, repeated treatments from 1st pass and FH flushed Sections 4, 5 and 6
		123	0900		
		130	1600		
5/11	Y+6	146	0800	28	HS <sup>(a)</sup> , 6000 HLJ <sup>(a)</sup> and FH flushed Section 5
		149	1100		
		151	1300		
		154	1540		
5/12	Y+7	170	0800	28	6000 HLJ <sup>(a)</sup> Section 2, 3 and face of superstructure HS and small HLJ <sup>(a)</sup> aft portion of Section 1 CS, small HLJ <sup>(a)</sup> and FH flushed Section 4 (wheel house)
		179	1630		
Shot 5 YAG 40					
5/15	Y+10	244	0930		Initial Survey prior to decon
5/16	Y+11	268	0900	35	FH Section 1, 2, 3, 4 and 1/2 of 5 Surveyed Sections 1, 2, 3, 4 and 5 CS and FH Section 1 and 4 (wheel house)
		269	1030		
5/17	Y+12	290	0830	20	Surveyed Section 1 and 4 (wheel house) CS and FH sections 2, 3, 5, 6 and 4 (boat deck including port bulkhead)
		298	1600		

Shot 5  
YAG 40 (Cont.)

<u>Date</u>	<u>Time after Shot</u> <u>Days</u> <u>Hours</u>	<u>Time of</u> <u>Day</u>	<u>No. of</u> <u>Men</u>	<u>Remarks</u>
5/18/54	Y+13      314	0830	20	CS and FH Section 3 (including face of superstructure and gun tubs), section 4 (boat deck)
	322	1630		Surveyed Sections 3 and 4
5/19	Y+14      338	0830	20	CS and FH Section 4 (aft portion of boat deck, starboard bulkhead and gutters), section 5 (bulwarks, aft bulkhead of superstructure, mast house and No. 4 hatch combing), Section 6 (bulkheads of after deckhouse). CS and 6000 HLJ <sup>(a)</sup> companionways, Began CS and FH on stack
	346	1600		Surveyed all but wheel house
5/20	Y+15      362	0830	20	CS and FH Sections 5 and 6, Section 3 (fwd deck house, flying bridge and face of superstructure), Section 4 (stack and wheel house), and companionways. FH flushed Section 3 and companionways.
	369	1530		Surveyed Sections 3, 4, 5 and 6
5/21	Y+16      386	0900	18	Resurfaced boat deck and FH flushed wood chips off main deck
	393	1500		Surveyed entire ship.

C.5 PHOTOGRAPHS

Figures C.6 through C.16 are a series of photographs showing equipment and various phases of the ship decontamination studies.





Figure C.6 Forward deck area and flight deck as seen from bridge, YAG 39. Note numbered crosses fixing position of monitoring stations.

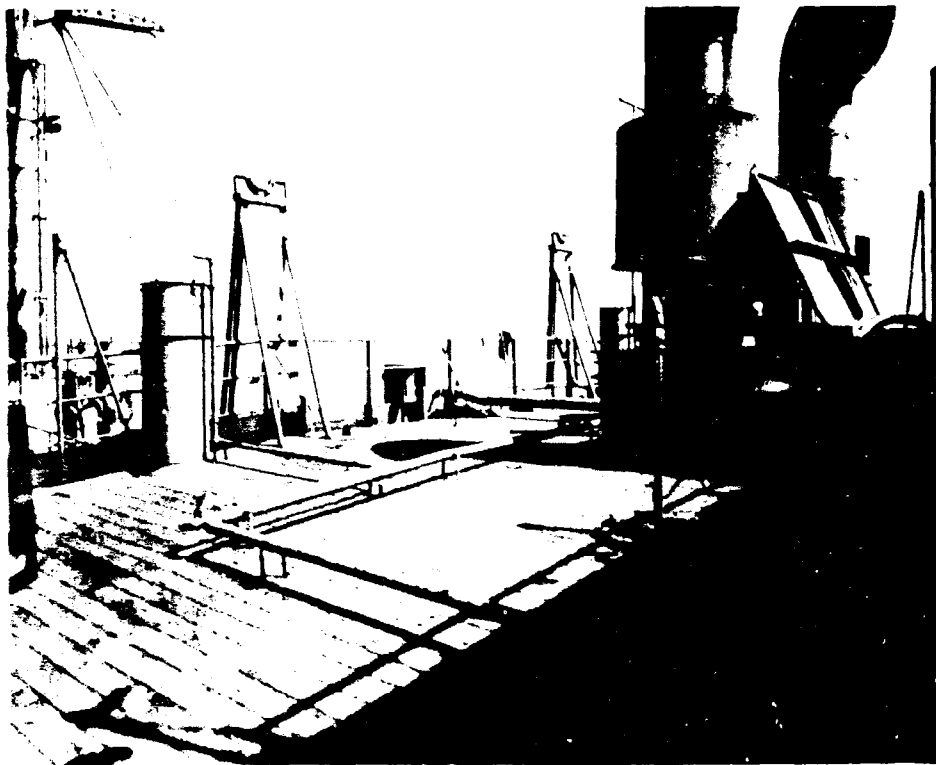

Figure C.7 Boat deck aft from starboard side, YAG 39.

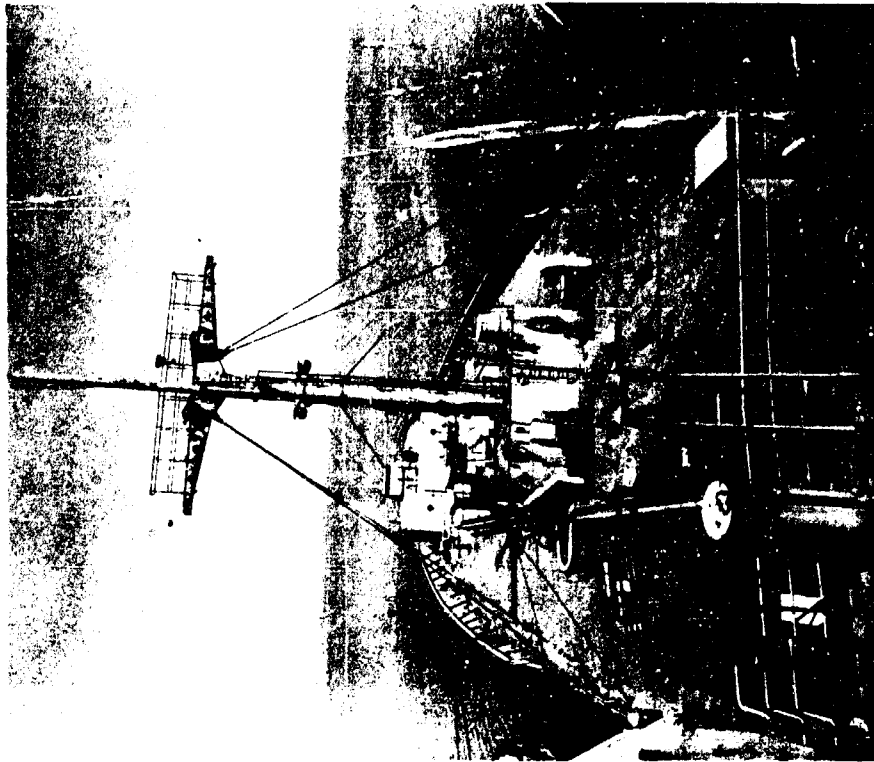

Figure C.9 Deck area looking aft from top of wheel house, YAG 39.

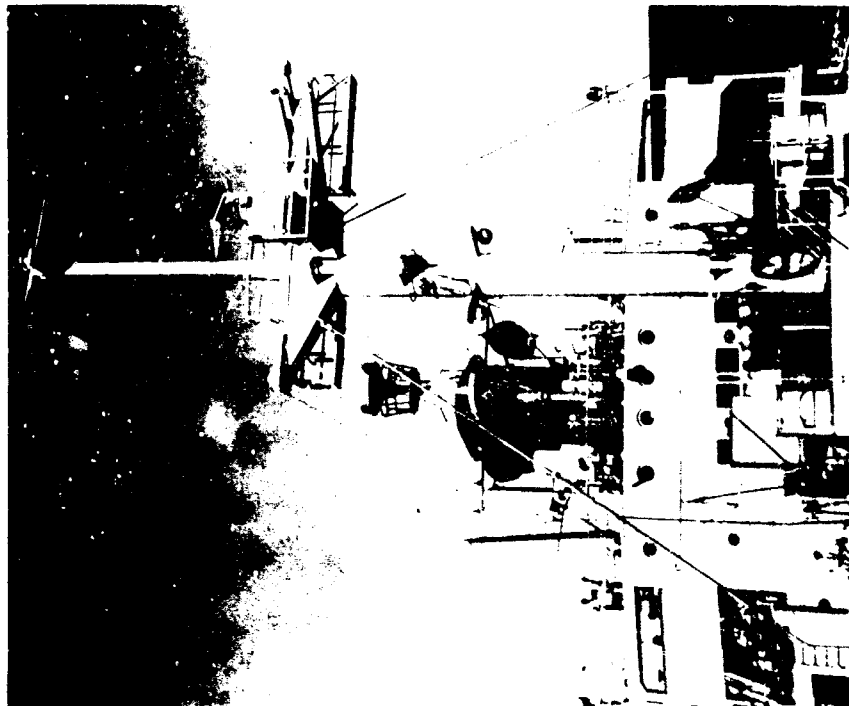

Figure C.8 Front of superstructure looking aft from flight deck, YAG 39.

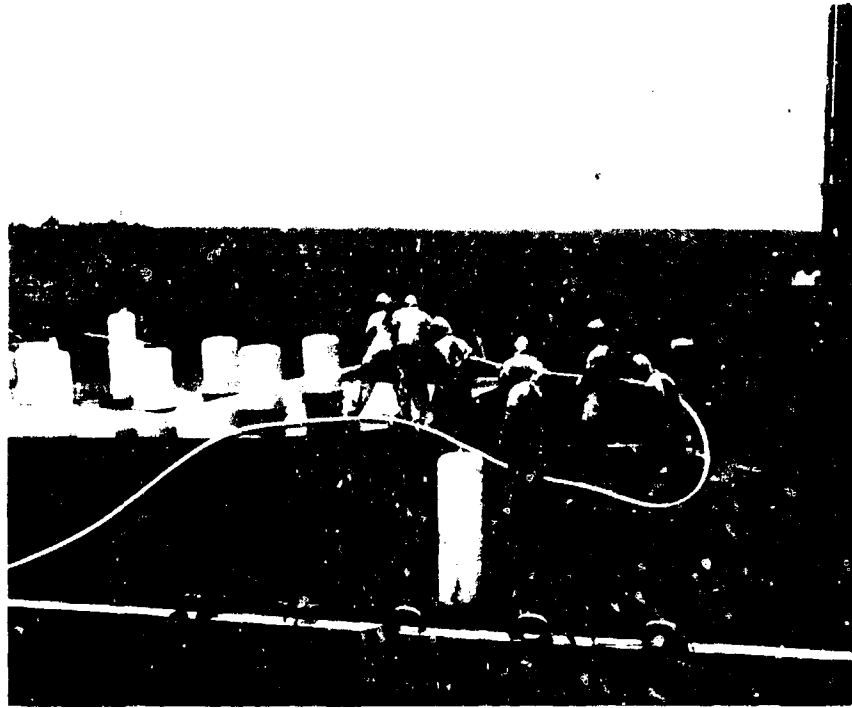

Figure C.10 Hose team washing deck of YAG 40 (Shot 2).  
Note plastic suits.



Figure C.11 Drum mounted 1250-gal/hr sellers unit and  
hand held delivery lance.

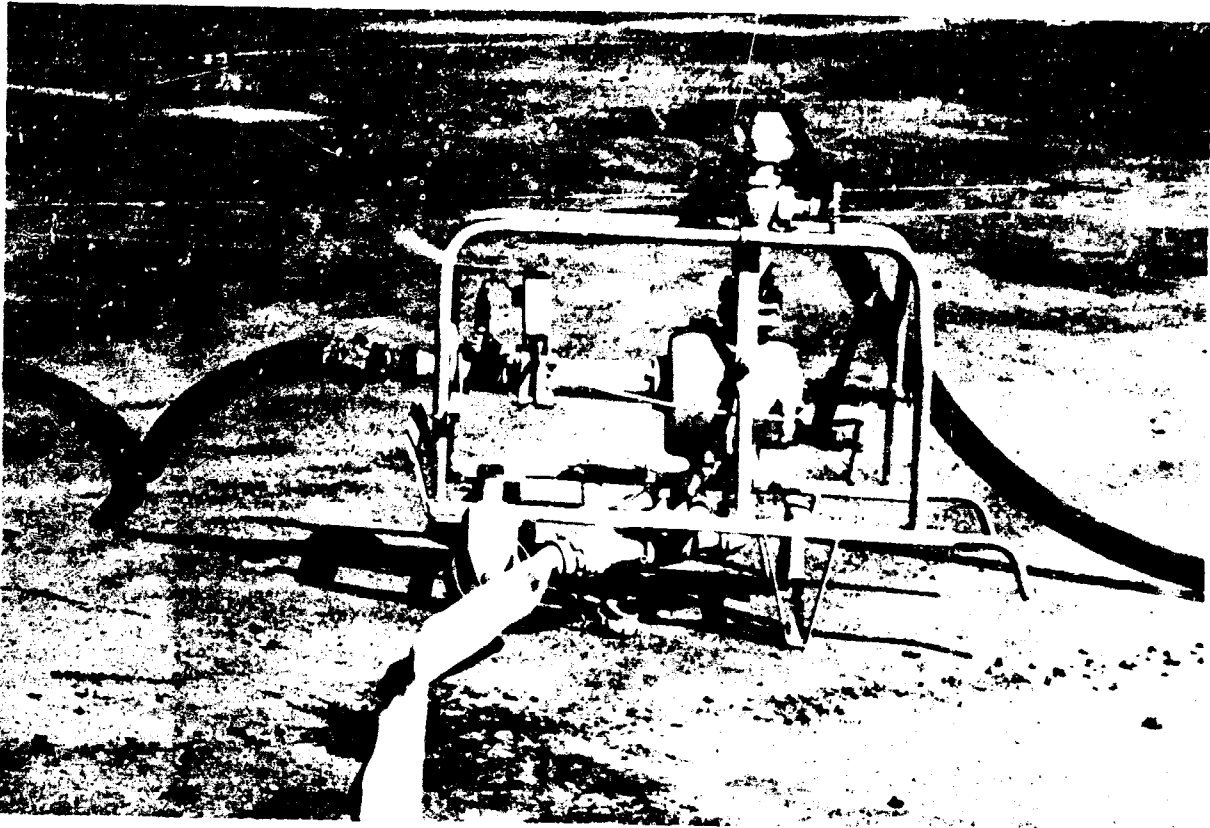

Figure C.12 The 6,000-gal/hr Sellers unit

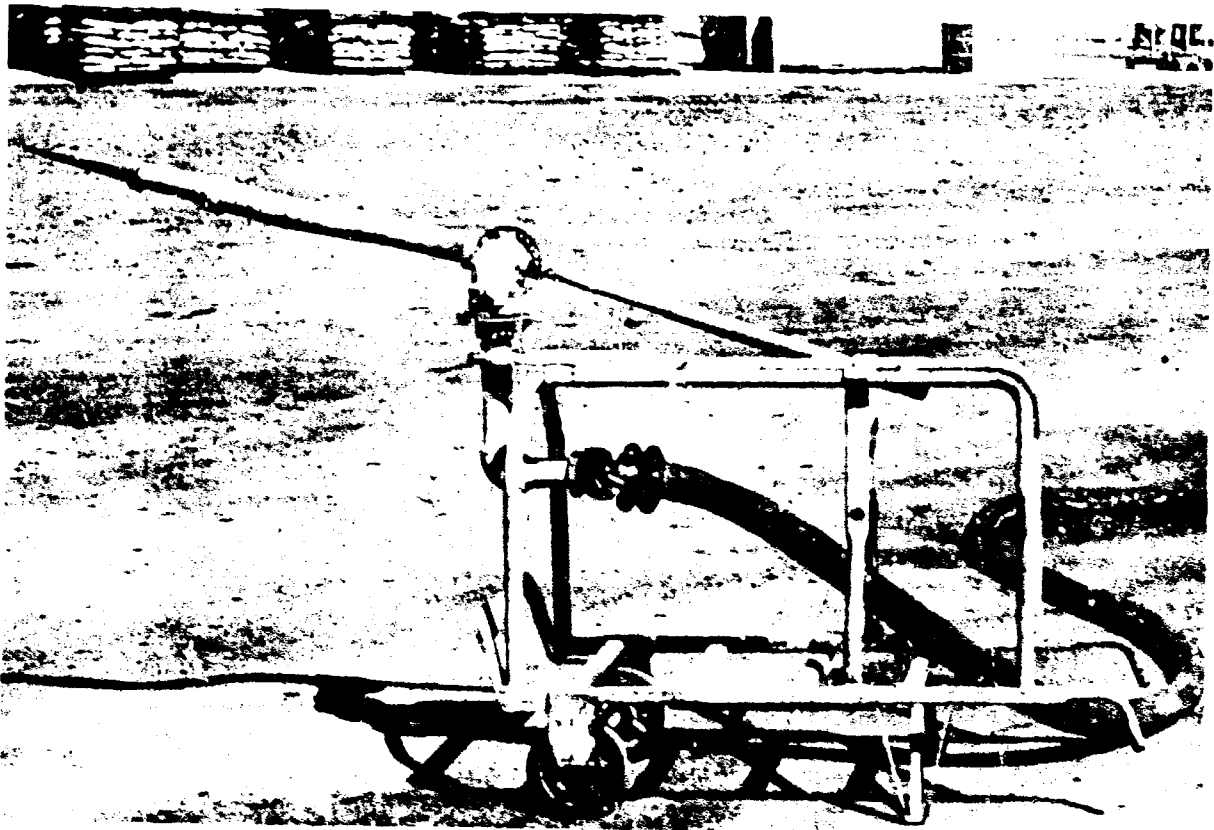

Figure C.13 Turret nozzle used in conjunction with 6,000 gal/hr Sellers unit

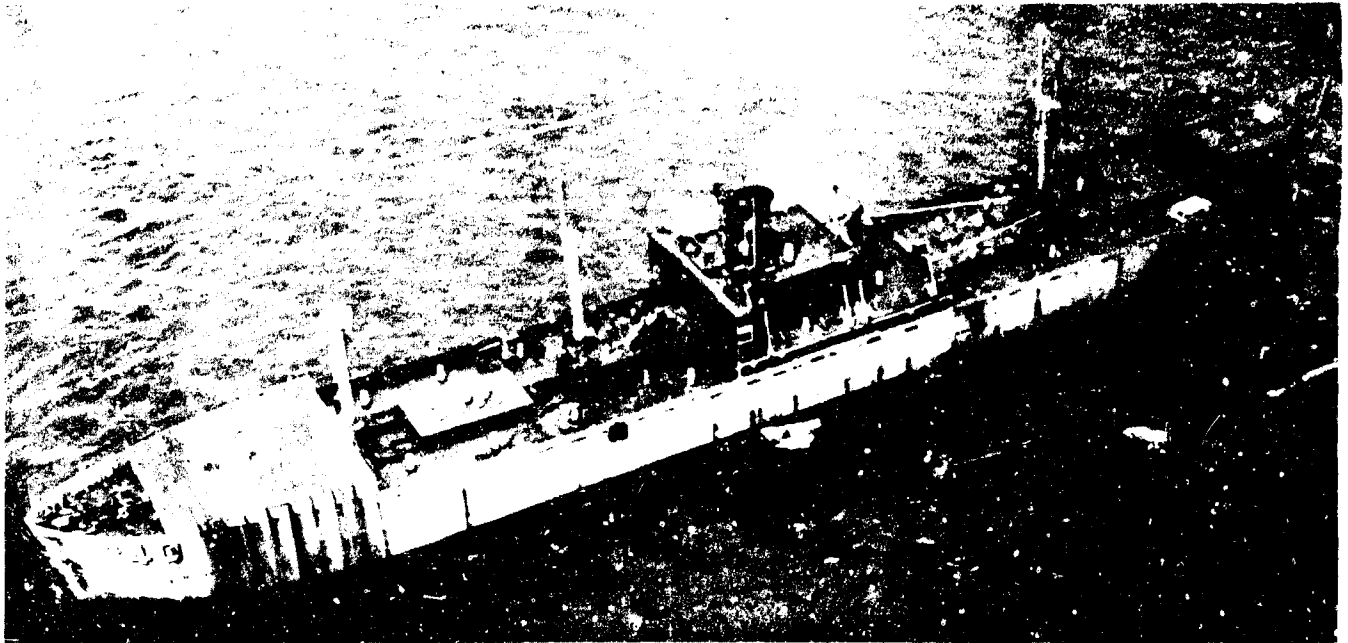

Figure C.14 YAG 40 showing Mare Island Formula 980 protective coating on decks and superstructures.

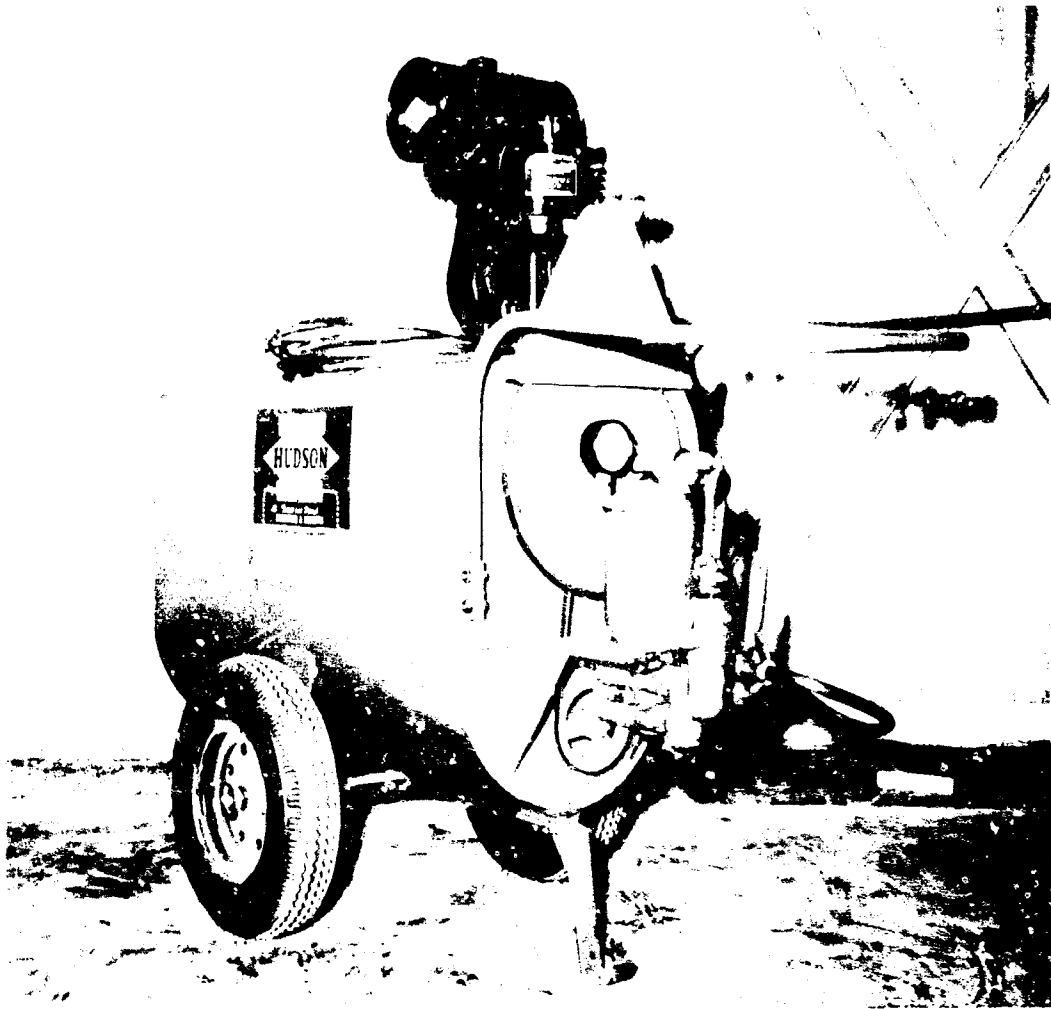

Figure C.15 Hudson portable spraying rig used in applying caustic paint stripping solution.



Figure C.16 Tennant floor machine and hand held Aurand resurfacing tool.

## Appendix D

# SUPPLEMENTARY MATERIAL ON AIRCRAFT WASHDOWN AND DECONTAMINATION

### D.1 CONSIDERATION OF SOME FACTORS AFFECTING DECONTAMINATION RESULTS

There are a number of uncontrollable variables that should be mentioned in discussing the decontamination effectiveness obtained from these tests. These variables made it impossible to have similar sets of conditions for all tests and should be kept in mind when comparing results. One is the initial level of contamination. No attempt has been made to compare the results on the basis of high or low initial contamination. However, the results obtained from the aircraft on the washdown ship are considered separately from the results obtained from the aircraft on the nonwashdown ship.

A second variable is the type of contaminant. Although all the shots were water-surface ones, Shot 2 was detonated in shallower water, and the fallout probably contained coral or bottom material, as evidenced by patches of a white chalky substance at various locations on the YAG 40 aircraft. It is not known whether this apparent difference in the content of the fallout affected its ease of removal or the effectiveness of the decontamination methods.

No attempt was made to correlate decontaminability versus time after shot; initial decontamination efforts on the different shots were begun at 54, 76, and 123 hr after shot time (see Table D.9). The data from this project did not indicate whether the time of decontamination after shot affected the ability to remove the contaminant.

On some days the beta and gamma survey readings were not taken either before or after a decontamination effort. In these cases a number was obtained by taking the last prior reading and decaying to the proper time through use of decay curves. If the missing readings were after a decontamination effort, the numbers were obtained by calculating the reverse decay from the following day's readings prior to decontamination.

The fixed gamma recorder, with its station in the cockpit of the aircraft, was started before any decontamination was begun and was run continuously until after the final decontamination was completed. This instrument gave a complete gamma record for each aircraft. Only the results from the aircraft aboard the YAG after Shots 2 and 5 were plotted, because the level of activity on the other shots was too low to warrant it.

No decay allowance was calculated for the initial decontamination operation on each aircraft, except in data from the fixed gamma recorder. For all decontamination calculations after that, the proper readings were decayed to the nearest half hour.

The full extent of the effects of the weather on the decontamination efforts is not known. Many showers and rainstorms between shot

times and the completion of the decontamination efforts undoubtedly washed off some of the contaminant. One rainstorm in particular occurred between Shot 2 and the initial decontamination effort and resulted in a 90-mr/hr (about 10-percent) reduction in dose rate on the fixed gamma recorder. The percentage of contaminant removed was not considered sufficient to change the classification of aircraft on the YAG 40 after Shot 2 from Condition A to Condition B. Other showers occurred before and between aircraft decontamination procedures but were not of sufficient intensity or duration to cause an easily identified reduction in dose rate on the fixed gamma recorder.

Other variables that probably affected the results were the personnel taking the readings and the survey instruments used. Most of the monitors were sailors who had been given a few hours instruction in a standardized technique of monitoring. Undoubtedly, some may have developed different techniques with the survey instruments which would give a variation in the readings. Also, since the survey instruments were used interchangeably during decontamination operations, even though they were calibrated periodically, this probably introduced a variable in the readings.

The painted surfaces on the aircraft were generally in fair to poor condition. The aircraft had previously been in service and were not specially painted or otherwise prepared for this operation. However, they had been treated with Type C preservative before being transported to the site, and it was necessary to use Gunk to remove this preservative. This cleaning with Gunk also removed the oil, grease, and industrial film usually found on operating aircraft, leaving an unusually clean surface. Ordinarily, this oil and grease would entrap a larger amount of contaminant than a clean surface, but the oil and grease plus the contaminant is removed by decontamination.

Thus, the poor condition of the paint on the aircraft was more than compensated for by the clean surface, and the decontamination results should be more effective under normal operating conditions. This conclusion is based on a comparison between the decontamination of the aircraft surfaces and the test plates with new unweathered surfaces, which indicated that fire hosing or hot-liquid-jet washing removed about the same percentage of contaminant in either case but that scrubbing with detergent or Gunk was more effective on the test plates than on the aircraft.

## D.2 COMPILATION OF FIELD DATA

D.2.1 Material Damage. Details of the material damage inspection are given in Tables D.1 through D.8.

D.2.2 Washdown Effectiveness. This section includes the detailed information (Figures D.1 through D.13) at early times ( $t_0$ ) of both the dose and the dose rate that was used, particularly in determining the washdown effectiveness. The information is corrected for the contamination ratios described in Chapter 2 when applicable.



TABLE D.1 MATERIAL DAMAGE INSPECTION PLAN AND RESULTS

Ship <u>YAG 39</u> Plane No. <u>81724</u> Shot <u>1</u>	
Date and Time of Inspection <u>23 Feb. (Before)---5 Mar. (After)</u>	
Material or Area Inspected	Findings
Engine Turnup Data (Before) <sup>(a)</sup>	Engine Turnup Data (After) <sup>(a)</sup>
1. RPM 1800	1. Similar to data taken (Before)
2. Cylinder Temperature 200°C	
3. Manifold Pressure 25 in.	Radio checked out
4. Oil Temperature 65°C	
5. Fuel Pressure 18 lb	
6. Oil Pressure 85 lb	Rust was evident on unpainted ferrous metals such as engine studs and wing locking pin housing. (Grease was removed from wing locking pin housing when aircraft was depressured.)
7. Voltage 27 v	
8. Hydraulic pressure 1000 lb	
9. Magneto Dropoff	
A. Left 30	
B. Right 40	
Radio checked out.	

(a) All readings taken at full-rich position.

TABLE D.2 MATERIAL DAMAGE INSPECTION PLAN AND RESULTS

Ship <u>YAG 40</u> Plane No. <u>81624</u> Shot <u>1</u>	
Date and Time of Inspection <u>23 Feb. (Before) and 5 Mar. (After)</u>	
Material or Area Inspected	Findings
Engine Turnup Data (Before) <sup>(a)</sup>	Engine Turnup Data (After) <sup>(a)</sup>
1. RPM 1800	1. Similar to data taken (Before) except that Cylinder Temp. was 150°C.
2. Cylinder Temperature 175°C	
3. Manifold Pressure 27 in.	Radio checked out.
4. Oil Temperature 85°C	
5. Fuel Pressure 16 lb	
6. Oil Pressure 88 lb	
7. Voltage 27-28 v	
8. Hydraulic Pressure 1100 lb	Rust was evident on unpainted ferrous metals such as engine studs and wing locking pin housing. (Grease was removed from wing locking pin housing when aircraft was depressured.)
9. Magneto Dropoff	
Left 85	
Right 90	
Radio checked out before.	

(a) All readings taken at full-rich position.

TABLE D.3 MATERIAL DAMAGE INSPECTION PLAN AND RESULTS

Ship YAG 39 Plane No. 81724 Shot 2  
 Date and Time of Inspection 9 Mar. (Before) and 29 Mar. (After)

Material or Area Inspected	Findings
Engine Turnup Data (Before) <sup>(a)</sup> 1. Similar to data taken (After) Shot 1  Radio checked out.	Engine Data (After) <sup>(a)</sup> 1. Similar to data taken (Before) except that: A. Magneto Dropoff was: 1. Right 450 and cut out completely. 2. Left 60 B. Cylinder heat temperature gauge was out.  2. Plugs on front bank of cylinders were changed and the Magneto dropoff was: A. Right 150-200 and still cut-out. B. Left 60  Radio checked out.  Excessive water noted where lead goes into plug.  Rust noted on main engine mount in accessory section.  Rust was evident on unpainted ferrous metal as noted before.  Corrosion was noted on wheel rims (inside)

(a) All readings taken at full-rich position.

TABLE D.4 MATERIAL DAMAGE INSPECTION PLAN AND RESULTS

Ship YAG 40 Plane No. 81624 Shot 2  
 Date and Time of Inspection 9 Mar. (Before) and 29 Mar. (After)

Material or Area Inspected	Findings
Engine Turnup Data (Before) <sup>(a)</sup> 1. Similar to data taken (After) Shot 1  Radio checked out.	Engine Turnup Data (After) <sup>(a)</sup> 1. Similar to data taken (Before) except that Magneto dropoff was: A. Right 90 B. Left 60 and the oil temp. gauge was out.  Radio checked out.  Rust was evident on ferrous metals as noted before.

(a) All readings taken at full-rich position.

TABLE D.5 MATERIAL DAMAGE INSPECTION PLAN AND RESULTS

Ship YAG 39 Plane No. 81777 Shot 4  
 Date and Time of Inspection 8 Apr. (Before) and 30 Apr. (After)

Material or Area Inspected	Findings
Engine Turnup Data (Before) <sup>(a)</sup> 1. RPM 1800 2. Cylinder Temperature 190°C 3. Manifold Pressure 27 in. 4. Oil Temperature 80°C 5. Fuel Pressure 16 lb 6. Oil Pressure 75 lb 7. Voltage 28 v 8. Hydraulic Pressure 1100 lb 9. Magneto Dropoff: A. Left 30 B. Right 40  Radio checked out.	Engine Turnup Data (After) <sup>(a)</sup> 1. Similar to data taken (Before) except that: A. Cylinder head temp. gauge needle oscillates at 140-150°C. B. Magneto Dropoff 1. Left 65 2. Right 85  Radio checked out.  Wing locking pin housings were in same condition as before the test. They were packed with grease before the test.

(a) All readings taken at full-rich position.

TABLE D.6 MATERIAL DAMAGE INSPECTION PLAN AND RESULTS

Ship YAG 39 Plane No. 81777 Shot 5  
 Date and Time of Inspection 30 April (Before) and 7 May (After)

Material or Area Inspected	Findings
Engine Turnup Data (Before) <sup>(a)</sup> 1. RPM 1800 2. Cylinder Temperature 190°C 3. Manifold Pressure 26 in. 4. Oil Pressure 75°C 5. Fuel Pressure 16 lb 6. Oil Pressure 80 lb 7. Voltage 27 v 8. Hydraulic Pressure 1100 lb 9. Magneto Dropoff A. Left 40 B. Right 50  Radio checked out.	Engine Turnup Data (After) <sup>(a)</sup> 1. RPM 1800 2. Cylinder Temperature 190°C 3. Manifold Pressure 25 in. 4. Oil Temperature 75°C 5. Fuel Pressure 16 lb 6. Oil Pressure 80 lb 7. Voltage Gauge Out 8. Hydraulic Pressure 1100 lb 9. Magneto Dropoff A. Left 75-85 B. Right 100 and cuts out.  Radio checked out.  Rust was evident on unpainted ferrous metals.  Wing locking pin housings were in same condition as before the test. They were packed with grease before the test.

(a) All readings taken at full-rich position.

TABLE D.7 MATERIAL DAMAGE INSPECTION PLAN AND RESULTS

Ship <u>YAG 40</u> Plane No. <u>82022</u> Shot <u>4</u>	
Date and Time of Inspection <u>8 Apr. (Before)</u> and <u>2 May (After)</u>	
Material or Area Inspected	Findings
Engine Turnup Data (Before)(a)	Engine Turnup Data (After)(a)
1. RPM 1800	1. Similar to data taken (Before) except that the left magneto was rough.
2. Cylinder Temp. gauge oscillates at 140-150°C	
3. Manifold Pressure 27 in.	
4. Oil Temperature 80°C	
5. Fuel Pressure 16 lb	
6. Oil Pressure 75 lb	
7. Voltage 28 v	
8. Hydraulic Pressure 1100 lb	
9. Magneto Dropoff	
A. Left 65	
B. Right 85	
Radio checked out.	

(a) All readings taken at full-rich position.

TABLE D.8 MATERIAL DAMAGE INSPECTION PLAN AND RESULTS

Ship <u>YAG 40</u> Plane No. <u>82022</u> Shot <u>5</u>	
Date and Time of Inspection <u>2 May (Before)</u> and <u>14 May (After)</u>	
Material or Area Inspected	Findings
Engine Turnup Data (Before)(a)	Engine Turnup Data (After)(a)
1. RPM 1800	1. RPM 2000
2. Cylinder Temperature 190°C	2. Cylinder Temperature 150°C
3. Manifold Pressure 25 in.	3. Manifold Pressure 27 in.
4. Oil Temperature 75°C	4. Oil Temperature 65°C
5. Fuel Pressure 16 lb	5. Fuel Pressure 16 lb
6. Oil Pressure 80 lb	6. Oil Pressure 78 lb
7. Voltage Gauge out	7. Voltage Gauge out
8. Hydraulic Pressure 1100 lb	8. Hydraulic Pressure 1100 lb
9. Magneto Dropoff	9. Magneto Dropoff
A. Left 75-85	A. Left Cut out
B. Right 100 and cuts out	B. Right Cut out
Radio checked out.	Radio checked out.
Rust was evident on unpainted ferrous metals.	Rust was evident on unpainted ferrous metals.
Wing locking pin housings were in the same condition as before Shot 4. They were packed with grease before the test.	Corrosion was evident on the magnesium wheels. No damage was evident on the wing locking pin housings.

(a) All readings taken at full-rich position.

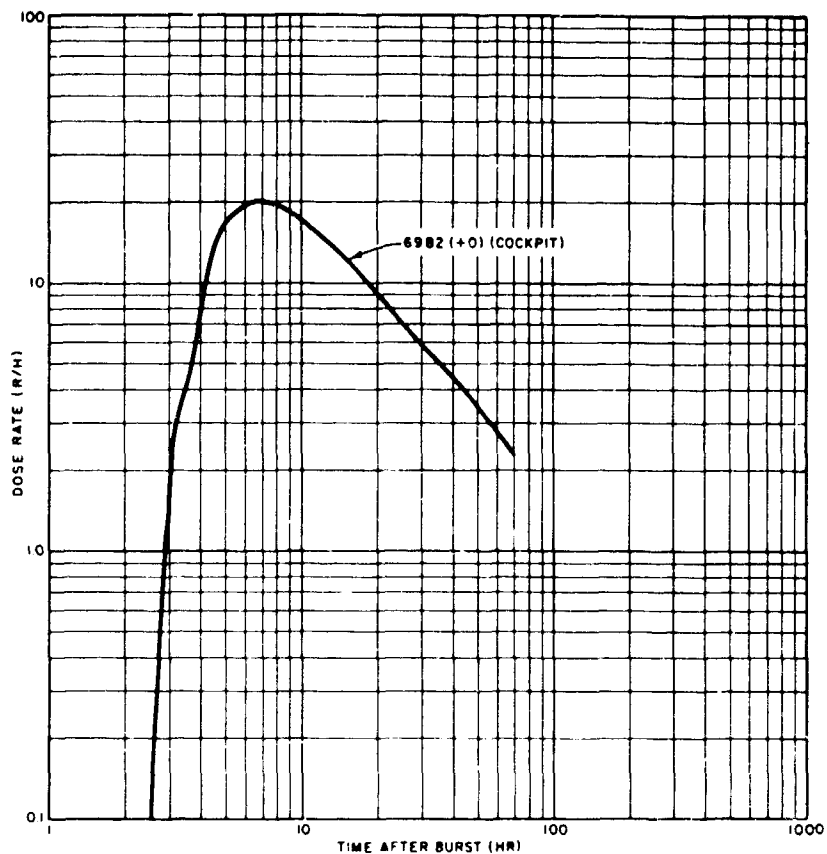

Figure D.1 Gamma dose rate at fixed gamma stations aboard YAG 40 after Shot 2.

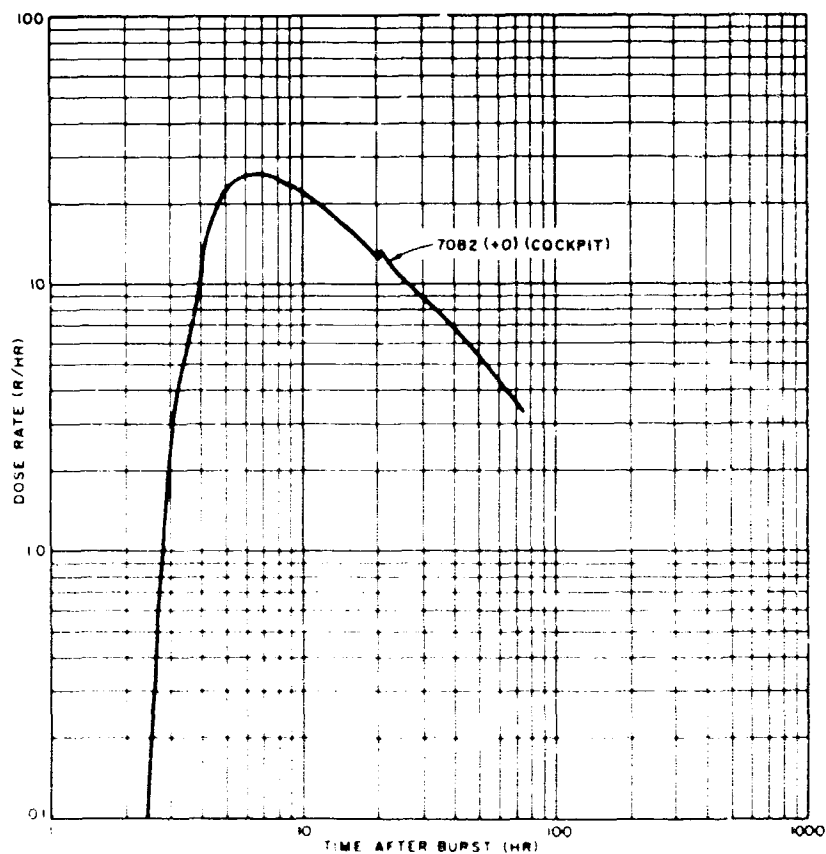

Figure D.2 Gamma dose rate at fixed gamma stations aboard YAG 40 after Shot 2.

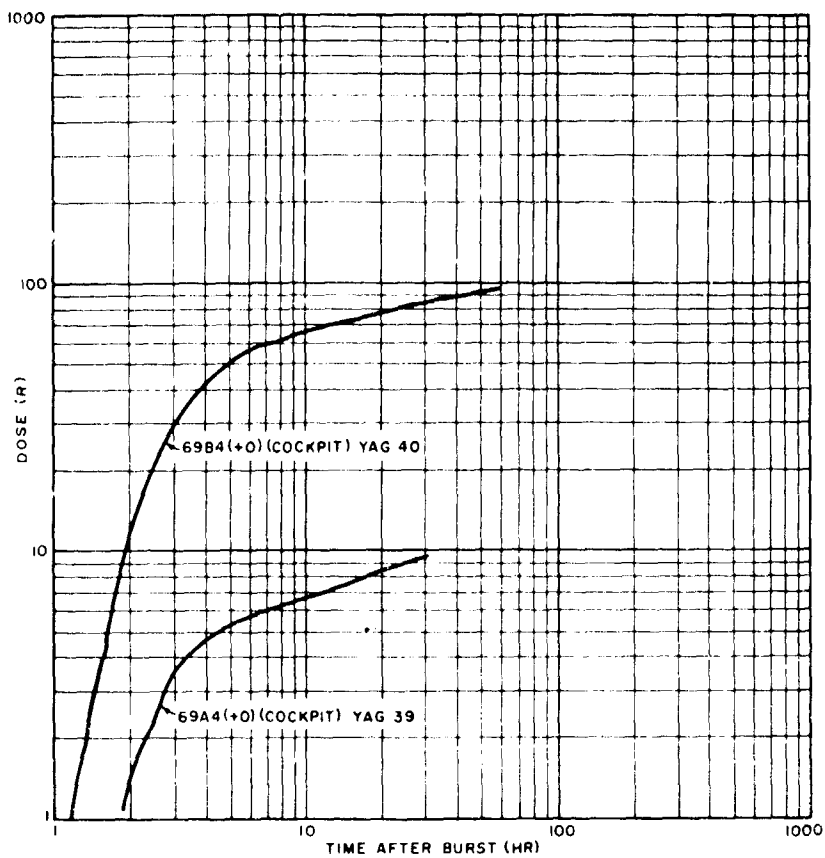

Figure D.3 Gamma doses at fixed gamma stations aboard the ships after shot 4.

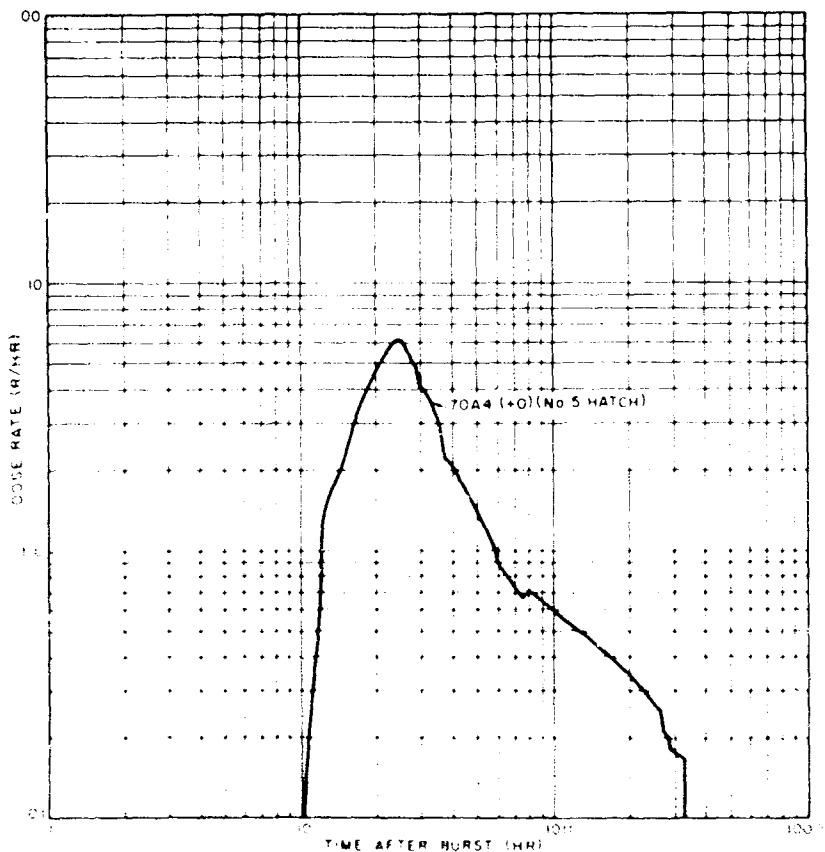

Figure D.4 Gamma dose rates at fixed gamma stations aboard YAG 39 after Shot 4.

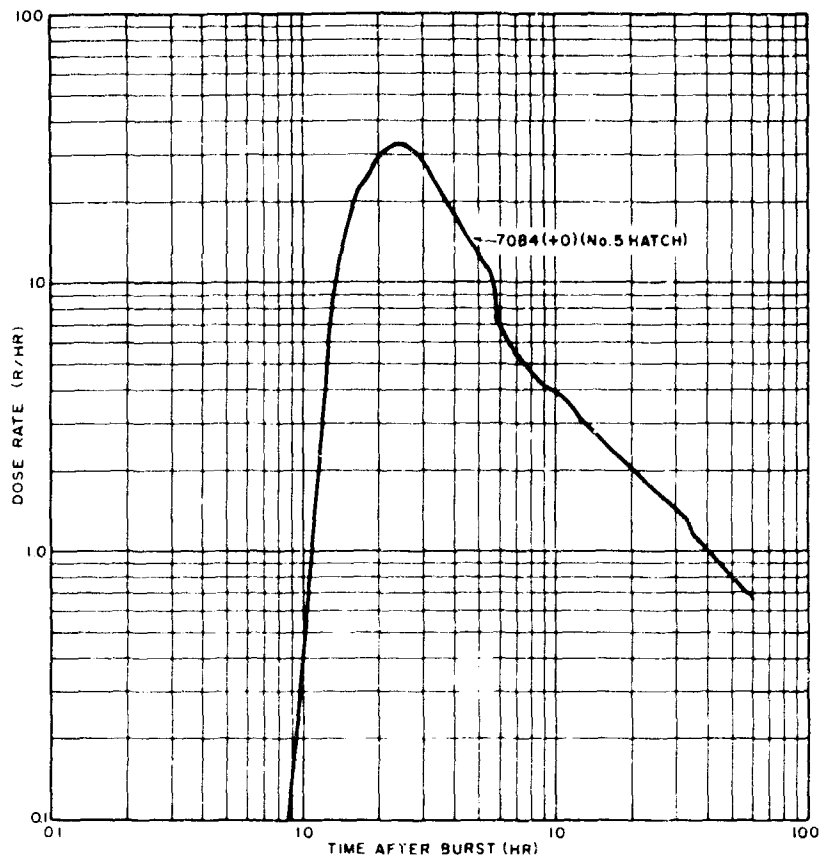

Figure D.5 Gamma dose rates at fixed gamma stations aboard YAG 40 after Shot 4.

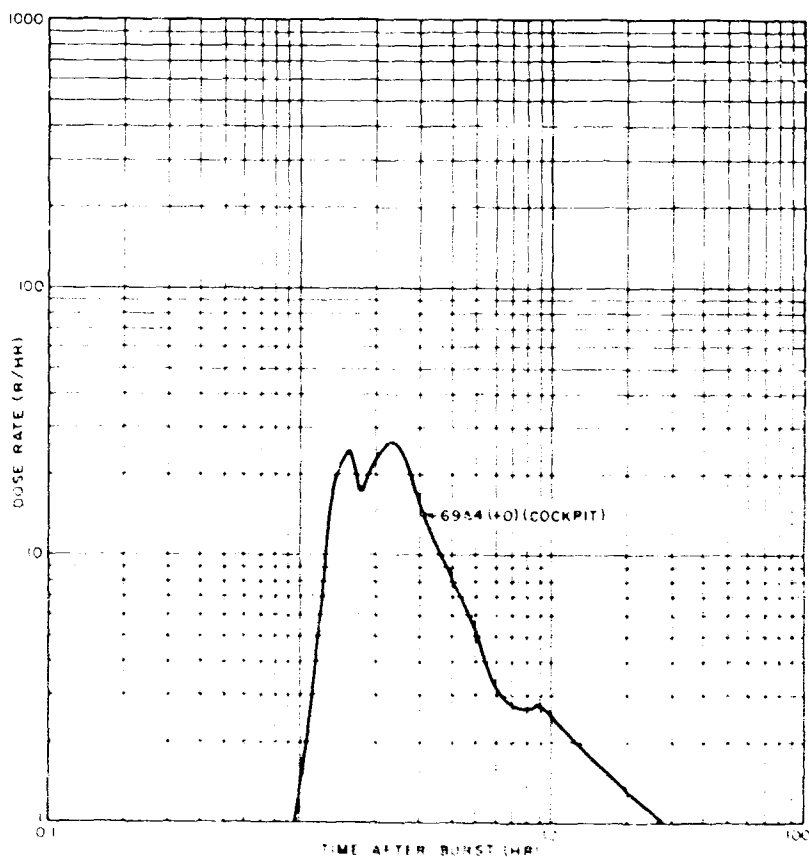

Figure D.6 Gamma dose rates at fixed gamma stations aboard YAG 39 after Shot 4.

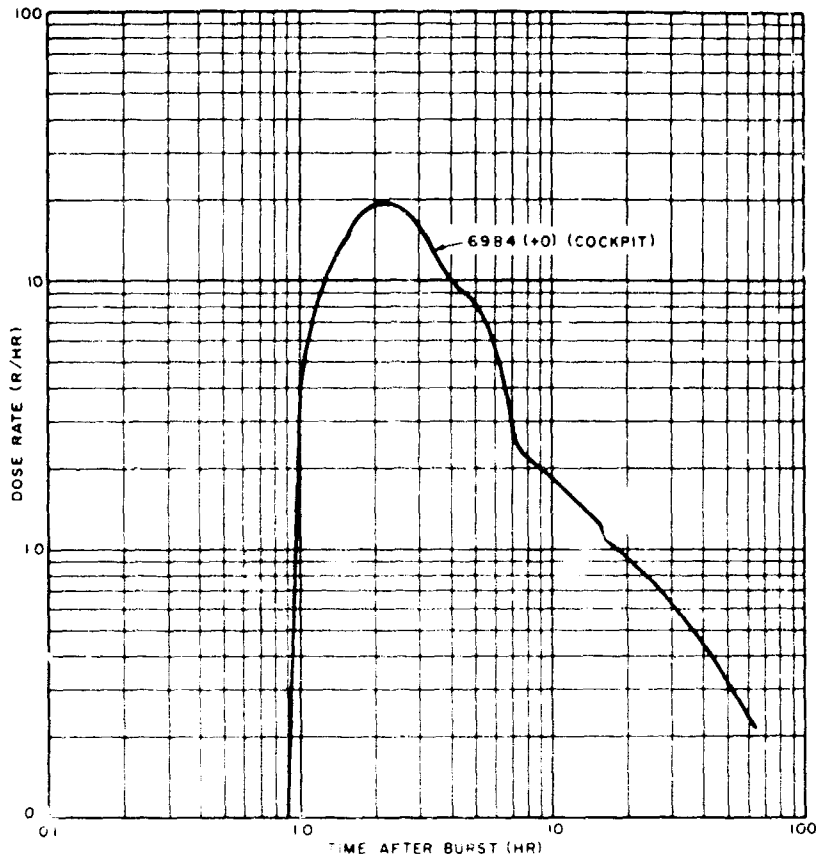

Figure D.7 Gamma dose rates at fixed gamma stations aboard YAG 40 after Shot 4.

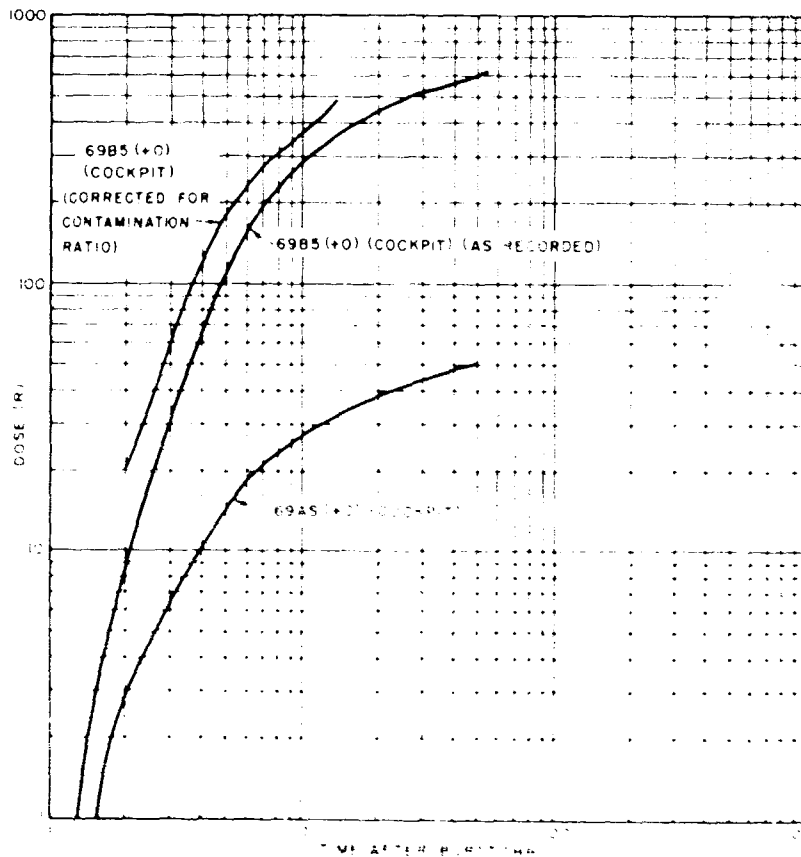

Figure D.8 Gamma doses at fixed stations aboard ship after Shot 5.



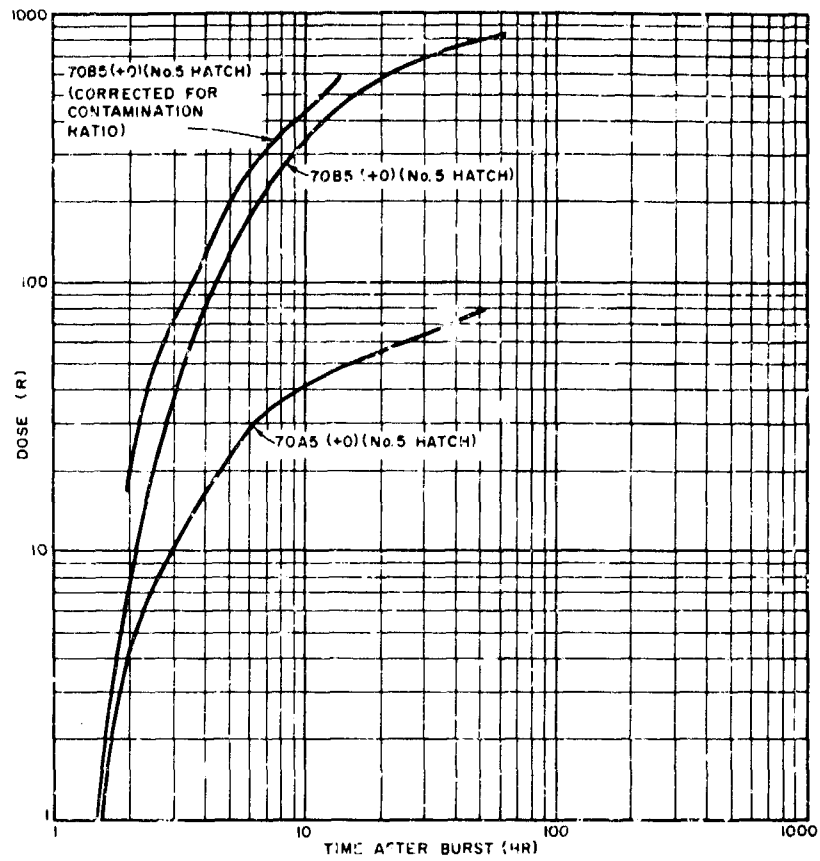

Figure D.9 Gamma doses at fixed gamma stations aboard ship after Shot 5.

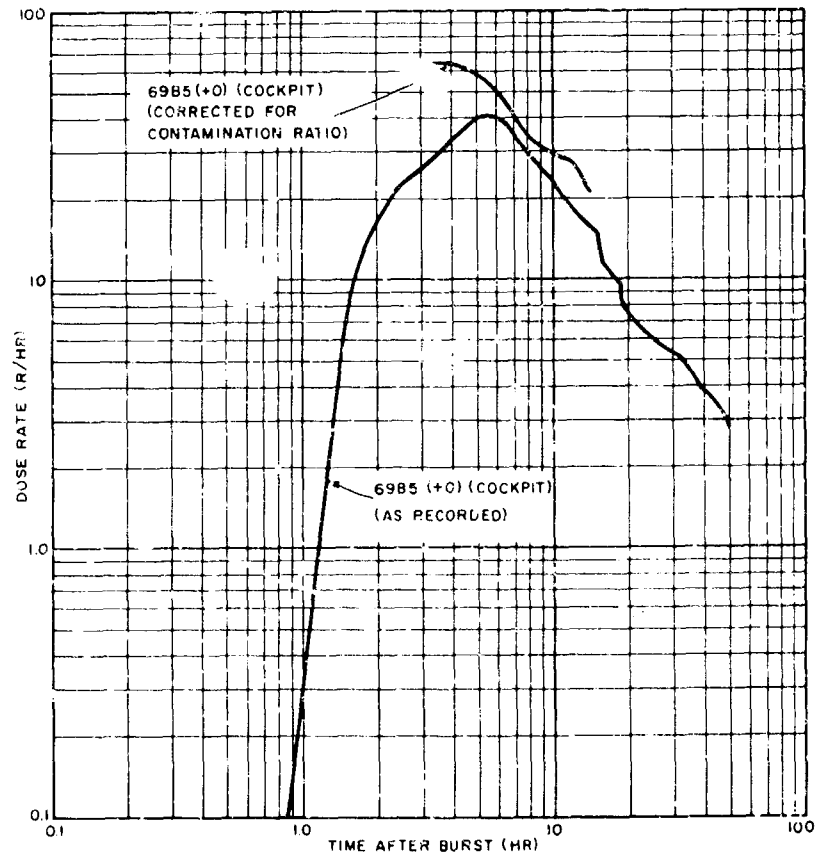

Figure D.10 Gamma dose rates at fixed gamma stations aboard YAG 40 after Shot 5.

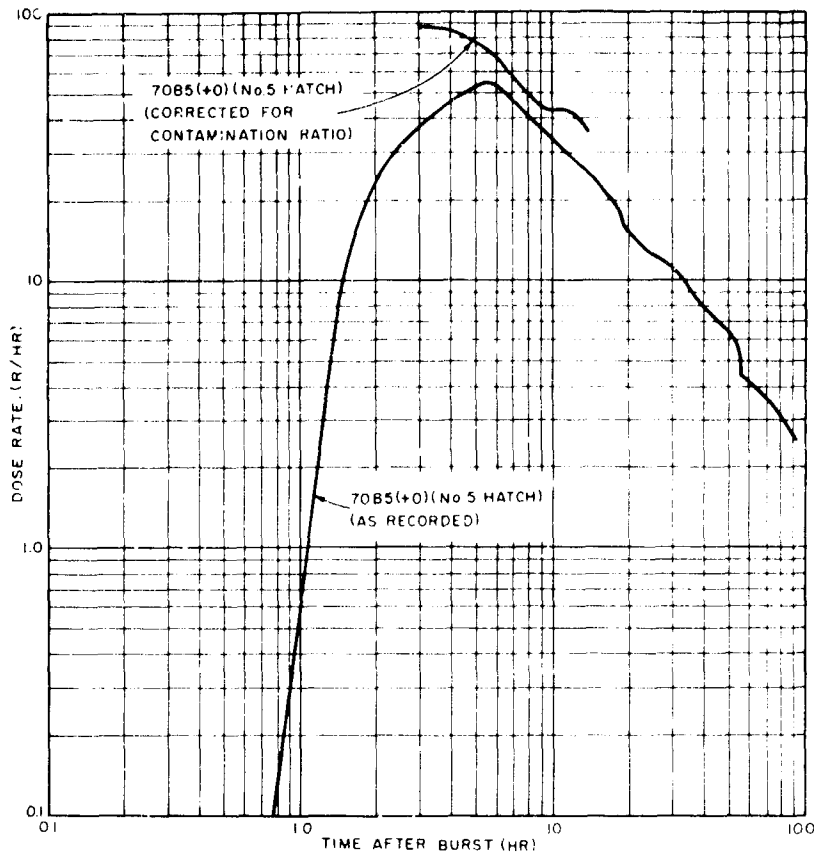

Figure D.11 Gamma dose rates at fixed gamma stations aboard YAG 40 after Shot 5.

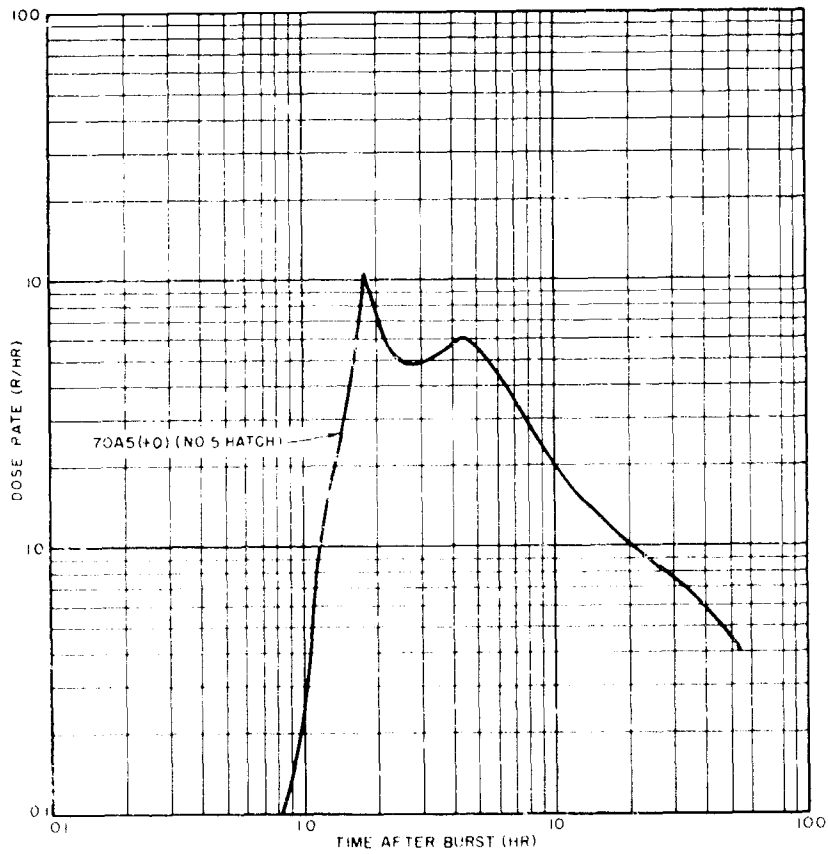

Figure D.12 Gamma dose rates at fixed gamma stations aboard YAG 39 after Shot 5.

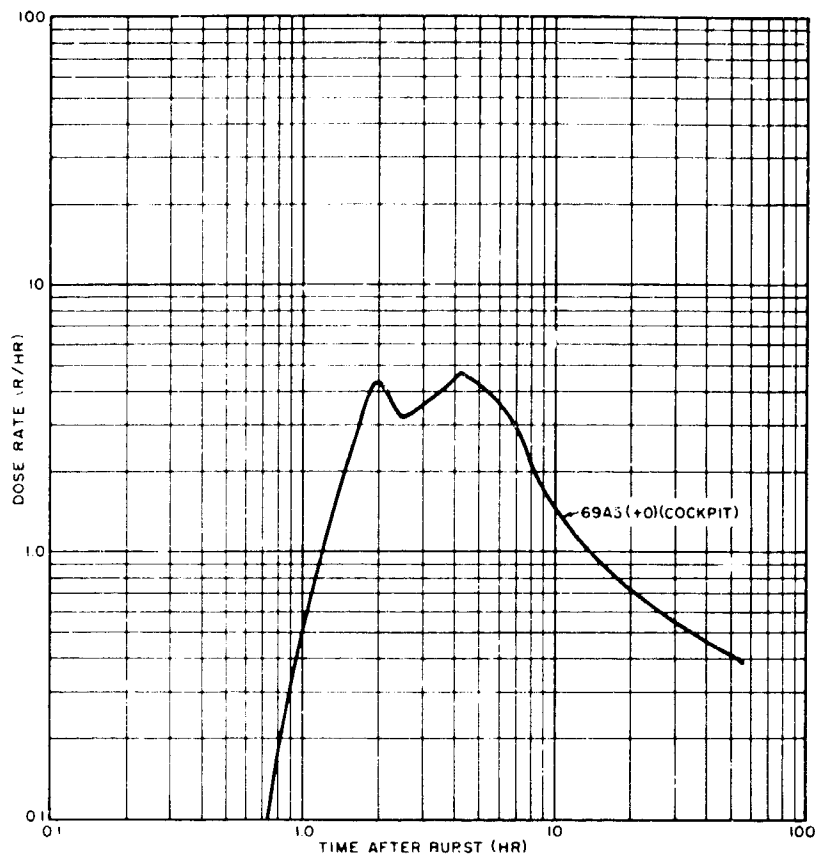

Figure D.13 Gamma dose rates at fixed gamma stations aboard YAG 39 after Shot 5.

D.2.3 Decontamination Effectiveness. This portion of the appendix includes not only decontamination operations, decontamination effectiveness, and time and manpower data but also the estimated materials requirements for the various decontamination processes used in this test.

Figures D.14 through D.17 give the flow charts and basic equipment and materials requirement for the decontamination processes used. Figure D.15 shows the portable pump used with the decontamination by firehosing at 100 psig. Table D.9 gives the decontamination sequences and time after shot for all the decontamination operations. Figures D.18 through D.29 are graphic representations of the decontamination effectiveness of the aircraft operations. Table D.10 is a comparison of decontamination effectiveness results from the aircraft and test plates. Table D.11 is a comparison of the decontamination effectiveness of the average gamma survey meter readings versus a high initial reading and a low initial reading. Table D.12 is the detailed time and manpower studies for the decontamination operations.

D.2.3.1 Estimated Material Requirements for the Different Decontamination Processes.

1. Firehosing, salt water
  - a. Single nozzle
    - 100 gpm or 600 gal/hr

- b. Two nozzles  
200 gpm or 12,000 gal/hr
- 2A. Hot liquid jet with salt water, base rate
- a. Salt water to unit, 850 gal/hr
  - b. Fresh water (steam generation, 100 gal/hr)
  - c. Salt water (detergent solution) 50 gal/hr
  - d. Detergent (C-120) 100 lb/hr while washing
- 2B. Hot liquid jet with salt water, estimated amount used per hour for hot liquid jet only, no scrubbing (50 percent detergent, 50 percent rinse)
- a. Salt water to unit, 850 gal/hr
  - b. Fresh water (steam generation) 100 gal/hr
  - c. Salt water (detergent solution) 25 gal/hr
  - d. Detergent (C-120), 50 lb/hr
  - e. Totals, Salt water, 875 gal/hr  
Fresh water (steam), 100 gal/hr  
Detergent (C-120), 50 lb/hr
- 3A. Hot-liquid jet with fresh water, base rate
- a. Fresh water to unit, 850 gal/hr
  - b. Fresh water (steam generation) 100 gal/hr
  - c. Fresh water (detergent solution) 50 gal/hr
  - d. Detergent (C-120) 100 lb/hr while washing
  - e. Total, fresh water, 975 gal/hr  
detergent (C-120), 50 lb/hr
- 4A. Single scrub, with hot-liquid-jet fresh-water rinse, base rate.
- a. Fresh water to unit, 850 gal/hr
  - b. Fresh water (steam generation), 100 gal/hr
  - c. Fresh water (detergent solution), 100 gal/hr
  - d. Detergent (C-120), 200 lb/hr

4B. Single scrub, with hot liquid jet fresh water rinse, estimated amounts used per hour. Ratio 70 percent scrubbing, 30 percent rinse.

- a. Fresh water to unit, 255 gal/hr
- b. Fresh water (steam generation) 30 gal/hr
- c. Fresh water (detergent solution), 70 gal/hr
- d. Detergent (C-120), 140 lb/hr
- e. Totals, fresh water, 355 gal/hr  
detergent, 40 lb/hr

5A. Single scrub with hot-liquid-jet salt-water rinse, base rate

- a. Salt water to unit, 850 gal/hr
- b. Fresh water (steam generation), 100 gal/hr
- c. Salt water (detergent solution), 100 gal/hr
- d. Detergent (C-120), 200 lb/hr

5B. Single scrub, with hot liquid jet salt water rinse, estimated amounts used per hour. Ratio, 70 percent scrubbing, 30 percent rinsing.

- a. Fresh water (steam generation), 30 gal/hr
- b. Salt water (hot liquid jet), 255 gal/hr
- c. Salt water (detergent solution), 70 gal/hr
- d. Detergent (C-120), 140 lb/hr
- e. Total, Fresh water, 30 gal/hr  
Salt water, 325 gal/hr  
Detergent, 140 lb/hr

6A. Single scrub, with Gunk, followed by hot-liquid-jet fresh-water-with-detergent rinse, followed by clear hot-liquid-jet fresh-water rinse, base rates.

- a. Gunk, Spraying, 30 gal/hr  
Scrubbing, 10 gal/hr
- b. Kerosene, Spraying, 240 gal/hr  
Scrubbing, 80 gal/hr

- c. Fresh water (to unit), 850 gal/hr
  - d. Fresh water (steam generation), 100 gal/hr
  - e. Fresh water (detergent solution), 50 gal/hr
  - f. Detergent (C-120), 100 lb/hr while washing
- 6B. Single scrub, with Gunk, followed by hot-liquid-jet fresh-water-with-detergent rinse, followed by clear hot-liquid-jet fresh-water rinse. Estimated 10 percent spraying Gunk, 60 percent scrubbing, 15 percent detergent rinse, 15 percent clear fresh rinse.
- a. Gunk, Spraying, 3 gal/hr  
Scrubbing, 1 gal/hr

TABLE D.9 DECONTAMINATION SEQUENCES AT VARIOUS TIMES AFTER SHOTS

Decon. Number	Shot 2 YAG 40	Shot 4 YAG 39	Shot 4 YAG 40	Shot 5 YAG 39	Shot 5 YAG 40
1	Fire Hose	Scrub with detergent	Hot-liquid jet	Hot-liquid jet	Hot-liquid jet
Time after Shot	124-126 1/2	54-57 hrs	123-124 hrs	77-79 hrs	76-79 hrs
2	Fire hose	Scrub with detergent	Scrub with detergent	Scrub with detergent	Scrub with detergent
Time after Shot	126 1/2-129	77-81	124-128	103-105	79-82
3	Hot-liquid jet		Scrub with detergent	Scrub with detergent	Scrub with detergent
Time after Shot	147-154		128-130	125-130	99-105
4	Scrub with detergent				Scrub with detergent
Time after Shot	173-176				122-129
5	Scrub with detergent				Scrub with Gunk
Time after Shot	194-197				148-151
6	Scrub with detergent				Scrub with Gunk
Time after Shot	197-201				170-173
7	Scrub with Gunk				
Time after Shot	218-221				
8	Scrub with Gunk				
Time after Shot	221-224				

Time after shot indicates times when monitoring surveys were made before and after decontamination.

TABLE D.10 COMPARISON OF DECONTAMINATION EFFECTIVENESS RESULTS FROM AIRCRAFT AND TEST PLATES  
BASED ON GAMMA SURVEY

	Decon.Method	1st Decontamination		2nd Decontamination		3rd Decontamination	
		% of original contamination removed by this decon.	% of original contamination remaining after this decon.	% of previous contamination removed by this decon.	% of original contamination remaining after this decon.	% of previous contamination removed by this decon.	% of original contamination remaining after this decon.
	Decon.Method	Firehose at 100 lb/sq in		Firehose at 100 lb/sq in		Hot Liquid Jet	
Shot 2 YAG 40	Aircraft	36	64	28	49	27	45
	Test Plates	35	65	30	46	-	-
	Decon.Method	Hot Liquid Jet		Scrub with Detergent		Scrub with Detergent	
Shot 4 YAG 40	Aircraft	23	77	39	50	14	44
	Test Plates	29	71	50	35	-3	36
	Test Plates	26	74	-1	75	50	37
	Decon.Method	Firehose at 20 lb/sq in		Firehose at 20 lb/sq in		Scrub with Detergent	
	Test Plates	3	92	4	88	54	40
	Decon.Method	Hot Liquid Jet		Scrub with Detergent		Scrub with Detergent	
Shot 5 YAG 40	Aircraft	32	68	37	46	14	42
		2 Hot Liquid Jets					
	Test Plates	26	74	76	18	21	14
	Decon.Method	2 Firehosings at 100 lb/sq in		Scrub with Detergent		Scrub with Detergent	
	Test Plate	15	85	75	21	52	10

TABLE D.11 DECONTAMINATION EFFECTIVENESS - COMPARISON OF AVERAGE T1B READING FOR AIRCRAFT ABOARD  
YAG 40 AFTER SHOT 2 VERSUS LOCATION 40 (HIGH INITIAL) VERSUS LOCATION 20 (LOW INITIAL)

	Average T1B Readings			Readings at Location 40			Readings at Location 20		
	mr/hr	% of Remaining Contaminant Removed		mr/hr	% of Remaining Contaminant Removed		mr/hr	% of Remaining Contaminant Removed	
		By Decay	By Decon.		By Decay	By Decon.		By Decay	By Decon.
31 March - Before decontamination	2620			10,300			1500		
By Decay	2240	14		8,870	14		1290	14	
Reduction attributed to rain			8			30			22
1 April - Before 1st decontamination	2060			6,250			1000		
By decontamination	1330		36	2,800		55	850		15
After 1st Decon.		3			3			3	
By Decay									
1 April - Before 2nd decontamination	1290			2,720			825		
By decontamination	970		28	2,000		26	500		39
After 2nd decon.									
By decay			+7(a)		3				+40(a)
2 April - Before 3rd Decon.	1040			1,930			700		
By decontamination	770		27	1,300		33	450		36
After 3rd Decon.									
By Decay		10			10			10	
3 April - Before 4th Decon.	693			1,170			395		
By decontamination	315		55	215		82	225		44
After 4th Decon.									

(a) Readings were higher after decay period. Location 40 is on top or inboard side of left wing, See Fig. D-30. Location 20 is on right side of fuselage just behind the cockpit, See Fig. D-30.

TABLE 2-1-1. Fire and Rampdown Studies of Aircraft Decontamination

Shot and Aircraft	Decontamination Method	Percentage of Contaminant Removed	Actual Decontamination Time	Estimated Total Decontamination Time (hr)	Number Total Used	Decontamination Rate		Distribution of Manpower
						Based on	Actual	
		Average	Time	(hr)	Hours	Time	Time	
Percentage of Contaminant Removed								
		Fixed 7						
		Cockpit						
		Readings						
Average used for fire and rampdown comparison								
HOT LIQUID								
Shot 4								
YAG 40	1st	30	5 min-34 sec	0.1	4	21,500	20,000	1-supervisor, 1-nozzleman, 1-hoseman, 1-pump tender.
	2nd	34	20 min (est.)	0.4	6*	3,000	2,500	
		27%	15 min-11 sec	0.3	3/3	9,200(b)	8,300(b)	* for 2nd FH an additional 1-nozzleman, 1-hoseman
			20 min	0.4	4	6,000	6,000	
FIRE HOSE								
Shot 4								
YAG 40	3rd	27	20 min-31 sec	0.5	4	5,850	4,000	
Shot 5								
YAG 40	1st	23	23 min-0 sec	0.5	4	5,200	4,000	1-supervisor
Shot 5								1-equipment man
YAG 40	1st	22	32 min-40 sec	0.67	4	3,650	3,000	1-lanceman
		27%						1-hoseman
HOT LIQUID								
Shot 5								
YAG 39	1st	18%	22 min-0 sec	0.75	4	4,150	2,670	
Rampdown			26 min-18 sec	0.6	4	4,600	3,450	
SINGLE SCRUB WITH DETERGENT								
Shot 7								
YAG 40	2nd	39	51 min-30 sec	1.25	6	2,350	1,600	1-supervisor, 1-equipment operator, 1-lanceman, 3-scrubbers
	3rd	14	53 min-30 sec	1.5	9*	2,250	1,300	
		27%	52 min-30 sec	1.375	7.5	2,300	1,450	* An additional 3 scrubbers
DOUBLE SCRUB WITH DETERGENT								
Shot 5								
YAG 40	2nd	37	80 min-50 sec	2	8*	1,500	1,000	1-supervisor
	3rd	14	73 min-50 sec	2	7	1,600	1,000	1-equipment operator
	4th	20	115 min-36 sec	2 1/2	7	1,050	800	1-lanceman
		26%						4-scrubbers
Shot 5								* An additional 1-scrubber
YAG 39	2nd	17%	58 min-25 sec	1 1/2	7	2,050	1,300	
Rampdown			62 min-10 sec	2	7.25	1,550	1,000	

(a) FH stands for fire hoseing.  
 (b) Average is obtained by dividing by 3 because 1 nozzle was used on the first wash and 2 nozzles were used on the second wash.  
 (c) RLJ stands for hot-liquid jet.



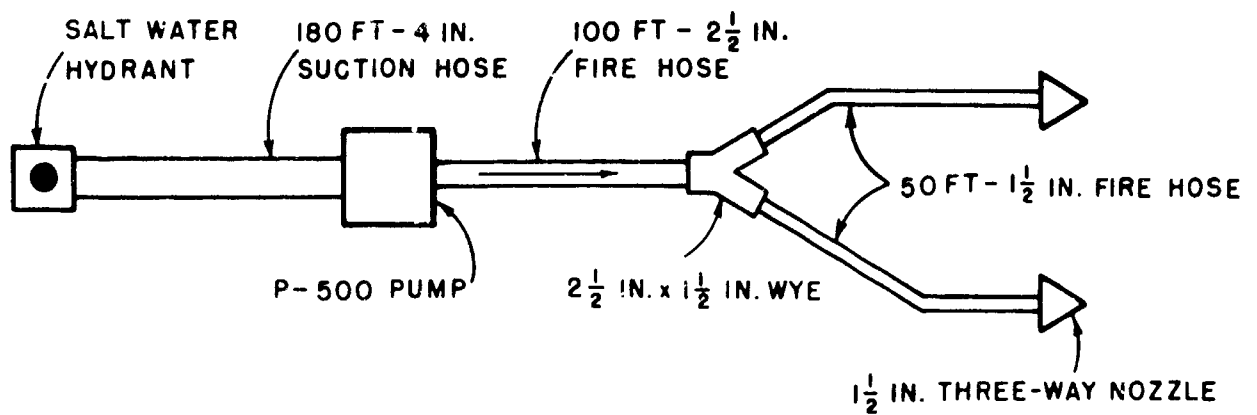

INLET HYDRANT PRESSURE

20 LB/SQ IN. (EST)

OUTLET - P-500 PUMP

100 LB/SQ IN.  
100 GPM (EST)

EQUIPMENT USED

- 180 FT - 4 IN. SUCTION HOSE
- 1 P-500 PUMP
- 100 FT - 2 1/2 IN. FIRE HOSE
- 100 FT - 1 1/2 IN. FIRE HOSE
- 2 1 1/2 IN THREE-WAY NOZZLE

Figure D.14 Equipment hookup for firehosing with salt water.

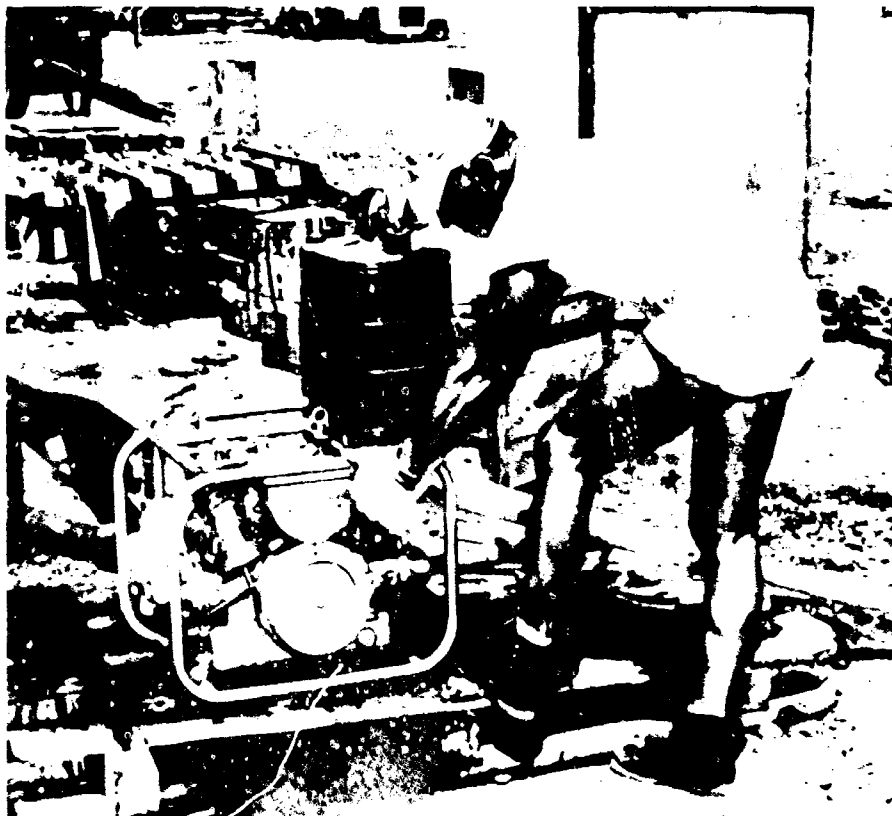
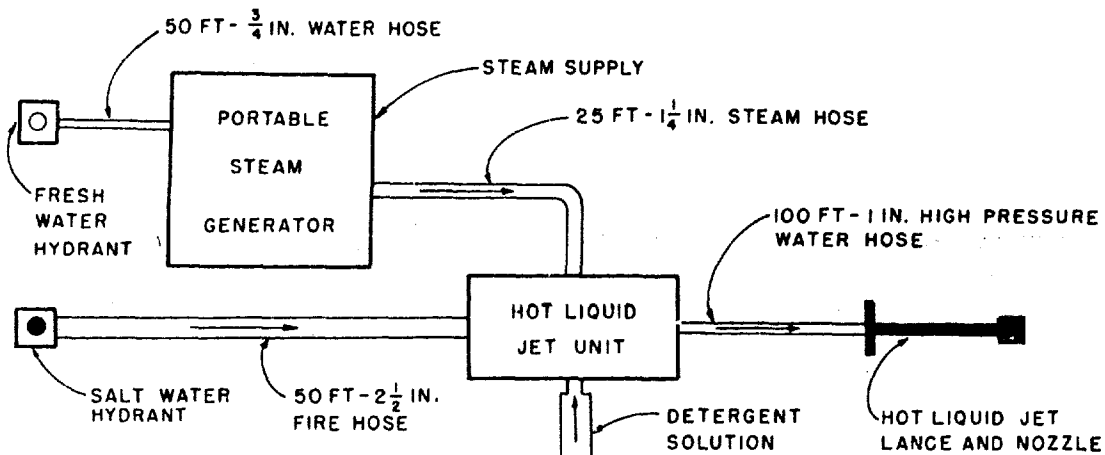

Figure D.15 Equipment used to boost the water pressure to that needed for firehosing.



INLET SALT WATER HYDRANT  
20 LB/SQ IN. 850 GPH (EST)

INLET FRESH WATER HYDRANT  
20 LB/SQ IN. 100 GPH (EST)

INLET DETERGENT SOLUTION  
50 GPH (EST)

OUTLET HOT LIQUID JET NOZZLE  
1000 GPH (EST)

170° F TEMPERATURE

180 LB/SQ IN. PRESSURE

EQUIPMENT USED

50 FT -  $\frac{3}{4}$  IN. WATER HOSE

STEAM GENERATOR

25 FT -  $\frac{1}{4}$  IN. STEAM HOSE

50 FT -  $2\frac{1}{2}$  IN. FIRE HOSE

1 HOT LIQUID JET UNIT  
(1000 GAL/HR)

100 FT - 1 IN. HIGH PRESSURE  
WATER HOSE

1 HOT LIQUID JET LANCE  
AND NOZZLE

Figure D.16 Equipment hookup for hot-liquid-jet wash with salt water.

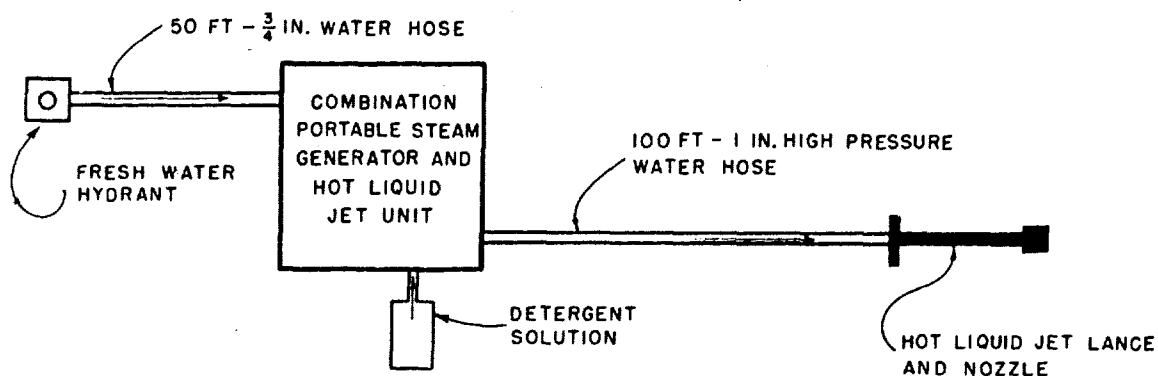

INLET FRESH WATER HYDRANT  
75 LB/SQ IN. (EST)  
950 GPH (EST)

INLET DETERGENT  
50 GPH (EST)

OUTLET HOT LIQUID JET NOZZLE  
1000 GPH (EST)

170° F TEMPERATURE

180 LB/SQ IN. PRESSURE

EQUIPMENT USED

50 FT -  $\frac{3}{4}$  IN. WATER HOSE

COMBINATION PORTABLE STEAM  
GENERATOR AND HOT LIQUID  
JET UNIT

100 FT - 1 IN. HIGH PRESSURE  
WATER HOSE

1 HOT LIQUID JET LANCE  
AND NOZZLE

Figure D.17 Equipment hookup for hot-liquid-jet wash with fresh water.

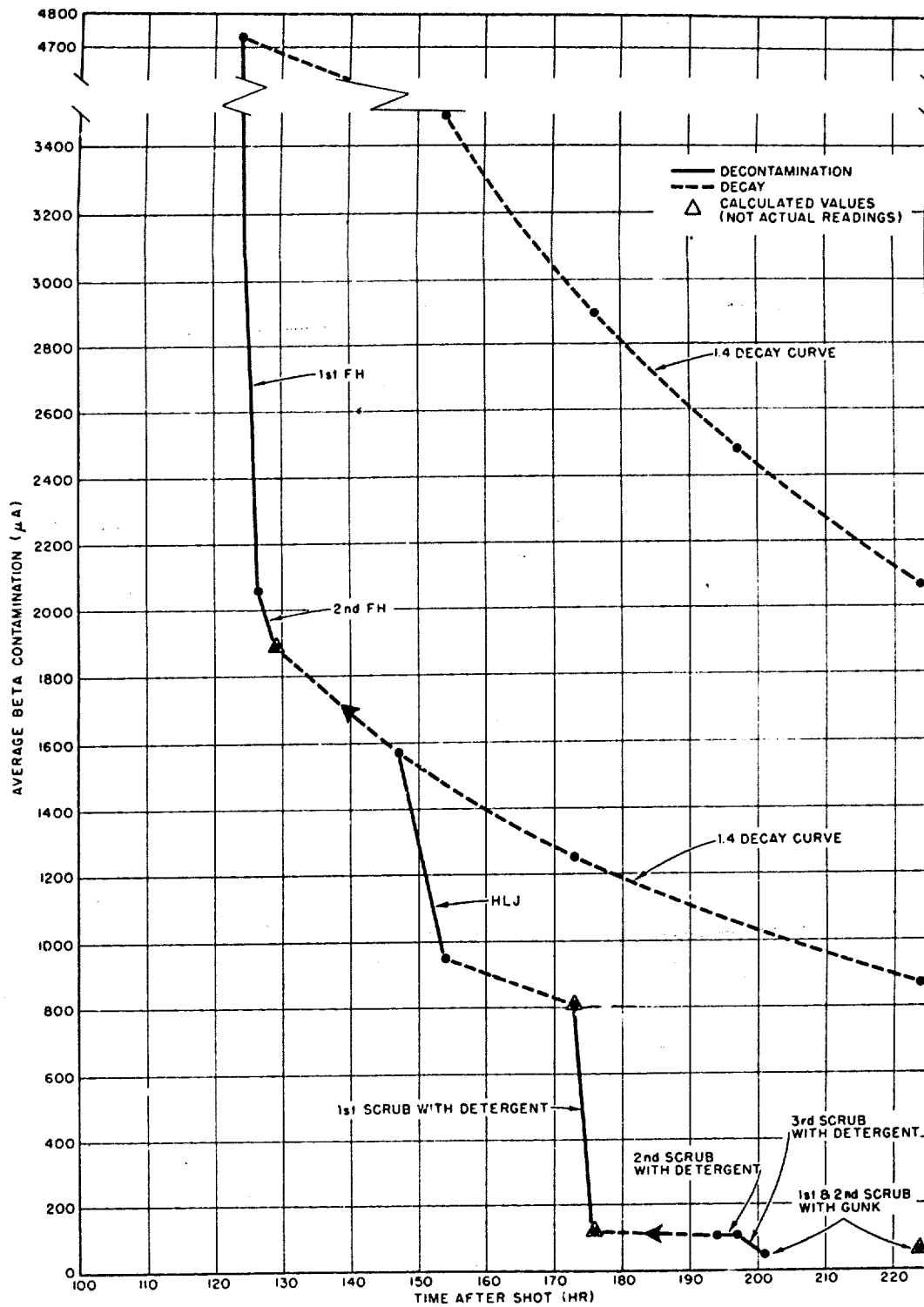

Figure D.18 Decontamination effectiveness for all operations on the aircraft aboard the YAG 40 after Shot 2.

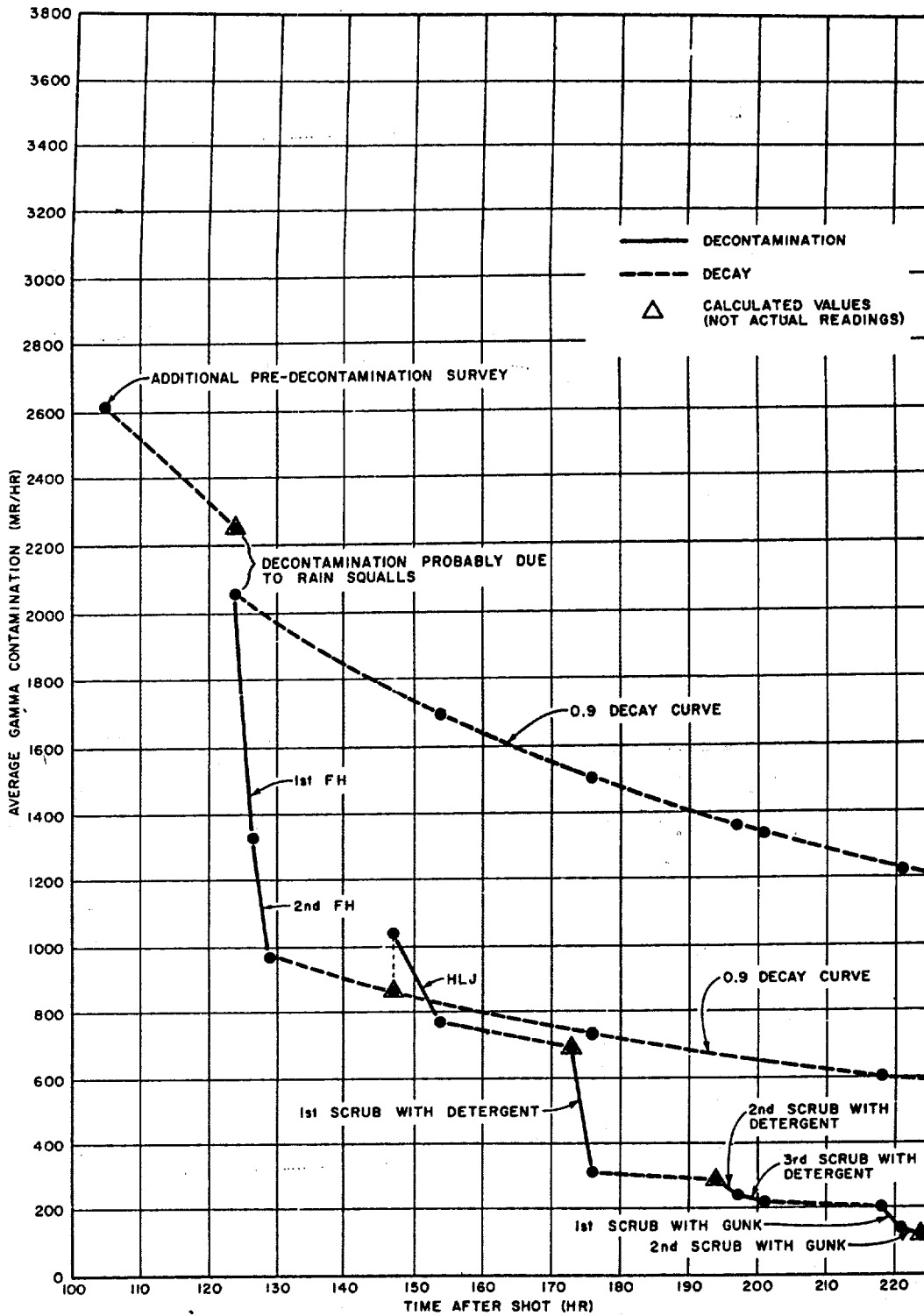

Figure D.19 Decontamination effectiveness for all operations on the aircraft aboard the YAG 40 after Shot 2.

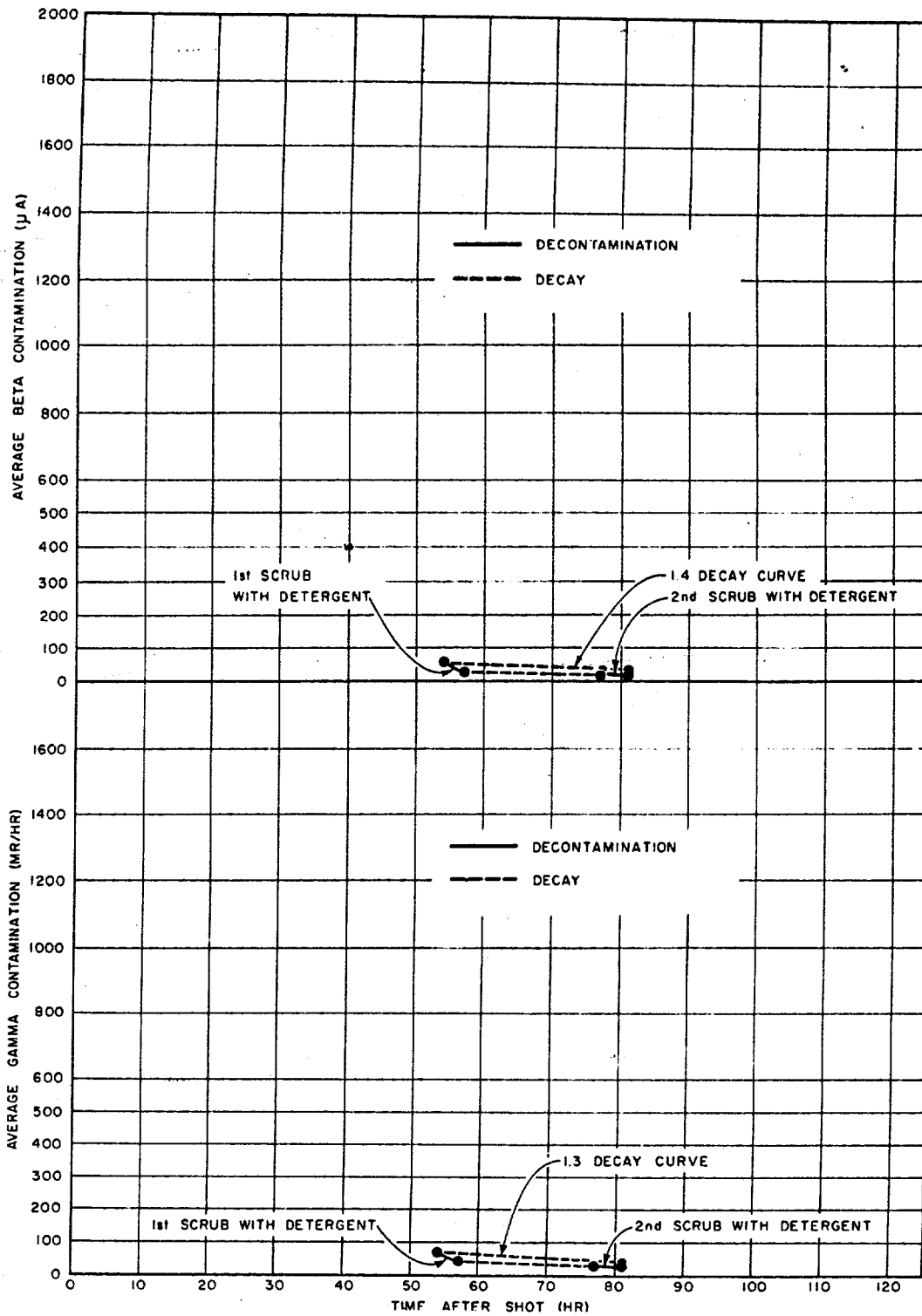

Figure D.20 Decontamination effectiveness for all operations on the aircraft aboard the YAG 39 after Shot 4.

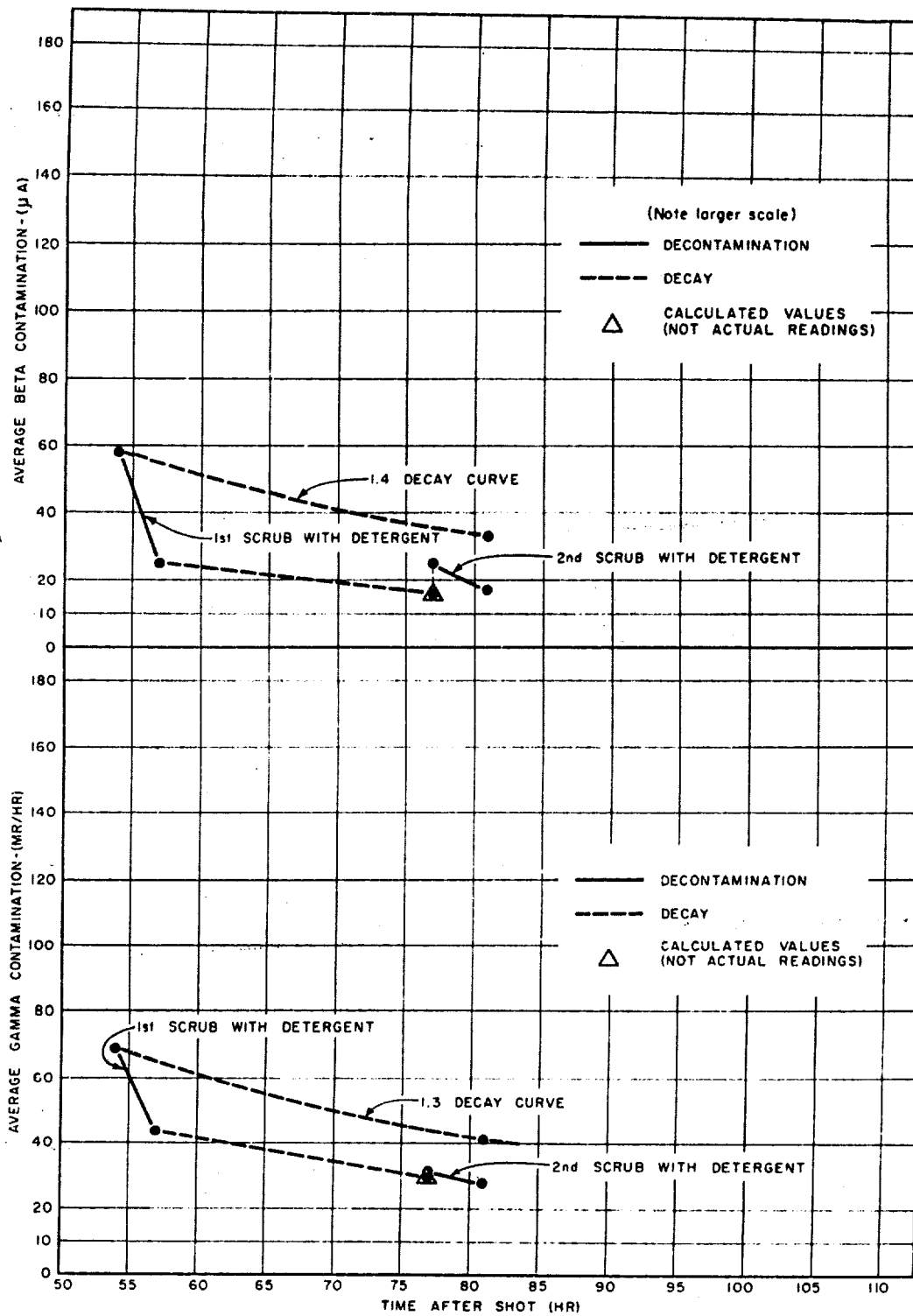

Figure D.21 Decontamination effectiveness for all operations on the aircraft aboard the YAG 39 after Shot 4.

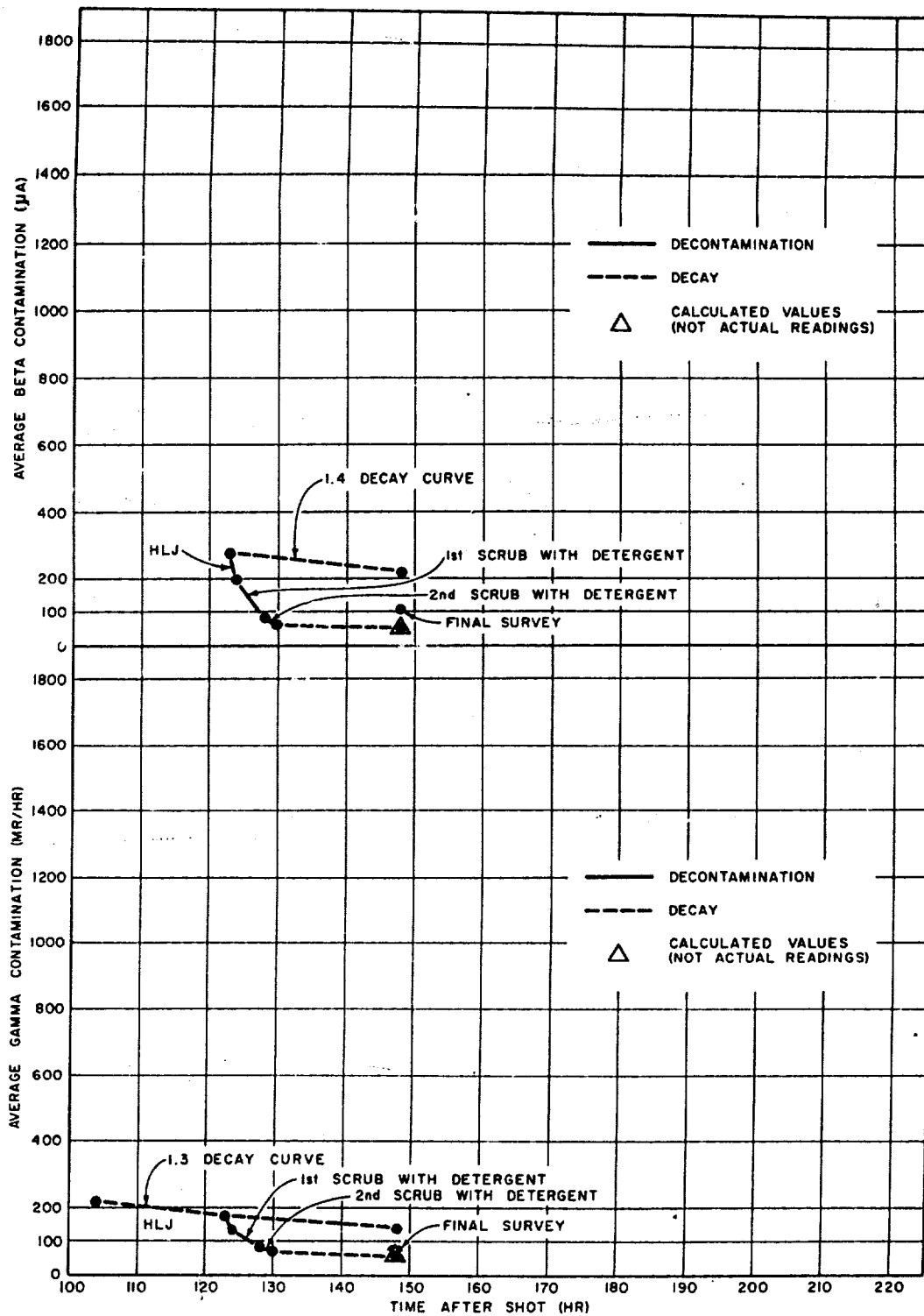

Figure D.22 Decontamination effectiveness for all operations on the aircraft aboard the YAG 40 after Shot 4.

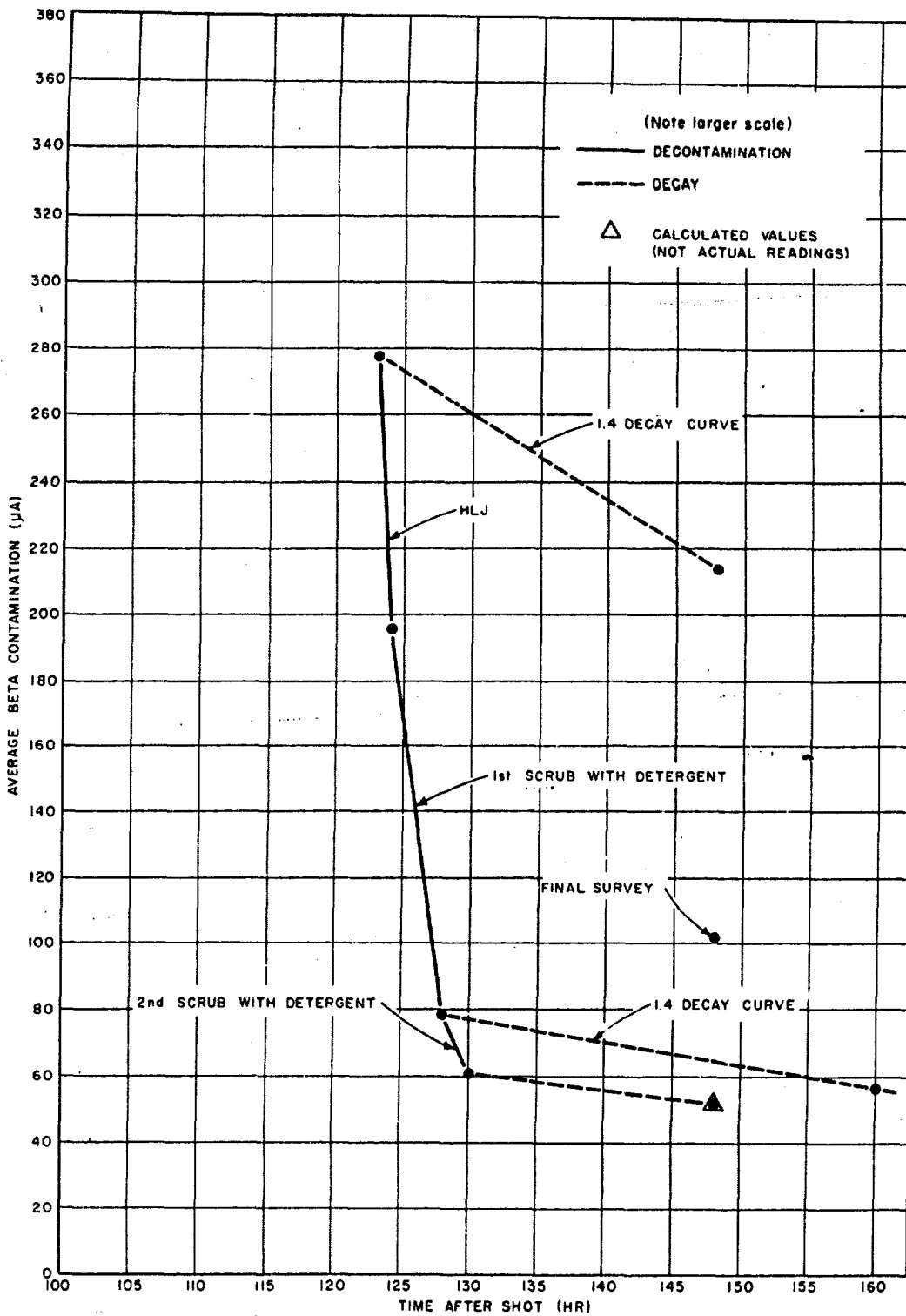

Figure D.23 Decontamination effectiveness for all operations on the aircraft aboard the YAG 40 after Shot 4.



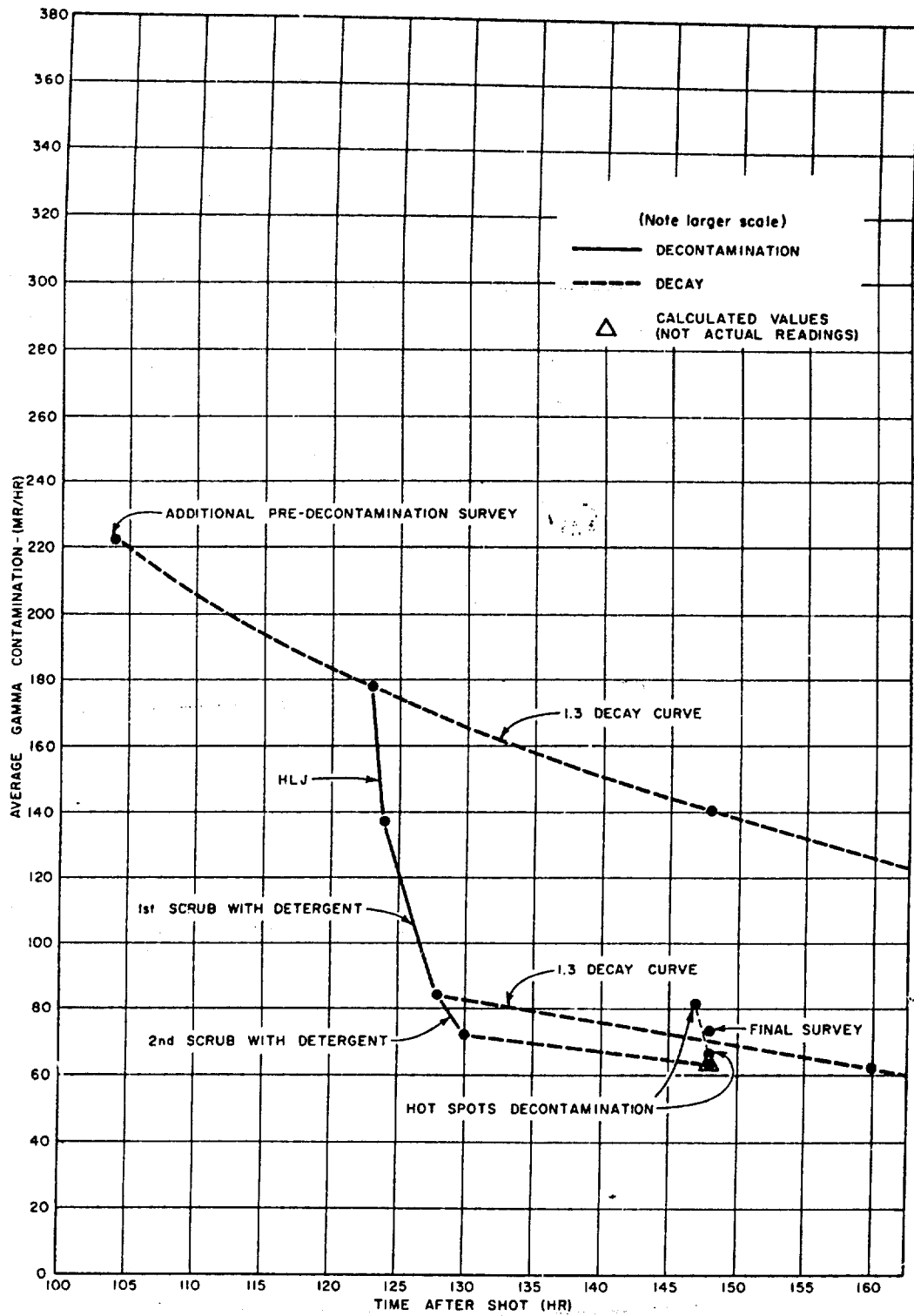

Figure D.24 Decontamination effectiveness for all operations on the aircraft aboard the YAG 40 after Shot 4.

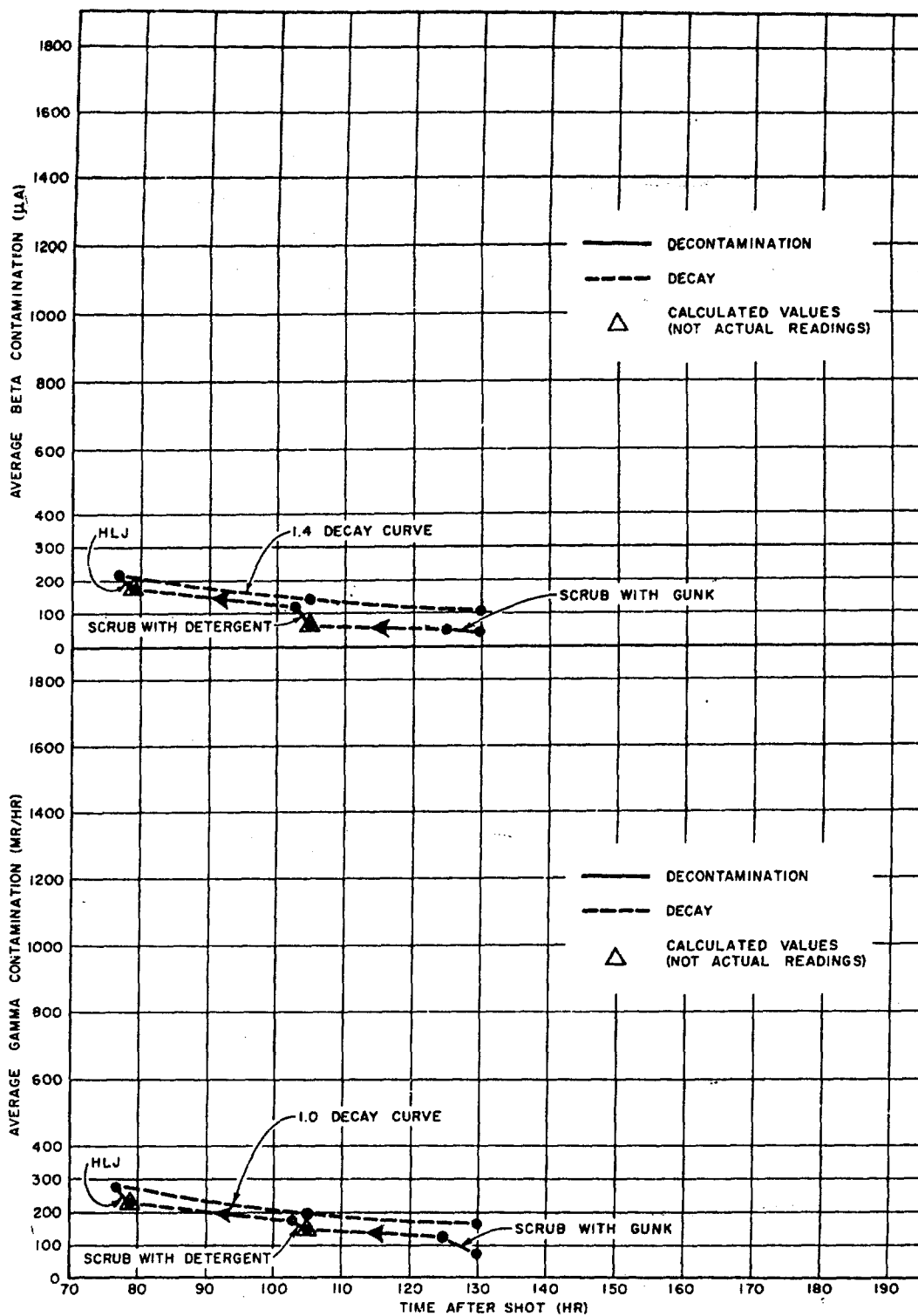

Figure D.25 Decontamination effectiveness for all operations on the aircraft aboard the YAG 39 after Shot 5.

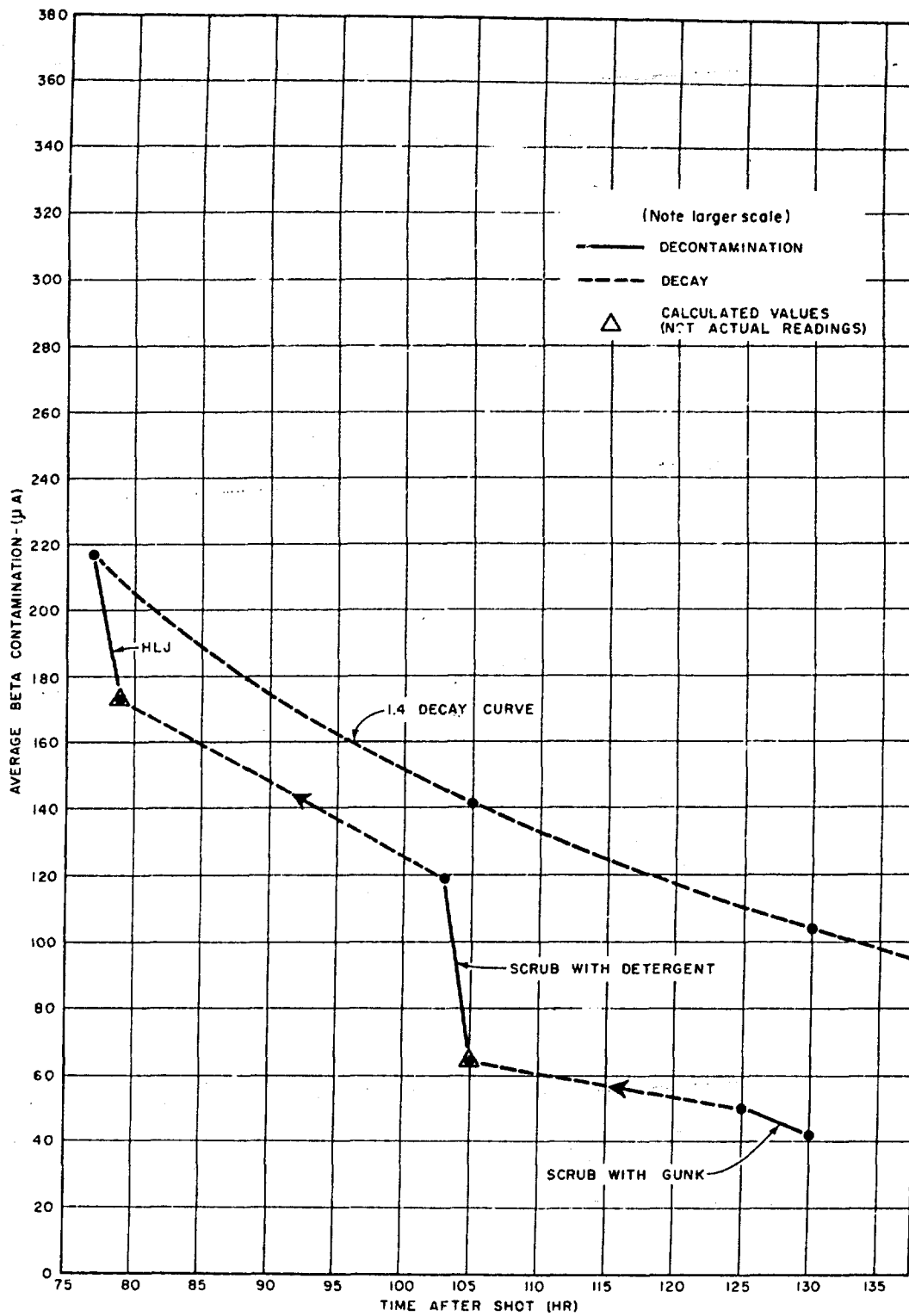

Figure D.26 Decontamination effectiveness for all operations on the aircraft aboard the YAG 39 after Shot 5.

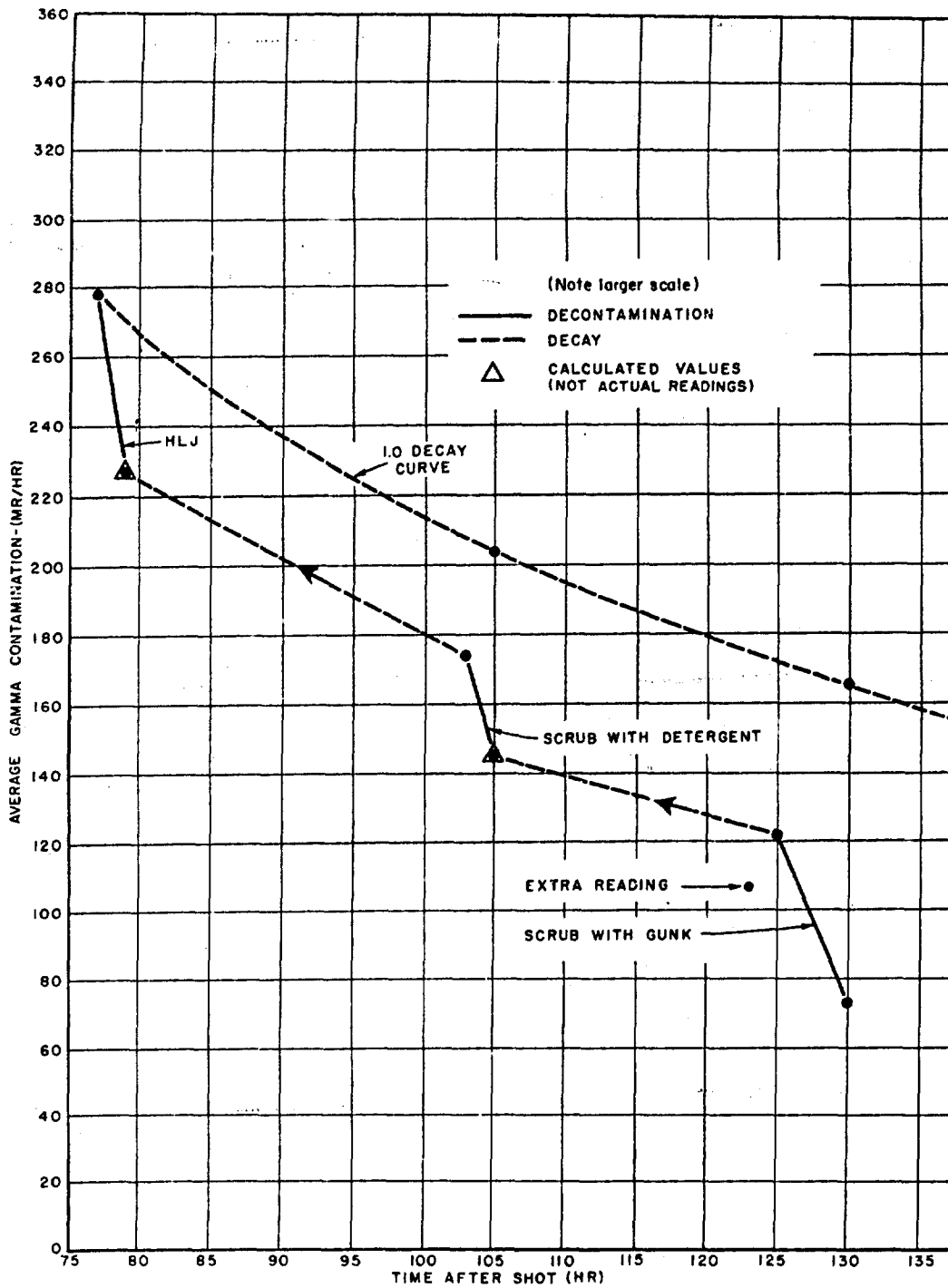

Figure D.27 Decontamination effectiveness for all operations on the aircraft aboard the YAG 39 after Shot 5.

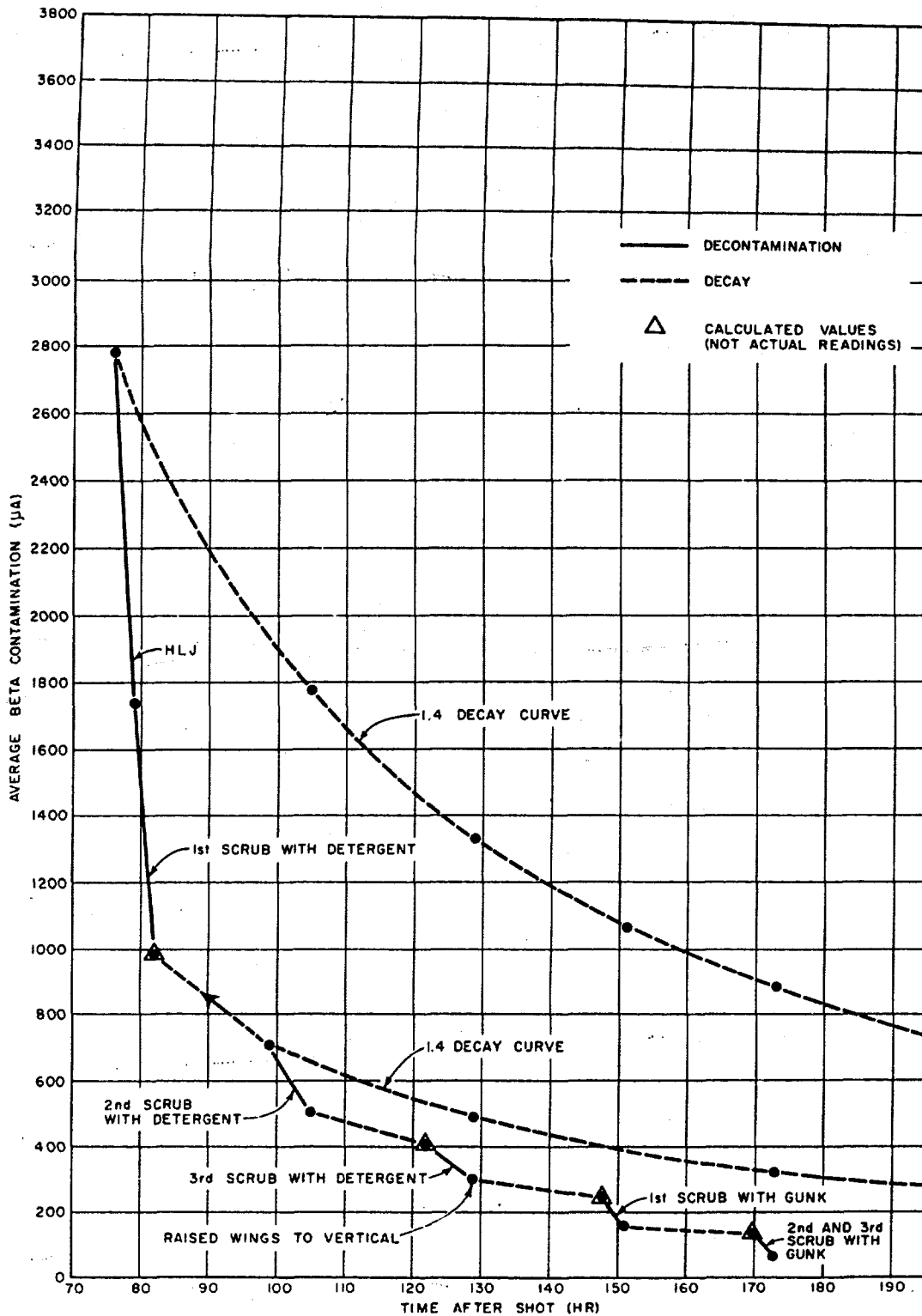

Figure D.28 Decontamination effectiveness for all operations on the aircraft aboard the YAG 40 after Shot 5.

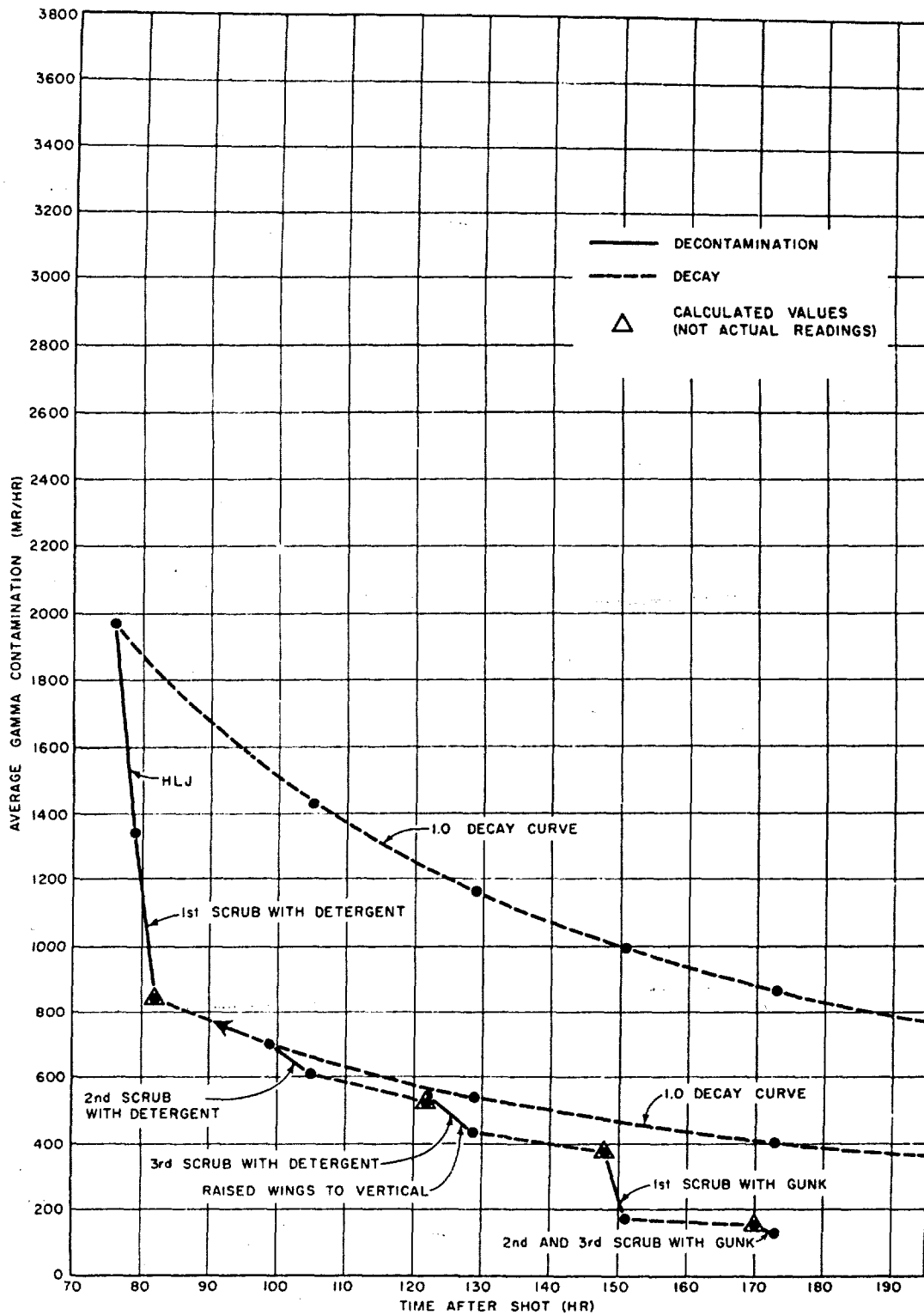

Figure D.29 Decontamination effectiveness for all operations on the aircraft aboard the YAG 40 after Shot 5.

- b. Kerosene, Spraying, 24 gal/hr  
Scrubbing, 8 gal/hr
- c. Fresh water to unit, 255 gal/hr
- d. Fresh water (steam generation), 30 gal/hr
- e. Fresh water (detergent solution), 8 gal/hr
- f. Detergent (C-120), 15 lb/hr
- g. Totals, Gunk, 4 gal/hr  
Kerosene, 32 gal/hr  
Fresh water, 293 gal/hr  
Detergent (C-120), 15 lb/hr

D.2.4 Comparison of Beta and Gamma Data. Gamma readings were taken with a fixed gamma recorder and with the gamma survey instruments. A comparison of the results of the decontamination of the aircraft on the YAG 40 after Shots 2 and 5 obtained by these two methods are given in Figures D.30 and D.31. With the exception of the first decontamination on the aircraft after Shot 2, the results obtained by these two methods correspond reasonably close through the entire decontamination efforts.

The close check of the results percentage-wise from the gamma-survey instruments and the fixed gamma recorder shows that either method gives reliable and reproducible results. It must be remembered that the gamma-survey-instrument readings are the average of 50 or more individual readings taken all over the aircraft surface, while the fixed gamma recorder data were obtained from a single instrument, located in the cockpit of the aircraft, which transmitted the data to the recorder located in the tent.

The discrepancy in beta and gamma percentage removal led to a further investigation of the ratio of beta survey readings in microcuries divided by the gamma survey readings in milliroentgen per hour.

The test plate data from Shots 4 and 5 were used in this study because the gamma readings did not have the high background readings as was the case with gamma readings taken on the aircraft. The data indicate that beta and gamma are removed at about the same percentage rate when the decontamination method is firehosing or washing with the hot-liquid jet. When the decontamination method is scrubbing with detergent or Gunk, the percentage of beta contaminant removed is greater than the percentage of gamma contaminant removed (see Tables D.13 and D.14 and Figures D.32 through D.36).

D.2.5 Contamination Distribution. Beta surveys were made on the aircraft aboard the YAG 40 after Shots 2 and 5 to determine the contamination distribution. See Tables D.15 through D.17.

The exact location of each monitoring location is shown on the aircraft diagrams, Figures D.37 and D.38. The numbers which are underlined were used only on the aircraft aboard the YAG 40 after Shot 2 to

designate monitoring locations for the initial beta and gamma survey while the aircraft was still on the ship. Numbers not underlined indicate the monitoring locations for the detailed surveys which were taken after both Shots 2 and 5.

TABLE D.13 BETA TO GAMMA RATIOS (a) FOR TEST PLATES ON YAG 40 AFTER SHOT 4

	Test Plate Nos.			Test Plate Nos.			Test Plate Nos.		
	1	2	3	4	5	6	7	8	9
Beta	100	136	155	161	137	172	159	162	135
Gamma	38.4	44.4	49.4	38.6	38.6	41.0	38.2	41.4	36.2
Ratio	2.61	3.07	3.14	4.16	3.54	4.19	4.27	3.91	3.72
Average		2.94			3.96			3.97	
Decon. Process	Hot Liquid Jet Salt Water			Fire Hose at 20 psi			Hot Liquid Jet Salt Water		
Beta	78	106	115	150	122	164	113	119	104
Gamma	29.2	34.0	34.8	36.2	35.4	37.2	28.0	28.8	25.0
Ratio	2.67	3.12	3.31	4.14	3.45	4.40	4.04	4.13	4.16
Average		3.03			4.00			4.11	
Decon. Process	Hot Liquid Jet Salt Water			Fire Hose at 20 psi			Scrubbing with Salt Water Rinse		
Beta	70	93	105	147	123	160	47	42	39
Gamma	29.6	34.0	35.2	34.4	34.0	35.8	14.6	13.4	12.4
Ratio	2.36	2.74	2.98	4.28	3.61	4.48	3.21	3.13	3.14
Average		2.69			4.12			3.16	
Decon. Process	Scrubbing with Salt Water Rinse			Scrubbing with Salt Water Rinse			Scrubbing with Salt Water Rinse		
Beta	32	40	42	42	29	44	43	43	31
Gamma	16.4	16.2	16.4	16.2	15.6	16.0	13.6	13.8	14.0
Ratio	1.95	2.47	2.56	2.59	1.86	2.75	3.16	3.12	2.21
Average		2.33			2.40			2.83	

(a) Ratio of Beta ( $\mu\text{c}$ )/Gamma (mr/hr).

TABLE D.14 BETA TO GAMMA RATIOS (a) FROM TEST PLATES ON YAG 40 AFTER SHOT 5

	Test Plate Nos.			Test Plate Nos.			Test Plate Nos.		
	1	2	3	4	5	6	7	8	9
Beta	8200	8800	7800	6000	5900	5500	4000	3700	3400
Gamma	2160	2300	1960	1620	1640	1440	1260	1500	1460
Ratio	3.79	3.82	3.98	3.70	3.60	3.82	3.18	2.47	2.32
Average		3.86			3.71			2.66	
Decon. Process	Hot Liquid Jet SW <sup>(b)</sup>			Fire Hose at 100 psi			Liquid Jet FW <sup>(c)</sup>		
Beta	5300	5600	5100	5800	5500	5000	3200	3300	3500
Gamma	1370	186	1370	1660	1720	1480	1080	1280	1280
Ratio	3.87	3.01	3.72	3.49	3.20	3.38	2.96	2.58	2.74
Average		3.53			3.26			2.76	
Decon. Process	Hot Liquid Jet FW			Fire Hose at 100 psi			Scrubbed with Gunk FW Rinse		
Beta	5600	5900	5500	5000	4600	4200	188	151	128
Gamma	1340	1600	1760	1320	1400	1260	116	136	128
Ratio	4.18	3.69	3.12	3.79	3.28	3.33	1.62	1.18	1.00
Average		3.66			3.47			1.27	
Decon. Process	Scrubbing with SW Rinse			Scrubbing with SW Rinse			Scrubbing with Gunk FW Rinse		
Beta	810	1300	1180	730	660	360	168	159	113
Gamma	304	432	398	372	352	254	79	90	78
Ratio	2.67	3.01	2.97	1.96	1.87	1.42	2.13	1.76	1.45
Average		2.88			1.75			1.78	
Decon. Process	Scrubbing with SW Rinse			Scrubbing with SW Rinse					
Beta	660	940	870	390	390	260			
Gamma	262	338	310	158	186	140			
Ratio	2.52	2.78	2.81	2.47	2.10	1.85			
Average		2.70			2.14				

(a) Ratio of Beta ( $\mu\text{c}$ )/Gamma (mr/hr).

(b) SW, Salt water.

(c) FW, Fresh water



TABLE D.15 BETA CONTAMINATION DISTRIBUTION AFTER SHOT 2

Monitoring Location	Position	Reading ( $\mu\text{c}$ )
Prop.	1	13,500
Engine	2	1,500
Eng. Cowl S	3	7,000
Air Cooler	4	6,000
L. Wing S	5	9,000
L. Wing S	6	7,750
Stub Wing S.	7	1,500
S. Fuselage S	8	4,500
Ver. Stab. S.	9	5,750
Hor. Stab. S	10	5,750
Hor. Stab. S	11	3,000
Hor. Stab. P	12	1,000
Hor. Stab. P	13	1,000
Ver. Stab. P	14	1,500
S. Fusel. P.	15	
Stub Wing P.	16	1,000
L. Wing P.	17	1,000
L. Wing P.	18	1,000
Air Cooler P.	19	
Eng. Cowl. P.	20	500

TABLE D.16 BETA CONTAMINATION DISTRIBUTION AFTER SHOT 2

Monitoring Location	Position	Reading ( $\mu\text{c}$ )
Prop.	1	10,500
Engine S.	2	1,500
Engine S.	3	11,000
U. Cowl. S.	4	10,500
L. Cowl. S.	5	4,000
Exh. S.	6	
Tire S.	7	2,500
U. Wing S.O.	8	8,000
U. Wing S.O.	9	14,500
L. Wing S.O.	10	15,000
L. Wing S.O.	11	11,000
Wing Root S.	12	
St. Wing S.	13	
St. Wing S.	14	
U. Wing S.I.	15	1,000
U. Wing S.I.	16	500
L. Wing S.I.	17	1,000
L. Wing S.I.	18	
T. Fusel.	19	2,000
S. Fusel. S.	20	3,000
S. Fusel. S.	21	8,500
Tail Wheel S.	22	1,000
Vert. Stab. S.	23	10,500
Vert. Stab. S.	24	12,000
Hor. Stab. S. Top	25	
Hor. Stab. S. Top	26	3,000
Hor. Stab. S. Under	27	500
Hor. Stab. P. Top	28	2,000
Hor. Stab. P. Under	29	500
Hor. Stab. P. Top	30	1,000
Ver. Stab. P.	31	4,750
Ver. Stab. P.	32	1,000
S. Fusel. P.	33	750
T. Fusel. P.	34	1,000
H. Fusel. P.	35	
T. Fusel. P. For.	36	500
Stub Wing P.	37	500
Stub Wing P.	38	500
U. Wing P.I.	39	
U. Wing P.I.	40	20,000 off scale
L. Wing P.I.	41	2,000
L. Wing P.I.	42	
Wing Root P.	43	1,000
U. Wing P.O.	44	
U. Wing P.O.	45	1,000
U. Wing P.O.	46	750
U. Wing P.O.	47	750
Exh. P.	48	
Tire Port	49	1,000
U. Cowl. Port.	50	500
L. Cowl. Port	51	500
Engine Port	52	2,500
Engine Port	53	1,000

TABLE D.17 BETA CONTAMINATION DISTRIBUTION AFTER SHOT 5

Monitoring Location <sup>(a)</sup>	Position	Reading ( $\mu$ c)
1st Propellor Blade-For.	1	10,750
2nd Propellor Blade-Aft.	1a	1,025
Engine-For. Star.	2	2,500
Engine-For. Star.	3	8,000
Eng. Cowl. Upper-Star.	4	3,150
Eng. Cowl. Lower-Star.	5	3,000
Exhaust-Starboard	6	3,000
Tire-Star.	7	4,500
Wing-Upper Star. Out.	8	2,225
Wing-Upper Star. Out.	9	2,250
Wing-Lower-Star. Out.	10	2,000
Wing-Lower-Star. Out.	11	2,750
Wing Root-Star.	12	1,300
Stub Wing-Star.	13	1,250
Stub Wing-Star.	14	3,000
Wing Upper Star. In.	15	1,150
Wing Upper Star. In.	16	2,750
Wing Lower Star. In.	17	1,100
Wing Lower Star. In.	18	1,650
Fusel. Upper-Star-Upper	19	1,850
Fusel. Mid. Star. Aft.	20	950
Fusel. Mid. Star. Aft	21	1,125
Tail Wheel-Star.	22	700
Vent. Stab. Star.	23	1,125
Vent. Stab. Star.	24	775
Hor. Stab. Star. Top.	25	3,100
Hor. Stab. Star. Top.	26	1,675
Hor. Stab. Star. Under	27	475
Hor. Stab. Part Top	28	1,650
Hor. Stab. Part Under	29	1,350
Hor. Stab. Part Top	30	4,750
Vert. Stab. Port	31	1,100
Vert. Stab. Port	32	1,300
Fusel. Mid-Port-Aft	33	1,700
Fusel. Upper-Port-Aft	34	1,750
Fusel. Lower-Port-Aft	35	1,600
Fusel-Upper-Port-For.	36	2,250
Stub Wing-Port	37	3,500
Stub Wing-Port	38	3,000
Wing-Upper-Port-In.	39	350
Wing-Upper-Port-In.	40	775
Wing-Lower-Port-In.	41	325
Wing-Lower-Port-In.	42	575
Wing Root Port	43	900
Wing-Upper-Port-Out.	44	6,750
Wing-Upper-Port-Out.	45	3,750
Wing-Lower-Port-Out.	46	5,250
Wing-Lower-Port-Out.	47	3,250
Exhaust Port	48	4,000
Tire-Port	49	1,300
Engine Cowl-Upper-Port	50	3,000
Engine Cowl-Lower-Port	51	1,450
Engine-For. Port	52	11,000
Engine-For. Port	53	5,250

(a) See Airplane Diagrams for more details.  
Readings taken 0950-1030 5/8/54.

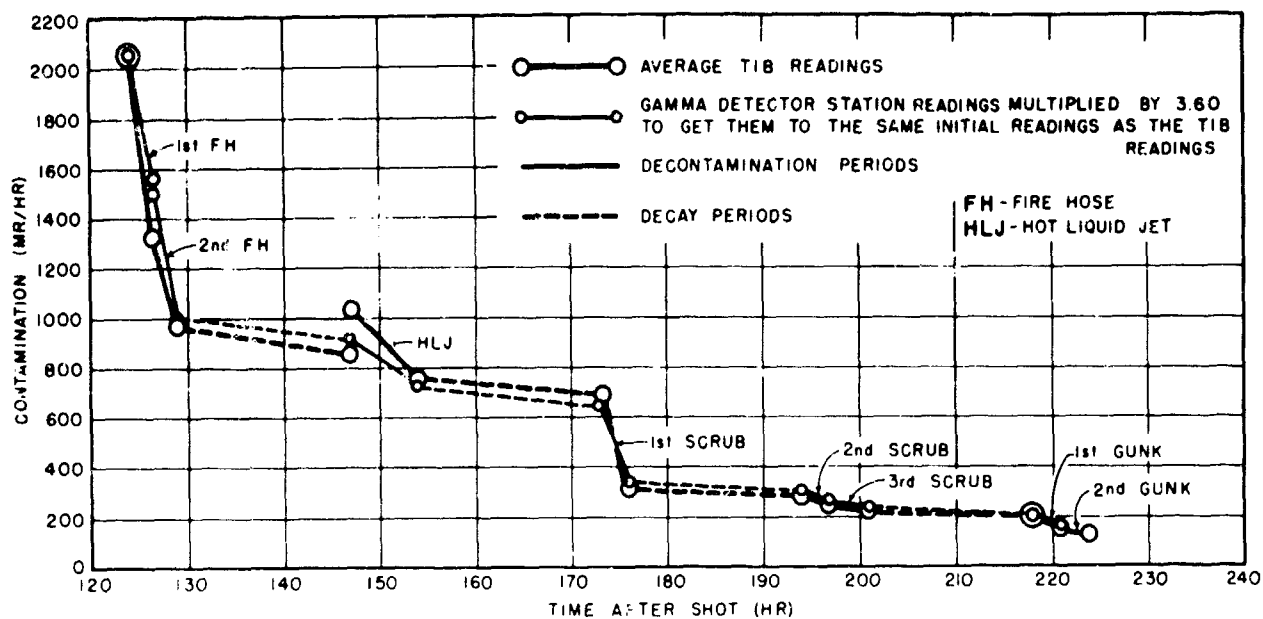

Figure D.30 Comparison of average T1B versus fixed gamma readings for aircraft aboard the YAG 40 after Shot 2.

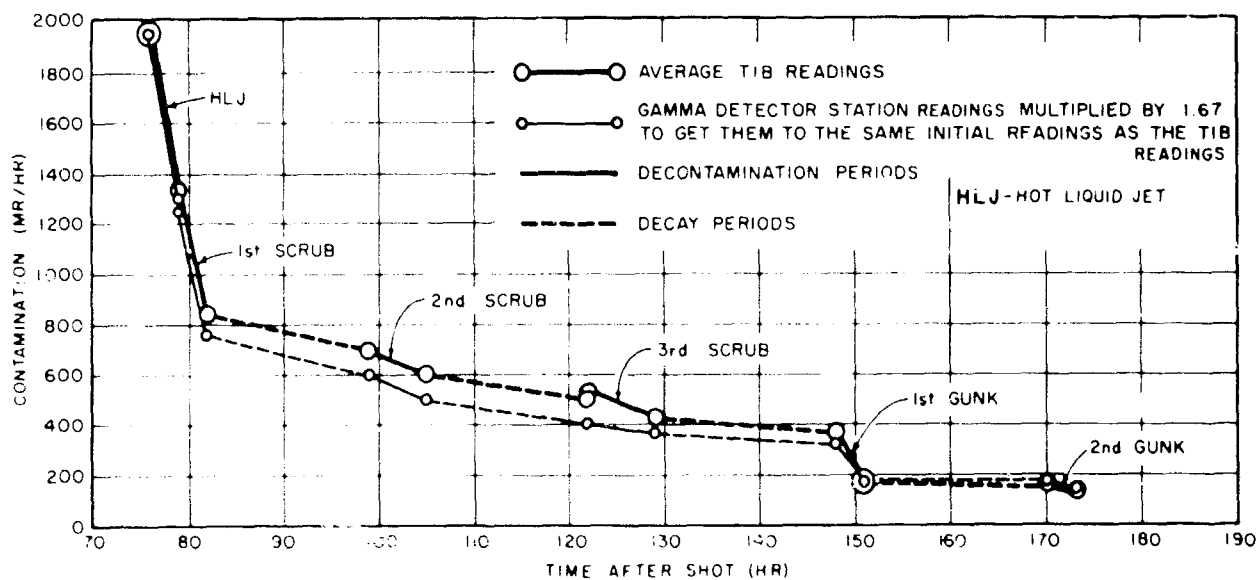

Figure D.31 Comparison of average T1B versus fixed gamma readings for aircraft aboard the YAG 40 after Shot 5.

CONFIDENTIAL

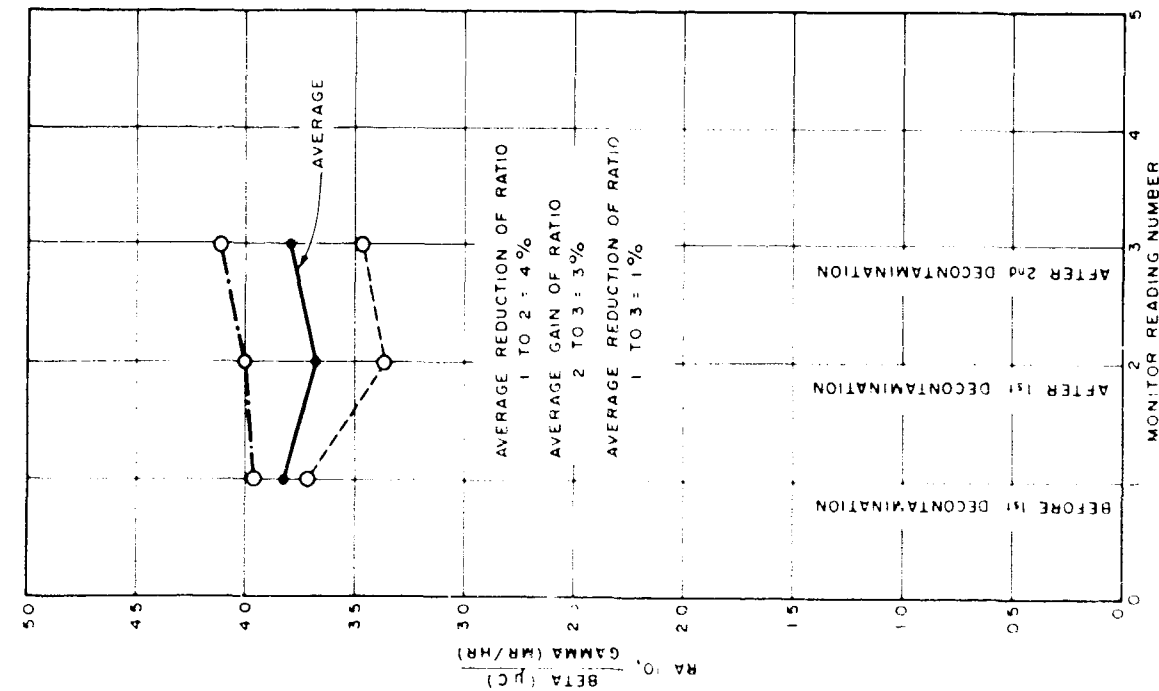

Figure D.32 Reduction of the beta-to-gamma ratio on test plates by washing them with the firehose.

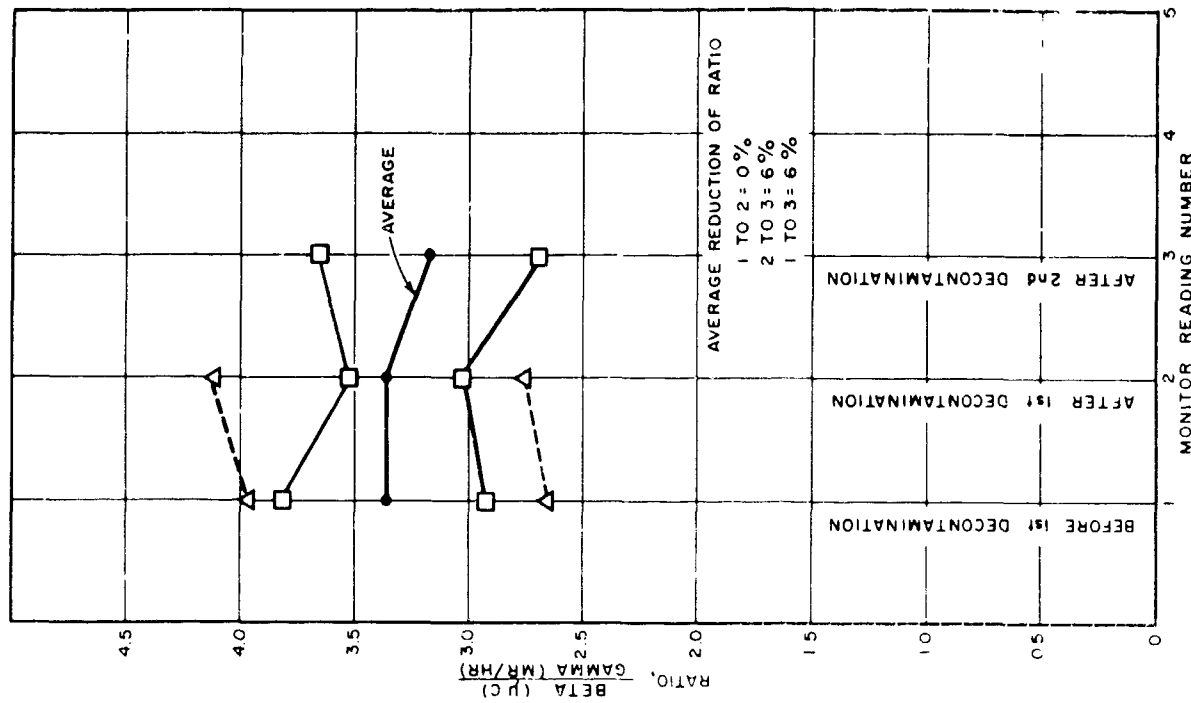

Figure D.33 Reduction of the beta-to-gamma ratio on test plates by washing them with the hot-liquid jet.

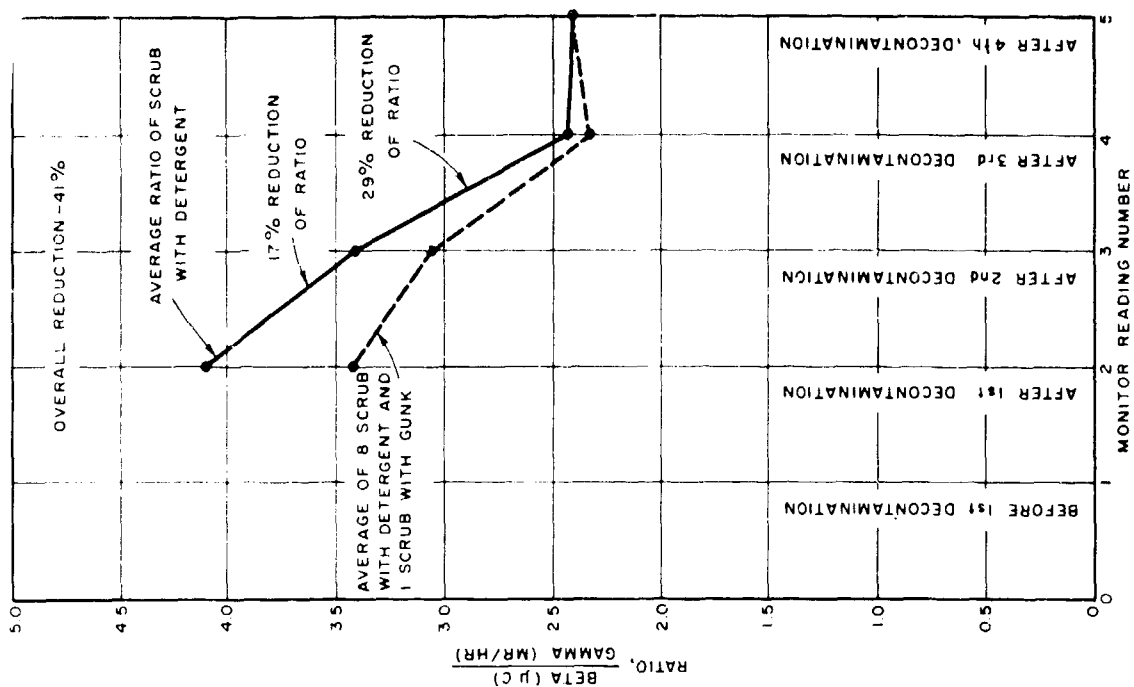

Figure D.35 Reduction of the beta-to-gamma ratio on test plates by scrubbing them with detergent and rinsing.

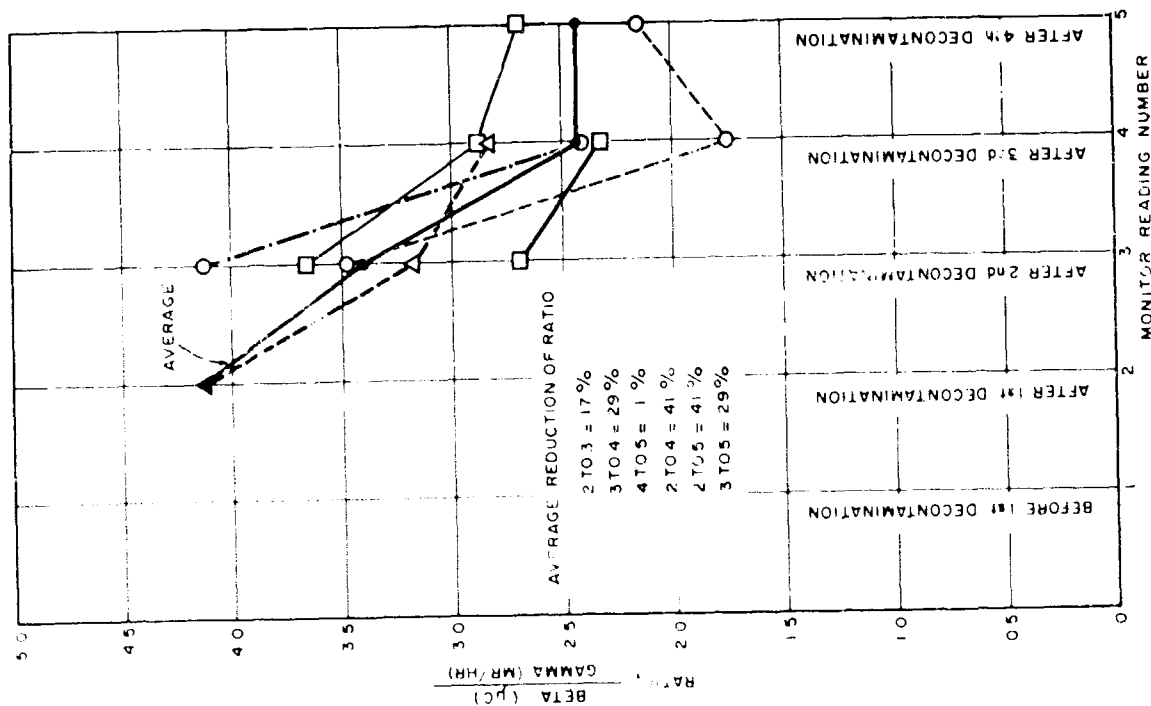

Figure D.34 Reduction of the beta-to-gamma ratio on test plates by scrubbing them with detergent and rinsing.

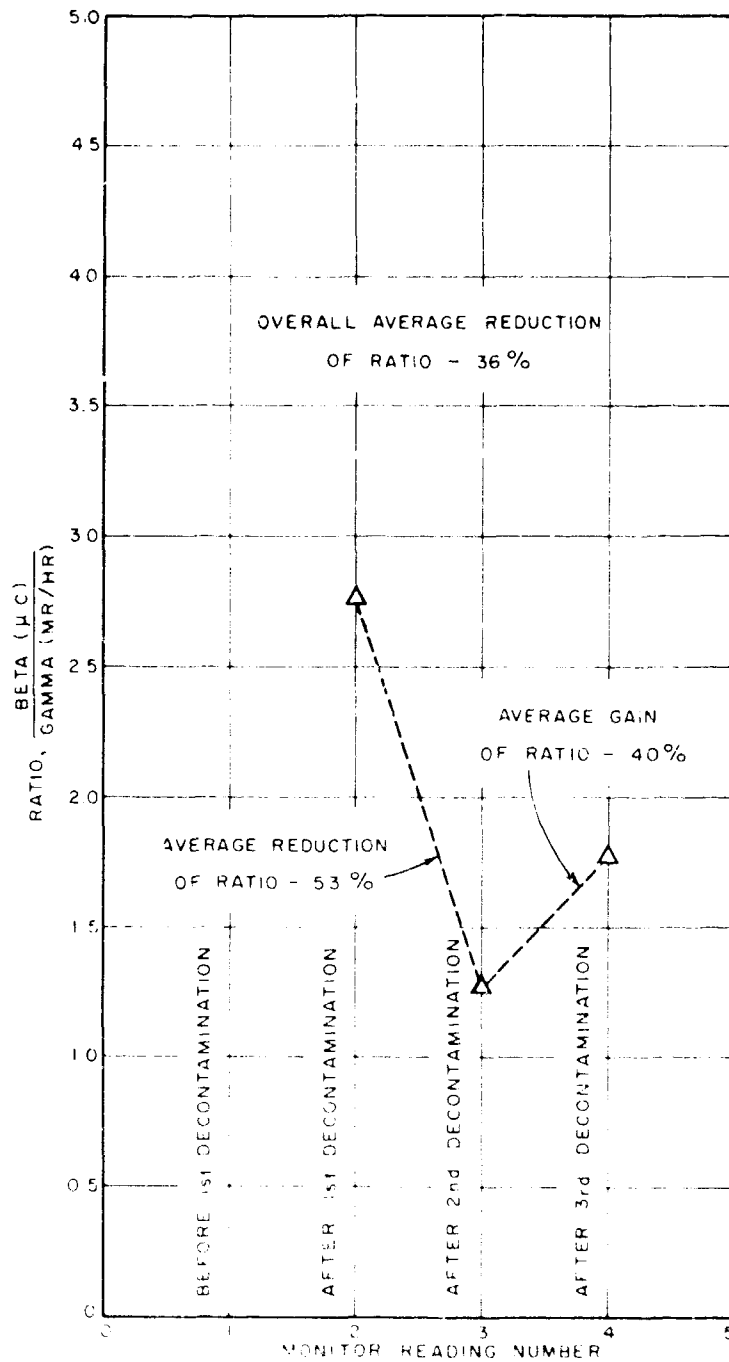

Figure D.36 Reduction of the beta-to-gamma ratio on test plates by scrubbing them with Gunk.

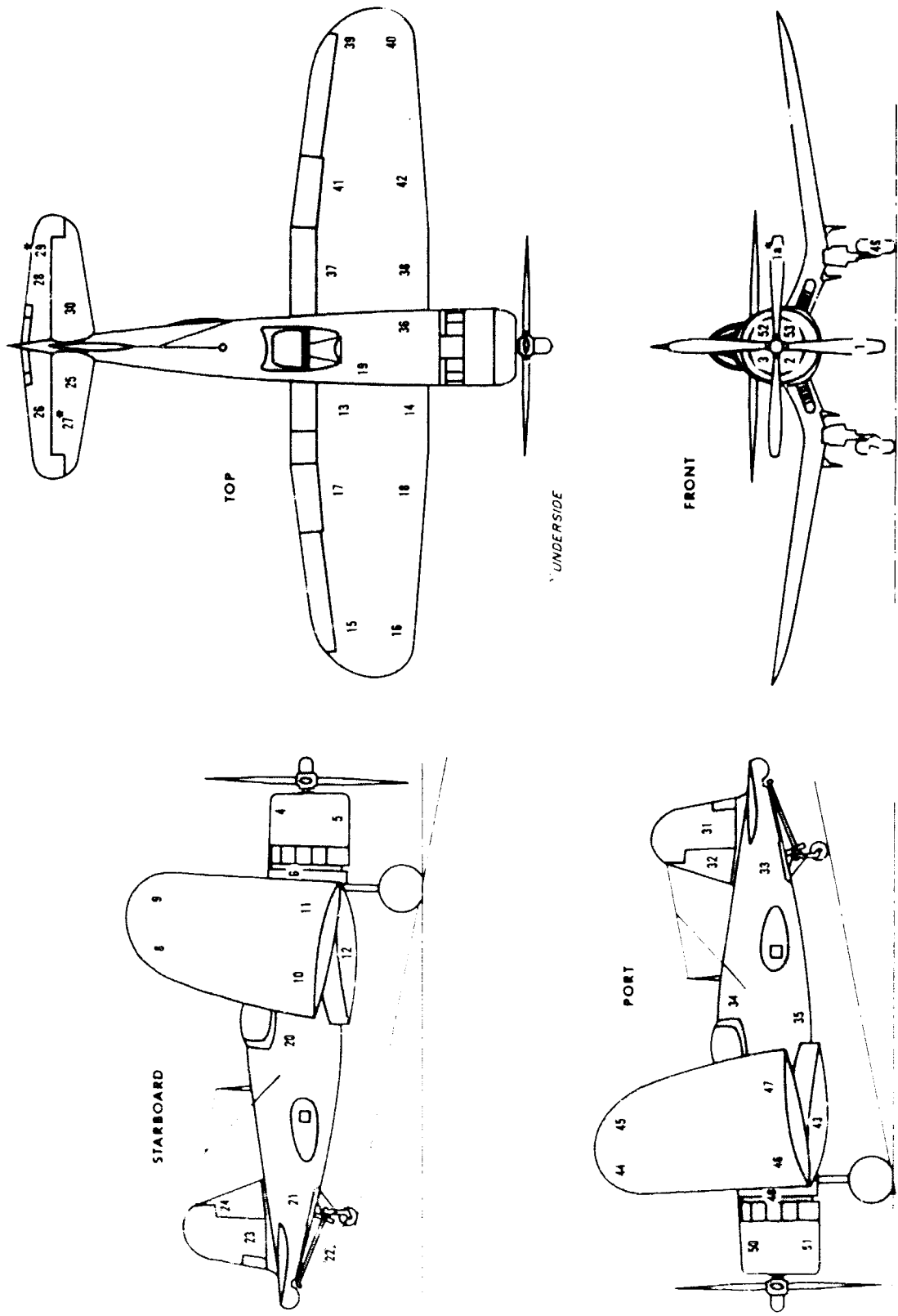

Figure D.37 Location of regular monitor stations on the aircraft.

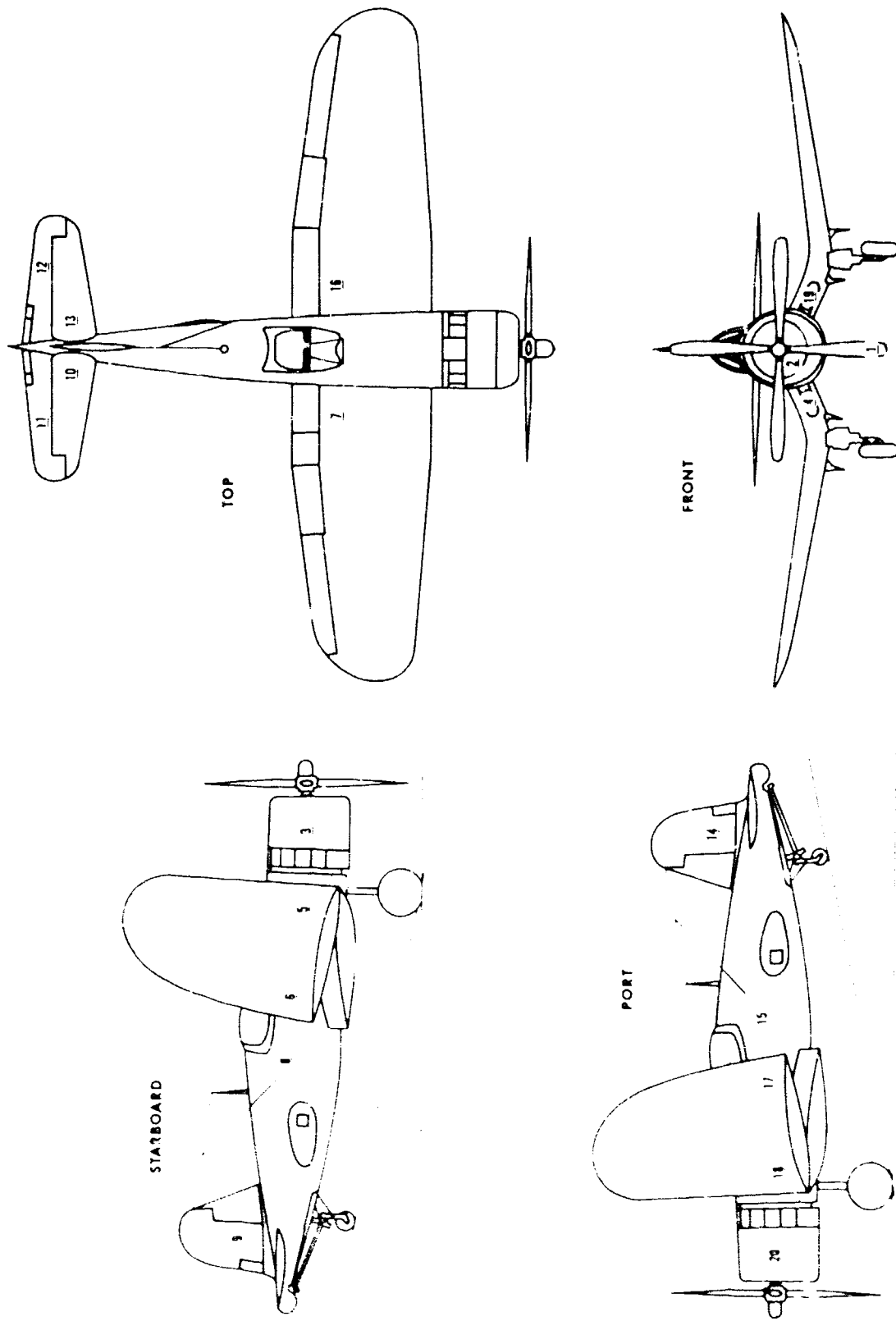

Figure D.38 Locations of special monitor stations for Shot 2 initial survey for contaminant distribution.



## Appendix E

# SUPPLEMENTARY MATERIAL ON SHIPBOARD INTERIOR CONTAMINATION

### E.1 FLOW STRUCTURE

In this treatment of flow structure, consideration is given to air-flow characteristics in the ventilation and boiler-air systems, as well as the auxiliary parameters, temperature, relative humidity, and barometric pressures.

E.1.1 Airflow Characteristics. Primary constituents of the ventilation ducts are summarized in Table E.1.

Airflow-volume rates in the ventilation ducts on the YAG 39 and YAG 40 were determined prior to the test from measurements made with the sampling cones in place. The flow rates were derived from pitot traverses where the velocities at a series of positions across a centerline in one plane of each of the ducts were measured as velocity pressure (inches of water) on an Ellison Draft Gage. Corrections for the local temperature, pressure, and humidity were made from a table of velocities of air at standard temperature, pressure, and given humidity versus the velocity head in inches of water; the flow rate was determined from the known cross-sectional area at the pitot traverse. Traverse stations were located downstream of the combination heater. Exact location of pitot taps were shown in Figure 6.4. The parallel plate structure of the heaters acted as a flow straightener. Three pitot taps were set 60° apart from each other around the circumferences of the ducts to provide an accurate three-dimensional traverse of the flow contours at each station; however, two traverses per station were generally sufficient. Air velocity contours for each of the six systems are shown in Figure E.1.

Each system had been balanced to obtain approximately the desired flow rate prior to the flow determination. Balancing was done by inserting orifices in the intake duct ahead of the wye branches. The flow rates are given in Table E.2

During each test the flow rate in each ventilation system was checked for variation from that in the calibration run with a Hays recorder, which gave a continuous recording of the static pressure differential between two static pressure taps. It may be noted that three static taps are shown for the various systems in Figures 6.4 and 6.5; the two taps that gave the maximum scale reading within the limits of the pressure differential recorders were selected from each system for connection to a recorder. In general, flow was uniform through each system, but variations from the calibration run were observed. Variations from the calibration run are given in Table E.3

The Westinghouse precipitron was installed on board the YAG 40 as one of the ventilation countermeasures to be tested. The installation was made by the Mare Island Naval Shipyard according to the

TABLE E.1 SUMMARY OF VENTILATION DUCT CONSTITUENTS

Cubicle	Type Fan	Type Preheater (not operated)	Type Reheater (not operated)	Vents		Cubicle Terminal	Duct Wall Thickness <sup>(a)</sup> (in.)	Duct Diameters		cfm for which Designed
				Intake	Exhaust			Intake (in.)	Exhaust (in.)	
Condition I, YAG 40	ALA4W5 intake and exhaust	26M	26H	mush-room size 10	mush-room size 8	7-in. diffuser	0.125	8 to 7 branches	8 ahead of exhaust fan 7 after fan	670
Condition II, YAG 40	ALA4W5 intake and exhaust	26M	26H	mush-room size 10	mush-room size 8	7-in. diffuser	0.125	8 to 7 branches	8 ahead of exhaust fan 7 after fan	1000
Condition III, YAG 40	ALA4W5 intake and exhaust (not operated)	26M	26H	mush-room size 10	mush-room size 8	7-in. diffuser	0.125	8 to 7 branches	8 ahead of exhaust fan 7 after fan	1000
Condition IV, YAG 40	ALA4W5 intake and exhaust	26M	26H	mush-room size 10	mush-room size 8	7-in. diffuser	0.125	8 to 7 branches	8 ahead of exhaust fan 7 after fan	1000
Condition V, YAG 40	ALA4W5 intake and exhaust	26M	26H	mush-room size 10	mush-room size 8	7-in. diffuser	0.125	8 to 7 branches	8 ahead of exhaust fan 7 after fan	1000
Condition VI, YAG 40	ALA4W5 intake and exhaust	26M	26H	mush-room size 10	mush-room size 8	7-in. diffuser	0.125	9 1/2 to 7 branches	8 ahead of exhaust fan 7 after fan	1000
Condition IIA, YAG 39	ALA4W5 intake and exhaust	26M	26H	mush-room size 10	mush-room size 8	7-in. diffuser	0.125	8 to 7 branches	8 ahead of exhaust fan 7 after fan	1000

(a) Duct material was galvanized steel.

specifications from the Naval Research Laboratory; a Westinghouse representative checked the installation. Prior to departure for the test site, NRL representatives made final modifications preparatory to the field tests.

All the available data on the operation of the precipitron are included in Table E.4.

On reboarding the ship after 27 March 1954, one filter was removed and read with a TLB on board ship in a background of 25 mr/hr. The reading was 30 mr/hr; so the filter was replaced, since this reading was comparable to the background and there was no dirt visible. The maximum reading on the outer housing of the precipitron was 500 mr/hr, with an average of about 300 mr/hr. The average reading along the interior wall of the precipitron housing was about 35 mr/hr, though the extent of the

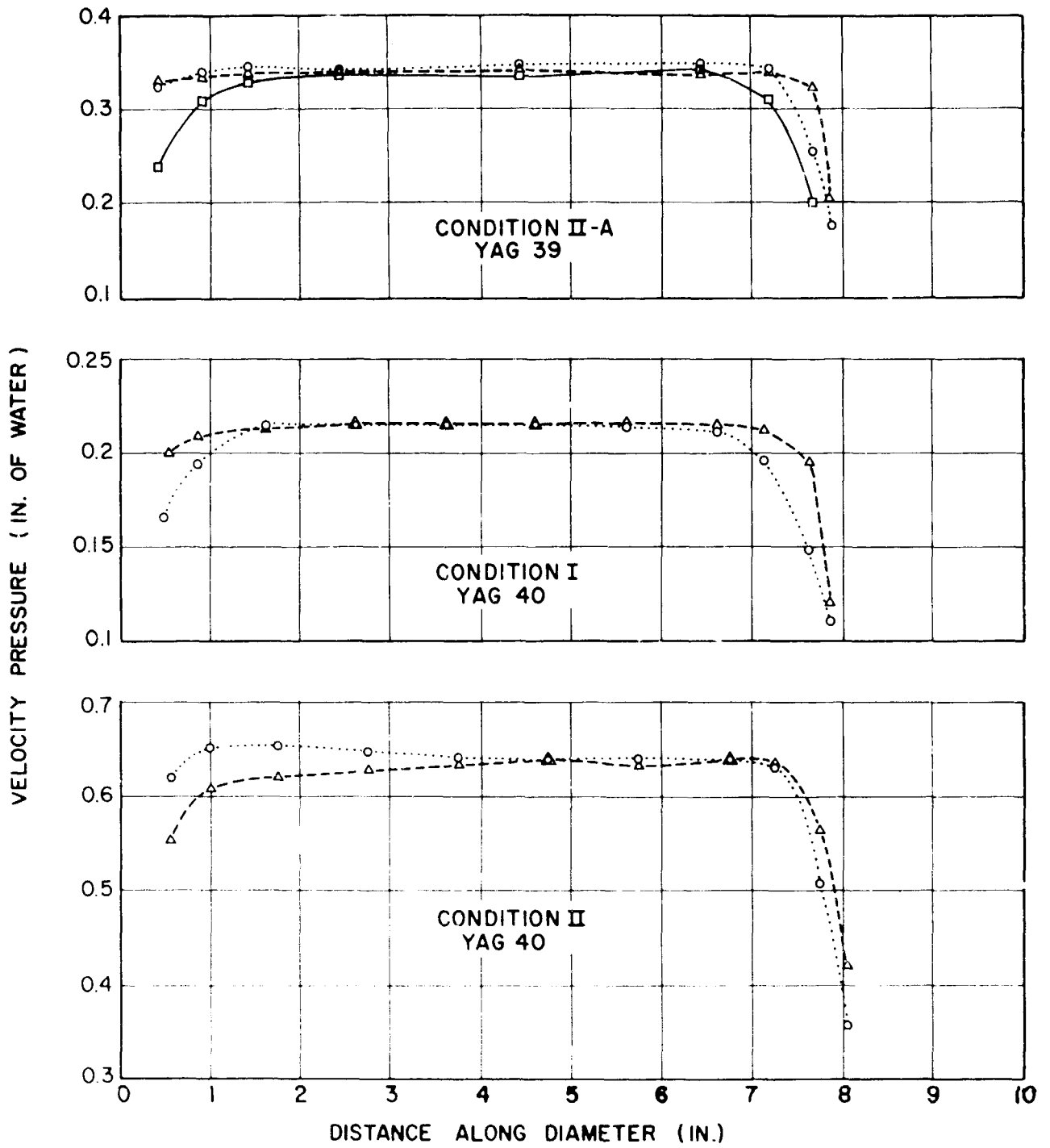

Figure E.1 Pitot traverses for the (6) six test conditions.

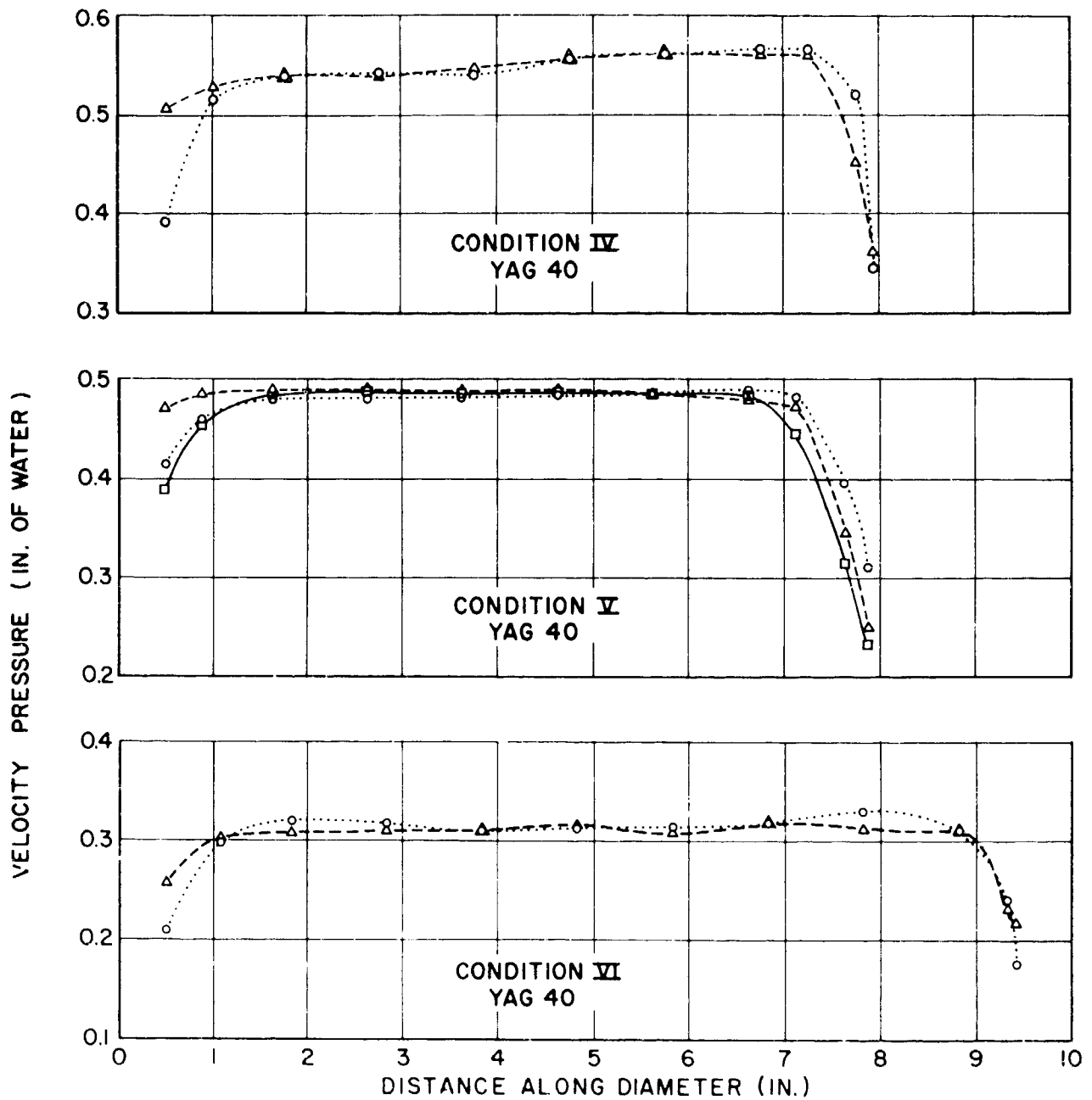

Figure E.1 (Cont.) Pitot traverses for the (6) six test conditions.

TABLE E.2 FLOW RATES THROUGH THE DUCTS

Cubicles	Measured Mean Velocity <sup>(a)</sup> (ft/min)	Duct Dia. (in.)	Flow Rate (cfm)
Condition I, YAG 40	1,829	8	638
Condition II, YAG 40	3,190	8	1113
Condition III, YAG 40	-	8	-
Condition IV, YAG 40	2,949	8	1029
Condition V, YAG 40	2,735	8	955
Condition VI, YAG 40	2,273	9.5	1118
Condition IIA, YAG 39	2,311	8	807

(a) Values corrected to the following conditions:  
cubicle temperatures, 81.5° to 87°F  
barometric pressure, 29.42 to 29.70 in. of Hg  
relative humidity, 74 percent

contribution to this reading from the activity on the exterior of the housing is unknown.

**E.1.2 Boiler-Airflow Characteristics.** Four pitot taps were spotted around the perimeter of each boiler air duct 38 in. ahead of the expansion section above the forced draft blower. These taps were stationed to provide four traverses at 45° to each other in each duct for each dial speed of the ship; however, only three traverses per dial speed were made on YAG 39. Space limitations prevented the straight section ahead of the forced draft blower from being more than six duct diameters in length. The requirements of flow measurement were compromised still further by the sharp turn of the airstream upon entering the blower housing. Flow straightening devices were avoided for fear of inserting too many non-typical deposition surfaces into the airstream. Nevertheless, two sets of turning vanes were installed--below the simulated armor grating and in the elbow at the top of the intake duct.

Pitot traverse plots are shown in Figures E.2 and E.3. The patterns are irregular, but they are superior to those available anywhere else in the boiler-air systems. On the basis of these measurements, flow rates at various dial speeds were computed (Table E.5). The ships' speeds corresponding to the various dial settings are not accurate. They are expected values since no calibration was made.

Pressure differential recorders were set up to record the differences in static-pressure drops between two taps located between the uptake

TABLE E.3 STATIC PRESSURE DEVIATIONS FOR SHOTS 2, 4 and 5

	P. for Shot/P. for Calibration		
	Shot 2	Shot 4	Shot 5
Condition I, YAG 40	1.000	1.022	1.000
Condition II, YAG 40	1.012	0.975	0.960
Condition IV, YAG 40	1.000	0.952	0.965
Condition V, YAG 40	-(a)	0.965	0.965
Condition VI, YAG 40	1.028	1.041	1.041
Condition IIA, YAG 39	1.000	-(a)	0.990

(a) No flow

TABLE E.4 PRECIPITRON OPERATIONS

Date	Time of Observation	Cumulative Arcs	Arcs Since Last Observation	Cumulative Operating Time (hr)	Operating Time Since Last Observation (hr)	Remarks
27 Jan. 54	0800	18,746		221.6		At end of washing cycle.
29 Jan. 54	1435	19,242	496	248.9	7.3	
16 Feb. 54	0739	25,960	6,718	301.1	52.2	Cleaned on 15 Feb. 54
16 Feb. 54	1445	26,129	169	308.2	7.1	
16 Feb. 54	1515	26,129	0	308.7	0.5	
16 Feb. 54	1610	26,129	0	309.6	0.9	
22 Feb. 54	0314	26,788	659	328.4	18.8	During last dry run
22 Feb. 54	1100	26,828	40	336.2	7.8	After dry run
1 Mar. 54	0330	28,056	1,228	347.9	11.7	
27 Mar 54	0305	29,031	975	395.8	47.9	
26 Apr. 54	0240	32,504	3,473	660.5	264.7	Precipitron cleaned prior to 26 April but filters not changed.
5 May 54	0215	32,504	0	754.9	84.4	Precipitron cleaned and filters changed 2 May.
30 May 54	0900	32,504	0	812.1	57.2	Shot day.

spaces and the forced draft blowers of the two test ships. Both recorders on YAG 39 and YAG 40 failed during Shot 5 and that on YAG 39 failed during Shot 4. From the remaining records the average flow rates in Table E.5 were derived. It must be noted that these values apply only during the time the power-driven samplers were operating, since the pressure-differential recorders were on the same timed circuit as the sampling instruments.

Air velocity measurements were made at air sampler stations in the combustion air ducts of YAG 40 to permit adjustment of those units to isokinetic flow. A single velocity-pressure measurement was made at each station just ahead of the cone intake. Table E.7 presents the results.

### E.1.3 Temperature, Relative Humidity, and Barometric Pressure. Rec-

TABLE E.5 BOILER AIRFLOW CHARACTERISTICS FOR YAG 39 AND YAG 40

YAG 40				YAG 39			
Dial Speeds (a) or Settings	Ship's Speed (knots)	Mean Air Velocity (ft/min)	Flow Rate (cfm)	Dial Speeds (a) or Settings	Ship's Speed (knots)	Mean Air Velocity (ft/min)	Flow Rate (cfm)
4	6.7	592	6,560	4	6.7	806	8,950
6	8.9	730	8,100	6	8.9	940	10,420
8	11.0	903	10,000	8	11.0	1,081	12,000

(a) Speed ranges in which the ships could operate were determined by 8 throttle settings. Dial speeds 1 to 8 were available but principal operating speeds used settings 2, 4, 6, and 8.

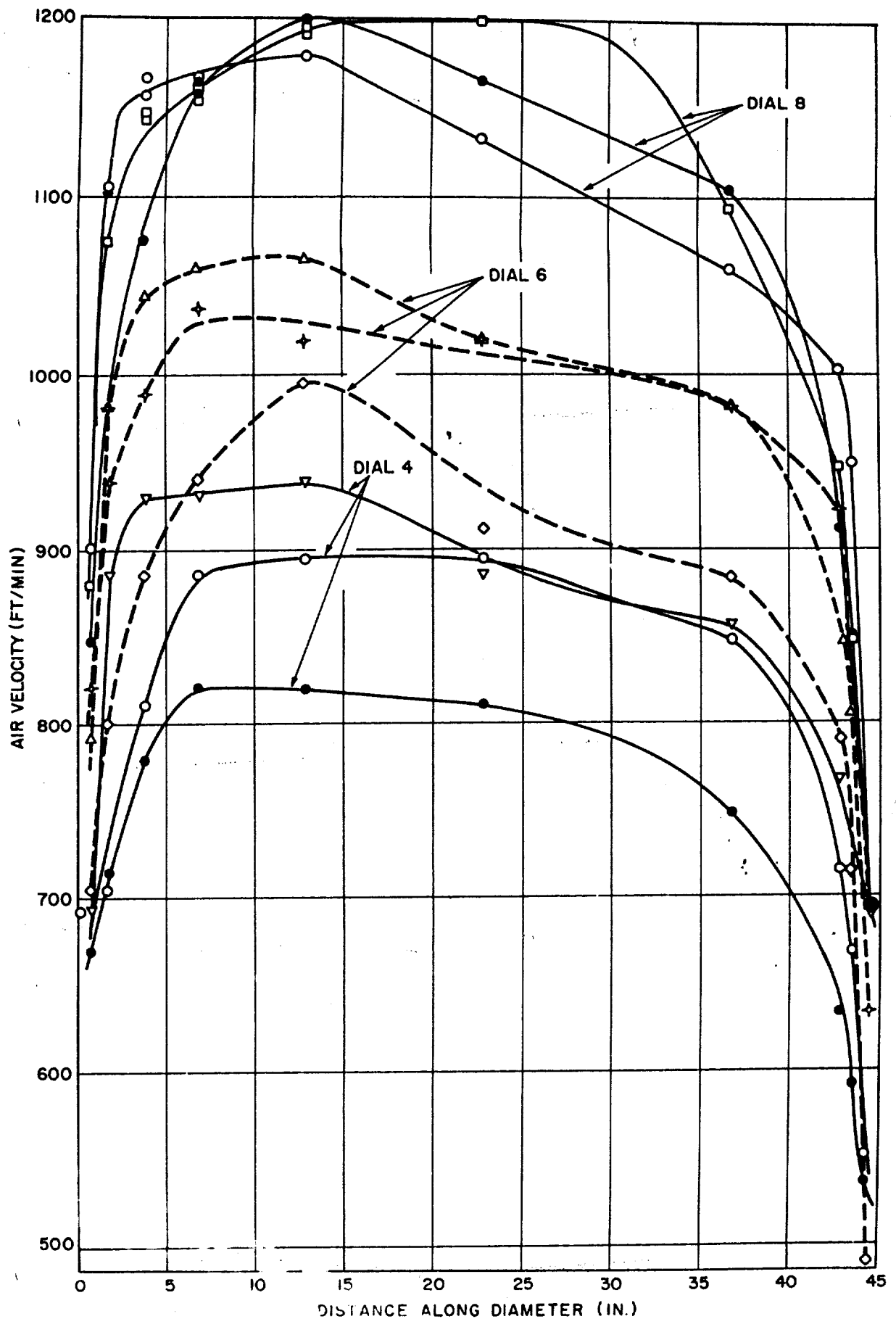

Figure E.2 Pitot traverses in boiler air intake duct of the YAG 39.

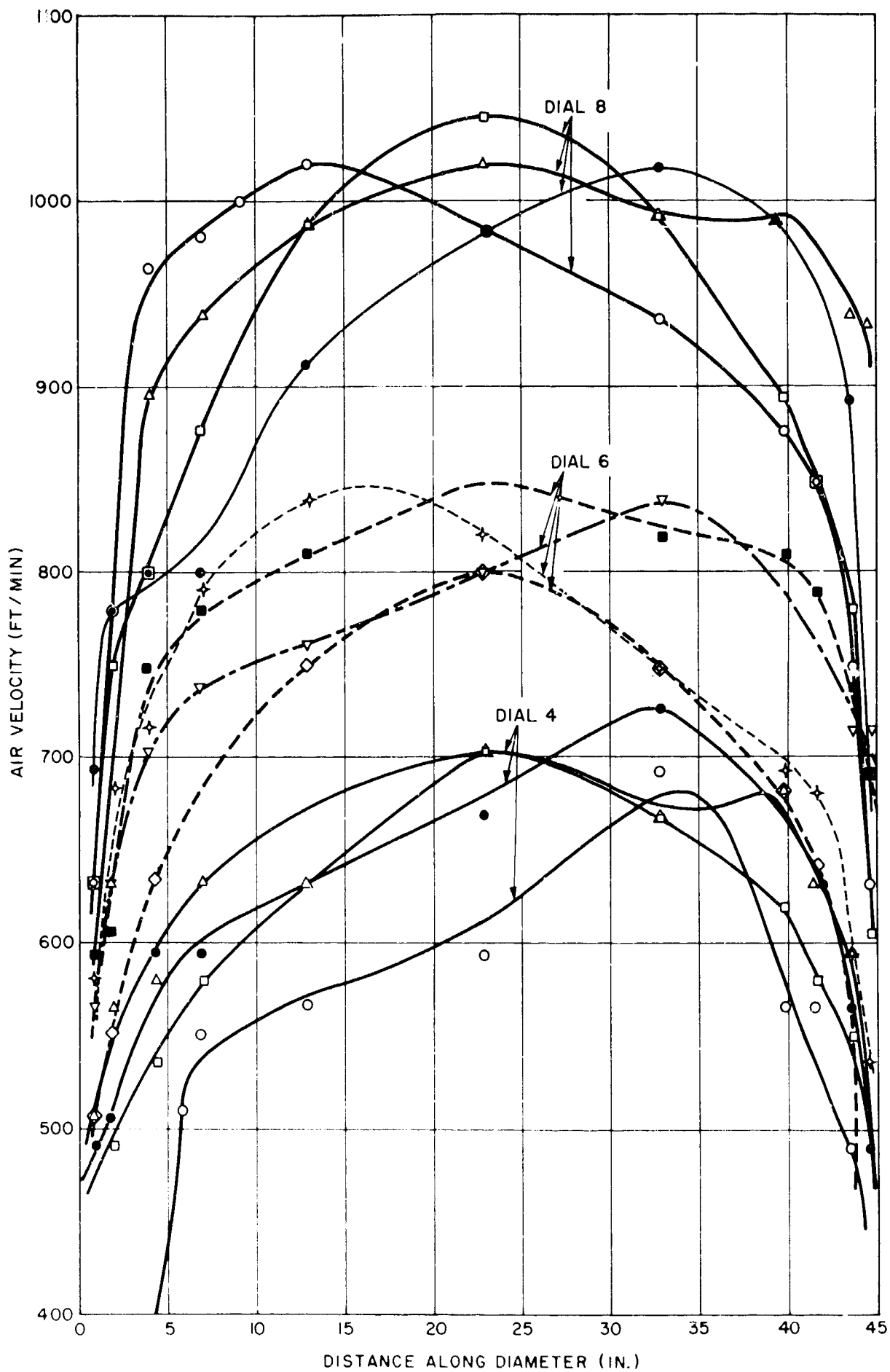

Figure E.3 Pitot traverses in boiler air intake duct of the YAG 40



TABLE E.6 AVERAGE BOILER AIR FLOW RATE (cfm)

	Shot 2	Shot 4	Shot 5
YAG 39	-	11400(a)	11400(a)
YAG 40	7380 from S to (S + 4 1/2 hr)	8800 from S to (S + 12 hr)	8800(a)

(a) The following assumptions were made:

- (1) Both ships stayed close together during Shots 4 and 5; therefore, they must have been operating at the same speeds.
  - (2) Both ships steamed at dial 6 or dial 8 during Shots 4 and 5
- A combination of the above assumptions and the approximate ratio of 1.3 between the one complete flow record of YAG 40, Shot 5 produced the marked values.

ords were made of the temperature in the ventilation test cubicles, at sampling stations in the boiler air systems, and at weatherside sampling stations. These data are given in Table E.8, together with measurements of relative humidity and barometric pressure.

## E.2 INSTRUMENTATION DETAILS

Details of the air sampler, particle collector, and suction unit, together with a discussion of their operational timing and performance are given in this section.

E.2.1 Air-Sampler Design. The continuous air sampler used for this investigation was required to operate under the following conditions: (1) where there were ambient air stream velocities ranging from 0 to 50 ft/sec; and (2) where there were ambient temperatures ranging from 60 to 475°F.

In addition, the sampler was designed, as closely as possible, to: (1) collect isokinetic samples whenever sampling a moving air stream; (2) sample continuously at a constant volume rate and constant filter paper speed for an 8-hr period; and (3) sample from a wet or dry atmosphere.

TABLE E.7 AIR VELOCITIES AT SAMPLING STATIONS IN YAG 40 BOILER AIR SYSTEM

	Speeds at Dial Settings (ft/min)		
	4	6	8
In duct beneath fiddley space	859	1060	1551
Starboard windbox downstream of forced draft blower	694	896	1266
Air duct connecting windboxes	694	1416	1602
Top of stack	-	-	630

TABLE E.8 TEMPERATURE, HUMIDITY, AND BAROMETRIC PRESSURE MEASUREMENTS  
FOR THREE SHOTS

YAG 40	YAG 39	Shot 2	Shot 4	Shot 5
		Temperature (°F)		
Top of deckhouse		78	80	79
Condition II		81	85	86
Condition III		83	87	89
Condition IV		82	86	87
Condition V		81	85	84
Condition VI		82	86	86
	Condition IIA	92	87	85
Between boilers		130	130	130
Fidley space		131	120	120
Starboard windbox		130	-	-
Port windbox		130	124	120
Ahead of forced draft blower		130	120	115
Stack top		330	390	390
	Between boilers	118	122	118
	Ahead of forced draft blower	110	116	115
	Top of No. 2 kingpost	90	90	85
	Weatherside relative humidity	96%	88%	75%
	Weatherside relative humidity	77%	Reading not taken	Reading not taken
	Barometric Pressure (in. of Hg)	29.5 max 29.25 min	29.55 max 28.95 min	Reading not available

The instrument consisted of the following basic elements: (1) a cone-shaped sampling inlet designed to allow isokinetic sampling while reducing the sampling velocity to a desired amount through the filter paper strip; (2) a feed system designed to pull the filter-paper strip past the sampling port at a constant speed; (3) an airtight case intended to prevent internal contamination and to permit no other flow into the sampler except that through the cone; and (4) a suction unit (Reference 17) to produce constant volume rate sampling through the filter paper.

There were two main types of sampler, hereinafter referred to as "long" and "short" samplers. The former were designed primarily to operate at temperatures above 100°F in the boiler air systems and the latter at temperatures up to 100°F in the ventilation systems (Figure E.4). Both types contained the same basic mechanisms.

The sample inlet was the small end of a 5.13° total angle diffuser cone designed to accomplish three things. It would make isokinetic sampling possible by reducing the air velocity of the ambient airstream to the sampling velocity at the filter-strip commensurate with the requirement that the drag force, caused by the pressure drop across the filter strip, be less than the tensile strength of the paper. It would make it possible to place sampling inlets in duct systems sufficiently far upstream from elbows so that sampling would not be done from areas of transitional air flow. Further, the cone would direct the flow of air sampled from the ambient airstream against the filter surface.

The filter paper feed system was designed to pull a strip of filter paper 5 in. wide and 270 ft long past a 3½-in.-diameter, pierced, stainless-steel sampling port at a constant speed. This was done by a synchronous motor geared through a five-speed gear box by sprocket and chain linkage

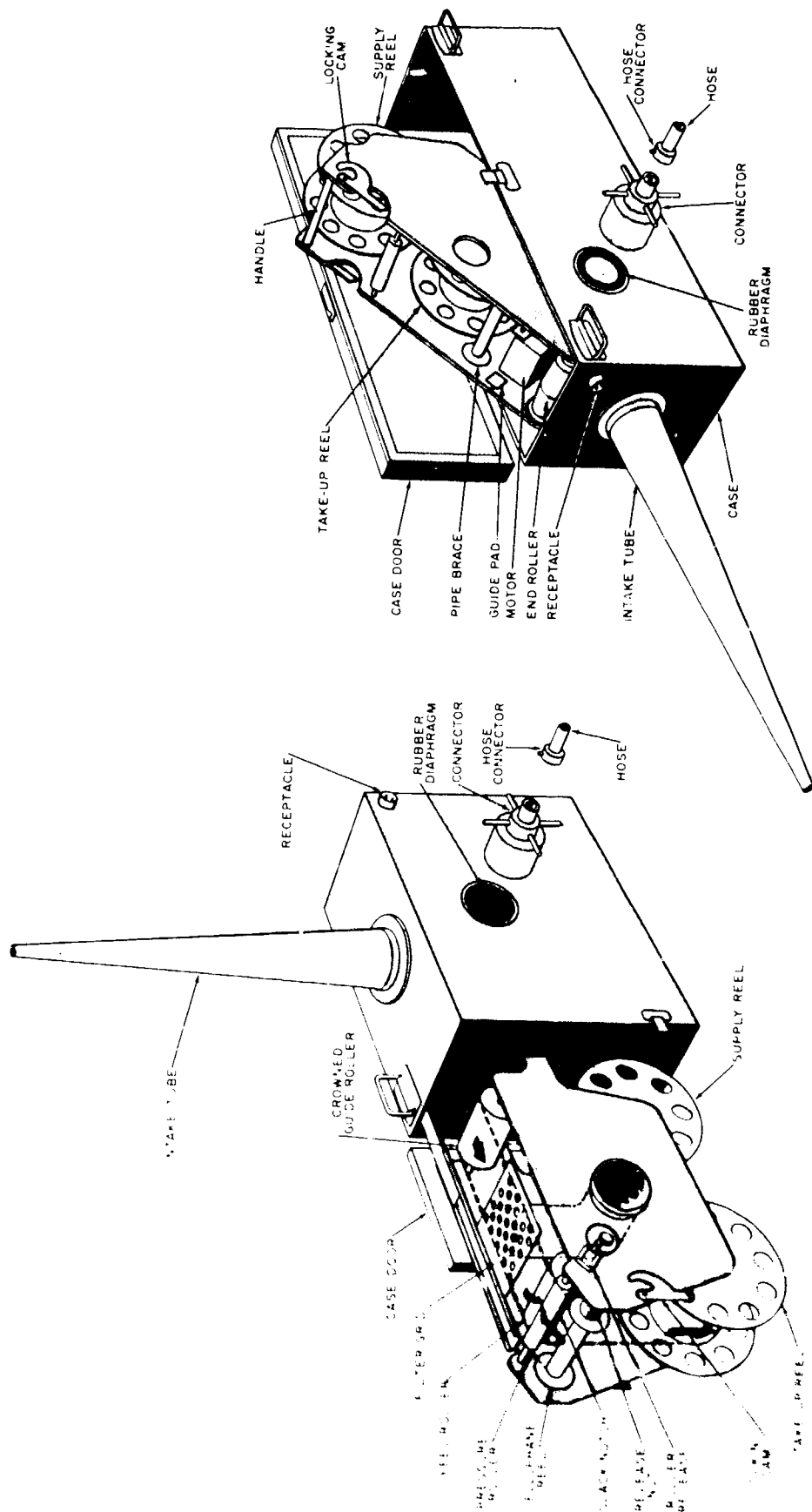

Figure E.4 Schematic of long- and short-type air samplers.

to a knurled aluminum drive roller in the long samplers and to a rubber-covered drive roller in the short samplers. The gear box allowed a choice of speeds in multiples of 2 from  $\frac{1}{4}$  to 4 in./min. The design of the drive rollers assured no slippage of the filter paper.

An aerosol incident at the cone intake was sampled with a lineal flow approximately equal to that of the aerosol stream. It was expected that a considerable fraction of the particulate matter would be deposited in the cone; so it was installed with a removable liner in such a manner as to give a clearance of approximately  $\frac{1}{4}$  in. between the cone and the filter strip to prevent tearing the latter. Since the aluminum case itself was airtight and the cone projected through a rubber diaphragm in the case, there was no air leakage. The face of the filter strip was protected by a covering strip 5 in. wide before passing through the drive rollers. In low-temperature conditions, the cover strip was cellophane; silicone-coated fibrous glass was used in the fire room. To prevent sagging of the filter strip after passing through the drive roller, a slot  $\frac{3}{16}$  in. wide was cut full length into each drive roller to allow the proper amount of covering strip to slide past with each revolution. In the sample collection, this feature caused a maximum error of 2 percent for any drive-roller revolution period. Each sample was retrieved after the operation as a filter strip with protective covering strip rolled onto a takeup reel and was sent back to the laboratory for analysis.

Extensive tests were made on various commercial filter papers during the design of the air sampler (Reference 25). MSA 1106B was chosen as having the best resistance to temperatures greater than room temperature combined with high efficiency and low pressure drop. This paper was used exclusively on the air samplers. Average pressure drop through the paper was estimated at 2.4 in. of Hg for a face velocity of 270 ft/min.

The sampling port was linked with the constant-volume-rate suction unit through a 90°,  $3\frac{1}{2}$ -in.-diameter, long-turn, brass elbow threaded to take a gasketed cadmium-coated brass reducing connector, which was removable for sample recovery. This connector in turn was linked to the suction unit by a 10-ft length of  $1\frac{1}{2}$ -in.-diameter flexible hose, or in the case of those located in the fireroom, through  $1\frac{1}{2}$ -in.-diameter pipe to the cold chest where the suction units were installed. The whole suction assembly had airtight integrity up to the sampling port, so there was no possibility of the sampled air being cycled through the case or bypassing the filter paper.

110-v alternating-current power to the synchronous motors and the suction units was furnished by a 60-KW motor generator system.

E.2.2 Molecular Filter Collector Design. Molecular filters furnished the optically transparent collecting surfaces required for particle sizing. For greater ease in processing and analysis, a dispersion on the order of 100 active particles per square millimeter is desirable. On the basis of estimates of percent of particles which would completely traverse the intake duct systems and estimates made of concentration of active particles in the air from Greenhouse and Buster Jangle report data (References 25 and 27), a flow ratio of 30 to 1 between collecting heads was selected; the total flow through both heads for each particle collecting unit was 10 cfm. If the estimate of active particulate concentration were correct, the desired flow rate to produce the preferred dispersion would be  $\frac{10 \text{ cfm}}{30}$ . To broaden the range of the instrument, this value was bracketed

by the high and low flow heads:

$$\frac{10 \text{ cfm}}{30} \times 30 = 10 \text{ cfm} = \text{high flow}$$

$$\frac{10}{30} \times \frac{1}{30} = \frac{1}{3} \text{ cfm} = \text{low flow}$$

This, then, would give an adequate sample for radioautography on one or the other of the two heads over a range of three decades (Figure E.5).

Power and timing for the units were identical to that of the continuous air samplers.

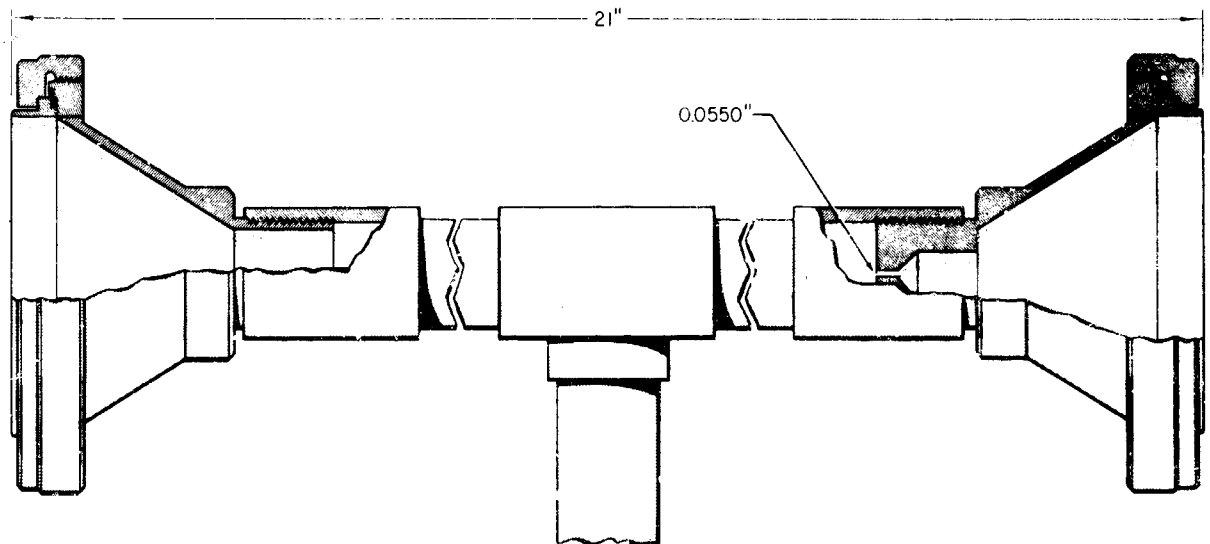

Figure E.5 Molecular filter collector

E.2.3 Suction Unit Details. Suction units Figure E.6 for particle collectors and air samplers were designed to maintain a constant flow through the collecting filter, regardless of changes in pressure drop through the filter. The units consisted of a Roots blower driven by an electric motor. Flow control was obtained through the presence of a vacuum-control valve ahead of the pump. This valve maintained a higher total pressure drop through the system than that of the test filter. As the pressure drop across the filter increased from loading of the filter, the valve opened to compensate. Flow could be controlled over a range of 0 to 8 in. of Hg.

Two types of suction units were used for this study. Those units which provide suction for air samplers were driven by a 3/4-hp variable-speed motor. This arrangement permitted a variation in flow rate over the range of 1 to 15 cfm, since it was considered that isokinetic sampling at the air-sampler stations could be best accommodated by changing the sampler intake flow rate to meet changes in duct air or wind speeds. The suction units associated with the molecular filter particle collectors differed only in that the motors were 1-hp constant-speed units coupled to the pumps with belt drives. These units were designed to draw a constant 10 cfm.

Both types had the common features of a flow recorder, control vacuum

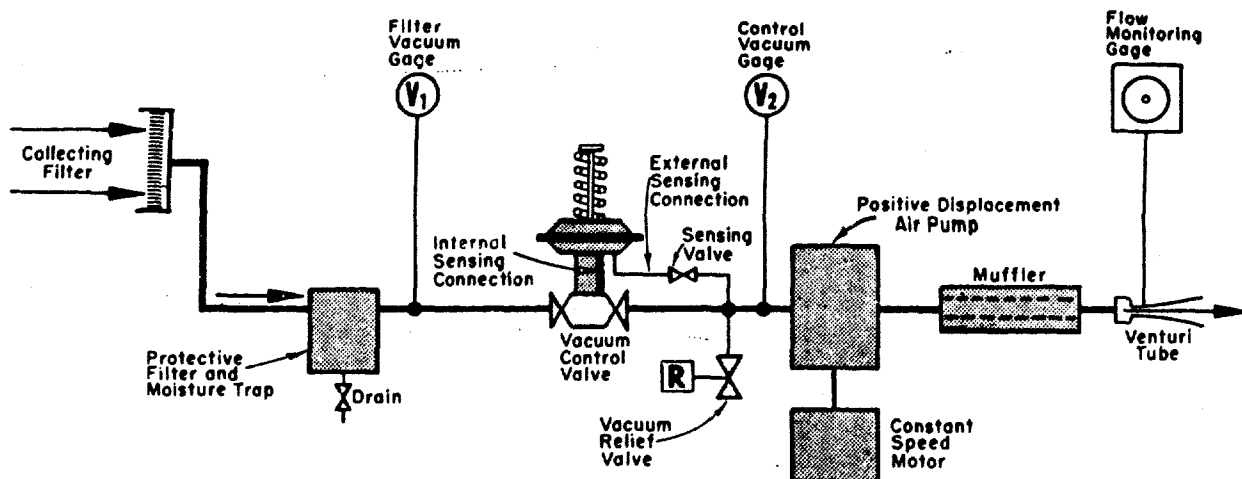

Figure E.6 Schematic diagram of arrangement of suction unit.

gage, filter vacuum gage and safety filter ahead of the pump. The recorder kept a record of flow variations by monitoring the difference in static pressure between atmosphere and a venturi in the pump exhaust.

E.2.4 Times of Instrument and Fan Operation and Instrument Field Performance. Table E.9 documents the best available information on the times of operation of power driven instruments, ventilation

TABLE E.9 OPERATIONAL TIMING FOR SHOTS 2, 4 and 5

	Instruments and Fans Started	Instruments Stopped	Ventilation Cubicle Fans Stopped	Boiler Air Shutdown
Shot 2				
YAG 39	S-3 hr	S+5 hr	S+5 hr	S+4 hr 30 min
YAG 40	S-3 hr 35 min to S-3 hr 25 min	S+4-1/2 hr	S+6 hr <sup>(a)</sup>	Not known
Shot 4				
YAG 39	Fans not started <sup>(b)</sup> Instruments started S-45 min	S+12-1/2 hr	Fans not started <sup>(b)</sup>	No shutdown - samples recovered by S+32 hr
YAG 40	S-3-1/2 hr	S+19-1/2 hr	S+20 hr <sup>(c)</sup>	S+3 hr 40 min
Shot 5				
YAG 39	S-1 hr	S+21-1/2 hr	S+26 hr	No shutdown - samples recovered by S+30 hr
YAG 40	S-3 hr 45 min	S+18 hr 45 min	S+20 hr <sup>(c)</sup>	S+8 hr 15 min

(a) Record shows a drop to 0 in. of water between static tops at shot time for Condition V, YAG 40. Either the recorder or the ventilation fans had stopped.

(b) A personal error resulted in a failure to start the fans.

(c) Time of shutdown of fans in Condition I not known but after S+20 hr.

fans and boiler air shutdown for the three shots from which data were obtained.

It may be observed in Table E.9 that the instrument operation time was increased considerably for Shots 4 and 5. This increased time required a reduction in the speed of filter-paper movement through the continuous air samplers in order that the available 270 ft of filter paper would not be exhausted during the run.

Filter-paper speeds in below-decks samplers were less than those in weatherside samplers to allow for reduction in activity levels in the below decks spaces at the expense of activity peak discrimination. Air-sampler filter-paper speeds for three shots are given in Table E.10.

Table E.11 lists the performance of continuous air samplers for three

TABLE E.10 LINEAR SPEED OF FILTER PAPER PASSING INTAKE PORTS OF THE CONTINUOUS AIR SAMPLERS

Location of Air Samples	Type	Ambient Temperature	Linear Speed of Filter Paper (in/min)	
			Shot 2	Shots 4 and 5
Cond. II - Station 1, YAG 39	short	normal	4	1
Cond. II - Station 5, YAG 39	short	normal	1/2	1/4
Cond. I - Station 1, YAG 40	short	normal	4	1
Cond. I - Station 5, YAG 40	short	normal	1/2	1/4
Cond. II - Station 1, YAG 40	short	normal	4	1
Cond. II - Station 2, YAG 40	short	normal	2	1
Cond. II - Station 3, YAG 40	short	normal	1	1/2
Cond. II - Station 4, YAG 40	short	normal	1/2	1/4
Cond. II - Station 5, YAG 40	short	normal	1/2	1/4
Cond. III - in cubicle, YAG 40	short	normal	1/2	1/4
Cond. IV - Station 5, YAG 40	short	normal	1/2	1/4
Cond. V - Station 5, YAG 40	short	normal	1/2	1/4
Cond. VI - Station 5, YAG 40	short	normal	1/2	1/4
Top of deckhouse, YAG 40	long	normal	4	1
Top of bridge - YAG 40	long	normal	4	1
Under fiddley space, fireroom, YAG 40	long	high	4	1
Ahead of blower-boiler air duct, YAG 40	long	high	4	1
In starboard windbox, YAG 40	long	high	-	-
In windbox between boilers, YAG 40	long	high	1/2	1/4
In fireroom between boilers, YAG 40	long	high	1/2	1/4
No. 2 kingpost, YAG 39	long	normal	4	1
Ahead of blower-boiler air duct, YAG 39	long	high	4	1
Between boilers, fireroom, YAG 39	long	high	1/2	1/4

shots. No difficulty was experienced with any of the suction units attached to air samplers during these three events.

Table E.12 summarizes the molecular filter particle collector operation for three shots. The top line for each particle collector and shot refers to the operation of the suction unit. The bottom line describes damage, where it occurred, to the molecular filters.

### E.3 ANALYSIS SUPPLEMENT

E.3.1 Decay Correction of a Typical Graph of Activity Versus Time. To demonstrate the nature of the airborne activity concentration during the actual test run, a typical graph obtained from the air sampler at Station 5, Condition II, YAG 40, Shot 5, has been corrected for decay point by point to the time of arrival. A comparison of this curve is shown in Figure E.7 with the same curve, all of whose ordinates are corrected to S+10 days.

TABLE E.11 CONTINUOUS AIR SAMPLER PERFORMANCE FOR 3 SHOTS

Air Sampler Location	Operation During Shot 2	Operation During Shot 4	Operation During Shot 5
Cond. II - Station 1, YAG 39	operated successfully	operated successfully	operated successfully
Cond. II - Station 5, YAG 39	operated successfully	operated successfully	operated successfully
Cond. I - Station 1, YAG 40	operated successfully	operated successfully	operated successfully
Cond. I - Station 5, YAG 40	operated successfully	operated successfully	operated successfully
Cond II - Station 1, YAG 40	pin broke in drive roller, record lost	operated successfully	operated successfully
Cond. II - Station 2, YAG 40	operated successfully	operated successfully	ran out of filter paper near end of run
Cond. II - Station 3, YAG 40	operated successfully	operated successfully	ran out of filter paper near end of run
Cond. II - Station 4, YAG 40	operated successfully	operated successfully	operated successfully
Cond. II - Station 5, YAG 40	operated successfully	operated successfully	operated successfully
Cond. III - in cubicle, YAG 40	operated successfully	operated successfully	operated successfully
Cond. IV - Station 5, YAG 40	operated successfully	operated successfully	operated successfully
Cond. V - Station 5, YAG 40	operated successfully	operated successfully	operated successfully
Cond. VI - Station 5, YAG 40	operated successfully	operated successfully	operated successfully
Top of deckhouse, YAG 40	operated successfully	stopped intermittently part of record satisfactory	stopped intermittently part of record satisfactory
Top of bridge, YAG 40	filter paper wound erratically on take-up reel	filter paper tore after a brief run	filter paper tore - stationary sample lost
Top of stack, starboard side of YAG 40	failed during Shot 1	Discontinued for succeeding shots	
Top of stack, port side of YAG 40	failed during Shot 1	Discontinued for succeeding shots	
Under fiddley space, fireroom YAG 40	operated successfully	ran out of covering strip; filter ran successfully; sample lost in analysis	discontinued
Ahead of blower, boiler-air duct, YAG 40	operated successfully	operated successfully	discontinued
In starboard windbox, YAG 40		destroyed by salt water corrosion following Shot 2	
In windbox between boilers, YAG 40	filter paper tore, stationary sample returned to NRDL	record lost	

TABLE E.12 MOLECULAR FILTER PARTICLE COLLECTOR PERFORMANCE FOR 3 SHOTS

Particle Collector Number	Shot 2 Operation	Shot 4 Operation	Shot 5 Operation
1 suction unit particle collector	Operated successfully samples complete	Operated successfully samples complete	Filters loaded, flow dropped samples complete
2 suction unit particle collector	Operated successfully samples complete	Operated successfully samples complete	Filters loaded, flow dropped samples complete
3 suction unit particle collector	Operated successfully samples complete	Operated successfully samples complete	Operated successfully samples complete
4 suction unit particle collector	Operated successfully one sample complete	Stopped during run one sample complete	Operated successfully one sample complete
5 suction unit particle collector	Operated successfully samples complete	Operated successfully samples complete	Filters loaded, flow dropped samples complete
6 suction unit particle collector	Operated successfully samples complete	Operated successfully samples complete	Operated successfully samples complete
7 suction unit particle collector	Operated successfully samples complete	Operated successfully sample 72 destroyed	Operated successfully both samples torn
8 suction unit particle collector	Operated successfully samples complete	Operated successfully sample 81 destroyed sample 82 complete	Operated successfully both samples destroyed
9 suction unit particle collector	Filter loaded-flow dropped samples complete	Filter loaded, flow dropped samples complete	Filter loaded, flow dropped samples complete
10 suction unit particle collector	Operated successfully samples complete	Operated successfully samples complete	Operated successfully both samples torn
11 suction unit particle collector	Filter loaded, flow dropped samples complete	Filter loaded, flow dropped samples complete	Filter loaded, flow dropped samples complete
12 suction unit particle collector	Operated successfully samples complete	Operation intermittent samples complete	Operated successfully samples complete



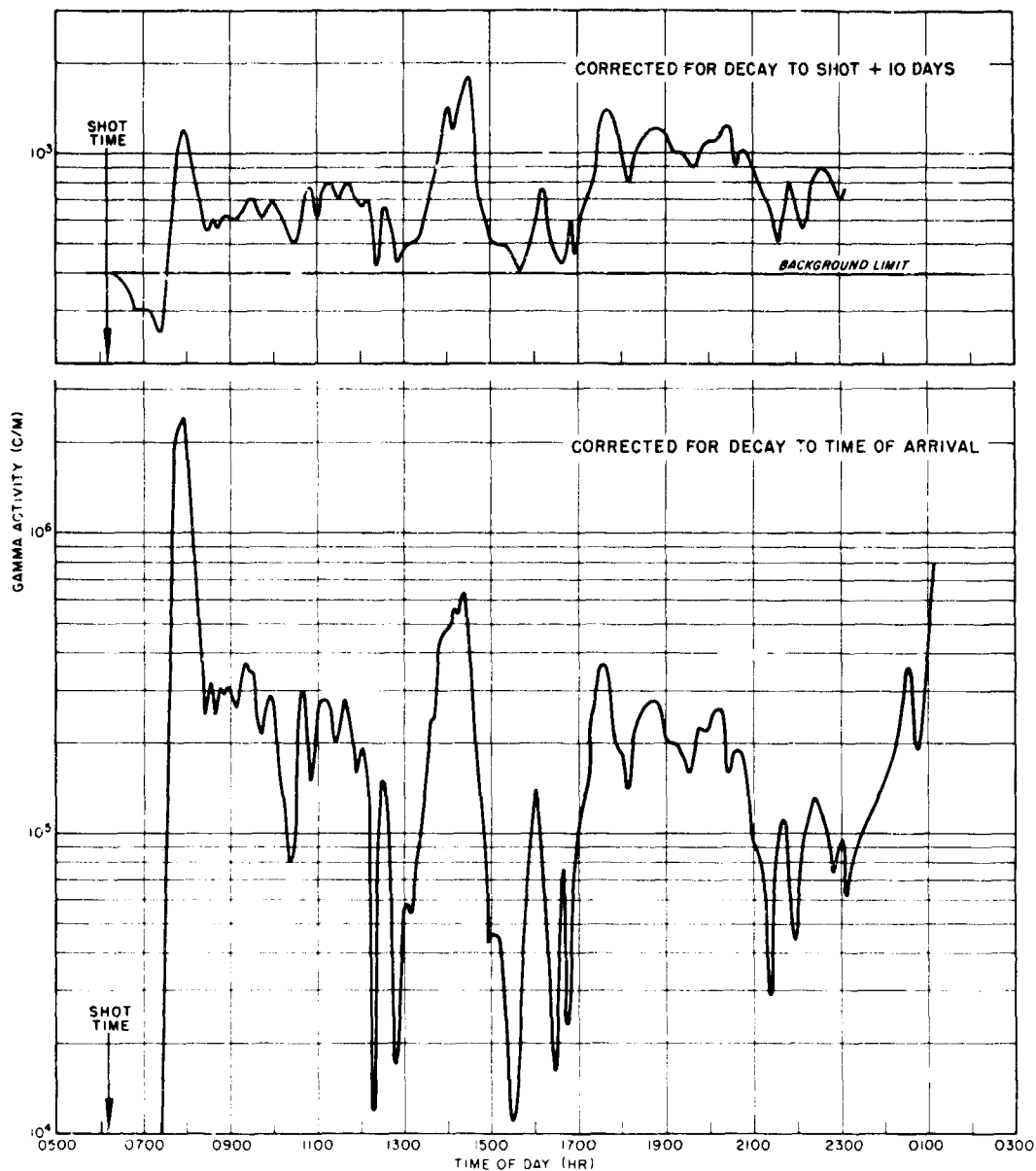

Figure E.7 Comparison of curves of activity versus time for Condition II, Station 5, Shot 5 corrected to time of activity arrival and corrected to S+10 days.

E.3.2 Activity Ratios Between High- and Low-Flow Heads. It is notable that the ratios between the counting rates of the high-speed collecting heads and the low-speed heads are not the same as the flow ratios between those heads (Table E.13).

Small differences are seen to exist between the measured flow ratios and the intended ratio of 30 to 1; however, very large differences occur among the ratios obtained from the count rates of the molecular filters. Particle Collector 3 sampling from the most undisturbed air shows the best consistent ratios whereas Particle Collector 6, sampling from a much smaller particle population, and Particle Collectors 9 and 11, whose flow rates rapidly dropped because of soot-choked filters, produce the smallest ratios. Figures E.8 and E.9 indicate a drop in flow of collectors 1, 2, and 5 for Shot 5. This circumstance reflects in Table E.13.

TABLE E.13 COUNT RATE AND AIR FLOW RATIOS BETWEEN HIGH-FLOW AND LOW-FLOW PARTICLE COLLECTOR HEADS

Particle Collector Number	Shot 2		Shot 4		Shot 5		Measured Flow Ratios
	$\beta$ Count Ratio Between High and Low Speed Collecting Head	$\gamma$ Count Ratio Between High and Low Speed Collecting Head	$\beta$ Count Ratio Between High and Low Speed Collecting Head	$\gamma$ Count Ratio Between High and Low Speed Collecting Head	$\beta$ Count Ratio Between High and Low Speed Collecting Head	$\gamma$ Count Ratio Between High and Low Speed Collecting Head	
1	-	18.3:1	9.5:1	17.8:1	0.83:1	1.4:1	28.6:1
2	-	9.3:1	8.8:1	21.8:1	18.2:1	5.8:1	27.1:1
3	-	20.7:1	15.3:1	34.3:1	17.7:1	20.0:1	26.9:1
5	-	13.2:1	35.2:1	20.8:1	17.8:1	12.5:1	29.9:1
6	-	0.38:1	10.7:1	34.4:1	5.0:1	2.7:1	30.5:1
9	-	1.3:1	1.6:1	0.97:1	1.1:1	1.7:1	27.1:1
11	-	3.1:1	2.0:1	1.2:1	14.8:1	16.8:1	-
12	-	11.5:1	12.9:1	22.1:1	28.8:1	14.6:1	30.9:1

**E.3.3 Estimate of Suction Unit Flow Rates.** In practice, the suction units varied from the ideal of a 10-cfm continuous flow rate. Some of the motors overheated from undetermined causes and were cut out by the thermal protection switch. Filters clogged with soot causing excessive pressure drops, especially in the boiler systems, which resulted in reduced flow rates, and in general, the actual flow rate would drift away from 10 cfm

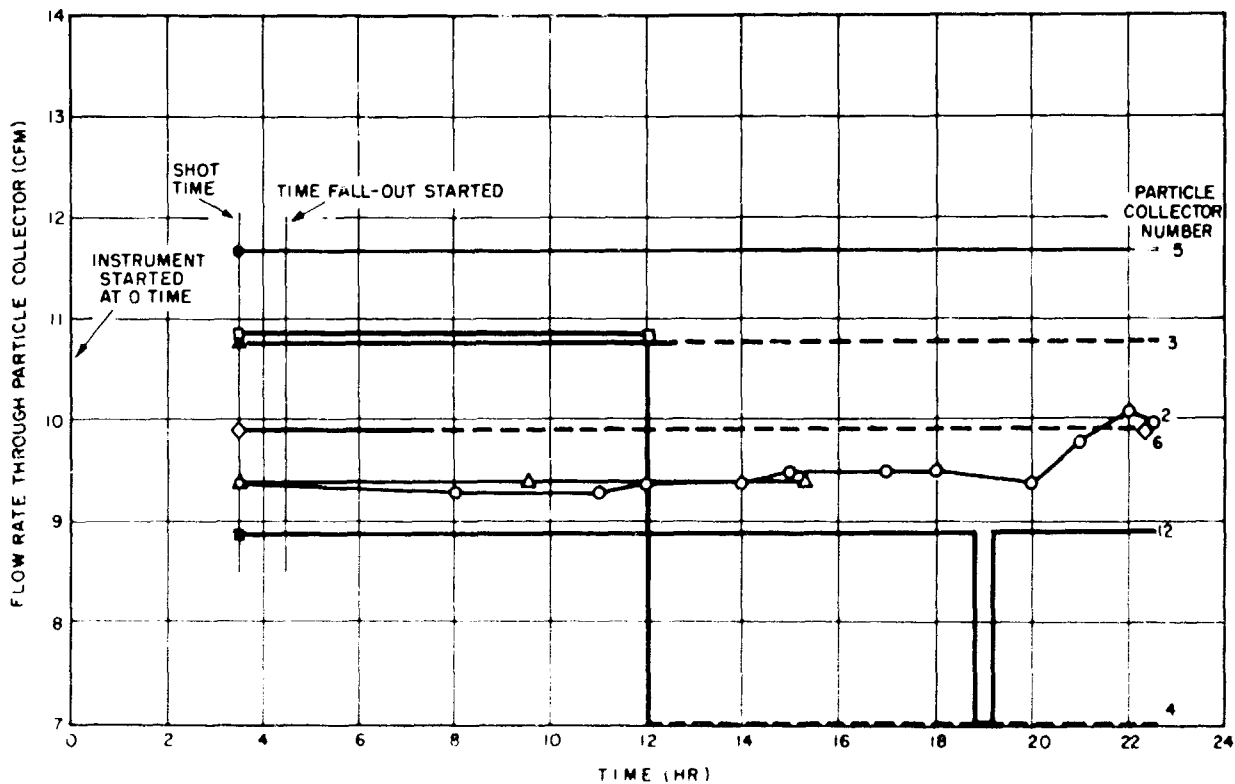

Figure E.8 Particle collector suction unit flow rates versus time, Shot 4

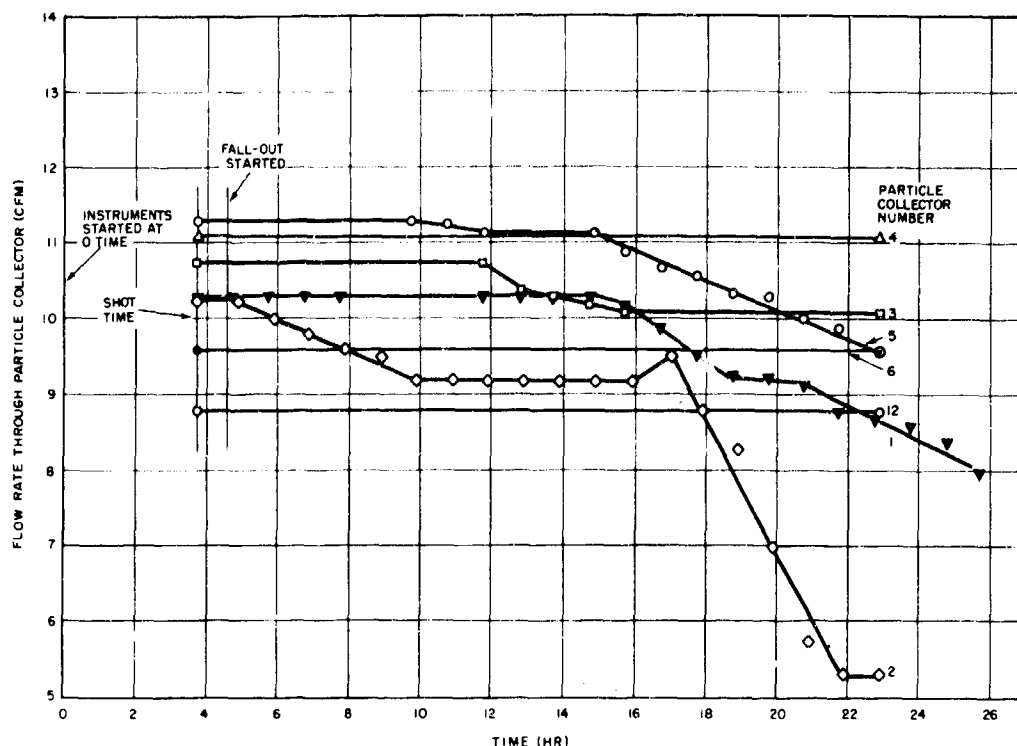

Figure E.9 Particle collector suction unit flow rates versus time, Shot 5

over periods of days or weeks. On the basis of the recorder charts taken from each suction unit, it has been possible to plot the estimated flow rate of each unit against time. The plotted points (Figures E.8 and E.9) begin at the time fallout was first encountered and end at the time the pumps shut off since no cessation of airborne activity is evident on the continuous air-sampler graphs. In averaging some of the sharp variations in the curves, the total volume of air through each particle collector was obtained and is given in Table E.14.

For Shots 4 and 5 the flow rates through Collectors 9 and 11 were

TABLE E.14 TOTAL VOLUME OF AIR SAMPLED BY PARTICLE COLLECTORS

	Volume of Air Sampled (cu ft)		
	Shot 2	Shot 4	Shot 5
1	-	6090	12430
2	609	10270	9530
3	788	11680	11460
4	781	4950	12190
5	816	12710	11880
6	670	10630	10540
9	350 <sup>(a)</sup>	-	-
11	574 <sup>(a)</sup>	-	-
12	728	9450	9660
Air sampler between boilers, YAG 39	-	-	8960
Air sampler between boilers, YAG 40	-	-	6250
DME filter on bridge, YAG 40	-	10100	9880

(a) Flow measurement difficulties made the accuracy of these values especially unreliable.

negligible. However, for Shot 5, stationary filters from the air samplers at equivalent locations as Collectors 9 and 11 are substituted (Figure E.10).

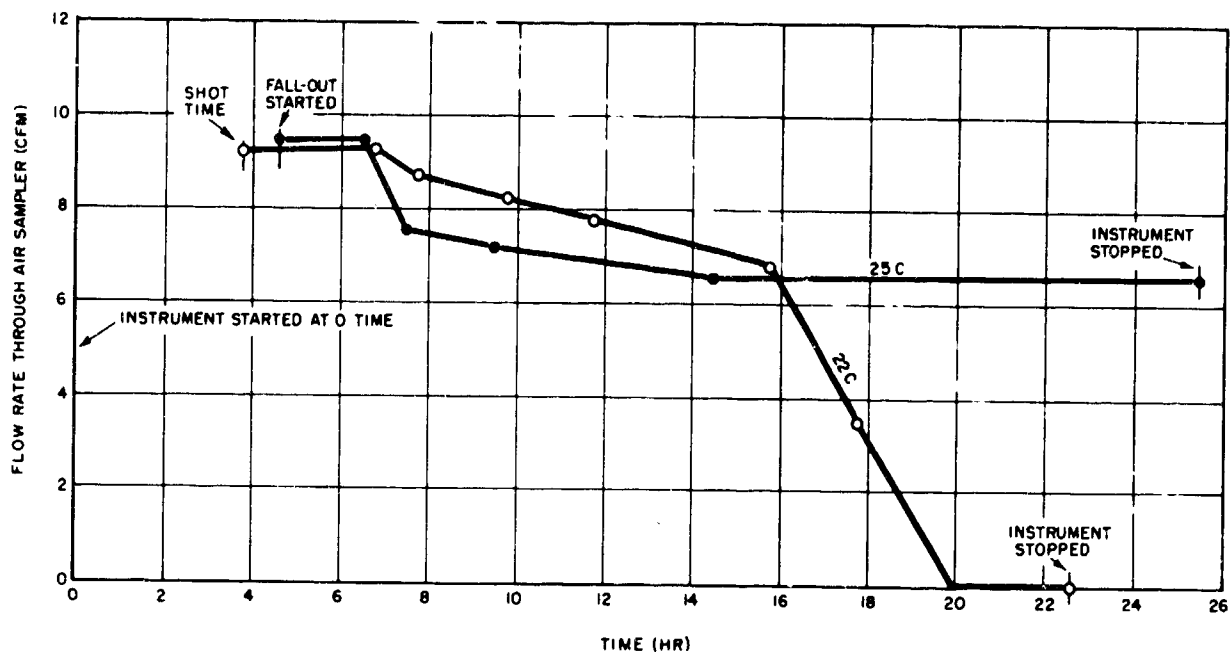

Figure E.10 Flow rate versus time for fire room air sampler suction units, Shot 5

E.3.4 Estimate of Beta Disintegration Rate and Calibration of Ionization Chamber. Absorption curves were made of four standards ( $C^{14}$ ,  $Co^{60}$ ,  $Tl^{204}$ ,  $Pa^{234}$ ) manufactured by the Atomic Instrument Company. These standards were each inscribed with an effective disintegration rate referred to a specific date of count. Accuracy was listed as  $\pm 10$  percent. Since the standards were covered with varying thicknesses of aluminum absorbers to stop undesirable beta components and to protect the activity deposits from damage, the disintegration rates listed were not those of the samples but, rather, the apparent activities of the samples after correction had been made for geometry losses. That is, the apparent disintegration rate of each sample would be that of an uncovered sample whose activity was less by an amount equivalent to the reduction of beta activity of the standard in passing through the cover foil. Allowance was made for the cover thickness and tube-window thickness (1.8 mg/sq cm) on the aluminum absorption curves (Figure E.11) of these standards. These curves were normalized to a maximum activity of 1.0 by dividing the counts at each absorber thickness by the count rate at minimum absorber thickness.

Figure E.12 consists of aluminum absorption curves of four different samples taken from Shots 4 and 5. All but the sample of copper liner from the top of the deckhouse, Shot 5, are molecular filter samples. It may be noted that, except for the copper liners, all the curves are similar in shape. Identical mountings were used for the test samples as were supplied with the standard. The constant-slope section of the molecular-filter absorption curves (between 200 and 800 mg/sq cm) represent a maximum beta energy greater than 2.32 Mev (the maximum beta energy of  $Pa^{234}$ ) or a very-low-energy gamma component. For the purposes of this discussion, it will be identified as a high-energy beta component.

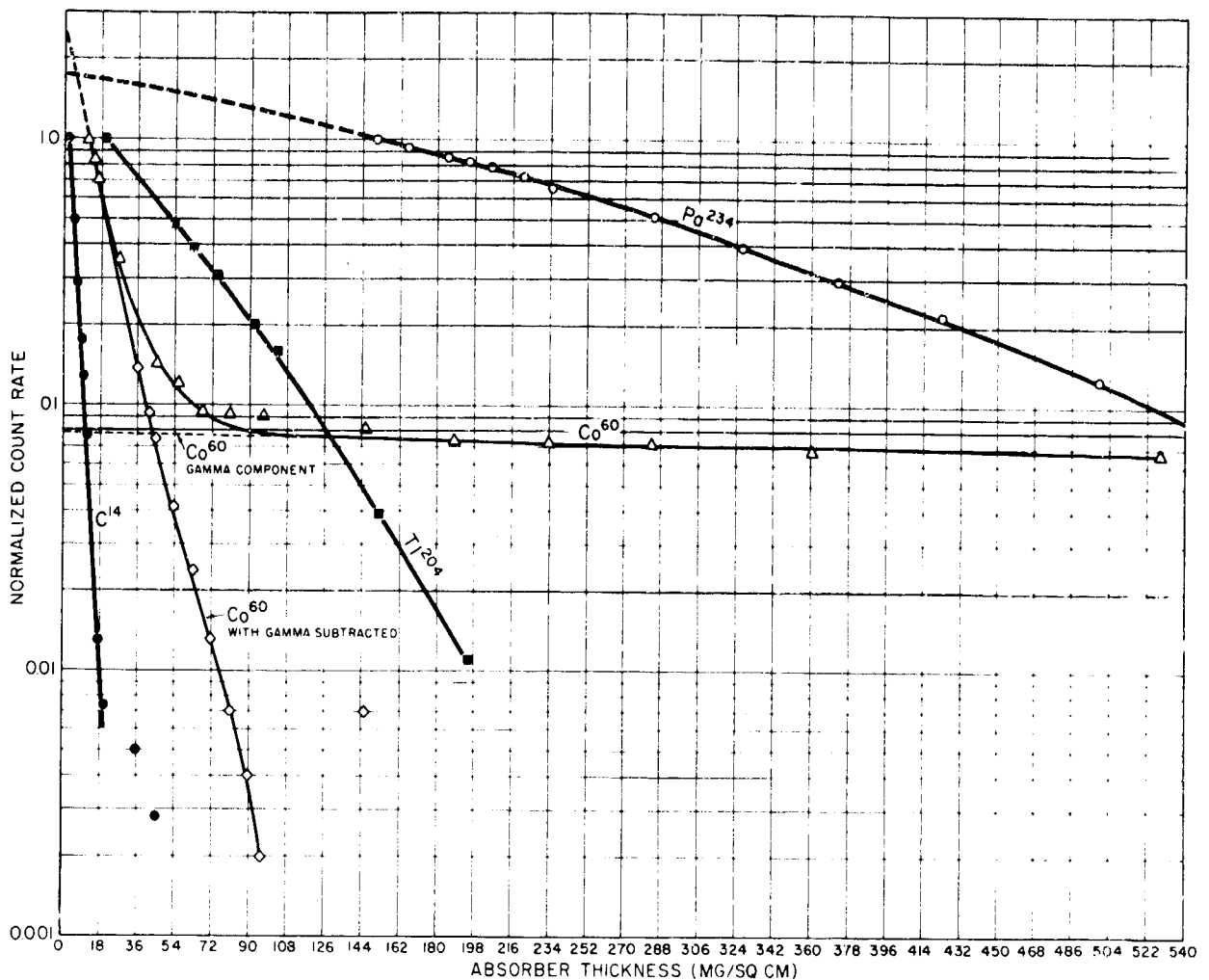

Figure E.11 Absorption curves of isotope standards

Figure E.13 reproduces a superposition of the absorption curves of samples 72-5 and 101-4 with the identifiable gamma components subtracted out. Here again, the curves have been normalized to a maximum count rate of 1.0. Hereafter, the contribution of the gamma activity to the unabsorbed count rate of the test samples will be ignored, inasmuch as it amounts to less than 1 percent of the total count.

Isotopes with maximum beta energies greater than about 1.2 Mev have been found to cause similar response in a GM tube. Because of this circumstance, it is possible to consider the high-energy beta component of the molecular filter samples to be equivalent to Pa<sup>234</sup>. This component has been labelled Component X and is subtracted in Figure E.13 from the total-absorption curve. The initial slope of the resultant closely resembles that of the beta contribution to the Co<sup>60</sup> absorption curve. The latter cannot be subtracted to produce still a third, low-energy beta component. The poor resolution of this procedure is evident in that beta energies much lower than 0.31 Mev (maximum energy of Co<sup>60</sup>) are known to exist in fission products. As a result of the uncertainty, disintegration rates for the test samples derived from this study must be considered, at best, lower limits of the actual disintegration rates.

Considering, hypothetically, that the samples consist of two isotopes,

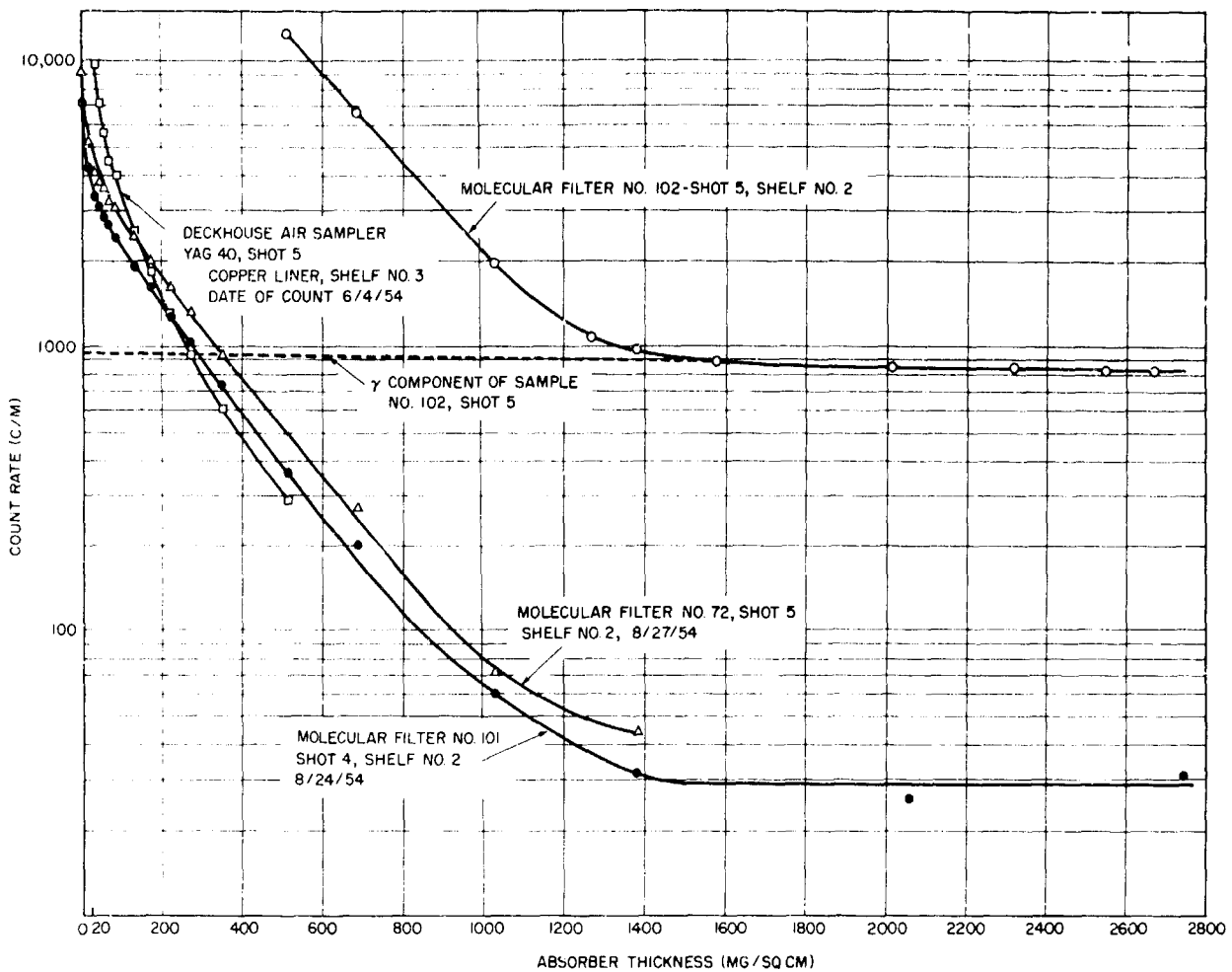

Figure E.12 Absorption curves of cone liner and molecular filter samples.

$\text{Co}^{60}$  and  $\text{Pa}^{234}$ , it may be seen from the curves in Figure E.13 that  $\text{Co}^{60}$  contributes 54 percent of the observed count rate and  $\text{Pa}^{234}$  supplies 46 percent.

On 31 August 1954, the  $\text{Co}^{60}$  standard produced 3,980 c/m in the GM tube (Shelf 2). On the same date,  $\text{Pa}^{234}$  counted at the rate of 2,340 c/m. The effective disintegration rate of  $\text{Pa}^{234}$  as of 31 August was  $1.02 \times 10^4$  d/m. The total geometry for an isotope of energy equal to or greater than  $\text{Pa}^{234}$  must be  $2.34 \times 10^3 / 1.02 \times 10^4 = 23$  percent.

The situation for  $\text{Co}^{60}$  is more complex as a result of the significant gamma component. Extrapolating the total absorption curve of  $\text{Co}^{60}$  back to the points of 0 absorber, it may be seen that for a total ( $\beta + \gamma$ ) count of 2,500, 78 c/m are gamma;  $2,500 - 78 = 2,422$  c/m of beta alone. Since there are two gamma's and one beta emitted upon each disintegration, the tube has twice the chance of perceiving a gamma event as it has of perceiving a beta event. Therefore, the response of the GM tube to gamma radiation is  $78/2 \times 2,422 \times 100$  percent = 1.6 percent. Correcting the 31 August count for beta absorption:  $3,980 \times 2.5$  percent<sup>1</sup> = 9,550 c/m total beta and gamma radiation. Let X = beta count with no absorber

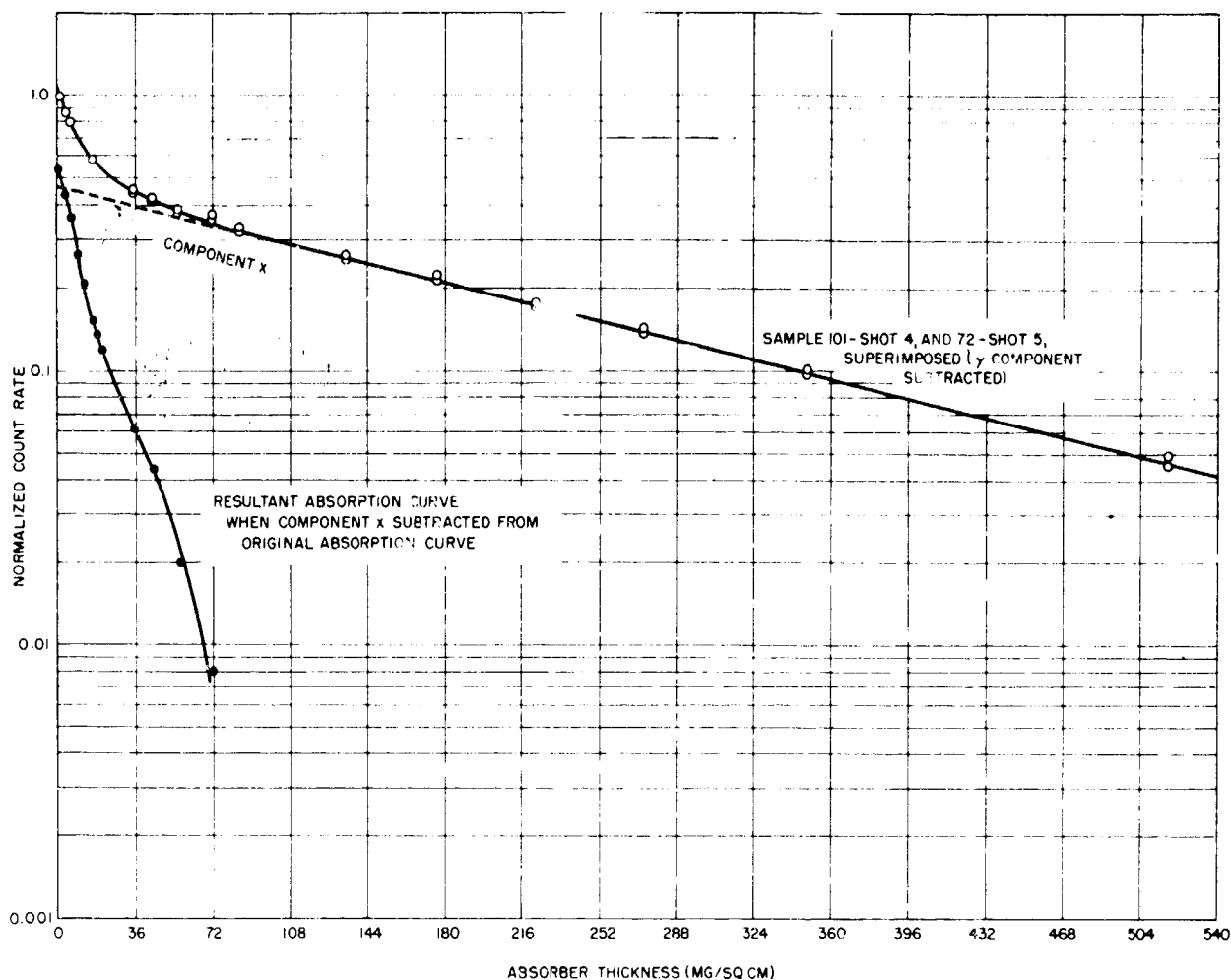

Figure E.13 Determination of apparent beta components for comparison of sample and standard absorption curves.

$$X + 2X \cdot 0.016 = 9550 = 1.032X$$

$$X = 9640 \text{ c/m}$$

Whereupon  $9550 \text{ c/m} - 9640 \text{ c/m} = 310 \text{ c/m}$  of gamma, assuming the gamma count to be unchanged upon the addition of  $12.7 \text{ mg/sq cm}$  of absorber. The beta count rate as of 31 August =  $3,670 \text{ c/m}$ .  $\frac{3.67 \times 10^3}{3.73 \times 10^4} = 9.8$  percent geometry of

tube for  $\text{Co}^{60}$  beta radiation. Where the effective disintegration rate of each sample where Z is the observed counting rate:

$$0.23 \times (0.46Y) + 0.098 \times (0.54Y) = Z$$

producing  $Y = 6.3Z$ .

The calibration of the  $4\pi$  ionization chamber against the gamma scintillation counter was done by counting molecular filters in both. Molecular filters of various radioactive ages were counted on the floor of the scintillation counter. The same filters were then counted in the ionization chamber yielding activity in terms of millivolts. A plot of millivolts against counts/sec is given in Figure E.14, where a straight line has

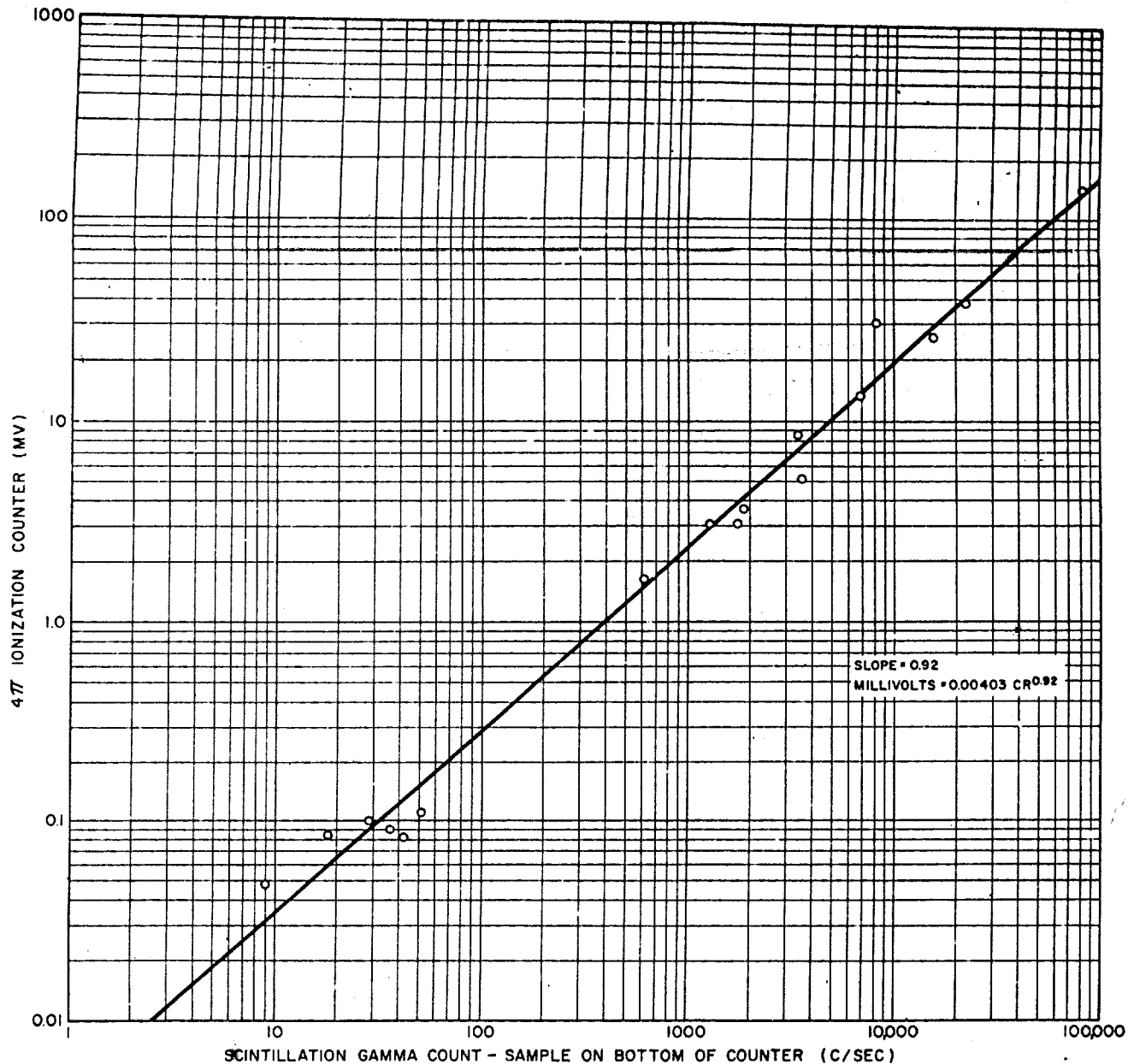

Figure E.14 Calibration curve of ionization and scintillation counters

been drawn by eye through the experimental points. Extrapolations were performed where necessary to express cone liner, adhesive-coated paper and DMT filter data in terms of counts per minute.

**E.3.5 Analysis of Weatherside Cone Liner, Shot 5.** A cone liner taken from the air sampler mounted on the deckhouse of YAG 40 was divided into small pieces for counting with the Geiger tube. A plot of the average beta activity per square centimeter against distance from the cone intake is shown for this copper liner, exposed in Shot 5, Figure E.15.

<sup>1</sup> The factor of 2.5 is derived by taking the ratio of the total  $\beta + \gamma$  count at 0 absorber thickness to the  $\beta + \gamma$  count at an absorber thickness of 12.7 mg/sq cm (see Figure E.11).



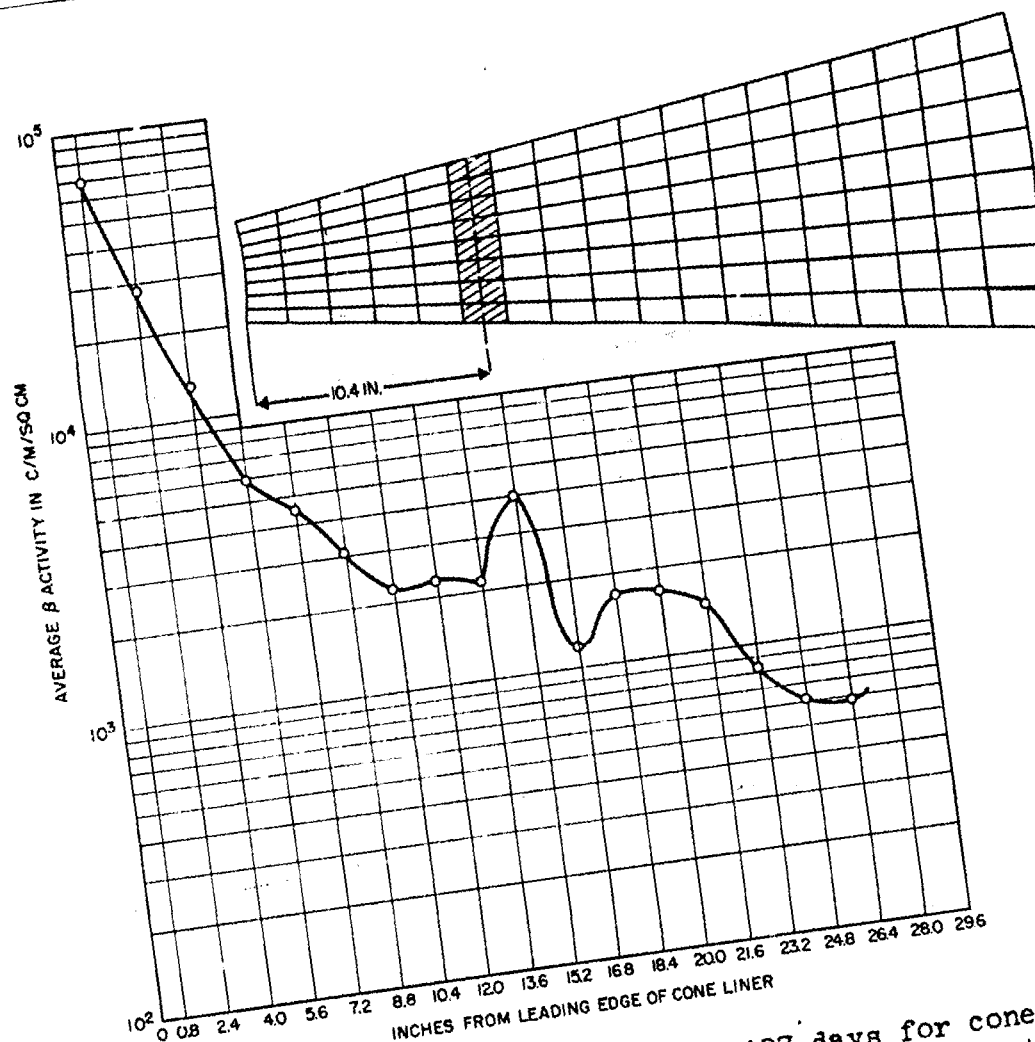

Figure E.15 Activity corrected to S+27 days for cone liner taken from deck house air sampler on YAG 40 at Shot 5.

The foil was cut into 144 separate pieces for beta counting. Each point on the curve represents the average count per minute per square centimeter of eight pieces of foil which lay roughly on a radial line inside the cone at the distance specified from the entrance. A reproduction of the cone liner is shown in the insert. The eight shaded segments comprised the samples counted to obtain the average area count at 10.4 in. from the leading edge of the liner.

## Appendix F

# DESIGN AND DEVELOPMENT CONSIDERATIONS OF INSTRUMENTATION

### F.1 FIXED GAMMA RECORDER

The gamma measuring and recording system had to supply information about the dose and dose rate at a large number of points aboard two ships. Originally it was planned to use conventional logarithmic responding instruments to indicate the dose rate; however, such instruments have a rather large inherent error. Assuming a 1-percent instrument reading error and a 5-decade response, the inherent error due to the logarithmic response is  $\pm 26$  and  $-20$  percent, which is too large. Another factor against these instruments was the fact that records of dose as a function of time were the primary requisites of the field operation.

A different approach was made to the problem. The instrument employed was a recycling integrating ion chamber by which each increment of dose was recorded. The record of dose versus time was the running total of the dose increments. The dose rate was the slope of the dose curve or could be computed by measuring the time required to accumulate the dose increment. Such a system is capable of  $\pm 5$  percent accuracy, at least. Because the dose rates were expected to range from background to 10,000 r/hr, each instrument station should consist of a group of detectors. Thus, to detect background rates a detector would have to recycle at 0.1 mr; in fields of 10,000 r/hr it would have to recycle  $10^8$  times per hr. Such a requirement is impractical. Also, the ion chamber would have to be rather large to detect the 0.1-mr increments and a very-high voltage would be needed to collect in the 10,000-r/hr field. The number of detectors required at each station was finally settled by the choice of the recorder.

Several types of recorders were considered; some were discarded because of their complexity and others because of their cost. Since 137 stations were to be equipped with groups of detectors, a large number of channels of inexpensive recording was required. Magnetic tape recorders were considered but discarded because of their cost and the additional maintenance they required. Pen-and-ink recording was chosen, as it was the simplest, most reliable, and most economical. Pulse-type recording to indicate when the increment had been accumulated was adequate, because it was not necessary to designate levels or relative amplitudes. The function recorder<sup>1</sup> normally employed to indicate when circuits are energized or de-energized was selected for use with the gamma detectors. This recorder contains 20 individual pens actuated by solenoids that displace the pens approximately  $3/8$  in; it records 20 channels of information.

The recorders held a 100-ft roll of tape driven by a mechanical 8-day

---

<sup>1</sup> Mfg. by Raytheon Manufacturing Co., Newton, Mass.

clock. Since unattended operation for periods of 100 hr was required, the tape was run at 1 ft/hr. If pulses were spaced at 40 per in., individual pulses were barely discernible. This spacing would correspond to a chamber recycling 480 times per hr or 1 increment every 7.5 sec. To provide a safety factor, a maximum pulse spacing of 30 per in. (1 every 10 sec) was selected.

Conversion of pulse spacing to dose and dose-rate curves would be difficult unless each chamber covered a whole number of decades. If each chamber covered 2 decades, the maximum time between increments was 1,000 sec; if it covered 3 decades, the pulse spacing was 10,000 sec, which would yield poor time resolution. With each chamber covering 2 decades, four chambers per station were required. The most sensitive chamber, A, was sized for an increment of 0.1 mr; B for an increment of 10 mr; C for an increment of 1 r, and D for an increment of 100 r. Since any chamber could be used at recycling rates as great as 360 per hr, fields of 36,000 r/hr could be handled by the D chamber.

The recycling integrating ion chamber instrument consisted of four basic elements; the ion chamber, an electrometer vacuum tube, a power amplifier and a relay. Several different designs of ion chamber were considered. A parallel-plate chamber was designed, but its energy response was inadequate, and the chamber was difficult to fabricate. A concentric cylinder design was used, but the A ion chamber presented some difficulty. The charge produced by a dose of 0.1 mr in a volume of 1 liter is  $0.922 \times 10^{-13}$  coulombs. If the chamber capacity and integrating capacity are each a reasonable size, the chamber volume would be too large to be practical. Even stray wiring capacity was too great to be discharged by a 1.2-liter chamber that operated at atmospheric pressure. Consequently, the A chamber was operated at 10 atmospheres. The B chamber was operated at only 2 atmospheres and with an integrating capacitor of 100 puf. The C chamber was operated at 2 atmospheres and with an integrating capacitor of 0.01  $\mu$ f. The volume of each of these chambers was 1.2 liters. The D chamber was not the same volume, because the collection voltage would be impractical. Instead of using the 1.2 liter chamber and increasing the integrating capacitor by a factor of 100, the volume was reduced by this same factor; a 0.01 uf integrating capacitor was used, and the D chamber was operated at 2 atmospheres.

Energy response was important, because the gamma field to be measured was due to mixed fission products. The A, B, and C chambers had excellent energy-response curves. The curve for the D chamber had a large peak at low energies, and filtering was necessary to improve the response. A 6-mil lead foil which was wrapped and crimped around the aluminum chamber was a satisfactory filter. The response was within 15 percent of being linear from 100 kev to 2 Mev.

The chambers were filled with nitrogen. To facilitate testing of the pressurized chambers, 2 percent of helium was added, and a helium-leak detector was used to test the chamber seals. A group of the chambers were placed in a vacuum chamber, and any leakage from them was drawn out by the vacuum pump through the helium-leak detector. Unfortunately, some of the chambers developed leaks after they had been in use. This difficulty was probably caused by vibrations and shock to which the chambers were subjected during calibration and installation aboard the ship.

Considerable difficulty was encountered in obtaining satisfactory

integrating capacitors. These capacitors had to have a self-time constant in excess of 10 hr, which means a leakage resistance of  $3.6 \times 10^{14}$  ohms for the 0.01  $\mu\text{f}$  capacitor. The leakage resistance must be maintained at temperatures up to 120°F. The capacitance must be stable, and the capacitors must not polarize. Some of the capacitors tested exhibited a capacitance change if voltage was applied for several hours. This condition could not be tolerated. The capacitors used were the Stabelex D.<sup>1</sup> The leakage resistance was measured by a vibrating-reed electrometer to measure the voltage drop across a high-megohm resistor caused by the capacitor leakage current. The only difficulty encountered with the capacitors was caused by gamma radiation. In high gamma fields, the leakage resistance decreased to such a point that the capacitors could not be used without shielding them. A half inch of lead provided sufficient shielding to maintain the required capacitor leakage resistance.

The decision to operate the electrometer tube as an inverted triode was based on a number of considerations: Since a large swing voltage was to be used to increase the accuracy of the system, it was felt that the grid current would be excessive if the first grid G was operated at large negative voltages. Also, considerable work had been done at RDL on inverted triode electrometer circuits. Tests were conducted on several types of electrometer tubes and type 5800<sup>1</sup> was chosen based on the results and past experience.

Since battery operation was desirable, an attempt was made to use a transistor as the power amplifier required, because the output current from the inverted triode was not sufficient to drive a relay directly. Considerable effort was devoted to the transistor circuit. From tests it was decided that a NPN transistor used in a grounded emitter circuit would be the best. As design and testing progressed, it became evident that such a circuit would not be stable enough. The transistors available were not hermetically sealed so were subject to failure due to moisture absorption. Also the transistor characteristics varied over wide limits with moderate temperature changes.

A brief attempt was made to use a vacuum tube or gas tube power amplifier circuit. Although such circuits can be made to operate satisfactorily, considerable more power is required than when a transistor is used and since the circuit is more complex, frequent failures are to be expected. The circuit finally selected used a Sensitrol relay<sup>2</sup> which is a meter type movement with magnetic lock-in features. This relay can be reset electrically by energizing a solenoid and can be obtained with a 5- $\mu$  amp sensitivity.

A 5- $\mu$  amp Sensitrol was used but it was biased so that 25 to 50  $\mu$  amp were required to energize it. The input-voltage versus output-current characteristics of the inverted triode are shown in Figure F.1. The characteristic curve is much steeper at 50  $\mu$  amp than at 5  $\mu$  amp, consequently the 50  $\mu$  amp firing point will permit less error in determining the voltage point at which the ion chamber and integrating capacitor discharge. The bias current for the Sensitrol was obtained from a dry cell and was set with a potentiometer.

The power amplifier energizes the recycling relay which must recharge the ion chamber and integrating capacitor and energize the recorder. It

<sup>1</sup> Mfg. by Raytheon Manufacturing Co., Newton, Mass.

<sup>2</sup> Mfg. by Western Electrical Instrument Corp., Newark, N.J.

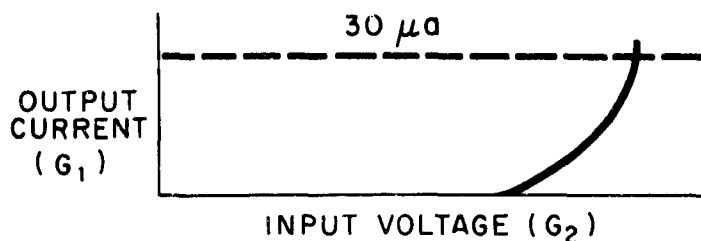

Figure F.1 Characteristic curve of the inverted triode.

also recharges the delay circuitry. The ion chamber circuit must have a minimum resistance of  $10^{13}$  ohms to ground. Because relays are not available with insulation of this magnitude, a special relay<sup>1</sup> was required. The relay contact which recharges the ion chamber circuit was a special coiled spring which was gold washed to decrease contact corrosion as very little contact pressure was available. This spring made contact with the supporting stud which contacted the chamber collecting electrode.

The delay circuitry limited the maximum recycle rate of the system. If an A chamber is allowed to run at its maximum rate, the recorder will draw many pulses on the same part of the tape. The excess ink is likely to splatter and weakens the paper tape. The RC network applies a voltage to the electrometer tube which prohibits current from flowing to the output circuit regardless of the input voltage on  $G_2$ . The RC time constant is such that output current cannot flow for approximately 7 sec. At this pulse rate, individual pulses are just discernible on the tape.

## F.2 DATA REDUCTION APPARATUS (DRA)

When the decision was made to use dose-increment instruments instead of logarithmic indicating dose rate ones, it was also decided to provide some mechanical means of reducing the data since a time record of dose increments from four chambers is difficult to interpret. Although the total dose as a function of time was primarily important, the dose rate as a function of time was also of interest. A data reduction apparatus (DRA) was planned to provide a plot of total dose and dose rate as a function of time.

The total dose at any time is simply the weighted running total of the dose increment pulses. The average dose rate over any dose-increment period is the value of the dose increment divided by the time needed to collect the dose increment. Obtaining the plot of total dose as a function of time was relatively simple. A cascade decade register with parallel input provided the necessary totalizer. The parallel input provided the requisite weighting. Pulses representing A chamber increments were fed into the first decade; pulses representing B chamber increments were fed into the third decade. The decades used were stepping relays<sup>2</sup>, because of experience with these units. Relays were chosen in preference to electronic decades for several reasons. First, this type of relay has been tested for 200 million operations between adjustments. They were developed for telephone

<sup>1</sup> Mfg. by Poller-Brumfield Mfg. Co., Princeton, Indiana.

<sup>2</sup> Mfg. by Automatic Electric Co., Chicago, Illinois.

service where design life is greater than 20 yr. Consequently, the reliability of these electromechanical decades is better than for vacuum tubes. Second, the DRA is not a high-speed machine. There is a practical limit to tape speed. As designed, the original tapes are run through the DRA at 100 times the original recording speed. The maximum pulse density is 10 pulses/sec. The stepping relays will operate at 35 steps/sec, so the greater possible speed of vacuum tube decades is not required. Third, the power consumption of the mechanical decades is less than with vacuum tube decades. In 5 months of operations there have been no relay failures.

The total dose is read out on an analog curve plotter connected to the readout matrix as a self-balancing bridge. In this way, changes in supply voltage do not effect the accuracy of the plotted point. The curve plotter does not draw a smooth curve but, rather, a histogram. When any dose increment is received, the curve plotter indicates the new value of total dose. As the curve plotter type is moving continuously, any indicated value of total dose is maintained until another dose increment is received.

The curve plotter has a 10-in. span. Because accuracy would have been sacrificed if the full span was to represent the available 10 decades, it was decided that each decade would cover the full span. At the end of each decade, the pen would return to the low end and begin the next decade. Side-pen markers drew pips to indicate which decade any portion of the curve represented. As any chamber could be used up to a maximum rate of 360 increments per hr, the A chamber was useable to 36 mr/hr, B chamber to 3.6 r/hr, C chamber to 360 r/hr, and D chamber to 36,000 r/hr. Consequently, full scale on the chart was designated as 40 mr or 400 units of A chamber increments. At 36 mr or 360 increments, the curve plotter pen was depressed to 3.6, and the next decade started. Each decade was represented by a full-scale span, as it was difficult to predict how small a difference between detector stations would be of interest or would be recorded.

A logarithmic plot of total dose was also provided. This plot would cover any five preselected consecutive decades. The 5-decade presentation covered the full chart.

The dose-rate unit computed the dose rate from the time between dose increments. At first it was planned to use conventional analog computer techniques to perform the computation.

$$\text{Average Dose Rate over Time } T = \frac{\text{Dose Increment}}{T}$$

T = Time to collect Dose Increment.

However, it soon became apparent that considerable mechanical design would be involved. The above computation would have to be performed many times. An involved clutch system would be required to return the computer to the initial conditions after every computation, or two computers would be required with each computer performing every other computation. Either of the two conditions would have to be met as a pulse signifying the end of one computation period also denoted the start of the next. A different method was decided upon. As the dose increments are constant while any one chamber is used and differ by integral decades between chambers, the

average dose rate over a period is inversely proportional to the time between pulses on the recorder traces. If a count of a fixed frequency is started by one pulse and stopped by the next pulse, the count registered in the counter is inversely proportional to the dose rate. If the counting is done by a binary chain and each binary switches into a relay matrix a resistor weighted by the position of that binary in the chain, then the value of the matrix can be made inversely proportional to rate. If the reciprocal action is used, i.e., each binary switches in a conductance, then the voltage drop across a fixed resistor in series with the conductance matrix will be proportional to dose rate.

The recorders require a minimum of 0.5 sec to traverse the chart. As any chamber is useable at speeds up to 10 sec/pulse and the DRA runs the recorder tapes through at a 100-to-1 speed up, pulses can occur at a minimum spacing of 0.1 sec. So even though computations could be made rapidly enough, the points could not be plotted that rapidly. Consequently, it was necessary to use a decade scaler between the pulse input and the dose rate computer. Each chamber covers 2 decades, and the decade prescaler is only used for the upper decade. Therefore, the minimum pulse spacing into the dose rate computer is 1 sec and the maximum is 10 sec. The 1-sec minimum allows time to print the solution to the previous computation and reset the binary chain. The conductance matrix associated with the binary chain is so adjusted that zero count in the binary chain gives an output reading of 36 mr/hr, or 360 mr/hr or 3.6 r/hr.

The DRA has performed remarkably well, considering the rapidity with which it was developed, designed, and fabricated. The unit has been operable approximately 90 percent of the time. Approximately 140 vacuum tubes, many of which are dual tubes, are used. Because of the time available, it was sometimes necessary to omit maintenance aids and consider just the ease of fabrication.

## Appendix G

# SUPPLEMENTARY MATERIAL ON RADIOLOGICAL SURVEYS AND FALLOUT PHOTOGRAPHY

### G.1 INSTRUMENTATION

Radiacs, a directional beta detector, a directional gamma detector and wipe-sampling equipment were procured and shipped to the test site for the radiological surveys of Operation Castle. A brief description of these instruments, together with calibration and maintenance data and an evaluation of their performance, follows.

G.1.1 Radiacs. Three types of standard radiacs were used in the surveys: 25, AN/PDR-T1B; 12, AN/PDR-18A; and 25, AN/PDR-27C.

G.1.1.1 AN/PDR-T1B. This instrument (Reference 28) is the ion-chamber type, with five ranges from 5 mr/hr to 50,000 mr/hr fullscale and measures gamma radiation only. It is nondirectional, has a range switch, zero set, and operational check with built-in source, and operates from batteries (two special, two radio type). All the instrument switches were modified.

Calibration. The instruments were calibrated approximately every 2 weeks on a Co<sup>60</sup> gamma range (UDM-1 Radiac Calibration Set). Mid-scale intensities for each range were utilized, i.e., 3 mr/hr, 30 mr/hr, 300 mr/hr, 3,000 mr/hr, and 30,000 mr/hr. Actual readings were recorded for future comparison since the factory (Reference 28) guaranteed no more than the  $\pm 15$  percent at  $4/5$  fullscale. Most instruments were better than this.

Maintenance. Practically none required. Instruments were occasionally dropped; such accidents resulted in one broken chamber mount and several damaged meter movements. No battery failures occurred. Salt water spray caused rusting of the outer steel case where there was a poor paint film. It also caused some of the control shafts to stick. All repairs were made in a dehumidified room.

Evaluation. This radiac was the best available for this particular operation. It was simple to operate even with its zero adjust; very dependable if it worked at all; had the longest battery life of any of the radiacs; ranges of 5 mr/hr to 5,000 mr/hr were used principally; there was close correlation of readings among instruments; some difficulty was experienced in reading meter at 10 percent of fullscale because the switch was over this point.

Recommendations. This instrument is highly recommended for gamma field measurements. Only fresh batteries should be installed. A shoulder strap with reliable clips should be used to carry this instrument safely.



G.1.1.2 AN/PDR-18A. This instrument (Reference 29) is the scintillation type with internal photomultiplier tube, using 4 ranges, 0.5 r/hr to 500 r/hr fullscale. It measures gamma radiation only, is relatively nondirectional, has a range switch, zero set, calibration set, and operates from common flashlight dry cells (BA 30).

Calibration. All instruments were calibrated every 2 weeks with Co<sup>60</sup> gamma range; midscale readings were checked on each range; the 500 r/hr range was not checked.

Maintenance. None required.

Evaluation. This instrument not used because useable ranges were too high; the instrument could not be calibrated with internal source in a gamma radiation field such as that encountered on the test ships.

Recommendations. Not recommended for future operations. The AN/PDR-18 or 18B would be useful only if intensities higher than 50 r/hr were to be measured.

G.1.1.3 AN/PDR-27C. This is a double tube instrument with four ranges from 0.5 to 5 mr/hr using a G-M tube probe detector and 50 to 500 mr/hr using an internal G-M tube. It measures beta and gamma radiation with the probe, and gamma only on the two higher ranges. It has nondirectional gamma sensitivity. A range switch is the only control; the instrument operates from dry cells (three special types).

Calibration. All operating instruments were calibrated approximately every 2 weeks with Co<sup>60</sup> radiation. Mid-scale intensities for each range were utilized except where gamma background on Parry Island was above 10 percent of full-scale reading (background was as high as 10 mr/hr).

Maintenance. Battery failures occurred very frequently, particularly the BA-401/U and BA-416/U. New batteries were installed in each instrument before shipping, but when checked 3 months later at the test site, 8 instruments had defective batteries, and by the end of the operation, all batteries had to be replaced. The BA-401/U batteries leaked so that their holders had to be washed and carefully dried to remove and prevent corrosion. There were other maintenance problems because instruments were seldom used.

Evaluation. The short operating life in tropical climate was caused primarily by battery failure. Instrument was not suited for personnel monitoring because probe ranges were too low (only 5 mr/hr, when the background was often 5 mr/hr or more); it was not completely useable for shipboard monitoring because many intensities were higher than the 500-mr/hr upper limit of the instrument. The PDR-27C was a complete misfit, and as a result was used very little.

Recommendations. Not recommended for field tests unless radiation levels below 5 mr/hr are to be encountered. If personnel monitoring is to be accomplished, a side window G-M instrument like the MX-5 would be preferable.

G.1.2 Directional Beta Detector. The directional beta detector is a twin air ion chamber type instrument with gamma bucking circuit. The instrument (Reference 29) shown in Figures G.1 and G.2 was made at NRDL

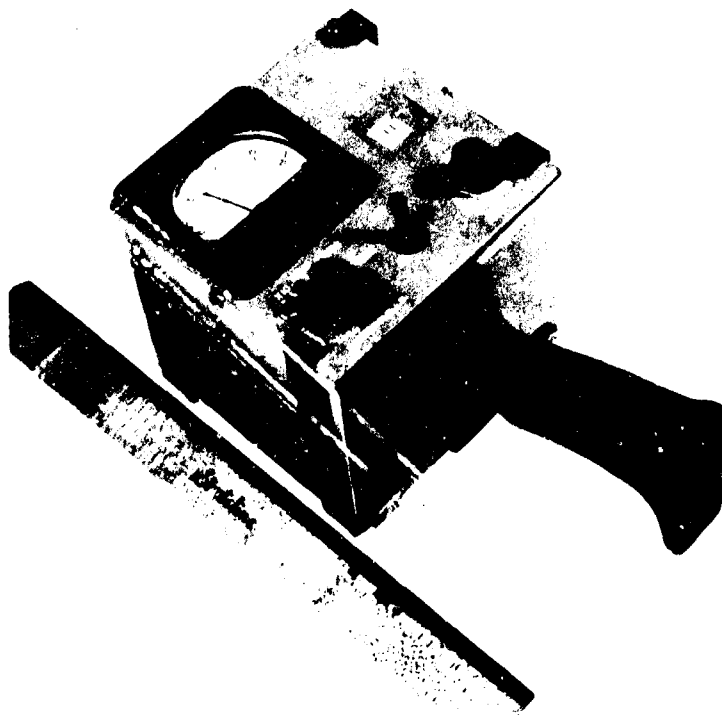

Figure G.1 Beta directional instrument, RBI-12.

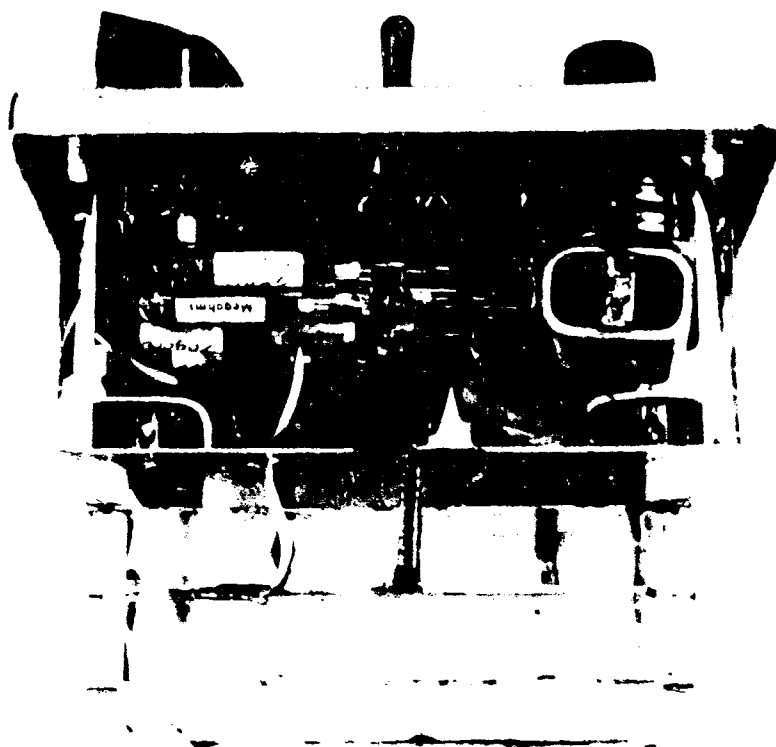

Figure G.2 Beta direction instrument with case removed to show electronic components and double bucking ion chambers.

and has four ranges from 20 to 20,000 microcuries equivalent of strontium-yttrium 90, meter readings from 0 to 20  $\mu$  amp and ranges from X1 to X1000. It measures beta radiation only from an area 10 by 10 cm when placed 1 cm above the surface to be monitored. It contains one BA-30 battery, two 30 and one 15 hearing-aid batteries, has an on-off switch, range switch, and zero controls. It is covered with a polyethylene bag 2 mil thick which is held in place with a removable clip. Twelve of these instruments were used at the site.

Calibration. Each instrument was checked on beta-calibration buttons before each day's monitoring operations. Four  $\text{Sr}^{90}\text{-Y}^{90}$  standards which permitted midscale checks on each range, i.e., at 10  $\mu\text{c}$ , 100  $\mu\text{c}$ , 1000  $\mu\text{c}$  and 10,000  $\mu\text{c}$  were used. These data were recorded and compiled thereby permitting a continual check on the performance of each instrument. The same backing material (wood) had to be used for mounting the beta buttons to keep the back-scatter uniform.

Maintenance. These instruments were excellent electronically but fragile mechanically. The most common causes of failure were unsoldered chamber and battery connections, broken lucite and glass stand-off insulators and chamber separators, window breakage, range switch and toggle switch failure, and several 20  $\mu\text{c}$  meter movement breakages. The loose connections were easily resoldered, the separators were remade of brass and the insulators of phenolic plastic instead of lucite. Switches were cleaned, or replaced (toggle only). There were few 30-v chamber batteries replaced, no 15-v, and few 1.5 v A cells. No tubes needed replacing. Broken windows were restraightened and used even though torn. All repairs were conducted in a dehumidified room, and the instruments were stored there until sealed in polyethylene bags. Torn bags in the field allowed the instruments to absorb moisture resulting in high readings.

Evaluation. This instrument was the only one available which would read localized beta radiation in a high gamma field. The meters were easy to read; the data were recorded as actual meter readings plus range scale position (e.g. x 10). It was easy to operate despite zero adjust, however a carrying strap would have been helpful; the sensitivity range was adequate for this operation, few readings were offscale on X1000 scale and few were below 1  $\mu\text{a}$  on the X1 scale, the meter time constant was satisfactorily rapid on all but the X1 scale, linearity was excellent, the instrument holds zero setting very well; there was a very slow calibration drift of about 6 percent per month. The correlation of readings between instruments was fair, however, calibration factors were calculated for each instrument based on the calibration data, and the monitoring data were corrected with these factors (ranging from 0.80 to 1.1). They were also sufficiently insensitive to gamma for practical use, see Table G.1. These instruments were assembled just before shipping to the test site, and no preliminary testing was possible. Many of the mechanical weaknesses would have been corrected if sufficient laboratory testing had been possible. The electronic circuit, size, and weight were excellent. Aside from the mechanical failures, the operational life could be considered to be about the same as the T1B. X100 and X1000 scales were insensitive to gamma radiation from 0 to 20 r/hr.

TABLE G.1 GAMMA SENSITIVITY OF BETA PROBE

Gamma Intensity (mr/hr)	Beta Sample 1 X1 Scale	Beta Sample 2 X10 Scale
0	9.3	5.3 x 10
10	9.5	5.3 x 10
50	9.5	5.3 x 10
100	10.0	5.3 x 10
200	10.3	5.3 x 10
500	12.2	5.3 x 10
1000	15.0	5.9 x 10
2000	17.2	6.0 x 10
5000	19.5	6.5 x 10
10000	-	7.5 x 10
20000	-	9.3 x 10

### Recommendations.

1. The instrument should be of sturdier construction.
2. Twice the number of switch points or sensitivity ranges should be added i.e., X1, X3, X10, and X30.
3. Carrying cases and straps for the instruments should be provided.
4. The bag clip and stand-off feet need improvement.
5. A power supply using only flashlight type dry cells (BA-30) should be designed.
6. A similar instrument with greater sensitivity (10-50 times) should be designed for monitoring industrial decontamination operations at shipyards.
7. The NRDL RBI-12 or similar instrument should be used in future field operations to determine decontamination efficiency.

G.1.3 Directional Gamma Detector. Two directional gamma detectors, designed and fabricated at NRDL, were completed just prior to shipment to the test site. The directional gamma detector shown in Figures G.3 and G.4 consists of a small G-M tube shielded by a lead sphere, 6 in. in diameter with 60° conical "window". The sphere is mounted on a tubular steel stand 30 in. high which also holds the electrometer case and calibration button. When the detector is directed downward, it covers a circular area of about 7 sq ft. Only the gamma rays inside this circular area are seen by the G-M tube and except for about 1 percent leakage through the lead shield are detected. This "background" is measured and subtracted by inserting a brass covered lead plug in the conical window. The calibration button ( $\text{Co}^{60}$ ) is also held on the end of the plug when the instrument is calibrated. The electrometer case has a control panel including an indicating meter, a range switch, zero set, on-off switch, calibrating screw (potentiometer), and G-M tube cable connectors.

Calibration. Both instruments were calibrated on gamma range before each operation. During primary calibration each instrument was made to read 25 on the "C" scale at a radiation intensity of 25 mr/hr. The gamma button was then placed on the end of the lead plug and inserted in the spherical shield. It usually read about 20 on the "B" scale. Primary calibration was then continued and meter and scale readings were plotted

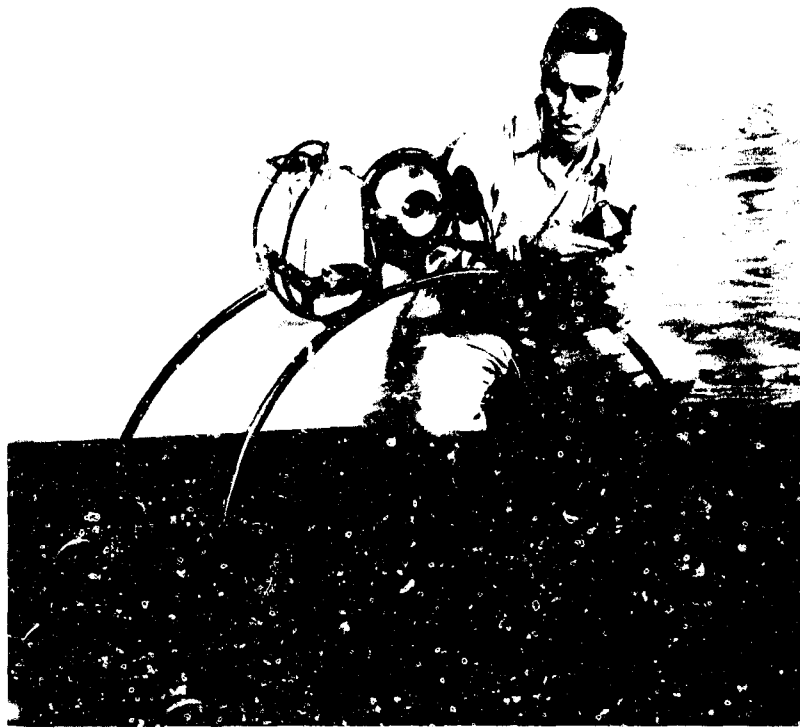

Figure G.3 Directional gamma detector, RGG-1. Shown are the tubular steel stand, spherical GM tube shield, shield plug in operator's hand and electrometer box.

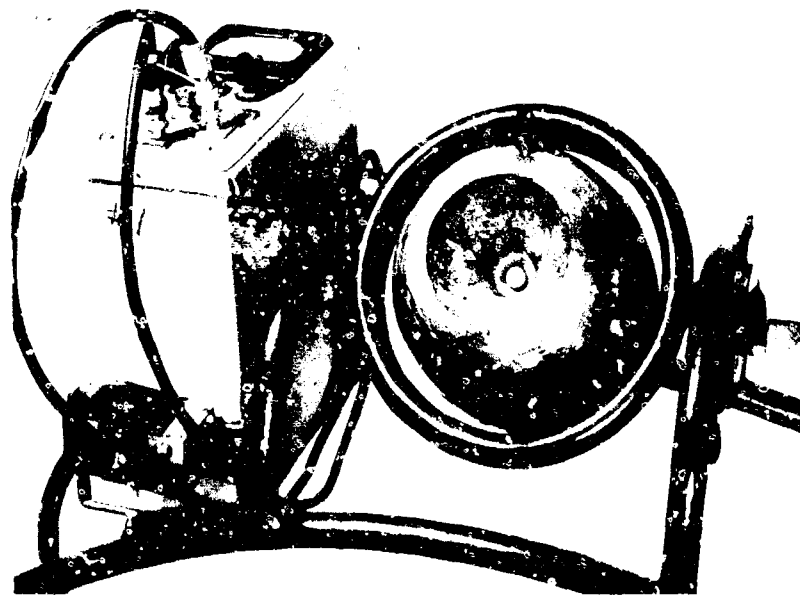

Figure G.4 Close-up of directional gamma detector, showing GM tube in center of spherical shield. Gamma calibrating buttons are carried in small plastic box near the electrometer.

against actual radiation intensities. The instrument was quite nonlinear. All monitoring data were recorded as meter reading and scale setting, and later converted to mr/hr by consulting the calibration curves. During actual monitoring operations it was necessary to check the calibration every few minutes with the gamma button. A screw driver was used to rotate the calibrating screw which adjusted the voltage applied to the G-M tube until the meter read the predetermined value (20 on "B" scale) found during primary calibration.

Maintenance. No serious maintenance problems aside from replacing two G-M tubes, and cleaning and drying the high voltage cables which developed current leaks after being exposed to salt water spray. The internal batteries lasted for the entire operation.

Evaluation. In general, the gamma probe was not considered satisfactory in its present stage of development. Its weight and bulk made it very difficult to handle aboard ship. Two readings plus reference to calibration curves were required to record a single radiation measurement. The instrument was very voltage dependent, and to maintain accurate calibration, it was necessary to reset the G-M tube voltage before each measurement, which further decreased the speed of operation. Constant handling of the Co<sup>60</sup> gamma button, carried with the instrument, resulted in the source holder (plug) becoming contaminated and rendering subsequent measurements uncertain. The nonlinearity of the instrument made meter readings and scale settings difficult. The instrument was satisfactorily directional, but the G-M tube had too small a volume for stability at low intensities. The energy dependency was never checked, so the correlation between readings on the Co<sup>60</sup> gamma calibration range and measurements of mixed fission products is questionable. Because of the slowness of its operation, excessive dosage was received by the operators. Because dosage was at a premium, few directional gamma measurements could be taken.

Recommendations. Not recommended for field operations.

G.1.4 Wipe Sampling Equipment. The wipe sampling equipment consisted of five special samplers, filter papers, No. 10 rubber stoppers, beta buttons, lead castle, gas flow proportional probe, special laboratory type rate meter and a decimal scaler. The special wipe sampler consisted of a filter paper holder which applied a fixed pressure to the wipe papers; a bag opener for facilitating the dropping of the wipe sample in a protective plastic bag; and a box for storing and carrying the filter papers and plastic bags (Figures G.5 and G.6). In very windy locations it was necessary to hand-hold the filter paper wipes and apply wiping pressure with a No. 10 rubber stopper.

The wipes were monitored with either a proportional probe with a laboratory rate meter or counted with a G-M tube and a conventional Atomic Model 105 scaler. A beta button standard was used to determine the efficiency of the counting equipment. All counting was done in a lead castle to minimize background radiation.

Calibration. The efficiency of the wipe samplers was never determined. The counting equipment was calibrated with a beta standard before



Figure G.5 Automatic pressure regulated wipe sampler.



Figure G.6 Wipe sample kit, including filter paper, rubber stopper pressure applicator.

and after each group of samples were monitored. Background counts were taken after each 20 samples.

Maintenance. The double sided pressure sensitive tape was renewed regularly on wipe samplers. Window on proportional probe was broken and no replacement was made. The Atomic Model 105 scaler was moisture sensitive and had to be left running 24 hr a day to maintain its accuracy. Several tubes were replaced, and the register relay was repaired on the Atomic scaler.

Evaluation. The wipe samplers were satisfactory except when used in the wind, which blew the filter paper off the double coated pressure sensitive tape. The rate meter with gas flow probe would have allowed more rapid monitoring of the wipe sampler, but early breakage of the probe prevented its use. Extreme sensitivity in a G-M tube was not needed in field type wipe sample counting because contamination levels were normally high. Semi-automatic decimal scalers like the Atomic scaler definitely facilitated sample counting. It was found that with a little training, nontechnical personnel could operate all of the wipe sampling and counting equipment satisfactorily.

#### Recommendations.

1. The present wipe sampler should be improved, and used in future operations to obtain uniform wipe sampling.
2. The efficiency of the wipe sampler should be determined for various surfaces.
3. Rate metering equipment for wipe samples should be perfected and used in future operations.

#### G.2 SURVEY STATION LOCATIONS

The locations of the surveys taken aboard the experimental ships are shown in Figures G.7 through G.9 and in Table G.2.

#### G.3 PRELIMINARY WORK ON FALLOUT PHOTOGRAPHY

It was anticipated that the fallout to be photographed on the YAG 40 would be in the form of a rain or a fog such as the rainout and base surge experienced at Bikini "Baker". It was estimated that the fallout would occur within the first 4 hr after shot time. Since radiation levels on the ships were assumed high enough to give 10,000 r total dose gamma radiation over a week's time, shielding the camera's film to minimize fogging presented a problem.

The following conditions were considered necessary to insure satisfactory photographs of the fallout arriving at the YAG 40: (1) stoppage of practically all particle motion; (2) sufficient illumination for 10  $\mu$  particles and larger; (3) adequate resolution for particle size determination and differentiation between liquid and solid particles; (4) sampling period of 4 hr or more; (5) time resolution, 30 sec (interval between pictures); (6) film which was relatively sensitive to light but insensitive to gamma radiation; (7) shielding around film to minimize fogging when



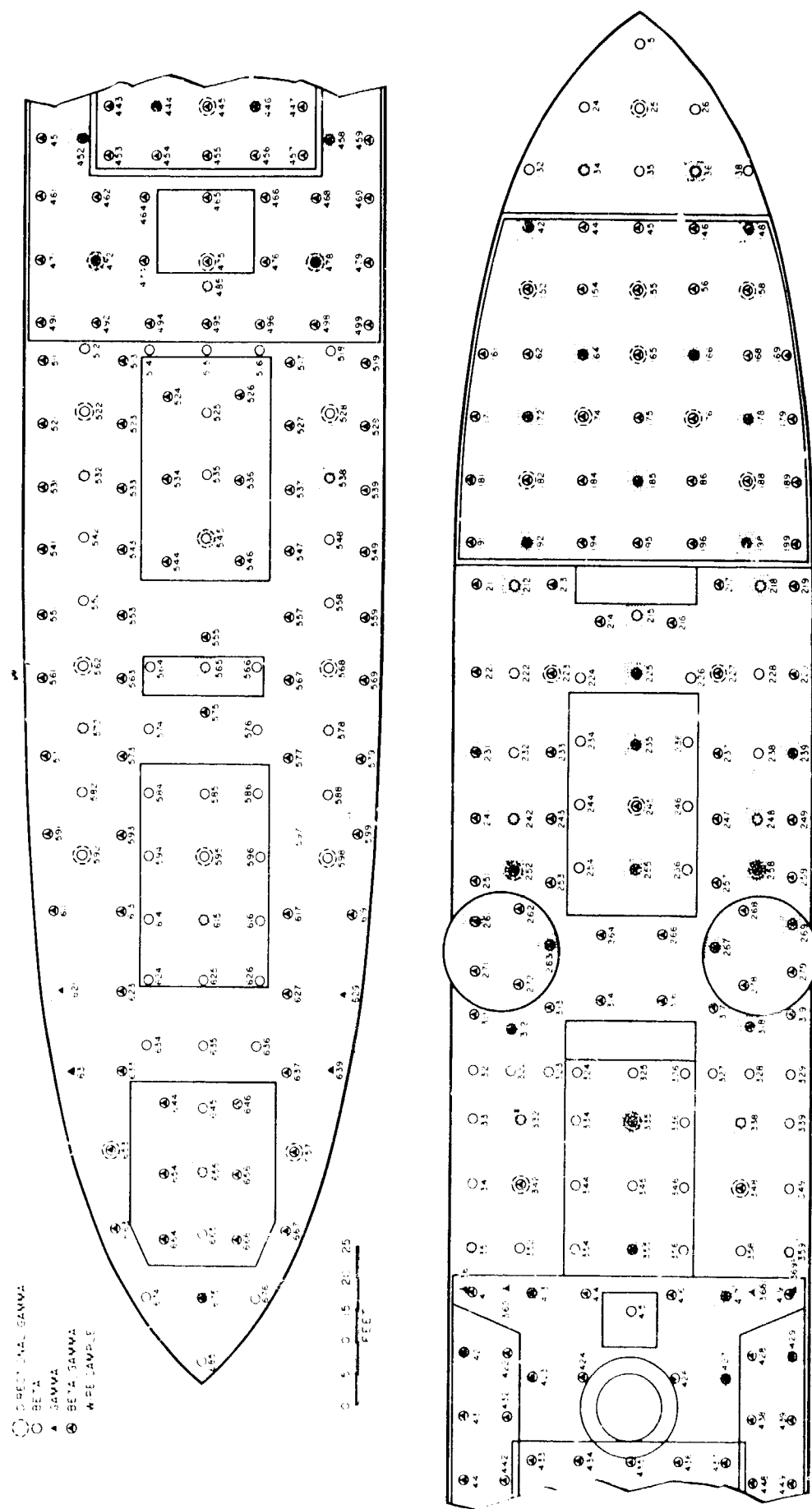
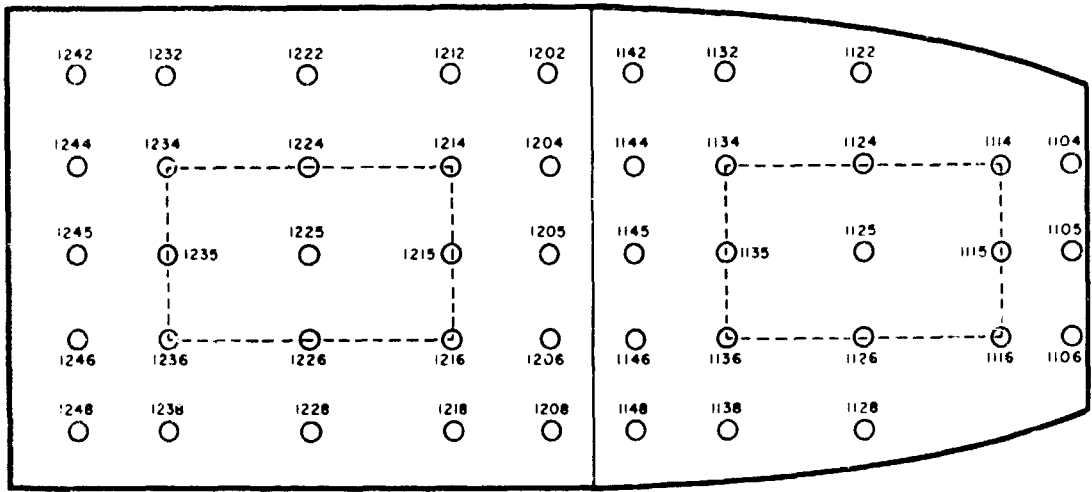
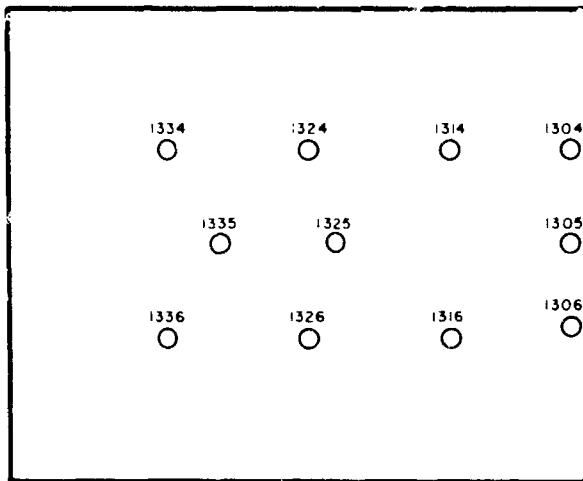

Figure G.7 Location of the stations surveyed on the weather deck.



BETWEEN DECKS 1 and 2 (PLAN)



NUMBER 2 HOLD (PLAN)

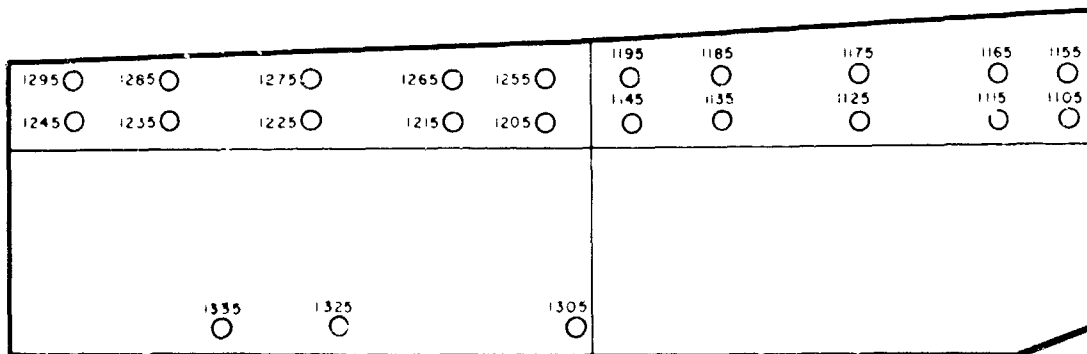

SECTION 1 and 2 (ELEVATION)

Figure G.8 Locations of stations surveyed in Sections 1 and 2 for the shielding studies.

117

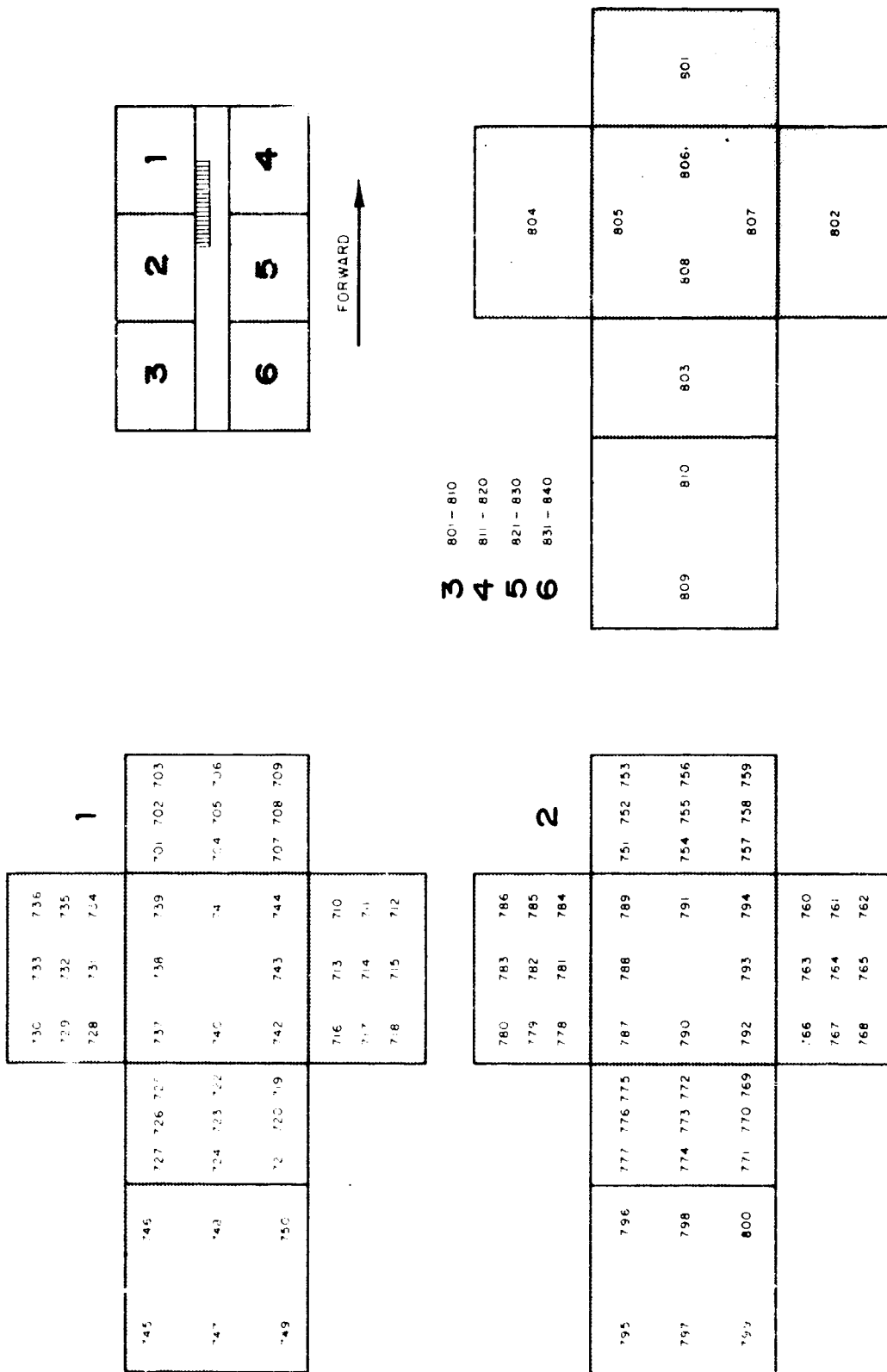

Figure G.9 Location of survey stations in the ventilation cubicles

TABLE G.2 BOILER-AIR SURVEY LOCATIONS

Location Beta Readings and Wipe Samples	Station Nos. Transits	
	BAKER	ABLE
Fwd end of firing aisle	901	951
6" fwd of fwd burner, stbd	902	952
24" above of fwd burner, stbd	903	953
24" above of 2nd burner, stbd	904	954
24" above of 3rd burner, stbd	905	955
24" above of aft burner, stbd	906	956
6" aft of aft burner, stbd	907	957
Log deck at aft end of firing aisle	908	958
6" aft of aft burner, port	909	959
24" above aft burner, port	910	960
24" above 3rd burner, port	911	961
24" above 2nd burner, port	912	962
24" above fwd burner, port	913	963
6" fwd of fwd burner, port	914	964
Directional gamma stations		
Upper dk fwd of boiler fidley	917	967
Upper dk stbd of boiler fidley	918	968
Upper dk stbd of boiler fidley	919	969
Upper dk port of boiler fidley	920	970
Boat dk fwd of boiler fidley	921	971
Boat dk stbd of boiler fidley	922	972
Boat dk aft of boiler fidley	923	973
Boat dk port of boiler fidley	924	974
Gamma Stations		
Port of boiler air intake duct 8' above elbow	925	975
Below boiler air intake duct 8' above elbow	926	976
Aft of elbow, air intake duct	927	977
Below elbow, air intake duct	928	978
Aft of boiler air intake duct, top of engine casing level	929	978
Below boiler air duct, top of engine casing level	930	980
Aft of boiler air duct 12" above lower transition piece	931	981
Below boiler air duct 12" above lower transition piece	932	982
Btwn 1st and 2nd burner, 36" from dk stbd	933	983
Btwn 1st and 2nd burner, 36" from dk port	934	984
Btwn 3rd and 4th burner, 36" from dk port	935	985
In boiler fidley	936	986
Bridge dk fwd of fidley	945	995
Bridge dk stbd of fidley	946	996
Bridge dk aft of fidley	947	997
Bridge dk port of fidley	948	998

exposed to the gamma radiation doses anticipated; (8) small camera, so as to require the minimum size of shielding; (9) sufficient film capacity in camera for about 500 frames or individual pictures without reloading or rewinding; (10) means of synchronizing the camera shutter to the electronic flash lamp; and (11) means of starting and stopping the entire system automatically.

In preliminary laboratory tests to determine the type of film to be used, various common films were exposed to increasing gamma dosages ( $\text{Co}^{60}$ ) and the resolution of the film was plotted against gamma exposure. The

Eastman Kodak Special Order 918 film proved to be the best for the anticipated conditions.

Various light-concentrating mirrors were tested to determine the correct focal length to use and the optimum placement of mirror and electronic flash lamp. The best combination was an elliptical mirror, with the flash lamp at the far focal point and the target volume at the near focal point. In this way a very intense beam of light of 1/2000 sec duration was produced. This beam was capable of illuminating and partially stopping rapidly falling droplets as well as fine mists and powders.

Figure G.10 is a photograph of falling water droplets produced by an

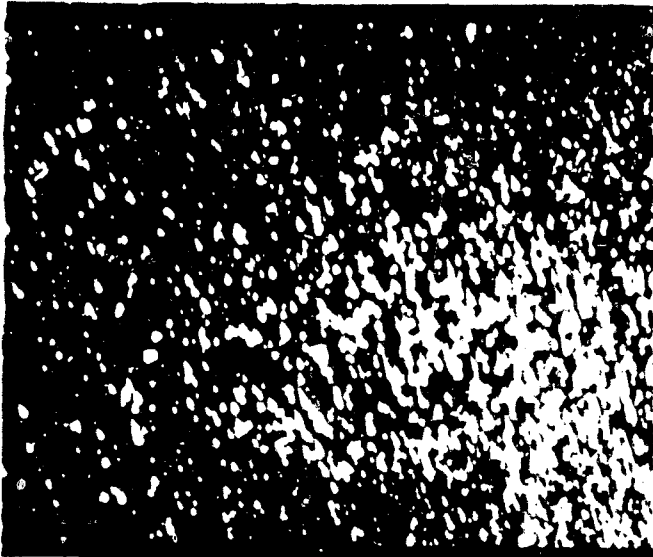
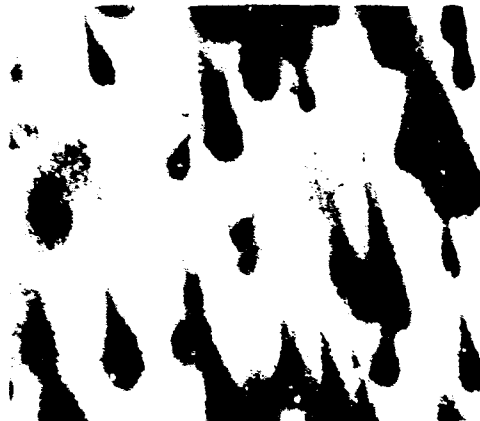

Figure G.10 Water spray, enlarged (7.3 X) from an aerosol camera frame.

atomizer. Figure G.11 is a photomicrograph of a small area of Figure G.10. Note the tear drop shape which was caused by the uneven output of the flash lamp. When the flash lamp discharges, it emits very intensely at first but immediately diminishes for a fraction of a millisecond. The image of the particle appears largest when the illumination is brightest and the image shrinks toward the end of the flash tube's discharge. With moving particles a tear drop shape is always produced with the tear drop

Figure G.11 Photomicrograph (90 X) of a section of Figure G.10 showing characteristic tear-drop images of rapidly moving water particles.



pointing in the direction of movement. This same effect was noted with solid as well as liquid particles. Rain drops show characteristic paired images of the highlights caused by reflections from the flash lamp and mirror on either side of the drop. This appearance is a possible way of

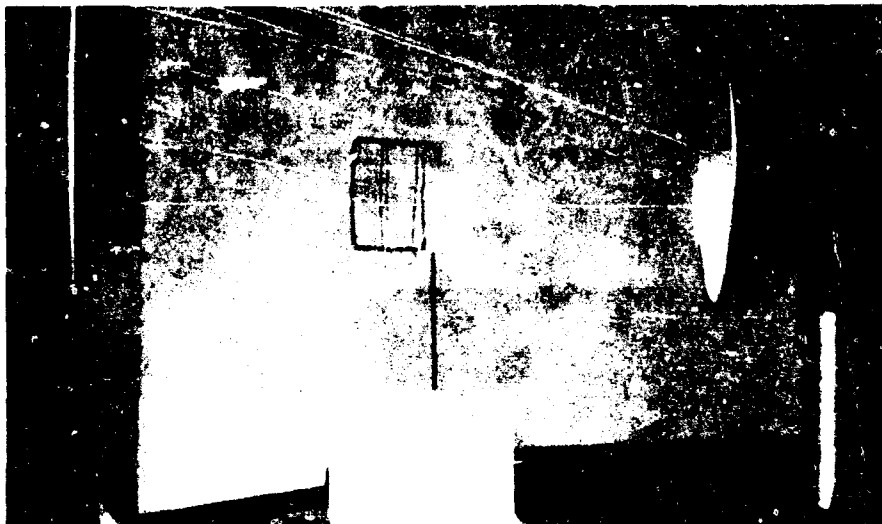

Figure G.12 Wires photographed at an initial 12:1 reduction illuminated by ordinary room light. The 1 and 0.5-mil wires are barely discernible. Enlarged 0.9 X actual size.

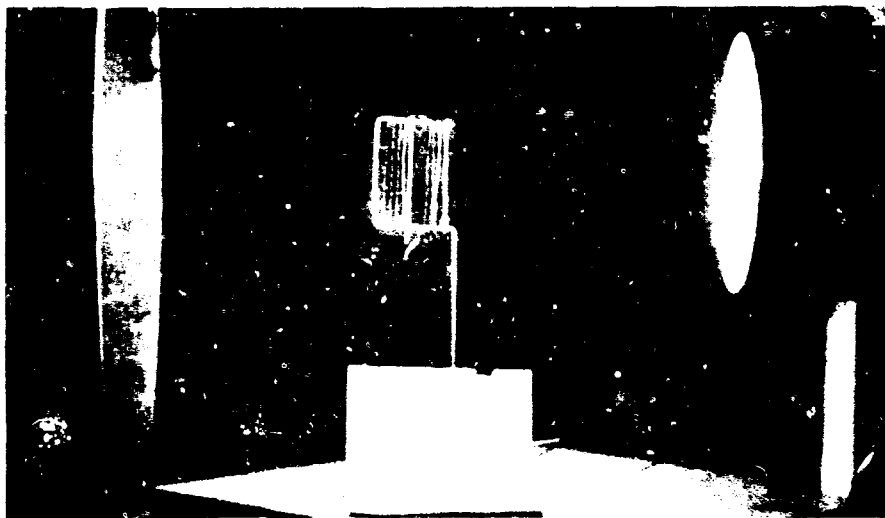

Figure G.13 Same wires photographed as above but illuminated by a single flash discharge from the electronic flash lamp. All wires are intensely recorded. Enlarged 0.9 X actual size.

differentiating large solid from large liquid particles. The images of small water droplets merge into a single recorded spot as shown in the figures.

Using the initial laboratory setup and the shipboard installation, pretest photographs were made of coarse and fine mists, fogs, smokes and

coarse and fine particles from solid aerosols. In all these cases, however, the number of particles per unit volume of air was fairly high, such as would be encountered in a heavy rain, fog, or dust storm. A series of fine wires were photographed with the aerosol camera to obtain a rough calibration of the magnification of the system so as to determine whether it would be possible to estimate particle sizes from image sizes. Actual magnification on the film was  $1/12$  x. Figures G.12 and G.13 show the frame holding two sets of wires whose sizes were 30, 10, 4, 1, and 0.5 mils, nominally, or about 750, 250, 100, 25, and 12  $\mu$  in diameter. The width of the images was measured with a microscope equipped with a micrometer ocular. When image width was plotted against actual wire size, a straight line was obtained down to the 4-mil (100  $\mu$ ) wire. Below 4 mils the image width remained nearly constant, but its intensity diminishes. The 12  $\mu$  wire is still very intensely recorded, so it may be assumed that while particle size determinations below 100  $\mu$  may not be estimated, certainly, the system is able to record diffraction of particles as small as 10  $\mu$  and, perhaps, as small as 2  $\mu$ .

## Appendix H

# ESTIMATION OF RADIATION FLUX ABOARD YAG 40 DURING RECOVERY OPERATIONS

### H.1 THEORETICAL CONSIDERATIONS

To estimate the radiation flux aboard the YAG 40 on the basis of dose rate measurement taken at some distance from the YAG, it is necessary to have some concept of the relationship of the radiation flux and distance. As a first approximation, the YAG 40 was considered to be a rectangular source and the following equation (Reference 31) was used:

$$I = K \times \frac{S_A}{4} \log_e \frac{WL + a^2}{a^2}$$

where I = radiation flux (r/hr)  
K = conversion factor ( $1.92 \times 10^{-6}$  in this case)  
S<sub>A</sub> = activity per unit area (mev/sq cm/sec)  
W = width  
L = length  
a = distance from source

By substituting appropriate numbers and then normalizing these to the radiation flux at 1 ft, the curve shown in Figure H.1 is obtained.

### H.2 EXPERIMENTAL MEASUREMENTS

The following procedure does not produce a precise measurement of the radiation flux. There are many factors that are not accurately measured and there are correction factors that could be applied but were not. The purpose of these measurements was to make an order of magnitude determination of the radiation flux and, as indicated in the body of the report, the results of three separate trials produced this degree of correlation.

To simplify the data taken during recovery operations one person was assigned the responsibility of estimating the relative distance between the YAG 40 and the ATF 106 at various times. Figure H.2 is a plot of these data. All personnel aboard the ATF 106 concerned with dose rate measurements noted the time at which readings were taken. It was then possible to estimate the corresponding distance for each radiation level by using Figure H.2. Figure H.3 is a plot of the radiation flux measured aboard the ATF 106 during recovery operations. While it is noted that there is some randomness to these data attributable to such factors as distance uncertainty, and inherent instrument inaccuracy, it is possible to draw



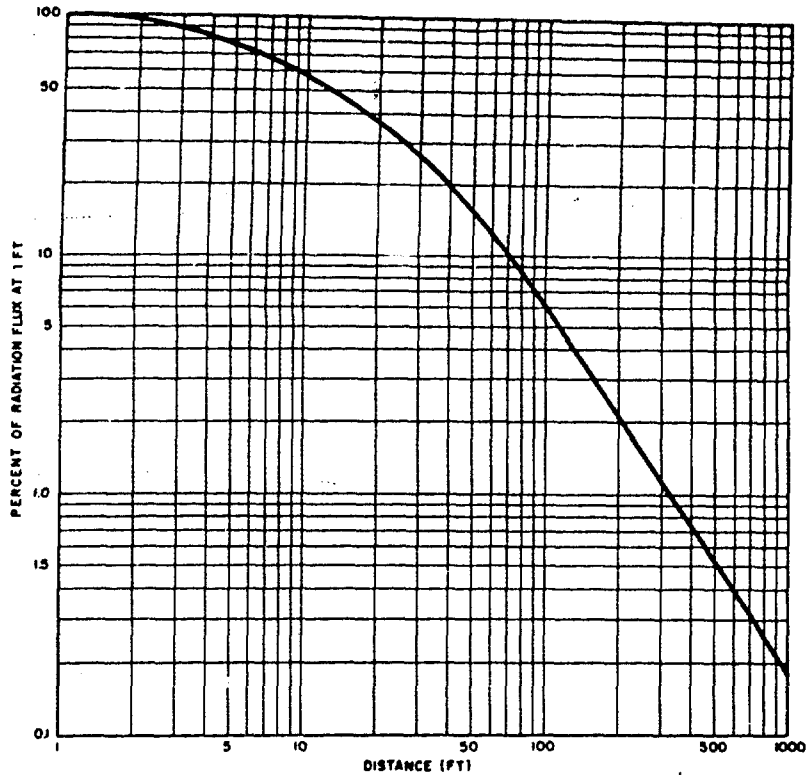

Figure H.1 Percent of radiation flux at 1 ft as a function of the distance from the deck of the YAG 40.

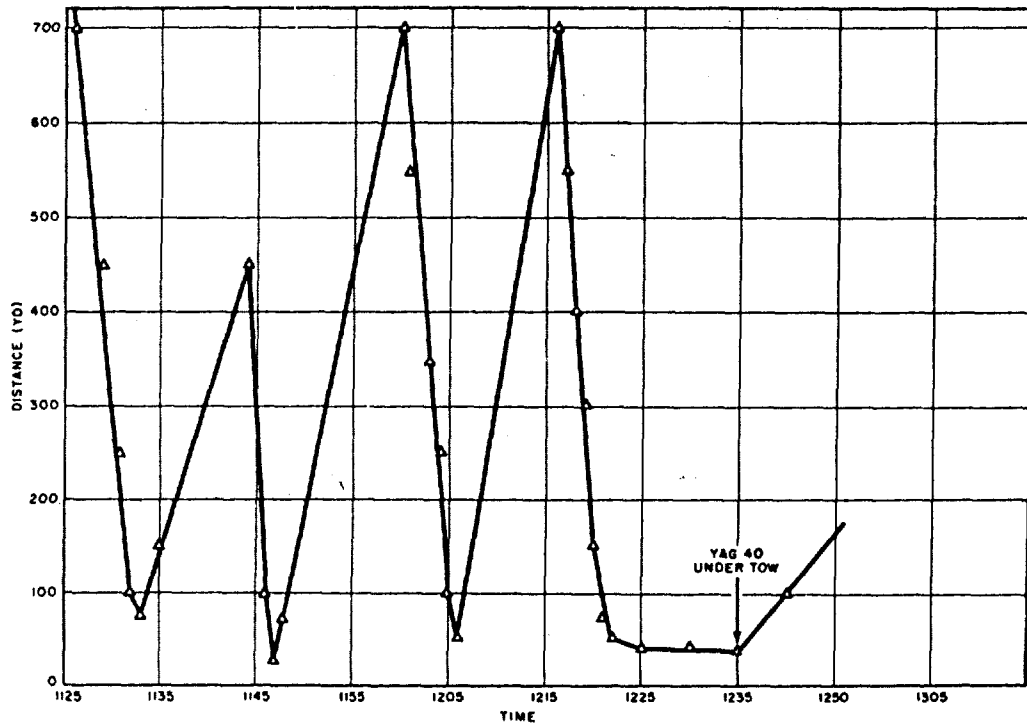

Figure H.2 Distance versus time during YAG 40 recovery after Shot 2.

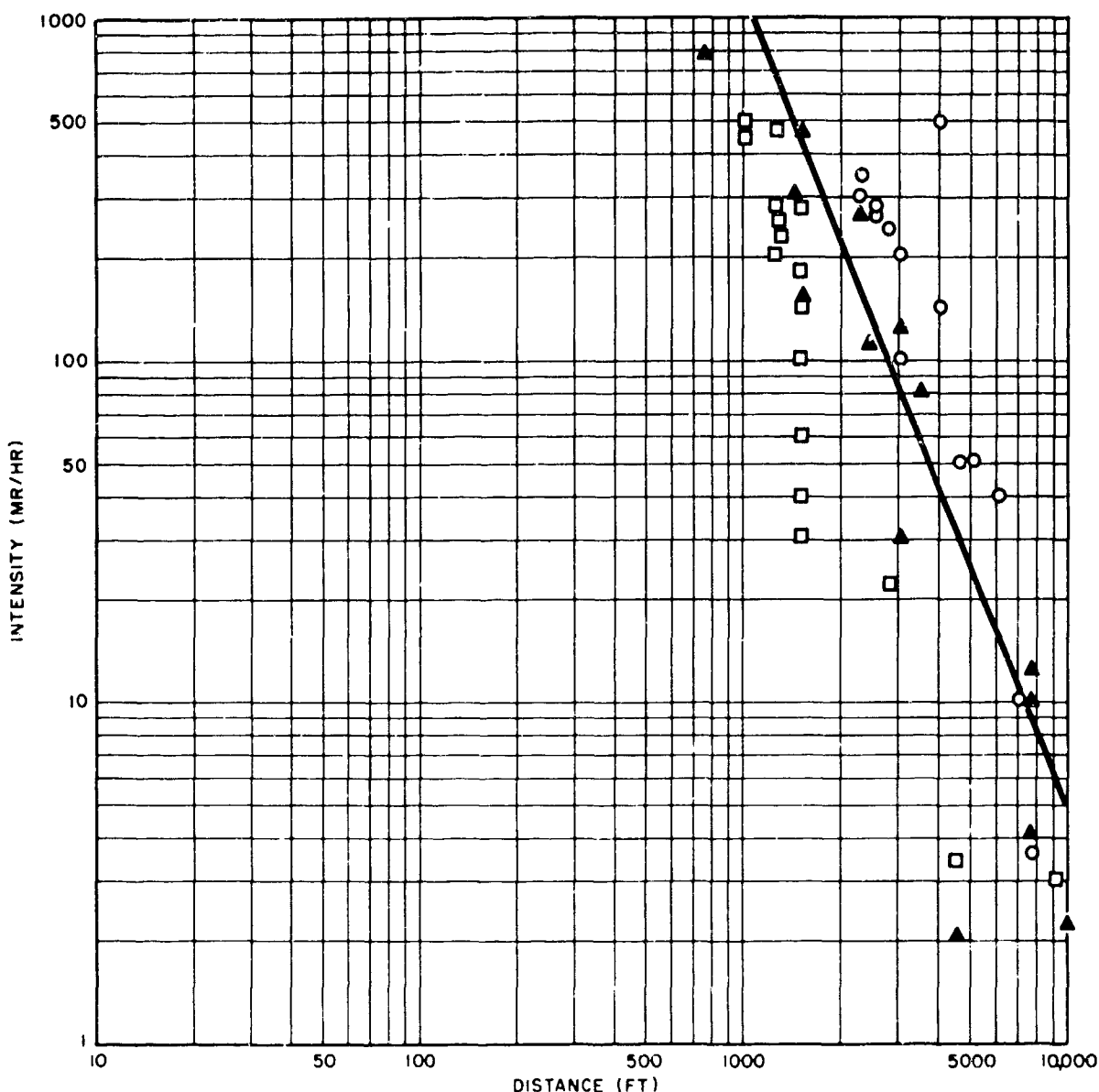

Figure H.3 Radiation flux as a function of distance during YAG 40 recovery after Shot 2.

the straight line shown as a possible relationship for radiation flux versus distance. Comparison of Figure H.3 with Figure H.1 shows that the intensity versus distance pattern for the 100 to 1000 ft distance is a straight line on log-log paper.

Table H.1 presents typical data from corresponding points taken from Figures H.1 and H.3 and the resulting radiation flux at 1 ft on board the YAG 40. These data were not corrected for decay to any given time. They specify levels existing at the time of measurement.

Figures H.4 and H.5 are similar data taken after Shot 4 and Table H.2 presents typical data from Figures H.1 and H.5 and the resulting radiation flux at 1 ft on board the YAG 40. Due to the general background of 30 mr/hr created by the contaminated ocean surface it was felt that readings taken at distances greater than 500 ft were too distorted by the high background to be reliable.

Figures H.6 and H.7 are similar data taken after Shot 5 and Table H.3

TABLE H.1 TYPICAL DATA FOR RADIATION FLUX ESTIMATES FOR SHOT 2

d (ft)	I (Fig. H.3) (mr/hr)	% I <sub>0</sub> <sup>(a)</sup> (Fig. H.1)	I <sub>0</sub> (r/hr) <sup>(b)</sup>
10 <sup>3</sup>	5	0.1%	5
500	30	0.5%	6
300	100	1.2%	8
200	250	2.2%	11
150	400	3.4%	11

(a) I<sub>0</sub> = Established radiation flux at 1 ft from deck of YAG 40  
 $(I_0 = \frac{I}{\bar{X}I_0} \times 10^2)$

(b) Av I<sub>0</sub> = 8 r/hr

presents typical data from Figures H.1 and H.7 and the resulting radiation flux at 1 ft on board the YAG 40.

### H.3 CONCLUSIONS

In order to carry out the above for any ship it is necessary to have available a curve similar to that of Figure H.1 for the ship involved.

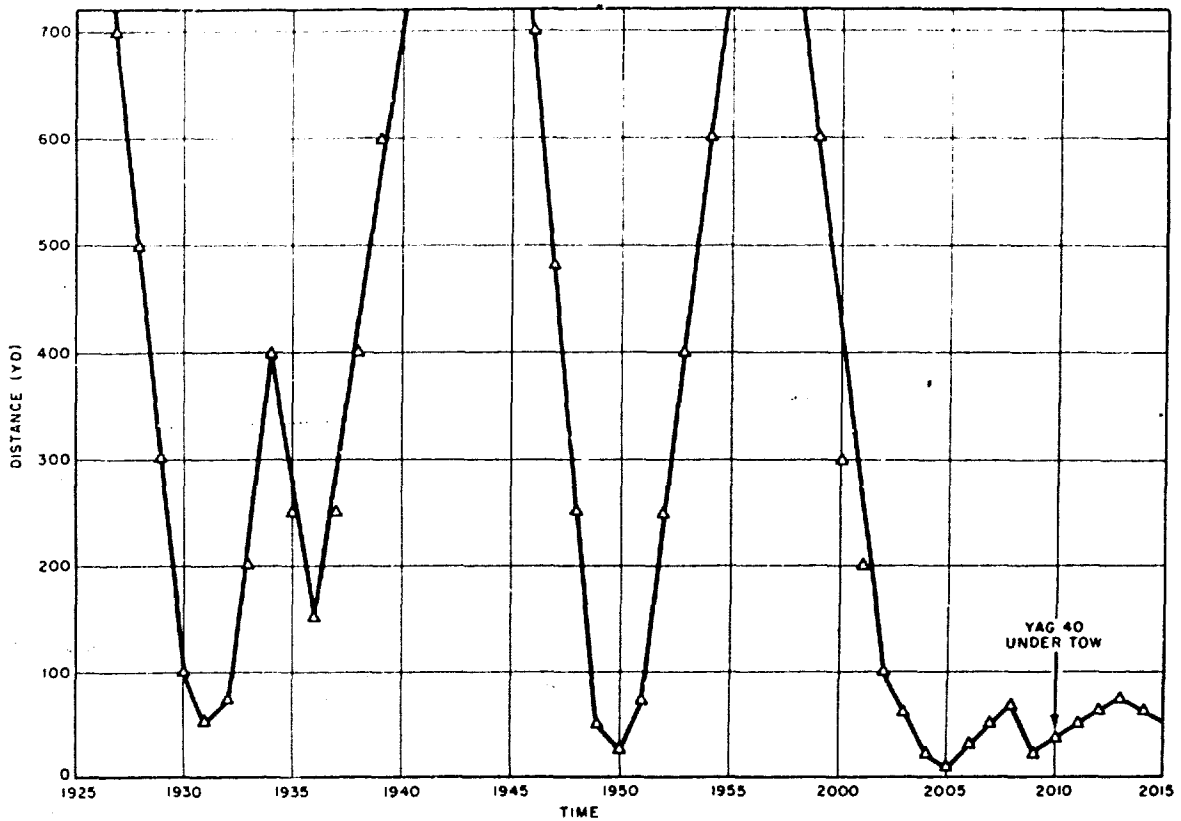

Figure H.4 Distance versus time during YAG 40 recovery after Shot 4.

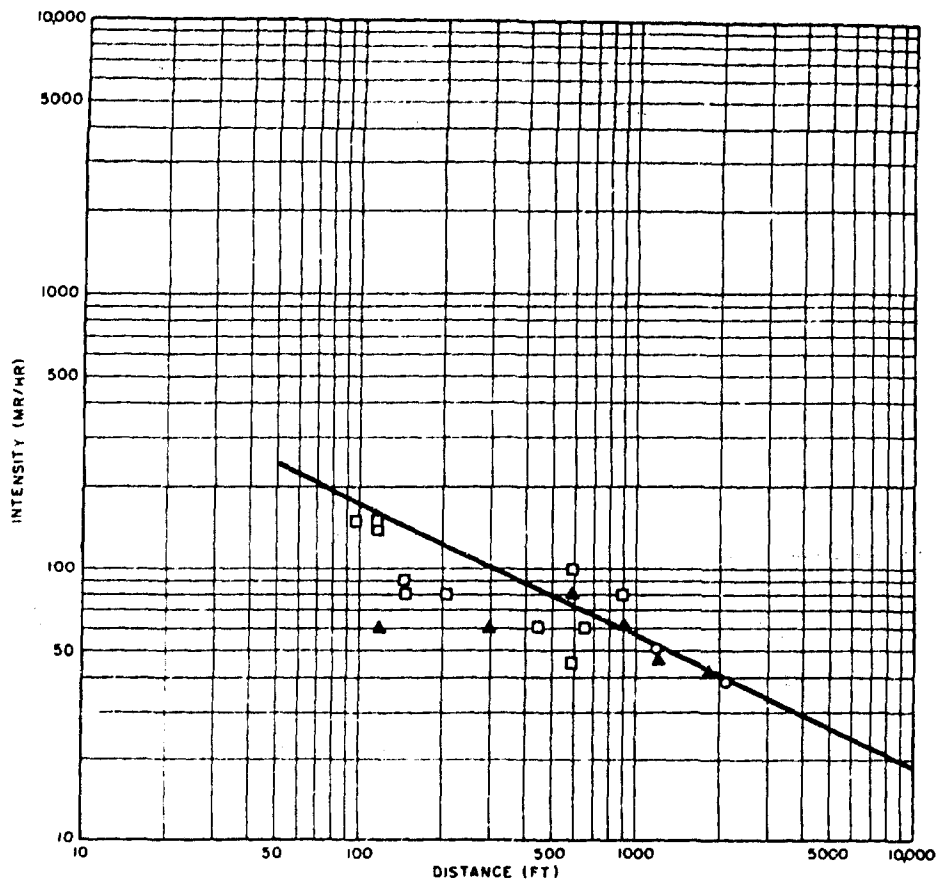

Figure H.5 Radiation flux versus distance during YAG 40 recovery after Shot 4. Measurements include a general background of 30 mr/hr.

TABLE H.2 TYPICAL DATA FOR RADIATION FLUX ESTIMATES FOR SHOT 4

Distance (ft)	I (Figure H.5(a)) (mr/hr)	% I <sub>0</sub> (Fig. H.1)	I <sub>0</sub> <sup>(b)</sup> (r/hr)
300	70	1.2%	6
200	90	2.2%	4
100	140	6.5%	2

Notes: Average I<sub>0</sub> = 4 r/hr

(a) Corrected for Gen. B.G. of 30 mr/hr.

(b) I<sub>0</sub> = Estimated radiation flux at 1 ft from dick of YAG 40

$$I_0 = \frac{I}{\%I_0} \times 100$$

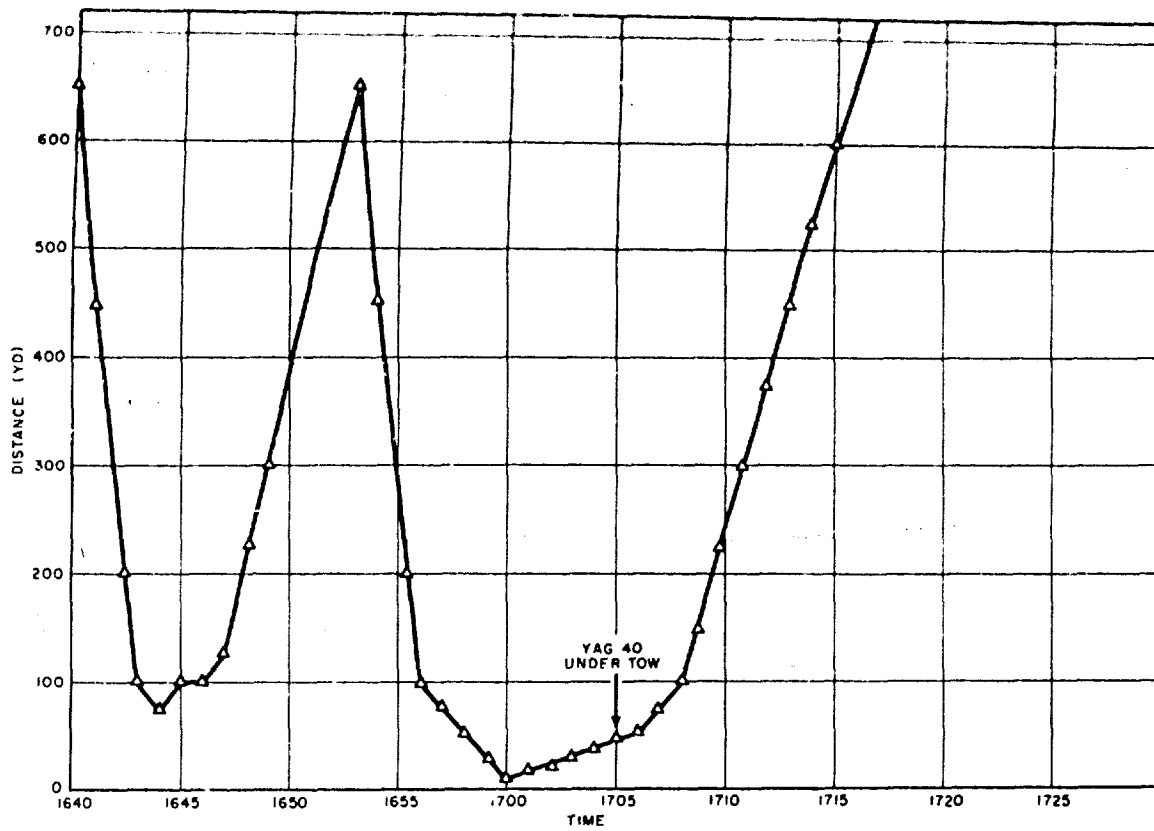

Figure H.6 Distance versus time during recovery of YAG 40 after Shot 5.

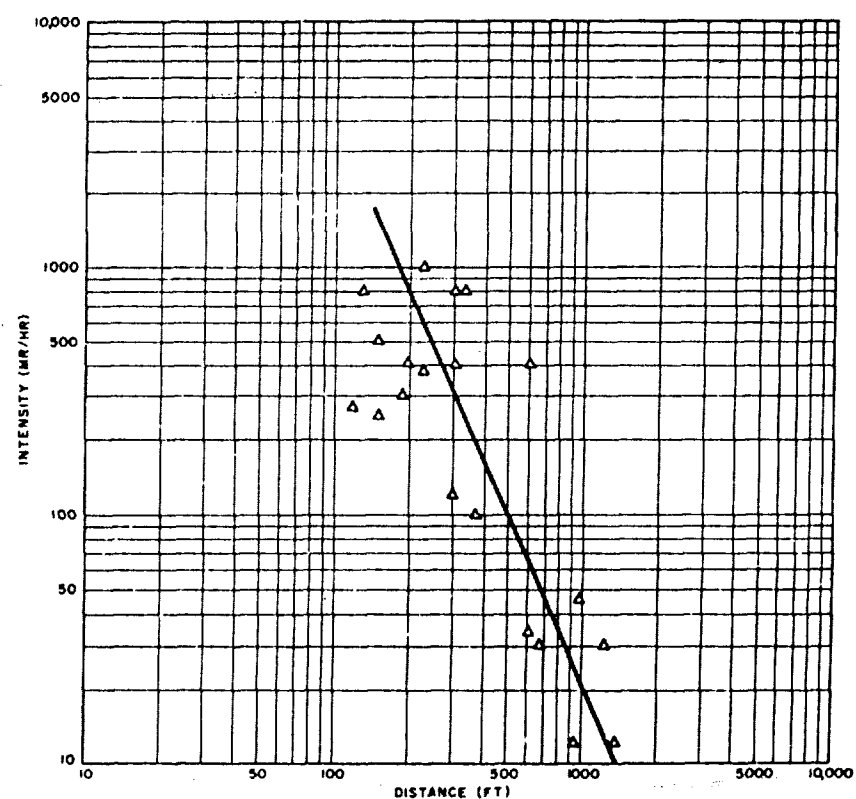

Figure H.7 Radiation flux versus distance during YAG 40 recovery after Shot 5. Flux measurements include a general background of 6 mr/hr.

TABLE H.3 TYPICAL DATA FOR RADIATION FLUX ESTIMATES FOR SHOT 5

d(ft)	I (Fig. H.7) <sup>(a)</sup> (mr/hr)	% I <sub>0</sub> (Fig. H.1)	I <sub>0</sub> <sup>(b)</sup> (r/hr)
1000	14	0.18%	13
600	60	0.4%	15
400	164	0.75%	22
300	309	1.2%	26
200	794	2.2%	36

Average I<sub>0</sub> = 22 r/hr

(a) Corrected for Gen B.G. of 6 mr/hr.

(b) I<sub>0</sub> = Estimated radiation flux at 1 ft from deck of YAG 40.

Obviously this curve will vary in accordance with the ship dimensions. Radiation measurements can be made to determine the relative relationship of radiation flux versus distance from which an estimate of the radiation flux at 1 ft can be made as outlined above.

Since the procedure is for order of magnitude determination only, it will always be necessary for any boarding party to conduct monitoring surveys, particularly to locate any "hot spots." However, it is felt that a procedure similar to that described above can be used to provide a rough estimate of the expected dose rates and serve as an indication of the degree of radiation exposure to be expected during the boarding operation.

Since this system was tried out during Operation Castle on a limited scale (three trials) it would seem in order to conduct additional studies to determine how sensitive the system might be to the variables involved, before a wide scale usage of the procedure is recommended.

## REFERENCES

1. Bigger, M.M., Field Evaluation of Washdown Effectiveness - U. S. Naval Radiological Defense Laboratory Report, USNRDL-361; CONFIDENTIAL.
2. Bigger, M.M., Rinnert, H.R., Sherwin, J.C., Kawahara, F.K., and Lee, H., Field Effectiveness Test of a Washdown System on an Aircraft Carrier - U. S. Naval Radiological Defense Laboratory Report, USNRDL-416; CONFIDENTIAL.
3. Soule, R.R., Stetson, R.L., and Neall, W.G., Efficacy of a Contact Water Curtain in Preventing or Minimizing Contamination - U. S. Naval Radiological Defense Laboratory Report, AD-187(T); CONFIDENTIAL
4. Radiological Decontamination I - Sea Water Prewetting as a Means of Minimizing Contamination - British Report, ARL/R1/C747; CONFIDENTIAL
5. Ksanda, C.F., Cohn, S.M., Shapiro, E.S., Moskin, A., Schmidt, H.C., and Hunter, H.F., Gamma Radiation from Contaminated Planes and Slabs, U. S. Naval Radiological Defense Laboratory Report, USNRDL-TM-27; 15 Feb 1955 UNCLASSIFIED.
6. Stetson, R.L., Schuert, E.H., Perkins, W.W., Shirasawa, T.H., and Chan, H.K., Distribution and Intensity of Fallout Operation Castle. Final Report Project 2.5a Operation Castle WT-915, January 1956; SECRET.
7. Tompkins, E.R., and Werner, L.B., Chemical, Physical and Radiochemical Characteristics of the Contaminant at Operation Castle. Final Report Project 2.6a Operation Castle WT-917, September 1955; SECRET.
8. Teresi, J., Wellhouser, H.N., and Hawkins, M.B., Decontamination of Aircraft. Final Report Project 6.5, Operation Snapper WT-535; UNCLASSIFIED.
9. Vine, F.S., Interim Operational Plan for Tactical Decontamination of Carrier Based Aircraft - U. S. Naval Radiological Defense Laboratory Report, NRDL-447; CONFIDENTIAL.
10. Heilman, F.W., Countermeasure Performance for Carrier Aircraft Operations After a Shallow Underwater Burst - U. S. Naval Radiological Defense Laboratory Report, NRDL-452; CONFIDENTIAL.
11. Vine, F.S., Owen, W.L., Sartor, J.D., and Kehrer, W.S., Methods and Procedures for the Reclamation of Land Targets - U. S. Naval Radiological Defense Laboratory Report, NRDL-407; CONFIDENTIAL.
12. Teresi, J.D., Personnel Radiation Hazards Incident to Ships' Boiler Operation Following an Underwater Atomic Attack - 009668, 11 January 1954. UNCLASSIFIED.

13. Holden, F.R., et al. Radioactive Contamination of Ventilation Supply System, USS CRITTENDEN, from Baker Explosion Operation Crossroads, AD-200(X) February 1950. UNCLASSIFIED.
14. Shnyder, R.W., Significance of Breaks in Integrity of Weather Envelopes of Ships Operating During an Underwater Atomic Attack, 24 March 1954 (to be published). UNCLASSIFIED.
15. Bigger, M.M., Sherwin, J.C., Kawahara, F.K., Boiler Air and Ventilation Tests (to be published). UNCLASSIFIED.
16. Wellhouser, H.N., USNRDL Trip Report 3-933, HNW:jmb-12, 24 May 1954. UNCLASSIFIED.
17. Schmidt, A.C. and Wiltshire, L.I., A Constant Flow Suction Unit for Aerosol Sampling Work, American Industrial Hygiene Association Quarterly 16:2 June 1955. UNCLASSIFIED.
18. Holt, P.F., Metallurgia, 45: 156-7. UNCLASSIFIED.
19. Hemeon, W.C.L., Haines, G.F., Jr., The Magnitude of Errors in Stack Dust Sampling, advance copy for presentation at the Semi-annual Meeting of the American Society for Mechanical Engineers in Pittsburgh, Pa., June 22, 1954. UNCLASSIFIED.
20. Davies, C.N. The Sedimentation of Small Suspended Particles, Symposium on Particle Size Analysis, February 4, 1947, the Institute of Chemical Engineers and Society of Chemical Industry (Road and Building Material Group). UNCLASSIFIED.
21. Storm, Ellery, The Response of Sensitive 552 DuPont Film to Beta Radiation, Los Alamos Scientific Laboratory Report, LA-1284, 13 August 1953. UNCLASSIFIED.
22. Storm, Ellery, The Response of Film to X-radiation of Energy Up to 10 Mev, Los Alamos Scientific Laboratory Report, LA-1220, 22 March 1951. UNCLASSIFIED.
23. Finney, D.J. Probit Analyses. The MacMillan Company, New York. 1947. UNCLASSIFIED.
24. Grubb, F. E., and Weaver, C.L., The Best Unbiased Estimates of Population Standard Deviation Based on Group Ranges. Journal of the American Statistical Association. June 1947. UNCLASSIFIED.
25. Johnston, N.L., Wallace, N.R., and Zaccor, J.V., A Study of Commercial Filter Papers for Application to a Continuous Air Sampler - USNRDL - TM-14, 27 October 1954. UNCLASSIFIED.
26. Engquist, E.H. and Goodale, T.C., Cloud Phenomena: Study of Particulate and Gaseous Matter, Greenhouse Project 6.1 (Annex 6.1) Report WT-72. UNCLASSIFIED.



27. Poppoff, I.G., et al, Fallout Particle Studies - Final Report Project 2.5a, Operation Jangle, WT-395 (in WT-371). UNCLASSIFIED.
28. Lamb, W.R., "Evaluation of the AN/PDR-T1B Gamma Survey Meter". USNRDL IER-6, 5 October 1951. UNCLASSIFIED.
29. Reardon, D.E., et al, "Evaluation of the AN/PDR-18A Radiac". USNRDL IER-22, 15 October 1953. UNCLASSIFIED.
30. Joseph, W.F. and Bond, R.M "Gamma Discriminating Beta Meter". 1955. UNCLASSIFIED.
31. Morrison, P. Project Handbook, Chapter 5. Clinton Laboratory Report, CL-697.

461-462

CONFIDENTIAL