

UNCLASSIFIED

AD NUMBER

AD322378

CLASSIFICATION CHANGES

TO: unclassified

FROM: confidential

LIMITATION CHANGES

TO:
Approved for public release, distribution unlimited

FROM:
Controlling DoD Organization: Director,
Naval Research Laboratory, Washington, DC
20375.

AUTHORITY

NRL Code/5309 memo dtd 20 Feb 1997; NRL
Code/5309 memo dtd 20 Feb 1997

THIS PAGE IS UNCLASSIFIED

CONFIDENTIAL

AD 322 378

*Reproduced
by the*

ARMED SERVICES TECHNICAL INFORMATION AGENCY
ARLINGTON HALL STATION
ARLINGTON 12, VIRGINIA



CONFIDENTIAL

NOTICE: When government or other drawings, specifications or other data are used for any purpose other than in connection with a definitely related government procurement operation, the U. S. Government thereby incurs no responsibility, nor any obligation whatsoever; and the fact that the Government may have formulated, furnished, or in any way supplied the said drawings, specifications, or other data is not to be regarded by implication or otherwise as in any manner licensing the holder or any other person or corporation, or conveying any rights or permission to manufacture, use or sell any patented invention that may in any way be related thereto.

CONFIDENTIAL

NRL Report 5589

**A 100-KC QUARTZ CRYSTAL COMB
REJECTION FILTER**

[UNCLASSIFIED TITLE]

J. E. McGeogh, G. K. Jensen and C. L. Uniacke

Radar Techniques Branch
Radar Division

February 16, 1961

CATALOGED BY ASTIA
AD No. 322378



XEROX

U. S. NAVAL RESEARCH LABORATORY
Washington, D.C. STIA

CONFIDENTIAL

MAR 29 1961
14708

UNCLASSIFIED
CONFIDENTIAL
This document contains information which, if disclosed, could result in the identification of a source of information or the disclosure of a method, process, or equipment which is being developed for the defense of the United States.
Date: MAR 27 1961
By: [Signature]

CONFIDENTIAL

SECURITY

This document contains information affecting the national defense of the United States within the meaning of the Espionage Laws, Title 18, U.S.C., Sections 793 and 794. The transmission or the revelation of its contents in any manner to an unauthorized person is prohibited by law.

CONFIDENTIAL

CONTENTS

Abstract	ii
Problem Status	ii
Authorization	ii
INTRODUCTION	1
REQUIREMENTS OF THE FILTER	1
THE QUARTZ CRYSTAL NOTCH FILTER	5
THE NULL CHARACTERISTIC	6
THE BANDPASS FILTER	9
TEMPERATURE REQUIREMENTS AND CONTROL	9
CHARACTERISTIC OBTAINED WITH GATED RF INPUT	13
SUMMARY	16

ABSTRACT
[Confidential]

A comb filter that provides a high attenuation at each of 63 notch frequencies has been designed for a center frequency of 100 kc. Each tooth, or notch, is produced by a quartz crystal operating at series resonance in a bridge circuit, and the shape of the characteristic is typical of a null response. This characteristic is greatly improved by stagger tuning additional stages at each notch. The development model consists of three banks of 63 crystals each and provides 63 notches, each with a bandwidth of 1 cps at -60 db and 12 cps at -3 db. There is no insertion loss.

Great flexibility in the bandwidth and the shape of the attenuation characteristic is made possible by the use of quartz crystals. The effective Q may be either raised or lowered appreciably from the values used in the present model. The skirt factor may be improved by increasing Q and adding more stagger-tuned stages. The temperature stability is good and permits the retention of original tuning and attenuation characteristics.

Although the present model has three banks of 63 notches each, two additional banks are planned for the near future. If desired, the number of notches could be either increased or decreased to meet any change of notch-attenuation characteristic that may be desired in future operation.

PROBLEM STATUS

This is an interim report on one phase of the problem; work is continuing on this and other phases.

AUTHORIZATION

NRL Problem R02-23
Project RF 001-02-41-4007
MIPR 30-635-8-160-6136

Manuscript submitted December 2, 1960.

CONFIDENTIAL

A 100-KC QUARTZ CRYSTAL COMB REJECTION FILTER
[Unclassified Title]

INTRODUCTION

The present high-frequency Madre radar system utilizes a comb filter to remove the low-doppler-rate backscatter signals from the return signal. Calculations of the backscatter signal levels that will be received when the Madre radar high-power transmitter is placed in operation indicated that a better comb filter would be required than that now used in the system. The concept of the comb filter described in this report was originated to solve this anticipated filter problem.

The nature of the backscatter return has been previously investigated at several frequencies. Some of the results have been published.* The completed model of the comb filter has been designed to provide the characteristics that now appear most desirable, but the design permits readjustment of bandwidths and attenuation to meet the conditions that may be experimentally determined when the high-power facility becomes operative. Photographs of the completed model are shown in Figs. 1 to 3.

REQUIREMENTS OF THE FILTER

The comb filter is designed to remove the backscatter components while retaining the doppler frequencies present in the return signal of a pulsed radar. Previous work concerning the bandwidth of backscatter returns* shows that the normal backscatter bandwidth is only a few cycles. Thus, it is desired that all frequencies corresponding to very low doppler rates down to a zero-frequency doppler be attenuated greatly and that all frequencies that possess significantly high doppler frequencies, representing targets of interest, be passed.

The frequency spectrum of the transmitted rf pulse consists of a carrier component plus a number of sideband components separated by the prf of 180 cps, so the filtering operation must be performed at each of the spectral components. In the present application, the transmitter pulse shape is adequately defined by a pass bandwidth of 4 kc, or ± 2 kc about the carrier frequency. There are 22 sidebands plus the carrier component within this bandwidth. Beyond 2 kc from the carrier, the components do not contribute materially to the apparent pulse shape, and they may be low in amplitude, but they are not sufficiently low to allow them to pass without attenuation. For this reason a bandpass filter has been added to the input and to the output of each comb filter. These filters are actually double-tuned transformers transitionally coupled with the Q values adjusted for a 4-kc total bandwidth. The skirt of the attenuation curve of the bandpass filter is such that a number of sideband frequencies exist in the region between its cutoff frequency and that point at which attenuation is considered to be adequate. Additional attenuation notches are provided in this region. In all, 63 attenuation notches have been provided - one at the carrier frequency and 31 on each side of the carrier frequency. Table 1 is a list of the notch frequencies and also the crystal series-resonant frequency. The position column indicates the mechanical location of each crystal in the comb filter.

*G. K. Jensen and C. L. Uniacke, "Spectral Bandwidth of Backscatter Signals," NRL Report 4976 (Unclassified), Aug. 21, 1957.

CONFIDENTIAL

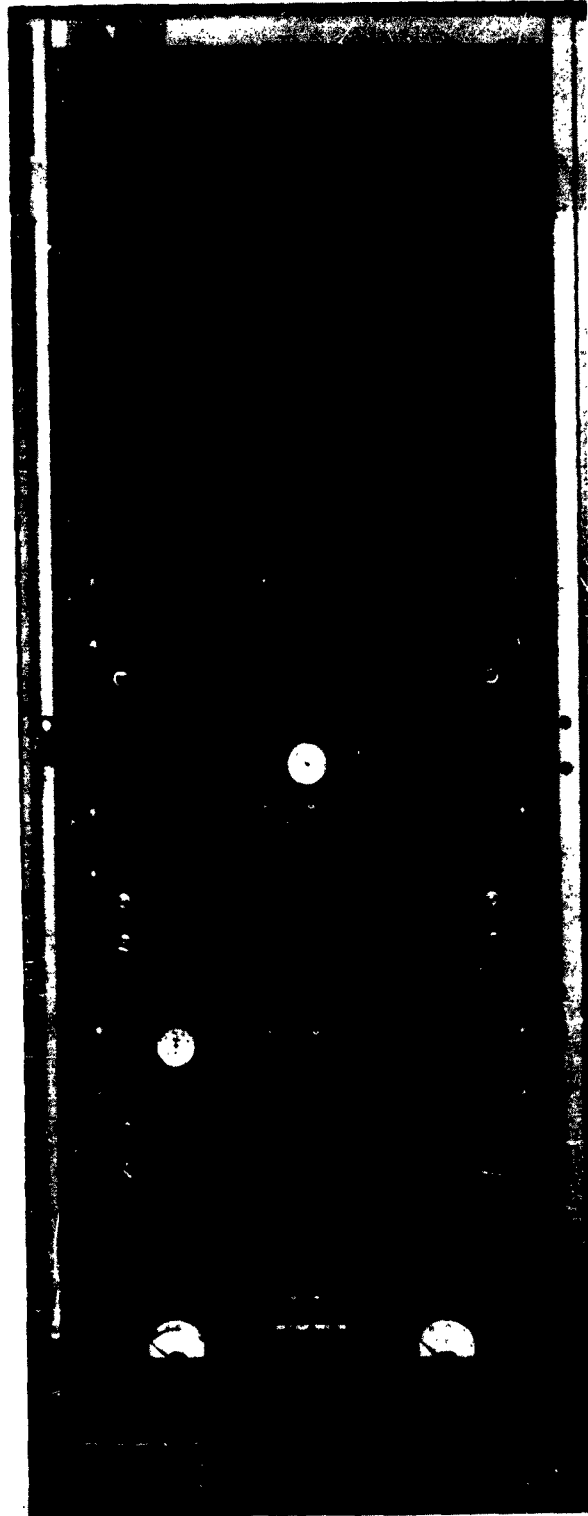

Fig. 1 - Rack front panel of three-bank,
63-tooth comb filter

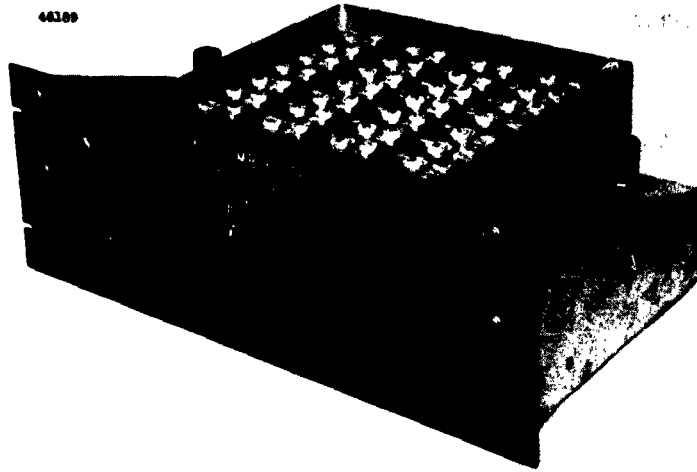

Fig. 2 - Single bank, cover removed, trimmers shown

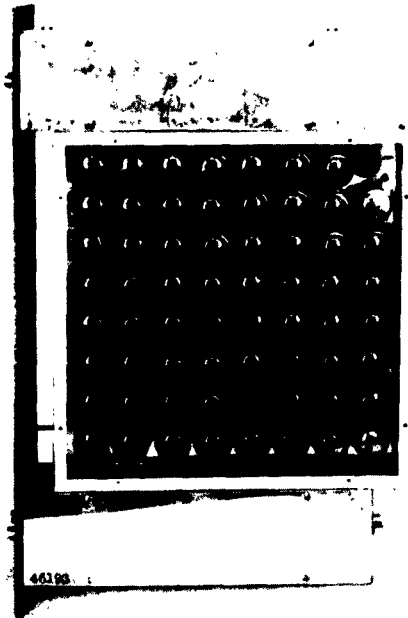

Fig. 3 - Single bank, cover removed, crystals shown

Table 1
100-KC Crystal Comb Filter

Number	Position	Tooth Freq. (kc)	Crystal Freq. (kc)	Number	Position	Tooth Freq. (kc)	Crystal Freq. (kc)
1	1B	94.420	94.395	32	5A	100.000	99.975
2	1C	94.600	94.575	33	5B	100.180	100.155
3	1D	94.780	94.755	34	5C	100.360	100.335
4	1E	94.960	94.935	35	5D	100.540	100.515
5	1F	95.140	95.115	36	5E	100.720	100.695
6	1G	95.320	95.295	37	5F	100.900	100.875
7	1H	95.500	95.475	38	5G	101.080	101.055
				39	5H	101.260	101.235
8	2A	95.680	95.655	40	6A	101.440	101.415
9	2B	95.860	95.835	41	6B	101.620	101.595
10	2C	96.040	96.015	42	6C	101.800	101.775
11	2D	96.220	96.195	43	6D	101.980	101.955
12	2E	96.400	96.375	44	6E	102.160	102.135
13	2F	96.580	96.555	45	6F	102.340	102.315
14	2G	96.760	96.735	46	6G	102.520	102.495
15	2H	96.940	96.915	47	6H	102.700	102.675
				48	7A	102.880	102.855
16	3A	97.120	97.095	49	7B	103.060	103.035
17	3B	97.300	97.275	50	7C	103.240	103.215
18	3C	97.480	97.455	51	7D	103.420	103.395
19	3D	97.660	97.635	52	7E	103.600	103.575
20	3E	97.840	97.815	53	7F	103.780	103.755
21	3F	98.020	97.995	54	7G	103.960	103.935
22	3G	98.200	98.175	55	7H	104.140	104.115
23	3H	98.380	98.355				
				56	8A	104.320	104.295
24	4A	98.560	98.535	57	8B	104.500	104.475
25	4B	98.740	98.715	58	8C	104.680	104.655
26	4C	98.920	98.895	59	8D	104.860	104.835
27	4D	99.100	99.075	60	8E	105.040	105.015
28	4E	99.280	99.255	61	8F	105.220	105.195
29	4F	99.460	99.435	62	8G	105.400	105.375
30	4G	99.640	99.615	63	8H	105.580	105.555
31	4H	99.820	99.795				

The comb filter has been designed to operate at an intermediate frequency of 100 kc. At this frequency high-quality quartz crystals are available which have very high values of Q and good temperature stability. The operating frequency is sufficiently low that the stray capacitance is not as troublesome as it would be at higher frequencies. An operating frequency of 500 kc is possible and was considered. However, at 500 kc the in-circuit value of Q must be higher by a factor of five than for the corresponding bandwidths at 100 kc. Similarly, the frequency drift expressed in ppm or in percent must be less by a factor of five for 500 kc as compared with 100-kc operation.

THE QUARTZ CRYSTAL NOTCH FILTER

Each attenuation notch is produced by a quartz crystal operating at series resonance in a bridge circuit, as shown in the simplified schematic diagram of Fig. 4. The input signal is converted to a balanced voltage in an inverter stage, so that the inputs at points A and B are equal but of opposite polarity. When the impedance of the crystal arm AC is made equal to the impedance of the balance arm BC, the voltage across the output will be zero. At series resonance the crystal-arm impedance may be represented by its series resistance of approximately 100 ohms shunted by the crystal-holder capacity of about $15 \mu\text{mf}$, and arm BC may be adjusted for the same value by balancing for a null. If the inverter driving impedance is kept low, the resultant Q is far higher than necessary. However, this capability to adjust Q is desirable, so that the value of Q may be set to a predetermined value by the addition of series resistance. When resistance is added in one arm, it must be balanced by an equivalent change in the opposite arm to obtain a null. The Q is determined by the total series resistance, which includes both.

Fig. 4 - Simplified schematic of crystal bridge circuit for attenuation characteristic

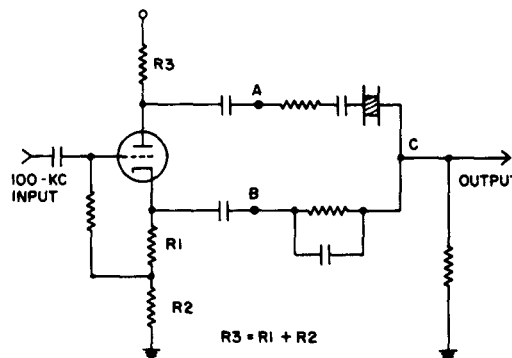

Multiple notches are obtained by operating parallel crystal arms against a single balance arm. Each notch acts independently of others, since the spacing between notches is great compared with the width of each notch. An increase in the capacity of the balance-arm impedance is required as additional crystal arms are added. Since only one balance arm is used, individual notch tuning must be accomplished in each crystal arm. In the circuit of Fig. 5, it may be noticed that trimming of both resistance and capacity may be done. Any variation in crystal Q values is balanced out by the trimmer resistance, which is many times larger than the series resistance of most crystal units and somewhat larger than the series resistance of the crystal unit that has the lowest usable Q . The trimmer capacity permits adjustment of the null frequency. All crystals, each with a series resonance 25 cps below its operating frequency, are normally operated with approximately $100 \mu\text{mf}$ of series trimmer capacity. The frequency may then be adjusted a slight amount either higher or lower than this frequency as desired, as in the case of stagger tuning of several stages about each notch frequency.

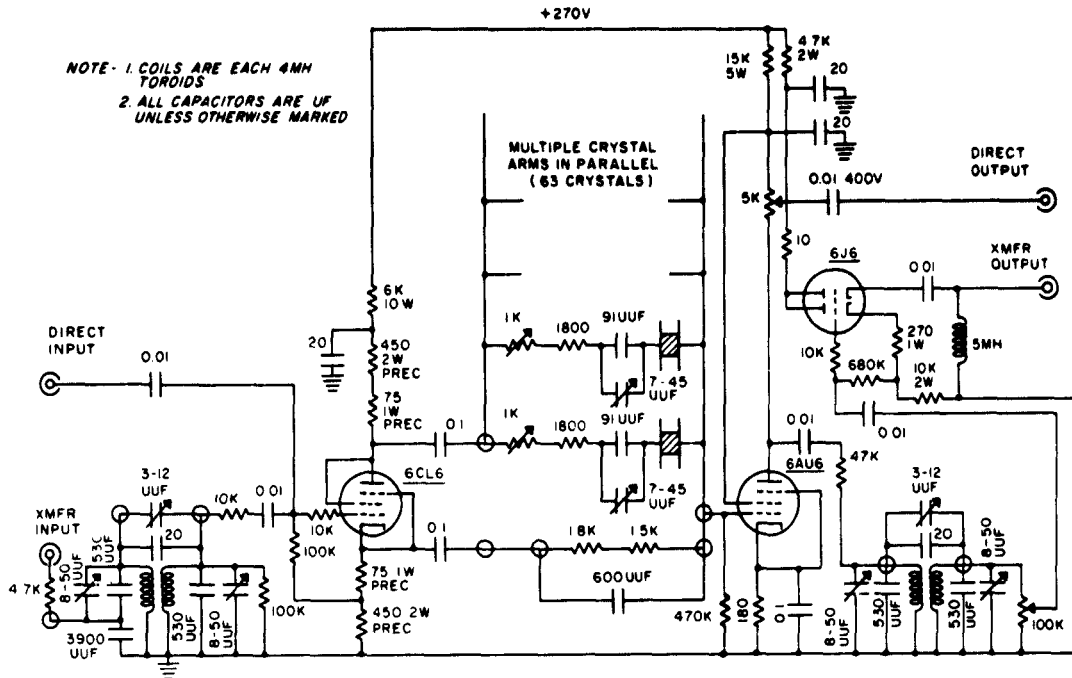

Fig. 5 - Schematic diagram of one bank of 100-kc crystal comb filter

THE NULL CHARACTERISTIC

A typical null characteristic of a single notch of the 63-notch comb filter is shown in the measured curve of Fig. 6 for the indicated series resistance. This curve is approximately 6 cps wide at the 3-db points and is shown as 45 db at the center frequency. Actually the null is much deeper, as was later determined with refined instrumentation, and the 45-db limit was that of the test generator in this case. The null width may be made wider or narrower than this curve by adjustment of effective Q, but the curve shown was used to predict graphically the attenuation characteristic that could be obtained by stagger tuning three such stages. The resultant is the outer curve of Fig. 6. Staggering the three sections by 0.5 cps produces an overall curve that is 16 cps wide at 3 db and remains at least 1 cps wide down to approximately 70 db. It should also be possible to use four stages of the same original single null characteristic staggered 0.5 cps to produce the characteristic shown in Fig. 7. This provides a wider bandwidth at the 70-db point, which is about 1.8 cps in width. An improvement could be realized here by increasing Q, but the three-stage unit appeared adequate.

A measured characteristic of the center notch of the three-stage, stagger-tuned comb filter is shown in Fig. 8. The resultant characteristic is quite close to the predicted curve. Another measured characteristic was obtained for a notch near the edge of the ± 2 -kc pass band at a notch center frequency of 101.980 kc. This also resulted as anticipated and is shown in Fig. 9.

It has been possible to make each of the notches symmetrical, and when one is made symmetrical all in that bank of 63 notches are also symmetrical. The center-notch (100 kc) crystal trimmer was adjusted in steps, and at each setting the balance arm was readjusted for a null; the output amplitude of the notch was then measured at +10 cps and -10 cps from

Fig. 6 - Single null characteristic and predicted three-section bank characteristic

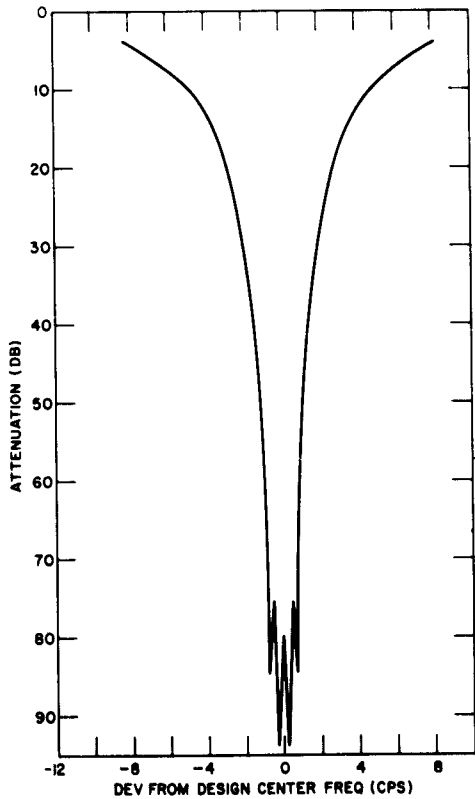
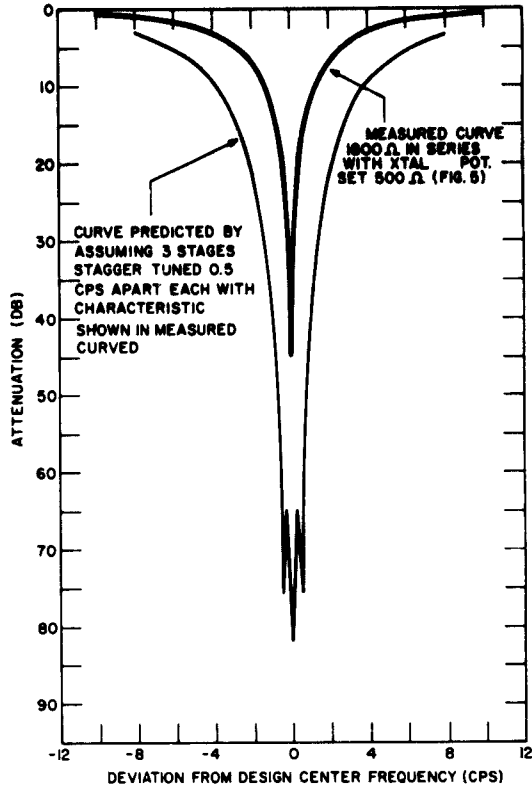

Fig. 7 - Predicted four-bank characteristic

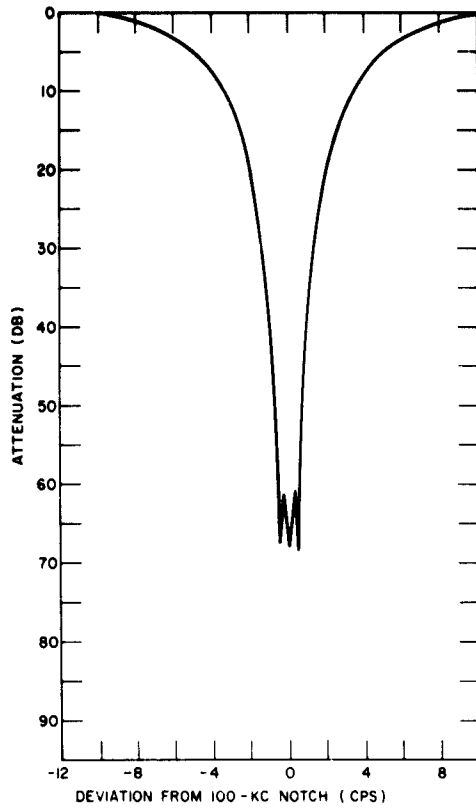
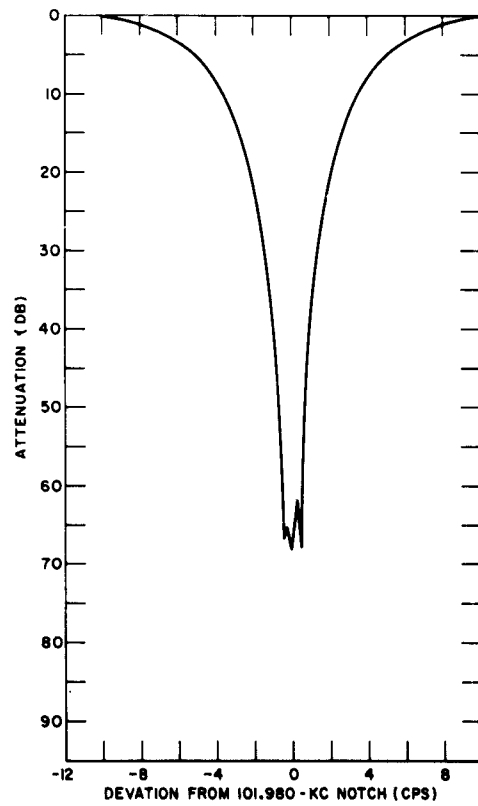

Fig. 8 - Measured three-bank, center-notch response for cw input

Fig. 9 - Measured three-bank, single-notch response at 101.980 kc for cw input



100 kc. The curve of Fig. 10 resulted, and it may be seen that there is just one setting of tuning at which the curve is balanced at the ± 10 -cps points. It should be noted that when a symmetrical curve was obtained for one notch, it was similarly symmetrical at all other notches. It is also true that at balance for each notch the Q values are all essentially identical and that all notch widths are equal.

Fig. 10 - Notch symmetry vs crystal tuning

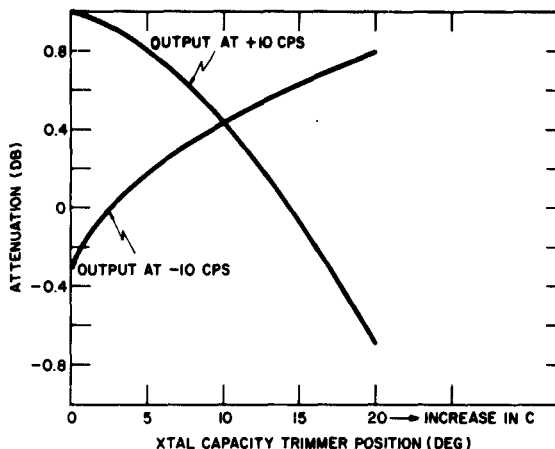

THE BANDPASS FILTER

A double-tuned transformer transitionally coupled has been used as a bandpass filter at both the input and the output of each 63-notch bank of crystals. The circuit is wired so that the transformers may be bypassed if desired merely by connecting to alternate BNC coaxial connectors at the input and output (Fig. 5).

The transformer consists of two toroids, 4 mh each, with the desired mutual coupling supplied by capacitors. It was expected that three banks of comb filters would be used, each with two bandpass filters, so the ± 2 -kc points of each transformer were adjusted to be down only 0.5 db, to produce a total attenuation for six transformers of 3 db at ± 2 kc. A curve of a single transformer is shown in Fig. 11.

TEMPERATURE REQUIREMENTS AND CONTROL

The choice of a quartz crystal for this precise filtering was logical because of its high Q values and excellent inherent frequency stability with temperature changes. The frequency of each notch is adjusted precisely. Stagger tuning is 0.5 cps at a 100-kc center frequency, and a change of 0.1 cps causes an obvious alteration of the overall curve. Hence, the maximum allowable frequency drift due to all causes should be held to within ± 0.05 cps, which is ± 0.5 ppm for the full operating temperature range.

The particular crystal chosen for use in the comb filter is an MT-cut high-Q unit mounted in an evacuated glass bulb with octal tube base. This comprises the G-9 holder, manufactured by the James Knights Company. Originally a 100-kc $+5^\circ$ X-cut crystal in the H-17 mount was considered because of its convenient small size, but several limitations prevented its use. A notch test circuit was constructed and the crystal characteristics

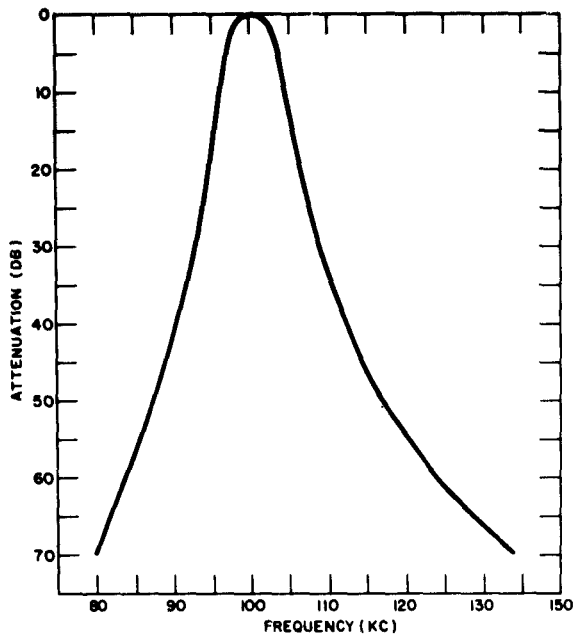

Fig. 11 - Double-tuned transformer frequency response

determined. First, the narrowest 3-db notch bandwidth of several samples measured approximately 11.5 to 12 cps. The value presently used in the circuit is adjusted to 6 cps, and with some refinement of the driving stage the bandwidth may have been made barely acceptable for the H-17 type crystal. The G-9 crystal in the same circuit, however, has a notch width of about 1 cps. Second, the change of notch frequency vs input signal level for the crystal in an H-17 holder was measured, and the result is shown in Fig. 12. This may be compared with Fig. 13, which shows results of a similar test with the G-9 crystal unit. When no resistance is added in series with the crystal, the effect of input signal upon tuning is greater than when a series resistance is added, as may be seen from Fig. 13. In the final circuit the series resistance with the G-9 crystal was 2300 ohms, making the detuning effect negligible. In the case of the H-17 crystal unit, if operating at or near maximum Q, there would be little or no added series resistance, and the detuning effect would be large. It should be noted that these measurements were made with a cw input signal. When the normal pulsed rf signal is used, the power is distributed among all sidebands and is not concentrated at one frequency. This distribution of power, which allows operation of the comb filter at higher levels, is a highly desirable feature. Third, the MT-cut crystal possesses a much better frequency stability than the +5° X cut, but unfortunately it does not fit in the H-17 holder for a 100-kc unit; thus a larger mounting area is required.

The temperature characteristics of a large number of G-9 units have been measured. Typical characteristics for two of these crystal units are shown in Fig. 14. The curve is very broad, in contrast to a typical curve for a 5° X cut, which would have been required to fit into an H-17 holder. The temperature characteristic of the crystal mounted in the H-17 holder is not shown here. Crystals were ordered in the G-9 mount with a zero temperature coefficient at +35° C. It was anticipated from curves that a very coarse control of temperature would prove adequate to maintain the desired stability. However,

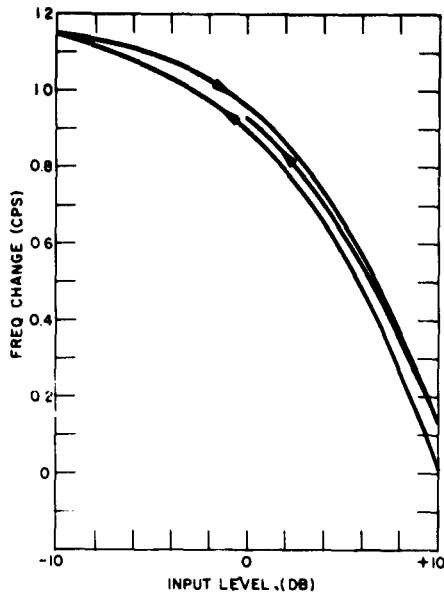

Fig. 12 - Crystal-frequency change vs input level for H-17 crystal unit

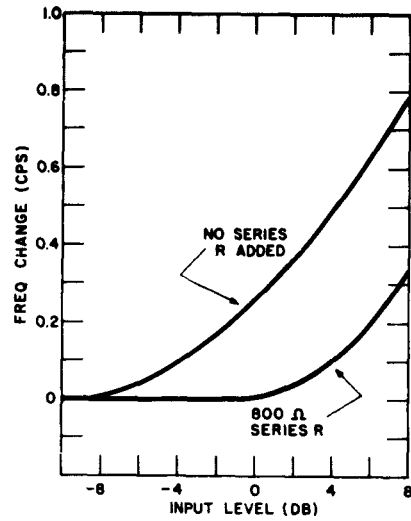

Fig. 13 - Crystal-frequency change vs input level for G-9 crystal unit

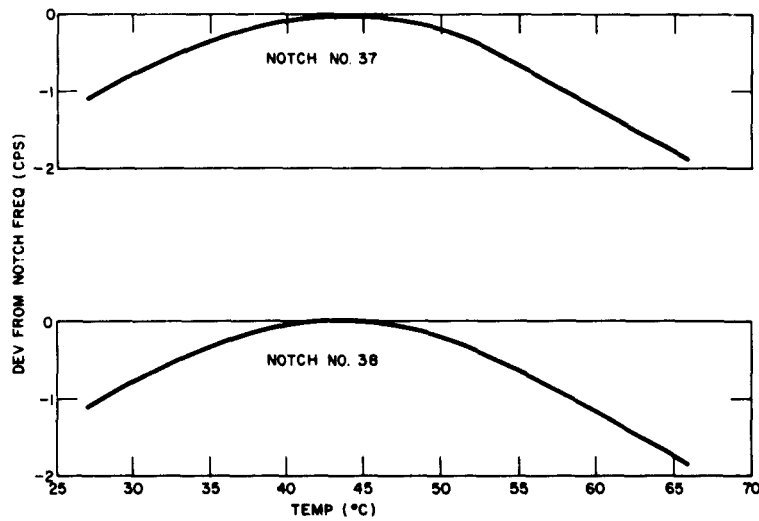

Fig. 14 - Crystal-frequency change vs temperature for two typical units

measurements of the received crystal units showed appreciable differences in temperature at the point of reversal of the temperature coefficient for a number of samples and were actually found to vary from $+35^{\circ}\text{C}$ to $+50^{\circ}\text{C}$. Most were centered at $+42^{\circ}\text{C}$, instead of $+35^{\circ}\text{C}$, as ordered.

Because of the wide differences in optimum operating temperatures, a more precise method of temperature control was constructed. The crystals and associated tuning and balancing components were located in a chassis by themselves with cover plate top and bottom. The inverter, amplifier, and cathode follower were mounted on two separate chassis connected to the two sides of the crystal unit. The entire assembly was connected to a standard rack panel but spaced back from the panel to provide for the flow of air. Each of the banks of the comb filter was similarly mounted. In the bottom rack is the power supply, but behind it is a blower for the forced circulation of air. Two cone heater elements operated in series are controlled by a thermostat with a small temperature differential and set to 42°C . These are located just above and on either side of the blower. A second thermostat of wider temperature differential and snap action was connected in series with the heater units and set for approximately 50°C to act as a safety unit and to prevent damage in case of the failure of the original thermostat.

The results of the temperature-controlled operation are shown in Figs. 15 and 16. The temperature of the crystal compartment vs warmup time is shown in Fig. 15, and the warmup frequency drift of three of the crystal notches is also shown vs warmup time. All of the notches were within 0.1 cps of their desired frequency in 100 minutes and within 0.05 cps in 120 minutes. The notches shown are the center frequency and the ones nearest the ± 2 -kc band limit. Figure 16 shows the temperature of the circulated air in addition to a recheck of crystal-compartment warmup and the center-frequency notch warmup. The thermal lag in crystal-compartment temperature from the circulated air temperature is long compared with the time of each off-on heater cycle, so very little variation occurs. Since the crystals are mounted in an evacuated envelope, there is an additional lag between the crystal-compartment temperature and the temperature of the crystal itself. The temperature-control characteristics are highly satisfactory for the intended purpose.

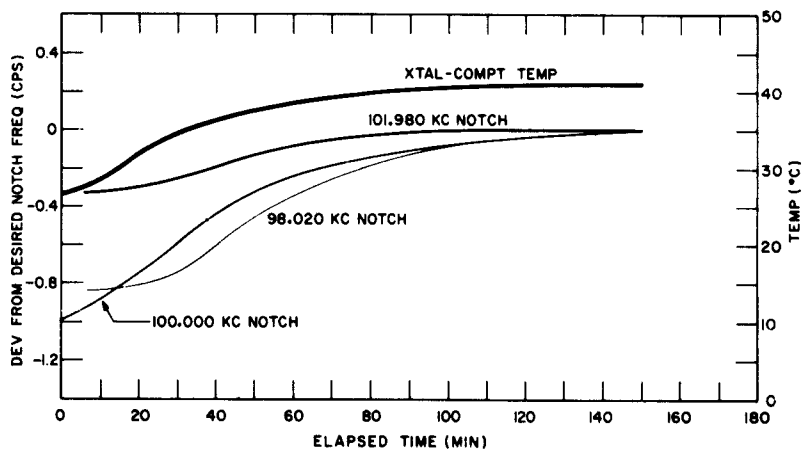

Fig. 15 - Notch frequency and crystal-compartment temperature vs warmup time

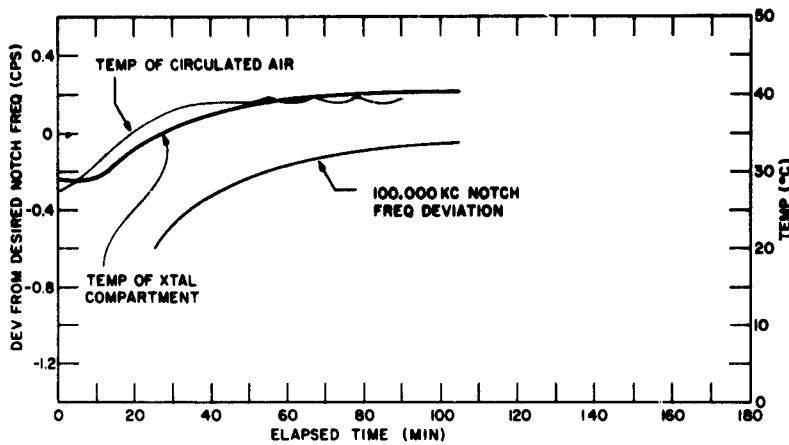

Fig. 16 - Notch frequency and temperature of air circulated in rack vs warmup time

CHARACTERISTIC OBTAINED WITH GATED RF INPUT

Previous measurements of the comb filter have been made by using a sine-wave input and determining the output for one frequency at a time. The characteristics of all notches must be determined to predict the overall characteristic, and even then there is some doubt as to the way in which components will add. The overall spectral response may readily be determined with one characteristic curve by utilizing a gated rf signal input. This method is a more accurate representation of performance under actual operating conditions, but much care must be exercised in setting up the instrumentation for the measurement. The block diagram of this instrumentation is shown in Fig. 17.

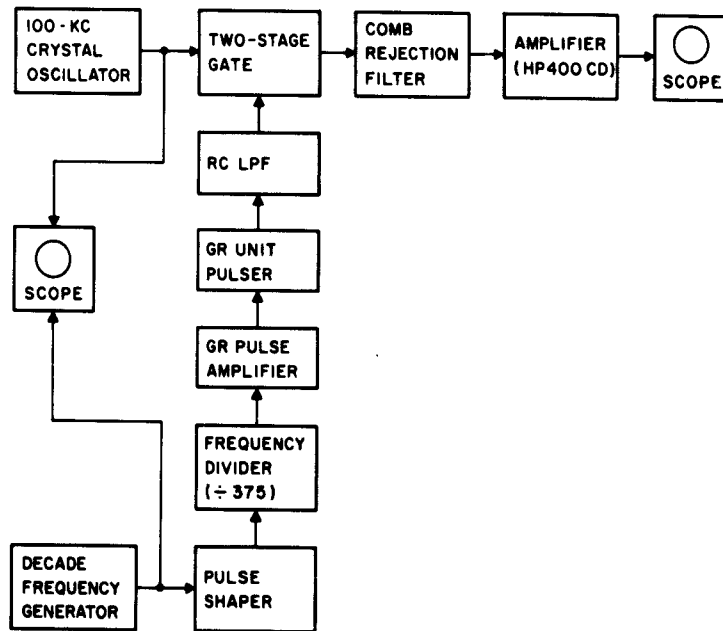

Fig. 17 - Block diagram of instrumentation for determining overall three-bank filter response to a pulsed rf input signal

A precise 100-kc signal is gated by a shaped pulse at exactly 180 cps and fed to the comb filter. The output of the comb is measured by a suitable voltmeter and an oscilloscope as the 100-kc signal is tuned through the attenuation band of about ± 10 cycles from 100 kc. The rf signal is derived from a crystal oscillator that has a very low level of spurious-frequency output, is very stable, and possesses a capacitive trimmer for providing a limited variation of frequency. Its precise frequency is determined to within 0.01 cps (within 0.1 parts per million) by comparing its output with a decade frequency generator on a 1:1 Lissajous pattern. The 180-cps gating signal must also be precise if the spectral lines are to fall within all the notches. Since there are 31 notches to each side of the carrier, any shift in frequency from 180 cps will produce a shift of 31 times that frequency shift at the 31st notch. If measurement is to be made within ± 0.1 cps, the 180-cps generator must not deviate more than $\pm (0.1/31) = \pm 0.003$ cps. This is an accuracy of ± 16 ppm. Any jitter present on the 180-cps signal will be slope detected by the comb filter and will produce an output. Many types of audio oscillators were examined but were found not suitable for this application due to jitter or drift rate. The decade generator was used at a frequency of 67,500 cps, fed to a pulse shaper, and then divided by 375. This circuit was a conveniently available binary-type frequency divider which determined the input frequency setting required to obtain exactly 180-cps output. This 180-cps output contained no measurable jitter and was suitable for keying the GR Unit Pulser, whose output was fed to the gate chassis.

The schematic diagram of the two-stage gate chassis is shown in Fig. 18. The gating signal is applied to the input of an inverter which back biases two associated diodes and presents a high impedance to ground at the junction of the diodes for the duration of the gating pulse. The rf input is fed to the same point through a 15-k resistance. When the diodes are conducting, as is the case between gating pulses, the attenuation of the rf signal may be expected to be in excess of 30 db. During the gating pulse, the attenuation is very slight, so the ratio of the pulse level to residual base-line level is in excess of 30 db. The stages of gating are cascaded, and a ratio greater than 60 db is obtained. A cathode follower is used at the output of each stage.

The carrier frequency of 100 kc is not an exact multiple of 180 cps. The harmonics of 180 cps of greatest interest are:

555th harmonic = 99, 900 cps

556th harmonic = 100,080 cps

557th harmonic = 100,260 cps

When the rf pulse is viewed on a scope triggered with an external 180 cps, the individual rf cycles appear to be sliding across the burst period. This pattern may be stopped by offsetting the 180 cps enough to cause the 556th harmonic to occur at 100,090 cps, which is midway between notch frequencies; then a stopped double trace occurs, one of reversed polarity. A single trace may be viewed when the scope triggers at a 90-cps rate; then the second burst that may be viewed will begin with the opposite polarity from the first. The change necessary in the 180 cps to produce a 10-cps change at the 556th harmonic also produces a change of $31/556 \times 10 = 0.558$ cps at the 31st sideband of 100 kc. This is the absolute maximum permissible shift that can occur before the sideband frequency would occur out of the null region of the notch.

The gating pulse derived from the General Radio Unit Pulser was a rectangular wave shape. The slight unbalance in the gate within the fast rise and fall periods of the pulse caused spikes in the output even when the rf input was removed. The level of each of these signals at the 555th, 556th, and 557th harmonics was measured by means of precise crystal

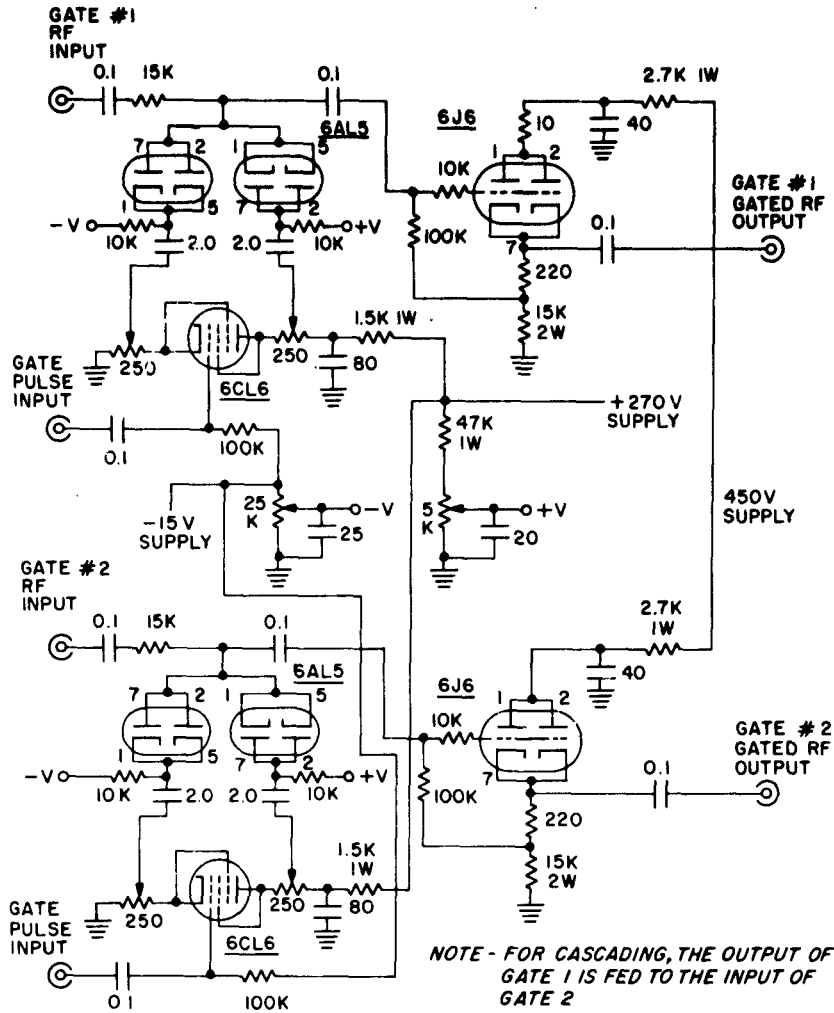

Fig. 18 - Schematic diagram of two-stage gate

filters to be -48 db with respect to the carrier level. Since these fall midway between notches of the comb filter, they will not be attenuated, and a residual level of 48 db is measured. The amplitude of the harmonic output of the 180-cps gating pulse is materially reduced by feeding the gating pulse through a low-pass RC filter prior to the gate. A series resistance of 9 k and a shunt capacitance of 0.0027 microfarad reduced the harmonic level below 60 db.

An overall selectivity curve of the composite three-stage comb filter for a gated rf input pulse is shown on Fig. 19. It will be noted that this curve is identical with the single-notch curves measured with a cw signal.

The problem of the harmonics of 180 cps may be solved if necessary by retuning all notches of the comb for a prf of $10^6 / 556 = 179.8$ and operating the system at this new prf. This would place the harmonics of the prf exactly in the notches. However, the problem of the harmonics of 180 cps is a deficiency of the test generator and not of the comb filter.

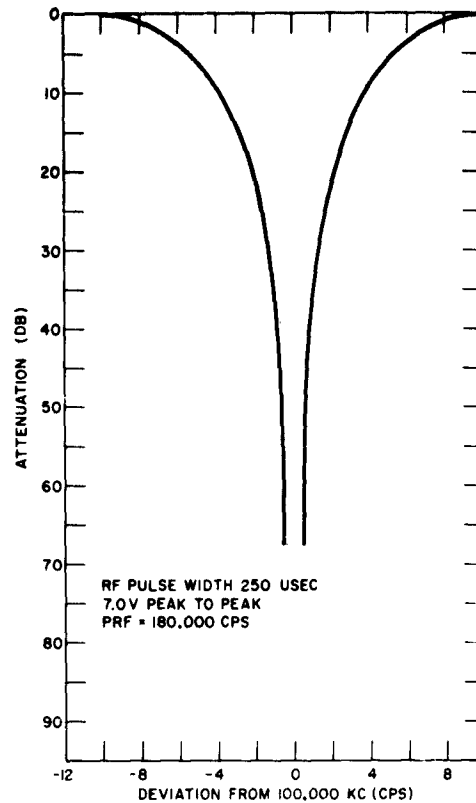

Fig. 19 - Overall three-bank filter response to a pulsed rf input signal

The voltage measurements have been made by scope rather than by ac voltmeter. This is because the duty cycle of the signal is such that overloading occurs in the amplifier of the ac voltmeter before a significant meter deflection is available.

SUMMARY

A 100-kc quartz crystal comb rejection filter has been successfully completed and is in current use in the Madre radar system. The purpose of the filter is to remove the carrier and the sideband components from the pulse-radar return signal that are due to fixed targets, or backscatter, and to retain the radar-return information for targets with significant doppler rates. The filter consists of three banks of 63 quartz crystals per bank. Each bank has a rejection notch at the carrier frequency and 31 additional notches on each side of the carrier, spaced by the prf of the system. The entire unit, with power supply and temperature control, is housed in a rack which matches the other units in the Madre system.

The following filtering characteristics are provided:

1. A rejection bandwidth of at least 1 cps at 60 db attenuation for each tooth of the rejection comb.

2. A rejection bandwidth of 12 cps at 3 db attenuation for each tooth.
3. No insertion loss at frequencies between the teeth.

The shape of the attenuation curve is obtained by stagger tuning at each notch frequency. In the completed unit, staggering of 0.5 cps is used.

The use of quartz crystals offers several advantages over other components.

1. The Q is sufficiently high, usually above 10^5 , so that each notch width may be made as narrow as desired.
2. The Q values may be adjusted to be equal, so that all notches have identical attenuation characteristics.
3. The frequency stability is inherently very good. This permits the use of more stagger-tuned stages of narrower bandwidths and smaller staggering offsets, to obtain desired overall response characteristics.

* * *

<p style="text-align: center;">CONFIDENTIAL</p> <p>Naval Research Laboratory. Report 5589 [CONF.] A 100-KC QUARTZ CRYSTAL COMB REJECTION FILTER [Unclassified Title], by J. E. McGeogh, G. K. Jensen, and C. L. Uniacke, 17 pp. & figs., February 16, 1961.</p> <p>A comb filter that provides a high attenuation at each of 63 notch frequencies has been designed for a center frequency of 100 kc. Each tooth, or notch, is produced by a quartz crystal operating at series resonance in a bridge circuit, and the shape of the characteristic is typical of a null response. This characteristic is greatly improved by stagger tuning additional stages at each notch. The development</p> <p style="text-align: right;">CONFIDENTIAL (over)</p>	<p style="text-align: center;">CONFIDENTIAL</p> <p>Naval Research Laboratory. Report 5589 [CONF.] A 100-KC QUARTZ CRYSTAL COMB REJECTION FILTER [Unclassified Title], by J. E. McGeogh, G. K. Jensen, and C. L. Uniacke, 17 pp. & figs., February 16, 1961.</p> <p>A comb filter that provides a high attenuation at each of 63 notch frequencies has been designed for a center frequency of 100 kc. Each tooth, or notch, is produced by a quartz crystal operating at series resonance in a bridge circuit, and the shape of the characteristic is typical of a null response. This characteristic is greatly improved by stagger tuning additional stages at each notch. The development</p> <p style="text-align: right;">CONFIDENTIAL (over)</p>	<p style="text-align: center;">CONFIDENTIAL</p> <p>Naval Research Laboratory. Report 5589 [CONF.] A 100-KC QUARTZ CRYSTAL COMB REJECTION FILTER [Unclassified Title], by J. E. McGeogh, G. K. Jensen, and C. L. Uniacke, 17 pp. & figs., February 16, 1961.</p> <p>A comb filter that provides a high attenuation at each of 63 notch frequencies has been designed for a center frequency of 100 kc. Each tooth, or notch, is produced by a quartz crystal operating at series resonance in a bridge circuit, and the shape of the characteristic is typical of a null response. This characteristic is greatly improved by stagger tuning additional stages at each notch. The development</p> <p style="text-align: right;">CONFIDENTIAL (over)</p>	<p style="text-align: center;">CONFIDENTIAL</p> <p>Naval Research Laboratory. Report 5589 [CONF.] A 100-KC QUARTZ CRYSTAL COMB REJECTION FILTER [Unclassified Title], by J. E. McGeogh, G. K. Jensen, and C. L. Uniacke, 17 pp. & figs., February 16, 1961.</p> <p>A comb filter that provides a high attenuation at each of 63 notch frequencies has been designed for a center frequency of 100 kc. Each tooth, or notch, is produced by a quartz crystal operating at series resonance in a bridge circuit, and the shape of the characteristic is typical of a null response. This characteristic is greatly improved by stagger tuning additional stages at each notch. The development</p> <p style="text-align: right;">CONFIDENTIAL (over)</p>
<p style="text-align: center;">CONFIDENTIAL</p> <p>Naval Research Laboratory. Report 5589 [CONF.] A 100-KC QUARTZ CRYSTAL COMB REJECTION FILTER [Unclassified Title], by J. E. McGeogh, G. K. Jensen, and C. L. Uniacke, 17 pp. & figs., February 16, 1961.</p> <p>A comb filter that provides a high attenuation at each of 63 notch frequencies has been designed for a center frequency of 100 kc. Each tooth, or notch, is produced by a quartz crystal operating at series resonance in a bridge circuit, and the shape of the characteristic is typical of a null response. This characteristic is greatly improved by stagger tuning additional stages at each notch. The development</p> <p style="text-align: right;">CONFIDENTIAL (over)</p>	<p style="text-align: center;">CONFIDENTIAL</p> <p>Naval Research Laboratory. Report 5589 [CONF.] A 100-KC QUARTZ CRYSTAL COMB REJECTION FILTER [Unclassified Title], by J. E. McGeogh, G. K. Jensen, and C. L. Uniacke, 17 pp. & figs., February 16, 1961.</p> <p>A comb filter that provides a high attenuation at each of 63 notch frequencies has been designed for a center frequency of 100 kc. Each tooth, or notch, is produced by a quartz crystal operating at series resonance in a bridge circuit, and the shape of the characteristic is typical of a null response. This characteristic is greatly improved by stagger tuning additional stages at each notch. The development</p> <p style="text-align: right;">CONFIDENTIAL (over)</p>	<p style="text-align: center;">CONFIDENTIAL</p> <p>Naval Research Laboratory. Report 5589 [CONF.] A 100-KC QUARTZ CRYSTAL COMB REJECTION FILTER [Unclassified Title], by J. E. McGeogh, G. K. Jensen, and C. L. Uniacke, 17 pp. & figs., February 16, 1961.</p> <p>A comb filter that provides a high attenuation at each of 63 notch frequencies has been designed for a center frequency of 100 kc. Each tooth, or notch, is produced by a quartz crystal operating at series resonance in a bridge circuit, and the shape of the characteristic is typical of a null response. This characteristic is greatly improved by stagger tuning additional stages at each notch. The development</p> <p style="text-align: right;">CONFIDENTIAL (over)</p>	<p style="text-align: center;">CONFIDENTIAL</p> <p>Naval Research Laboratory. Report 5589 [CONF.] A 100-KC QUARTZ CRYSTAL COMB REJECTION FILTER [Unclassified Title], by J. E. McGeogh, G. K. Jensen, and C. L. Uniacke, 17 pp. & figs., February 16, 1961.</p> <p>A comb filter that provides a high attenuation at each of 63 notch frequencies has been designed for a center frequency of 100 kc. Each tooth, or notch, is produced by a quartz crystal operating at series resonance in a bridge circuit, and the shape of the characteristic is typical of a null response. This characteristic is greatly improved by stagger tuning additional stages at each notch. The development</p> <p style="text-align: right;">CONFIDENTIAL (over)</p>

CONFIDENTIAL

model consists of three banks of 63 crystals each and provides 63 notches, each with a bandwidth of 1 cps at -60 db and 12 cps at -3 db. There is no insertion loss.

Great flexibility in the bandwidth and the shape of the attenuation characteristic is made possible by the use of quartz crystals. The effective Q may be either raised or lowered appreciably from the values used in the present model. The skirt factor may be improved by increasing Q and adding more stagger-tuned stages. The temperature stability is good and permits the retention of original tuning and attenuation characteristics.

Although the present model has three banks of 63 notches each, two additional banks are planned for the near future. If desired, the number of notches could be either increased or decreased to meet any change of notch-attenuation characteristic that may be desired in future operation.
[Confidential Abstract]

CONFIDENTIAL

CONFIDENTIAL

model consists of three banks of 63 crystals each and provides 63 notches, each with a bandwidth of 1 cps at -60 db and 12 cps at -3 db. There is no insertion loss.

Great flexibility in the bandwidth and the shape of the attenuation characteristic is made possible by the use of quartz crystals. The effective Q may be either raised or lowered appreciably from the values used in the present model. The skirt factor may be improved by increasing Q and adding more stagger-tuned stages. The temperature stability is good and permits the retention of original tuning and attenuation characteristics.

Although the present model has three banks of 63 notches each, two additional banks are planned for the near future. If desired, the number of notches could be either increased or decreased to meet any change of notch-attenuation characteristic that may be desired in future operation.
[Confidential Abstract]

CONFIDENTIAL

CONFIDENTIAL

model consists of three banks of 63 crystals each and provides 63 notches, each with a bandwidth of 1 cps at -60 db and 12 cps at -3 db. There is no insertion loss.

Great flexibility in the bandwidth and the shape of the attenuation characteristic is made possible by the use of quartz crystals. The effective Q may be either raised or lowered appreciably from the values used in the present model. The skirt factor may be improved by increasing Q and adding more stagger-tuned stages. The temperature stability is good and permits the retention of original tuning and attenuation characteristics.

Although the present model has three banks of 63 notches each, two additional banks are planned for the near future. If desired, the number of notches could be either increased or decreased to meet any change of notch-attenuation characteristic that may be desired in future operation.
[Confidential Abstract]

CONFIDENTIAL

CONFIDENTIAL

model consists of three banks of 63 crystals each and provides 63 notches, each with a bandwidth of 1 cps at -60 db and 12 cps at -3 db. There is no insertion loss.

Great flexibility in the bandwidth and the shape of the attenuation characteristic is made possible by the use of quartz crystals. The effective Q may be either raised or lowered appreciably from the values used in the present model. The skirt factor may be improved by increasing Q and adding more stagger-tuned stages. The temperature stability is good and permits the retention of original tuning and attenuation characteristics.

Although the present model has three banks of 63 notches each, two additional banks are planned for the near future. If desired, the number of notches could be either increased or decreased to meet any change of notch-attenuation characteristic that may be desired in future operation.
[Confidential Abstract]

CONFIDENTIAL

MEMORANDUM

20 February 1997

Subj: Document Declassification

Ref: (1) Code 5309 Memorandum of 29 Jan. 1997
(2) Distribution Statements for Technical Publications
NRL/PJ/5230-95-293

Encl: (a) Code 5309 Memorandum of 29 Jan. 1997
(b) List of old Code 5320 Reports
(c) List of old Code 5320 Memorandum Reports

1. In Enclosure (a) it was recommended that the following reports be declassified, four reports have been added to the original list:

Formal: 5589, 5811, 5824, 5825, 5849, 5862, 5875, 5881, 5903, 5962, 6015, 6079, 6148, 6198, 6272, 6371, 6476, 6479, 6485, 6507, 6508, 6568, 6590, 6611, 6731, 6866, 7044, 7051, 7059, 7350, 7428, 7500, 7638, 7655. Add 7684, 7692.

Memo: 1251, 1287, 1316, 1422, [redacted], 1500, 1527, 1537, 1540, 1567, 1637, 1647, 1727, 1758, 1787, 1789, 1790, 1811, 1817, 1823, 1885, 1939, 1981, 2135, 2624, 2701, 2645, 2721, 2722, 2723, 2766. Add 2265, 2715.

The recommended distribution statement for the these reports is: **Approved for public release; distribution is unlimited.**

2. The above reports are included in the listings of enclosures (b) and (c) and were selected because of familiarity with the contents. The rest of these documents very likely should receive the same treatment.

J. M. Headrick
J. M. Headrick
Code 5309

Copy: Code 1221 — *CR OK 7/1/97*
Code 5300
Code 5320
Code 5324