

UNCLASSIFIED

92077

Armed Services Technical Information Agency

Reproduced by

DOCUMENT SERVICE CENTER

KNOTT BUILDING, DAYTON, 2, OHIO

This document is the property of the United States Government. It is furnished for the duration of the contract and shall be returned when no longer required, or upon recall by ASTIA to the following address: Armed Services Technical Information Agency, Document Service Center, Knott Building, Dayton 2, Ohio.

NOTICE: WHEN GOVERNMENT OR OTHER DRAWINGS, SPECIFICATIONS OR OTHER DATA ARE USED FOR ANY PURPOSE OTHER THAN IN CONNECTION WITH A DEFINITELY RELATED GOVERNMENT PROCUREMENT OPERATION, THE U. S. GOVERNMENT THEREBY INCURS NO RESPONSIBILITY, NOR ANY OBLIGATION WHATSOEVER; AND THE FACT THAT THE GOVERNMENT MAY HAVE FORMULATED, FURNISHED, OR IN ANY WAY SUPPLIED THE SAID DRAWINGS, SPECIFICATIONS, OR OTHER DATA IS NOT TO BE REGARDED BY IMPLICATION OR OTHERWISE AS IN ANY MANNER LICENSING THE HOLDER OR ANY OTHER PERSON OR CORPORATION, OR CONVEYING ANY RIGHTS OR PERMISSION TO MANUFACTURE, USE OR SELL ANY PATENTED INVENTION THAT MAY IN ANY WAY BE RELATED THERETO.

UNCLASSIFIED

FLORIDA STATE UNIVERSITY
DEPARTMENT OF METEOROLOGY



TECHNICAL REPORT NO. 7

A Simple Analog Computer for Determination of the Laplacian

of a Mapped Quantity

By *Seymour L. Hess*



PREPARED UNDER PROJECT NR-082-071, CONTRACT NONR-1600(00)

WITH THE OFFICE OF NAVAL RESEARCH

1 MAY 1956

ABSTRACT

The determination of the Laplacian of a mapped quantity, such as the geostrophic vorticity, is an important but a time consuming process. The common procedure involves a number of interpolations and an algebraic computation for each point at which the evaluation is made. A device is presented in which the slow process of interpolation is replaced by the faster and more reliable process of measurement of distance between isopleths of the mapped quantity, and the algebraic calculation is replaced by the rapid, automatic operation of a DC analog computer. The numerical result is presented as the deflection of a millivoltmeter.

In practice the use of this computer proves to be a rapid, reproducible, sufficiently accurate means of determining the geostrophic vorticity from an analysis of the contours of an isobaric surface.

1. Introduction

The operation of determining the two-dimensional Laplacian of a mapped variable, $\nabla^2 h = \partial^2 h / \partial x^2 + \partial^2 h / \partial y^2$, where x and y are horizontal Cartesian coordinates, is a recurring problem in meteorology today. As the application of theoretical results to forecasting grows, more and more operational weather groups, as well as research groups, find that they must devote appreciable effort to the evaluation of this and other differential expressions. The outstanding example is the evaluation of the geostrophic vorticity from the contours of an analyzed isobaric chart.

The usual approach to the numerical evaluation of a differential expression is to approximate derivatives, which are ratios of infinitesimal increments, with ratios of finite increments. Thus a differential expression is reduced to an algebraic one. For example, if in fig. 1 the values of the variable h are interpolated at the five points indicated,

$$\nabla^2 h \approx \frac{h_1 + h_2 + h_3 + h_4 - 4h_5}{L^2} \quad (1)$$

where the subscript identifies the point at which a value of h is interpolated, and L is the constant finite distance separating points 1 to 4 from point 5. This technique requires several interpolations and an algebraic computation for each value of the Laplacian which is calculated. Both parts of the procedure are time consuming and subject to error; thus the process is not completely satisfactory.

One way by which an improvement might be made is to utilize a ratio of finite differences in which the increment of the variable h is kept fixed and equal to the increment between successive isopleths in a map

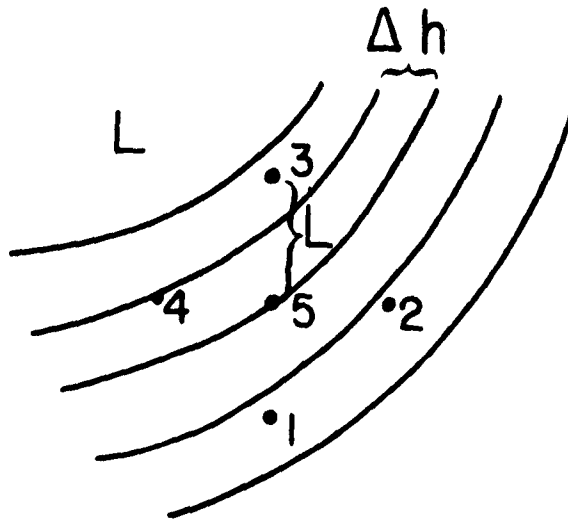

Fig. 1. A grid of four points equally spaced around a central point. Interpolated values at these five points are used to evaluate the Laplacian of the field of h by means of equation (1).

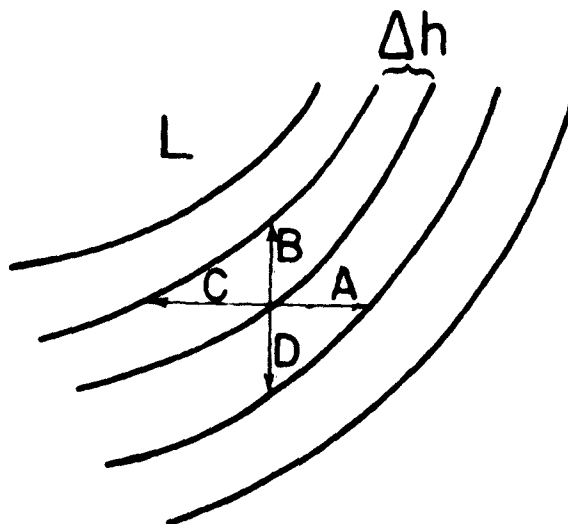

Fig. 2. Distances along orthogonal directions separating adjacent lines of the variable h . These distances can be used to determine the Laplacian of the field of h by means of equation (3).

of h . The distance between isopleths would then vary, and distance measurement would replace interpolation. In principle, one should be able to measure distances more rapidly and with fewer errors than one could make interpolations. In addition, it might be possible to gear the mechanical device which measures the distances to a simple computer which would do the algebra necessary to evaluate the Laplacian. Thus both of the cumbersome steps in the usual process could be replaced. In subsequent sections, we shall show one way in which these suggestions can be carried out.

2. A finite difference approximation to the Laplacian

In fig. 2, the orthogonal distances separating an isopleth of h from adjacent ones are labelled A , B , C , and D . If the increment in h from one isopleth to the next is the constant value Δh , approximations to the first derivatives in the x -direction are $\Delta h/A$ and $\Delta h/C$. Correspondingly the approximations to the first derivatives in the y -direction are $-\Delta h/B$ and $-\Delta h/D$. The second derivatives are approximately

$$\frac{\frac{\Delta h}{A} - \frac{\Delta h}{C}}{\frac{1}{2}(A + C)} \quad \text{and} \quad \frac{-\frac{\Delta h}{B} + \frac{\Delta h}{D}}{\frac{1}{2}(B + D)}$$

Thus,

$$\nabla^2 h \approx 2\Delta h \left[\left(\frac{1}{A} - \frac{1}{C} \right) \frac{1}{A + C} + \left(\frac{1}{D} - \frac{1}{B} \right) \frac{1}{B + D} \right]$$

or

$$\nabla^2 h \approx 2\Delta h \left[\frac{C - A}{AC(A + C)} + \frac{B - D}{BD(B + D)} \right]$$

To simplify this expression, we multiply and divide the first term in the brackets by $A + C$, and perform the same operations on the second term

with $B + D$. The result is

$$\nabla^2 h \approx 2\Delta h \left[\frac{C^2 - A^2}{AC(A + C)^2} + \frac{B^2 - D^2}{BD(B + D)^2} \right] \quad (2)$$

Now a quantity like $(A + C)^2 = 4AC + (A - C)^2$ may be approximated quite well if A and C are not greatly different. The fractional error in assuming that $(A + C)^2 = 4AC$ is $(A - C)^2 / (A + C)^2$. This error is zero when $A = C$ and is about 10 per cent when $A = 2C$. When we introduce this kind of approximation into both terms on the right of equation (2) and simplify, we get

$$\nabla^2 h \approx \frac{\Delta h}{2} \left[\frac{1}{A^2} - \frac{1}{B^2} - \frac{1}{C^2} + \frac{1}{D^2} \right] \quad (3)$$

Equation (3) involves the sum of four inverse squares, and is in a convenient form for the design of an electrical analog which can automatically perform the algebra. However, it is not the only approximation to the Laplacian which might prove useful.

When equation (3) is used to estimate the geostrophic vorticity, the approximations mean that in cases of marked shear the magnitude of the vorticity will be overestimated somewhat.

3. Theory of an electrical analog

If equation (3) is used to approximate the Laplacian, the problem can be reduced to mechanical measurement of the four distances and electrical calculation of a sum of inverse squares. The distances involved may be measured by means of a rack controlled by a gear. Thus the distances are proportional to rotation of the gear. The gear can be attached easily to one or more variable electrical resistances. Thus the problem is to find a suitable measuring circuit. The principle of the method which was adopted can be seen by considering fig. 3. The

upper portion of this figure shows a simple voltage divider, in which the potential across the fixed resistance, R_0 , is inversely proportional to the first power of the variable resistance R . If one thinks of applying another similar voltage divider as in the bottom part of fig. 3, the output will be approximately proportional to an inverse square of R . Since the two resistances, R , can be coupled jointly to the gear, it is possible to get an output voltage from such a circuit which is inversely proportional to the square of the distance traversed by the rack. This, of course, is the desired situation.

The double voltage divider of fig. 3 has an actual output voltage which is more complex than the approximation given above. We shall now calculate the true output, E . The total resistance, R_t , of the entire circuit is

$$R_t = R + \frac{1}{1/R_0 + 1/(R + R_0)} = \frac{R^2 + 3RR_0 + R_0^2}{R + 2R_0}$$

If the input voltage is V , the total current, I_t , flowing through the circuit is

$$I_t = \frac{V}{R_t} = \frac{V(R + 2R_0)}{R^2 + 3RR_0 + R_0^2} \quad (4)$$

Now the voltage drop from points A to B in fig. 3 is I_1R_0 and also $I_2(R + R_0)$. Since $I_t = I_1 + I_2$, we may write for I_2

$$I_2 = I_t \frac{R_0}{R + 2R_0}$$

Substitution for I_t from (4) yields

$$I_2 = V \frac{R_0}{R^2 + 3RR_0 + R_0^2}$$

Thus $E = I_2R_0$ may be written as

$$E = V \frac{R_0^2}{R^2 + 3RR_0 + R_0^2}$$

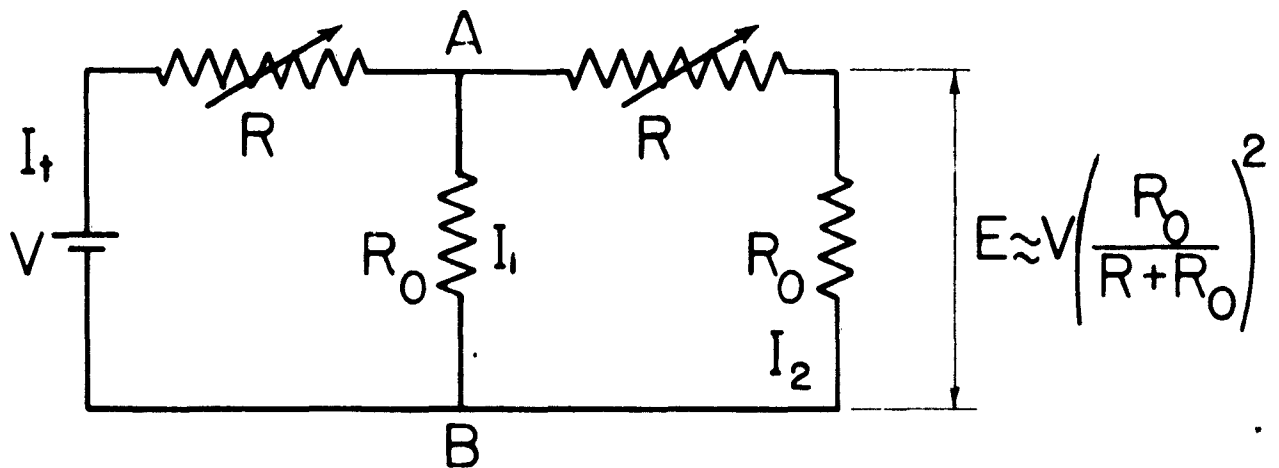
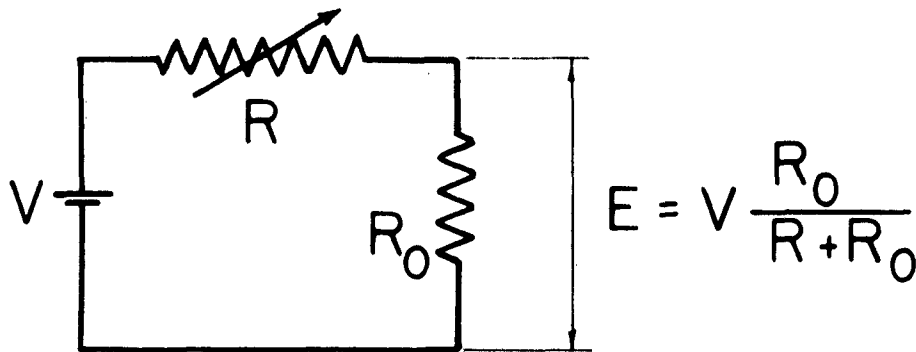

Fig. 3. At the top: a simple voltage divider in which the output voltage is inversely proportional to the first power of the variable resistance, R . At the bottom: a double voltage divider in which the output voltage is approximately inversely proportional to the square of the variable resistance, R .

This may also be written as

$$E = V \frac{R_0^2}{(R + \frac{3}{2} R_0)^2 - \frac{5}{4} R_0^2} \quad (5)$$

If the last term in the denominator of (5) can be kept sufficiently small compared to the first term, we may write

$$E \approx V \frac{R_0^2}{(R + \frac{3}{2} R_0)^2} \quad (6)$$

in which the output voltage is approximately proportional to the inverse square of a linear function of R , as desired. The fractional error in this approximation is $5R_0^2/4(R + 3R_0/2)^2$. Expression (6) is an underestimate of the true value given by (5). However, there is little difficulty in keeping this error at an acceptably low value. Thus, for the adopted value $R_0 = 15$ ohms, if one does not allow R to go below 42.5 ohms the error does not exceed 5 per cent. The restriction to R greater than about 40 ohms is readily accomplished; thus the maximum error from this source is tolerable.

The simple theory given above is for one measuring circuit. Four of these are necessary, connected in series and with appropriate polarities. The polarities are such that the errors discussed above tend to cancel.

4. Design details

The completed instrument is shown in use in fig. 4. The four racks are attached to shafts which slide in grooves machined in plexiglas. The steel racks are 5 inches long and are operated by brass gears of 50 pitch and pitch diameter 1.360 inches. This permits a range in the displacement of the end of a shaft from the center point by a factor of 10.

Each gear is coupled to a wheel for manual control and to a pair of matched, coupled, variable resistances (R in fig. 3). These potentiometers have a maximum resistance of 500 ohms, are accurate to within 2

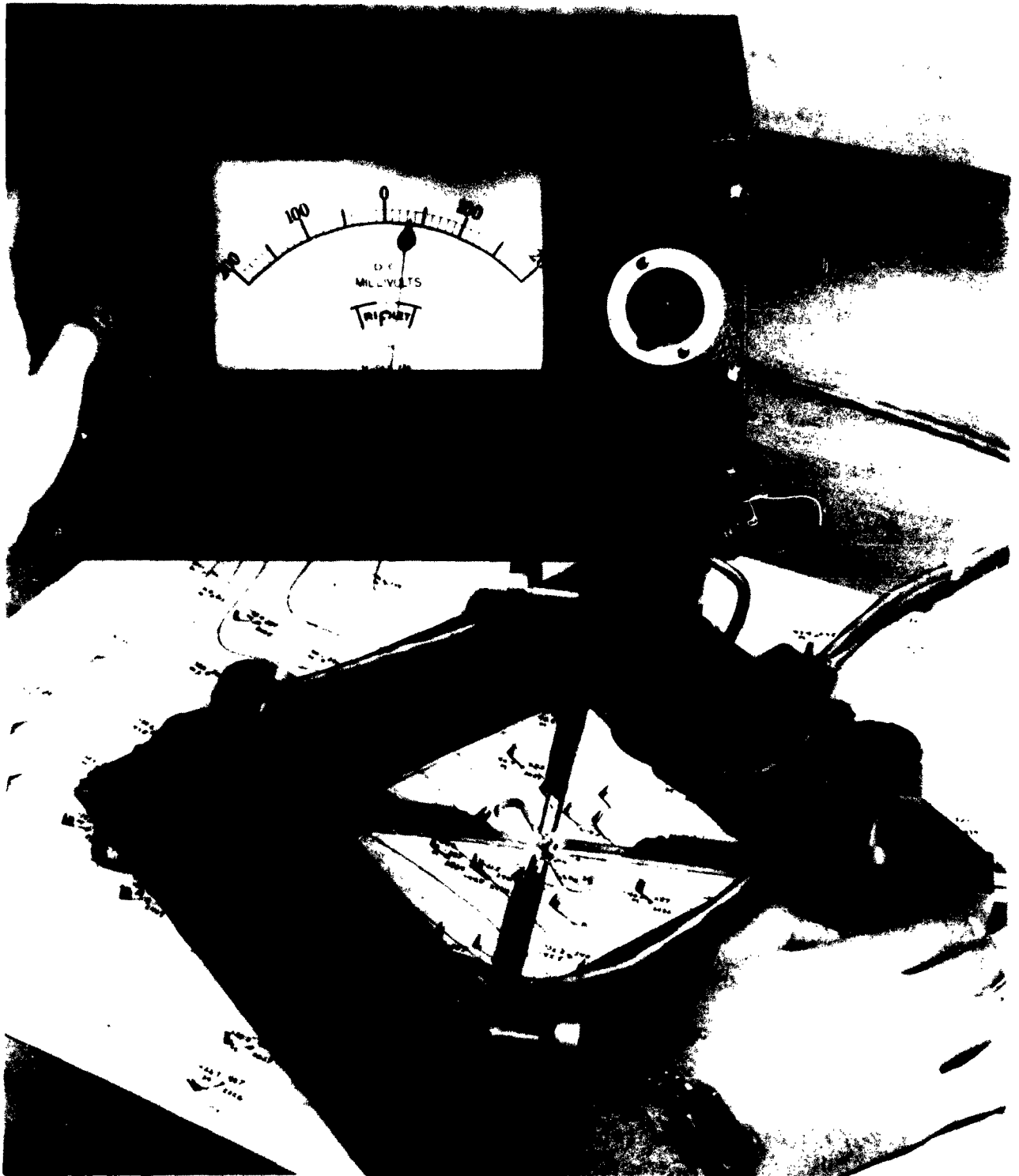

Fig. 4. The computer in operation. At the lower right is the measuring frame. The central hole has been placed on a contour and the ends of the measuring shafts have been set on adjacent contours. The variable resistances, gears, and control knobs are at the four corners of the frame. At the upper left is a case containing the power supply, resistors, etc. On the face of the case, from left to right, are the on-off switch, millivoltmeter, and latitude selector switch.

per cent of the required value at any setting between 45 and 500 ohms, and have a rotation of 300°. They were supplied by the Clarostat Co. Two-watt potentiometers were ordered; however, it would have been convenient to have had a higher wattage.

The plexiglas, through which the underlying map may be viewed, had a hole drilled to mark the center point. Beside this, two large openings were cut to permit written entries to be made on the map.

The remainder of the circuitry, the power supply and meter are mounted in a separate case connected to the meter by a twelve-conductor cable. A schematic wiring diagram is given in fig. 5. The 15 ohm resistors (R_0 of fig. 3) are accurate to within 1 per cent. The power supply for each measuring circuit consists of three mercury batteries in series, giving a no-load potential of 4.035 volts. These are Mallory RM-42R cells with a rated capacity of 14,000 milliampere-hours. Mercury cells were chosen because of their long shelf life and constancy of output. In practice, under load, the output is closer to 3.75 volts. In order to prevent excessive current drain, each circuit is normally open. To make a reading, a switch must be depressed which closes all four circuits simultaneously.

The meter used to measure output is a 200-0-200 millivoltmeter of 547 ohms resistance. In order to prevent overshooting of the pointer at nearly full scale deflections, a 500 microfarad capacitor was connected in parallel across the meter. Since geostrophic vorticity for an isobaric surface is $\zeta = \frac{g}{f} \nabla^2 h$, where g is the acceleration of gravity, f is the Coriolis parameter, and h is geopotential height, it is necessary to allow for the variation with latitude of the factor $1/f$. This is done by providing a number of resistors which may be put in series

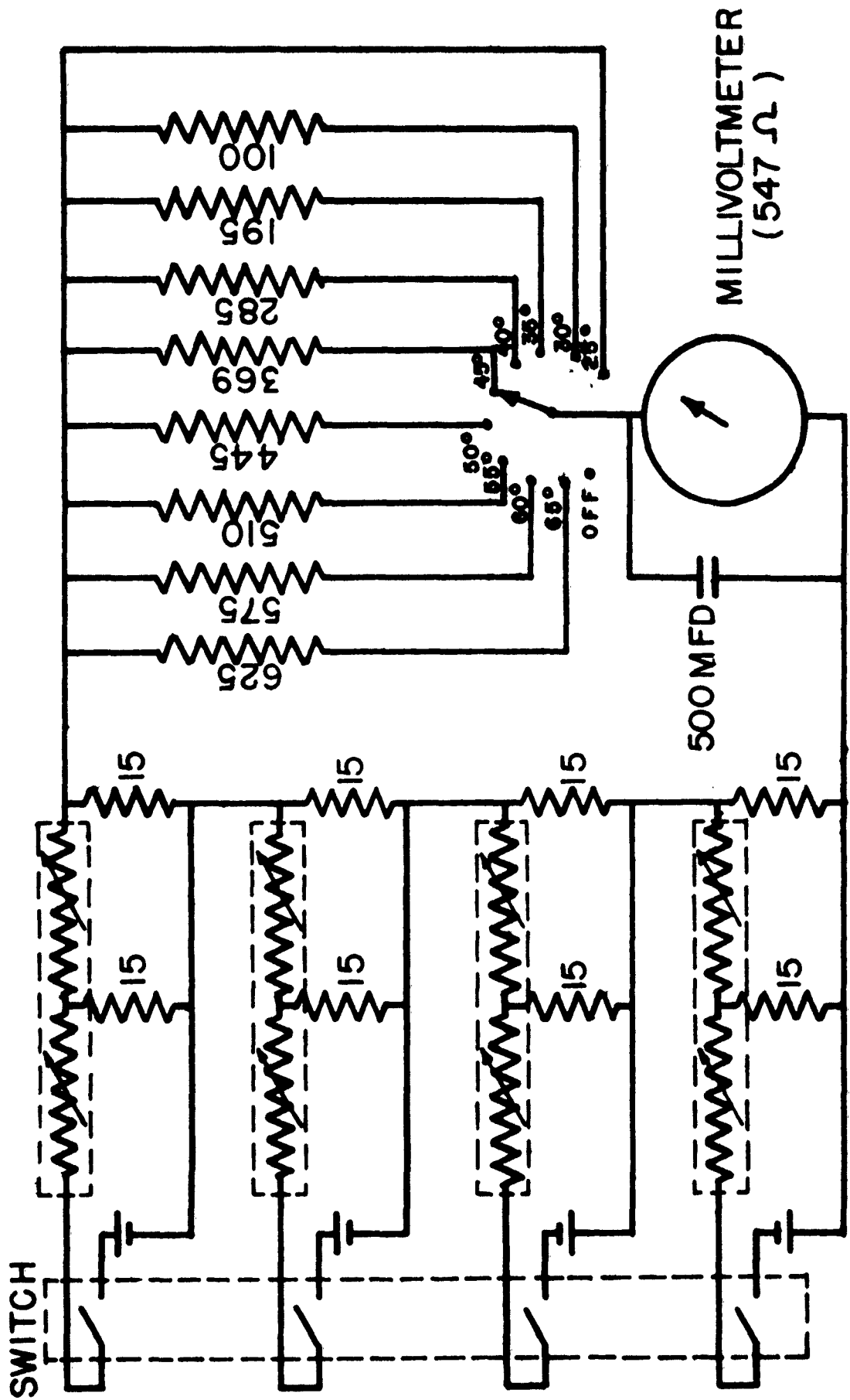

Fig. 5. Schematic wiring diagram of the computer.

with the meter to cut down its sensitivity by appropriate amounts. A selector switch inserts the resistor appropriate to each latitude in 5° steps, from 25° to 65°.

The numerical values which have been given for the various components represent only one suitable combination. There are, of course, many more. In any given subsequent case these values would have to be recalculated to comprise a consistent set. The chief requirements are that R_0 be kept as low as the wattage rating of the potentiometers R will allow, and that the resistance of the meter be as high as is consistent with convenience and sensitivity needs.

5. Operational procedure

The following is a step-by-step procedure for utilizing this computer to determine the geostrophic vorticity.

A. The measuring frame is placed on the map, with the central hole resting on a contour in the region where a measurement is desired, as in fig. 4. The frame should be oriented so the measuring arms make an angle of about 45° with the contours. This angle is not critical. In the model which has been built, the plug on the measuring frame is always kept towards low heights.

B. The latitude control switch is turned to the latitude position nearest to the actual value.

C. The four measuring arms are adjusted until their ends rest on the contours adjacent to the central one.

D. The on-off switch is depressed, causing the meter to indicate.

E. The meter reading is recorded on the map through one of the slots in the plexiglas provided for this purpose.

In practice, two situations have been encountered in which difficulty is experienced. First, if the contour curvature along a trough or ridge line is very great, the measuring arms may not intersect an adjacent contour. To keep this trouble to a minimum, it is advisable to use a base map of sufficiently small scale. When the difficulty arises, it may be reduced further by changing the 45° orientation of the measuring arms to the contours, or by using intermediate contours. Whenever intermediate contours (half the usual height increment) are used, the meter results must be divided by two.

The second difficulty arises in closed centers. The following approximate procedure has been used in such situations with success. Place the central point of the measuring frame in the center of the closed contour. Put two of the measuring arms (having the same polarity) on the innermost closed contour with the other two arms as far out as possible. Note the meter reading, then run out the two arms which were in and place the two arms which were out on the closed contour. Note the meter reading. Next, multiply the absolute sum of the two readings by that fraction of the standard height interval between contours which it is estimated lies between the closed contour and the center of the system. This procedure is based upon the fact that a measuring circuit gives a negligible output when its measuring arm is as far out as possible.

In certain circumstances, such as with small height gradients, it may be desirable to utilize intermediate contours, in which case the meter reading should be halved, as indicated above. When the gradients are very large, it is advisable to utilize every other contour (doubled

interval). Then the meter readings must be doubled before being plotted.

6. A comparative test

In order to test the accuracy and utility of the computer, a synthetic height field was constructed as shown in fig. 6. This is the sum of two fields, one of circular, equally spaced contours, and the other of straight parallel contours extending from left to right with anti-cyclonic shear. The true Laplacian of this field is known and is shown in fig. 7a. The value of vorticity at the center of the pattern is infinite; thus, it is inevitable that any finite difference method for estimating the Laplacian will be in error close to the center. However, it will be of interest to note how close various methods can come to this unattainable pattern.

The Laplacian evaluated by means of the computer is shown in fig. 7b. It can be seen that the general shape of the true pattern has been portrayed successfully. The smoothing involved in the use of finite differences causes the absolute values to be smaller than they should be and weakens the gradients, especially near the center. Fig. 7c gives the Laplacian obtained by the graphical technique of evaluating equation (1), given by Fjörtoft (1952). The differentiation distance, L , was taken to be 4° of latitude. It is obvious that this method smooths the field considerably and so markedly lowers the magnitudes and gradients. Fig. 7c could hardly be accepted as an adequate representation of fig. 7a, except for the most gross applications. The difference between 7b and 7c is largely due to the change in the distance over which the finite differences are taken in the two cases. In 7b the differentiation distance is roughly the distance between the contours of fig. 6. This is variable, but is approximately 1° of latitude. It is desirable to compare the results obtained with the computer to

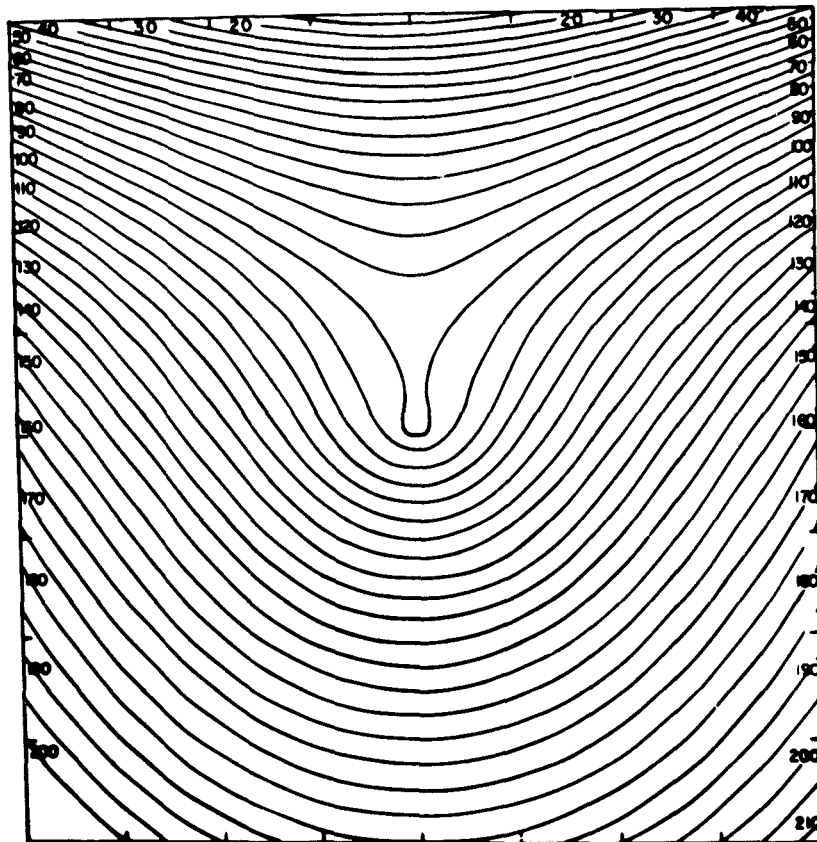

Fig. 6. Synthetic contour pattern for an isobaric surface. The lines are labelled with values in tens of feet. The distance between adjacent tick marks represents 1° of latitude.

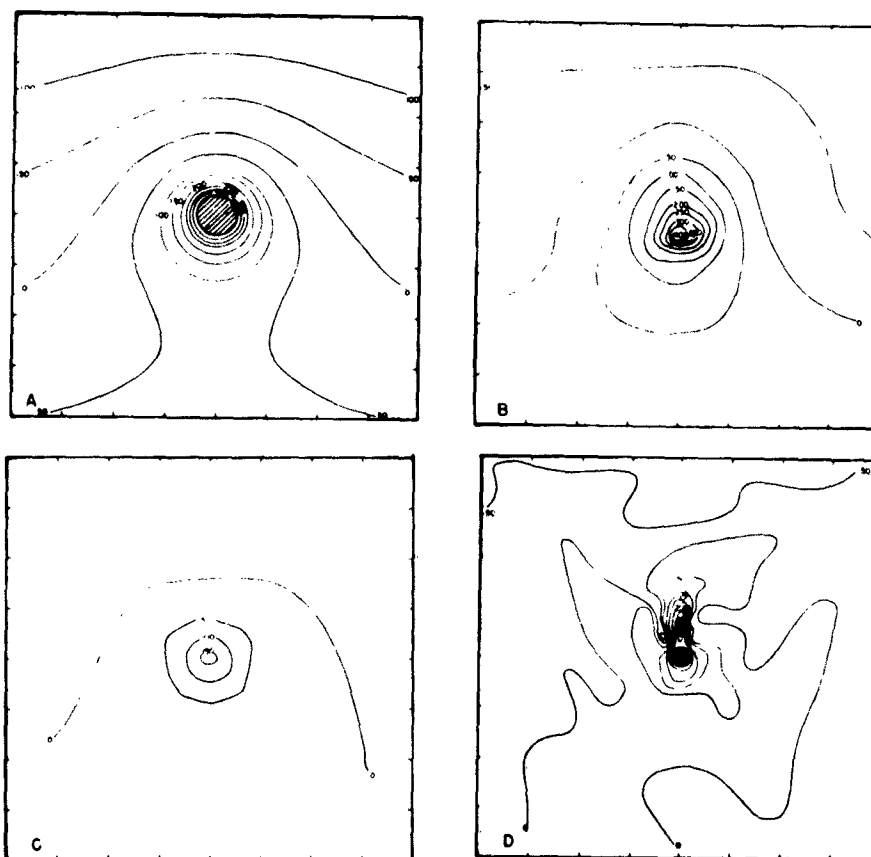

Fig. 7. Four different representations of the Laplacian of the height field of fig. 6. A is the true Laplacian in which isopleths have not been drawn in the hatched region; B is the field determined by the graphical method of Fjørtoft using a differentiation distance of 4° of latitude; D is the field determined by interpolation using a differentiation distance of 1° of latitude. In all four cases the numerical values are expressed in feet and are directly comparable. The values are those of $L^2 \nabla^2 h$ where L is 4° of latitude in each case. In B, C, and D the lines have been smoothed to a roughly equal, small degree.

those obtained with a standard technique using a comparable differentiation distance. Fig. 7d gives the results of applying equation (1), where $L = 1^\circ$ of latitude. Although the central values and gradients are satisfactory, it is clear that the field of the Laplacian is highly irregular and erratic. This is because equation (1) requires that two successive differences of interpolated values be taken. As the differentiation distance, L , becomes smaller it is necessary that the accuracy of interpolation increase, in order that the accuracy of the differences remain constant. When the grid distance is as small as 1° of latitude, the results are affected significantly by random errors. This demonstrates that information concerning the derivatives of a field may be extracted more accurately by measuring distances between lines in the field than by interpolation.

It is perhaps worth pointing out that in obtaining fig. 7d the graphical process could not be used. This is because the graphical technique requires that the difference be found between a smoothed field, $(h_1 + h_2 + h_3 + h_4)/4$, and the unsmoothed field. If the distance, L , is too small, there is so little difference between the smoothed and unsmoothed fields that when superimposed they do not intersect each other and the graphical subtraction cannot be performed. The Fjørtoft technique for evaluating the Laplacian cannot be applied ordinarily unless large differentiation distances are used.

7. Possible improvements

In many applications in meteorology it is the distribution of absolute vorticity about the vertical which is desired rather than the distribution of the relative vorticity. This requires that the Coriolis parameter be added to the relative vorticity. The addition is frequently

omitted with the justification that the gradient of the Coriolis parameter is relatively small. There are undoubtedly occasions in which it is desirable to avoid this additional error, and the reason for failing to avoid it is the inconvenience incurred with existing procedures. When using the computer described here, it would be simple to use a double gang switch for the latitude control, and have the second gang operate a selective voltage divider which could then apply an additional potential to the meter, proportional to the value of the Coriolis parameter. Since the addition would be done electrically, one could obtain the absolute vorticity or the relative vorticity at will, with no further effort on the part of the operator.

Undoubtedly, there are other arrangements and designs which would be as effective or more so than the present one. For example, it is possible to use, instead of four measuring arms, a system of three, passing through the vertices of an equilateral triangle. This would avoid the difficulty which is experienced with the present apparatus in the vicinity of sharply curved contours. The electrical analog might then be more complicated; however, this question has not been looked into.

Once it is realized that any desired combination of space derivatives of a mapped field can be obtained by mechanical measurement of the distances between isopleths of the field combined with electrical analog computation, a whole host of possibilities suggest themselves. For example, in evaluating vorticities it ought to be possible to take into account the fact that the geostrophic vorticity is an overestimate in troughs and an underestimate in ridges. The electrical analog could be so constructed as to include this automatically in the result.

8. Conclusions

The electrical analog computer described here has been tested, as discussed, and was used for a period of two weeks in the current weather analysis program conducted by graduate students at the Florida State University. The results of this experience indicate that one can evaluate the geostrophic vorticity rapidly and accurately by this technique. There is reason to believe that the process of measurement is sufficiently simple that sub-professional persons could carry it out successfully. With a little experience, the procedure should be faster than the previously used methods without loss of accuracy.

9. Acknowledgement

Thanks are due to Dr. Guenter Schwarz of the Department of Physics at the Florida State University for advice and consultation on circuitry.

REFERENCE

- Fjörtoft, R. 1952: On a numerical method of integrating the barotropic vorticity equation. Tellus, 4, 179-194.

October 1, 1955

Contract No. Nonr-1600(00)

DISTRIBUTION LIST FOR UNCLASSIFIED TECHNICAL REPORTS

<u>Addressee</u>	<u>No. of Copies</u>
Geophysics Branch, Code 416, Office of Naval Research, Washington 25, D. C.	2
Director, Naval Research Laboratory, Attention: Technical Information Officer, Washington 25, D. C.	6
Office of Naval Research, Resident Representative, Georgia Institute of Technology, 680 Cherry Street, Atlanta, Georgia	1
Office of Technical Services, Department of Commerce, Washington 25, D. C.	1
Armed Services Technical Information Center, Documents Service Center, Knott Building, Dayton 2, Ohio	5
Assistant Secretary of Defense for Research and Development, Attention: Committee on Geophysics and Geography, Pentagon Building, Washington 25, D. C.	1
Department of Aerology, U. S. Naval Post Graduate School, Monterey, California	1
Aerology Branch, Bureau of Aeronautics (Ma-5), Navy Department, Washington 25, D. C.	1
Mechanics Division, Navy Research Laboratory Anacostia Station, Washington 20, D. C., Attention: J. E. Dinger, Code 3820	1
Radio Division I, Code 3420, Naval Research Laboratory Anacostia Station, Washington 20, D. C.	1
Meteorology Section, Navy Electronics Laboratory, San Diego 52, California, Attention: L. J. Anderson	1
Library, Naval Ordnance Laboratory, White Oak, Silver Spring 19, Maryland	1
Bureau of Ships, Navy Department, Washington 25, D. C. Attention: Code 327, (Technical Library)	2
Chief of Naval Operations, Navy Department, Washington 25, D. C., Attention: Op-533D	2
Director of Research, R. D. 3, Schermerhorn Road, Schenectady, New York	1

Library, Willow Run Research Center, University of Michigan, Willow Run Airport, Ypsilanti, Michigan	1
Oceanographic Division, U. S. Navy Hydrographic Office, Suitland, Maryland	2
Library, Naval Ordnance Test Station, Inyokern, China Lake, California	1
Project AROMA, U. S. Naval Air Station, Building #m18, Norfolk, Virginia	2
The Chief, Armed Forces Special Weapons Project, P. O. Box 2610, Washington D. C.	1
Office of the Chief Signal Officer, Engineering and Technical Service, Washington 25, D. C. Attention: SIGGGM	1
Meteorological Branch, Evans Signal Laboratory, Belmar, New Jersey	1
Commanding General, Hq. Quartermaster Research and Development Command, Quartermaster Research and Development Center U. S. Army, Natick, Massachusetts, Attention: Chief, Environmental Research Branch	1
Office of the Chief, Chemical Corps, Research and Engineering Division, Research Branch, Army Chemical Center, Maryland	2
Commanding Officer, Air Force Cambridge Research Center, 230 Albany Street, Cambridge, Massachusetts, Attention: ERHS-1	1
Headquarters, Air Weather Service, Andrews A. F. Base, Washington 20, D. C., Attention: Director Scientific Services	2
Commander, Wright Air Development Center, Attention: WCLRA Library, Wright Patterson A. F. Base, Ohio	1
Commanding General, Air Force Cambridge Research Center, L. G. Hanscom Field, Bedford, Massachusetts, Attention: CRHSL	1
Commanding General, Air Research and Development Command, P. O. Box 1395, Baltimore 3, Maryland, Attention: RDDG	1
Department of Meteorology, Massachusetts Institute of Technology, Cambridge, Massachusetts	1
Department of Meteorology, University of Chicago, Chicago 37, Illinois	1
Institute for Advanced Study, Princeton, New Jersey	1

The Johns Hopkins University, Department of Civil Engineering, Baltimore, Maryland	1
Department of Meteorology, Pennsylvania State University, University Park, Pennsylvania	1
Scripps Institute of Oceanography, La Jolla, California	1
General Electric Research Laboratory, Schenectady, New York, Attention: I. Langmuir	1
St. Louis University, 3621 Olive Street, St. Louis 8, Missouri	1
Department of Meteorology, University of California at Los Angeles, Los Angeles, California	1
Department of Engineering, University of California at Los Angeles, Los Angeles, California	1
Woods Hole Oceanographic Institution, Woods Hole, Mass.	1
The Johns Hopkins University, Department of Physics, Homewood Campus, Baltimore, Maryland	1
New Mexico Institute of Mining and Technology, Research and Development Division, Socorro, New Mexico	1
Geophysical Institute, University of Alaska, College, Alaska, Attention: C. T. Elvey	1
Blue Hill Meteorological Observatory, Harvard University, Milton 86, Massachusetts, Attention: C. Brooks	1
Department of Meteorology, New York University, New York 53, N. Y.	1
Texas A and M, Department of Oceanography, College Station, Texas	1
Rutgers University, College of Agriculture, Department of Meteorology, New Brunswick, New Jersey	1
National Advisory Committee of Aeronautics, 1500 New Hampshire Avenue, NW, Washington 25, D. C.	2
U. S. Weather Bureau, 24th and M Sts., N. W., Washington 25, D. C., Attention: Scientific Services Division	2
Air Coordinating Committee, Subcommittee on Aviation Meteorology, Room 2D889-A, The Pentagon, Washington 25, D. C.	1
American Meteorological Society, 3 Joy Street, Boston 8, Mass., Attention: The Executive Secretary	1
University of Pennsylvania, Department of Meteorology, Philadelphia, Pennsylvania	1