

# DESIGN AND APPLICATION OF A DIODE-DIRECTED SOLID-STATE MARX MODULATOR\*

G.E. Dale<sup>‡</sup>, H.C. Kirbie, W.B. Haynes, C.E. Heath,  
T.A. Lopez, F.P. Romero, and R.M. Wheat Jr.  
Los Alamos National Laboratory, PO Box 1663, Mail Stop J-570  
Los Alamos, NM, USA

## Abstract

Researchers at Los Alamos National Laboratory (LANL) are developing a new solid-state high-voltage Marx modulator for the generation of pulsed power. The initial application of the LANL modulator is to provide power to a magnetron that requires a 46-kV, 160-A, 5- $\mu$ s rectangular pulse. This modulator technology is also being developed for other applications, including portable millimeter wave sources, a beam energy corrector for induction accelerators, and space-based power systems. The LANL solid-state modulator has several benefits, including wave shape control, switch protection, efficiency, and compactness. The present paper describes this source technology and its design.

## I. INTRODUCTION

The traditional Marx generator, named for its inventor, Professor Erwin Marx [1], produces a single high-voltage pulse by switching precharged capacitors into a series-connected string using gas-insulated spark gaps [2]. The Marx generator is a rugged, low-impedance source of electrical energy that has served well in a wide variety of high-peak-power applications for the past 75 years. Marx generators are now undergoing a renaissance due to the use of modern solid-state switches [3-8]. The use of insulated gate bipolar transistors (IGBT) in place of spark gaps, for example, gives simple Marx generators the ability to produce square-shaped output pulses at very high rates. The on/off switching capability of the IGBT also allows the output pulse to change width from one pulse to the next, enabling the generator to adapt rapidly to changing load requirements. Currently, Marx generators using solid-state switches are unable to equal the high peak voltage and peak power capacity of generators using spark gaps, but the operational advantages gained in pulse control and high average power have transformed the single-shot Marx generator into a versatile modulator.

A schematic of a typical resistively charged Marx generator is shown in Figure 1. Other Marx configurations use inductors in place of the charging resistors. Our Marx modulator replaces these linear charging elements with fast-recovery diodes [9], as shown in Figure 2. The diodes provide a low-loss, low-impedance path for the Marx charging current between pulses and a high-impedance path when the Marx bank is erected.

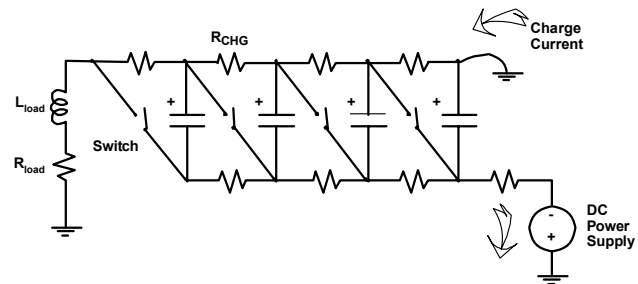


Figure 1. Simplified diagram of a four-stage Marx modulator with resistive charging elements.

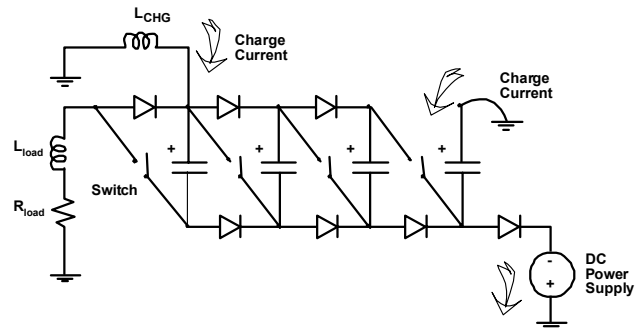


Figure 2. Simplified diagram of a four-stage Marx modulator with diode charging elements.

The charging inductor shown in Figure 2 is necessary to complete the charging pathway when the Marx bank can not be charged through the load (such as when used to power a magnetron). Supply current enters the Marx circuit through the charging inductor, trickles through the Marx assembly via diode routing, and returns to the power supply near the grounded end. The charging

\* Work sponsored by Los Alamos National Laboratory under US DOE contract W-7405-ENG-36.

<sup>‡</sup> email: gedale@lanl.gov

## Report Documentation Page

*Form Approved*  
*OMB No. 0704-0188*

Public reporting burden for the collection of information is estimated to average 1 hour per response, including the time for reviewing instructions, searching existing data sources, gathering and maintaining the data needed, and completing and reviewing the collection of information. Send comments regarding this burden estimate or any other aspect of this collection of information, including suggestions for reducing this burden, to Washington Headquarters Services, Directorate for Information Operations and Reports, 1215 Jefferson Davis Highway, Suite 1204, Arlington VA 22202-4302. Respondents should be aware that notwithstanding any other provision of law, no person shall be subject to a penalty for failing to comply with a collection of information if it does not display a currently valid OMB control number.

1. REPORT DATE <b>JUN 2005</b>	2. REPORT TYPE <b>N/A</b>	3. DATES COVERED <b>-</b>	
4. TITLE AND SUBTITLE <b>Design And Application Of A Diode-Directed Solid-State Marx Modulator</b>		5a. CONTRACT NUMBER	
		5b. GRANT NUMBER	
		5c. PROGRAM ELEMENT NUMBER	
6. AUTHOR(S)		5d. PROJECT NUMBER	
		5e. TASK NUMBER	
		5f. WORK UNIT NUMBER	
7. PERFORMING ORGANIZATION NAME(S) AND ADDRESS(ES) <b>Los Alamos National Laboratory, PO Box 1663, Mail Stop J-570 Los Alamos, NM, USA</b>		8. PERFORMING ORGANIZATION REPORT NUMBER	
9. SPONSORING/MONITORING AGENCY NAME(S) AND ADDRESS(ES)		10. SPONSOR/MONITOR'S ACRONYM(S)	
		11. SPONSOR/MONITOR'S REPORT NUMBER(S)	
12. DISTRIBUTION/AVAILABILITY STATEMENT <b>Approved for public release, distribution unlimited</b>			
13. SUPPLEMENTARY NOTES <b>See also ADM002371. 2013 IEEE Pulsed Power Conference, Digest of Technical Papers 1976-2013, and Abstracts of the 2013 IEEE International Conference on Plasma Science. IEEE International Pulsed Power Conference (19th). Held in San Francisco, CA on 16-21 June 2013., The original document contains color images.</b>			
14. ABSTRACT <b>Researchers at Los Alamos National Laboratory (LANL) are developing a new solid-state high-voltage Marx modulator for the generation of pulsed power. The initial application of the LANL modulator is to provide power to a magnetron that requires a 46-kV, 160-A, 5-<math>\mu</math>s rectangular pulse. This modulator technology is also being developed for other applications, including portable millimeter wave sources, a beam energy corrector for induction accelerators, and space-based power systems. The LANL solid-state modulator has several benefits, including wave shape control, switch protection, efficiency, and compactness. The present paper describes this source technology and its design.</b>			
15. SUBJECT TERMS			
16. SECURITY CLASSIFICATION OF:			17. LIMITATION OF ABSTRACT <b>SAR</b>
a. REPORT <b>unclassified</b>	b. ABSTRACT <b>unclassified</b>	c. THIS PAGE <b>unclassified</b>	
			18. NUMBER OF PAGES <b>4</b>
			19a. NAME OF RESPONSIBLE PERSON

inductor is generally sized to shunt no more than 10% of the load current at several times the maximum expected pulse width.

Employing diode charging and solid state switching in a Marx architecture produces significant benefits in efficiency, wave shape control, switch protection, and compactness:

#### A. Efficiency

A Marx bank with resistor charging can be no more than 50% efficient because at least half of the charging energy is dissipated in the charging resistors. In comparison, diode charging of a Marx dissipates very little of the charging energy resulting in a very efficient charging arrangement. Using inductors for Marx charging can also be made to be very efficient, but suffers from pulse width limitations due to saturation. Diode charging has the added benefit of not limiting the pulse width since the diodes can remain reverse biased indefinitely (when used, an external charging inductor can limit the pulse width and so needs to be designed appropriately).

Another efficiency benefit of using diode charging is that it facilitates the recycling of energy that would otherwise be lost. When the switches shown in Figure 2 are closed, the diodes are reversed-biased. When the switches open, energy stored in the charging and load inductances causes the diodes to become forward biased, directing this inductively stored energy back into the stage capacitors. Although the charging inductor siphons off some of the Marx output pulse, this inductively stored energy is given back (recycled) after each pulse.

#### B. Wave-Shape Control

The combination of solid-state switches and diode charging adds the new and powerful dimension of tailoring the output pulse for optimal performance at the load through the unique ability to operate each stage independently. Stages not receiving a switching command are bypassed by the charging diodes, an arrangement producing an output pulse voltage equal to the charge voltage times the number of active stages. Similarly, the independent stages can be switched on and off within a single pulse envelope to produce a digitally synthesized pulse shape.

#### C. Switch Protection

The diode architecture that increases the Marx efficiency in our modulator also intercepts destructive transient energy and returns it safely to the energy-storage capacitors for reuse. The switches used in modern Marx-type modulators are steadily increasing in peak and average power-handling capacity, but the drawback is their susceptibility to switch damage from energy transients. The traditional approach to addressing this problem is to absorb and dissipate the incoming transient energy by connecting snubbing circuits in parallel with the endangered switches. A higher level of protection is provided by our Marx architecture by directing the

transient energy around the vulnerable switches into the stage capacitors through the charging diodes. We believe this approach may eliminate the need for snubbing circuits entirely in future versions of the modulator.

#### D. Size and Weight

Our fully solid-state modulator is inherently compact and lightweight. The basic architecture of the modulator will allow it to keep pace with the demands of research, the military, and industry for high-peak and high-average-power sources in ever-smaller and ever-lighter packages. Our Marx modulator does not use a large, heavy transformer to produce high voltage. Moreover, since all charging, switching, and gate-control components are solid-state, we have the option of purchasing their silicon interiors (dies) instead of encapsulated components. Therefore, each Marx stage can be made very small and light, either by combining the dies in a multichip module or combining their functions within a single application-specific integrated circuit (ASIC). This possibility leaves the volume of the energy storage capacitors as the dominant factor determining the dimensions. Since the history of capacitor technology demonstrates steadily increasing energy density, in the future it is likely we will be able to reduce the size of our Marx modulators even further [10]. Use of all-solid-state construction in a Marx generator has the added benefit of minimizing the heat generated during operation, a result that allows reduction in the size and complexity of the attendant cooling system. In our first application, the relatively low output voltage has allowed more weight reduction through the use of sulfur hexafluoride gas ( $\text{SF}_6$ ) for the insulating and cooling medium.

## II. SYSTEM DESCRIPTION

We developed our Marx modulator to fill the power-source needs of several applications, each possessing its own set of parameters for weight, size, output voltage, current, pulse width, repetition rate, and average power. The first of these applications is a compact, gas-insulated power source designed to deliver a 46-kV, 160-A, 5- $\mu\text{s}$  rectangular pulse to the cathode of a magnetron. The magnetron is an S-band e2v Model 6028 with the performance parameters listed in Table 1.

**Table 1.** Magnetron performance parameters.

Voltage	46 kV
Current	160 A
Pulse Width	5 $\mu\text{s}$
Energy per pulse	36.8 J
RF peak power	$\sim 3.5$ MW
Rate of voltage rise	$< 130$ kV/ $\mu\text{s}$
Average power limit	7 kW (input)

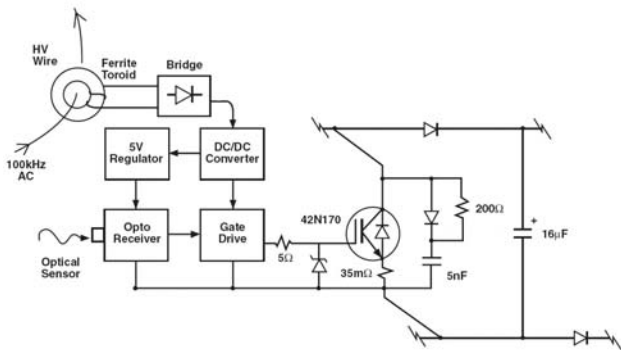
The magnetron produces a nominal load impedance of 288  $\Omega$  and requires a pulse that is reasonably flat ( $< 5\%$ )

when averaged over the pulse width. The modulator is designed to obtain the pulse flatness by storing about 15 times the energy needed by a single pulse. The droop can be further reduced by either adding more stage capacitance, using a passive droop compensation network [3], or active compensation by wave-shape control.

The key parameters of the modulator are shown in Table 2. Each stage consists of a single IGBT, two 8- $\mu\text{F}$  capacitors connected in parallel, two fast-recovery diodes, a single gate driver, and an isolated power supply deriving its energy from a ferrite isolation transformer. The IGBT and gate-control elements are shown in Figure 3.

**Table 2.** Marx modulator parameters.

Max. stage voltage	1200 V
Number of stages	48 (57.6 kV open circuit)
Capacitance per stage	16 $\mu\text{F}$
Total Marx capacitance	786 $\mu\text{F}$
Max. stored energy	553 J
Erected capacitance	333 nF
Uncompensated droop	$\sim 5\%$



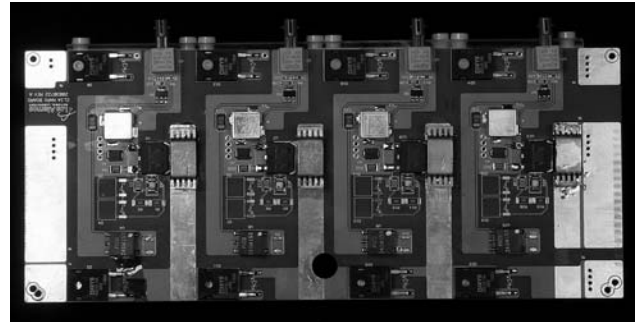
**Figure 3.** Schematic illustration of a single Marx stage.

The IGBTs are triggered independently by fiber optic signals received through an optical interface on each stage. We selected the IXYS model IXBT42N170 for the Marx stage switch because it is a good compromise between operating voltage, pulsed current, and commutation speed [11]. We chose the IXYS model DSDI60 fast-recovery diode for the charging elements and a self-healing film capacitor from Aerovox for energy storage.

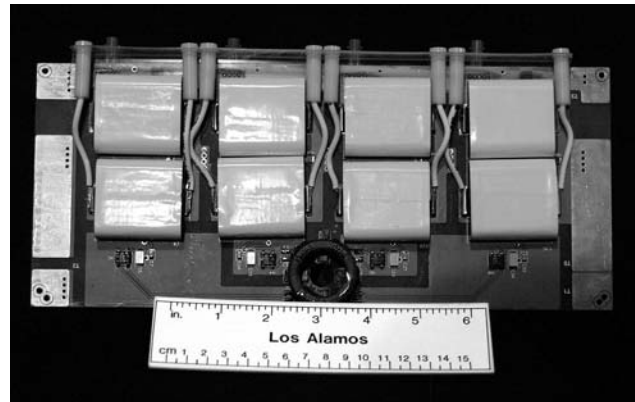
Four Marx stages are collected on a single circuit board measuring 12.7 cm x 30.5 cm. Figures 4 and 5 show two views of a single circuit board. Each stage is powered by a separate winding on a common ferrite transformer core with a single high-voltage wire serving as the primary winding for the ferrite transformer. The primary winding is powered from an H-bridge power converter operating at 100 kHz.

The entire modulator assembly consists of twelve of these circuit boards. The circuit boards are rack-mounted on rails in a folded arrangement that saves space. The

centers of each ferrite transformer share a common axis through which the primary winding is threaded. The boards are supported on the assembly rails by modified circuit card connectors. These circuit card connectors also serve to electrically interconnect the Marx boards in series using a copper strip.

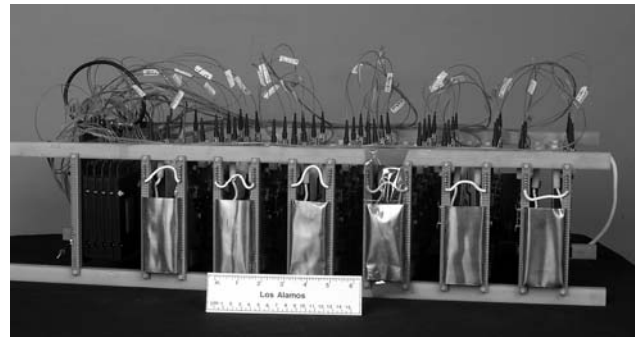


**Figure 4.** Front view of the circuit board showing four optical fiber ports, four switches, and four metal enclosures containing the gate drive electronics.



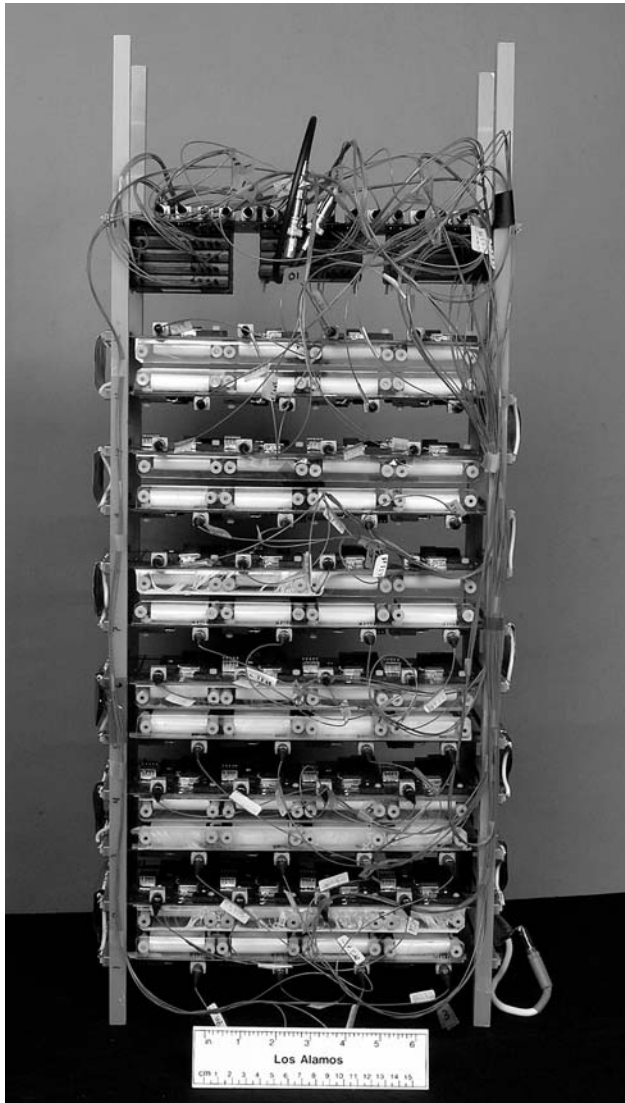
**Figure 5.** Rear view of the circuit board showing eight 8- $\mu\text{F}$ , 1500-V capacitors and a single ferrite-core transformer.

Two views of the assembled modulator are shown in Figures 6 and 7. The assembled modulator weighs 11 kg, and measures 76.2 cm x 30.5 cm x 17.8 cm.



**Figure 6.** Top view of the assembled modulator showing support rails and edge connectors. Board spacing on the rails is generous to allow single stage measurements.

The modulator has been extensively tested into a 300  $\Omega$  resistive load. Detailed performance results are contained in a companion paper [12].



**Figure 7.** Top view of assembled modulator showing fiber-optic trigger cables.

### III. CONCLUSIONS

We have produced an efficient power converter that takes in low-voltage dc power and puts out a steady stream of high voltage pulses in a package with an ultra-compact future [13]. In addition to building this modulator to power a magnetron, we are also developing this modulator technology for other applications. These future applications include modulators for portable millimeter wave sources, an active tuning system for pulse forming networks, a beam energy corrector for induction accelerators, and spaced-based power systems.

The key element of the modulator is its unique Marx circuit architecture that manages the outflow of power to the load with advanced solid-state switches and uses diodes to direct the flow of all incoming power, transient or otherwise, to the capacitors. The charging diodes provide high shunt impedance to the outflow of power (when the diodes are off) and converts to a very low shunt impedance to the inflow of power (when the diodes are on), regardless of whether that power comes from a dc power supply or a high-power transient.

### IV. REFERENCES

- [1] J. Salge, "Professor Erwin Marx," in Proc. 4th IEEE International Pulsed Power Conference, 1983, pp. 51.
- [2] E. Marx, "Verfahren zur Schlagprüfung von Isolatoren und anderen elektrischen Vorrichtungen," Deutsches Patent No. 455933, 1928.
- [3] A. Krasnykh, R. Akre, S. Gold and R. Koontz, "A solid state Marx type modulator for driving a TWT," in Proc. Power Modulator Symposium, 2000, pp. 209-211.
- [4] J. Baek, D. Voo and G. Rim, "Solid-State Marx Generator Using Series Connected IGBTs," in Proc. Power Modulator Symposium, 2004, pp. 383-386.
- [5] S.G.E. Pronko, M.T. Ngo and R.K.F. Germer, "A solid-state Marx-type trigger generator," in Proc. Power Modulator Symposium, 1988, pp. 211-214.
- [6] R.L. Cassel, "A solid state high voltage pulse modulator which is compact and without oil or a pulse transformer," in Proc. Power Modulator Conference, 2004, pp. 72-74.
- [7] K. Okamura, S. Kuroda and M. Maeyama, "Development of the high repetitive impulse voltage generator using semiconductor switches," in Proc. Pulsed Power Conference, 1999, pp. 807-10.
- [8] J.A. Casey, F.O. Arntz, M.P.J. Gaudreau and M.A. Kempkes, "Solid-state Marx bank modulator for the next linear collider," in Proc. Power Modulator Symposium, 2004, pp. 257-260.
- [9] G.E. Dale, H.C. Kirbie, J.D. Doss and M.A. Serrano, "Solid-State Marx Modulator Development," in Proc. Power Modulator Conference, 2004, pp. 497-500.
- [10] F.W. MacDougall, J.B. Ennis, R.A. Cooper, J. Bates and K. Seal, "High energy density pulsed power capacitors," in Proc. Pulsed Power Conference, 2003, pp. 513-517.
- [11] B. Hickman and E. Cook, "Evaluation of MOSFETs and IGBTs for pulsed power applications," in Proc. Pulsed Power Plasma Science, 2001, pp. 1047-1050.
- [12] G.E. Dale, H.C. Kirbie, W.B. Haynes, C.E. Heath, T.A. Lopez, F.P. Romero, and R.M. Wheat Jr., "Performance of a Diode-Directed Solid-State Marx-Modulator," presented at the 15th IEEE International Pulsed Power Conference, Monterey, CA, 2005.
- [13] M.V. Fazio and H.C. Kirbie, "Ultrapact pulsed power," Proc IEEE, vol. 92, pp. 1197-204, 2004.