

AD _____

Award Number: W81XWH-12-1-0013

TITLE: Whole Exome Analysis of Early Onset Alzheimer's Disease

PRINCIPAL INVESTIGATOR: Margaret Pericak-Vance

CONTRACTING ORGANIZATION: University of Miami, Miami, FL 33136

REPORT DATE: April. 2013

TYPE OF REPORT: Annual

PREPARED FOR: U.S. Army Medical Research and Materiel Command
Fort Detrick, Maryland 21702-5012

DISTRIBUTION STATEMENT: Approved for Public Release;
Distribution Unlimited

The views, opinions and/or findings contained in this report are those of the author(s) and should not be construed as an official Department of the Army position, policy or decision unless so designated by other documentation.

REPORT DOCUMENTATION PAGE			Form Approved OMB No. 0704-0188		
Public reporting burden for this collection of information is estimated to average 1 hour per response, including the time for reviewing instructions, searching existing data sources, gathering and maintaining the data needed, and completing and reviewing this collection of information. Send comments regarding this burden estimate or any other aspect of this collection of information, including suggestions for reducing this burden to Department of Defense, Washington Headquarters Services, Directorate for Information Operations and Reports (0704-0188), 1215 Jefferson Davis Highway, Suite 1204, Arlington, VA 22202-4302. Respondents should be aware that notwithstanding any other provision of law, no person shall be subject to any penalty for failing to comply with a collection of information if it does not display a currently valid OMB control number. PLEASE DO NOT RETURN YOUR FORM TO THE ABOVE ADDRESS.					
1. REPORT DATE April 2013		2. REPORT TYPE Annual Report		3. DATES COVERED F April 2012 to March 31, 2013	
4. TITLE AND SUBTITLE Whole Exome Analysis of Early Onset Alzheimer's Disease			5a. CONTRACT NUMBER		
			5b. GRANT NUMBER W81XWH -12-1-0013		
			5c. PROGRAM ELEMENT NUMBER		
6. AUTHOR(S) Margaret A. Pericak-Vance, Ph.D. E-Mail: mpericak@med.miami.edu			5d. PROJECT NUMBER		
			5e. TASK NUMBER		
			5f. WORK UNIT NUMBER		
7. PERFORMING ORGANIZATION NAME(S) AND ADDRESS(ES) University of Miami, Miami, FL 33136			8. PERFORMING ORGANIZATION REPORT NUMBER		
9. SPONSORING / MONITORING AGENCY NAME(S) AND ADDRESS(ES) U.S. Army Medical Research and Materiel Command Fort Detrick, Maryland 21702-5012			10. SPONSOR/MONITOR'S ACRONYM(S)		
			11. SPONSOR/MONITOR'S REPORT NUMBER(S)		
12. DISTRIBUTION / AVAILABILITY STATEMENT Approved for Public Release; Distribution Unlimited					
13. SUPPLEMENTARY NOTES					
14. ABSTRACT The primary focus toward identification of Alzheimer disease (AD) risk genes over the past five years has been testing the common disease common variant (CDCV) hypothesis through the use of genome-wide association studies (GWAS) in late onset Alzheimer disease (LOAD). While common variation clearly plays a role in AD there is a growing realization that the CDCV hypothesis is unlikely to explain all the genetic effect underlying AD. One alternative hypothesis invokes multiple rare variants (RV) in one or more genes, each with stronger individual effects than CDCV genes. We designed this project to test the rare variant hypothesis in AD by examining those cases with the most severe phenotype as determine by early onset (EOAD, cases with AAO < 60 years). Although there are three known EOAD genes (PS1, PS2 and APP) they account for only ~60-70% of familial EOAD and even less of sporadic EOAD. Thus, the majority of the genetics of EOAD remains unknown. Until now, large extended families with AD in multiple generations were necessary to identify variants of significant effect contributing to AD risk, however, with the advent of new genomic technologies such as high-throughput sequencing technology, small family aggregates and isolated cases, particularly those with an extreme phenotype of the disorder (such as early onset) can be used. Thus, we will utilize whole exome high-throughput sequencing to identify high risk AD variants that we will further characterize with respect to AD. We will examine both Caucasian and Caribbean Hispanic AD populations. Our four pronged approach includes structural characterization at the DNA level (Dr. Pericak-Vance), analysis of Caribbean Hispanics (Dr. Richard Mayeux), functional characterization (Dr. Joseph Buxbaum), and pharmacological characterization (Dr. Jonathan Haines). Specifically, high priority RVs identified through the whole exome analysis will be further explored with multiple strategies. The most relevant is the investigation of their functional consequences to identify the most promising AD candidates. We will also sequence these candidate genes in a large sample of late-onset (LOAD) cases to examine their involvement in all AD. Finally, we will take the confirmed candidates and examine the effect of small molecule compounds on their expression to identify new potential targets for therapeutic intervention.					
15. SUBJECT TERMS none provided					
16. SECURITY CLASSIFICATION OF:			17. LIMITATION OF ABSTRACT	18. NUMBER OF PAGES	19a. NAME OF RESPONSIBLE PERSON
a. REPORT	b. ABSTRACT	c. THIS PAGE			19b. TELEPHONE NUMBER (include area code)
U	U	U	UU	30	USAMRMC

Table of Contents

	<u>Page</u>
Introduction.....	4
Body.....	5
Key Research Accomplishments.....	6
Reportable Outcomes.....	7
Conclusion.....	8
References.....	9
Appendices.....	10-26
Supporting Data.....	27-30

INTRODUCTION:

The primary focus toward identification of Alzheimer disease (AD) risk genes over the past five years has been testing the common disease common variant (CDCV) hypothesis through the use of genome-wide association studies (GWAS) in late onset Alzheimer disease (LOAD). While common variation clearly plays a role in AD there is a growing realization that the CDCV hypothesis is unlikely to explain all the genetic effect underlying AD. One alternative hypothesis invokes multiple rare variants (RV) in one or more genes, each with stronger individual effects than CDCV genes. We designed this project to test the rare variant hypothesis in AD by examining those cases with the most severe phenotype as determined by early onset (EOAD, cases with AAO < 60 years). Although there are three known EOAD genes (PS1, PS2 and APP) they account for only ~60-70% of familial EOAD and even less of sporadic EOAD. Thus, the majority of the genetics of EOAD remains unknown. Until now, large extended families with AD in multiple generations were necessary to identify variants of significant effect contributing to AD risk, however, with the advent of new genomic technologies such as high-throughput sequencing technology, small family aggregates and isolated cases, particularly those with an extreme phenotype of the disorder (such as early onset) can be used. Thus, we will utilize whole exome high-throughput sequencing to identify high risk AD variants that we will further characterize with respect to AD. We will examine both Caucasian and Caribbean Hispanic AD populations. Our four pronged approach includes structural characterization at the DNA level (Dr. Pericak-Vance), analysis of Caribbean Hispanics (Dr. Richard Mayeux), functional characterization (Dr. Joseph Buxbaum), and pharmacological characterization (Dr. Jonathan Haines). Specifically, high priority RVs identified through the whole exome analysis will be further explored with multiple strategies. The most relevant is the investigation of their functional consequences to identify the most promising AD candidates. We will also sequence these candidate genes in a large sample of late-onset (LOAD) cases to examine their involvement in all AD. Finally, we will take the confirmed candidates and examine the effect of small molecule compounds on their expression to identify new potential targets for therapeutic intervention.

BODY:

Whole exome sequencing (WES) has been completed on 55 familial Hispanic early onset samples submitted by Columbia University to the University of Miami Hussman Institute Center for Genome Technology. Variant calling and quality control processing of these samples is complete, and analysis of these samples has begun. Selection of early-onset cases for sequencing from the University of Miami and Vanderbilt University is complete and sequencing has begun on 50 Caucasian AD early onset affected individuals.

Additionally, we offer results of a pilot study of two early-onset AD families, 33525 (**Figure 1**) and 33839 (**Figure 2**). We conducted WES using Agilent SureSelect 50 Mb Human All Exon Kit to capture the exome (~1.5% of total genome). The sequencing was performed on Illumina HiSeq 2000, 3 indexed samples per flow cell lane, with 2x100 paired end runs.

Whole-exome sequencing high-quality read coverage at a read depth of >20x:

FAMILY ID	SAMPLE ID	AD affection status	% of exomic reads	Exome covered
33525	201000761	affected daughter	78.0%	86.0%
33525	201132990	unaffected daughter	79.9%	87.0%
33839	201209469	unaffected daughter	81.3%	86.0%
33839	201209470	affected son	82.5%	87.0%
33839	201209472	unaffected mother	87.0%	81.0%
33839	201241042	affected father	87.3%	83.0%

In table 1, we report the 10 and 8 variants/genes for family 33525 and 33839, respectively that are in concordance with an autosomal-dominant inheritance pattern, are novel (missing in public databases) and are predicted to be damaging for protein functioning. Of particular interest is a missense variant in the *LRP10* gene. All variants in table 1 are at phylogenetically conserved sites, are predicted to be protein-damaging and were absent in more than 11,000 control alleles from public databases. The particular variant in *LRP10* reached uniquely high conservation and deleteriousness scores (PhastCons=1, GERP=5.73, PholyPhen2 score=0.999). Moreover, it has been shown that disruption of *LRP10* protein functioning leads to increased APP secretion in human neuronal cell lines which is in line with AD etiology (*Brodeur et al Mol Neurodegener.* 2012) Pathogenic and potentially pathogenic SNVs in known early-onset AD genes such as APP, PSEN1, PSEN2, MAPT and GRN have been excluded. (Exonic bases in these genes with read depth less than 10 in WES data of the affected subject were re-sequenced by Sanger sequencing to exclude pathogenic variants).

We have now genotyped this *LRP10* variant in 1,000 AD cases and as many cognitively normal elderly controls and did not find any additional carriers. This confirms its extreme rarity suggested by public control data. We also examined this variant in the newly sequenced Columbia early-onset AD dataset and did neither detect carriers. Our conclusion is that this *LRP10* variant is an extremely rare and excellent candidate for EOAD based on function. We will screen for this variant in the additional sequence data as it is completed.

Using the same approach, we identified 8 potential candidates in family 33839 (**Table 1**). We will screen these candidates against the results of the sequencing of the Columbia and the Miami-Vanderbilt additional ~100 early-onset AD cases.

Identification and clinical characterization of the *MAPT* R406W mutation in an early onset AD family

The Arg406Trp (R406W) missense mutation in the microtubule associated protein-tau gene (*MAPT*) is a known cause of early-onset dementia (EOD). Various dementia phenotypes have been described, including frontotemporal dementia (FTD), FTD with Parkinsonism, and early-onset Alzheimer Disease (EOAD)-like presentations. Using whole exome capture with subsequent sequencing, we identified the R406W mutation in a family with multiple individuals with clinically diagnosed EOAD, in a pattern suggesting autosomal dominant inheritance (**Figure 3**). We clinically re-evaluated all available family members. Each of the affected individuals had a course meeting clinical criteria for EOAD. Two distinct disease trajectories were apparent: one rapidly progressive, and the other long and gradual (**Figure 4**). Four of five affected individuals also manifested Parkinsonian symptoms. FTD features were not prominent, and when present, appeared only late in the

course of dementia. The *MAPT* R406W mutation is associated with EOAD-like symptoms and Parkinsonism without FTD, as well as distinct cognitive courses.

KEY RESEARCH ACCOMPLISHMENTS:

- WES completed on samples of 55 Hispanic individuals submitted by Columbia
- Identification of *MAPT* R406W mutation to be associated with EOAD-like symptoms (Carney et al)
- 10 and 8 potentially damaging segregating candidates in pilot EOAD sibling pairs.
- A missense variant in the *LRP10* gene is an extremely rare, excellent candidate for EOAD based on *LRP10* function involved in APP secretion.

REPORTABLE OUTCOMES:

Carney RM, Kohli MA, Kunkle BW, Naj AC, Gilbert JR, Züchner S, **PERICAK-VANCE MA**, Parkinsonism and distinct dementia patterns in a family with the MAPT R406W mutation. *Alzheimers Dement.* Provisionally In Press, April 2013.

CONCLUSION:

Whole-exome sequencing in three Caucasian EOAD families as a pilot study clearly showed that this is a promising approach to unravel novel EOAD genes. In one family, we have identified the *MAPT* R406W variant as cause of an EOAD-like symptom. In essence, this finding corroborates the EOAD-like phenotype that has previously been related to this genetic variant as part of its broader phenotypic spectrum of early-onset dementia. For the other two pilot families we only sequenced sibling pairs. Nevertheless, we were able to reduce the catalogue of resulting novel EOAD candidate variants to only 8 and 10 variants, respectively. Among them is a novel, damaging variant in the *LRP10* gene. It has been shown that disruption of the *LRP10* protein leads to increased *APP* secretion in human cells. This is in line with increased AD risk. Moreover, we completed whole-exome sequencing in 55 EOAD family subjects from the Columbia dataset. Analyses of these larger collective will likely enable even more conclusive results and validation of herein mentioned candidates from the pilot study.

REFERENCES:

Brodeur J, Thériault C, Lessard-Beaudoin M, Marcil A, Dahan S, Lavoie C. LDLR-related protein 10 (LRP10) regulates amyloid precursor protein (APP) trafficking and processing: evidence for a role in Alzheimer's disease. *Mol Neurodegener.* 2012 Jun 26;7:31. PMID: 22734645[PubMed - in process]

Carney RM, Kohli MA, Kunkle BW, Naj AC, Gilbert JR, Züchner S, **PERICAK-VANCE MA**, Parkinsonism and distinct dementia patterns in a family with the MAPT R406W mutation. *Alzheimers Dement.* Provisionally In Press, April 2013.

APPENDICES:

APPENDIX 1

Carney RM, Kohli MA, Kunkle BW, Naj AC, Gilbert JR, Züchner S, **PERICAK-VANCE MA**, Parkinsonism and distinct dementia patterns in a family with the MAPT R406W mutation. *Alzheimers Dement.* Provisionally In Press, April 2013.

APPENDIX 2

Research Article

Parkinsonism and distinct dementia patterns in a family with the MAPT R406W mutation

Regina M. Carney¹, Martin A. Kohli¹, Brian W. Kunkle¹, Adam C. Naj¹, John R. Gilbert^{1,2}, Stephan Züchner^{1,2},
Margaret A. Pericak-Vance^{1,2}

1) University of Miami, Miller School of Medicine, John P. Hussman Institute for Human Genomics, Miami, FL, 33136, USA. 2) University of Miami, Miller School of Medicine, Dr. John T. Macdonald Foundation Department of Human Genetics, Miami, FL, 33136, USA.

Corresponding Author:

Dr. Margaret A Pericak-Vance

University of Miami Miller School of Medicine

John P. Hussman Institute for Human Genomics

1501 NW 10th Avenue

Biomedical Research Building, Room 318

Miami, FL 33136

Office: (305) 243-2308

Fax: (305) 243-1968

mpericak@med.miami.edu

Abstract

Background

The Arg406Trp (R406W) missense mutation in the microtubule associated protein-tau gene (*MAPT*) is a known cause of early-onset dementia (EOD). Various dementia phenotypes have been described, including frontotemporal dementia (FTD), FTD with Parkinsonism, and early-onset Alzheimer Disease (EOAD)-like presentations.

Methods

Using whole exome capture with subsequent sequencing, we identified the R406W mutation in a family with multiple individuals with clinically diagnosed EOAD, in a pattern suggesting autosomal dominant inheritance. We clinically re-evaluated all available family members.

Results

Each of the affected individuals had a course meeting clinical criteria for EOAD. Two distinct disease trajectories were apparent: one rapidly progressive, and the other long and gradual. Four of five affected individuals also manifested Parkinsonian symptoms. FTD features were not prominent, and when present, appeared only late in the course of dementia.

Conclusions

The *MAPT* R406W mutation is associated with EOAD-like symptoms and Parkinsonism without FTD, as well as distinct cognitive courses.

Keywords: microtubule associated protein-tau, dementia, early onset Alzheimer's disease, frontotemporal dementia, whole exome sequencing

1. Introduction

Early-onset dementia (EOD) is defined by memory and cognitive difficulties beginning before age 65, and commonly occurs in a familial pattern. EOD can be divided into presenile dementias, such as frontotemporal dementia (FTD), and senile dementias with early onset (such as early-onset Alzheimer's Disease, or EOAD)¹. The presence of characteristic symptoms guides the diagnosis of early-onset dementia, however due to varied phenotypic expression and frequently overlapping symptoms, the exact diagnosis may not be distinguished without neuropathologic examination².

Genetic investigations have revealed causative mutations for several EOD syndromes. In the case of EOAD, mutations in the *APP*³, *PSEN1*⁴, and *PSEN2*⁵ genes have been pinpointed. Another gene implicated in EOD is the microtubule associated protein-tau (*MAPT*)⁶. The Arg406Trp (R406W) missense mutation in *MAPT* has been associated with various EOD phenotypes including FTD⁷⁻¹²; an illness clinically resembling early-onset (EOAD) with later onset of frontal signs¹³⁻¹⁶; and rapidly-progressing dementia with psychosis¹⁷. Parkinsonian features are infrequently present^{7,12}.

We identified the R406W mutation in a family with multiple individuals with EOD that was clinically indistinguishable from EOAD. The disease occurred in several generations suggesting autosomal dominant inheritance. In order to further elucidate the neuropsychiatric phenotype associated with the mutation, we clinically re-evaluated all available members of the family, updating and confirming evolving clinical signs and symptoms. Each of the clinically affected individuals had a course meeting clinical criteria for EOAD. Two distinct disease trajectories were apparent: one rapidly progressive, and the other following a gradual and long course. Four of five individuals with memory loss also manifested Parkinsonian symptoms. FTD features were not prominent, and when present, appeared only late in the course of dementia.

2. Methods

2.1 Family and clinical data

The family was identified as part of our ongoing genetic studies in dementia. Participants were recruited, enrolled, and sampled according to the Institutional Review Board protocols for the University of Miami. A complete description of the study was provided to the subjects, and written informed consent was obtained. Whole blood was collected from all participants by venipuncture. Affection status was determined by

consensus of physicians and clinical staff experienced in clinical dementia research and based on medical records and in-person evaluation. All affected subjects all met NINCDS-ADRDA criteria for the diagnosis of Alzheimer's Disease (AD). Age of onset (AOO) was estimated as date of first onset of symptoms as reported by the patient, their informant, or abstracted from the patient's medical records.

All living participants in the family were clinically re-assessed in person following identification of the R406W mutation. Direct evaluation included a neurological examination and neuropsychological measures. Medical records and research study data were reviewed, including serial physical and neurological examinations, history by family report, cognitive assessments, and instruments assessing symptom domains such as functional impairments, depression, and psychosis. The age of enrollment (AOE) is age at which the participant joined the research study. Data on neuropathology and biomarkers such as tau and β -amyloid were not available.

2.2 Molecular analysis

Whole-exome sequencing was performed as part of the research study. Whole blood derived DNA samples of five affected individuals from the family were subjected to whole exome capture using the Sure Select Human All Exon 50 Mb protocol from Agilent Technologies with subsequent sequencing library preparation for massive parallel sequencing on a HiSeq2000 instrument from Illumina. Sequence read alignment and variant calling was performed by applying the BWA/GATK software¹⁸. Variants were filtered to be (1) heterozygous in all five individuals assuming autosomal-dominant inheritance, (2) falling in regions of 100% sharing by identity-of-descent (IBD) previously calculated from genome-wide SNP genotyping data in this family, (3) to be most likely to interfere with protein function (missense, nonsense and splice site changes) (4) in established EOAD genes (*amyloid precursor protein (APP)*, *presenilin 1 (PSEN1)*, *presenilin 2 (PSEN2)*) and EOD genes (*microtubule-associated protein tau (MAPT)*, and *granulin (PGRN)*¹⁹). Passed filtering variants were validated by Sanger sequencing in five affected and three unaffected family members (two were married-in) with DNA samples available.

APOE-ε genotypes²⁰, *MAPT* H1/H2 haplotypes^{21,22}, and *C9ORF72* repeat expansions^{23,24} have each been shown to contribute to AD risk, phenotypic expression, and/or clinical course of EOD and thus were also examined. Apolipoprotein E (*APOE-ε*) genotype data were available on all participants and were determined as previously described²⁵. For the *MAPT* H1/H2 haplotype data, SNP rs17650901 was used. This SNP is in perfect linkage disequilibrium with rs1800547, ($r^2=1.0$), which has been previously used to distinguish the

H1/H2 haplotypes²⁶. *MAPT* H1/H2 data were available only on affected, sampled individuals (4, 6, 8, 13, 14). The *C9ORF72* repeat copy count was available for affected individuals 4, 6, 8, and 13. Moreover, for all related, sampled individuals in the family (individuals 4, 6, 8, 13, 14, and 15), whole exome data was carefully screened for reported clinical and potentially damaging variants in the following genes related to either dementia and/or Parkinsonism: *SNCA*²⁷, *LRRK2*²⁸, *PRKN*²⁹, *DJ1*³⁰, *PINK1*³¹, and *SORL1*³².

3. Results

3.1 Molecular

Molecular applied filtering criteria on whole exome sequencing data exclusively identified the R406W mutation (rs63750424 – C/T) in *MAPT* among the screened early-onset AD genes. Heterozygosity for the R406W mutation was confirmed by Sanger sequencing for all five affected family members with DNA available (4, 6, 8, 13, and 14) as well as one unaffected sampled family member (15). Two married-in spouses (3 and 7), both unaffected, did not carry the mutation.

APOE-ε status was 3/4 for individuals 4 and 13. All other sampled individuals carried the 3/3 genotype. *MAPT* haplotype status was H1/H1 for all sampled, affected individuals. *C9ORF72* sequencing in individuals 4, 6, 8, and 13 revealed a repeat copy count within non-pathogenic range (<30; range: 3-19). No reported clinical or potentially disease-modifying variants in the genes *SNCA*, *LRRK2*, *PRKN*, *DJ1*, *PINK1*, and *SORL1* were detected in this family's whole exome sequencing data.

3.2 Clinical

3.2.1 Overall trends

The pedigree is shown in Figure 1. The pedigree has been altered to protect the identity of the participants. Each of the five affected individuals with DNA available (4, 6, 8, 13, 14) presented with early-onset dementia (range: 48-62 years old). The initial course followed a typical AD pattern, with early forgetfulness, progressive worsening in several areas of cognitive function (for example, short-term memory loss and difficulties with orientation) or activities of daily living, and difficulties with language³³. As the disease progressed, two distinct cognitive trajectories were identified, as measured by the Mini Mental Status Examination (³⁴; see Figure 2). Individuals 6 and 13 manifested a relatively rapid deterioration, while a more benign progression with evidence of long disease duration was seen in individuals 4, 8, and 14.

In addition, four of the five affected individuals developed Parkinsonian symptoms as the course of dementia continued (see Supplemental Table 1). The onset and severity of Parkinsonian symptoms ranged from comorbid Parkinson Disease (PD) with onset of symptoms <5 years into the disease course, to mild Parkinsonian symptoms 16 years after the initial diagnosis of dementia. Symptoms such as early personality, behavior, or language changes, were not present. Later in the course, two individuals showed frontal release signs.

3.2.2 Specific clinical features

The proband, individual 4, had short-term memory loss and calculation difficulties beginning at age 56, and was diagnosed with EOAD. No Parkinsonism, affective symptoms or behavioral changes were present early in disease. Slow functional decline followed, primarily affecting memory and orientation. Language difficulties did not predominate. The participant enrolled in our research study after 13 years of illness, and a research diagnosis of probable AD was assigned. After 16 years of illness, the individual showed abnormal facial expression, bradykinesia, and abnormal speech. Exam at 23 years of disease duration revealed severe dementia with aphasia, Parkinsonism (action and rest tremor, rigidity, flat affect, cogwheeling, and bradykinesia), and frontal release signs (snout, palmomental, grasp reflexes). Her medical history is significant for depression and an operative procedure after >15 years disease duration. Common medical risk factors for dementia (e.g., cardiac or cerebrovascular disease, stroke, diabetes, hypertension) were not present on history or imaging.

Individual 6 was clinically diagnosed at 59 years old with EOAD, with symptoms of withdrawal and difficulty adapting to new environments. There was a remote (>30 year) history of several surgeries requiring general anesthesia. Otherwise, the individual was healthy. Symptoms of PD appeared within the first 5 years of illness (flat affect and slow, shuffling gait). PD features progressed to include cogwheel rigidity, hunched posture, and dysphagia, which were responsive to l-methyldopa. Cognition rapidly declined and the individual was completely aphasic after 7 years. Death occurred after 11 years of illness with clinical and research diagnoses of AD and PD. No autopsy was performed.

Individual 8's clinical course reflected memory difficulties with preserved function for many years. A slight tremor was noted at 15 years of illness. Reassessment at 22 years of illness revealed significant aphasia with mild Parkinsonian features of tremor, masked faces, and slight cogwheeling. Frontal exam was normal. In terms of medical comorbidities, individual 8 had a few risk factors for vascular disease but no evidence of

vascular disease.

Individual 13 experienced the earliest AOO (48 years). A typical dementing pattern, including getting lost and word-finding difficulties, developed but progressed rapidly. Subtle personality changes, including inappropriate joking and disinhibition, appeared 5 years after the onset of memory difficulties. Individual 13 died suddenly 6 years after disease onset. No Parkinsonian features were noted throughout the course, and the individual's medical history was largely unremarkable.

Individual 14's mild cognitive impairment progressed to amnesia for faces and names at age 58. Depression and anxiety developed without personality or behavioral changes. Exam at 7 years disease duration showed very mild asymmetric cogwheeling and slightly hunched posture, with no frontal findings. Individual 14 is in excellent health.

The unaffected family member carrying the mutation (individual 15) demonstrated an unremarkable neurological exam, within no Parkinsonian or frontal features. Despite complaints of difficulty remembering a short list, there was no evidence of functional impairments. Neuropsychological exam revealed mild difficulty with delayed recall and naming politicians.

Individuals 3 and 7 were married-in spouses. Their unaffected status was confirmed by history, neuropsychological testing, and assessments of daily function.

4. Discussion

The presence of the *MAPT* R406W mutation in all affected individuals supports the previously reported association with EOD, and in this case, the phenotype was clinically indistinguishable from EOAD. Generally, published descriptions of individuals with the R406W mutation describe a slowly progressive dementia, with symptoms of frontal dysfunction, but lacking Parkinsonism (see Supplemental Table 2). In contrast to these studies, 4 of the 5 affected individuals carrying the *MAPT* R406W in this family demonstrated Parkinsonian features. The affected individuals did not demonstrate initial frontal signs or symptoms.

Additional early-onset dementias with Parkinsonism exist (reviewed in ³⁵). These include frontotemporal dementia linked to Parkinsonism (FTDP-17), dementia with Lewy Bodies (DLB), progressive supranuclear palsy (PSP), and corticobasal degeneration (CBD). In contrast, mutations in the EOAD genes, *amyloid-beta precursor protein (APP)*, *presenilin 1 and 2 (PSEN1, PSEN2)* are not typically associated with Parkinsonism.

The dementia of FTDP-17 may resemble that of DLB or AD, with motor symptoms including tremor, rigidity, and bradykinesia, and occasionally psychiatric features (hallucinations, delusions). A variety of mutations in *MAPT* are causative for FTDP-17. Indeed, the reports on two other families with both the *MAPT* R406W mutation and Parkinsonism (see Supplemental Table 2) indicate that the diagnosis may be FTDP-17 rather than FTD^{7,8,12,36}.

Unlike AD, marked fluctuations in cognition are seen in DLB, and the presence of recurrent visual hallucinations is a hallmark of the illness³⁷. Parkinsonian features are often more prominent than cognitive degeneration, particularly at disease onset.

Phenotypic variants of PSP include a presentation with PD-like bradykinesia and rigidity³⁸. CBD features include basal ganglia dysfunction (akinesia, postural instability, and tremor) and cortical deficits (alien hand syndrome, apraxia, sensory impairments, aphasia, or dementia)³⁹.

In the *MAPT* R406W mutation, the course of dementia in published descriptions is generally slowly progressive, with gradual functional declines. The serial cognitive exam scores in this family demonstrate two distinct courses of cognitive decline. One is slowly progressive and indolent, similar to previous reports. The other is more rapid and severe. We were unable to identify a simple explanation for this variance. There is no clear association between presence, severity, or AOO of Parkinsonian features and the trajectory of cognitive decline. We did not identify a correlation between co-occurring conditions (stroke, vascular disease, diabetes, exposure to general anesthesia) and the rate of cognitive decline. The *APOE-ε* genotype, *MAPT* H1/H2 haplotype, and *C9ORF72* repeat copy number status did not account for the variance in the rates of cognitive decline. The two individuals, both affected, who carry the *APOE-ε* 3/4 genotype are discordant for disease course, and *MAPT* haplotypes were identical (H1/H1) in all affected individuals. A pathogenic expansion of the *C9ORF72* gene was not detected. Potentially damaging variants were not found in the following genes related to dementia and/or Parkinsonism: *SNCA*, *LRRK2*, *PRKN*, *DJ1*, *PINK1*, and *SORL1*.

One individual (15) who carries the mutation is unaffected at this time. This individual's current age is less than the age of the latest reported AOO in this family (48-62 years). Continued follow-up examinations are necessary to reveal whether the current complaints of mild memory loss represent early manifestations of EOD, or a more benign process.

An important limitation of the study is the lack of neuropathology data. Diagnosis based on clinical criteria classifies the affected individuals in the currently reported family carrying the *MAP-T* R406W mutation

as EOAD, a phenotype that has been previously described¹³⁻¹⁶. We do not have pathology results for this family. However, neuropathological results are available for individuals in other families carrying the *MAPT* R406W mutation. Regardless of clinical presentation, neuropathology on all individuals carrying this mutation has been uniformly consistent with a diagnosis of FTD. Thus, if tissue were available to be examined, it is possible that the family described in the current report might demonstrate neuropathologic features consistent with a FTD diagnosis. Interestingly, a recent report states that rarely, despite evaluation at a specialty clinic for early-onset dementia, some cases of clinically diagnosed FTD met neuropathologic criteria for Alzheimer's Disease instead⁴⁰.

5. Conclusions

Whole exome sequencing successfully identified the R406W mutation in the *MAPT* gene in individuals affected with EOAD-like symptoms in a single family. Clinical characterization of these individuals reveals an association with Parkinsonism, a lack of association with early frontal dysfunction, and two distinct cognitive courses. Neither co-occurring illnesses nor variant status in EOD- or Parkinsonism-associated genes were correlated with rate of cognitive decline. These data both confirm previous genetic associations and enhance the available data on phenotypes associated with the mutation in *MAPT*. Variability in phenotype, even with the same mutation, may indicate other genetic or environmental factors contribute to disease.

Acknowledgements

We are grateful to the families and staff who participated in this study. This work was supported by National Institute of Health grants R01 AG027944 (MPV), U01AG032984 (MPV), the Alzheimer's Association grant IIRG09133827 (MPV), the American Health Assistance Foundation grant A2011048 (MPV) and a grant from the U.S. Department of Defense W81XWH-12-1-0013 (MPV).

BIBLIOGRAPHY

1. Miyoshi K. What is 'early onset dementia'? *Psychogeriatrics*. 2009;9(2):67-72.
2. Khachaturian ZS. Diagnosis of Alzheimer's Disease. *Arch Neurol* 1985;42(11):1097-1105.
3. Goate A, Chartier-Harlin M, Mullan M, Brown J, Crawford F, Fidani L, et al. Segregation of a missense mutation in the amyloid precursor protein gene with familial Alzheimer's disease. *Nature* 1991;349:704-706.
4. Sherrington R, Rogaev EI, Liang Y, Rogaeva EA, Levasque G, Ikeda M, et al. Cloning of a gene bearing mis-sense mutations in early-onset familial Alzheimer's disease. *Nature* 1995;375:754-760.
5. Rogaev EI, Sherrington R, Rogaeva EA, Levesque G, Ikeda M, Liang Y, et al. Familial Alzheimer's disease in kindreds with missense mutations in a gene on chromosome 1 related to the Alzheimer's disease type 3 gene. *Nature* 1995;376:775-778.
6. Hong M, Zhukareva V, Vogelsberg-Ragaglia V, Wszolek Z, Reed L, Miller BI, et al. Mutation-specific functional impairments in distinct Tau isoforms of hereditary FTDP-17. *Science* 1998;539:1914-1917.
7. Reed LA, Grabowski TJ, Schmidt ML, Morris JC, Goate A, Solodkin A, et al. Autosomal dominant dementia with widespread neurofibrillary tangles. *Ann Neurol* 1997;4:564-572.
8. Hutton M, Lendon CL, Rizzu P, Baker M, Froelich S, Houlden H, et al. Association of missense and 5'-splice-site mutations in tau with the inherited dementia FTDP-17. *Nature* 1998;393:702-705.
9. Rosso SM, Donker Kaat L, Baks T, Joosse M, de Koning I, Pijnenburg Y, et al. Frontotemporal dementia in The Netherlands: patient characteristics and prevalence estimates from a population-based study. *Brain* 2003;9:2016-2022.
10. Passant U, Ostojic J, Froelich Fabre S, Gustafson L, Lannfelt L, Larsson EM, et al. Familial presenile dementia with bitemporal atrophy. *Dement Geriatr Cogn Disord* 2004;4:287-292.
11. Ostojic J, Elfgren C, Passant U, Nilsson K, Gustafson L, Lannfelt L, et al. The tau R406W mutation causes progressive presenile dementia with bitemporal atrophy. *Dement Geriatr Cogn Disord* 2004;4:298-301.
12. van Swieten JC, Stevens M, Rosso SM, Rizzu P, Joosse M, de Koning I, et al. Phenotypic variation in hereditary frontotemporal dementia with tau mutations. *Ann Neurol* 1999;4:617-626.

13. Rademakers R, Dermaut B, Peeters K, Cruts M, Heutink P, Goate A, et al. Tau (MAPT) mutation Arg406Trp presenting clinically with Alzheimer disease does not share a common founder in Western Europe. *Hum Mutat* 2003;5:409-411.
14. Lindquist SG, Holm IE, Schwartz M, Law I, Stokholm J, Batbayli M, et al. Alzheimer disease-like clinical phenotype in a family with FTDP-17 caused by a MAPT R406W mutation. *Eur J Neurol* 2008;15(4):377-385.
15. Lindquist SG, Schwartz M, Batbayli M, Waldemar G, Nielsen JE. Genetic testing in familial AD and FTD: mutation and phenotype spectrum in a Danish cohort. *Clin Genet* 2009;2:205-209.
16. Ikeuchi T, Kaneko H, Miyashita A, Nozaki H, Kasuga K, Tsukie T, et al. Mutational analysis in early-onset familial dementia in the Japanese population. The role of PSEN1 and MAPT R406W mutations. *Dement Geriatr Cogn Disord* 2008;1:43-49.
17. Saito Y, Geyer A, Sasaki R, Kuzuhara S, Nanba E, Miyasaka T, et al. Early-onset, rapidly progressive familial tauopathy with R406W mutation. *Neurology* 2002;5:811-813.
18. McKenna A, Hanna M, Banks E, Sivachenko A, Cibulskis K, Kernytsky A, et al. The Genome Analysis Toolkit: a MapReduce framework for analyzing next-generation DNA sequencing data. *Genome Res* 2010;9:1297-1303.
19. Cruts M, Theuns J, Van Broeckhoven C. Locus-specific mutation databases for neurodegenerative brain diseases. *Hum Mutat* 2012;33(9):1340-1344.
20. Corder EH, Saunders AM, Strittmatter WJ, Schmechel DE, Gaskell PC, Small GW, et al. Gene dose of apolipoprotein E type 4 allele and the risk of Alzheimer's disease in late onset families. *Science* 1993;261(5123):921-923.
21. Baker M, Litvan I, Houlden H, Adamson J, Dickson D, Perez-Tur J, et al. Association of an extended haplotype in the tau gene with progressive supranuclear palsy. *Hum Mol Genet* 1999;8(4):711-715.
22. Cruts M, Rademakers R, Gijselinck I, van der Zee J, Dermaut B, de Pooter T, et al. Genomic architecture of human 17q21 linked to frontotemporal dementia uncovers a highly homologous family of low-copy repeats in the tau region. *Hum Mol Genet* 2005;14(13):1753-1762.
23. Kohli MA, John-Williams K, Rajbhandary R, Naj A, Whitehead P, Hamilton K, et al. Repeat expansions in

the C9ORF72 gene contribute to Alzheimer's disease in Caucasians. *Neurobiol Aging*. 2012;S0197-4580(12)00493-9.

24. DeJesus-Hernandez M, Mackenzie IR, Boeve BF, Boxer AL, Baker M, Rutherford NJ, et al. Expanded GGGGCC hexanucleotide repeat in noncoding region of C9ORF72 causes chromosome 9p-linked FTD and ALS. *Neuron* 2011;72(2):245-256.

25. Naj AC, Jun G, Beecham GW, Wang LS, Vardarajan BN, Buross J, et al. Common variants at MS4A4/MS4A6E, CD2AP, CD33 and EPHA1 are associated with late-onset Alzheimer's disease. *Nature Genet* 2011;43(5):436-441.

26. Zabetian CP, Hutter CM, Factor SA, Nutt JG, Higgins DS, Griffith A, et al. Association analysis of MAPT H1 haplotype and subhaplotypes in Parkinson's disease. *Ann Neurol* 2007;62(2):137-144.

27. Singleton AB, Farrer M, Johnson J, Singleton A, Hague S, Kachergus J, et al. α -Synuclein Locus Triplication Causes Parkinson's Disease. *Science* 2003;302:841.

28. Dächsel JC, Farrer MJ. LRRK2 and Parkinson Disease. *Arch Neurol* 2010;67(5):542-547.

29. Kitada T, Asakawa S, Hattori N, Matsumine H, Yamamura Y, Minoshima S, et al. Mutations in the parkin gene cause autosomal recessive juvenile parkinsonism. *Nature* 1998;392(6676): 605–608.

30. Bonifati V, Rizzu P, van Baren MJ, Schaap O, Breedveld GJ, Krieger E, et al. Mutations in the DJ-1 gene associated with autosomal recessive early-onset parkinsonism. *Science* 2003;299:256-259.

31. Valente EM, Salvi S, Ialongo T, Marongiu R, Elia AE, Caputo V, et al. PINK1 mutations are associated with sporadic early-onset parkinsonism. *Ann Neurol* 1998;56(3):336–341.

32. Rogaeva E, Meng Y, Lee JH, Gu Y, Kawarai T, Zou F, et al. The neuronal sortilin-related receptor SORL1 is genetically associated with Alzheimer disease. *Nat Genet* 2007;39(2):168-177.

33. McKhann G, Drachman D, Folstein M. Clinical diagnosis of Alzheimer's disease: Report of the NINCDS-ADRDA Work Group under the auspices of the Department of Health and Human Services Task Force on Alzheimer's Disease. *Neurology* 1984;34(7):939-944.

34. Folstein MF, Folstein SE, McHugh PR. "Mini-mental state". A practical method for grading the cognitive state of patients for the clinician. *J Psychiatr Res* 1975;3:189-198.

35. Ludolph AC, Kassubek J, Landwehrmeyer BG, Mandelkow E, Mandelkow E-M, Burn DJ et al. Tauopathies with parkinsonism: clinical spectrum, neuropathologic basis, biological markers, and treatment options. *Eur J Neurol* 2009;16(3):297–309.
36. Foster NL, Wilhelmsen K, Sima AA, Jones MZ, D'Amato CJ, Gilman S. Frontotemporal dementia and parkinsonism linked to chromosome 17: a consensus conference. Conference Participants. *Ann Neurol* 1997;41:706–715.
37. Taipa R, Pinho J, Melo-Pires M. Clinico-pathological correlations of the most common neurodegenerative dementias. *Front Neurol* 2012;3(68):1-13.
38. Litvan I, Agid Y, Calne D, Campbell G, Dubois B, Duvoisin RC, et al. Clinical research criteria for the diagnosis of progressive supranuclear palsy (Steele-Richardson-Olszewski syndrome): report of the NINDS-SPSP international workshop. *Neurology*. 1996;47(1):1-9.
39. Belfor N, Amici S, Boxer AL, Kramer JH, Gorno-Tempini ML, Rosen HJ, et al. Clinical and neuropsychological features of corticobasal degeneration. *Mech Ageing Dev* 2006;127:203-207.
40. Snowden JS, Thompson JC, Stopford CL, Richardson AM, Gerhard A, Neary D, et al. The clinical diagnosis of early-onset dementias: diagnostic accuracy and clinicopathological relationships. *Brain* 2011;134(9):2478-2492.

Figure 1: Family pedigree

Figure 2: Progression of cognitive change in affected individuals

Supplemental Table 1: Clinical characteristics of affected individuals

Supplemental Table 2: Phenotypic description of individuals in families with the MAPT R406W mutation

Legend





-  Early Onset Dementia
-  Clinical Status Unknown
-  R4O6W Known Carrier
-  DNA Available for Testing
- AOO = Age Of Onset
- AOE = Age Of Enrollment

Figure 1: Family Pedigree

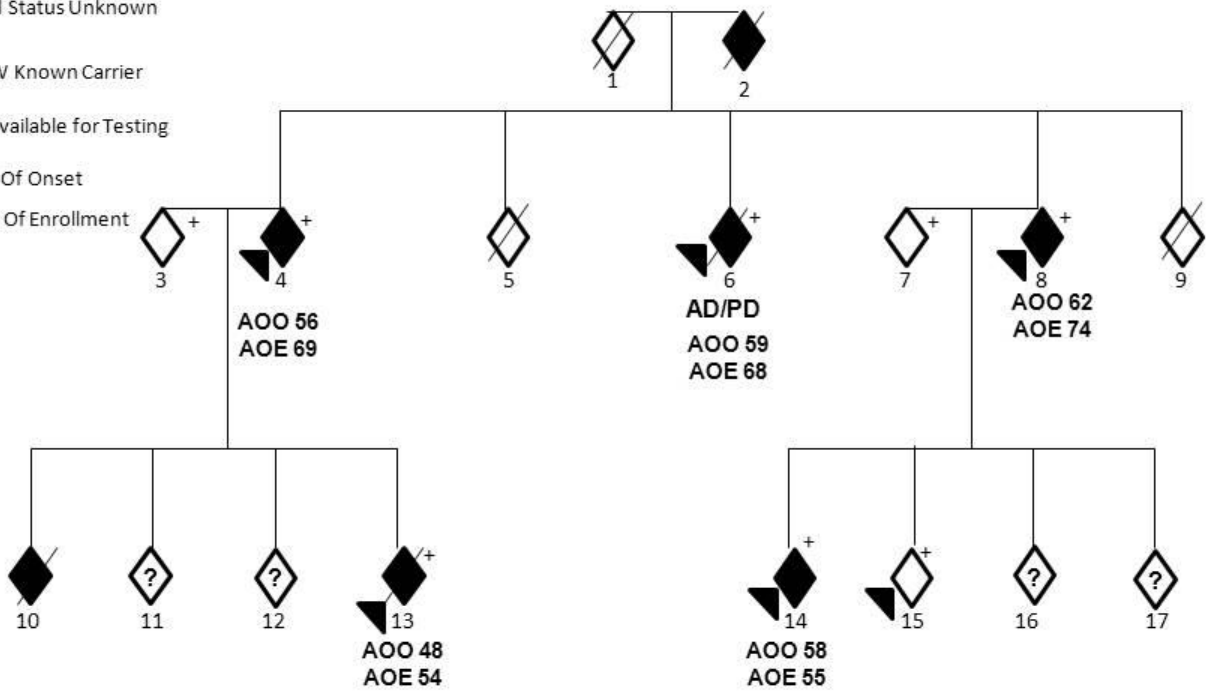
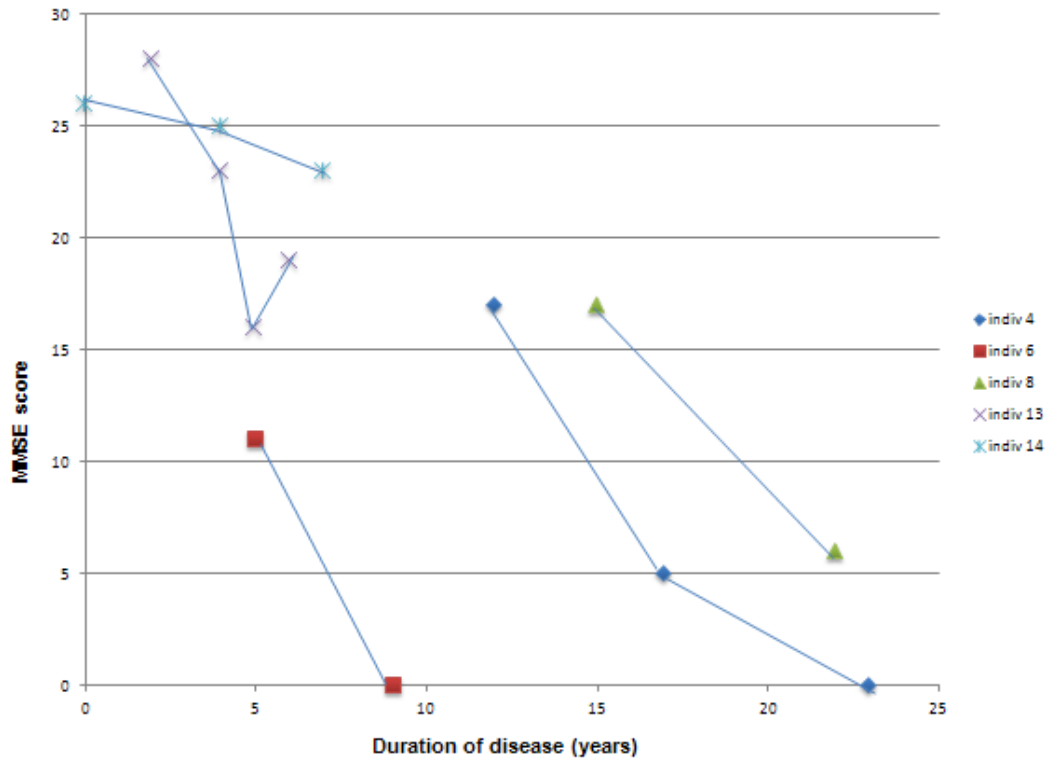

Figure 2: Progression of cognitive change in affected individuals



Supplemental Table 1. Clinical characteristics of affected individuals					Features of frontotemporal dementia (FTD)				Signs and Symptoms of Parkinsonism
Individual Number	Clinical Diagnosis	Age of onset	Duration of disease	Duration of disease at onset of Parkinsonian features	Behavior Changes	Personality Changes	Language Changes	Frontal Release Signs	
4	probable AD	56	23	16	-	-	+(later)	+(later)	+(later, severe)
6	probable AD, PD	59	11	<5	-	-	+(later)	-	+(PD diagnosis)
8	probable AD	62	22	15	-	-	+(later)	-	+(later, mild)
13	probable AD	48	6	n/a	+(later)	+(later)	-	-	-
14	probable AD	58	8	7	-	-	+(later)	-	+(very mild)

Abbreviations: AD, Alzheimer's Disease; PD, Parkinson Disease.

Supplemental Table 2. Phenotypic description of individuals in families with the MAPT R406W mutation

Citation	Clinical Diagnoses	Number of R406W + individuals	Average age of onset (years)*	Range of age of onset (years)*	Duration of illness (years)^	Signs or symptoms of frontal dysfunction		Signs and Symptoms of Parkinsonism
						Early Onset	Late Onset	
current report	EOAD/PD; EOAD	6 (1 unaffected)	57	48-62	6-23; 14	-	+	+
Reed 1997, Hutton 1998	FTDP-17	4	55	45-75	21-35	+	+	+
van Swieten 1999	FTD	3	59	53-65	11-17; 12.7	+	+	+
Saito 2002	EOD ("primary degenerative dementia")	1	54	47-60	6	+	+	n/a
Rademakers 2003	AD; unspecified dementia (both with later frontal signs)	4	58	54-65	7-22; 13.7	-	+	n/a
Rosso 2003	FTD	4 (2 families)	55	51-58	13-19	+	n/a	n/a
Ostojic 2004, Passant 2004	FTD ("familial progressive presenile dementia")	4	58	54-62	5-23	+	+	-
Lindquist 2008, 2009	AD/FTD	4 (1 unaffected)	61	52-65	n/a	-	+	n/a
Ikeuchi 2008	AD	3 (2 families)	52	45-56	10-17	-	+	n/a

Abbreviations: EOAD, early onset Alzheimer's Disease; PD, Parkinson Disease; FTDP-17, frontotemporal dementia and parkinsonism linked to chromosome 17; FTD, frontotemporal dementia; EOD, early onset dementia; +, present; -, absent; n/a, not available.

* May include affected individuals who were not tested for the R406W mutation

^ Duration is given as a range and/or average (as reported), which may include affected individuals still living, or multiple families

SUPPORTING DATA:

Figure 1

IHG 33525

Legend
AOO
AOE
APOE

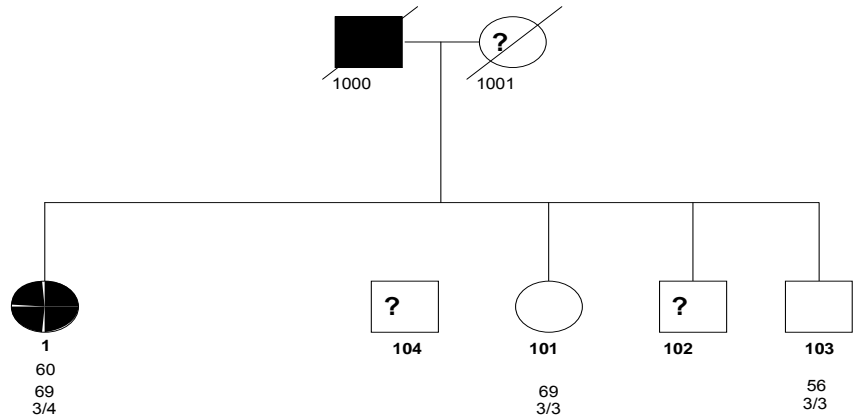

Figure 2

IHG 33839

Legend
AOO
AOE
APOE

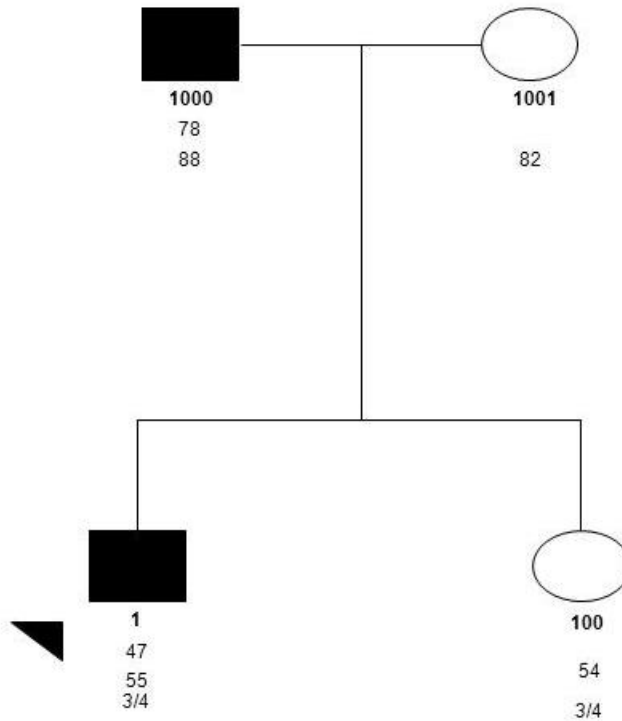

Table 1.

WHOLE-EXOME SEQUENCING IN 2 HIHG EARLY-ONSET AD DISCORDANT SIB. PAIRS: NOVEL, DAMAGING, VARIANTS UNIQUE TO AFFECTED SUBJECT				
Variant filtering under a autosomal-dominant inheritance model	FAM.33525 # SNVs	FAM.33839 # SNVs	FAM.33525, genes	FAM.33839, genes
Number of AD discordant sibling pairs / parents subjected to WES	1/0	1/1		
(1) - Missense, nonsense, in-frame indels, frame-shift indels, splice site - MAF<5% (NHLBI ESP6500 AA,AE & dbSNP135) or unkown - affected heterozygous & unaffected wildtype or n/a - GQ + QUAL > 50 - Read depth ≥6 - VQSLOD score ≥0	545	775		
(2A) SNPs (3A) MAF=0 or no freq. in NHLBI ESP6500 and dbSNP135 (4A) Unique in HIHG WES control data ~ (5A) Phylogenetically conserved (GERP>3)	413	360		
	337	312		
	33	28		
	19	26		
	12	21		
(6A) Protein-damaging (Polyphen2: D,P,unknown)	9* [^]	7 [^]	AKAP2, BMP4, C19orf6, CYB5RL, FOXA1, FREM3, LRP10, SPERT, USE1	DAPK1, GYLTL1B, HMX1, NT5M, PKD1, SLC44A3, ZKSCAN5
(7A) ALZ or PDGene	1* [^]	1 [^]	CYB5RL (PD genes)	DAPK1 (AD gene)
(3B) INDELS (4B) Unique in HIHG WES control data ~ (+ No public freq. data)	76	46		
	1	1	NAA25	PDE4DIP
(7B) ALZ or PDGene	0	0		
TOTAL OF NOVEL, DAMAGING, AFFECTED-UNIQUE SNVs (6A+4B)	10*[^]	8[^]	10 genes	8 genes
~ 1239 unrelated non-AD control exomes, * Sanger sequencing validated, [^] predicted to be most damaging				

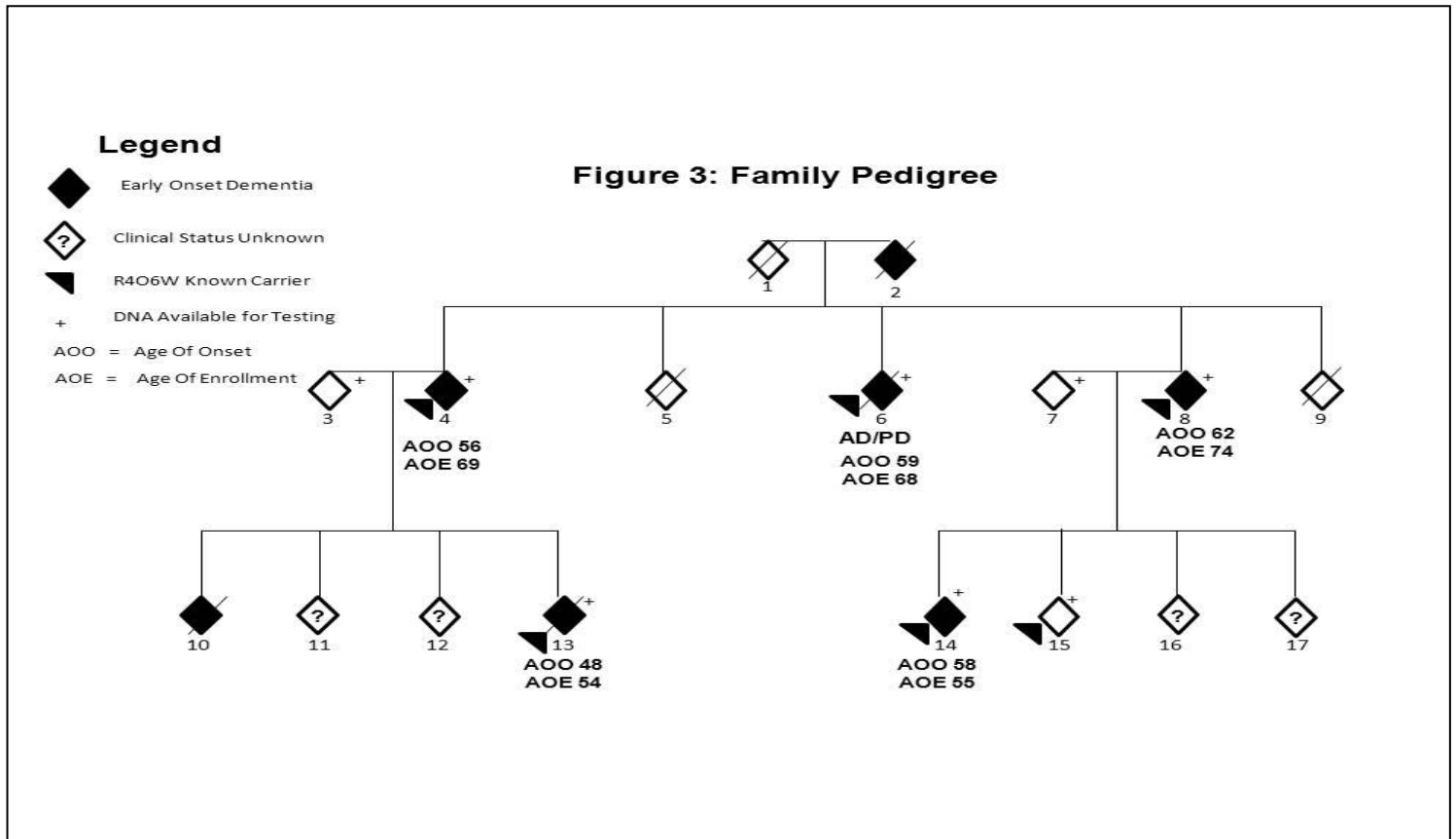

Figure 4: Progression of cognitive change in affected individuals

