

## INS/GPS Integration Architectures

**George T. Schmidt**

Massachusetts Institute of Technology  
10 Goffe Road  
Lexington, MA 02421  
USA

**Richard E. Phillips**

Charles Stark Draper Laboratory  
555 Technology Square  
Cambridge, MA 02139  
USA

### ABSTRACT

*An inertial navigation system (INS) exhibits relatively low noise from second to second, but tends to drift over time. Typical aircraft inertial navigation errors grow at rates between 1 and 10 nmi/h (1.8 to 18 km/h) of operation. In contrast, Global Positioning System (GPS) errors are relatively noisy from second to second, but exhibit no long-term drift. Using both of these systems is superior to using either alone. Integrating the information from each sensor results in a navigation system that operates like a drift-free INS. There are further benefits to be gained depending on the level at which the information is combined. This presentation will focus on integration architectures, including “loosely coupled,” “tightly coupled,” and “deeply integrated” configurations. (Deep integration is trademarked by Draper Laboratory.) The advantages and disadvantages of each level of integration will be listed. Examples of current and future systems will be cited.*

### 1.0 INTRODUCTION

INS/GPS integration is not a new concept [Refs. 1, 2, 3, 4]. Measurements of noninertial quantities have long been incorporated into inertial navigation systems to limit error growth. Examples shown in Figure 1.1 are barometric “altitude” measurements, Doppler ground speed measurements, Doppler measurements to communications satellites, and range measurements to Omega stations.

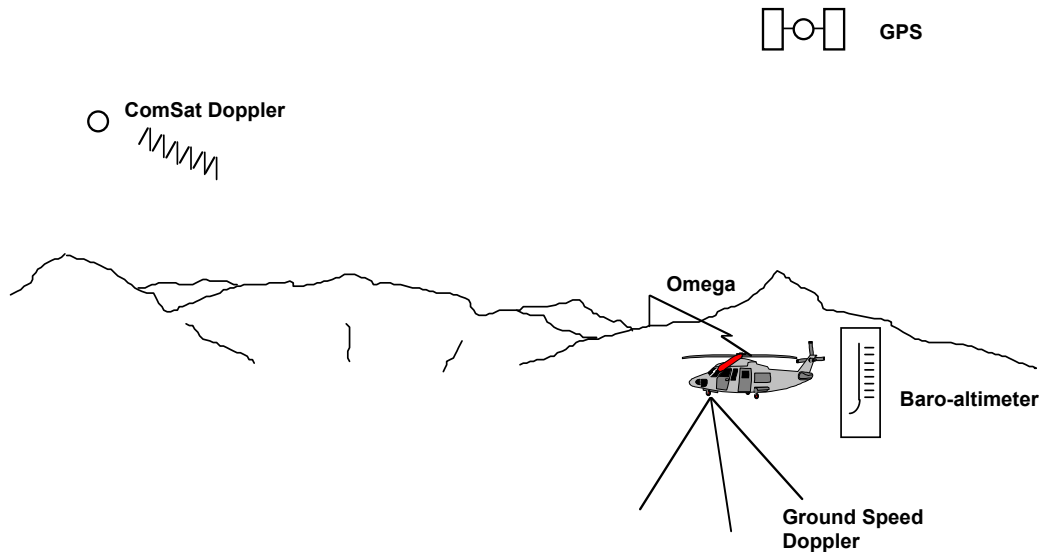

Figure 1.1: Inertial navigation systems can be aided from a variety of sources.

# Report Documentation Page

Form Approved  
OMB No. 0704-0188

Public reporting burden for the collection of information is estimated to average 1 hour per response, including the time for reviewing instructions, searching existing data sources, gathering and maintaining the data needed, and completing and reviewing the collection of information. Send comments regarding this burden estimate or any other aspect of this collection of information, including suggestions for reducing this burden, to Washington Headquarters Services, Directorate for Information Operations and Reports, 1215 Jefferson Davis Highway, Suite 1204, Arlington VA 22202-4302. Respondents should be aware that notwithstanding any other provision of law, no person shall be subject to a penalty for failing to comply with a collection of information if it does not display a currently valid OMB control number.

1. REPORT DATE <b>MAR 2010</b>		2. REPORT TYPE <b>N/A</b>		3. DATES COVERED <b>-</b>	
4. TITLE AND SUBTITLE <b>INS/GPS Integration Architectures</b>				5a. CONTRACT NUMBER	
				5b. GRANT NUMBER	
				5c. PROGRAM ELEMENT NUMBER	
6. AUTHOR(S)				5d. PROJECT NUMBER	
				5e. TASK NUMBER	
				5f. WORK UNIT NUMBER	
7. PERFORMING ORGANIZATION NAME(S) AND ADDRESS(ES) <b>Massachusetts Institute of Technology 10 Goffe Road Lexington, MA 02421 USA</b>				8. PERFORMING ORGANIZATION REPORT NUMBER	
9. SPONSORING/MONITORING AGENCY NAME(S) AND ADDRESS(ES)				10. SPONSOR/MONITOR'S ACRONYM(S)	
				11. SPONSOR/MONITOR'S REPORT NUMBER(S)	
12. DISTRIBUTION/AVAILABILITY STATEMENT <b>Approved for public release, distribution unlimited</b>					
13. SUPPLEMENTARY NOTES <b>See also ADA569232. Low-Cost Navigation Sensors and Integration Technology (Capteurs de navigation a faible cout et technologie d'integration) RTO-EN-SET-116(2010)</b>					
14. ABSTRACT <b>An inertial navigation system (INS) exhibits relatively low noise from second to second, but tends to drift over time. Typical aircraft inertial navigation errors grow at rates between 1 and 10 nmi/h (1.8 to 18 km/h) of operation. In contrast, Global Positioning System (GPS) errors are relatively noisy from second to second, but exhibit no long-term drift. Using both of these systems is superior to using either alone. Integrating the information from each sensor results in a navigation system that operates like a drift-free INS. There are further benefits to be gained depending on the level at which the information is combined. This presentation will focus on integration architectures, including loosely coupled, tightly coupled, and deeply integrated configurations. (Deep integration is trademarked by Draper Laboratory.) The advantages and disadvantages of each level of integration will be listed. Examples of current and future systems will be cited.</b>					
15. SUBJECT TERMS					
16. SECURITY CLASSIFICATION OF:			17. LIMITATION OF ABSTRACT <b>SAR</b>	18. NUMBER OF PAGES <b>18</b>	19a. NAME OF RESPONSIBLE PERSON
a. REPORT <b>unclassified</b>	b. ABSTRACT <b>unclassified</b>	c. THIS PAGE <b>unclassified</b>			

Although GPS provides a deterministic solution for both position and velocity, it has its own shortcomings. Among them are: low data rate (typically 1 Hz), susceptibility to jamming (even unintentional interference), and lack of precision attitude information.

GPS and inertial measurements are complementary for two reasons. Their error characteristics are different and they are measures of different quantities. GPS provides measures of position and velocity. An accelerometer measures specific force. The gyroscopes provide a measure of attitude rate, and after initial alignment, they allow the accelerometer measurements to be resolved into a known coordinate frame.

GPS position measurement accuracy is limited due to a combination of low signal strength, the length of the pseudo-random code, which is about 300 m, and errors in the code tracking loop. Multipath, the phenomenon whereby several delayed copies of the signal arrive at the antenna after being reflected from nearby surfaces, is a source of correlated noise, especially for a moving vehicle. GPS position measurements also have constant or slowly changing biases due to satellite ephemeris and clock errors. These biases are bounded and are not integrated since they are already at the position level.

GPS velocity (position difference) measurements are also noisy, again due to variations in signal strength, the effects of changing multipath, and user clock instability.

In contrast, the accelerometers in an inertial navigation system measure specific force. They have relatively low-noise characteristics when compared with GPS measurements. The signals must be compensated for gravity and integrated twice before providing position estimates. This fundamental difference in radio navigation measurements and inertial measurements is a clue to the difference in the behavior of INS and GPS navigators.

Figure 1.2 shows accelerometer noise (and its first two integrals). The noise level was specified at  $56 \mu\text{g}/\sqrt{\text{Hz}}$ , typical of a 10-nmi/h inertial system. The accelerometer noise itself is shown in the top graph.

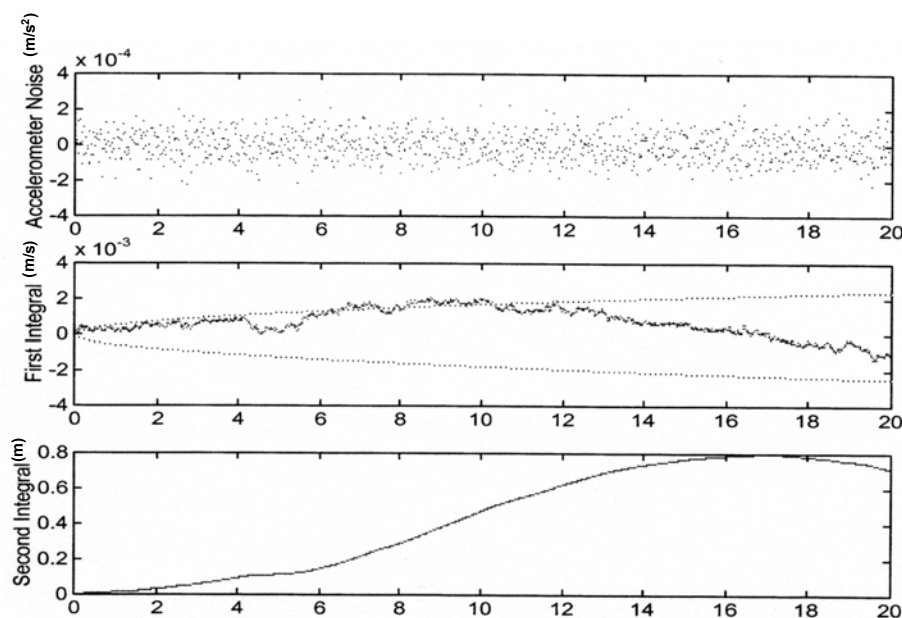

**Figure 1.2: Accelerometer noise and its first two integrals.**

In these graphs, the accelerometer is read every 20 ms for 20 s. The integral of acceleration, the middle graph, shows the familiar “random walk” behavior of the integral of random noise. The dotted lines are the  $1\sigma$  expected errors in the random walk. The second integral, the bottom graph, corresponds to position. (Units are metric: m, m/s and  $m/s^2$ )

GPS receivers typically produce solutions at 1 Hz or 10 Hz. The data bit rate of 50 Hz sets a “natural” minimum of 20 ms between position and velocity determinations. The middle graph in Figure 1.3 shows random noise in a set of measurements. The standard deviation of the velocity measurement is 0.01 m/s, typical of a good GPS receiver and strong signals in a benign environment.

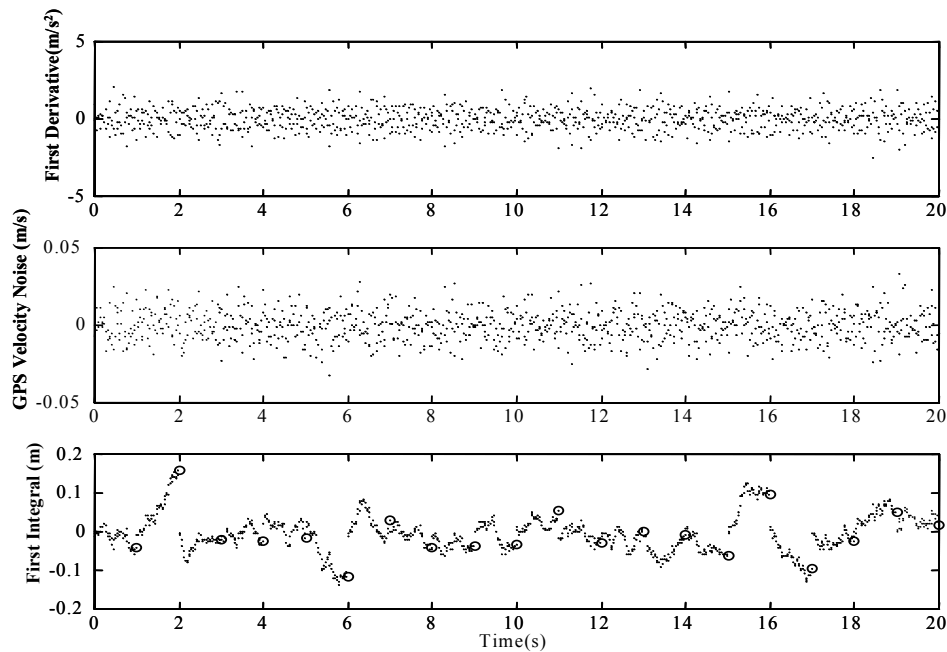

Figure 1.3: GPS velocity measurement noise and its first derivative and first integral.

Back differencing these measurements to match the 50-Hz accelerometer output results in the noisy acceleration measurements as shown in the top graph of the figure. (Again, units are metric: m, m/s and  $m/s^2$ ) The bottom graph of Figure 1.3 shows the first integral of the velocity over 1-s intervals as it might be used for carrier track smoothing of the GPS position measurement. The circles show the value of the integral after each 1-s interval. Thus, they indicate the error in the position difference from one GPS measurement (at 1 Hz) to the next. It is considerably smaller than the measurement error in the position measurement itself, thus the impetus for carrier track smoothing. The position measurement keeps the integral of the carrier track from diverging in the same “random walk” fashion as the integral of accelerometer noise.<sup>1</sup> Users will, quite naturally, want the features of both systems -- the high bandwidth and autonomy of inertial systems, and the long-term accuracy of GPS.

<sup>1</sup> It is not necessary to break the velocity measurement into 20-ms intervals. As suggested by Cox et al. [Ref. 1] it is possible to track the carrier phase continuously from satellite rise to satellite set. Another method for extracting a less noisy velocity would be to recognize that the error at the beginning of one interval is the negative of the error at the end of the preceding interval (if carrier tracking is continuous across the data bit).

Table 1.1 summarizes the features and shortcomings of inertial and GPS navigation systems.

**Table 1.1: Inertial and GPS Attributes and Shortcomings**

	<b>Attributes</b>	<b>Shortcomings</b>
GPS	Self-initializing Errors are bounded	Low data rate Lower attitude accuracy Susceptible to interference (intentional and unintentional) Expensive infrastructure
INS	High data rate Both translational and rotational information Self-contained (not susceptible to jamming)	Unbounded errors Requires knowledge of gravity field Requires initial conditions

The goal of INS/GPS integration, besides providing the redundancy of two systems, is to take advantage of the synergy outlined as follows:

- 1) The conventional approach to aiding the receiver’s carrier and code tracking loops with inertial sensor information allows the effective bandwidth of these loops to be reduced, even in the presence of severe vehicle maneuvers, thereby improving the ability of the receiver to track signals in a noisy environment such as caused by a jammer. The more accurate the inertial information, the narrower the bandwidth of the loops that can be designed. In a jamming environment, this allows the vehicle to more closely approach a jammer-protected target before losing GPS tracking.<sup>2</sup> A minimum of a factor of 3 to 4 improvement in approach distance is typical. A “deeply-integrated” approach to aiding will be shown to be even more robust. Outside a jamming environment, INS data provide high bandwidth accurate navigation and control information and allow a long series of GPS measurements to play a role in the recursive navigation solution. They also provide an accurate navigation solution in situations where “GPS only” navigation would be subject to “natural” short-term outages caused by signal blockage and antenna shading.

The inertial system provides the only navigation information when the GPS signal is not available. Then inertial position and velocity information can reduce the search time required to reacquire the GPS signals after an outage and to enable direct P(Y) code reacquisition in a jamming environment.

- 2) Low-noise inertial sensors can have their bias errors calibrated during the mission by using GPS measurements in an integrated navigation filter that combines inertial system and GPS measurements to further improve the benefits listed under (1) and (2). The accuracy achieved by the combined INS/GPS system should exceed the specified accuracy of GPS alone. The synergistic benefits of combining inertial data with GPS data as described in the previous paragraph are notionally shown in Figure 1.4.

<sup>2</sup> Representative jammers are given in Reference 4.

- 3) Having inertial instruments at the core of the navigation system allows any number of satellites to play a role in the solution.

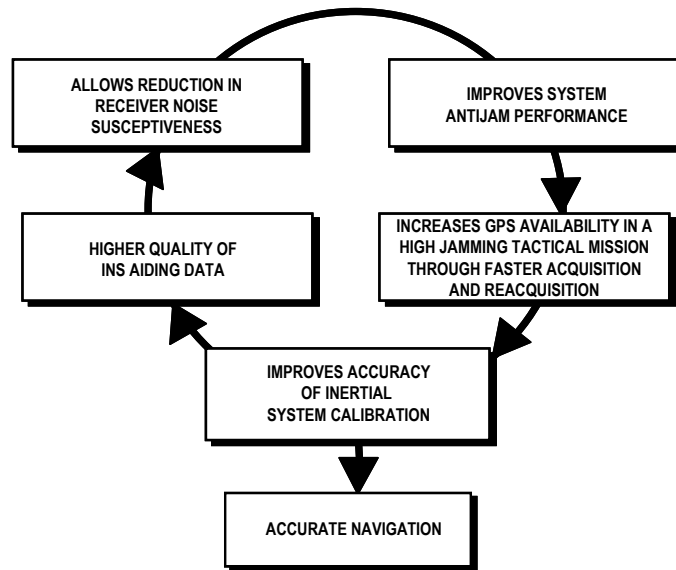

Figure 1.4: The synergy of INS/GPS integration.

The accuracy of the solution, the resistance to jamming, and the ability to calibrate the biases in low-noise inertial system components depend on the avionics system architecture. There have been many different system architectures that have been commonly implemented to combine the GPS receiver outputs and the INS information, thus obtaining inertial sensor calibration, to estimate the vehicle state. Different INS/GPS architectures and benefits will be discussed in the following section.

## 2.0 ALTERNATE INS/GPS ARCHITECTURES

Four architectures will be discussed in this paper: separate systems, loosely coupled, tightly coupled,<sup>3</sup> and deeply integrated systems. Several variations of loosely coupled and tightly coupled systems will be shown.

### 2.1 Separate Systems

The simplest way to get the features of both systems is to simply have both navigation systems integrated only in the mind of the user. Only slightly more complex would be to simply add a correction from the GPS to the inertial navigation solution. Figure 2.1 illustrates such a system.

<sup>3</sup> “Coupled” here refers to combining data from the GPS and INS systems into a single navigation solution. When retrofitting older aircraft with new navigation systems, there is often a problem with space and with power and data connections. For these reasons, it can be desirable to include GPS in the same box with the inertial navigator. This repackaging will be referred to as “embedding.”

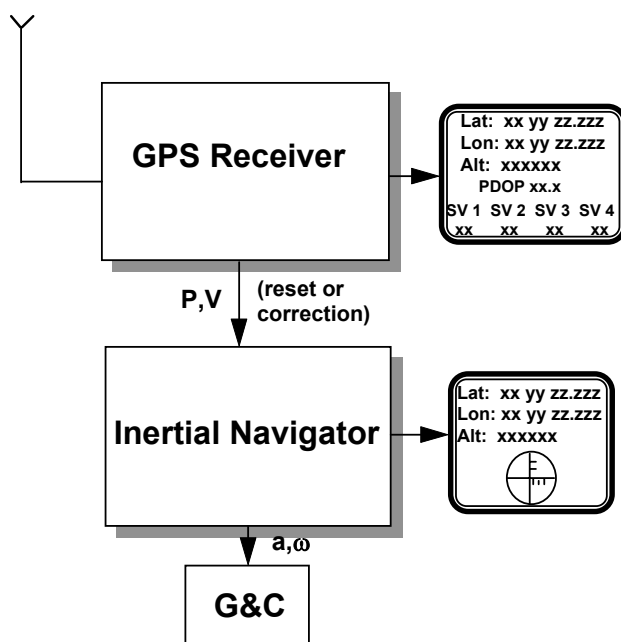

Figure 2.1: Separate GPS and INS systems with a possible INS reset.

This mode of operation or coupling has the advantage of leaving the two systems independent and redundant. But as the Inertial Measurement Unit (IMU) drifts, the inertial solution becomes practically useless.

By using a GPS “reset” or correction, the inertial system errors are kept bounded, but after the first reset, the INS solution is no longer independent of the GPS system. Of course, the corrections could be monitored for reasonableness to prevent the contamination of the inertial solution with grossly incorrect GPS measurements should they occur. Even if not independent, the systems do remain redundant in the sense that they both still have dedicated displays, power supplies, etc., so that the failure of one does not affect the other or leave the vehicle with no navigator.

Inertial system resets provided the first mechanization for the U.S. Space Shuttle GPS integration. The Space Shuttle has a ground uplink capability in which the position and velocity are simply set to the uplinked quantities. For minimum change to the software, the GPS system simply provides a pseudo ground uplink. To make a minimal impact on existing software and hardware is a common rationale for the more loosely coupled systems.

In summary, this architecture offers redundancy, bounded position and velocity estimates, attitude and attitude rate information, high data rates for both translational and rotational information suitable for guidance and control functions, and (for existing systems) minimum impact on hardware and software.

## 2.2 Loosely Coupled

Most often, discussions of INS/GPS integration focus on systems that are more tightly coupled than the system described in the previous section. This will be true of the remaining architectures. Redundancy and solution independence can be maintained, but we will see more benefits from coupling than the simple sum of inertial and GPS navigation features. New software will be required, an integration filter for example.

### 2.2.1 Loosely Coupled – Conservative Approach

Figure 2.2 shows one version of a loosely coupled system. In this system, the functional division could correspond to the physical division with the GPS in a box, the INS in a box, and the computer that combines the navigation solutions in yet another box. Only low rates are required for data links between the boxes. Of course, the three functions could be packaged together if desired.

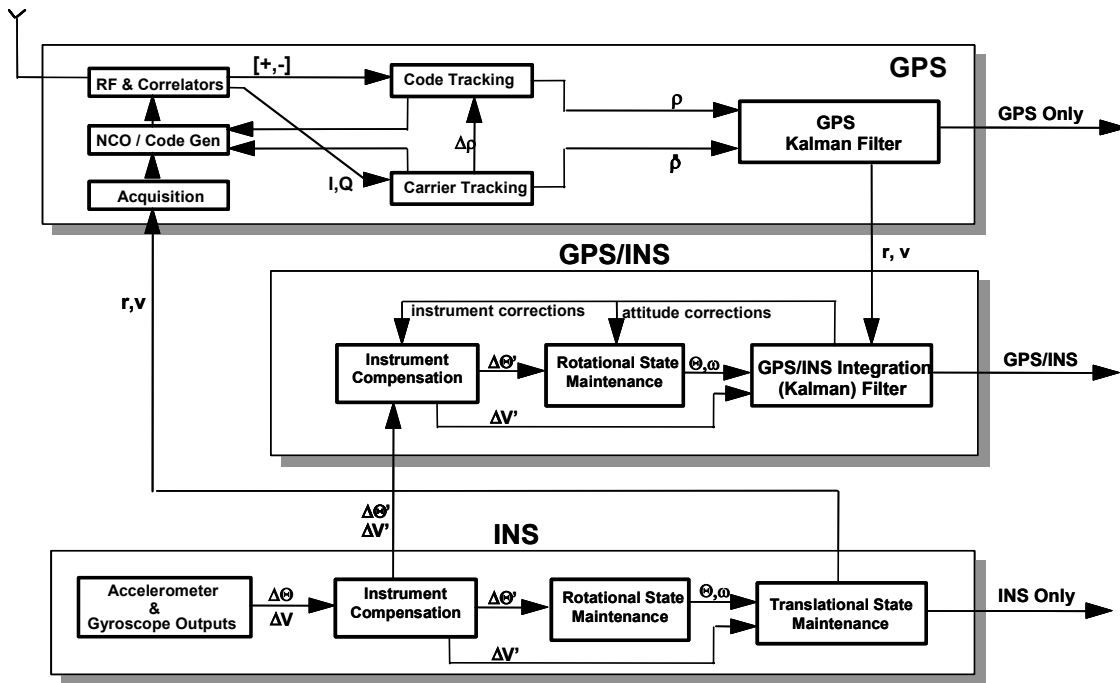

Figure 2.2: A loosely coupled INS/GPS navigation system.

Simplified diagrams for each of the functions are shown. The following paragraphs consist of a high-level description of the operation of a receiver and inertial navigator. It is assumed that the reader has some familiarity with these sensors; thus, the discussion is intended to serve more as a reminder of pertinent features rather than a tutorial.

The receiver diagram shows signals coming into the radio frequency “front end” of the receiver. They are down converted to baseband and fed into the correlators. Meanwhile, a duplicate of the signal is generated internally in the receiver. In fact, three (or more) copies are generated. One of these copies is supposedly time synchronized so that it arrives at the “prompt” correlator at exactly the same time as the signal from the antenna. The other copies are intentionally either a little early or a little late compared with what is expected from the satellite. These copies are sent to the early and late correlators. The magnitude of the early and late correlations, indicated by [+,-] in the figure, is given to the code tracking function. The difference in these magnitudes is an indication of the timing error (and thus range error). This error signal is fed back into the code generator, which makes a correction to the code phase timing. This process is repeated as long as the signal is present. At some point, the phase error will be driven down to an acceptable level, and the code will be declared “in lock.” While “in lock,” the time difference between the broadcast of the signal and the receipt of the signal are a measure of the pseudo-range.



Similarly, the in-phase and quadrature signals are fed into the carrier tracking function. The arctangent of these two signals is a measure of the carrier tracking error. This signal is fed back to the numerically-controlled oscillator (NCO), and its frequency is adjusted accordingly. It might be noted that the carrier tracking loop is typically of third order, allowing it to “perfectly track” signals with constant range acceleration. Note that the carrier loop (when it is “in lock”) “aids” the code loop as indicated by the arrow labeled  $\Delta\rho$ . In this mode, the code tracking loop can be of first order.

For this architecture, the receiver only uses INS data for the purpose of aiding in acquisition. Knowing the position and velocity of the vehicle enables the code generator and oscillator to make good initial guesses of the frequency and code phase of the incoming signal. The search time during acquisition can be reduced significantly depending on the accuracy of these estimates.

The output of the two tracking loops is an estimate of the range and range rate between the vehicle and the satellite. Range and range rate estimates from four satellites are sufficient to resolve the vehicle position, velocity, receiver clock bias, and receiver clock drift rate. For some receivers, these deterministic quantities are the ultimate receiver output. However, receivers that are expected to operate in a dynamic environment use a polynomial Kalman filter to estimate position, velocity, and acceleration, and clock bias and clock drift rate.

A (strapdown) INS diagram is shown at the bottom of the figure. Raw measurements from the accelerometers and gyroscopes are compensated using *a priori* values, or values derived from another mode of operation (e.g., a calibration and alignment mode). The gyroscope output is used to maintain the rotational state of the vehicle. Angular rates are integrated into either a quaternion or matrix, which relates the vehicle attitude to some reference coordinate system (e.g., local level). Corrected  $\Delta V$ 's are rotated into this coordinate system and integrated to maintain the translational state: position and velocity.

The INS/GPS integration function is shown in the middle diagram of the figure. It receives corrected inertial measurements,  $\Delta\Theta'$  and  $\Delta V'$ , from the INS and position and velocity measurements from the GPS receiver. The 1-Hz GPS measurements, coming from a Kalman filter, are highly correlated. The second Kalman filter in this “cascaded” architecture handles this problem by only incorporating these measurements every 10 s. The 10-s interval allows each position/velocity measurement to be more or less independent of the previous measurements. A performance comparison between this loosely coupled architecture and a tightly coupled architecture is given in Reference 5. Note that the integration Kalman filter includes calibration and alignment estimates that provide in-flight improvement of the INS calibration and alignment. This conservative approach to coupling yielded surprisingly good results in estimating these gyro and accelerometer parameters.

Table 2.1 summarizes the functions of the three components of the system. Table 2.2 lists the attributes of the system.

**Table 2.1: Functions of the three components of the loosely coupled system**

Component	Function
GPS	The Kalman filter estimates: Position, velocity, acceleration Clock bias, clock drift
INS	The INS provides: Position, velocity, acceleration Attitude, attitude rate
Integration Filter	The integration filter estimates: Position, velocity Attitude corrections, instrument corrections

**Table 2.2: Loosely coupled system attributes**

System Attributes
All the attributes of the previous “uncoupled” architecture, including redundant and independent INS and GPS solutions
More rapid acquisition of code and carrier phase
Improved navigation performance
In-flight (and better) calibration and alignment, which results in improved navigation during satellite loss/jamming

We distinguish between jamming resistance and mitigation against jamming. By the latter term, we simply mean that the inertial bias and scale-factor parameters will be better calibrated so that if the GPS signal is lost, the INS/GPS solution (receiving only inertial data) will be accurate for longer than otherwise.

### 2.2.2 Loosely Coupled-Aggressive Approach

Figure 2.3 shows possible variations in what may still be considered a loosely coupled architecture. Inertial aiding of tracking loops has not yet been introduced, and the integration filter still uses position and velocity data rather than pseudo-range and range rate. Additional data transfer beyond that of the previous architecture is indicated by heavy lines. Either one or the other or both data transfers are viable options.

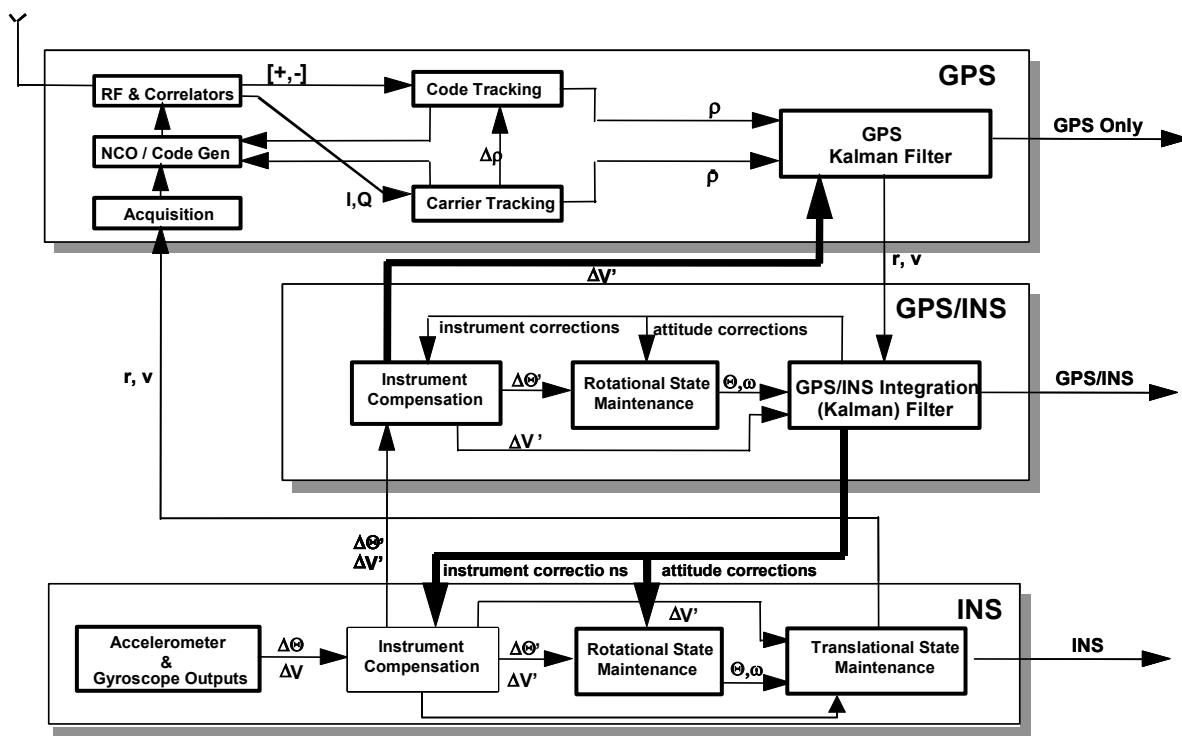

Figure 2.3: Loosely coupled variations use the results of the integration filter in both the GPS and INS solutions.

The first of these data transfers is of the corrected velocity increment  $\Delta V'$  from the INS/GPS module to be used in the GPS module to propagate the solution between measurements. This provides a vast improvement in dynamic situations. Otherwise, the propagation must be done using the acceleration estimate from the GPS Kalman filter itself. This acceleration, although a component of the filter state, is derived by back differencing the velocity. Figure 1.3 showed the level of acceleration noise inherent in this operation. It is true that the filter offers some “smoothing.” However, it cannot offer much due to the process noise, which must be added in the dynamic aircraft environment. There is a requirement by the U.S. GPS Joint Program Office that the receiver be able to maintain track at a jerk level of 10 g/s for 0.6 s. Although this requirement is on the tracking loops, it most certainly has implications for the process noise that must be added to the acceleration covariance term in the GPS Kalman filter. There is no substitute for using the measured acceleration.

The other optional data transfer is that of the in-flight calibration and alignment corrections from the INS/GPS estimator to the INS. This helps keep the INS in closer agreement with the INS/GPS solution. Of course, the independence of the two solutions is lost.

In summary, we have improved the navigation accuracy of the combined GPS and the INS at the cost of independence in their solutions. We have maintained redundant systems.

### 2.2.3 Loosely Coupled – Rockwell's MAGR Approach

This approach might actually be characterized somewhere between loosely and tightly coupled. Figure 2.4 shows the GPS and INS functions and interfaces between them. The MAGR (Military Airborne GPS

Receiver) has an INS mode and a PVA (Position, Velocity, and Acceleration) mode. The latter is a stand-alone mode independent of inertial measurements.

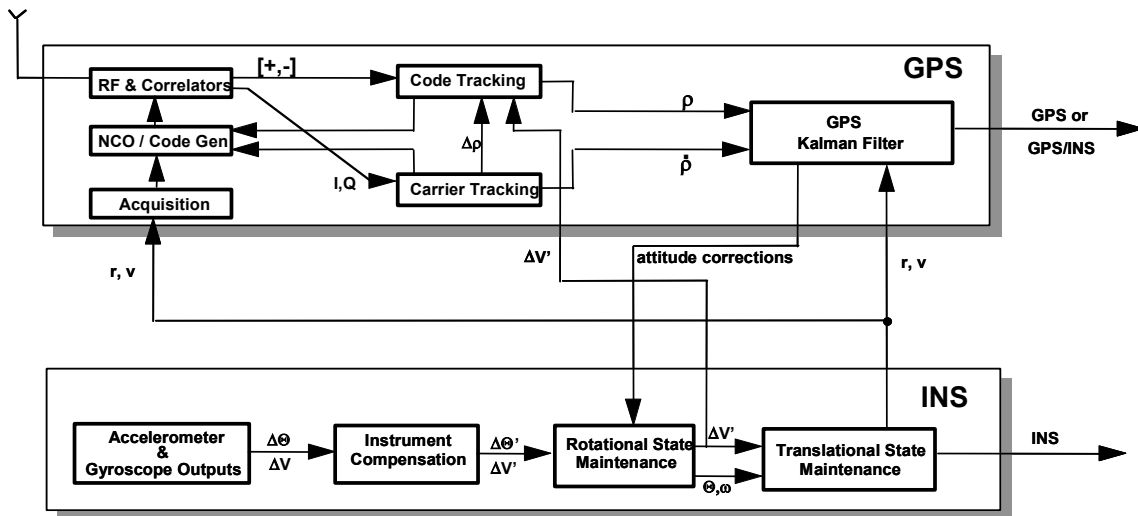

Figure 2.4: The coupling approach taken by the Rockwell MAGR.

In the INS mode, inertial measurements are used to aid the code tracking loop when the carrier loop is out of lock and unable to provide aiding. The GPS uses the inertial measurements to extrapolate the position and velocity between GPS measurements rather than estimating acceleration in a polynomial filter. The GPS estimates attitude corrections for the IMU. The MAGR (in the INS mode) thus has some of the features of a tightly coupled system. Table 2.3 lists the filter state elements for the PVA and INS mode of operation.

Table 2.3: Filter states for the MAGR

PVA Mode	INS Mode
Position	Position
Velocity	Velocity
Acceleration	Attitude corrections
Clock bias	Clock bias
Clock drift	Clock drift
Barometer bias	Barometer bias

### 2.3 Tightly Coupled

Finally, the two changes that define a tightly coupled system are introduced. The GPS range and delta range measurements are incorporated directly into the navigation estimate, and the position and velocity from the inertial system are used by the GPS receiver to reduce the tracking loop bandwidths even in the presence of high dynamics.<sup>4</sup> First, a straightforward system that provides a single combined INS/GPS solution will be

<sup>4</sup> The definitions of tightly coupled are not universally agreed upon. The first round of “EGI” receivers were considered to be tightly coupled by some but they did not have inertial aiding of the carrier tracking loops.

presented. Then a system that also maintains independent and redundant GPS and INS solutions will be presented.

### 2.3.1 Tightly Coupled – Combined INS/GPS Only

Figure 2.5 shows the architecture for a tightly coupled INS/GPS navigation system that offers a single navigation solution. The INS and GPS modules have been truncated. The inertial “system” now simply provides raw measurements. The GPS receiver does not have its own Kalman filter, but it does still have independent tracking loops that provide the values for pseudo-range and range rate. Although it has not been shown in any of the figures, it is of course understood that the pseudo-range and range rate to at least four satellites are required for a position and velocity determination. The GPS functions shown in the upper diagram of Figure 2.5 are duplicated for each satellite by having multiple “channels” in a receiver - only one of which is shown in the diagram.

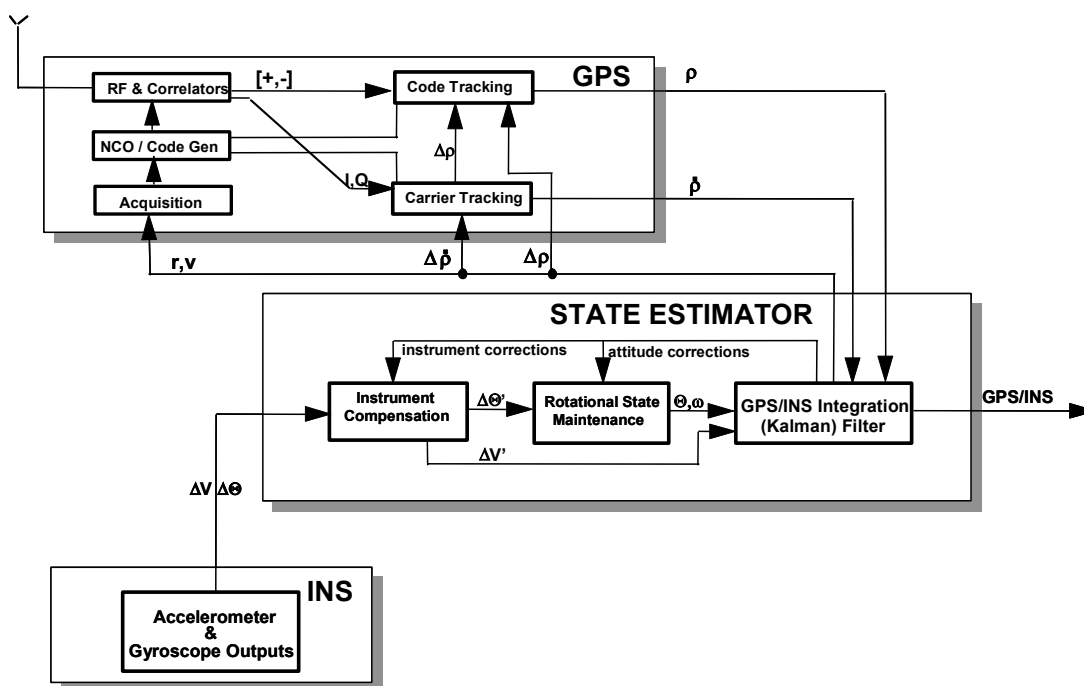

Figure 2.5: A tightly coupled INS/GPS navigation system offering only one combined solution.

The tracking loops in the receiver are aided by data from the INS/GPS state estimator. These data are required at a high rate, thus the propagation from one measurement epoch to another is broken into many subintervals for the purpose of tracking loop aiding. The goal is to make these tracking loops “think” the receiver is sitting still. The quantities being estimated by the Kalman filter are position and velocity, whereas the data required by the tracking loops are code phase (range) and Doppler frequency shift (range rate). The estimated position and velocity and the satellite ephemerides are used to calculate the code phase and frequency shift. The diagrams in this paper will show the transfer of  $r$ ,  $v$ , and delta range and range rate, implying that these calculations are done in the receiver. They could as well be done in the “State Estimator” box. The bandwidth of the tracking loops must only accommodate the errors in the measured acceleration rather than the whole acceleration. These errors are many orders of magnitude less than the acceleration itself, depending on the quality of the inertial system and its calibration.

The tightly coupled navigation systems are more accurate. This can be seen in Reference 5, where tightly and loosely coupled systems are compared. We still have the gains or attributes of the loosely coupled systems except for the loss of redundancy. The bandwidth of the tracking loops can be reduced, thus increasing jamming resistance. The integration filter can make optimal use of any and all satellites that are being tracked, even if there are less than four of them. It should be said that GPS-only solutions can be maintained with either three or two satellites if one or two or both of the following assumptions are made: 1) the clock bias is constant and 2) the altitude is constant or is known by some other means (e.g., a baroaltimeter).

Only the redundancy offered by three complete systems is lost for this architecture. A summary of the benefits accrued by coupling will be given at the end of Section 2.3.2.

### 2.3.2 Tightly Coupled – Redundant Solutions

Figure 2.6 illustrates a tightly coupled architecture that also offers redundant navigation solutions from both the GPS and INS. This figure most closely resembles the Figure 2.3 for the loosely coupled architecture. The changes with reference to that earlier figure are inertial aiding of the tracking loops from the INS/GPS solution and the use of pseudo-range and range rate measurements rather than position and velocity in the integration filter.

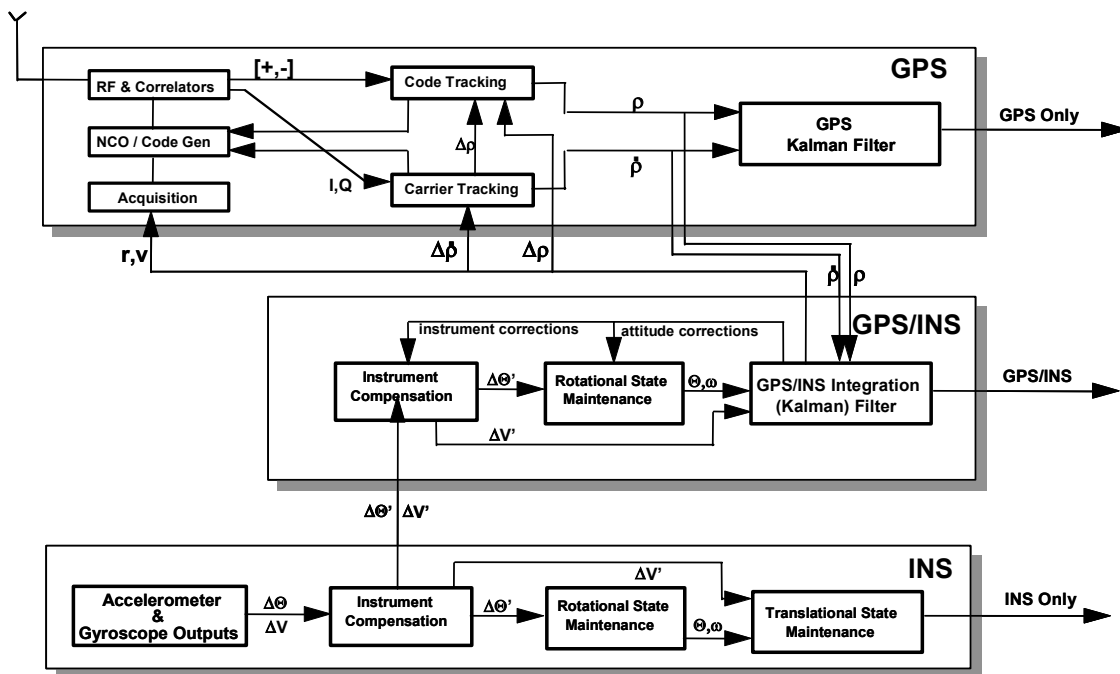

Figure 2.6: Tightly coupled architecture with redundant GPS and INS-only solutions.

This more elaborate system requires more software. This is the price of the redundancy unless the software is already present in existing INSs and GPS. This can indeed be the case and was the case in the U.S. GPS Joint Program Office's Embedded GPS Inertial (EGI) program. The concept of the EGI program was to obtain a navigation system with GPS and inertial attributes at minimum cost. Specifications for such a (nondevelopmental) system were published. Several vendors have produced such embedded systems, among

them are LN-100G [Ref. 6] and the H-764G [Ref. 7] combinations of GPS with ring laser gyroscopes. The U.S. Advanced Research Projects Administration also sponsored a tightly coupled and embedded combination, the GPS Guidance Package, using fiber-optic gyroscopes.

Embedding the receivers allows the data transfer rates required for tight coupling. EGI specifications state that separate and independent inertial-only and GPS-only solutions are to be maintained. Although they do not specify the two characteristics we have used to define tight coupling, they do state that INS aiding of the tracking loops is allowed [Ref. 8]. This potentially makes the GPS solution dependent on the INS. Mathematical independence is maintained if the tracking loops have adequate signal strength to work with and can maintain lock such that the error in range rate (for example) is independent of the aiding value. If the error in the tracking loops is independent of the aiding, the GPS and INS/GPS solutions will be independent. Logic in the receivers attempts to recognize when lock is lost and not incorporate the resulting “bad” measurements into the GPS solution. This precaution also (arguably) keeps the GPS solution mathematically independent of the other solutions.

The tightly coupled receiver offers elevated jamming resistance. It offers the ability to continue operation when GPS is intermittent due to wing shadowing, foliage, or other natural or man-made obstructions. Table 2.4 summarizes the benefits that have been gained by coupling GPS with INS. The benefits are cumulative. That is, the benefits for each level also include those for the previous level. (The exception is loss of redundancy and independence for the simpler of the tight coupling architectures.)

**Table 2.4: Cumulative Benefits of Increasingly Tight Coupling**

<b>Coupling Level</b>	<b>Benefit</b>
Uncoupled/reset INS to GPS (Sum of system attributes)	Position, velocity, acceleration, attitude, and attitude rate information Redundant systems - A drift-free GPS - A high-bandwidth INS
Loosely coupled	More rapid GPS acquisition In-flight calibration and alignment Better inertial instrument calibration and alignment - Better attitude estimates - Longer operation after jamming
Tightly coupled	Better navigation performance Better instrument calibration Reliable tracking under high dynamics Reduced tracking loop bandwidth (jamming resistance) Optimum use of however many SVs available

## 2.4 Deeply Integrated

Figure 2.7 shows the architecture of a deeply integrated INS/GPS navigation system. This figure compares most closely with the first tightly coupled architecture shown in Figure 2.4. In the deeply integrated concept, independent tracking loops for the code and carrier have been eliminated.

In the deeply integrated approach, the problem is formulated directly as an estimation problem in which the optimum (minimum-variance) solution is sought for each component of the multidimensional navigation state vector.<sup>5</sup> By formulating the problem in this manner, the navigation algorithms are derived directly from the assumed dynamical models, measurement models, and noise models. The solutions that are obtained are not based on the usual notions of tracking loops and operational modes (e.g., State 3, State 5, etc.). Rather, the solution employs a nonlinear filter that operates efficiently at all jammer/signal (J/S) levels and is a significant departure from traditional extended Kalman filter designs. The navigator includes adaptive algorithms for estimating post-correlation signal and noise power using the full correlator bank. Filter gains continuously adapt to changes in the J/S environment, and the error covariance propagation is driven directly by measurements to enhance robustness under high jamming conditions (see Figure 2.8).

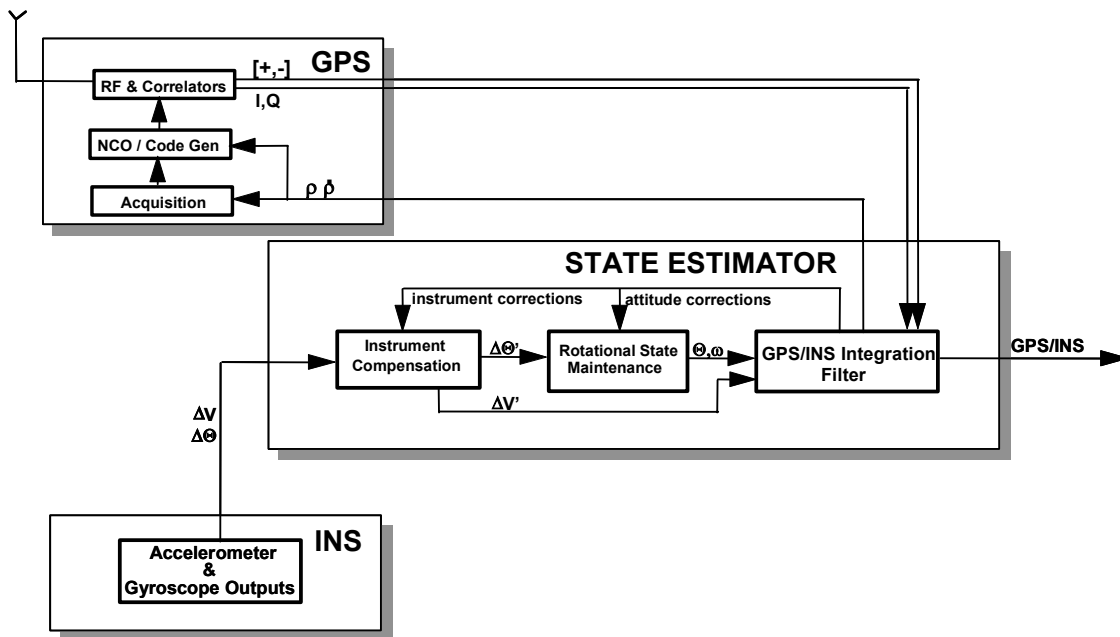

Figure 2.7: Deeply integrated INS/GPS systems feature a single estimator for both detection and navigation.

<sup>5</sup> The material in this section is from References 9 and 10 “Deep integration” is trademarked by Draper Laboratory..



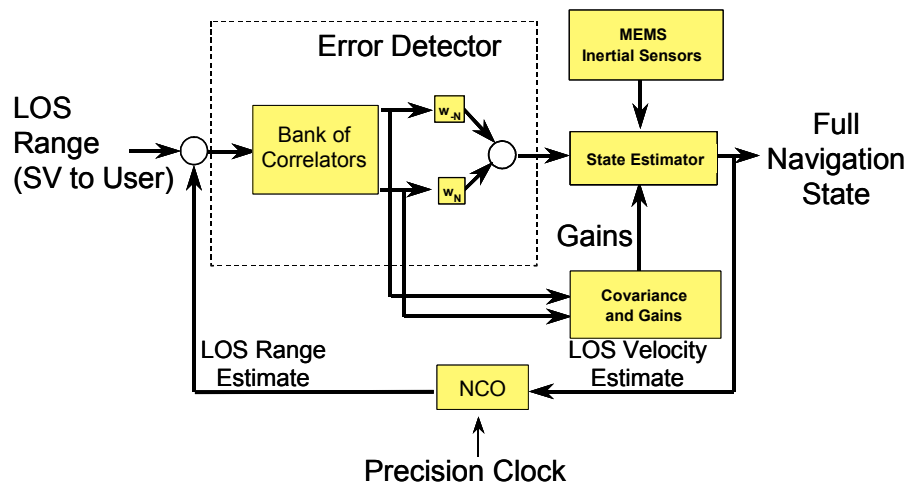

Figure 2.8: INS/GPS deep integration.

In this system, individual satellite phase detectors and tracking loop filters are eliminated. Measurements from all available satellites are processed sequentially and independently, and correlation among the line-of-sight distances to all satellites in view is fully accounted for. This minimizes problems associated with unmodeled satellite signal or ephemeris variations and allows for full Receiver Autonomous Integrity Monitoring (RAIM) capability.

The design offers several significant benefits at high J/S levels. The effects of measurement nonlinearities, which are significant at high J/S levels, are accounted for in an efficient manner. The estimator produces near-optimal state vector estimates as well as estimates of the state error covariance matrix. The estimator operates in real time using recursive algorithms for both state vector and error covariance matrix estimation. The J/S levels are estimated adaptively in real time to facilitate seamless transitions between course tracking and tight tracking without the use of artificial moding.

Extended-range correlation may be included optionally to increase the code tracking loss-of-lock threshold under high jamming and high dynamic scenarios. If excessively high jamming levels are encountered (e.g., beyond 70 to 75 dB J/S at the receiver input for P(Y) code tracking), the GPS measurements may become so noisy that optimal weights given to the GPS measurements become negligible. In this situation, navigation error behavior is essentially governed by current velocity errors and the characteristics of any additional navigation sensors that are employed. Code tracking is maintained as long as the line-of-sight delay error remains within the maximum allowed by the correlator bank. If there is a subsequent reduction in J/S so that the optimal weights become significant, optimum code tracking performance is maintained without the need for reacquisition. Detector shapes for each correlator depend on the correlator lag and rms line-of-sight delay error.

For navigators using GPS only, navigation errors will be reduced significantly by using algorithms that approximate the minimum-variance solutions at high J/S. For navigators employing other sensors, a fully integrated system will allow simpler, smaller, cheaper hardware to be employed. Superior sensor calibration capability will reduce sensor performance requirements, allowing lower-cost sensors to be used.

Figure 2.9 shows the information flow between the principal elements of the navigation system. The data from each satellite in view are processed sequentially; the figure illustrates processing for a single satellite.

The GPS receiver front end performs filtering, carrier wipeoff and sampling to produce I/Q data. These data are processed by each correlator to produce the 50-Hz samples  $I_{50}(j,k)$  and  $Q_{50}(j,k)$  for the  $k^{th}$  correlator at the  $j^{th}$  time point. Square law detection and summation is then used to obtain  $Z_k(n)$ ; currently, summation is over five samples so that  $Z_k(n)$  is 10-Hz data. The processor uses inputs  $Z_k(n)$  to calculate the navigation state estimate  $\hat{x}(n)$ . The state estimate is propagated to measurement update time using an assumed dynamical model. As shown in the figure (dashed lines), two types of sensors may be optionally added to the GPS-based navigator. Inertial sensor data may be incorporated during propagation to reduce the error bandwidth during periods of high dynamics and retard error growth if code lock is lost. If inertial sensors are used, the processor accepts raw sensor data (e.g., body frame specific force and angular rates for a strapdown configuration) and time-correlated sensor error states may be included in the navigation state vector in order to perform in-flight calibration of significant error sources. At measurement update time, the state is updated using the measurements  $\{Z_k(n); k = -m, \dots, m\}$  from  $2m + 1$  correlators, satellite ephemeris data, and (optionally) measurements from other sensors (e.g., radars, altimeters, etc.). The estimated time delay  $\hat{\tau}(n)$ , which is a function of the state estimate and satellite ephemeris, is fed to the code NCO, which controls correlator code phase in order to maintain the mean code tracking error close to zero.

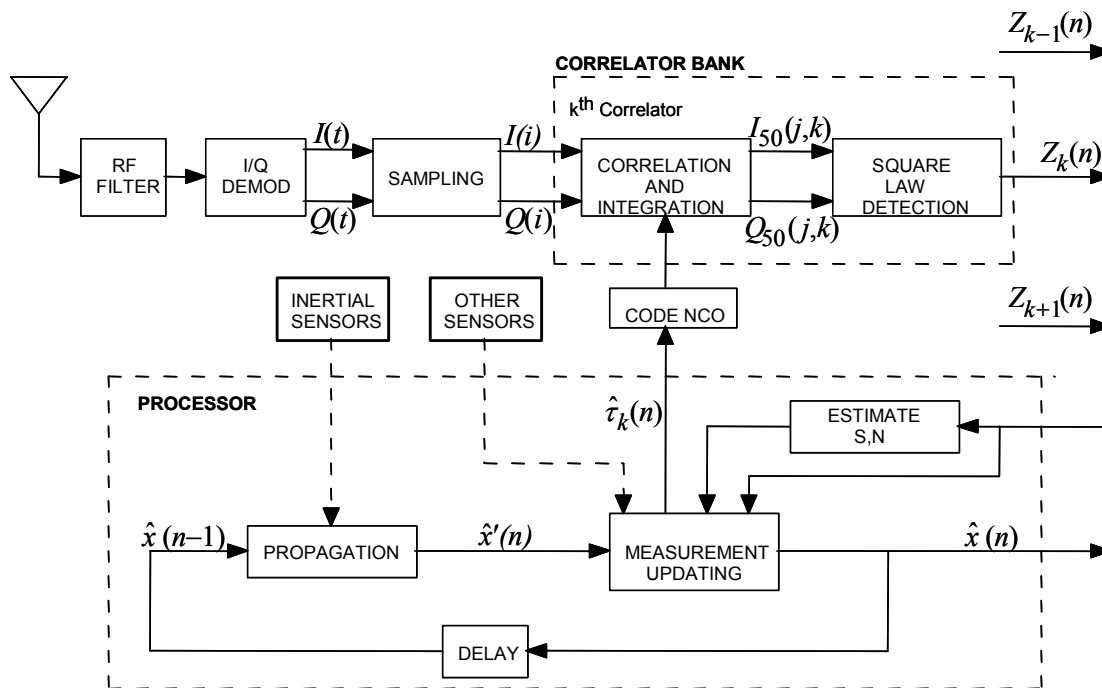

Figure 2.9: Code tracking information flow diagram for GPS-based navigator.

The navigator includes adaptive algorithms for estimating postcorrelation signal power (S) and noise power (N). Noise statistics are assumed to be the same for all correlators. Although the 50-Hz noises are uncorrelated over time, the noise in adjacent correlators is correlated.

### 3.0 SUMMARY

This paper has described INS/GPS integration architectures including loosely coupled, tightly coupled, and deeply integrated configurations. The advantages and disadvantages of each level of integration were listed. Examples of current and futures systems were cited. In a companion paper, Reference 5, performance comparisons between the three major INS/GPS system architectures for various mission scenarios will be presented in order to understand the benefits of each. The loosely coupled and tightly coupled systems will be compared in several scenarios including aircraft flying against jammers and a helicopter flying a scout mission. The tightly coupled and deeply integrated architectures will be compared for several jamming scenarios including that of a precision guided munition.

### REFERENCES

- [1] Cox, D.B., Kriegsman, B.A., Stonestreet, W.M., Kishel, J., and Calicchia, L.V. *Feasibility Study of GPS-Inertial Navigation for Helicopters and Study of Advanced GPS Signal Processing Techniques*, Draper Laboratory Report R-981, Cambridge, MA. March 1978.
- [2] Cox, D.B. "Inertial Integration of GPS," *Global Position System - Papers Published in Navigation*, Vol. 1, Institute of Navigation, Alexandria, VA, 1980.
- [3] Grewal, M. et.al., *Global Positioning Systems, Inertial Navigation and Integration*, J. Wiley & Sons, 2007.
- [4] Schmidt, G., *INS/GPS Technology Trends*, NATO RTO Lecture Series, RTO-EN-SET-116, *Low-Cost Navigation Sensors and Integration Technology*, March 2010.
- [5] Schmidt, G. and Phillips, R., *INS/GPS Integration Architecture Performance Comparisons*, NATO RTO Lecture Series, RTO-EN-SET-116, *Low-Cost Navigation Sensors and Integration Technology*, March 2010.
- [6] Lipman, Jerome S., "Trade-offs in the Implementation of Integrated GPS Inertial Systems," *Proceedings of the Institute of Navigation GPS-92 Technical Meeting*, The Institute of Navigation, Alexandria, VA, 1992.
- [7] Moya, David C., Elchynski, Joseph J., "Evaluation of the World's Smallest Integrated Embedded INS/GPS, the H-764G," *Proceedings of the National Technical Meeting of the Institute of Navigation*, The Institute of Navigation, Alexandria, VA, 1993, pp. 275-286.
- [8] *Systems Requirement Document for an Embedded Global Positioning System (GPS) Receiver in an Inertial Navigation System (INS) EGI*, ASC/SMEV Wright Patterson AFB, Ohio 45433-6503.
- [9] Gustafson, D. et. al., *A Deeply Integrated Adaptive GPS-Based Navigator with Extended Range Code Tracking*, Draper Laboratory Report P-3791, Cambridge, MA, January 2000. Also, IEEE Plans Conference, San Diego, CA, March 2000.
- [10] Gustafson, D. et. al., *A High Antijam GPS-Based Navigator*, Draper Laboratory Report P-3776, Cambridge, MA, January 2000. Also, Institute of Navigation National Technical Meeting, Anaheim, CA, January 2000.