



BAE SYSTEMS	Unclassified	Approved for Public Release; Distribution Unlimited
GENERAL DYNAMICS Robotic Systems	Survivability on the ART Robotics Vehicle	
 TARDEC	John Steen Control Point Corporation For BAE Systems	
	Michael Del Rose U.S. Army TARDEC – Intelligent Systems	
	Unclassified	

Outline	BAE SYSTEMS	GENERAL DYNAMICS Robotic Systems	 TARDEC
Unclassified			
<ul style="list-style-type: none"> ▪ ART Program ▪ Sensor Configuration ▪ Anti-Tamper ▪ Intent Analysis (Visual and IDS system) ▪ Countermeasures (Tactical Behaviors) 			
Unclassified			
2			

Report Documentation Page

Form Approved
OMB No. 0704-0188

Public reporting burden for the collection of information is estimated to average 1 hour per response, including the time for reviewing instructions, searching existing data sources, gathering and maintaining the data needed, and completing and reviewing the collection of information. Send comments regarding this burden estimate or any other aspect of this collection of information, including suggestions for reducing this burden, to Washington Headquarters Services, Directorate for Information Operations and Reports, 1215 Jefferson Davis Highway, Suite 1204, Arlington VA 22202-4302. Respondents should be aware that notwithstanding any other provision of law, no person shall be subject to a penalty for failing to comply with a collection of information if it does not display a currently valid OMB control number.

1. REPORT DATE 24 MAR 2006		2. REPORT TYPE Briefing Charts		3. DATES COVERED 24-03-2006 to 24-03-2006	
4. TITLE AND SUBTITLE SURVIVABILITY ON THE ARMED ROBOTIC TECHNOLOGY ROBOTICS VEHICLE				5a. CONTRACT NUMBER	
				5b. GRANT NUMBER	
				5c. PROGRAM ELEMENT NUMBER	
6. AUTHOR(S) John Steen; Michael Del Rose				5d. PROJECT NUMBER	
				5e. TASK NUMBER	
				5f. WORK UNIT NUMBER	
7. PERFORMING ORGANIZATION NAME(S) AND ADDRESS(ES) U.S. Army TARDEC ,6501 E.11 Mile Rd,Warren,MI,48397-5000				8. PERFORMING ORGANIZATION REPORT NUMBER #15636	
9. SPONSORING/MONITORING AGENCY NAME(S) AND ADDRESS(ES) U.S. Army TARDEC, 6501 E.11 Mile Rd, Warren, MI, 48397-5000				10. SPONSOR/MONITOR'S ACRONYM(S) TARDEC	
				11. SPONSOR/MONITOR'S REPORT NUMBER(S) #15636	
12. DISTRIBUTION/AVAILABILITY STATEMENT Approved for public release; distribution unlimited					
13. SUPPLEMENTARY NOTES presented at Ground Vehicle Survivability Symposium (gvss) 2006					
14. ABSTRACT N/A					
15. SUBJECT TERMS					
16. SECURITY CLASSIFICATION OF:			17. LIMITATION OF ABSTRACT Same as Report (SAR)	18. NUMBER OF PAGES 9	19a. NAME OF RESPONSIBLE PERSON
a. REPORT unclassified	b. ABSTRACT unclassified	c. THIS PAGE unclassified			

Armed Robotic Technology (ART) Platform

BAE SYSTEMS

GENERAL DYNAMICS
Robotic Systems



Unclassified

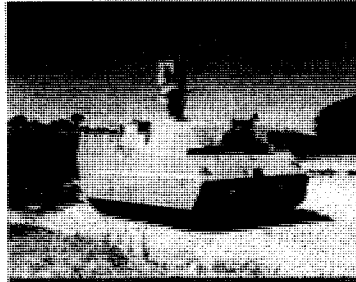

Purpose:

Advance the state of the art in unmanned platform technologies to achieve FCS ORD Objective capabilities of UGV systems.

Product:

- Enhanced Semi-Autonomous Mobility Suite
- Integrated Tactical/Mission Behavior System
- Increased Platform Maneuverability
- Survivability Technology/Devices/Payload

Payoff:

- Reduced soldier burden/interaction
- Improved semi-autonomous operation in adverse weather and urban/complex terrain.
- Tactical behavior incorporated into semi-autonomous maneuver.
- Increased mobility over rough terrain.
- Increased soldier survivability using unmanned systems.
- Reduced risk to FCS ARV and MULE

Schedule

MILESTONE (FY)	05	06	07	08	09
• Develop ARV Technologies		█	█	█	
• Develop UGV Mobility M&S Suite			█	█	
• Analyze UGV Vulnerabilities and develop countermeasures			█	█	
• System Integration and Test				█	█
• Conduct Warfighter Experiments and Evaluations					█

Unclassified

3

ART Sensors

BAE SYSTEMS

GENERAL DYNAMICS
Robotic Systems



Unclassified

- Intrusion Detection System (IDS) Radar
 - FM/CW
 - FOR: 100m X 360deg H X ±30deg V
- RSTA
 - Visible, NIR, IR, LRF
 - FOR: 360deg H X 30deg V
 - ATD/AiTR
- Autonomous Mobility System (AMS)
 - Visible, NIR, IR, LADAR
 - FOR: 100m X 360deg H

Unclassified

4

ART Sensor Configuration

BAE SYSTEMS

GENERAL DYNAMICS
Robotic Systems



Unclassified

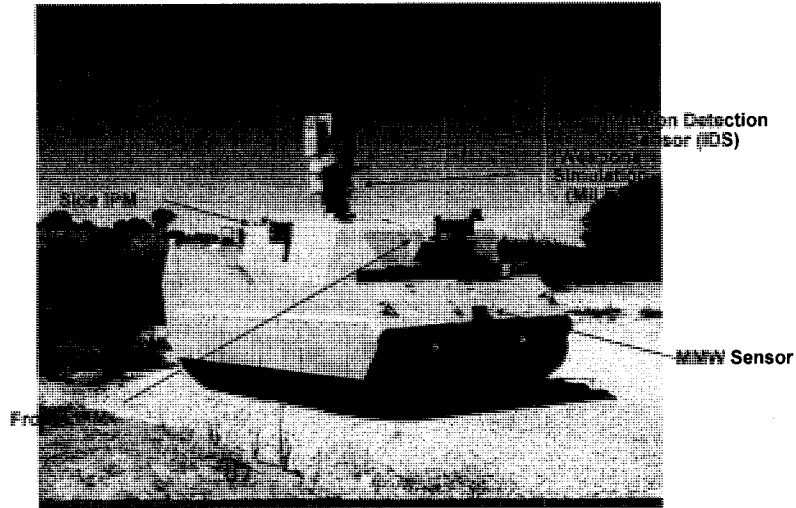

Unclassified

5

ART Sensor Coverage

BAE SYSTEMS

GENERAL DYNAMICS
Robotic Systems



Unclassified

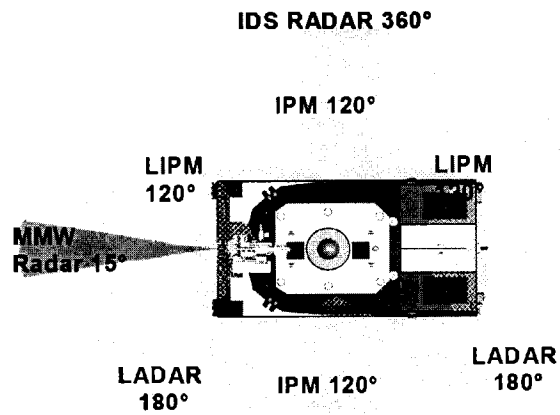

Unclassified

6

Anti-Tamper

BAE SYSTEMS

GENERAL DYNAMICS
Robotic Systems



Unclassified

- **What is “Anti-tamper” protection?**

For ART: Anti-tamper refers to a system that determines the threat of an approaching person and actions to avoid the threat. It does NOT imply the ability of systems to be rendered useless (as traditionally defined).

- **Anti-tamper for the ART platform uses Visual Intent Analysis and IDS Radar.**

Unclassified

7

Intent Analysis - Visual System

BAE SYSTEMS

GENERAL DYNAMICS
Robotic Systems



Unclassified

- **Visual Intent Analysis framework**

- Uses pedestrian detection/tracking to determine and track people as differentiated from other objects.
- Classifies the intent of the people based on movements.
- Hostile intentions trigger countermeasures (tactical behaviors).

Unclassified

8

Visual Intent Analysis - Pedestrian Detection/Tracking

BAE SYSTEMS

GENERAL DYNAMICS
Robotic Systems



Unclassified

- Uses stereo infrared and color cameras to identify people and track them using disparity mappings, color blob analysis, and body positions.
- Tracks people through occlusions.

Unclassified

9

Visual Intent Analysis - Pedestrian Detection/Tracking

BAE SYSTEMS

GENERAL DYNAMICS
Robotic Systems



Unclassified

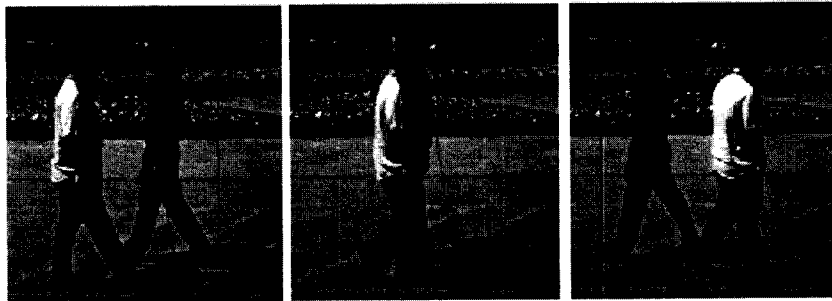

Unclassified

10

Visual Intent Analysis - Determining Intent Visually

BAE SYSTEMS

GENERAL DYNAMICS
Robotic Systems



Unclassified

Video data hierarchy

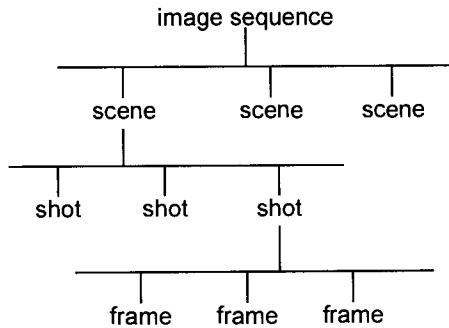

Scenes: Global content and Intent.

Shot: Objects and object relations, motion, and locations of objects

Frames: Low level – color, texture, and shape.

Unclassified

11

Visual Intent Analysis - Identify the Scene

BAE SYSTEMS

GENERAL DYNAMICS
Robotic Systems



Unclassified

- Identifying the scenes (and shots) requires a well defined feature space.
- Usually requires color and motion.
- Basically, we are trying to find major changes in the image sequence.

Unclassified

12

Visual Intent Analysis - Identify the Scene

BAE SYSTEMS

GENERAL DYNAMICS
Robotic Systems



Unclassified

Modeling Scene into Simple Verbs

- From identifying and tracking the objects in the scene, we can determine their actions and their relationship with each other.
- Examples of simple verbs are: pickup, putdown, move, touch, etc.

Unclassified

13

Visual Intent Analysis - Identify Intent of the Scene

BAE SYSTEMS

GENERAL DYNAMICS
Robotic Systems



Unclassified

- Once each object is modeled, thus the scene is modeled, we can identify the intent based on prior information.
- Example: The intent of a person (O1) picking up an object (O2) and moving it to another location would be observed as: *O1 moves. O1 touches O2. O1 moves. O2 moves. O1 un-touches O2. O1 exits.*

Unclassified

14

Intent Analysis -IDS Radar

BAE SYSTEMS

GENERAL DYNAMICS
Robotic Systems



Unclassified

- Determine intruder motion
 - Range, range rate, bearing
 - Crawling, walking, running
 - Intruder tracks
- Used by the AMS to identify potential threats
- Future UGV systems may use this in conjunction with the FCS Common Operating Picture (COP).

Unclassified

15

Countermeasures (Tactical Behaviors)

BAE SYSTEMS

GENERAL DYNAMICS
Robotic Systems



Unclassified

- Layered Response
 - Dependent upon threat level as determined by intent analysis
- Responses
 - Aural warning/High-intensity spotlight
 - Start/Rev engine
 - Move away
 - Move toward
 - Point gun
 - Shoot (MILES)

Unclassified

16

Conclusion

BAE SYSTEMS

GENERAL DYNAMICS
Robotic Systems



Unclassified

- ART Survivability utilizes several key sensors to protect itself from hostile intentions by people – called Anti-tamper.
- Anti-tamper uses both visual (Visual Intent Analysis) and radar (IDS Radar) to determine intentions of possible hostiles.
- Anti-tamper will be demonstrated in two user experiments (Jun-07, and Feb-09).

Unclassified

17

Questions ???

BAE SYSTEMS

GENERAL DYNAMICS
Robotic Systems



Unclassified

Unclassified

18