

Electrically Driven General Systems for UAV's

Fokke Mentjes

EADS Deutschland GmbH

Defence & Security

Military Air Systems

81663 Munich, Germany

fokke.mentjes@eads.com

Abstract

The advancements in performance and reliability of high power semi-conductors make it possible to develop new system architectures for the general systems of the aircraft.

The electrification of classical systems like actuation or environment control systems allows, depending on the vehicle requirements, a system architecture with only electrical power supply. On the other hand the requirements for the electrical system increase drastically. It has not only to provide more electrical energy, but also in different power qualities and of increased voltage. The most important aspect for the electrical system design is that it is now the critical power source for the primary flight control system. Therefore, a very high reliability has to be part of the design.

On the equipment side the power distribution and power controlled equipment plays a major role in the ability to dispatch the available power in relation to flight phase or emergency cases. Modern motor control units allow to operate actuators, pumps or compressors with high efficiency. This allows to reduce the overall off-take power from the engine, the fuel consumption and the aircraft IR and radar signature (stealth design) or to increase endurance.

This paper discusses possible architectures of More Electric Aircraft as well as features and performance of equipment which was developed within the research programme.

1. Introduction

General systems are defined as the total of flight safety critical systems of an aircraft excluding the engine and flight control computing. Usually, the following list represents the main subsystems in a general system context. They include the electrical power generation and distribution system, the primary and secondary flight control actuation system, the hydraulic system, the environmental control system, the fuel system and the landing gear and brake system.

General systems of conventional aircrafts are operated with a variety of different sources of energy that include mechanical, thermal, hydraulic, pneumatic and electric energy. All those types of energy are generated, transferred, distributed and consumed by several sub-systems in different parts of the flight envelope. Due to high power conversion rates in only a small bandwidth of the overall flight envelope, low efficiency factors apply to most of the systems.

Mentjes, F. (2007) Electrically Driven General Systems for UAV's. In *UAV Design Processes / Design Criteria for Structures* (pp. 3.1-1 – 3.1-10). Meeting Proceedings RTO-MP-AVT-145, Paper 3.1. Neuilly-sur-Seine, France: RTO. Available from: <http://www.rto.nato.int/abstracts.asp>.

Report Documentation Page

*Form Approved
OMB No. 0704-0188*

Public reporting burden for the collection of information is estimated to average 1 hour per response, including the time for reviewing instructions, searching existing data sources, gathering and maintaining the data needed, and completing and reviewing the collection of information. Send comments regarding this burden estimate or any other aspect of this collection of information, including suggestions for reducing this burden, to Washington Headquarters Services, Directorate for Information Operations and Reports, 1215 Jefferson Davis Highway, Suite 1204, Arlington VA 22202-4302. Respondents should be aware that notwithstanding any other provision of law, no person shall be subject to a penalty for failing to comply with a collection of information if it does not display a currently valid OMB control number.

1. REPORT DATE 01 NOV 2007	2. REPORT TYPE N/A	3. DATES COVERED -			
4. TITLE AND SUBTITLE Electrically Driven General Systems for UAV's		5a. CONTRACT NUMBER			
		5b. GRANT NUMBER			
		5c. PROGRAM ELEMENT NUMBER			
6. AUTHOR(S)		5d. PROJECT NUMBER			
		5e. TASK NUMBER			
		5f. WORK UNIT NUMBER			
7. PERFORMING ORGANIZATION NAME(S) AND ADDRESS(ES) EADS Deutschland GmbH Defence & Security Military Air Systems 81663 Munic h, Germany		8. PERFORMING ORGANIZATION REPORT NUMBER			
9. SPONSORING/MONITORING AGENCY NAME(S) AND ADDRESS(ES)		10. SPONSOR/MONITOR'S ACRONYM(S)			
		11. SPONSOR/MONITOR'S REPORT NUMBER(S)			
12. DISTRIBUTION/AVAILABILITY STATEMENT Approved for public release, distribution unlimited					
13. SUPPLEMENTARY NOTES See also ADM202420., The original document contains color images.					
14. ABSTRACT					
15. SUBJECT TERMS					
16. SECURITY CLASSIFICATION OF:			17. LIMITATION OF ABSTRACT UU	18. NUMBER OF PAGES 10	19a. NAME OF RESPONSIBLE PERSON
a. REPORT unclassified	b. ABSTRACT unclassified	c. THIS PAGE unclassified			

Electrically Driven General Systems for UAV's

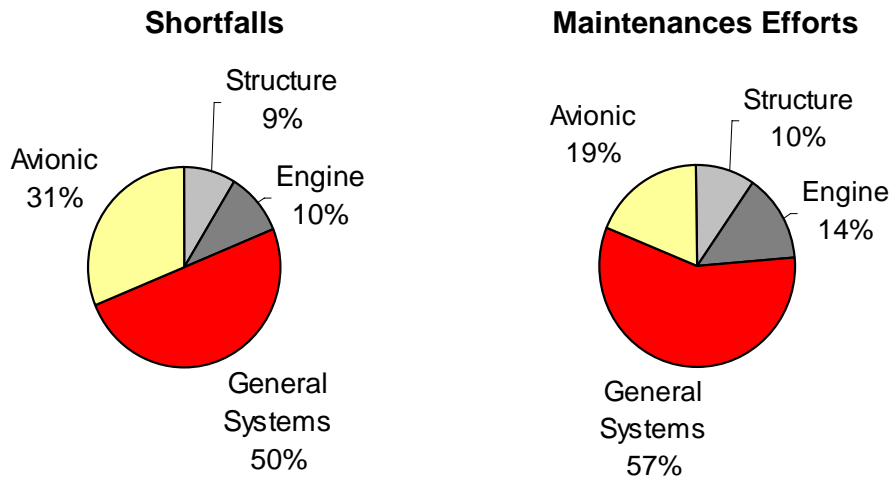

J. Nairus (WL / POOC), „More Electric Initiative Overview“, SAE-AE7, Phoenix AZ, 23.10.1996

Figure 1: Impact of conventional general systems design on shortfalls and maintenance efforts

In addition the range of use of dissimilar types of energy results in a complex system design with an extensive need for maintenance. Figure 1 shows the impact of conventional general systems design on shortfalls and maintenance efforts. According to the presented figures, 50% of all shortfalls on aircraft are caused by general systems and 57% of the maintenance efforts are referred to down and repair times of general systems.

2. General Systems Architecture

2.1 Conventional General Systems Architecture

The design of conventional general systems architecture includes the use of a variety of energies. Three main types of energy can be identified: electric, hydraulic and pneumatic energy, all converted from mechanical energy provided by the engine via gear boxes. Figure 2 shows a simplified conventional general systems architecture with three main types of energy.

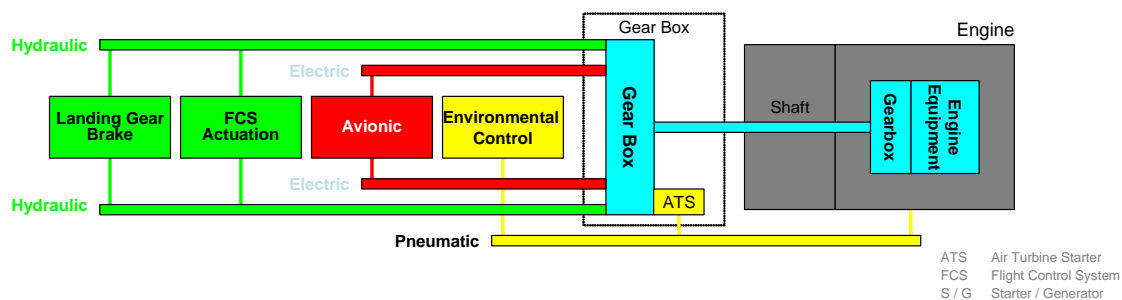

Figure 2: Conventional general systems architecture

Basically, a redundant electric power supply is used to support the avionic system including flight control computing and mission management. In addition, control and monitoring functions of general systems including different types of sensors are powered electrically as well. The power supply for the primary and secondary flight control actuation, landing gear and brake is accomplished with a redundant hydraulic system. The environmental control system used for cooling and pressurization of the avionic compartments is running with pneumatic power extracted from the engine. Furthermore, some systems' designs include an air turbine starter (ATS) that uses pneumatic power too.

For ground operation at an airbase, ground power equipment providing all three types of energy are necessary.

2.2 More Electric Aircraft

With the More Electric Aircraft concept hydraulic and pneumatic systems are replaced by electric systems. Similar to the conventional general systems as described above, a simplified architecture is used to explain the changes on the system. Figure 3 shows an example of a system architecture with electrically driven general systems in a single engine configuration.

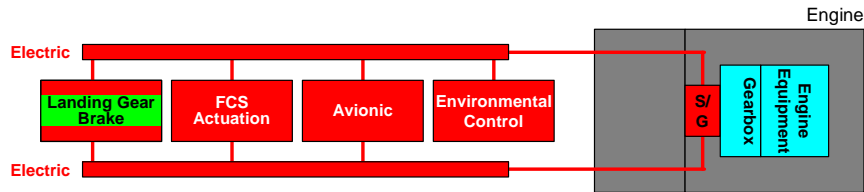

Figure 3: More Electric Aircraft: electrically driven general systems architecture

The power generation and distribution system delivers a redundant high electrical direct current of 270VDC from an integrated starter generator. The starter generator is incorporated on the main shaft of the engine without additional gear boxes. No other energy source except electric power is extracted from the engine.

All sub-systems such as primary and secondary flight control actuation, avionic and environmental control system are supplied with 270 VDC for high power applications, in parallel a conversion to 28 VDC is provided to run the control electronics. A change from pneumatic to electrical energy for the environmental control system implies the utilization of closed vapour cycles. The landing gear system might still include an electrically driven hydraulic power package to operate the gear during take off and landing, but will be switched off during flight. Nevertheless the brake system will be electrically driven.

Especially with the use of modern, high efficient electrical drives a less complex system design with declined power conversions is achievable. One benefit of higher efficiency will pay off in reduced infrared signatures of the overall aircraft.

As high direct currents cannot be switched with standard contactors and relays the use of solid state power contactors (SSPC) is essential. Those SSPC's can be mounted into a dedicated cabinet with a digital interface to the utility control computer to serve as a power distribution centre (PDC). This PDC will also replace conventional circuit breaker and their over current protection functionality. Depending on the phase of flight or on failure detection a prioritization of the power distribution is possible to offer a complex load management system. Moreover, the upcoming need to supply directed energy weapons will make a load management necessary.

From the operational point of view, fewer ground equipment, less operational supply items (including less spares) and less maintenance personnel are some of the benefits of the introduction of electrically driven general systems which leads to an improved relocation capability. In addition, maintenance efforts, detect ability of failures and long term storage will be improved.

Electrically Driven General Systems for UAV's

3. Research and Technology Projects

Two research and technology initiatives related to electrically driven general systems are discussed in this paper. First the Barracuda M-05 UAV Demonstrator and second the 270 VDC More Electric Aircraft project launched by the German *Federal Office of Defense Technology and Procurement* (BWB).

3.1 Barracuda M-05

The Barracuda M-05 is a company founded unmanned demonstrator vehicle, which serves as an integration platform for several UAV related technologies at EADS Military Air Systems. With a wing span of 7 meters, a take off weight of 3 tons and the capability to carry approximately 300 kg of different payloads, the vehicle is suitable to demonstrate a variety of different UAV missions. The fully autonomous first flight was performed in April 2006 in Spain. Unfortunately, this vehicle was lost in a later test flight. Figure 4 showed a picture of the first flight.



Figure 4: Barracuda M-05 First Flight

With respect to electrically driven general systems, the aircraft includes already the main aspects of the more electric aircraft architecture as described in chapter 2.2.. A redundant electrical power generation and distribution system serves as a backbone for the flight control, avionic and general systems. The control of the power distribution system is ensured by a digital utility control system with two remote interface units. Due to the lack of commercial/military off the shelf components, 28 VDC was chosen for the main supply. The flight control actuation system consists of electro-mechanical actuators and a separate power control unit and a signal control unit. All primary actuators operate in an active-active mode with both motors adding their forces. To ensure a reliable fail-operate-mode switch reluctant electrical motors were selected which can be switched off completely in failure cases.

Beside the primary flight control system also the fuel, environmental control and landing gear system were driven electrically. The landing gear system contains a hydraulic pump package that transfers electrical energy into hydraulic energy for extension and retraction of the landing gear. After retraction of the gear, the hydraulic system is switched off; therefore in

flight the aircraft uses just electric power to run all systems. For deceleration after landing an electrical brake with carbon heat packs is installed on aircraft.

New developed equipment such as the primary flight control actuation and the electrical brake contain a dedicated build-in test capability and a digital control and monitoring interface to the flight control computer.

Design, development and integration testing for the Barracuda M-05 UAV showed that increased attention to power supply characteristics as to be paid to guarantee a stable electrical generation and distribution.

3.2 270VDC MEA

The 270 VDC More Electric Aircraft project was launched in 2003 by the German *Federal Office of Defense Technology and Procurement* (BWB) to boost high power direct current technology on equipment and system integration level. The overall project is divided in a first phase from 2003 to 2006 to develop key equipment for electrically driven general systems and a second phase from 2007 to integrate the developed equipment in a full scale bench environment to investigate system aspects.

Three major system aspects are covered under the project in detail:

- Electrical 270 VDC onboard power generation and distribution
- Electro-mechanical actuation system
- Environmental and fuel system

3.2.1 Equipment Development

The following essential equipment was identified to be developed in the first phase of the project and will be discussed in this paper:

- 270 VDC to 28 VDC Converter
- 270 VDC Fuel Pump
- 270 VDC Starter Generator
- 270 VDC Electro-mechanical Actuator
- 270 VDC Generator

All equipment is specified, developed and qualified to be capable of being installed in a potential UAV platform in a next step. Nevertheless, some equipment has currently the status of a functional technology demonstrator.

3.2.2 270 VDC to 28 VDC Converter

Only high power application in UAV's will be operated with 270 VDC, standard avionic equipment will still require a 28 VDC power supply. Therefore, a converter from 270 VDC to 28 VDC was developed. The maximum constant output current of the converter is at 100 A at 28 VDC. Figure 5 shows a picture of the prototype converter developed by *Diehl Aerospace*.

Electrically Driven General Systems for UAV's

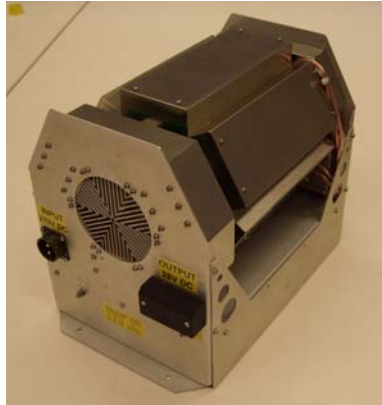

Figure 5: 270 VDC to 28 VDC Converter

3.2.3 270 VDC Fuel Pump

To supply the engine with fuel flow a tank mounted boost pump for 270 VDC supply was developed by *AOA Apperatebau Gauting GmbH*. The maximum power consumption of the single stage pump does not exceed 3 kW and it features a build in test software with failure detection. Figure 6 shows a picture of the 270 VDC boost pump developed and qualified for the project.



Figure 6: 270 VDC Fuel Boost Pump

3.2.4 270 VDC Starter Generator

In chapter 2.2., an integrated starter generator mounted directly on the main shaft of the engine was discussed. For the next generation of UAV's it is assumed that off-the-shelf engines will be used without this new technology. Therefore a 270 VDC starter generator was developed that can be integrated to a standard gear box flange. In addition, the system integration rig could be realized more easily. The starter generator operates as a motor during engine start and switches automatically to generator mode when the engine is running stably. A generator control unit includes the control algorithms, continuous build in test and a digital interface to the utility control computer. Due to safety requirements the starter generator uses state of the art switch reluctance technology. The power rating of the generator under continuous full load is at 12 kW. Figure 7 shows a picture of the starter generator and the generator control unit developed by *ESW*.



Figure 7: 270 VDC Starter Generator with Generator Control Unit

3.2.5 270 VDC Electro-mechanical Actuator

One of the new key elements of the more electric aircraft configuration is the introduction of electro-mechanical actuation systems for the primary flight control. High dynamic requirements under extreme aerodynamic loads are the design driver for the electric motors utilized in this application. In a force adding active-active mode with a fail-operate requirement in failure cases, lead to the use of switch reluctance motor technology. Those motor types could be switched off completely in any failure case.

A duplex actuator working in an active-active mode capable to provide operational forces up to 18 kN was developed by *Liebherr Aerospace*. The system contains an electro-mechanical actuator and a power and control electronics box. The electronics includes the entire control and monitoring functions of the actuator, power conversion and control of the two motors and a digital interface to the flight control computer. Figure 8 shows an outline drawing and a picture of the actuator.

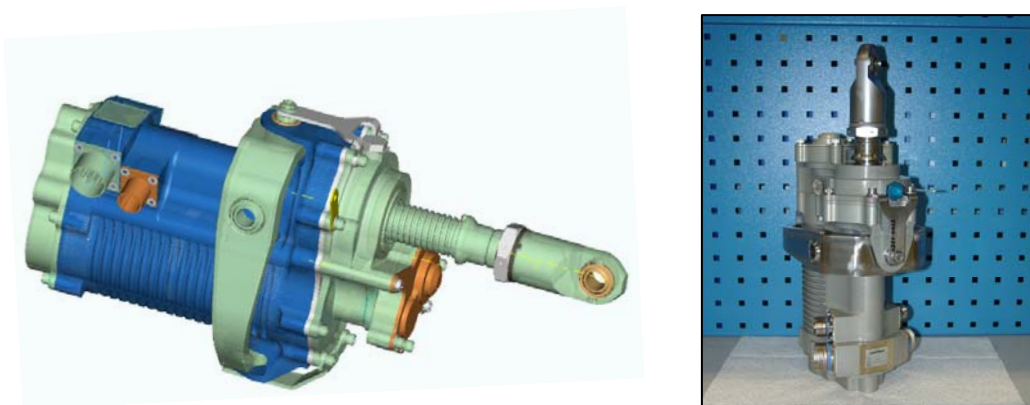

Figure 8: 270 VDC Electro-mechanical Actuator

3.2.6 270 VDC Generator

For a redundant power supply of UAV with a single engine configuration a second generator beside the starter generator is crucial. For the 270 VDC More Electric Aircraft project, a 6kW generator was developed by *Entrak*. Again, this generator includes a generator control unit with a digital interface to the utility control computer. The control unit covers all build-in tests, failure detection and automatic online/offline switching. Figure 9 shows the prototype of the generator during qualification testing.

Electrically Driven General Systems for UAV's



Figure 9: 270 VDC Generator

3.2.7 System Integration Test Rig

In 2007 the development and assembly of an integration test rig for the 270 VDC technologies has started. The rig will be established at the *University of Armed Forces* in Munich and comprises all equipment developed under the first phase of the project from 2003 to 2006. In addition, provisions are incorporated to extend the rig with other 270 VDC equipment. Figure 10 shows the architecture of a final stage of the integration test rig. Especially the interference of high power consumers under dynamic loads, such as actuation, on the power generation and distribution system will be investigated. First electrical 'Power On' is planned for autumn 2007.

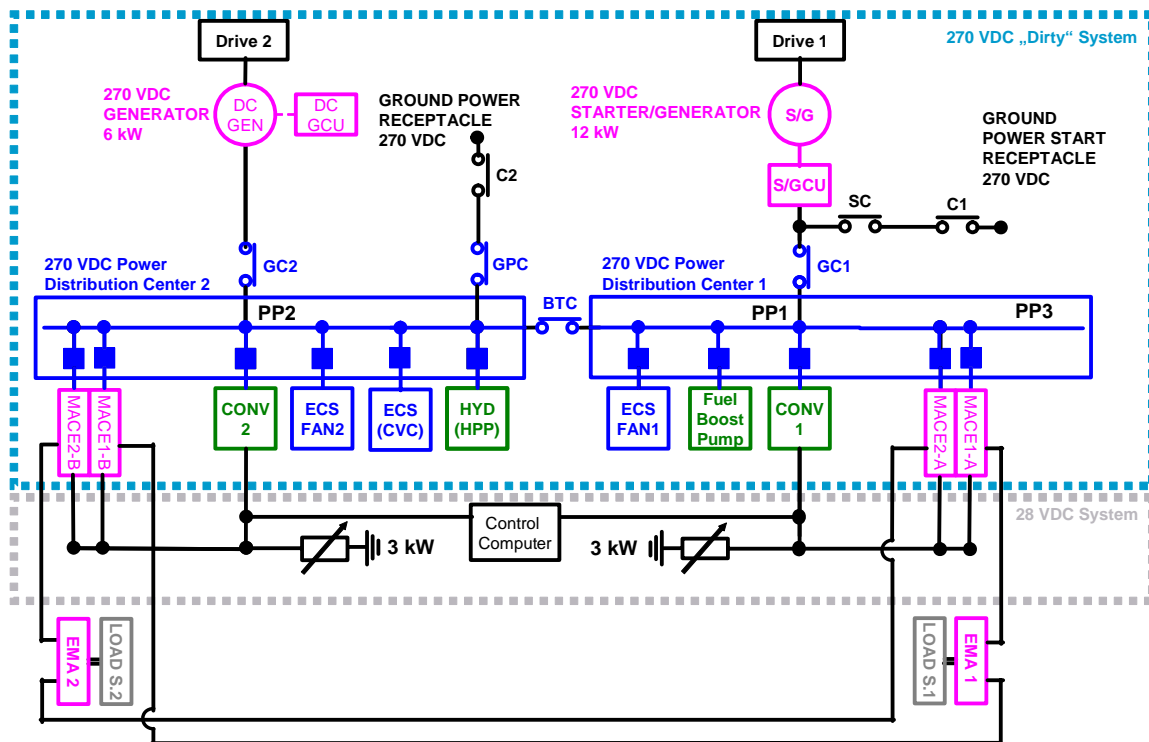

Figure 10: 270 VDC System Integration Rig

Basically, the rig is divided into two parts one for the 270 VDC system and one for the 28 VDC system.

The 270 VDC system is used to supply consumers with high power ratings under dynamic loads. It is expected that due to those dynamic consumers some voltage variations are expected. Therefore the system is classified as a 'dirty' system, which may not fully comply with standard MIL-704. The 12 kW starter generator and the 6 kW generator are incorporated with an industrial drive that provides mechanical energy comparable to a standard engine. Generated electrical power is dispatched to two power distribution centre that further distribute the power to the several consumers. Both power distribution centres are equipped with solid state power contactors including over current protection and a digital MIL bus interface to the utility control computer.

The starter generator is connected to PDC 1, which supplies an ECS fan, the fuel boost pump, one of the 28 VDC converter and the power and control electronics of one actuator. The second generator is connected to PDC2, which supplies a second ECS fan, the second converter, a hydraulic power package, a closed vapour cycle ECS pack and the second power and control electronics of the second actuator.

The 28 VDC system represents the avionic loads of the UAV. As those loads do not have high load variations two simple load resistors are utilized. The utility control computer is also connected to the 28 VDC bus bar.

Both electro-mechanical actuators are equipped with a load actuator for a representation of dynamic aerodynamic loads.

4. Summary

This paper gives an overview on the benefits and impacts of electrically driven general systems with respect to future UAV design.

Conventional general systems architectures are compared with more electric aircraft architectures and the impacts on a system's design, operational practice and other areas were highlighted.

Two major research and technology projects related to electrically driven general systems at EADS Military Air Systems were summarized. First, the Barracuda M-05 system architecture was described, second, the 270VDC More Electric Aircraft activates were explained in detail covering equipment development and the structure of a system integration rig.

5. Abbreviation List

ATS	Air Turbine Starter
BWB	Bundesamt für Wehrtechnik und Beschaffung (Federal Office of Defense Technology and Procurement)
CVC	Closed Vapour Cycle
DC	Direct Current
ECS	Environmental Control System
EMA	Electro-mechanical Actuator
FCS	Flight Control System
GCU	Generator Control Unit
HPP	Hydraulic Power Package
IR	Infrared
MACE	Motor and Actuator Control Electronics
MEA	More Electric Aircraft
PDC	Power Distribution Centre
S/G	Starter Generator
SSPC	Solid State Power Contactor
UAV	Unmanned Aerial Vehicle
UCS	Utility Control System