

THE INTERNATIONAL  
C2 JOURNAL

VOLUME 1, NUMBER 2, 2007

SPECIAL ISSUE

*Decision Support for Network-Centric  
Command and Control*

GUEST EDITOR

*Sandeep Mulgund, Ph.D.*  
*The MITRE Corporation*

Automation Architecture for Single Operator,  
Multiple UAV Command and Control

*M.L. Cummings*

*S. Bruni*

*S. Mercier*

*P.J. Mitchell*



# Report Documentation Page

Form Approved  
OMB No. 0704-0188

Public reporting burden for the collection of information is estimated to average 1 hour per response, including the time for reviewing instructions, searching existing data sources, gathering and maintaining the data needed, and completing and reviewing the collection of information. Send comments regarding this burden estimate or any other aspect of this collection of information, including suggestions for reducing this burden, to Washington Headquarters Services, Directorate for Information Operations and Reports, 1215 Jefferson Davis Highway, Suite 1204, Arlington VA 22202-4302. Respondents should be aware that notwithstanding any other provision of law, no person shall be subject to a penalty for failing to comply with a collection of information if it does not display a currently valid OMB control number.

1. REPORT DATE <b>2007</b>		2. REPORT TYPE		3. DATES COVERED <b>00-00-2007 to 00-00-2007</b>	
4. TITLE AND SUBTITLE <b>Automation Architecture for Single Operator, Multiple UAV Command and Control</b>				5a. CONTRACT NUMBER	
				5b. GRANT NUMBER	
				5c. PROGRAM ELEMENT NUMBER	
6. AUTHOR(S)				5d. PROJECT NUMBER	
				5e. TASK NUMBER	
				5f. WORK UNIT NUMBER	
7. PERFORMING ORGANIZATION NAME(S) AND ADDRESS(ES) <b>Massachusetts Institute of Technology, Humans &amp; Automation Laboratory, 77 Massachusetts Avenue, Cambridge, MA, 02139</b>				8. PERFORMING ORGANIZATION REPORT NUMBER	
9. SPONSORING/MONITORING AGENCY NAME(S) AND ADDRESS(ES)				10. SPONSOR/MONITOR'S ACRONYM(S)	
				11. SPONSOR/MONITOR'S REPORT NUMBER(S)	
12. DISTRIBUTION/AVAILABILITY STATEMENT <b>Approved for public release; distribution unlimited</b>					
13. SUPPLEMENTARY NOTES					
14. ABSTRACT					
15. SUBJECT TERMS					
16. SECURITY CLASSIFICATION OF:			17. LIMITATION OF ABSTRACT	18. NUMBER OF PAGES	19a. NAME OF RESPONSIBLE PERSON
a. REPORT <b>unclassified</b>	b. ABSTRACT <b>unclassified</b>	c. THIS PAGE <b>unclassified</b>			

# THE INTERNATIONAL C2 JOURNAL

David S. Alberts, Chairman of the Editorial Board, *OASD-III, CCRP*  
Joseph R. Lewis, Managing Editor

## The Editorial Board

---

Berndt Brehmer (SWE), *Swedish National Defence College*  
Reiner Huber (GER), *Universitaet der Bundeswehr Muenchen*  
Viggo Lemche (DEN), *Danish Defence Acquisition and Logistics Organization*  
James Moffat (UK), *Defence Science and Technology Laboratory (DSTL)*  
Mark Nissen (USA), *Naval Postgraduate School*  
Ross Pigeau (CAN), *Defence Research and Development Canada (DRDC)*  
Mink Spaans (NED), *TNO Defence, Security and Safety*

## Associate Editors

---

Gerard Christman, *U.S. OSD Technical Services - Femme Comp Inc.*  
R. Scott Cost, *Johns Hopkins University Applied Physics Laboratory*  
Raymond J. Curts, *Strategic Consulting, Inc*  
Paul K. Davis, *RAND Corporation*  
Petra M. Eggenhofer, *Munich Bundeswehr University*  
Elliot Entin, *Aptima*  
Stuart Grant, *Defence Research and Development Canada (DRDC)*  
Juergen Grosche, *FGAN-FKIE, Germany*  
Paul Labbé, *Defence Research and Development Canada*  
Michael Malm, *Swedish Defence Research Agency*  
Sandeep Mulgund, *The MITRE Corporation*  
Philip W. Pratt, *Northrop Grumman*  
Jens Roemer, *Fachschule der Bundeswehr für Informatiktechnik*  
Pamela Savage-Knepshield, *U.S. Army Research Laboratory, Human Research & Engineering Directorate*  
Keith Stewart, *Defence Research and Development Canada (DRDC)*  
Andreas Tolk, *Old Dominion University*

## About the Journal

---

The International C2 Journal was created in 2006 at the urging of an international group of command and control professionals including individuals from academia, industry, government, and the military. The Command and Control Research Program (CCRP, of the U.S. Office of the Assistant Secretary of Defense for Networks and Information Integration, or OASD-NII) responded to this need by bringing together interested professionals to shape the purpose and guide the execution of such a journal. Today, the Journal is overseen by an Editorial Board comprising representatives from many nations.

Opinions, conclusions, and recommendations expressed or implied within are solely those of the authors. They do not necessarily represent the views of the Department of Defense, or any other U.S. Government agency.

**Rights and Permissions:** All articles published in the International C2 Journal remain the intellectual property of the authors and may not be distributed or sold without the express written consent of the authors.

## For more information

---

Visit us online at: [www.dodccrp.org](http://www.dodccrp.org)

Contact our staff at: [publications@dodccrp.org](mailto:publications@dodccrp.org)





# Automation Architecture for Single Operator, Multiple UAV Command and Control

*M.L. Cummings,<sup>1</sup> S. Bruni, S. Mercier, and P.J. Mitchell*

## Abstract

In light of the Office of the Secretary Defense's Roadmap for unmanned aircraft systems (UASs), there is a critical need for research examining human interaction with heterogeneous unmanned vehicles. The OSD Roadmap clearly delineates the need to investigate the "appropriate conditions and requirements under which a single pilot would be allowed to control multiple airborne UA (unmanned aircraft) simultaneously." Toward this end, in this paper, we provide a meta-analysis of research studies across unmanned aerial and ground vehicle domains that investigated single operator control of multiple vehicles. As a result, a hierarchical control model for single operator control of multiple unmanned vehicles (UV) is proposed that demonstrates those requirements that will need to be met for operator cognitive support of multiple UV control, with an emphasis on the introduction of higher levels of autonomy. The challenge in achieving effective management of multiple UV systems in the future is not only to determine whether automation can be used to improve human and system performance, but how and to what degree across hierarchical control loops, as well as determining the types of decision support that will be needed by operators given the high-workload environment. We address when and how increasing levels of automation should be incorporated in multiple UV systems and dis-

---

1. Contact author: MIT, 77 Massachusetts Ave, 33-305, Cambridge, MA 02139, missyc@mit.edu

cuss the impact on not only human performance, but more importantly, on system performance.

**Keywords:** multiple unmanned aerial vehicles, supervisory control, operator capacity

## **Introduction**

Unmanned aerial vehicles (UAVs) are quickly becoming ubiquitous in military command and control operations. With reduced radar signatures, increased endurance, and the removal of humans from immediate threat, unmanned (also known as uninhabited) aerial vehicles have become indispensable assets to militarized forces around the world, as proven by the extensive use of the Shadow and Predator in recent conflicts. Despite the absence of a crew onboard any of these UAVs, human operators are still needed for supervisory control.

UAVs require human guidance to varying degrees and often through several operators, which is what essentially defines a UAS (Unmanned Aerial System). For example, the Predator and Shadow each require a crew of two to be fully operational. However, with current military focus on streamlining operations and reducing manning, there has been an increasing effort to design systems such that the current many-to-one ratio of operators to vehicles can be inverted. In light of the Office of the Secretary of Defense Roadmap for UASs (2005), there is a critical need for research examining human interaction with multiple UASs, which has also recently been identified as an essential need by the Committee on Autonomous Vehicles in Support of Naval Operations (Naval Studies Board 2005).

In response to this need, this paper first defines human supervisory control of one and multiple UAVs. It then analyzes past literature to examine potential trends in supervisory control research of multiple UAVs. Specific attention is paid to automation strategies for deci-

sionmaking and action as levels of embedded automation significantly differ between applications. We will demonstrate that as autonomy increases across hierarchical control loops, the number of vehicles a single operator can control also increases. However, as we will discuss, increasing system autonomy can introduce negative consequences in term of operator situation awareness and complacency. The focus of this paper is primarily on human supervisory control of multiple UASs, with a discussion of broader command and control implications. However, the reader is referred to (Alberts et al. 1999; Alberts & Hayes 2006; Curtis & Frizzell 2005; Bolia et al. 2006) for more detailed discussions about other socio-technical implications of automation and network-centric operations in command and control domains.

## **Supervisory Control of Multiple UAVs**

The move from platform-centric warfare to Network Centric Warfare (NCW) represents a shift in the role of humans both in mission planning and actual operation. As has already been evidenced in the development of fly-by-wire, highly automated aircraft, and missile systems (such as Tomahawk and Patriot), military operators are less in direct manual control of systems, but more involved in the higher levels of planning and decisionmaking and remote operations. This shift in control from lower level skill-based behaviors to higher level knowledge-based behaviors is known as human supervisory control (HSC). HSC is the process by which a human operator intermittently interacts with a computer, receiving feedback from and providing commands to a controlled process or task environment, which is connected to that computer (Figure 1) (Sheridan 1992). All UAVs in the DoD inventory operate at some level of supervisory control as depicted in Figure 1.

Human supervisory control in UAV operation is hierarchical, as represented in Figure 2. The innermost loop of Figure 2 represents the basic guidance and motion control, which is the most critical loop that must obey physical laws of nature such as aerodynamic



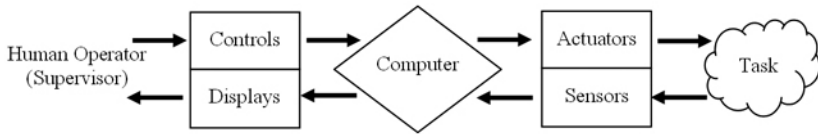

**Figure 1. Human Supervisory Control (Sheridan 1992).**

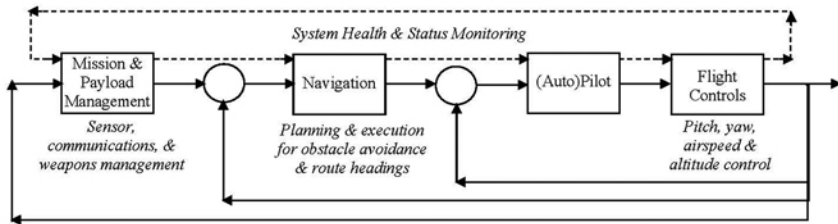

**Figure 2. Hierarchical Control Loops for a Single UAV.**

constraints for UAVs. In this loop, operator actions are focused only on the short term and local control (keeping the aircraft in stable flight), and generally human control in this loop requires skill-based behaviors that rely on automaticity (Rasmussen 1983).

The second loop, the navigation loop, represents the actions that some agent, whether human or computer-driven, must execute to meet mission constraints such as routes to waypoints, time on targets, and avoidance of threat areas and no-fly zones. The outermost loop represents the highest levels of control, that of mission and payload management. In this loop, sensors must be monitored and decisions made based on the incoming information to meet overall mission requirements. In this loop, decisions require knowledge-based reasoning that includes judgment, experience, and abstract reasoning that in general cannot be performed by automation.

Finally, the system health and status monitoring loop in Figure 2 represents the continual supervision that must occur, either by a human or automation or both, to ensure that all systems are operat-

ing within normal limits. The control loop line is dashed as it represents a highly intermittent loop in terms of the human, i.e., if the human is engaged in another task, with the highest priority given to the innermost loop, health and status monitoring becomes a distant, secondary task.

From the human-in-the-loop perspective, if the inner loops fail, then the higher (outer) loops will also fail. The dependency of higher loop control on the successful control of the lower loops drives human limitations in control of a single and especially multiple UAVs. If humans must interact in the guidance and motion control loop (hand fly a UAV), the cost is high because this effort requires significant cognitive resources. What little spare mental capacity is available must be divided between the navigation and mission management control loops. Violations of the priority scheme represented in Figure 2 have led to serious problems exemplified by numerous Predator crashes. When operators become cognitively saturated or do not correctly allocate their cognitive resources to the appropriate control loops in the correct priorities, they violate the control loops constraints, potentially causing catastrophic failure.

While Figure 2 demonstrates supervisory control at the single vehicle level, Figure 3 represents a notional system architecture that will be required for single operator control of multiple UASs. In order to achieve this futuristic system, operators will need to interact with an overall mission and payload manager while relegating routine navigation and motion control tasks to automation. The challenge in achieving effective management of multiple UAVs in the future is not only to determine if automation can be used to reduce workload, but how and to what degree in each of the control loops in Figures 2 and 3, as well as what kinds of decision support will be needed by operators given the high-workload environment. Moreover, the depiction of a single mission and payload management system for multiple vehicles as seen in Figure 3 is not just specific to UASs, as any vehicle—manned or unmanned, above or on the ground, or under water—can be a node under a common mission management system. Thus research that advances single operator,

multiple UAV command and control capabilities will actually set the stage for the implementation of NCW concepts in general.

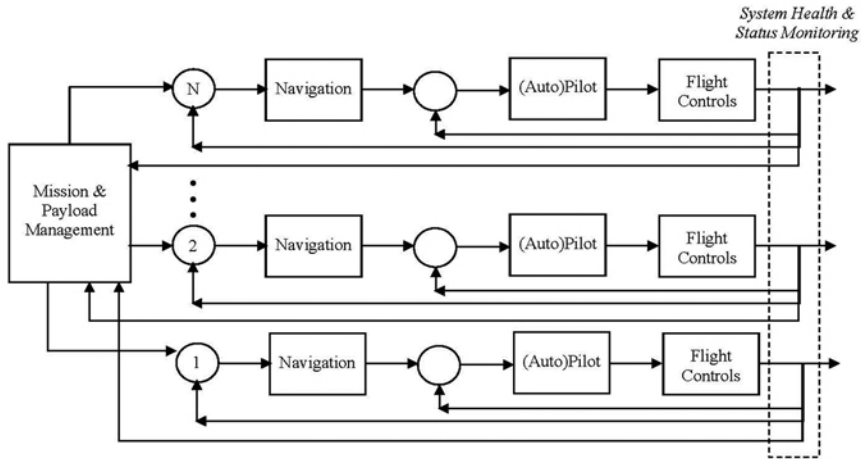

**Figure 3. Hierarchical Control for Multiple Unmanned Vehicles.**

### Levels of Automation

Increasing the autonomy across the three control loops discussed previously (Figures 2 and 3) is the critical architecture component for allowing one or a small team of operators to effectively control multiple UAVs. By increasing UAS autonomy, operator workload will theoretically be reduced as it could reduce the number of tasks for the operator, and it should reduce the level of interaction even at the highest levels of control in Figures 2 and 3. For example, those UAVs that are flown in an autopilot mode relieve the operator from the manual flying tasks that require significant cognitive resources. This frees the operator to perform other critical tasks like mission planning and imagery analysis.

Higher levels of automation across the control loops depicted in Figures 2 and 3 will be critical in achieving the single operator, multiple UAV control vision; but how, when, where, and what level of automation should be introduced are still difficult problems. While

workload mitigation can occur through increasing automation, it can inadvertently cause higher workload as well as loss of situational awareness, complacency, and skill degradation (Parasuraman et al. 2000). For example, some UAV researchers have found that intermediate levels of management-by-consent (automation as an assistant to the operator) is preferable to manual or more fully automated control (Ruff et al. 2002). However, management-by-consent means that the number of tasks could be high since operators must always be in the loop, potentially saturating operators, especially in the multiple UAV domain. Moreover, as has been shown in multiple UAV control research, operator performance can dramatically decrease under management-by-consent given increasing workload and various decision aids (Cummings et al. 2007a; Cummings & Mitchell 2006).

Given that an increasing number of tasks will have to be automated to achieve single operator control of multiple UAVs, the question then becomes what to allocate to automation. Previous research has demonstrated that in the scheduling and execution of high-level tasks, of multiple UAVs, management-by-exception can improve operator performance (Cummings & Mitchell 2006). Management-by-exception occurs when automation decides to take an action based on some set of pre-determined criteria, and only gives operators a chance to veto the automation's decision. While this control scheme can be effective in time-critical, high-risk domains like shutting down a near-critical reactor, in intentional, highly uncertain domains like command and control, it can be dangerous. Under this control scheme, operators are more likely to exhibit automation bias, a decision bias that occurs when operators become over-reliant on the automation and do not check to ensure automated recommendations are correct (Mosier & Skitka 1996).

Automation bias was operationally seen in the 2004 war in Iraq when the U.S. Army's Patriot missile system, operating in a management-by-exception mode, engaged in fratricide, shooting down a British Tornado and an American F/A-18, killing three. The sys-

tem was designed to operate under management-by-exception and operators were given approximately 15 seconds to veto a computer solution. Unfortunately the displays were confusing and often incorrect, and operators admittedly lacked training in the highly complex system (32nd Army 2003). Given the laboratory evidence that given an unreliable system, humans are still likely to approve computer-generated recommendations (Cummings 2004), it is not surprising that under the added stress of combat, Patriot operators did not veto the computer's solution. Automation bias is a significant concern for command and control systems so it will be critical to ensure that when higher levels of automation are used, especially at the management-by-exception level, that this effect is minimized.

### **A Meta-Analysis of Previous Multiple UAV Studies**

There have been numerous research studies published that have examined various aspects of multiple UAV control. We performed a meta-analysis across those studies that focused either explicitly on operator capacity or human supervisory control aspects of multiple vehicle control in order to determine any significant trends or lessons learned, particularly in regards to levels of automation and the control loops discussed above.

#### *Case Study Summaries*

One solution investigated by Dixon et al. to reduce UAV operator workload in the control of one or more (small) UAVs, such as the Shadow, consisted of adding auditory and automation aids to support the potential single operator (Dixon et al. 2005). They showed that a single operator could theoretically fully control a single UAV (both navigation and payload) if appropriate offloading strategies were provided. For example, aural alerts improved performance in the tasks related to the alerts, but not others. Conversely, it was also shown that adding automation benefited both tasks related to automation (e.g., navigation, path planning, or target recognition) as well

as non-related tasks. However, their results demonstrate that human operators may be limited in their ability to control multiple vehicles that need navigation and payload assistance, especially with unreliable automation. These results are concordant with the single-channel theory, stating that humans alone cannot perform high-speed tasks concurrently (Welford 1952; Broadbent 1958). However, Dixon et al. propose that reliable automation could allow a single operator to fully control two UAVs.

Reliability and the related component of trust is a significant issue in the control of multiple uninhabited vehicles. Ruff et al. (2002) found that if system reliability decreased in the control of multiple UAVs, trust declined with increasing numbers of vehicles but improved when the human was actively involved in planning and executing decisions. These results are similar to those found by Dixon et al. (2004) in that systems that cause distrust reduce operator capacity.

In addition, Ruff et al. (2002; 2004) determined that higher levels of automation actually degraded performance when operators attempted to control up to four UAVs. Results showed that management-by-consent (in which a human must approve an automated solution before execution) was superior to management-by-exception (where the automation gives the operator a period of time to reject the solution). Management-by-consent appeared to provide the best situation awareness ratings, the best performance scores, and the most trust for controlling up to four UAVs.

Dunlap et al. (2006) also subscribe to management-by-consent in their development of a distributed architecture to control multiple unmanned combat aerial vehicles (UCAVs). In this system, a UCAV plan is proposed by the automation and the operator can either accept or reject the plan or submit an alternative. This recommendation can include both target assignments and routing. While they tested four, six, and eight UCAVs with increasing levels of environmental complexity, their final design limited the UCAV loadout at four. In one experiment, they noted that automation bias was a prevalent problem, stating the operators “had become attenuated to

automatically accepting the usually correct proposals from the UCAVs,” which resulted in an increased kill rate for no-targets under the higher levels of automation.

In terms of actually predicting how many UAVs a single operator can control, there are only a few studies that examine this question. Cummings and Guerlain (2007) showed that operators could experimentally control up to twelve Tactical Tomahawk Land Attack Missiles (TLAM) given significant missile autonomy. Operators only had to interact in the mission management loop and all other loops were highly automated. In a UCAV setting, Cummings et al. (in press; 2007b) demonstrated that the number of UCAVs that a single operator can control is not just a function of the level of decision support automation, but also the operational tempo and demands. Operators under low workload performed well regardless of the level of decision support but under high workload, performance degraded. When considering operational and workload demands for a suppression of enemy air defenses mission, operator capacity was estimated at five UCAVs.

In a demonstration of the capabilities of a single operator attempting to control multiple Wide Area Search Munitions (WASMs), given high levels of autonomy across all control loops in Figure 3 with only higher-order goal tasking for mission management, Lewis et al. posit that an operator can effectively control up to eight WASMs (2006). The assumption is that the automation embedded in the vehicles coordinates, without human intervention, specific tasks such as target detection, choice of the most appropriate member to execute the mission, etc., which are capabilities that are not yet operational. The WASM study is similar to the Tactical Tomahawk study in that all flight control and navigation functions are allocated to the automation alone and the human intervenes for very high-level goal management.

Thus there have been a cross-section of studies that have examined operator performance and capacity in the control of multiple UAVs; however, it is not clear how any meaningful comparisons can be

made across the different domains primarily because of two parameters: (1) what constitutes *control* and (2) what level of automation was used to aid the operators? In order to more directly compare these studies, the following section will discuss the scale on which comparisons can be made.

### *Level of Automation Trends*

In this meta-analysis, we extracted the maximum number of UAVs that an operator effectively controlled in each study. It should be noted that in all of these reported studies, the control occurred in simulated test beds of medium-to-high fidelity. We identified what we interpreted to be the approximate levels of automation (LOAs) across the control loop(s) from Figure 3. While numerous levels and scales of automation and autonomy have been proposed (Parasuraman et al. 2000; Endsley & Kaber 1999; Wickens et al. 1998; Endsley 1995), we chose the ten-level scale originally proposed by Sheridan and Verplank (1978) (SV - LOA), as this is a commonly referenced taxonomy. We combined some categories in Table 1 to reflect functional similarities. For example, levels 7–10 were combined since the human can take no action. Recognizing that different stages of information processing can be supported by automation (Parasuraman et al. 2000), the decision and action selection stage is represented in our assessment.

In Table 2, which presents a summary of these findings, the numbers of UAVs potentially controllable by a single human operator are referenced along with estimated levels of automation for each of the three control loops (MC = Motion Control inner loop; N = Navigation; MM = Mission Management outer loop.). It should be emphasized that the LOAs selected were approximate since they were both subject to interpretation and assigned post hoc from studies not originally intended to answer our research question. In addition, in many simulations, the LOA was not fixed and we have indicated the range of LOAs in these cases. In this comparison, we also included an air traffic control (ATC) study since it embodies



many of the same principles of human supervisory control that are relevant to the control of multiple UAVs (Hilburn et al. 1997). Since air traffic controllers' primary focus is safe navigation of aircraft, there is no associated mission management control loop.

**Table 1. Levels of Automation.**

<b>SV - LOA</b>	<b>Our LOA</b>	<b>Automation Description</b>
1	I	The computer offers no assistance; human must take all decisions and actions.
2	II	The computer offers a complete set of decision/action alternatives.
3	III	The computer offers a selection of decisions/actions.
4/5	IV	The computer suggests one alternative and executes that suggestion if the human approves (management by consent).
6	V	The computer suggests one alternative and allows the human a restricted time to veto before automatic execution (management by exception).
7/8/ 9/10	VI	The human is not involved in the decisionmaking process; the computer decides and executes autonomously.

Table 2 reveals interesting trends. Without explicitly discussing it in their respective studies, all researchers automated the inner motion control loop as depicted in Figures 2 and 3. Thus some form of autopilot was needed to relieve operator workload and free cognitive resources for higher loop control. To achieve the goal of one person controlling many UAVs, operators should only monitor the piloting/maneuvering of the vehicle, not do it themselves. However this is a cultural problem more than it is a technological problem, as this technology is available today in all UAVs, but resisted in some communities, i.e., some organizations still insist that a human “fly” the vehicle instead of commanding it using various flight profiles.

**Table 2. Multiple UAV Study Comparison.**

	<b>Experiment</b>	<b>LOA</b>			<b>Max UV#</b>
		<b>MC</b>	<b>N</b>	<b>MM</b>	
1	Dixon et al. (2005) (baseline)	VI	I	I	1
2	Dixon et al. (2005) (autopilot)	VI	IV	I	2
3	Dixon et al. (2005) (auto-alert)	VI	I	IV	2
4	Ruff et al. (2002; 2004)	VI	IV-V	IV	4
5	Dunlap (2006)	VI	IV	IV	4
6	Cummings et al. (in press; 2007b)	VI	IV	III-IV	5
7	Lewis et al. (2006)	VI	VI	IV-V	8
8	Cummings & Guelain (2007)	VI	VI	IV	12
9	Hilburn et al. (1997) (ATC Study)	VI	V	N/A	11

In addition, Figure 4a demonstrates a general increasing trend in the number of vehicles an operator can control as a function of increasing automation in the navigation control loop of Figure 2. Thus given increasing navigation support and a fully autonomous flight control system, operators can handle more UAVs when they do not have to attend to local and even global navigation concerns. The highest operator capacity was seen in the Tomahawk missile and WASM domains because, as they are one-way UAVs traveling at high speeds, there is little time and fuel for human interaction beyond high-level goal direction.

When examining the mission and payload management control loop, Figure 4b demonstrates the ability of operators to control more vehicles as they are provided with increasing automated decision support. It is interesting to note that given some automated navigation assistance and management-by-consent automation in the mission management loop, there is a convergence of operator capacity at 4–5 vehicles per operator. The next remarkable increase

in operator capacity (8–12 vehicles) is not seen until management-by-exception is introduced in the mission management or navigation loops. These increased levels of automation will be critical for increased operator capacity since, as previously discussed, if operators are required to attend to local navigation functions, they simply do not have the cognitive resources to successfully attend to all of the tasks in the mission and payload management loop.

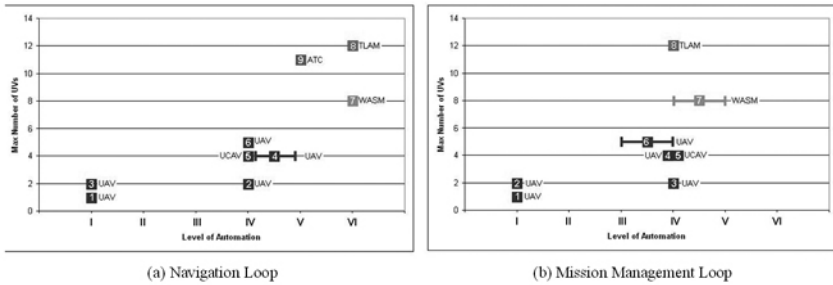

**Figure 4. Max Number of UAVs vs. LOAs for the (a) Navigation Loop and (b) Mission Management Loop.**<sup>2</sup>

One important consideration not evaluated here (primarily due to lack of any experimental evidence) is the impact of heterogeneous UAV control. While all the studies included in this review were homogeneous (except for the ATC study), the future of UAV operations will include mixed operations such that potentially different UAV platforms will interact in the same airspace. In addition, another important variable is that operators never manage multiple vehicles in isolation and are part of a larger team, so this effort needs to be extended to collaborative teaming environments.

Our purpose in relating prior multiple UAV human-in-the-loop studies is not to make claims about a specific theoretical maximum for a given LOA, but rather to illustrate the possibility that, with increasing automation in the motion control and navigation loops

2. The numbers for each data point match the study numbers in Table 2.

and collaborative decision support for the mission management loop, it is likely that operators can control an increasing number of UAVs. Table 2 and Figure 4 represent approximate generalizations and both automation decision support and subsequent display design can significantly alter human performance (Cummings et al. 2007a; Smith et al. 1997).

### *Linking Operator Capacity Estimates with Performance Parameters*

One of the limitations common across the previously reviewed studies is the lack of measurable performance metrics. In general, the performance of the operators was deemed acceptable as a function of expert observation, which is a valid method for performance assessment (Endsley & Garland 2000), but is not generalizable across domains and not useful for predictions as it is essentially a descriptive operator capacity prediction. Thus, what is needed is some kind of performance metric that captures both aspects of human and system performance, which indicates an objective level of goodness and/or satisficing (Simon et al. 1986) (i.e., a “good enough” solution as opposed to optimal.) Indeed, the focus on key performance parameters (KPPs) is a major focus for the Department of Defense, particularly in terms of network-centric command and control (Joint Chiefs 2007).

Research is currently underway to address this disconnect between operator capacity and performance, which has resulted in the development of many possible KPPs. A recent study demonstrated that the number ofUCAVs that a single operator can control is not just a function of the level of decision support automation, but is inextricably tied to both mission complexity and overall system performance (Cummings et al. 2007b). Using human experimentation in a multipleUCAV simulation test bed and a simulated annealing (SA) technique for heuristic-based optimization, operator performance was predicted to be significantly degraded beyond approximately fiveUCAVs, with an optimal bound between two and four vehicles (Figure 5). The KPP in this model was cost, which took into

account not just operational costs such as fuel, but also the cost of missed targets and cost in terms of mission delays introduced by inefficient human interactions. The solid curve in Figure 5 represents a theoretically perfect human operator, and the dotted line represents more realistic human performance that accounts for delays due to inefficient decisionmaking, communication problems, cognitive load, etc. Thus, the performance of the system (the automation and the operator) can vary as a function of the operator, but can also vary due to the operational constraints such as number of targets, operational costs, etc. This variation is why it is important to explicitly link system performance to operator capacity.

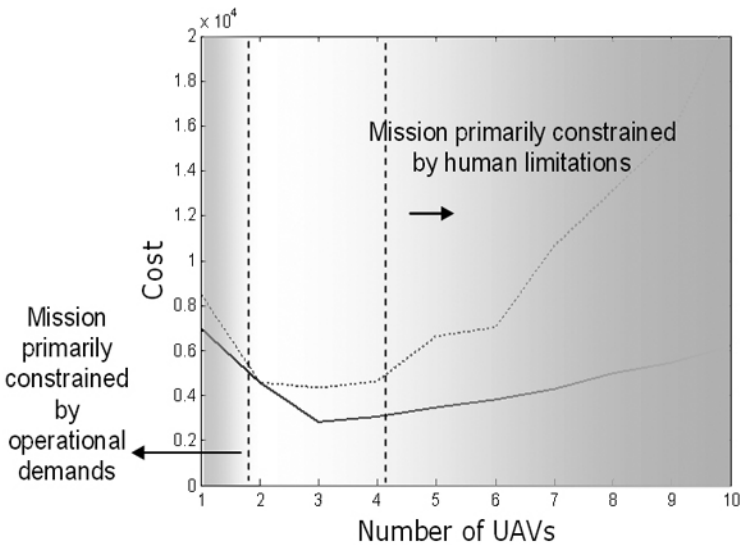

**Figure 5. Operator Capacity as a Function of Mission Constraints.**

### *Reliability and Trust*

Human operator interaction and performance using automated decision support agents have been shown to be significantly influenced by system reliability and resultant (dis)trust, i.e., the more reliable automation is, the more trust users have and the more likely they are to use the automation (Lee & Moray 1992; Lee & Moray

1994; Parasuraman 1993). Conversely, systems with poor or inconsistent reliability will often be disregarded (Parasuraman & Riley 1997; Riley 1994). This is especially true in C2 supervisory control systems where operators are multitasking while monitoring various mission-critical automated systems. High reliability may lead to overtrust, automation bias, complacency, and loss of situation awareness. Degraded reliability can lead to undertrust, misuse, and disuse of automation (Cummings & Mitchell 2006; Parasuraman & Riley 1997; Cummings 2004; Parasuraman et al. 1993).

Of the studies reviewed here, only a few examined the impact of trust and reliability. Addressing reliability, Ruff et al. (2002; 2004) concluded that performance decreases observed in low reliability conditions was, in part, due to lower trust in the automated decision-aid provided to the human operator. This was especially true as the number of vehicles per operator increased. Examining trust, Dixon and Wickens et al. (2005; 2004) investigated the effect of perfectly reliable versus degraded automation on performance in multi-UAV monitoring tasks. They concluded that reliable automation could alleviate task interference and reduce workload, and allow a single operator to control several UAVs. However, even perfectly reliable automation could not prevent a decrease in performance when workload increased.

### *Broader Command and Control Implications*

While the focus of this paper is primarily on human supervisory control of multiple UASs, there are many parallels across more general command and control settings, particularly for network-centric operations. At a more fundamental level, the multiple vehicle supervisory control paradigm represents an attention allocation problem that requires an operator to determine how and when to allocate limited cognitive resources to multiple, often competing tasks. Thus a single operator controlling multiple unmanned vehicles is analogous to command and control tasks in time-pressured, uncertain, and dynamic settings that concurrently

compete for operator attention. For example, in many cases there is a negative impact on primary task performance when military personnel attempt to attend to multiple chat streams, particularly in operations centers (Caterinicchia 2003; Boiney 2005; Heacox 2003), indicating that operators are struggling with attention allocation, especially in task prioritization.

For the multiple unmanned vehicle problem, as well as more general problems like chat management, operator capacity may ultimately be limited by the heterogeneity, as opposed to being strictly limited by the number of vehicles/tasks under control. Research is currently underway to determine the impact of task heterogeneity as opposed to vehicle and payload heterogeneity (Kilgore et al. 2007), as well as the development of a class of metrics to measure attention allocation efficiency (Crandall & Cummings in press).

The move towards network-centric operations will mean that operators must deal with many competing sources of incoming information, which could easily overload their cognitive bandwidth. Thus, research investigating operator capacity limits both from a vehicle and task heterogeneity perspective is critical not just for multiple unmanned vehicle control, but also for those command and control settings that require operators to make critical decisions with multiple sources of time-sensitive information.

## **Conclusion**

In response to the OSD UAS Roadmap and the future vision of NCW, a number of defense industries are now investigating and developing possible platforms and workstations to enable single operator control of multiple UAVs. For example, QinetiQ recently demonstrated that multiple self-organizing UAVs can be effectively controlled by an operator flying on a fast jet. Lockheed Martin has developed a prototype control station that not only allows for single operator control of multiple UAVs, but unmanned ground vehicles

as well. Raytheon's Universal Control System is advertised as providing single operator control of multiple UASs, simultaneously.

Despite the aggressive development of these multiple UAV/UAS control technologies, as we have demonstrated here, the research community is only beginning to grasp the nuances of human interaction in the cognitively demanding environment of multiple vehicle control. While this meta-analysis suggests promising trends—in that with increasing automation across all three control loops, it is likely that operators can control an increasing number of UAVs—the actual number will depend on a variety of other factors (system reliability, communication bandwidth, mission context, complexity, operational tempo, operator training, etc.).

In addition, as previously discussed, one serious drawback to the insertion of high levels of autonomy in the command and control of UAVs is the strong possibility that automation bias could lead to complacency and erroneous, if not catastrophic, outcomes. This decision bias has not only been seen in many experimental command and control settings (Cummings 2004; Dunlap 2006), but also in reality in the recent Gulf War conflict (32nd Army 2003). Thus, this possible negative outcome of increasing autonomy presents designers of both the technology as well as the encompassing organizational structures with a challenge: How to design reliable and trustworthy automated systems that reduce operator workload, but also keep their situation awareness sufficiently high so that they can recognize and intervene when automation fails? It remains to be seen whether the systems in development today will actually account for all of these socio-technical variables instead of just focusing on the technical ones.

The critical lesson to be learned from this meta-analysis is that the success of any UAS, and more generally multiple command and control task management, is not just contingent on high levels of autonomy, but more linked to robust system automation strategies that account for human operators' cognitive abilities, both positive and negative. Thus, it is critical that developers of multiple UAS



control stations today recognize and design for the complex interactions between highly automated systems and the need to support human knowledge-based reasoning.

## **Acknowledgments**

This research is partially funded by the Office of Naval Research. The views and conclusions presented in this paper are those of the authors and do not represent an official opinion, expressed or implied, of ONR.

## **References**

- 32nd Army Air and Missile Defense Command. 2003. Patriot missile defense operations during Operation Iraqi Freedom. Washington: U.S. Army.
- Alberts, D.S., and R.E. Hayes. 2006. *Understanding command and control*. Washington: Command and Control Research Program.
- Alberts, D.S., J.J. Garstka, and F.P. Stein. 1999. *Network centric warfare*. Washington: Command and Control Research Program.
- Boiney, L. 2005. Team decision making in time-sensitive environments. Paper presented at 10th ICCRTS in McLean, VA.
- Bolia, R.S., M.A. Vidulich, and W.T. Nelson. 2006. Unintended consequences of the network-centric decision making model: Considering the human operator. Paper presented at CCRTS in San Diego, CA.
- Broadbent, D.E. 1958. *Perception and communication*. Oxford: Pergamon.
- Caterinicchia, D. 2003. DoD chat use exploded in Iraq. *Federal Computer Week*.
- Crandall, J.W., and M.L. Cummings. In press. Identifying predictive metrics for supervisory control of multiple robots. *IEEE Transactions on Robotics: Special Issue on Human-Robot Interaction*.

- Cummings, M.L. 2004. Automation bias in intelligent time critical decision support systems. Paper presented at AIAA 3rd Intelligent Systems Conference in Chicago, IL.
- Cummings, M.L., A.S. Brzezinski, and J.D. Lee. 2007a. The impact of intelligent aiding for multiple unmanned aerial vehicle schedule management. *IEEE Intelligent Systems: Special Issue on Interacting with Autonomy* 22(2): 52–59.
- Cummings, M.L., and P.J. Mitchell. 2006. Automated scheduling decision support for supervisory control of multiple UAVs. *AIAA Journal of Aerospace Computing, Information, and Communication* 3(6): 294–308.
- Cummings, M.L., and P.J. Mitchell. In press. Predicting controller capacity in remote supervision of multiple unmanned vehicles. *IEEE Transactions on Systems, Man, and Cybernetics – Part A: Systems and Humans*.
- Cummings, M.L., and S. Guerlain. 2007. Developing operator capacity estimates for supervisory control of autonomous vehicles. *Human Factors* 49: 1–15.
- Cummings, M.L., C.E. Nehme, and J. Crandall. 2007b. Predicting operator capacity for supervisory control of multiple UAVs. In *Innovations in intelligent machines: Studies in computational intelligence* 70, ed. J.S. Chahl, L. C. Jain, A. Mizutani, and M. Sato-Ilic.
- Curts, R.J., and J.P. Frizzell. 2005. Implementing network-centric command and control. Paper presented at 10th ICCRTS in Washington, DC.
- Dixon, S., C.D. Wickens, and D. Chang. 2004. Unmanned aerial vehicle flight control: False alarms versus misses. Paper presented at Humans Factors and Ergonomics Society 48th Annual Meeting in New Orleans, LA.
- Dixon, S., C.D. Wickens, and D. Chang. 2005. Mission control of multiple unmanned aerial vehicles: A workload analysis. *Human Factors* 47: 479–487.

- Dunlap, R.D. 2006. The evolution of a distributed command and control architecture for semi-autonomous air vehicle operations. Paper presented at Moving Autonomy Forward Conference in Grantham, UK.
- Endsley, M.R. 1995. Toward a theory of situation awareness in dynamic systems. *Human Factors* 37: 32–64.
- Endsley, M.R., and D.B. Kaber. 1999. Level of automation effects on performance, situation awareness and workload in a dynamic control task. *Ergonomics* 42: 462–492.
- Endsley, M.R., and D.J. Garland. 2000. *Situation awareness analysis and measurement*. Mahwah: Lawrence Erlbaum Associates, Inc.
- Heacox, N.J. 2003. Survey of chat usage in the fleet results. San Diego: Pacific Science & Engineering Group.
- Hilburn, B., P.G. Jorna, E.A. Byrne, and R. Parasuraman. 1997. The effect of adaptive air traffic control (ATC) decision aiding on controller mental workload. In *Human-automation interaction: Research and practice*, ed. Mustapha Mouloua and Jefferson M. Koonce, 84–91. Mahwah: Lawrence Erlbaum.
- Joint Chiefs of Staff. 2007. Chairman of the Joint Chiefs of Staff instruction 6212.01D. DoD.
- Kilgore, R.M., K.A. Harper, C. Nehme, and M.L. Cummings. 2007. Mission planning and monitoring for heterogeneous unmanned vehicle teams: A human-centered perspective. Paper presented at AIAA Infotech@Aerospace Conference in Sonoma, CA.
- Lee, J.D., and N. Moray. 1992. Trust, control strategies and allocation of functions in human-machine systems. *Ergonomics* 35: 1234–1270.
- Lee, J.D., and N. Moray. 1994. Trust, self-confidence, and operators' adaptation to automation. *International Journal of Human-Computer Studies* 40: 153–184.

- Lewis, M., J. Polvichai, K. Sycara, and P. Scerri. 2006. Scaling-up human control for large UAV teams. In *Human factors of remotely operated vehicles*, ed. N. Cooke, H. Pringle, H. Pedersen, and O. Connor, 237–250. New York: Elsevier.
- Mosier, K.L., and L.J. Skitka. 1996. Human decision makers and automated decision aids: Made for each other? In *Automation and human performance: Theory and applications, human factors in transportation*, ed. R. Parasuraman and M. Mouloua, 201–220. Mahwah: Lawrence Erlbaum Associates, Inc.
- Naval Studies Board. 2005. Autonomous vehicles in support of naval operations. Washington: National Research Council.
- Office of the Secretary of Defense (OSD). 2005. Unmanned aircraft systems (UAS) roadmap, 2005–2030. Washington: DoD.
- Parasuraman, R. 1993. Effects of adaptive function allocation on human performance. In *Human factors and advanced aviation technologies*, ed. D.J. Garland and J.A. Wise, 147–157. Daytona Beach: Embry-Riddle Aeronautical University Press.
- Parasuraman, R., and V.A. Riley. 1997. Humans and automation: Use, misuse, disuse, and abuse. *Human Factors* 39: 230–253.
- Parasuraman, R., R.T. Molloy, and I.L. Singh. 1993. Performance consequences of automation-induced “complacency.” *International Journal of Aviation Psychology* 3.
- Parasuraman, R., T.B. Sheridan, and C.D. Wickens. 2000. A model for types and levels of human interaction with automation. *IEEE Transactions on Systems, Man, and Cybernetics – Part A: Systems and Humans* 30: 286–297.
- Rasmussen, J. 1983. Skills, rules, and knowledge: Signals, signs, and symbols, and other distractions in human performance models. *IEEE Transactions on Systems, Man, and Cybernetics* 13: 257–266.

- Riley, V. 1994. A theory of operator reliance of automation. In *Human performance in automated systems: Current research and trends*, ed. M. Mouloua and R. Parasuraman, 8–14. Hillsdale: Lawrence Erlbaum Associates.
- Ruff, H.A., G.L. Calhoun, M.H. Draper, J.V. Fontejon, and B.J. Guilfoos. 2004. Exploring automation issues in supervisory control of multiple UAVs. Paper presented at 2nd Human Performance, Situation Awareness, and Automation Conference (HPSAA II) in Daytona Beach, FL.
- Ruff, H.A., S. Narayanan, and M.H. Draper. 2002. Human interaction with levels of automation and decision-aid fidelity in the supervisory control of multiple simulated unmanned air vehicles. *Presence* 11: 335–351.
- Sheridan, T.B. 1992. *Telerobotics, automation and human supervisory control*. Cambridge: The MIT Press.
- Sheridan, T.B., and W.L. Verplank. 1978. Human and computer control of undersea teleoperators. In *Man-machine systems laboratory report*. Cambridge: MIT.
- Simon, H.A., R. Hogarth, C.R. Piott, H. Raiffa, K.A. Schelling, R. Thaler, A. Tversky, and S. Winter. 1986. Decision making and problem solving. Paper presented at Research Briefings 1986: Report of the Research Briefing Panel on Decision Making and Problem Solving in Washington, DC.
- Smith, P.J., E. McCoy, and C. Layton. 1997. Brittleness in the design of cooperative problem-solving systems: The effects on user performance. *IEEE Transactions on Systems, Man, and Cybernetics* 27: 360–370.
- Welford, A.T. 1952. The psychological refractory period and the timing of high-speed performance: A review and a theory. *British Journal of Psychology* 43: 2–19.
- Wickens, C.D., S.E. Gordon, and Y. Liu. 1998. *An introduction to human factors engineering*. New York: Longman.