



**NAVAL
POSTGRADUATE
SCHOOL**

MONTEREY, CALIFORNIA

THESIS

**THE MAKARA OF HIZBALLAH:
DECEPTION IN THE 2006 SUMMER WAR**

by

David A. Acosta

June 2007

Thesis Advisor:
Second Reader:

Hy Rothstein
Heather S. Gregg

Approved for public release; distribution is unlimited

THIS PAGE INTENTIONALLY LEFT BLANK

REPORT DOCUMENTATION PAGE			Form Approved OMB No. 0704-0188	
Public reporting burden for this collection of information is estimated to average 1 hour per response, including the time for reviewing instruction, searching existing data sources, gathering and maintaining the data needed, and completing and reviewing the collection of information. Send comments regarding this burden estimate or any other aspect of this collection of information, including suggestions for reducing this burden, to Washington headquarters Services, Directorate for Information Operations and Reports, 1215 Jefferson Davis Highway, Suite 1204, Arlington, VA 22202-4302, and to the Office of Management and Budget, Paperwork Reduction Project (0704-0188) Washington DC 20503.				
1. AGENCY USE ONLY (Leave blank)		2. REPORT DATE June 2007	3. REPORT TYPE AND DATES COVERED Master's Thesis	
4. TITLE AND SUBTITLE The Makara of Hizballah: Deception in the 2006 Summer War			5. FUNDING NUMBERS	
6. AUTHOR(S) David A. Acosta				
7. PERFORMING ORGANIZATION NAME(S) AND ADDRESS(ES) Naval Postgraduate School Monterey, CA 93943-5000			8. PERFORMING ORGANIZATION REPORT NUMBER	
9. SPONSORING /MONITORING AGENCY NAME(S) AND ADDRESS(ES) N/A			10. SPONSORING/MONITORING AGENCY REPORT NUMBER	
11. SUPPLEMENTARY NOTES The views expressed in this thesis are those of the author and do not reflect the official policy or position of the Department of Defense or the U.S. Government.				
12a. DISTRIBUTION / AVAILABILITY STATEMENT Approved for public release; distribution is unlimited			12b. DISTRIBUTION CODE	
13. ABSTRACT (maximum 200 words) Information, while always a critical element of warfare, is quickly becoming decisive in present day conflicts. While the use of this information can take many forms, one area where the discussion of information's impact on conflict has been delinquent is in the art of deception. Hizballah and Israel serve as the perfect backdrop to examine the effects of deception in current conflicts. While Israel has always maintained a hard power advantage through its military might and prowess, Hizballah looked for other ways to level the playing field. The use of information in supporting deception, which has been a key enabler for the weaker side, became one of the answers to redressing the military balance. This paper will demonstrate that Hizballah, fighting an asymmetric conflict with Israel, used deception very effectively in their defense of southern Lebanon during the 2006 Summer War; this use of deception significantly offset many of Israel's hard power advantages. It will also show that Hizballah's use of information technologies greatly enhanced their ability to wield deception. Finally, this paper will address the interrelation of various information activities and the need to maintain consolidation of these activities for planning and execution on the modern battlefield.				
14. SUBJECT TERMS Terrorism, Hizballah, Information Operations, Deception, Israel, 2006 Summer War			15. NUMBER OF PAGES 93	
			16. PRICE CODE	
17. SECURITY CLASSIFICATION OF REPORT Unclassified	18. SECURITY CLASSIFICATION OF THIS PAGE Unclassified	19. SECURITY CLASSIFICATION OF ABSTRACT Unclassified	20. LIMITATION OF ABSTRACT UL	

THIS PAGE INTENTIONALLY LEFT BLANK

Approved for public release; distribution is unlimited

**THE MAKARA OF HIZBALLAH:
DECEPTION IN THE 2006 SUMMER WAR**

David A. Acosta
Captain, United States Army
B.S., United States Air Force Academy, 1998

Submitted in partial fulfillment of the
requirements for the degree of

MASTER OF SCIENCE IN INFORMATION OPERATIONS

from the

**NAVAL POSTGRADUATE SCHOOL
June 2007**

Author: David A. Acosta

Approved by: Hy Rothstein
Thesis Advisor

Heather S. Gregg
Second Reader

Gordon McCormick
Chairman, Department of Defense Analysis

THIS PAGE INTENTIONALLY LEFT BLANK

ABSTRACT

Information, while always a critical element of warfare, is quickly becoming decisive in present day conflicts. While the use of this information can take many forms, one area where the discussion of information's impact on conflict has been delinquent is in the art of deception.

Hizballah and Israel serve as the perfect backdrop to examine the effects of deception in current conflicts. While Israel has always maintained a hard power advantage through its military might and prowess, Hizballah looked for other ways to level the playing field. The use of information in supporting deception, which has been a key enabler for the weaker side, became one of the answers to redressing the military balance.

This paper will demonstrate that Hizballah, fighting an asymmetric conflict with Israel, used deception very effectively in their defense of southern Lebanon during the 2006 Summer War; this use of deception significantly offset many of Israel's hard power advantages. It will also show that Hizballah's use of information technologies greatly enhanced their ability to wield deception. Finally, this paper will address the interrelation of various information activities and the need to maintain consolidation of these activities for planning and execution on the modern battlefield.

THIS PAGE INTENTIONALLY LEFT BLANK

TABLE OF CONTENTS

I.	INTRODUCTION.....	1
II.	DECEPTION DEFINED.....	5
	A. INTRODUCTION.....	5
	B. DECEPTION EXPLORED.....	6
	C. GENERAL FRAMEWORK.....	8
	D. THE MECHANICS OF DECEPTION.....	10
	E. RELATED ACTIVITIES.....	14
	F. METHODOLOGY.....	16
	G. CONCLUSION.....	17
III.	HISTORY AND ORGANIZATION OF HIZBALLAH.....	19
	A. INTRODUCTION.....	19
	B. LEBANON: MODERN HISTORY.....	20
	C. THE CREATION AND RISE OF HIZBALLAH.....	21
	1. The Early Years.....	22
	2. The “Lebanonization Process”.....	23
	3. Hizballah Today.....	25
	D. HIZBALLAH’S ORGANIZATION.....	26
	1. Overview.....	26
	2. Chain of Command.....	27
	3. Support Organizations.....	29
	a. <i>Combat Organ</i>	29
	b. <i>Enforcement, Recruitment and Propaganda Organ</i>	29
	c. <i>Holy Reconstruction Organ</i>	30
	d. <i>Security Organ</i>	30
	E. CONCLUSION.....	31
IV.	DECEPTION IN THE 2006 SUMMER CONFLICT.....	33
	A. INTRODUCTION.....	33
	B. BACKGROUND.....	35
	C. HIZBALLAH’S DENIAL OPERATIONS.....	40
	D. THE BUNKERS.....	43
	E. ELECTRONIC WARFARE BLUFF.....	45
	F. MEDIA & THE BATTLE OF THE STORY.....	50
	G. HIJACKING THE INTERNET.....	58
	H. CONCLUSION.....	61
V.	CONCLUSION.....	63
	A. RE-EXAMINING DECEPTION IN THE INFORMATION AGE.....	63
	B. LINKAGES BETWEEN INFORMATION OPERATION CAPABILITIES.....	66
	C. AREAS FOR FURTHER RESEARCH.....	66

1.	Application of These Deception Criteria to Other information Age Conflicts	66
2.	Examination of the Relationship Between Psychological Operations and Deception	67
3.	Deception in Computer Network Operations	67
4.	The Role of Non-Combatants in Information Age Conflicts	67
D.	CONCLUSION	68
	LIST OF REFERENCES.....	71
	INITIAL DISTRIBUTION LIST	77

LIST OF FIGURES

Figure 1.	Deception Information Flow to Target.....	11
Figure 2.	The Deception Puzzle	12
Figure 3.	Possibilities during the transmitting and interpreting of a signal	13
Figure 4.	Hizballah Organizational Structure	27
Figure 5.	Original Reuters Picture	55
Figure 6.	Adnan Hajj's Doctored Photograph	55
Figure 7.	Deception Information Flow to Target.....	64
Figure 8.	New Model for Deception Information Flow Hierarchy.....	65

THIS PAGE INTENTIONALLY LEFT BLANK

LIST OF TABLES

Table 1.	Deception Criteria Evaluation Table	17
Table 2.	Deception Evaluation example	34
Table 3.	Deception Operations Carried Out by Hizballah	35
Table 4.	Evaluation of Bunker Deception	45
Table 5.	Evaluation of EW Bluff.....	49
Table 6.	The Media Deception	58
Table 7.	Hijacking the Internet.....	61
Table 8.	Summary of Deception Activities.....	63

THIS PAGE INTENTIONALLY LEFT BLANK

ACKNOWLEDGMENTS

I would like to thank all the people whom I have met over the years who helped to further my interests in Information Operations. Among I would like to mention are: MG (R) Kenneth Quinlan, USA; COL (P) Robert Carr, USA; COL Joel Mjolsness, USA; COL David Lee, USA; LTC Mike Dominique, USA; LTC (R) Boyd Brown, USA; Mr. Tim Thomas, and Les Grau, FMSO; and all of the faculty and staff of the Defense Analysis Department at NPS. I would also like to thank Mr. Andrew Exum of the Washington Institute for Near East Policy for his time in painting a picture of southern Lebanon in the aftermath of the conflict.

I would also like to thank my fellow classmates here at NPS who made this experience truly remarkable and unforgettable. In particular I would like to thank MAJ Jason Colbert, USA for keeping me focused, but humored during all the long hours studying together. I would also like to thank my advisor and second reader, Dr. Hy Rothstein, COL (R), USA and Dr. Heather S. Gregg, for their academic guidance, support, mentorship, and the benefit of their experience.

Finally, I would like to thank my family for their continued support over the years and the many adventures we have had. I would also like to thank Erin O'Marr for her support and prayers for every thesis idea I had, no matter how ridiculous it seemed.

THIS PAGE INTENTIONALLY LEFT BLANK

I. INTRODUCTION

makara (Arabic): *n.* deception.¹

There's a war out there, old friend. A world war. And it's not about who's got the most bullets. It's about who controls the information. What we see and hear, how we work, what we think... it's all about the information! ²

- Ben Kingsley as "Cosmo"
Sneakers, 1992

Information, while always a critical element of warfare, is quickly becoming decisive in the conflicts of the present day. The rapid propagation of information technology across the world has dramatically altered human interaction and the conduct of communications from the local to the global level. In a recent article entitled "Mind Maneuvers" published in *Armed Forces Journal*, author Frank Hoffman describes it this way:

The informational component of war is increasing in impact. Modern 24/7 news cycles and graphic imagery, combined with the worldwide networks, produce even faster and higher response cycles from audiences around the globe and offer powerful new tools. Advanced methods and ever lower costs allow many insurgent or terrorist groups to communicate directly to their target audiences.³

Being able to get your story out quicker and having it be more believable than your opponent's increases one side's chances to influence their targeted audiences, whether they are the enemy, his population, or one's own populace. While the use of this information can take many forms such as public affairs, or

¹ N. S. Doniach, ed. *The Oxford English-Arabic Dictionary*, (Oxford, England: Clarendon Press, 1972), 310.

² Phil Robinson and Lawrence Lasker et al., *Sneakers* [Motion picture]. (Hollywood, CA: Universal. 1992).

³ Frank G. Hoffman, "Mind Maneuvers," *Armed Forces Journal*, April 2007, <http://www.armedforcesjournal.com/2007/04/2550166/>, (accessed 24 April 2007).

psychological operations, one area where the discussion of information's impact on conflict has been delinquent is in the art of deception.

Hizballah and Israel serve as the perfect backdrop to examine the effects of deception in current asymmetric conflicts. While Israel has always maintained a hard power advantage through its military might and prowess, Hizballah looked for other ways to level the playing field. The use of information in supporting deception, which has been a key enabler for the weaker side, became one of the answers to redressing the military balance. Marvin Kalb of the Shorenstein Center at Harvard University iterates this very point in a recent paper on the 2006 Summer War that "In the war of information, news and propaganda, the battlefield central to Hezbollah's strategy, Israel lost this war."⁴ Much of this was because Hezbollah's execution of deception.

Over the 33 days of the conflict, while Israel had the moral high ground for action and dominated Hizballah militarily, it was Hizballah's message that permeated many Lebanese and Arab audiences in the region, to give Hizballah the appearance of victory nonetheless. From tactical events like fake bunkers along the Blue Line to operational events such as Hizballah's media tours of Beirut and Qana or the alleged hacking of Israeli secure radios, Hizballah's deceptive acts helped to control the strategic narrative Israel and the rest of the world saw. Hizballah's use of deception in the recent asymmetric conflict with Israel shows how effective deception can be in the information age.

This paper will demonstrate that Hizballah, fighting an asymmetric conflict with Israel, used deception effectively in their defense of southern Lebanon during the 2006 Summer War; this use of deception significantly offset many of

⁴ Marvin Kalb, "The Israeli-Hezbollah War of 2006: The Media As A Weapon in Asymmetrical Conflict" *Joan Shorenstein Center on the Press, Politics and Public Policy*, February 2007, http://www.ksg.harvard.edu/presspol/research_publications/papers/research_papers/R29.pdf (accessed 24 April 2007).

Israel's hard power advantages. It will also show that Hizballah's use of information technologies greatly enhanced their ability to wield deception. Finally, this paper will address the interrelation of various information activities and the need to maintain consolidation of these activities for planning and execution on the modern battlefield.

THIS PAGE INTENTIONALLY LEFT BLANK

II. DECEPTION DEFINED

Warfare is the art of deceit. Therefore, when able, seem to be unable; when ready, seem unready; when nearby, seem far away; and when far away seem near. If the enemy seeks some advantage, entice him with it. If he is in disorder, attack him and take him. If he is formidable, prepare against him. If he is strong, evade him. If he is incensed, provoke him. If he is humble, encourage his arrogance. If he is rested, wear him down. If he is internally harmonious, sow divisiveness in his ranks. Attack where he is not prepared; go by way of places where it would never occur to him you would go.⁵

- Sun Tzu
The Art of War

A. INTRODUCTION

In order to fully understand deception and how to employ it effectively, it is first necessary to define the concept and understand its characteristics. The purpose of this chapter will be to examine the definition of deception and explore exactly what constitutes a deception operation. This will be accomplished by reviewing existing literature on the characteristics and types of deception used in conflicts. To further examine deception, this chapter will look at exactly how a deception operation works in terms of the perceptions, sensors and centers of gravity that must be targeted to accomplish the task. Finally, this chapter will look at complimentary information activities which support deception: denial or operational security, electronic warfare (EW), psychological operations (PSYOP), computer network operations (CNO). By looking at all these concepts and seeing how deception works it will be possible to establish criteria from which to evaluate how Hizballah used deception in their operations in the summer of 2006 and the degree of effectiveness.

⁵ Caleb Carr, ed., *The Book of War*, (New York: Modern Library Books, 2000), 65.

B. DECEPTION EXPLORED

Simply put deception is the deliberate misrepresentation of reality done to gain a competitive advantage.⁶ It has been used throughout history for one side or another to gain an advantage over their opponent. In many cases its use by the weaker side compensates for numerical deficiencies such as soldiers, equipment and even economic resources; for that reason the weaker side often has a more powerful incentive to resort to the use deception in their operations.⁷ As effective a tool as it might be, there are still many biases to its use in modern armies such as the United States.

Unlike many other concepts in warfare, deception is not a science, but much more like an art form. As Michael Handel describes “deception is a creative art and not an exact science or even a craft.”⁸ He goes on to add that “this explains why, despite the large number of war memoirs and detailed military histories which discuss deception, little has been written on the theory of deception or how to practice it.”⁹ For this reason it is often ignored today. Despite fears associated with deception, it should be obvious that “deception planning can be quite involved and complex; its execution can be quite risky, *but its benefits can be overwhelming.*”¹⁰

For many the idea of deception in warfare conjures up images of cloak and dagger activities, such as inflatable tanks and aircraft used in Operations FORTITUDE, the deception plan for the Allied invasion of Normandy or the infamous dead body of Operation MINCEMEAT, the deception for the Allied

⁶ Donald C. Daniel and Katherine Herbig, “Propositions of Military Deception,” in *Strategic Military Deception*, ed. Donald C. Daniel and Katherine L. Herbig, (New York: Pergamon Press, 1982), 3.

⁷ Michael Handel, “Intelligence and Deception,” in *Military Deception and Strategic Surprise*, ed. John Gooch and Amos Perlmutter, (London: Frank Cass & Co. Ltd, 1982), 123-4.

⁸ Handel, 136.

⁹ *Ibid.*, 136.

¹⁰ Charles Fowler and Robert Nesbit, “Tactical Deception in Air-Land Warfare,” *Journal of Electronic Defense*, June 95, 42.

invasion of Sicily. For most Americans just the idea of deception, in the words of Walter Jajko, a career intelligence officer, is seen as “intimidating, unacceptable, and even evil...sinister and, therefore, suspect.”¹¹ James Dunnigan and Albert Nofi in their piece “Deception Explained, Described, and Revealed,” make a similar point to Jajko’s in that “deception is at once one of the most powerful weapons a soldier has access to, and the one most frequently avoided because of the risk.”¹² Yet this should not be the case. Dunnigan and Nofi go on to add that deception “is too useful a tool to abandon simply because the troops might not be up to it.”¹³ Deception has always been an aspect of war, even being mentioned in the Old Testament of the Bible and the Koran as a mean of overcoming adversaries.¹⁴

While modern armies may have prejudices against the use of deception, the advent of the information age and information warfare does not change the prospects for its use in modern conflicts; in fact the opposite is quite true. As retired U.S. Army Colonel Steve Fondacaro professes

The new element of power that has emerged in the last thirty to forty years and has subsumed the rest is information. A revolution happened without us knowing or paying attention. Perception truly now is reality, and our enemies know it. We have to fight on the information battlefield.¹⁵

Jajko continues this thought with regards to deception that “The advent of information warfare offers unprecedented opportunities for deception operations

¹¹ Walter Jajko, “Deception: Appeal for Acceptance; Discourse on Doctrine; Preface to Planning,” *Comparative Strategy*, 21: 351-363, 2002.

¹² James Dunnigan and Albert Nofi, “Deception Explained, Described, and Revealed,” *Victory and Deceit: Dirty Tricks in War* (New York: W. Morrow, 1995), 2.

¹³ *Ibid.*, 5.

¹⁴ See Abdullah Yusuf Ali, *The Meaning of the Holy Qur’an*, (Baltimore MD: Amana Publications, 1989), 141 and the story of Gideon in Judges 7, New International Version Bible.

¹⁵ George Packer, “Knowing the Enemy,” *New Yorker*, 18 December 2006. <http://proquest.umi.com.libproxy.nps.navy.mil> (accessed 7 June 2007).

in scope, effect, and imagination.”¹⁶ Thus the study of deception and the ways to employ it into conflicts of the information age must continue to be studied and evaluated.

C. GENERAL FRAMEWORK

Deception, while easy to define, has many unique characteristics and can be quite difficult to grasp. As discussed earlier just the thought of injecting deception into an operation can cause a stir because of its connotations. As previously mentioned, deception is “the deliberate misrepresentation of reality done to gain a competitive advantage,” in the words of Donald Daniel and Katherine Herbig.¹⁷ In order to gain this advantage, Herbig and Daniel list three goals that a deception operation must have: to condition the target’s beliefs; to influence the target’s actions; and ultimately for the deceiver to benefit from the target’s actions.¹⁸ There are many ways to accomplish these goals. James Dunnigan and Albert Nofi in their piece entitled “Deception Explained, Described, and Revealed” list nine techniques which may be employed in deception. These include: concealment, camouflage, false and planted information, ruses, displays, demonstrations, feints, lies, and insight.¹⁹ While no deception operation need use of all these techniques, they serve as an important guideline for the employment and evaluation of deception later on.

In addition to these characteristics of deception another point that Herbig and Daniel bring up deals with types of deception. In their writings, these authors describe two types of deception: ambiguity increasing, and misleading types. The first, ambiguity increasing or A-type, “confuses a target so that the target is unsure as to what to believe.”²⁰ They go on to discuss that “in order to have an

¹⁶ Jajko, 362.

¹⁷ Daniel and Herbig, 3.

¹⁸ Ibid., 5.

¹⁹ Dunnigan and Nofi, 22.

²⁰ Daniel and Herbig, 5.

impact, A-type deceptions require that the deceiver's lies be plausible enough and consequential enough to the target's well being that the target cannot ignore them."²¹ In essence this means that the deception operation aims to confuse the target so that they are unsure as to what an exact course of action will be or how to react to it. In history this is often associated with Operation BODYGUARD, in which the Allies created the allusion of an amphibious invasion somewhere in Europe, ranging from Scandinavia to the south of France. Because there existed a sense of ambiguity as to where an invasion would occur, the Germans were forced to keep combat forces arrayed across the theater, preventing them from reinforcing the French coast, where the real invasion occurred.

The second type of deception, the misleading or M-type, seeks to "reduce ambiguity by building up the attractiveness of one wrong alternative."²² This type of deception operation has the target putting all of his eggs in one basket (i.e. the wrong alternative), thus allowing the deceiver a much great chance for success in greater operation. As the Allies in World War II learned through intelligence sources that the Germans believed that the actual invasion of Europe would come at the Pas de Calais shortly before the real Normandy invasion, Allied deception planners created Operation FORTITUDE SOUTH, a M-type deception designed to reinforce this wrong alternative's attractiveness. Abandoning the A-type deception of invasion somewhere across Fortress Europe sought in BODYGUARD, FORTITUDE SOUTH particularly "sought to portray the Normandy landings as preliminary to a much larger invasion at Pas de Calais."²³ This deception operation as Dunnigan and Nofi point out kept German Army units positioned near the Pas de Calais for a remarkable six weeks after D-Day "preparing to repel an invasion that was never intended."²⁴

²¹ Daniel and Herbig, 5.

²² Ibid., 10.

²³ Ibid., 6.

²⁴ Ibid., 7.

D. THE MECHANICS OF DECEPTION

Having looked at factors involved in employment of deception, the next task to examine is how and why deception works. Richards Heuer, an author on the psychological aspects of deception provides much insight on the cognitive aspects of why deception works. Key to his work, Heuer looks at perceptions. Heuer makes the comment that “we tend to perceive what we expect to perceive” and that “it takes more information, and more unambiguous information, to recognize an unexpected phenomenon than an expected one.”²⁵ He goes on to say that one of the most important characteristics of perceptions is that “they are quick to form but resistant to change.”²⁶ An opponent will base much of how he plans and fights on how he perceives the other side’s actions. Being able to manipulate this thinking process of what is seen and how it is perceived is key to launching a deception operation. Giving an enemy a picture of what he expects is or what he has been led to expect is the goal of deception. Heuer summarizes this when he writes “it is far easier to lead a target astray by reinforcing the target’s existing beliefs, thus causing the target to ignore the contrary evidence of one’s true intent, than it is to persuade a target to change his or her mind.”²⁷

In order to affect the enemy’s perception, a successful deception strategy needs to capitalize on a hierarchy of information flow. This hierarchy consists of three levels: the enemy commander, his intelligence agencies, and finally the sensors which collect information. A model for this structure can be found in Figure 1.

²⁵ Richards J. Heuer, “Cognitive Factors in Deception and Counterdeception,” in *Strategic Military Deception*, ed. Donald C. Daniel and Katherine L. Herbig, (New York: Pergamon Press, 1982), 34.

²⁶ *Ibid.*, 36.

²⁷ *Ibid.*, 42.

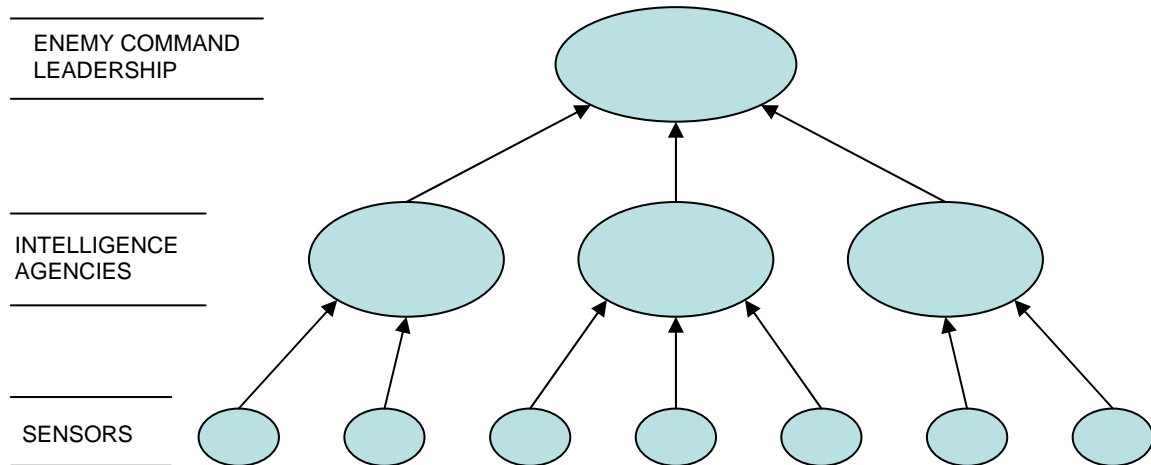

Figure 1. Deception Information Flow to Target

Central to making any deception strategy succeed is a plan which targets the enemy leadership. In the words of Thaddeus Holt in the book *The Deceivers*, “Deception is aimed at the enemy commander, by way of his intelligence people.”²⁸ He goes on to add that “To gauge the enemy commander’s reaction you must know him; know how his mind works, know what makes him tick, know what kind of stimulus will evoke what kind of response.”²⁹ Jajko also emphasizes this as he writes “The target of any deception is the adversarial decisionmaker,” and that “deception activities are intended to affect an adversarial leadership’s behavior—always behavior...”³⁰ With that in mind, the next step of the deception information flow lies with the adversarial intelligence agencies. Holt argues “The enemy commander is the deceiver’s target, but he is not the deceiver’s customer. The customer is the enemy intelligence service, who gather and process information and present it to the commander.”³¹ These intelligence services or agency operatives in the words of Herbig and Daniel, “seek out and collect

²⁸ Thaddeus Holt, *The Deceivers*, (New York: Scribner, 2004), 56.

²⁹ *Ibid.*, 56.

³⁰ Jajko, 354.

³¹ Holt, 59.

information and analysts who coordinate and evaluate it.”³² Yet even below the intelligence collectors and analysts, at the basic level lies the sensors from which they collect. Sensors are any form of information gathering asset to include, but not limited to: spies, radio, television, signals intelligence (SIGINT), imagery, and in today’s information age, the internet, cell phones, etc. How one side is able to engage and influence an opponent’s sensors will greatly influence how effective a deception plan will be. Both being able to paint a believable picture for an adversary’s sensors of the pieces of one’s deception puzzle and then being able to send enough signals to those sensors so that they are picked up, analyzed and the intended actions realized by one’s foe are key to making deception work. Figures 2 and 3 illustrate these points.

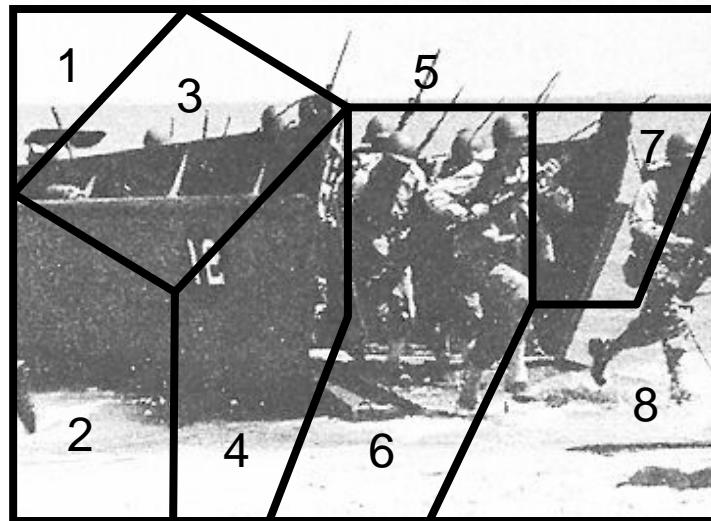

Figure 2. The Deception Puzzle³³

³² Daniel and Herbig, 8.

³³ Ibid., 11.

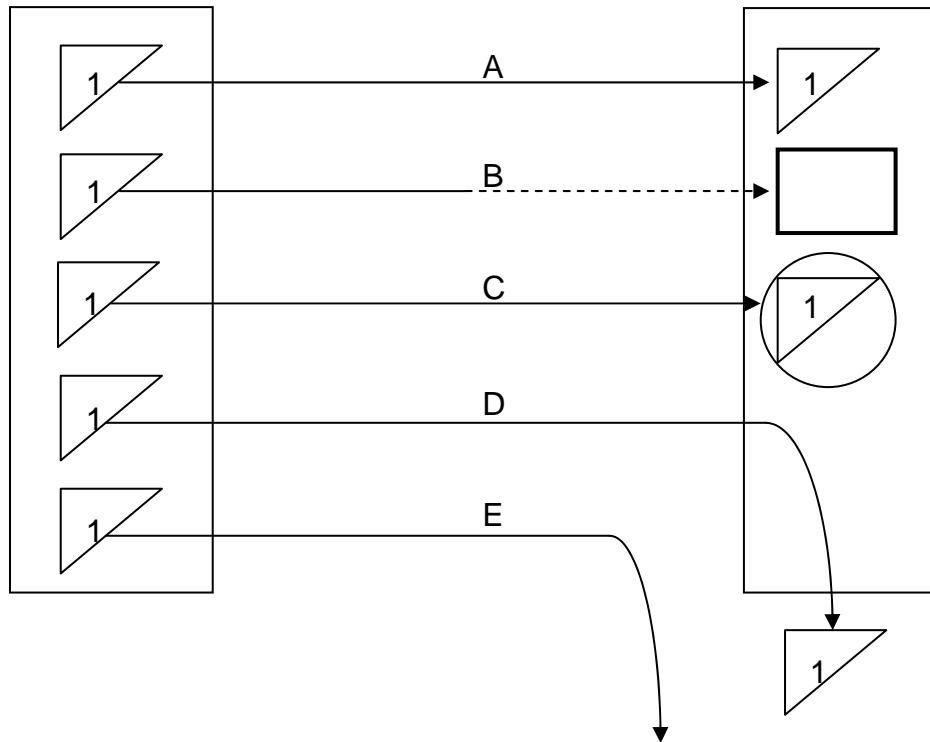

Figure 3. Possibilities during the transmitting and interpreting of a signal³⁴

Given Figure 2-2 represents the deception picture and its pieces that one side wants to project to an adversary, Daniel and Herbig determined that there are the five possible outcomes represented by Figure 2-3 for each signal or piece.³⁵ The first outcome, A, represents “the deceivers fondest hope” that the adversary would receive the message and act accordingly. Outcome B, on the other hand, represents a signal that is garbled or fails to be recognized by the enemy’s sensors. The next two outcomes, C and D, represent signals that while might have reached the enemy’s intelligence service, are either misinterpreted (outcome C), or disregarded after initial receipt (outcome D). Finally, the last outcome E, portrays a signal that fails altogether to make it to the enemy’s sensors for one reason or another. In summary then a deception operation will

³⁴ Daniel and Herbig, 11.

³⁵ Ibid., 12.

work best when one is able to fool their opponent by manipulating their opponent's sensors into seeing a picture that is contrary to what one's true intentions are.

Finally, when considering deception in the information age, Robert Nesbit and Charles Fowler in the *Journal of Electronic Defense*, iterate the relationship between advanced sensor technology and deception in that "It is quite possible...overall vulnerability to deception could increase as one's sensors become more sophisticated."³⁶ This hypothesis holds true for the summer conflict in 2006. Having looked at how deception works, the next task is to look at those activities which closely relate to it.

E. RELATED ACTIVITIES

The final area with which to examine deception involves its relationship to other types of information operation capabilities. According to U.S. doctrine, capabilities linked to deception include: operational security (OPSEC), computer network operations (CNO), psychological operations (PSYOP), public affairs (PA), and electronic warfare (EW).³⁷ While all of these activities are considered information activities, those most applicable to this discussion are OPSEC, and PSYOP.

Perhaps the greatest complementary activity to deception is that of OPSEC or, as it is more commonly known, denial. This term refers to "the attempt to block all information channels by which an adversary could learn some truth (e.g. about a military development program, a policy, course of action, etc.),

³⁶ Fowler and Nesbit, 77.

³⁷ As described in Joint Publication (JP) 3-13, *Information Operations*, the linkages are very clear and thus can be applied to any military force to include terrorist and insurgent networks. For further information on the inter-relationships between information operations capabilities, supporting and related capabilities see: U.S. Department of Defense, *Joint Publication 3-13: Information Operations*, (Washington D.C.: Government Printing Office, 13 February 2006), Appendix B.

thus preventing him from reacting in a timely manner.”³⁸ Essentially, this is the same thing as OPSEC.³⁹ The JP 3-13 describes the relationship between OPSEC and deception as that “while MILDEC seeks to encourage incorrect analysis, causing the adversary to arrive at specific false deductions, OPSEC seeks to deny real information to an adversary and prevent correct deduction of friendly plans.”⁴⁰ Abram Shulsky, in the book *Strategic Denial and Deception*, notes:

Almost by definition, deception must include denial: in order to induce an adversary to accept a cover story, information that would reveal the true state of affairs must be denied him. Conversely, a...denial effort may well include some element of deception. In order to deny the adversary knowledge of the truth, it may be advisable to develop and provide him with a “cover story” to help explain any information about the actual state of affairs that might get through to him.⁴¹

The use of PSYOP or psychological warfare is another information activity where parallels can be drawn to deception. The US defines PSYOP as “planned operations to convey selected truthful information and indicators to foreign audiences to influence their emotions, motives, objective reasoning, and ultimately, the behavior of their governments, organizations, groups and individuals.” Furthermore, the US regards PSYOP’s purpose as “to induce or reinforce foreign attitudes and behavior favorable to the originator’s objectives.” Another author, Ron Schliefer, in his article detailing Hezbollah’s psychological operations prior to Israel’s withdrawal in 2000, claims that PSYOP “consists of

³⁸ Abram Shulsky, “Elements of Strategic Denial and Deception,” ed. Roy Godson and James J. Wirtz, in *Strategic Denial and Deception*, (New Brunswick, NJ: Transaction Publishers, 2006), 15.

³⁹ JP 3-13, Information Operations defines OPSEC as the process of identifying critical information and subsequently analyzing friendly actions and other activities to: identify what friendly information is necessary for the adversary to have sufficiently accurate knowledge of friendly forces and intentions; *deny adversary decision makers critical information about friendly forces and intentions*; and cause adversary decision makers to misjudge the relevance of known critical friendly information because other information about friendly forces and intentions remains secure. JP 3-13, II-4.

⁴⁰ *Ibid.*, II-2.

⁴¹ Shulsky, 16.

delivering messages by nonviolent methods, to target audiences, domestic and neutral as well as among the enemy, with the aim of furthering the war effort.”⁴² While Thaddeus Holt echoes that in deception “Your goal is not to make the enemy think something; it is to make him do something,” there is substantial overlap between these two areas.⁴³ Both PSYOP and deception must affect one’s cognitive thought processes in order to achieve effects and both seek to have an adversary take action in one way or another. Perhaps the best way to think these two information activities is that basically PSYOP deals in the truth and deception in lies.

F. METHODOLOGY

Having explored the definition, characteristics, objectives and types of deception, it is now possible to establish criteria from which to evaluate deception operations and their effectiveness. Based on the information provided by Herbig and Daniel, a successful deception operation must meet the following criteria: 1) condition the target’s beliefs; 2) influence the target’s actions; and 3) the target’s actions must benefit the deceiver.

In addition to these criteria a deception operation should fall into one of the categories of either ambiguity increasing or misleading types. It must also show those sensors which picked up the deceptive information as well. Finally, a deception must fall into one of the nine techniques listed by Dunnigan and Nofi as closely as possible. In order to better visualize these criteria the following table will be used to evaluate the four cases of deception from the summer of 2006 conflict:

⁴² Ron Schleifer, “Psychological Operations: A New Variation of an Age Old Art: Hezbollah versus Israel,” *Studies in Conflict and Terrorism* 29 (2006): 2.

⁴³ Holt, 54.

CRITERIA	EVALUATION
Three Objectives? - condition the target's beliefs - influence the target's actions - target's actions must benefit the deceiver	
Sensors targeted?	
Type: M-type or A-type?	
9 Characteristics? (concealment, camouflage, false and planted information, ruses, displays, demonstrations, feints, lies, and insight)	

Table 1. Deception Criteria Evaluation Table

With these criteria established it will be possible to study Hizballah's deception operations from the 2006 Summer War and determine their effectiveness.

G. CONCLUSION

The art of deception is just that: a rare gem in the rough of many other forms of military science. While often misunderstood and under utilized, if used properly, the returns on the small amount invested can be enormous. As Michael Handel summarizes "Deception is cheap. It is neither labor- nor capital-intensive. It is among the least expensive types of modern intelligence work yet yields a high return for a relatively small investment."⁴⁴ In order to effectively launch a deception operation signals must follow the hierarchy from sensor to intelligence service to the real target, the enemy leader. In addition to following this model, key to this are those related activities like denial and OPSEC which bring as much weight to an operation as the deception itself. Finally, based on this information it is possible to construct guidelines for what constitutes a deception and how effective this deception really is. Having thoroughly looked at

deception, the focus now will be to examine Hizballah and how their development and capabilities have propelled them to be one of the world's most skilled users of deception today.

⁴⁴ Handel, 143.

III. HISTORY AND ORGANIZATION OF HIZBALLAH

Free downtrodden men,
We are the sons of Hizb Allah's nation in Lebanon. We greet you and address the entire world through you: notables, institutions, parties, organizations and political, humanitarian, and information associations. We exclude nobody because we are eager for all to hear our voice, understand our word, comprehend our projections, and study our plan.⁴⁵

A. INTRODUCTION

With these words a little known terrorist group announced to the world its intentions and dynamics. Born out of the chaos of the Lebanese civil war, Hizballah, the Party of God, quickly made a name for itself not only as a terrorist group, but in time as a complex organization reaching out across sectarian lines throughout the country. But what exactly is Hizballah? The answer to that question is the key to understanding the dynamics of this diverse organization. To the United States and Israel, it is viewed as a terrorist organization, an asymmetrical army of the regimes in Iran and Syria. To the Shi'a of Lebanon, it is seen as a social welfare organization. To many Lebanese it is seen as a political party and the primary resistance group to Israeli aggression. In essence it is all these things and more—Hizballah over the course of the last twenty five years has evolved from a rag-tag militia in Lebanon's Biqaa Valley to a diverse organization with global reach.

This chapter will examine Hizballah's history and organization and how these factors contributed to the group's effective use of deception in their conflict with Israel. It will look at how the recent history of Lebanon to include the Civil War and its aftermath helped shape Hizballah. It will also look at how Hizballah has transformed in recent years to meet new challenges in Lebanon. Finally, this paper will investigate the current organization of the group and why this structure

⁴⁵ Taken from Open Letter Addressed by Hizb Allah to the Downtrodden in Lebanon and in the World, translated in: Augustus Richard Norton, *Amal and the Shi'a: Struggle for the Soul of Lebanon*, (Austin TX: University of Texas Press, 1987), 168.

has enabled it to be a worthy adversary on today's information battlefield. Only by examining the history and organization of this robust institution can one take a full appreciation of its capabilities.

B. LEBANON: MODERN HISTORY

Lebanon was built on a delicate balance of power originating from its unique form of government known as the confessional system. Upsetting that balance on any leg would have terrible consequences for the country. The premise of the confessional system developed between the 1920s and 1940s is there exists a relative balance of power between the three major sects inside Lebanon: the President would be Maronite Christian, the Prime Minister a Sunni Muslim and the Speaker of the Lebanese Parliament a Shi'a Muslim. This system came about initially from the establishment of the Lebanese constitution in 1926, but as Helena Cobban notes "the 1926 constitution also stated that it should be applied only 'temporarily', until a fully non-sectarian system could develop in the country."⁴⁶ As the years went on, the internal politics of Lebanon and the burden of the Arab-Israeli conflict combined to place a heavy strain on the delicate confessional system, finally culminating in civil war in 1975.

Lebanon's system cracked from the pressures put upon from the Arab-Israeli conflict. Many in the Arab world, shocked by the rapid defeat of their forces, soon realized that "Guerrilla action...could 'redeem the honour of the Arabs', which the regular armies had so disgracefully lost".⁴⁷ In the years that followed the 1967 War and later the Black September events in Jordan in 1970, many Palestinian refugees settled in Lebanon. As refugee camps stood up and calls went out to join new Palestinian militias to fight the Israelis, many Lebanese found themselves having to choose not between sectarian divides, but rather whether or not they were "Arab."⁴⁸ In time these Palestinian militias started

⁴⁶ Cobban, 62.

⁴⁷ Cobban, 102.

⁴⁸ Cobban, 103.

cross-border raids against the Israelis, and the Israelis in turn attacked back into Lebanon. The strain of the Palestinians took its toll on the Lebanese government, as many in Maronite and Shi'a sects found themselves deeply at odds with their Sunni brethren over the issue of supporting the Palestinians. Thus by 1975 these divisions brought Lebanon into civil war. This civil war brought with it foreign intervention by way of Syria, Israel and later on Iran.

C. THE CREATION AND RISE OF HIZBALLAH

The story of Hizballah begins in 1982 following the Israeli invasion in June to oust Palestinian militants in southern Lebanon when Iran, in an effort to export its brand of Islamism following its revolution of 1979, decided to support the creation of its own militia in Lebanon with the intent of creating an Islamic state. Several factors such as Lebanon's civil war starting in 1975, the empowerment of the Shi'a in Lebanon throughout the 1970s and early 1980s, and the Israeli invasion all contributed to this decision to form a new militia. The decision of Amal, an already existing Shi'a militia in Lebanon, to join the National Salvation Authority, which would help to oversee Lebanon during this crisis period, did not bode well with Tehran either. The Iranians saw this body not as a means of unifying Lebanon but rather it "symbolized the Western takeover of Lebanon and the perpetuation of the 'Zionist occupation' of the country".⁴⁹ Iran saw the decision by Nabih Berri, Amal's leader, to join the National Salvation Authority as a sin by both Amal and Berri "without expiation".⁵⁰ As a result, in late 1982 Iran sent several hundred members of its Revolutionary Guard also known as Pasdaran to help stand up and train this new Shiite organization.⁵¹ In addition, Abbas Musawi, second in command of Amal's militia forces, split from Amal taking with him a number of fighters and headed out to Baalbek in the Beqaa

⁴⁹ Shapira, 121.

⁵⁰ Ibid., 121.

⁵¹ Shapira, 122 and Harik, 40.

Valley, seizing Amal's assets in the area and calling his new group *Amal Islami*.⁵² Rapidly other groups began to link up with this emerging force in Baalbek, as the city began taking on a very Islamic feel to it. Shimon Shapira illustrates in his piece "Origins of Hizballah" that in Baalbek "the sale of liquor was prohibited, women were compelled to dress modestly, and the city began to resemble Iran in every way" with huge posters of Ayatollah Khomeini and other Iranian leaders helping to intensify this new "Iranian" atmosphere.⁵³ This radical Islamic group, trained & financed by the Iranians, had clear objectives in these early years: a holy war to drive out foreign forces, followed by the ouster of the Christian government and the installation of an Islamic regime.⁵⁴

1. The Early Years

Throughout the 1980s Hezbollah was synonymous for some of the most egregious acts of terrorism in the Middle East. The year 1983 would mark the beginning of Hizballah's violent campaign to rid Lebanon of both Israel Defense Forces and the international peacekeeping troops. On 23 October 1983, Hizballah blew up the United States Marine Corps Barracks in Beirut killing 240 U.S. service personnel, as well as nearly simultaneously blowing up a French Paratroop barracks nearby killing 58. IDF headquarters and other key Israeli positions quickly became targets for Hizballah as well. The calling card for Hizballah's attacks was the suicide bomber, usually driving a truck full of explosives into a thinly protected target. The psychological effect of these suicide attacks was very evident. By 1984 the most of the Multinational peacekeeping force had withdrawn from Beirut and by 1985 the IDF withdrew to a security zone south of the Litani river. This fact prompted one Hizballah leader to acknowledge years later that "it was not the military use of suicide-bombers that led to the

⁵² Shapira, 125.

⁵³ Ibid., 123.

⁵⁴ Ibid., 128.

Israeli withdrawal in 1985, but its deterrent effect on Israeli public opinion”.⁵⁵ The group was linked to the kidnapping of several westerners to include Terry Anderson and CIA Station Chief William Buckley.⁵⁶ In addition western governments attributed several hijackings to Hizballah including Trans World Airlines 847 in 1985 which left one U.S. sailor dead. Initially seen as a competitor to the more widely popular Amal movement, Hizballah was able to push Amal out of power by the late 1980s. By 1985 Hizballah conducted 90% of the attacks against the IDF in southern Lebanon and many saw the group becoming “the sole party to conduct the struggle against Israel”.⁵⁷ Hizballah’s image as the sole resistance to Israeli aggression continued until Israel finally withdrew from its security zone in southern Lebanon in 2000.

2. The “Lebanonization Process”

“The upcoming battle, the battle for normalization,” Sheikh Hassan Nasrallah once remarked, “is much tougher than the military battle and will require greater efforts and capabilities”.⁵⁸ Initially Hizballah, with Iran’s blessing, sought to integrate Lebanon into a greater Islamic state, but the end of the civil war brought about a major shift in the group’s political outlook.⁵⁹ At this point and with the coming of the first Parliamentary elections in nearly 20 years in Lebanon in 1992, Hizballah turned to politics. The process of Hizballah’s transformation from a purely combat force into the political spectrum has been dubbed by many as the “Lebanonization process”.⁶⁰ Reasons for this shift A. Nizar Hamzeh points to in his piece entitled “Lebanon’s Hizbullah: from Islamic

⁵⁵ Magnus Ranstorp, “The Strategy and Tactics of Hizballah’s Current ‘Lebanonization Process,’” *Mediterranean Politics*, 3 (1998): 113.

⁵⁶ Norton, “Hizballah: From Radicalism to Pragmatism.”

⁵⁷ Nizar A. Hamzeh, “Lebanon’s Hizbullah: from Islamic Revolution to Parliamentary Accommodation,” American University of Beirut, 1993. <http://almashriq.hiof.no/ddc/projects/pspa/hamzeh2.html>, (accessed 16 November 2006).

⁵⁸ Ranstorp, 105.

⁵⁹ Hamzeh.

⁶⁰ See Ranstorp, *Strategy* and Hamzeh, *Lebanon’s Hizbullah*.

revolution to parliamentary accommodation,” included the change in Iran’s leadership during the early 1990s which brought on a more moderate approach to the west as well as thoughts on a great Islamic state.⁶¹ Another reason for this shift lay with the Taif Accord, largely regarded as the document ending the Lebanese civil war. As Magnus Ranstorp describes “The Taif Accord...effectively undermined the vacuum in which Hizballah operated, especially as the movement faced disarmament along with other militias by April 1991.”⁶² Hizballah recognized that in order to have influence in post-war Lebanon it would have to work within the political system formed in the aftermath of the civil war, and thus “jettisoned its commitment to establishing a system of Islamic rule in the country”.⁶³

While Hizballah always maintained some level of credibility amongst Lebanese for its armed resistance to Israel, getting involved into the political process brought with it a new sense of legitimacy unable to be attained through military force. During the war Hizballah was seen as having the “moral high ground” in the way in which it provided services to many of the Shiites inside Lebanon. Because its funding came from Iran, Hizballah was able to offer many of its social welfare programs which supplemented existing governmental agencies as opposed to many of the groups to include Amal which were seen as exploiting these same government programs.⁶⁴ Even in the last decade while the government continued to rebuild the entire country, Hizballah continued to expand its social and public assistance work and “reap the rewards that spin off from these endeavours”.⁶⁵ Yet Hizballah extended these services across sectarian lines. While most services are located in Shi’a areas, Norton points to

⁶¹ Hamzeh.

⁶² Ranstorp, 116.

⁶³ Norton.

⁶⁴ Judith Palmer Harik, “Between Islam and the System: Sources and Implications of Popular Support for Lebanon’s Hizballah,” *Journal of Conflict Resolution*, 40 (1996): 51.

⁶⁵ Judith Palmer Harik, *Hizballah: The Changing Face of Terrorism*, (New York: I.B. Tauris & Co, Ltd, 2004), 93.

hospitals and clinics that “also treat all walk-in patients, regardless of political views or their sect, for only a small fee.”⁶⁶ The elections of 1992 and 1996 showed the major inroads Hizballah had made in its Lebanonization process winning several seats in Parliament. Hizballah had transformed, yet as would be shown throughout the 1990s, the organization still maintained its teeth and tenacity against Israel.

3. Hizballah Today

The Lebanonization process did little to deter the aggressive nature of Hizballah to continue the fight against Israel and its occupied zone in southern Lebanon. As the years went by Hizballah continued its attacks against Israeli targets. As Norton demonstrates “the ration of Hizballah to IDF/SLA (Southern Lebanese Army) casualties has been less than 2:1, whereas in the past it was more than 5:1”.⁶⁷ After two unsuccessful attempts to try and quiet Hizballah along the security zone, Israel finally announced in 1999 its unilateral withdrawal from Lebanon to be completed by 2000. Israeli Operations such as Accountability in 1993 and Grapes of Wrath in 1996, did little but to alienate the Lebanese much the same as operations in 1978 did. The one difference between these two time periods being that Hizballah maintained a credibility and legitimacy that the PLO never had in southern Lebanon amongst the Lebanese. Effects of this are shown in a series of surveys conducted by Judith Harik published in 1996. In one particular survey Shi’a when asked which political party contributed most to Shiites educational, health, and social needs, picked Hizballah with 64% of votes, compared with 20% for Amal and other minor groups receiving the other 16%.⁶⁸ As Israel slowly pulled out of southern Lebanon, Hizballah moved in. While a fear existed amongst many in Lebanon of reprisals against Shi’as living inside Israel’s occupied zone, Hizballah, now firmly

⁶⁶ Augustus Richard Norton, *Hezbollah*, (Princeton NJ: Princeton University Press, 2007), 110.

⁶⁷ Norton, “Hizballah: From Radicalism to Pragmatism.”

⁶⁸ Harik, *Support for Lebanon’s Hizballah*, 56.

part of the political process took a different view. Harik points out that in the vacuum of Israel's pullout in Southern Lebanon, Hizballah only stood to gain by welcoming back the population and putting these Lebanese under Hizballah's wing as "the last thing Hizballah would want to do is alienate them and lose their votes!"⁶⁹

Even in the aftermath of the Israeli withdrawal, Hizballah, who many felt would disarm since their goal of pushing out Israel had been achieved, continued its resistance. Targeting the disputed Sheb'a Farms region became Hizballah's new rallying cry.⁷⁰ The conflict in the summer of 2006 began with the kidnapping of the two Israeli Soldiers in Sheb'a Farms area. One of the key pillars of Hizballah has always been its resistance to Israel with regards to southern Lebanon. The 2006 Summer War reiterated this claim. Furthermore, Hizballah still identifies itself with the Sunni group Hamas in the Palestinian territories of Gaza and the West Bank. As Hizballah has changed itself to meet the new challenges of Lebanon, the organization has also expanded to meet these new needs, branching out from being just a Shi'a militia to reaching out to all of Lebanese society.

D. HIZBALLAH'S ORGANIZATION

1. Overview

Hizballah has continually adapted its organizational structure to keep pace with the changing environment that it faces in Lebanon. By being a highly flexible combination of capabilities from militia and resistance group to social-welfare outlet to propaganda machine, Hizballah shows just how capable it is at the dawn of the 21st century. Mona Harb points out that Hizballah's success is "because they operate as an integrated and holistic network. This network

⁶⁹ Harik, *Hizballah*.

⁷⁰ This region had been occupied since 1967 by Israel after capturing it from Syria as part of the Golan Heights, but was traditionally seen as part of Lebanon.

produces individual and collective meaning to its beneficiaries, which in turn, explains how and why Hizballah is legitimized as a dominant order among Lebanese Shi'a".⁷¹ A. Nizar Hamzeh's provides perhaps one of the best models for the structure below:

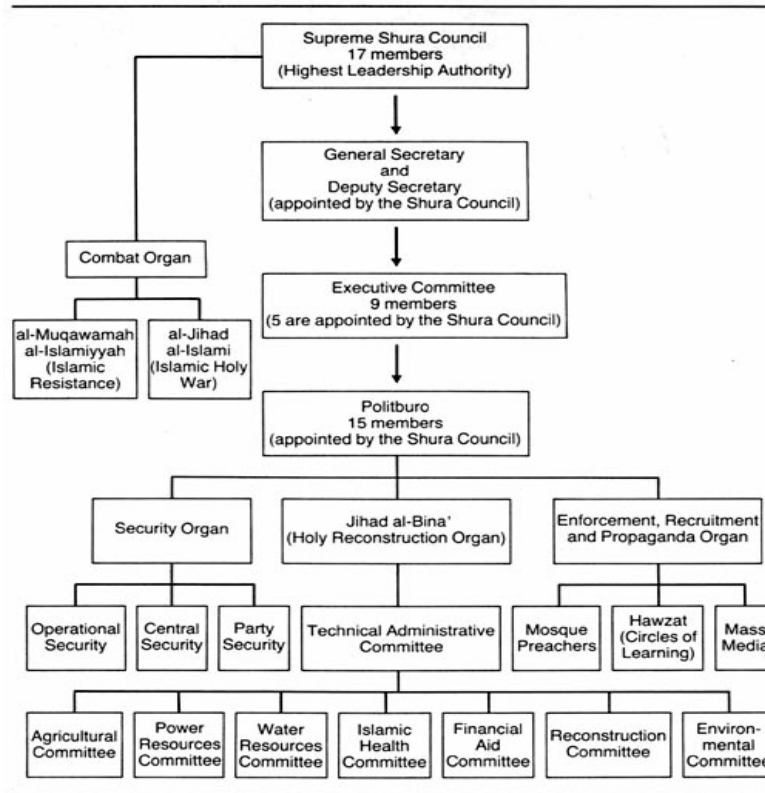

Figure 4. Hizballah Organizational Structure⁷²

While the entire structure is beyond the scope of this paper, much of it is worth noting, along with these leaders and will be explained below.

2. Chain of Command

At the top of the structure sits the Supreme Shura Council or *Majlis al-Shura* composed of 17 members and has the highest authority in the party and is

⁷¹ Mona Harb and Reinoud Leenders, "Know thy enemy: Hizballah, 'terrorism' and the politics of perception," *Third World Quarterly* 26 (2005): 187.

⁷² Hamzeh.

“charged with legislative, executive, judicial, political, and military affairs and with overall administration of the party” as Hamzeh describes in his work.⁷³ Key members include both clergy and para-military leaders in the group as well as the Secretary General and his deputy. Furthermore as Hamzeh describes “no policy is legitimate without clearance from the Supreme Shura Council”.⁷⁴ Below the *Majlis al-Shura*, is the Executive Shura and the Politburo both established in 1989. Whereas the Executive Shura holds a place of overseeing district actions represented by the 5 district heads, the Politburo has the task of coordinating work for the various party committees underneath it. It is from the Politburo that Hizballah’s representatives to Parliament often come from. Before launching into further discussion on the various party committees and their roles in Hizballah it is important to briefly look at its leader.

No man more than Hassan Nasrallah has come to symbolize Hizballah in the last fifteen years. Currently he serves as the Secretary General, a post he took over in 1992. Nasrallah grew up in southern Beirut working for his father, a grocer until the civil war started. Initially part of Amal, Nasrallah chose to join the clergy and studied in Najaf, Iraq in the late 1970s. By the early 1980s Nasrallah returned to Lebanon and joined the new Shiite militia, Hizballah, rising quickly through the ranks as a top field commander.⁷⁵ In 1992 following the death of his mentor, Musawi, Hassan Nasrallah took over Hizballah and led them through the Lebanonization process, further strengthening Hizballah’s legitimacy in society. Furthermore, he is not seen as some sort of political elite in Lebanon but rather “charismatic and pointed”.⁷⁶ In 1997 one of his sons was killed by an Israeli raid in southern Lebanon and this act helped to further increase his legitimacy amongst Lebanese because he was seen as a real person who shared a sense

⁷³ Hamzeh.

⁷⁴ Ibid.

⁷⁵ Annia Ciezadlo, “Beirut Dispatch: Sheik Up,” *The New Republic*, 7 August 2006. <http://web.ebscohost.com/ehost/pdf?vid=2&hid=122&sid=0a67bf8e-7e13-4a65-9489-459441a86676%40sessionmgr108> (accessed 7 June 2007).

⁷⁶ Ibid.

of loss like so many in Lebanon. As Annia Ciezadlo describes “he has already earned the distinction of being the only Arab leader to evict Israel from Arab land without having to sign a peace treaty”.⁷⁷

3. Support Organizations

As mentioned previously Hizballah maintains several key components or organs in which they carry out various functions of the organization. Of the 4 organs, only the combat organ reports directly to the Supreme Shura Council, the top ruling body of Hizballah, the other three report through the Politburo. Below is a detailed description of each.

a. Combat Organ

The first of the four organs is that of the combat organ and is composed of two parts: the *al-Muqawamah al-Islamiyyah*, better known as the Islamic Resistance, and the *al-Jihad al-Islami* (Islamic Holy War). Of these two the Islamic Resistance has the role of “suicidal attacks against Western and Israeli targets,” while Islamic Holy War has the mission of more conventional attacks.⁷⁸ It is important to note that Islamic Resistance is not an independent combat army; rather it is only composed of members who are combatants in times of need, making it “difficult for the party’s enemies to strike at them for they would have to strike at the whole population in order to do so.”⁷⁹

b. Enforcement, Recruitment and Propaganda Organ

The next organ is the Enforcement, Recruitment and Propaganda which oversees all three of these areas. Hizballah has a network of preachers in Mosques preaching their message and recruiting converts to the cause. Research and Propaganda runs two radio stations for the organization: *Sawt al-*

⁷⁷ Ciezadlo.

⁷⁸ Hamzeh.

⁷⁹ Ibid.

Iman (Voice of Faith), and *Sawt al-Nidal* (Voice of Struggle) as well as party magazines and newspapers. The Research and Propaganda wing also is responsible for the operation of Hizballah's own television station, *al-Manar* (The Beacon), which is now available by satellite throughout the Middle East. *Al-Manar* would become a key outlet for information and propaganda during the recent conflict and will be discussed in further detail later on.

c. Holy Reconstruction Organ

The other organ is the *Jihad al-Bina*, the Holy Reconstruction Organ. Like the name implies this is the wing of Hizballah oversees eight separate committees providing a range of support to members, new recruits and supporters of the organization. The committees provide a wealth of services ranging from health care, to water and power to agricultural issues to having its own construction companies capable of rebuilding homes and infrastructure. Hamzeh points out this committee "repaired and maintained between 1988 and 1991 over 1000 homes damaged by Israel and other attacks".⁸⁰ Funding as mentioned before comes directly through Iran and has increased over the years from \$1.8 million in 1993 to nearly \$450 million following the Summer 2006 conflict.⁸¹ Thus by closer examination Hizballah, while not only armed with weapons for conventional military and terrorist attacks, is quite capable of conducting PSYOP through its own media sources and social welfare projects through its Reconstruction committee.

d. Security Organ

The final organ to be discussed is the Security organ which is divided into three separate parts. The first part is that of Party security and as

⁸⁰ Hamzeh.

⁸¹ Matthew Levitt, "Shutting Hizballah's 'Construction Jihad'" Policy Watch #1202, *The Washington Institute for Near East Policy*, 20 February 2007. <http://www.washingtoninstitute.org/templateC05.php?CID=2571> (accessed 20 March 2007).

Hamzeh describes “is in charge of protecting party leaders and members”.⁸² The next branch is that of the Central Security which operates a network of surveillance and intelligence gathering operations inside and outside the country. Magnus Ranstorp believes that this branch of the security organ most likely has elements monitoring internet sites for intelligence taken from Israeli press sources about undercover Israeli units operating inside Lebanon, similar to our own open source intelligence initiatives.⁸³ The final branch, the Operational Security section, oversees decisions made by the greater Security organ against Hizballah’s enemies. Thus Hizballah with this imbedded Security capability is more than able to meet the challenges of gathering intelligence and providing security to its members.

E. CONCLUSION

As shown on the previous pages, Hizballah has transformed itself over the last quarter century into a very robust and fluid organization. Some have ventured to label it “the best guerrilla force in the world.”⁸⁴ Having reached out across sectarian divides inside Lebanon and remodeled themselves as to gain credibility and legitimacy, it is clear that Hizballah shows no signs of disappearing off of the Middle East’s stage any time soon. Along each transformative step, the information operations capabilities of Hizballah have also developed. From the haunting images reflective of suicide bombings in the early 1980s to their open source intelligence gathering techniques to the use of satellite television stations such as *al-Manar*, Hizballah’s transformation has made it quite a formidable foe in today’s information age.

⁸² Levitt.

⁸³ Ranstorp, *The Strategy and Tactics of Hizballah’s*, 110.

⁸⁴ Edward Cody and Molly Moore, “The Best Guerilla Force in the World’; Analysts Attribute Hizballah’s Resilience to Zeal, Secrecy and Iranian Funding,” *The Washington Post*, 14 August 2006, final edition. <http://proquest.umi.com.libproxy.nps.navy.mil> (accessed 7 June 2007).

THIS PAGE INTENTIONALLY LEFT BLANK

IV. DECEPTION IN THE 2006 SUMMER CONFLICT

The surprises that I promised you will begin starting now. Now, out at sea off the coast of Beirut an Israeli military vessel that attacked our infrastructure, that struck the homes of our people, our civilians; you can see it burning. It will sink and with it dozens of Zionist Israeli troops. This is the beginning. There will be a lot more said before the end.⁸⁵

Sheikh Hassan Nasrallah
14 July 2006

A. INTRODUCTION

The 2006 summer conflict between Israel and Hizballah was six years in the making. As it played out certain things became quite clear: Hizballah was ready, Israel was not. Over and over again as the war unfolded not only in southern Lebanon but on the televisions and computers of the rest of the world, the power of Hizballah's deception plan played out. As one reporter describes:

From the onset of the conflict to its last operations, Hezbollah commanders successfully penetrated Israel's strategic and tactical decision-making cycle across a spectrum of intelligence, military and political operations, with the result that Hezbollah scored a decisive and complete victory in its war with Israel.⁸⁶

Key to their success was Hizballah's use of deception in support of their overall strategy. By all means available, Hizballah used deception in the prosecution of the conflict with very successful results. This chapter will examine four instances of deception and measure their effectiveness.

Prior to launching a discussion on the deception campaign in the summer conflict, this paper will examine those events leading up to the conflict as well as

⁸⁵ Hassan Nasrallah, *Address of General Secretary of Hizballah*, 14 July 2006, translated by Eric Mueller, <http://electronicintifada.net/bytopic/historicalspeeches/447.shtml> (accessed 1 May 2007).

⁸⁶ Alistair Crooke and Mark Perry, "How Hezbollah Defeated Israel: Part 1: Winning the Intelligence War," *Online Asia Times*, 13 October 2006, http://www.atimes.com/atimes/Middle_East/HJ12Ak01.html, (accessed 15 November 2006).

describing the other critical piece to deception, Hizballah's use of denial in the conflict. By demonstrating how effective Hizballah's use of denial was, it will be easier to show how their deception worked. Furthermore, in the discussion of deception in Chapter II, several criteria were by which to evaluate Hizballah's acts. These criteria include the objectives and categories of deception listed by Daniel & Herbig , the techniques listed by Dunnigan and Nofi, and the sensors utilized to pass the information or signal. An example table with these criteria is listed below:

CRITERIA	EVALUATION
Three Objectives? - condition the target's beliefs? - influence the target's actions? - target's actions must benefit the deceiver?	
Sensors targeted?	
Type: M-type or A-type?	
9 Characteristics? (concealment, camouflage, false and planted information, ruses, displays, demonstrations, feints, lies, and insight)	

Table 2. Deception Evaluation example

By analyzing these acts of deception against these criteria it will prove how successful Hizballah's efforts truly were. There are four deception acts which will be analyzed in this chapter. The following table outlines each of the acts with a brief description:

ACT	LEVEL OF WARFARE	DESCRIPTION
Fake Bunkers	Tactical	Hizballah built fake bunkers to confuse Israeli intelligence about the actual location of their bunkers
Electronic Warfare Bluff	Tactical/Operational	Hizballah bluffed about being able to listen into Israeli secure frequency hopping radio systems.
The Media	Operational	Hizballah used the media as their tool to conceal their use of civilian areas to launch rockets.
Hijacking the internet	Tactical/Operational	Hizballah “hid” on internet service providers in the US to maintain its capability to broadcast via broadband.

Table 3. Deception Operations Carried Out by Hizballah

Before further exploring these acts however, a discussion on the events of the conflict must occur as well as the denial operations which supported them.

B. BACKGROUND

As described in Chapter III, the conflict between Israel and Hezbollah is by no means new. Hezbollah has been fighting Israel in a guerrilla-type war since its creation in the early 1980s. In 1985 Israel pulled out of much of Lebanon into a security zone along its northern border following a nearly three year occupation of most of Lebanon south of Beirut. Israel hoped to stabilize its northern border, Hezbollah however, remained persistent with attacks against Israeli military targets in this area. Twice Israel launched sustained ground offensives outside of their self-proclaimed security zone in attempts to stop Hezbollah’s attacks. The first, called Operation Accountability, was launched in 1993 by the IDF with the intent of putting pressure on Syrian and Lebanese forces to weaken Hezbollah, but to no avail. The second operation, launched in 1996, called Operation Grapes of Wrath, was again aimed at putting pressure on Syrian and Lebanese forces to weaken Hezbollah, and it too failed. By the end of the 1990s following nearly two decades of conflict, Israel unilaterally withdrew from its

southern security zone in Lebanon after the loss of nearly 1,500 soldiers and low public support for the mission. This withdrawal, as Avi Jorish points out in his book *Beacon of Hatred*, “led many to believe that Hizballah had defeated Israel, and the party’s reputation consequently soared throughout the entire Arab world.”⁸⁷ Following the withdrawal, Israel and Hezbollah engaged in a quasi-peace along the southern Lebanese border known commonly as the “Blue Line,” monitored by members of the United Nations Interim Force in Lebanon (UNIFIL).

Between UNIFIL, Israel and Hizballah a phony war developed on the Blue Line between Israel and Lebanon. Nicholas Blanford in *Jane’s Intelligence Review* describes the situation between Hezbollah and the IDF in a report from 2006: “The IR (Islamic Resistance) had been attacking the IDF along the Blue Line for six years in a finely calibrated campaign of periodic hit-and-run raids, roadside bombings and artillery bombardments.”⁸⁸ The goal of these actions was, as Blanford describes, to “maintain pressure on the IDF without provoking Israel into a massive retaliation that could harm Hizballah’s domestic popularity.”⁸⁹ Furthermore, Hezbollah, in an effort to gain the release of its own Israeli held prisoners, began a new strategy: the kidnapping of Israeli soldiers. Hezbollah made five attempts before the July 2006 kidnappings to abduct IDF personnel. Israel, already frustrated by the previous actions of Hezbollah, had had enough by early this year and a senior IDF leader stated to the UNIFIL commander that if Hezbollah attempted another kidnapping, “we will burn Beirut”.⁹⁰ While this information was passed on to the Lebanese government, no one is for certain if it was passed onto Hezbollah’s leadership.⁹¹ Thus the situation was quite tense by the early summer of 2006.

⁸⁷ Avi Jorish, *Beacon of Hatred: Inside Hezbollah’s Al-Manar Television*, (Washington: Washington Institute for Near East Policy, 2004), 14.

⁸⁸ Nicholas Blanford, “Deconstructing Hizballah’s Surprise Military Prowess,” *Jane’s Intelligence Review*, 1 November 2006, <http://www2.janes.com.libproxy.nps.navy.mil/> (accessed 7 June 2007).

⁸⁹ Ibid.

⁹⁰ Ibid.

⁹¹ Ibid.

Even in the days leading up to the 12 July incident, Hezbollah's leadership, aware of the importance of the tourist season to Lebanon's economy, reassured Lebanese Prime Minister Fouad Siniora that no actions would be taken by Hezbollah against Israel.⁹² Meanwhile, standing orders to Hezbollah's Islamic Resistance units along the Blue Line went unchanged: "exploit Israeli military weaknesses" and abduct IDF soldiers given the opportunity.⁹³ Under these circumstances both sides stood poised for a clash on the morning of 12 July 2006.

At a little after nine in the morning local time, an IDF patrol consisting of two "Humvee" type-vehicles came under fire from IR forces along the Blue line. Within minutes, the patrol, out of communication range with higher headquarters and in a blindspot from IDF covering fire, had two dead, three wounded and Eldad Regev and Ehud Goldwasser lay in Hezbollah's hands.⁹⁴ In the following hours, both Hezbollah and the IDF embarked on a series of skirmishes along the border resulting in several IDF soldiers killed and injured. In Beirut senior Hezbollah leaders attempted to calm Lebanese officials' fears about Israeli reprisals, even going as so far to speak to the Prime Minister and Minister of the Interior.⁹⁵ This time, unlike previous attempts, Israel did react swiftly. Within hours Israeli warplanes attacked Hezbollah positions along the Blue Line and destroyed several bridges on the Litani River, in an attempt to isolate the southwest portion of the country. As a response, Hezbollah began to unleash scores of Katyusha rockets into northern Israel. A new chapter in the battle between Israel and Hezbollah had begun.

As the bullets and rockets began to fly across the border, both sides identified strategic objectives for the conflict. Anthony Cordesmen from the

⁹² Anthony Shadid, "Inside Hezbollah, Big Miscalculations," *The Washington Post*, 8 October 2006, final edition, <http://www.washingtonpost.com/wp-dyn/content/article/2006/10/07/AR2006100701054.html> (accessed 13 December 2006).

⁹³ Crooke and Perry.

⁹⁴ Crooke and Perry.

⁹⁵ Blanford.

Center for Strategic and International Studies, points out that from the onset of hostilities the Israeli Cabinet under the direction of Prime Minister Ehud Olmert laid out five key Israeli objectives for the war:⁹⁶

- Destroy the “Iranian Western Command” before Iran could go nuclear
- Restore the credibility of Israeli deterrence after the unilateral withdrawal from Lebanon in 2000 and Gaza in 2005, and countering the image that Israel was weak and forced to leave.
- Force Lebanon to become and act as an accountable state, and end the status of Hezbollah as a state within a state.
- Damage or cripple Hezbollah, with the understanding that it could not be destroyed as a military force and would continue to be a major political actor in Lebanon.
- Bring the two capture Israeli soldiers back alive without major trades in prisoners held by Israel.

On the other side, Hezbollah had its own objectives. Their main objective lay in humiliating Israel by sheer survival as Hezbollah’s Secretary-General Hassan Nasrallah pointed out in an interview on July 21st. Nasrallah spoke that “The victory we are talking about is when the resistance survives. When its will is not broken, then this is a victory”.⁹⁷ While not much else is known of their objectives, because of the tight security within Hezbollah, perhaps another goal can be found in Ron Schliefer’s piece, “Psychological Operations: A New Variation of an Age Old Art: Hezbollah versus Israel.” In this article Schliefer

⁹⁶ Anthony H. Cordesman, “Preliminary “Lessons” of the Israeli-Hezbollah War,” *Center for Strategic and International Studies*, 17 August 2006. http://www.csis.org/media/csis/pubs/060817_isr_hez_lessons.pdf (accessed 21 November 2006), 4-5.

⁹⁷ David Makovsky and Jeffrey White, “Lessons and Implications of the Israel-Hezbollah War: a Preliminary Assessment,” *The Washington Institute for Near East Policy*, October 2006, Policy Focus #60. <http://www.washingtoninstitute.org/pubPDFs/PolicyFocus60.pdf> (accessed 29 November 2006), 9.

describes the psychological warfare executed by Hezbollah in their campaign to push Israel out of southern Lebanon leading up to the 2000 withdrawal. Hezbollah, Schliefer exerts, “launched a...guerilla war psychologically waged” meaning that the organization attacked IDF soldiers, not to conquer land, but as an end in itself.⁹⁸ By drawing out and killing IDF soldiers, Hezbollah had the objective of reducing Israeli morale and public opinion to the point where they would withdrawal as they had done in 2000. Thus much of the Hezbollah’s battle plan lay in the use of information operations to wear down Israel.

The war played out on land, in the air, and at sea across Lebanon and northern Israel. Shortly after the commencement of hostilities, Israel began a naval blockade of Lebanese ports, hoping to cut off arms shipments to Hezbollah. From the air, Israeli Air Force launched what seemed like a brutal series of attacks first aimed at Hezbollah missile and rockets sites in southern Lebanon, but then turning on critical Lebanese infrastructure to include crucial road intersections, bridges, and even the Beirut airport, in images reminiscent of Lebanon in the mid-1980s. Despite the Israeli Air Force destroying 54 long range rocket and missile launch sites in 39 minutes on the first day of the conflict, Hezbollah continued to reign down shorter range Katyusha rockets on Israel’s northern towns and villages daily.⁹⁹ By the end of the first 72 hours, Israel’s air campaign showed little results of degrading Hezbollah’s capabilities and the chances of Israel achieving a decisive victory became “increasingly, and highly unlikely”.¹⁰⁰

By the 17th of July, Israel turned to the ground option to combat Hezbollah in the south of Lebanon. Ground forces yielded little more than the air option as IDF forces quickly found that the guerrilla force in front of them was quite exceptional. “We didn’t know what hit us,” spoke one IDF soldier after a battle

⁹⁸ Schleifer, 5.

⁹⁹ Uzi Mahnaimi, “Humbling of the Supertroops Shatters Israeli Army Morale,” The Sunday Times, 27 August 2006. http://www.timesonline.co.uk/article/0,,2089-2330624_1,00.html (accessed 20 November 2006).

¹⁰⁰ Crooke and Perry.

with Hezbollah militia forces to an interviewer with *The Sunday Times*, “In seconds we had two dead”.¹⁰¹ As units pushed north, many found themselves surrounded at times, fighting a true asymmetric threat as guerrillas swarmed seemingly from all sides with anti-tank missiles and other weapons. Because of this slow going, the ground war had to be expanded to account for the problems now faced as Israel’s “blitzkrieg” style assault grinded to a halt.

In early August, with Israel unable to score a decisive victory, the UN pushed all sides in the conflict towards a cease-fire. On the 14th of August, both Hezbollah and Israel agreed to the ceasefire proposal and the guidelines of UN resolution 1701. In 34-days of fighting Israel sent nearly 30,000 soldiers to fight in southern Lebanon, while reports of Hezbollah’s numbers are considerably less, perhaps as low as 3000, or just one brigade’s worth of militia.¹⁰² Even on the last day before the ceasefire, Hezbollah rockets and missiles continued to rain down on Israel, despite all actions Israel had taken to that point. UN Resolution 1701 provided that the Lebanese Army, under the observation of increased UNIFIL force would ensure Hezbollah leaves southern Lebanon, the likes of which remain to be seen. At the termination of hostilities little had changed, and Hezbollah was left still standing, deception having played a key role at the tactical and operational levels to shape the outcome of the battle.

C. HIZBALLAH’S DENIAL OPERATIONS

Even before the conflict started, Hizballah began its campaign to control the information battlespace with Israel. The ability by Hizballah to maintain operational security and deny Israel the critical information it would need to adjust its battleplans during the course of the conflict would have significant repercussions. By controlling the information environment Hizballah in effect dictated the rules of the game and was able to utilize deception. As mentioned in

¹⁰¹ Mahnaimi.

¹⁰² Alistair Crooke and Mark Perry, “How Hezbollah Defeated Israel: Part 2: Winning the Ground War,” *Online Asia Times*, 13 October 2006. http://www.atimes.com/atimes/Middle_East/HJ13Ak01.html, (accessed 15 November 2006).

Chapter II, key to denial is having access to the enemy's sensors. There are two strikingly different examples of how Hizballah targeted Israeli sensors and exploited these sensors to support their war effort. The first comes through more traditional means, namely the use of spies. The second, broader example, deals with the accessibility of information in a closed society versus an open one. Both of these methods of denial significantly contributed to both the war effort and the deception plans employed throughout.

The use of spies is one of the oldest methods of gathering intelligence known in warfare and Hizballah made good use of it. What was significant about Hizballah's use of spies was that they had made significant inroads in the previous ten years in counterintelligence efforts against Israel. In the summer of 2006 this work paid off. In an *Asia Times Online* article, authors Alistair Crooke and Mark Perry write "over a period of two years, Hezbollah's intelligence officials had built a significant signals-counterintelligence capability...Hezbollah had identified key Israeli human-intelligence assets in Lebanon."¹⁰³ They go on to add that in the month before the abduction of the two IDF personnel, the Lebanese government with assistance from Hizballah broke up an Israeli spy ring inside of Lebanon. Finally, they also remark that "Hizballah had successfully 'turned' a number of Lebanese civilian assets reporting on the location of major Hezbollah military caches in southern Lebanon to Israeli intelligence officers."¹⁰⁴ As will be shown, these actions had dire consequences for the Israelis and were critical to Hizballah's deception plan. In effect Hizballah effectively closed down Israel's human intelligence capability, often regarded for its "intelligence dominance" in previous conflicts against its Arab neighbors.¹⁰⁵

The other key element to Hizballah's denial campaign involved the high degree of internal security within this organization. Hizballah, as mentioned

¹⁰³ Crook and Perry, "How Hezbollah Defeated Israel: Part 1: Winning the Intelligence War."

¹⁰⁴ Ibid.

¹⁰⁵ Richard Shultz and Roy Godson, "Intelligence Dominance," *The Weekly Standard*, 31 July 2006, 22.

previously is often thought of as a “state within a state,” and during this campaign it demonstrated the high level of security it had amongst its members. There were two ways in which Hizballah controlled its information footprint. The first involves its soldiers and militia on the ground. So secretive was Hizballah in the preparations for the conflict it has been reported that “no single commander knew the location of each bunker” from which they would be fighting.¹⁰⁶ In addition after being hidden during several attempts on his life, Secretary General Hassan Nasrallah remarked on how good Hizballah’s security apparatus was when he said “Not even I knew where I was.”¹⁰⁷

Alongside the individual security and denial that Hizballah exhibited, they tightly controlled open source information coming out of Lebanon. This allowed Hizballah to tell their story better than Israel, because there was only one story to tell and then only told by a few high ranking people in Hizballah’s organization. Hizballah’s information campaign opens a debate in some circles on lessons from the war. Marvin Kalb describes it this way:

If we are to collect lessons from this war, one of them would have to be that a closed society can control the image and the message that it wishes to convey to the rest of the world far more effectively than can an open society, especially one engaged in an existential struggle for survival. An open society becomes victim of its own openness...A closed society conveys the impression of order and discipline; an open society, buffeted by the crosswinds of reality and rumor, criticism and revelation, conveys the impression of disorder, chaos and uncertainty...¹⁰⁸

Hizballah never admitted how many casualties it took during the fighting either, another indicator of the high level of security it maintains.¹⁰⁹ Thus having a closed society with tight control over the media picture greatly enhanced Hizballah’s ability to control information broadcasted to the rest of the world.

¹⁰⁶ Crook and Perry, “How Hezbollah Defeated Israel: Part 1: Winning the Intelligence War.”

¹⁰⁷ Crooke and Perry.

¹⁰⁸ Kalb, 5.

¹⁰⁹ Cordesman, 7.

Hizballah's closed society greatly contributed to their overall denial capabilities because it produced a limited information signature greatly restricting information Israel could obtain through open source means.

Again and again throughout the conflict these two key denial operations of Hizballah's would be very significant to only the overall conflict but more importantly to this discussion, Hizballah's deception operations. The focus now will be to examine these operations in depth and evaluate their effectiveness.

D. THE BUNKERS

As mentioned earlier, after the first 72 hours of airstrikes by Israel against targets across Lebanon, Israeli leaders decided to begin limited ground incursions into southern Lebanon. Very quickly the IDF discovered they were in for a surprise. Hezbollah began to prepare its plan for future battle on the heels of Israel's earlier withdrawal from southern Lebanon in 2000. It was at this time that Hezbollah began a series of tasks aimed at preparing for conflict in southern Lebanon.

Hizballah undertook an elaborate construction effort of display fortifications along the Blue Line with the intent of deceiving information gathering assets such as Israeli unmanned aerial vehicles, UNIFIL observers and Lebanese spying for Israel. Meanwhile, in secret locations out of sight of information gathering assets, Hizballah built their real bunkers. It was a classic example of military deception; Hezbollah purposely lured observers into believing that the openly visible bunkers should be targeted if conflict occurred. At the same time, Hezbollah's construction of real bunkers went forward "in areas kept hidden from the Lebanese population" as *Asia Time* reports Alistair and Crooke note. They go on to add that "Nearly 600 separate ammunition and weapons bunkers were strategically placed in the region south of the Litani".¹¹⁰ Senior IDF

¹¹⁰ Crooke and Perry, "How Hezbollah Defeated Israel: Part 1: Winning the Intelligence War."

commanders reported when asked about these bunkers that “It’s a very hilly area and its not easy. You cannot identify their bunkers until you’re right there.”¹¹¹

The tunnels and bunkers built in view of Israeli and UNIFIL observers along with the targets fed back to Israel through Hezbollah’s counterintelligence operations identified key emplacements that did not, in fact, exist.¹¹² As one former UNIFIL observer describes “We were meant to see these things...They were not making any effort to stop us looking...they really fooled us on that one”.¹¹³ In comparison to the decoy bunkers another UNIFIL officer reports to *Janes* on the real bunkers: “We never saw them build anything. They must have brought the cement in by the spoonful.”¹¹⁴ The deception of the bunkers was reinforced by the tight secrecy that Hezbollah maintained through all the years leading up to the battle. Thus when Israel crossed over into southern Lebanon much of the intelligence driving their planning would prove false and Israeli ground forces paid the price for this intelligence failure.

Evaluating this case of tactical deception shows just how successful it really was. Furthermore, based on the Dunnigan & Nofi listing of examples, these fake bunkers are prime examples of “displays,” in that they attempt to “make the enemy see what isn’t there” and that “you’re simply attempting to make it appear other than what it really is.”¹¹⁵ When looking at the type of deception used, based on Daniel & Herbig’s model, these fake bunkers fall into the realm of misleading types or M-type because these displays took attention off of the main effort: Hizballah’s construction and defense of the real bunker system. The overall effectiveness can be measured in the statements above

¹¹¹ Nicholas Blanford, “Hizbullah’s Resilience built on years of homework; Meticulous planning and a thorough understanding of Israeli military doctrine both play into its success,” *Christian Science Monitor*, 11 August 2006. <http://proquest.umi.com.libproxy.nps.navy.mil> (accessed 7 June 2007).

¹¹² Crooke and Perry, “How Hezbollah Defeated Israel: Part 1: Winning the Intelligence War.”

¹¹³ Shadid.

¹¹⁴ Blanford, “Deconstructing Hizbullah’s Surprise Military Prowess.”

¹¹⁵ Dunnigan and Nofi, 19.

taken from UNIFIL representatives and IDF leaders in that they knew virtually nothing about the extent of the real bunkers, and focused almost entirely on the fake ones. This case serves as a textbook example of tactical deception in warfare. Below is a summary of this deception operation:

CRITERIA	EVALUATION
Three Objectives: - condition the target's beliefs? - influence the target's actions? - target's actions must benefit the deceiver?	- Israel felt it knew where Hizballah's bunkers were and attacked them early on. - Hizballah was able to operate from the real bunkers with little threat from Israeli attacks
Sensors targeted?	Israeli UAVs, UNIFIL observers, Lebanese spies.
Type: M-type or A-type?	M-type: the fake bunkers served to mislead the IDF's attacks.
9 Characteristics? (concealment, camouflage, false and planted information, ruses, displays, demonstrations, feints, lies, and insight)	Display: making the enemy see what isn't there. Israel and UNIFIL saw bunkers but did not see the real bunkers until combat began

Table 4. Evaluation of Bunker Deception

E. ELECTRONIC WARFARE BLUFF

In what was another successful use of deception, Hizballah's electronic warfare (EW) bluff also contributed to their overall battle plan. From the onset it appeared that Hezbollah was using a new weapon unseen before in the conflict between it and Israel: EW. Reports came out that Hezbollah, probably assisted with Iranian supplied technology, was able to intercept Israel's secure frequency-hopping radio transmissions and monitor information on troop movements, casualty reports and supply routes.¹¹⁶ As one Israeli officer claims, "They monitored our secure communications in the most professional way." adding that, Hezbollah would "send it [casualties' names] to their *al-Manar* TV, which

¹¹⁶ For further information on this see: Mohamad Bazzi, "Hezbollah Cracked the Code; Technology likely supplied by Iran allowed guerillas to stop Israeli tank assaults," *Newsday.com*, 18 September 2006, <http://www.newsday.com/news/nationworld/world/ny-wocode184896831sep18,0,3091818.story?coll=ny-worldnews-print> (accessed 21 November 2006).

broadcast it almost live, long before the official Israeli radio.”¹¹⁷ This action clearly represented an effective use of PSYOP as well, designed to erode popular support for the war back in Israel. The alleged sophistication of these electronic attacks underscored how “the Shia group had higher military capabilities” than many in Israel and the United States had originally thought.¹¹⁸ While Israel did not publicly comment on what it did to counter this threat, Hezbollah’s EW attacks prompted one former Israeli general to remark that the group’s listening capabilities had “disastrous” consequences for Israel’s offensive in southern Lebanon.¹¹⁹

The news of Hizballah’s EW attacks and penetration of Israel’s secure airwaves have since proven untrue. During and immediately following the conflict both U.S. and Israeli technicians examined the problem of whether or not Hizballah could actually listen in to supposedly secure frequency-hopping technology. Then in an article published in *Aviation Week & Space Technology* in November 2006, author David Fulghum paints a more realistic picture of what Hizballah did; the title says it all: “Doubt as a Weapon.” According to Fulghum who was the first to expose this deceptive act, “Hezbollah is incapable of penetrating and exploiting the Israeli army’s tactical radio systems as it claimed it did during the recent fighting in Lebanon,” pointing to senior US electronics officials for reference.¹²⁰ The author goes on in his interview:

What they’re really doing is a very good psychological operations...one of the things you want to do is instill doubt. Hezbollah makes the pronouncement that they can read encrypted radios. They wanted the IDF troops to believe they weren’t as invulnerable as they thought. It ran like wildfire through the U.S. troops as well. What you’re witnessing is unsophisticated technology exploited by sophisticated information operations. They

¹¹⁷ Mahnaimi.

¹¹⁸ Bazzi.

¹¹⁹ Bazzi.

¹²⁰ David Fulghum, “Doubt as a Weapon,” *Aviation Week & Space Technology*, 27 November 2006, 26.

scored big time in the psychological warfare department the enemy is figuring out ways to use the information age against us.¹²¹

The article points out that what most likely occurred was confusion by other news agencies in which reporters “confused cell-phone and frequency hopping radio technology” and that listening into cell phones is a “basic signals intelligence technique” easily accomplished since “Everybody out there has a cell phone.”¹²²

In what might be considered part of the EW bluff, UNIFIL supplied another bit of evidence regarding Israel’s vulnerabilities. Marvin Kalb in his piece on the media’s role in the 2006 conflict argues that UNIFIL “published information on its official website about Israeli troop movements, information that in military circles would be regarded as ‘actionable intelligence.’” He provides examples such as key IDF units being reinforced, types of equipment traveling across the border, and which directions these units headed on various days during the battle. While it is impossible to know for certain whether Hizballah acted on the information provided by UNIFIL Kalb argues, it would be silly not to consider this as a prime source of intelligence for Hizballah to exploit.¹²³ Having already seen the resilience of Hizballah in preparing the defense of southern Lebanon and knowing that they have an OSINT capability in their organization, one cannot put it past the organization to use these sources to help put together a very credible deception of their EW prowess.

Hizballah’s EW bluff serves as another effective use of deception in this conflict, highlighting their capability to conduct more sophisticated information operations as well. While this seems to be more of a problem for Israel at the tactical level, it has operational level implications as well, specifically it forced Israel to rethink its communications network in the wake of Hizballah’s alleged EW capabilities. Again this is a case of a misleading type of deception whereby Hizballah sought to convince Israel of “the attractiveness of one wrong

¹²¹ Ibid., 26.

¹²² Fulghum, 27.

alternative,” that their communication system security had been compromised.¹²⁴ Hizballah approached spreading this information by passing false and planted information spread through sources like *al-Manar* and other media outlets and reports. Of the three objectives mentioned by Daniel and Herbig, while it is clear in the statements of Israelis that they were convinced Hizballah could listen into their radios, it is unknown how the IDF responded, but it most likely had the psychological effect of painting them as no longer invulnerable. Furthermore, on the objective of being able to benefit from the target’s actions, Hizballah benefited, albeit in a more subtle way. As the fight continued and casualties mounted, many reservists, called up for the war began to wonder why they were being sent out as cannon fodder into Hezbollah-controlled villages instead of air strikes going in first. An 11 August 2006 survey conducted by an Israeli newspaper found that 91% of respondents felt the IDF should bomb villages to take out Hezbollah versus only 8% who felt that ground forces should be used instead.¹²⁵ The results only served to benefit Hizballah because of their control of the story inside Lebanon. Israeli ground and air campaigns would only further allow Hizballah to paint a picture of “disproportionality” of Israeli acts. With all of these results in mind the EW bluff successfully served to benefit Hizballah’s overall campaign plan. The following chart summarized this example of deception:

¹²³ Kalb, 17.

¹²⁴ Daniel and Herbig, 6.

¹²⁵ Ilene Prusher, “At War, Israeli Reservists wield new weapon: opinion polls,” *Christian Science Monitor*, 16 August 2006, all edition. <http://www.csmonitor.com/2006/0816/p10s01-wome.html> (accessed 28 November 2006).

CRITERIA	EVALUATION
Three Objectives: - condition the target's beliefs? - influence the target's actions? - target's actions must benefit the deceiver?	- Israel thought Hizballah could listen to secure radio communication. Hizballah forced Israel to re-look their actions. - Hizballah appeared to be stronger than it really was through this act.
M-type or A-type?	M-type: this bluff the attractiveness of one wrong alternative (the capability to listen to secure radio comms)..
Sensors targeted?	Media, open source intelligence
9 Characteristics? (concealment, camouflage, false and planted information, ruses, displays, demonstrations, feints, lies, and insight)	Lies: Hizballah while able to listen to cell phones, could not listen to secure radio communications, but said they could.

Table 5. Evaluation of EW Bluff

Another key lesson to be learned from this example are the linkages between various information activities. While Hizballah bluffed about exactly how great their capabilities were, like many deception operations, there existed a certain amount of truth in the lie. They exercised electronic warfare by being able to listen into Israeli cell phones and exploiting other information sources as part of the deception. They also used the information they ascertained to broadcast on *al-Manar*, for PSYOP purposes. Finally, this deception tactic as Fulghum described has PSYOP implications because Hizballah “wanted the IDF troops to believe they weren’t as invulnerable as they thought” but also “ran like wildfire through the U.S. troops as well.”¹²⁶ Only months after the conflict when engineers explained the impossibility of the act did fears subside both in Israel and the United States. But by that time however, the damage had been done.

¹²⁶ Fulghum, 26.

F. MEDIA & THE BATTLE OF THE STORY

The use of the media by Hizballah in the 2006 conflict shows how effective the media can be in deception operations today. One of the many things that will be most remembered about the 2006 Summer Conflict will be the media's role in the war. The media became a primary weapon of Hizballah against Israel, and a key tool for deception. Marvin Kalb describes it this way:

During the summertime war in Lebanon, it [the internet] helped produce the first really "live" war in history...not until this war have networks actually projected in real time the grim reality of the battlefield—pictures of advancing or retreating Israeli troops in southern Lebanon, homes and villages being destroyed during bombing runs, old people wandering aimlessly through the debris, some tailed by children hugging tattered dolls, Israeli airplanes attacking Beirut airport, Hezbollah rockets striking northern Israel and Haifa, forcing 300,000 to evacuate their homes and move into underground shelters—all conveyed "live," as though the world had a front-row seat on the blood and gore of modern warfare.¹²⁷

Kalb goes on to add that because so much information was now available to the media and the public, that a shift in information flow occurred. "Once upon a time," he writes, "such information was the stuff of military intelligence acquired with considerable efforts and risk; now it has become the stuff of everyday journalism. The Camera and the computer have become weapons of war."¹²⁸ Hizballah realized the power of the manipulated media years before the conflict and exploited this to the fullest during this war. Hizballah's use of the media shows where deception can be found in information warfare. Essentially Hizballah's deception operations utilized the media to conceal the locations of its rocket sites often located in urban areas such as Qana and deflect attention from their own actions back to painting a picture of Israel's disproportionate response

¹²⁷ Kalb goes on to add that "during the first Gulf War of 1991, two American networks did broadcast one "live" report each from liberated Kuwait, and during the second Gulf War of 2003, many networks did "live" broadcasts along the U.S. invasion route from Kuwait to Baghdad." Kalb, 4.

¹²⁸ Kalb, 4.

to the kidnapping the two IDF personnel. There are two examples of how the media became a conduit of Hizballah's deception plans: through *al-Manar*, the internal media of Hizballah, and through external media, such as CNN and other world networks.

Al-Manar had long been Hizballah's primary tool of propaganda; one journalist goes so far to say that "*Al-Manar* was to Hezbollah what Pravda was to the Soviet Union."¹²⁹ In Hizballah's preparations for another conflict with Israel, expanding *al-Manar's* coverage area became a key part of their defense; it could now reach out via satellite broadcasts to Israel and much of the Arab world.¹³⁰ Satellite broadcast of *al-Manar* began on 25 May 2000, coinciding with the day that Israel pulled its last forces out of southern Lebanon, and as Avi Jorisch describes, "came to signify freedom from Israeli occupation".¹³¹ By the summer of 2006 Israelis could turn on their televisions and be exposed to daily propaganda being broadcast from Beirut including *My Blood and the Rifle*, highlighting Hezbollah fighters who died fighting against Israel, and *The Spider's House*, a talk show pointing out "the weakness of the Zionist entity" and various strategies for destroying Israel. *Al-Manar's* reporting skills had also developed over the years. Long before the U.S. picked up the concept of embedded reporters, Hizballah placed *al-Manar* reporters inside elements of the group's Islamic Resistance militia. Schliefer in his piece highlights this as a key channel of communication for Hezbollah's PSYOP capability, and goes so far as to add that Hezbollah's propaganda machine can be summed up with the words "If you haven't captured it on film you haven't fought".¹³² Furthermore, he goes on to add that "Hezbollah...regarded the video...as an object of operation" and that in the run up to the 2000 Israeli withdrawal saw how it was possible to "net huge

¹²⁹ Kalb, 23.

¹³⁰ Jorisch, 25.

¹³¹ Jorisch, 25.

¹³² Schliefer, 6.

military and psychological dividends” from a video camera and a patrol.¹³³ By the summer of 2006, *al-Manar* had mastered this technique, placing its reporters, who many believed were trained fighters, into guerrilla units having them record the battles and then broadcasting the material around the region. Even more interesting is the fact that other networks such as *al-Jazeera* and *al-Arabiya* used this footage, without checking the validity of *al-Manar*’s version of events.¹³⁴ This action by *al-Jazeera* and other networks to use this footage aided in Hizballah’s deception of unit locations and Katyusha rocket launching sites. In addition pictures from the war zone often made their way to the front page of newspapers and internet sites from sources inside the conflict area without verification of their authenticity.

Because Hizballah tightly controlled the operating environment through their use of a variety of OPSEC activities, only the information that they wanted released usually made it out of Lebanon and into news broadcasts, websites, or morning newspapers. Hizballah even began giving guided tours of bombed out neighborhoods, stating that reporters “could only take pictures of sites approved by their Hizballah minders. Violations they were told, would be treated harshly...offending reporters would never again be allowed access to Hezbollah officials or Hezbollah-controlled areas.”¹³⁵ Some reporters recognized it for exactly what it was, “an attempt to create and control a story.”¹³⁶ Yet few journalists did anything about this and continued to tell Hizballah’s narrative to the world, regardless of whether it was true or not. The theme that resonated from these journalists, disproportionality, could be seen across the world from

¹³³ Schliefer, 6.

¹³⁴ Leggett.

¹³⁵ Kalb, 18.

¹³⁶ Kalb references a report from Anderson Cooper of CNN for this comment; a similar comment from a CNN reporter can be found on the website, Newsbusters.org, (<http://newsbusters.org/node/6552>). Kalb, 19 and Rich Noyes, “CNN’s Robertson now admits: Hezbollah ‘had control’ of his Anti-Israel Piece,” Newsbusters.org, 24 July 2006, <http://newsbusters.org/node/6552>, (accessed 4 May 2007).

Yahoo news to CNN and *al-Jazeera* to the BBC.¹³⁷ In content analysis done by Harvard's Shorenstein Center on the Press, Politics and Public Policy, the center found in repeated surveys that based on media content in various outlets both in the Middle East and in the West, Israel consistently came out labeled as the aggressor in the conflict.¹³⁸ Hizballah did this to deceive the masses about what was really happening: the kidnapping of two Israeli soldiers, the daily rocket attacks against Israeli from inside populated areas such as Qana and Hizballah's own tactics for fighting the war. Unlike other deception operations Hizballah utilized, however, this one would have mixed results.

The information age truly puts an emphasis on the individual and even the populace as the centers of gravity or target audiences in conflicts. No longer are they purely military on military battles, but the possibility exists that every single person with access to a cell phone or computer can contribute to the war effort. The effects from the summer conflict draw attention to this point. With one audience Hizballah's deception through the media proved very effective, yet with another it was exposed for what it was: a fraud. In the first case following the initiation of hostilities, Hezbollah found itself being publicly rebuffed by many Arab states to include Saudi Arabia, Jordan and Egypt; their actions in kidnapping the two IDF soldiers seen as being "reckless" and full of "adventurism" by these Arab governments.¹³⁹ This opinion, however, was not shared by these countries' populaces. As the conflict wore on and Hezbollah continued to stand up to Israeli attacks both on the ground and in the air, many of the same governments found themselves in trouble as a growing schism developed between the governments who had earlier rebuffed Hizballah and their people. In the midst of the conflict Faiza Ambah of the *Washington Post* stated that in respect to the conflict that for these Arab governments that "each

¹³⁷ Kalb, 12.

¹³⁸ For further information on this data see Kalb, 12-16.

¹³⁹ Dan Murphy, and Sameh NaGuib, "Hizbullah winning over the Arab street; Key Arab Leaders Condemn the Shiite Group, Despite its Popularity with their Citizens," *Christian Science Monitor*, 18 July 2006. <http://proquest.umi.com.libproxy.nps.navy.mil> (accessed 7 June 2007).

day the assault continues, they lose popularity and the respect of their people".¹⁴⁰ Hassan Nasrallah became a hero across countries like Egypt and Jordan as people took to the streets in support of Hezbollah, and to denounce their own governments for not supporting the terrorist group.¹⁴¹ As hostilities continued public opinion forced these same governments to reverse course on earlier statements and try to take an uneasy middle ground, while distancing themselves from both Israel and the United States. Jordan dispatched medical teams to Lebanon to help the "victims of Israeli aggression" while Saudi Arabia threatened to pull the plug on a 2002 peace plan between Arab states and Israel.¹⁴²

While the Arab states fell for Hizballah's ploy, in the United States something very different happened. If there are three names that are remembered for the summer conflict they will probably be Hizballah Leader Hassan Nasrallah, Israeli Prime Minister Ehud Olmert, and photographer Adnan Hajj. While Nasrallah and Olmert will be remembered for their roles as leaders, Hajj on the other hand will probably be remembered for something very different. For it was Adnan Hajj, working for Reuters, who took the following photographs: the first being the original and the second being doctored it and sent out across the wire services:

¹⁴⁰ Faiza Ambah, "Arab Leaders, Unlike Much of Public, Uneasy About Hezbollah," *The Washington Post*, final edition, 24 July 2006. <http://www.proquest.com.libproxy.nps.navy.mil/> (accessed 7 June 2007).

¹⁴¹ Ibid.

¹⁴² Neil MacFarquhar, "Tide of Arab Opinion Turns to Support for Hezbollah," *The New York Times*, late edition, 28 July 2006. <http://www.proquest.com.libproxy.nps.navy.mil/> (accessed 7 June 2007).



Figure 5. Original Reuters Picture¹⁴³



Figure 6. Adnan Hajj's Doctored Photograph¹⁴⁴

Shortly after the photo was published, the web blog site Little Green Footballs (<http://littlegreenfootballs.com/>) ran an entry questioning the authenticity of the

¹⁴³ Charles Johnson, "Reuters Doctoring Photos from Beirut?" *Little Green Footballs*, 5 August 2006, http://littlegreenfootballs.com/weblog/?entry=21956_Reuters_Doctoring_Photos_from_Beirut&only (accessed 4 May 2007).

¹⁴⁴ Johnson.

photo. This website, already popular for exposing the fraudulent memos that surfaced regarding President Bush's career in the Air National Guard and forced Dan Rather to resign from CBS news, again struck a coup of sorts. Within days Reuters pulled the photos and all the photos Hajj had taken and issued an apology. While it is unclear whether or not Hajj was working for Hizballah, the fact remains that he was attempting to execute his own deception operation which supported Hizballah's overall objectives. And this was not the only time this occurred during the conflict; several bloggers banded together against other reportedly doctored photographs taken in Lebanon to combat what they saw as the "lamestream media."¹⁴⁵ This incident showed a powerful new tool in combating deception in the information age. If journalists were part of new weapons systems then bloggers are now finding themselves in a role "as a club against the entire mainstream media."¹⁴⁶ In an interview with Marvin Kalb, Ravi Nessman of the Jerusalem office of the Associated Press asserts that the influence of bloggers "was unprecedented" in this conflict and that when the bloggers [in the U.S.] discovered that photographs had been doctored "the credibility of the bloggers...skyrocketed and our credibility plummeted."¹⁴⁷ Hizballah's use of deception had met a speedbump.

The use of information technology is not a traditional deception operation. But in evaluating this deception tactic, it is possible to see how the information age is producing new opportunities for deception in warfare. First of all, Hizballah took measures to simultaneously condition *different* targets' beliefs and this is now quite apparent in the responses of U.S. versus eastern audiences to the narrative told through media outlets. Specifically in the case of Middle Eastern audiences Hizballah's story influenced those governments once seen as hostile

¹⁴⁵ Paul Farhi, "Blogger Takes Aim At News Media and Makes a Direct Hit," *The Washington Post*, final edition, 9 August 2006, <http://www.proquest.com.libproxy.nps.navy.mil/> (accessed 7 June 2007).

¹⁴⁶ Farhi; For further information regarding doctored photographs from the Hizballah-Israel conflict see Kalb, *The Israeli-Hezbollah War of 2006*, and Johnson, *LittleGreenFootballs.com*.

¹⁴⁷ Kalb 33.

at the onset of hostilities to the organization to reverse their opinions. This leads to the final objective set forth by Daniel and Herbig, being able to benefit from the deception, because Hizballah profited from the target's actions through not only direct aid as was the case with Jordan, but in further isolating Israel through Saudi Arabia's actions. While in the West, the rise of bloggers had a reverse effect on the populace and in fact helped to challenge the media's role in the deception outright, something that had never been seen before in a conflict. On the issue of type of deception, this case would fall into the idea of ambiguity increasing because of the varied audiences and the global network of ideas readily available to the masses; no one was really sure what to believe.

In looking at the categories of deception, this example lies in the realm of false and planted information, because Hizballah controlled the story and what was published and often could be found working behind the scenes to ensure that it was perfect. In essence they created their own television show to be broadcast around the world via more mainstream media channels. On the final issue of sensors for this deception, it is becoming ever more apparent that in the information age and the proliferation of technology there now exists a new sensor unaddressed before in military operations, that of the individual. How the individual responds to the story and networks with others to come together and make their voice heard, is clearly a new type of sensor which challenges the existing information flow structure addressed in Chapter II, but in particular the bureaucracy of the intelligence service as the key means of influencing decisionmakers. Altogether this is a mixed case of deception because what worked to change the minds of leaders in the Middle East failed dramatically in the United States. The use of the media as a tool for deception and its challenge from networked individuals clearly shows a new instrument of war in the information age.

The following table summarizes this deception operation:

CRITERIA	EVALUATION
Three Objectives: - condition the target's beliefs? - influence the target's actions? - target's actions must benefit the deceiver?	- Through al-Manar & other new agencies on the ground, Hizballah painted its story to the world. - Arab audiences were convinced of Hizballah's actions and it reversed the attitudes of the governments.
M-type or A-type?	M-type: Hizballah sought to mislead audiences and decisionmakers from their true actions inside Lebanon.
Sensors targeted?	The media, also the individual.
9 Characteristics? (concealment, camouflage, false and planted information, ruses, displays, demonstrations, feints, lies, and insight)	False and planted information: Hizballah only showed the reporters what they wanted, the reporters broadcast the facts that they had.

Table 6. The Media Deception

G. HIJACKING THE INTERNET

The final case of deception in this study again focuses on deceit in cyber conflicts of the information age. Like the media, cyberspace is a new non-traditional area for deception, and like the media it was the work of individuals outside of state run institutions which stood up to challenge these deceptive acts.

As Israel mounted its bombing campaign against Hizballah in the summer of 2006, one of the prime targets became not only the Headquarters of *al-Manar* television, but many of the other supporting facilities such as antenna and broadcasting sites. Despite repeated attempts by the IDF to put the television network out of commission, *al-Manar* broadcasted continuously from hidden locations and even thwarted being hacked into by the elements from the IDF's intelligence corps.¹⁴⁸ Ultimately, the IDF's hacking campaign only affected the

¹⁴⁸ Murphy.

internal Lebanese broadcasts of *al-Manar*, but the rest of the Arab street maintained an uninterrupted satellite feed for the duration of the war.

This cyber war between IDF hackers and *al-Manar* pushed the conflict into a new arena. Hezbollah turned to hiding and hijacking in the internet in an attempt to restore its message of resistance. Hilary Hylton of *Time* researched this aspect of Hizballah's information plan and found that hackers from the militant Lebanese group searched the internet for vulnerable sites to hijack and then communicate with one another.¹⁴⁹ She states "Hizballah uses these Web sites to run recruitment videos and post bank account numbers where supporters can donate funds" and that these communications portals are "critical as Hizballah tries to get its global message out to the world".¹⁵⁰ One hijacking occurred on a South Texas cable company:

Al-Manar...linked to the small cable company's IP address, which can be thought of, in simple terms, as a telephone number. Hizballah essentially added an extension on that telephone line allowing their traffic to flow. Hizballah then gets the word out through e-mail and blogs that it can be found at that IP address and the hijack is complete. If the hijack is not detected, the IP address can be linked to a new domain name and that opens up the site to anyone who might search online for *al-Manar* content.¹⁵¹

Since in the past many companies would not realize if this was occurring, and groups such as Hizballah could get away with it, this tactic proved very useful for terrorists or insurgent groups to continue to get their message out, even if it was impossible to do so from their home countries.

While instances of cyber deception similar to this had worked in the past, this time it failed due to the work of networked groups like the Society for Internet Research, "an informal consortium of self-described 'freelance counterterrorists'

¹⁴⁹ Hilary Hylton, "How Hizballah Hijacks the Internet," *Time*, 8 August 2006, <http://www.time.com/time/world/printout/0,8816,1224273,00.html>, (accessed 14 November 2006).

¹⁵⁰ Ibid.

¹⁵¹ Hylton.

who sit in home offices and dens tracking jihadist activity on the Internet.”¹⁵² It was this group that tracked Hizballah’s web activities to the Texas cable company and notified U.S. authorities who in turn shut the IP address down. As a result Hizballah’s *al-Manar* was forced to look for other IP’s until its own could be re-established after the war.

While this case of cyber-hijacking is not as strong a deception case as the previous examples, it still deserves mention because it shows the lengths that groups like Hizballah will go to in an effort to put out their message. In regard to deception type criteria, this action does not meet the idea of conditioning a target’s beliefs; rather it is simply an act designed for the deceiver to hide within the target and maintain some level of cover and concealment. Furthermore, there is no influence to the target’s actions; however, by having an open IP address, the deceiver is able to benefit from the target’s actions. As mentioned this particular case is best considered in the category of concealment or camouflage, yet does not fit into either of the two types of deception identified, neither ambiguity increasing nor misleading. Therefore this case provides the possibility for a new type of deception, one in which the deceiver attempts to purely conceal themselves.

Regarding sensors, however, cyber hijacking primarily rests on the ability of host to leave backdoors open to its systems for these hacking bodies to attach themselves to. Finally, the case of cyber hijacking reinforces the power of the individual or networks to counter this and similar threats in cyberspace. While it is seemingly a weak form of deception in the realm of cyber warfare, the fact that networks like the Society for Internet Research are patrolling the internet on their own, without government involvement, shows another prime example of how the information age has empowered what traditionally have been considered non-combatants to take matters into their own and counter deception from the comfort of their own homes. The following table summarizes this case:

¹⁵² Hylton.

CRITERIA	EVALUATION
Three Objectives: - condition the target's beliefs? - influence the target's actions? - target's actions must benefit the deceiver?	- Hizballah successfully hijacked unknowing IP addresses in cyberspace for its <i>al-Manar</i> websites. - Networked groups around the US looked for and found these hijacked sites.
Sensors targeted?	The only sensors targeted were unknowing ISPs who had no idea what Hizballah was doing.
Type: M-type or A-type?	Neither type fits into this criteria for deception because it success lies in staying hidden.
9 Characteristics? (concealment, camouflage, false and planted information, ruses, displays, demonstrations, feints, lies, and insight)	Concealment: Hizballah hid from plain view and known IP addresses after Israel destroyed many of their support facilities in Lebanon.

Table 7. Hijacking the Internet

This is another example of the interaction between information activities. The use of the internet covers over into the realm of computer network operations and through this example it is apparent that the concept of deception still plays out in cyberspace today.

H. CONCLUSION

The preceding paragraphs present several cases of deception from the Israel-Hizballah conflict along with supporting information on how Hizballah managed to deny Israel access to many of their traditional sources of information, thus allowing Hizballah to dominate Israel in ways unforeseen only a short time ago. Two of the studies showed how traditional forms of deception are still very applicable to modern warfare, while at least one of the last two cases shows how using the media is transforming deception in the information age. In the last instance of internet hijacking shows how groups like Hizballah will hide in

cyberspace, utilizing unknowing targets to further their objectives. Despite of this example, there are still key lessons to be learned and applied regarding deception in these types of conflict.

V. CONCLUSION

Oh what a tangled web we weave

When first we practice to deceive!

-Sir Walter Scott
Marmion. Canto vi. Stanza 17

A. RE-EXAMINING DECEPTION IN THE INFORMATION AGE

This paper has argued that Hizballah used deception tactics very effectively in their defense of southern Lebanon during the 2006 Summer War against Israel; this use of deception significantly offset many of Israel's hard power advantages. Hizballah's use of deception not only worked on a tactical level, but operationally as well. Moreover, Hizballah used new forms of information technology based deception relevant in the information age.

Three of the four cases explored and evaluated met the criteria of deception, but all show at least elements of deception. And while two of the cases, the bunkers and the EW bluff, are more traditional forms of deception, the latter cases of the media and hijacking the internet show the complexities of deception in the present day. The following table summarizes this data:

ACT	LEVEL OF WARFARE	DESCRIPTION
Fake Bunkers	Tactical	Hizballah built fake bunkers to confuse Israeli intelligence about the actual location of their bunkers
Electronic Warfare Bluff	Tactical/Operational	Hizballah bluffed about being able to listen into Israeli secure frequency hopping radio systems.
The Media	Operational	Hizballah used the media as their tool to conceal their use of civilian areas to launch rockets.
Hijacking the internet	Tactical/Operational	Hizballah "hid" on internet service providers in the US to maintain its capability to broadcast via broadband.

Table 8. Summary of Deception Activities

Based on this information regarding the press and the bloggers, a further question may be raised regarding deception and information flow.

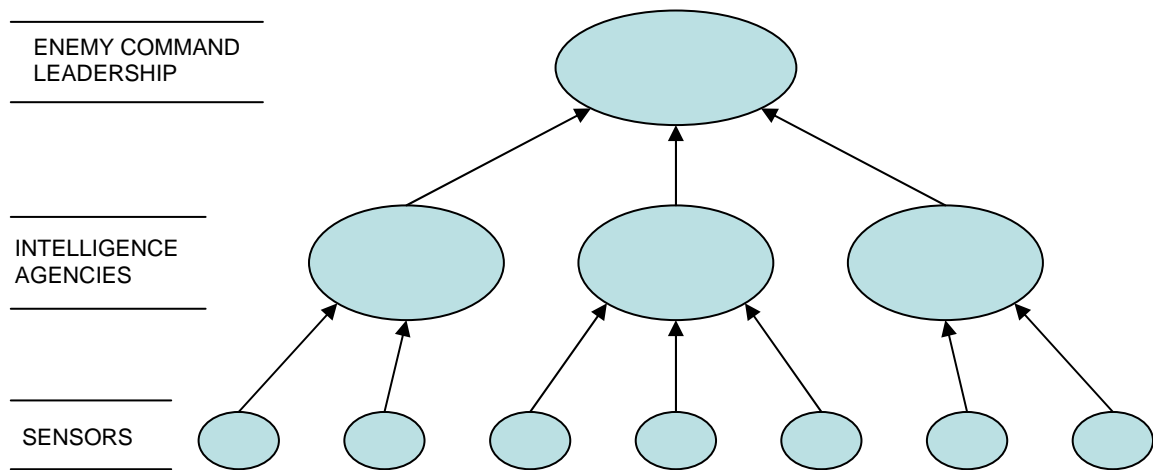

Figure 7. Deception Information Flow to Target

Having tested the above presented model in Chapter II based on the summer conflict, it appears that the information age has changed the information flow model somewhat. Specifically, the intelligence services are no longer the only stepping stone in which information from sensors can be evaluated and forwarded to the ultimate target, the opponent's leadership. Now individuals can influence the adversary through access to information technologies such as the Internet and home computers. Furthermore, the individual can use technology to network with others to counter deceptive acts by an opponent. Individuals can also directly affect the deceiver's message and take that to the leadership, as in the case of Arab states such as Jordan and Saudi Arabia. Finally, adversarial decisionmakers' actions may differ to the deception based on how these networks and sensors react to the deception.

With these thoughts in mind, a newer information flow hierarchy model for the information age might look like this:

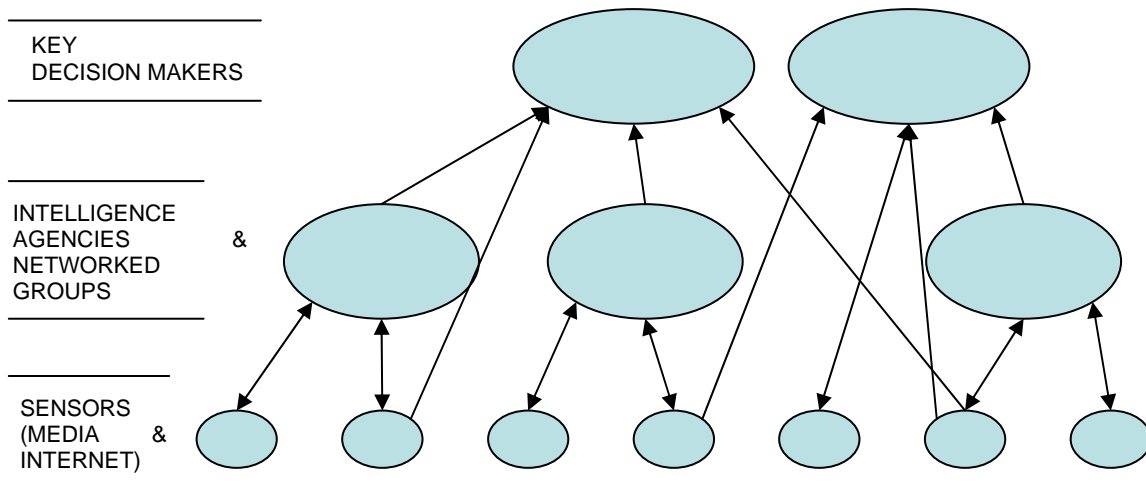

Figure 8. New Model for Deception Information Flow Hierarchy

The new model captures two changes in particular. First, the power of information to be spread quickly and independently can affect the enemy’s leadership. A deception operation, using media sources, like Hizballah’s EW bluff, has the capability to reach top commanders quickly, often bypassing intelligence services. Second, as noted by the reverse arrows, individuals and networked groups now have the potential to challenge many sensors sending information out and to counter it, as witnessed in the use of the bloggers and other internet groups in challenging the “lamestream media,” as well as efforts by Hizballah to hide on the web. Marvin Kalb addresses this idea of the media & bloggers when he writes:

“Broadcast via broadband,” in the context of asymmetrical warfare, involves an unimaginable convergence of hi-tech gadgetry and populist journalism, enriched by millions of bloggers offering their opinions, influencing policy and public opinion, questions decisions by officials, doubting the credibility of journalists, presenting commentaries as well as photographic evidence—in a nutshell, scrambling opinion with fact and affecting the course and conduct of a war.¹⁵³

¹⁵³ Kalb, 24.

In conclusion the information age has created new checks and balances to the deception game. These factors must be taken into account in the planning of deception operations in the future.

B. LINKAGES BETWEEN INFORMATION OPERATION CAPABILITIES

As shown throughout this paper, there are linkages between all of the information activities identified in Chapter II. Hizballah has proven that these information operations capabilities go hand in hand during major combat operations and thus validating U.S. joint doctrine. Deception cannot exist apart from these other information capabilities. This should serve as evidence that these capabilities must always be simultaneously planned and executed as part of the larger operation.

In the forthcoming new release of the U.S. Army's Field Manual 3-0 *Operations*, the manual divides the existing tenets of information operations (CNO, PSYOP, Deception, OPSEC, and EW) into subgroups isolated from one another. In particular "information engagement" now only includes PSYOP, Public Affairs (PA), and Military Support to Public Diplomacy (MSPD), while EW, CNO, OPSEC and Deception fall into different categories with different staff sections responsible for planning each separately. The Army should re-examine its approach to information operations using this study of Hizballah's techniques and procedures as a guide.

C. AREAS FOR FURTHER RESEARCH

Hizballah's use of deception in the July-August 2006 conflict suggests several other areas of research. Among these areas:

1. Application of These Deception Criteria to Other information Age Conflicts

Applying the qualifying criteria listed in Chapter IV to other contemporary conflicts would greatly enhance a study of deception in the present day. In

particular conflicts such as the one between the U.S. and Al-Qaeda, Israel and the Palestinians or the ongoing conflict in Iraq could all serve as interesting cases to explore if there is deception occurring and if so, how does it apply to the criteria listed here. In particular the idea of whether information technology is as present in other conflicts as it was with Hizballah could be addressed. Another area might look at the information flow hierarchy and how it functioned during a similar conflict.

2. Examination of the Relationship Between Psychological Operations and Deception

Chapter II addressed the issue of deception and its linkages to other information related capabilities. This is another area explored by further research. In particular more research is needed between PSYOP and deception and operations psychological waged (i.e. rocket and bombing attacks aimed at civilian populace) to see where such area overlap and how they relate to one another.

3. Deception in Computer Network Operations

While this paper only scratched the surface on implications of deception in regards to computer network operations (CNO), a more indepth study should be undertaken to examine how such activities could occur and their implications for cyberwarfare in the 21st Century. Based on this research, analysts could construct a separate model for deception and CNO. Hizballah's use of the internet could serve as an excellent example of such activity.

4. The Role of Non-Combatants in Information Age Conflicts

The role of the media in war is not new. This thesis, however, presents some new avenues of research on the role of the media and other networked groups in deception. Andrew Exum points out in a recent article that "all media

are not created alike.”¹⁵⁴ This war showed that the media, except in the case of *al-Manar*, unknowingly became a tool of Hizballah and therefore part of the deception plan. This raises an important issue then that Exum also brings up, “For while Protocol I (Article 79) of the Geneva Conventions makes clear that journalists are to be treated as civilians, any journalist who engages in military actions forfeits his or her status as a noncombatant.”¹⁵⁵ Re-examining the rights of the media in warfare based on Hizballah’s use of them, should be studied. This discussion should also be extended to explore those other networks such as the bloggers and internet groups who mobilize and take action on their own. In addition a possible area of research may involve the use of bloggers for deception and the possibilities of such activities.

D. CONCLUSION

Regardless of how Israel may portray its accomplishments during the recent conflict including the destruction of Hizballah’s missile capabilities and reducing the organization’s ability to wage war, Hizballah still managed to spin a story of success: an IO campaign ripe with deception. This study of Hizballah demonstrates that deception in the current operational and tactical environment still plays a key role in helping to achieve one’s objectives. Deception is no longer inflatable tanks and fake airplanes; it has evolved to include information technologies of the 20th century. Delivery of the deception signal to sensors, and that signal’s interpretation by not just traditional agencies but by networked individuals, has become as important as bullets fired at the enemy. Hizballah realized the importance of the concept and employed it fervently in this conflict.

The final impact of this conflict remains to be seen. Power plays in Lebanon continue as Hassan Nasrallah and Hizballah vie for further representation in the government, aided by masses of Lebanese from all sects

¹⁵⁴ Andrew Exum, “Illegal Attack or Legitimate Target? Al-Manar, International Law and the Israeli War in Lebanon,” *Arab Media & Society*, February 2007, <http://www.arabmediasociety.org/?article=20> (accessed 5 May 2007).

¹⁵⁵ Ibid.

marching behind them. While many point to Israel's decisionmaking as the reason it failed to win this conflict, Hizballah's information campaign aided and shaped the Israel's decision process. This study should serve as an example of how deception can be employed to shape the outcomes of war. If anyone thinks that these tools are only limited to Lebanon and Israel, they are sadly mistaken. The *New York Times* reports that as recently as the summer of 2006 in Iraq "Hezbollah had been training members of the Mahdi Army, the Iraqi Shiite militia led by Moktada al-Sadr".¹⁵⁶ Armies around the world must be aware of these deception tactics and methods less they face the same fate as Israel; the clock is ticking.

¹⁵⁶ Michael Gordon and Dexter Filkins, "Hezbollah Helps Iraq Shiite Army, U.S. Official Says," *The New York Times*, 28 November 2006, late edition, <http://www.proquest.com.libproxy.nps.navy.mil/> (accessed 7 June 2007).

THIS PAGE INTENTIONALLY LEFT BLANK

LIST OF REFERENCES

- Ali, Abdullah Yusuf. *The Meaning of the Holy Qur'an*. Baltimore MD: Amana Publications, 1989.
- Ambah, Faiza. "Arab Leaders, Unlike Much of Public, Uneasy About Hezbollah." *The Washington Post*, final edition, 24 July 2006.
<http://www.proquest.com.libproxy.nps.navy.mil/> (accessed 7 June 2007).
- Bazzi, Mohamad. "Hezbollah Cracked the Code; Technology likely supplied by Iran allowed guerillas to stop Israeli tank assaults." *Newsday.com*, 18 September 2006. <http://www.newsday.com/news/nationworld/world/ny-wocode184896831sep18,0,3091818.story?coll=ny-worldnews-print> (accessed 21 November 2006).
- Blanford, Nicholas. "Deconstructing Hizbullah's Surprise Military Prowess." *Jane's Intelligence Review*, 1 November 2006.
<http://www2.janes.com.libproxy.nps.navy.mil/> (accessed 7 June 2007).
- . "Hizbullah's Resilience built on years of homework; Meticulous planning and a thorough understanding of Israeli military doctrine both play into its success." *Christian Science Monitor*, 11 August 2006.
<http://proquest.umi.com.libproxy.nps.navy.mil> (accessed 7 June 2007).
- Carr, Caleb ed. *The Book of War*. New York: Modern Library Books, 2000.
- Cody, Edward and Molly Moore. "'The Best Guerilla Force in the World'; Analysts Attribute Hezbollah's Resilience to Zeal, Secrecy and Iranian Funding." *The Washington Post*, 14 August 2006, final edition.
<http://proquest.umi.com.libproxy.nps.navy.mil> (accessed 7 June 2007).
- Cordesman, Anthony H. "Preliminary "Lessons" of the Israeli-Hezbollah War." *Center for Strategic and International Studies*, 17 August 2006.
http://www.csis.org/media/csis/pubs/060817_isr_hez_lessons.pdf (accessed 21 November 2006).
- Ciezdalo, Annia. "Beirut Dispatch: Sheik Up." *The New Republic*, 7 August 2006.
<http://web.ebscohost.com/ehost/pdf?vid=2&hid=122&sid=0a67bf8e-7e13-4a65-9489-459441a86676%40sessionmgr108>).
- Cobban, Helena. *The Making of Modern Lebanon*. Boulder CO: Westview Press, 1985.

- Crooke, Alistair and Mark Perry. "How Hezbollah Defeated Israel: Part 1: Winning the Intelligence War." *Online Asia Times*, 13 October 2006. http://www.atimes.com/atimes/Middle_East/HJ12Ak01.html. (accessed 15 November 2006).
- . "How Hezbollah Defeated Israel: Part 2: Winning the Ground War." *Online Asia Times*, 13 October 2006. http://www.atimes.com/atimes/Middle_East/HJ13Ak01.html. (accessed 15 November 2006).
- Daniel, Donald C. and Katherine Herbig. "Propositions of Military Deception." in *Strategic Military Deception*, ed. Donald C. Daniel and Katherine L. Herbig. New York: Pergamon Press, 1982.
- Doniach, N.S. ed. *The Oxford English-Arabic Dictionary*. Oxford, England: Clarendon Press, 1972.
- Dunnigan, James and Albert Nofi. "Deception Explained, Described, and Revealed." in *Victory and Deceit: Dirty Tricks in War*. New York: W. Morrow, 1995.
- Exum, Andrew. "Illegal Attack or Legitimate Target? Al-Manar, International Law and the Israeli War in Lebanon." *Arab Media & Society*, February 2007. <http://www.arabmediasociety.org/?article=20> (accessed 5 May 2007).
- Farhi, Paul. "Blogger Takes Aim At News Media and Makes a Direct Hit." *The Washington Post*, final edition, 9 August 2006. <http://www.proquest.com.libproxy.nps.navy.mil/> (accessed 7 June 2007).
- Fowler, Charles and Robert Nesbit. "Tactical Deception in Air-Land Warfare." *Journal of Electronic Defense*, June 95.
- Fulghum, David. "Doubt as a Weapon." *Aviation Week & Space Technology*, 27 November 2006.
- Gordon, Michael and Dexter Filkins. "Hezbollah Helps Iraq Shiite Army, U.S. Official Says." *New York Times*, 28 November 2006, late edition. <http://proquest.umi.com.libproxy.nps.navy.mil> (accessed 7 June 2007).
- Hamzeh, Nizar A. "Lebanon's Hizbullah: from Islamic Revolution to Parliamentary Accommodation." American University of Beirut, 1993. <http://almashriq.hiof.no/ddc/projects/pspa/hamzeh2.html>. (accessed 16 November 2006).
- Handel, Michael. "Intelligence and Deception." in *Military Deception and Strategic Surprise*, ed. John Gooch and Amos Perlmutter. London: Frank Cass & Co. Ltd, 1982.

Harik, Judith Palmer. *Hezbollah: The Changing Face of Terrorism*. New York: I.B. Tauris & Co, Ltd, 2004.

----- . "Between Islam and the System: Sources and Implications of Popular Support for Lebanon's Hizballah." *Journal of Conflict Resolution*, 40 (1996): 41-67.

Harb, Mona and Reinoud Leenders. "Know thy enemy: Hizbullaha, 'terrorism' and the politics of perception." *Third World Quarterly* 26 (2005): 173-197.

Heuer, Richards J. "Cognitive Factors in Deception and Counterdeception." in *Strategic Military Deception*, ed. Donald C. Daniel and Katherine L. Herbig. New York: Pergamon Press, 1982.

Hoffman, Frank G. "Mind Maneuvers." *Armed Forces Journal*, April 2007. <http://www.armedforcesjournal.com/2007/04/2550166/> (accessed 24 April 2007).

Holt, Thaddeus. *The Deceivers*. New York: Scribner, 2004.

Hylton, Hilary. "How Hizballah Hijacks the Internet." *Time*, 8 August 2006. <http://www.time.com/time/world/printout/0,8816,1224273,00.html>. (accessed 14 November 2006).

Jajko, Walter. "Deception: Appeal for Acceptance; Discourse on Doctrine; Preface to Planning." *Comparative Strategy*, 21: 351-363, 2002.

Johnson, Charles. "Reuters Doctoring Photos from Beirut?" *Little Green Footballs*, 5 August 2006. http://littlegreenfootballs.com/weblog/?entry=21956_Reuters_Doctoring_Photos_from_Beirut&only (accessed 4 May 2007).

Jorisch, Avi. *Beacon of Hatred: Inside Hezbollah's Al-Manar Television*, Washington: Washington Institute for Near East Policy, 2004.

Kalb, Marvin. "The Israeli-Hezbollah War of 2006: The Media As A Weapon in Asymmetrical Conflict." *Joan Shorenstein Center on the Press, Politics and Public Policy*, February 2007. http://www.ksg.harvard.edu/presspol/research_publications/papers/research_papers/R29.pdf (accessed 24 April 2007).

Levitt, Matthew. "Shutting Hizbullaha's 'Construction Jihad.'" *Policy Watch #1202, Washington Institute for Near East Policy*, 20 February 2007. <http://www.washingtoninstitute.org/templateC05.php?CID=2571> (accessed 23 February 2007).

- MacFarquhar, Neil. "Tide of Arab Opinion Turns to Support for Hezbollah." *The New York Times*, late edition, 28 July 2006.
<http://www.proquest.com.libproxy.nps.navy.mil/> (accessed 7 June 2007).
- Mahnaimi, Uzi. "Humbling of the Supertroops Shatters Israeli Army Morale." *The Sunday Times*, 27 August 2006.
http://www.timesonline.co.uk/article/0,,2089-2330624_1,00.html (accessed 20 November 2006).
- Makovsky, David and Jeffrey White. "Lessons and Implications of the Israel-Hezbollah War: a Preliminary Assessment." *The Washington Institute for Near East Policy*, October 2006, Policy Focus #60.
<http://www.washingtoninstitute.org/pubPDFs/PolicyFocus60.pdf> (accessed 29 November 2006).
- Murphy, Dan, and Sameh NaGuib. "Hizbullah winning over the Arab street; Key Arab Leaders Condemn the Shiite Group, Despite its Popularity with their Citizens." *Christian Science Monitor*, 18 July 2006.
<http://proquest.umi.com.libproxy.nps.navy.mil> (accessed 7 June 2007).
- Nasrallah, Hassan. *Address of General Secretary of Hizballah*. 14 July 2006, translated by Eric Mueller.
<http://electronicintifada.net/bytopic/historicalspeeches/447.shtml>
 (accessed 1 May 2007).
- Norton, Augustus Richard. *Amal and the Shi'a: Struggle for the Soul of Lebanon*. Austin TX: University of Texas Press, 1987.
- *Hezbollah*. Princeton NJ: Princeton University Press, 2007.
- "Hezbollah: From Radicalism to Pragmatism." *Middle East Policy Journal*, V, no. 4 (January 1998).
http://www.mepc.org/journal_vol5/9801_norton.asp (accessed 3 December 2006).
- Noyes, Rich. "CNN's Robertson now admits: Hezbollah 'had control' of his Anti-Israel Piece." *Newsbusters.org*, 24 July 2006.
<http://newsbusters.org/node/6552>, (accessed 4 May 2007).
- Packer, George. "Knowing the Enemy." *New Yorker*, 18 December 2006.
<http://proquest.umi.com.libproxy.nps.navy.mil> (accessed 7 June 2007).
- Prusher, Ilene. "At War, Israeli Reservists wield new weapon: opinion polls." *Christian Science Monitor*, 16 August 2006, all edition.
<http://www.csmonitor.com/2006/0816/p10s01-wome.html> (accessed 28 November 2006).

- Ranstorp, Magnus. "The Strategy and Tactics of Hizballah's Current 'Lebanonization Process.'" *Mediterranean Politics*, 3 (1998): 103-134.
- Robinson, Phil and Lawrence Lasker et al. *Sneakers* [Motion picture]. Hollywood, CA: Universal. 1992.
- Schleifer, Ron. "Psychological Operations: A New Variation of an Age Old Art: Hezbollah versus Israel." *Studies in Conflict and Terrorism*, 29 (2006): 1-19.
- Shadid, Anthony. "Inside Hezbollah, Big Miscalculations." *The Washington Post*, 8 October 2006, final edition. <http://www.washingtonpost.com/wp-dyn/content/article/2006/10/07/AR2006100701054.html> (accessed 13 December 2006).
- Shapira, Shimon. "The Origins of Hizballah." *The Jerusalem Quarterly*, 46 (1988): 115-130.
- Shulsky, Abram. "Elements of Strategic Denial and Deception." ed. Roy Godson and James J. Wirtz. in *Strategic Denial and Deception*. New Brunswick, NJ: Transaction Publishers, 2006.
- Shultz, Richard and Roy Godson. "Intelligence Dominance." *The Weekly Standard*, 31 July 2006.
- U.S. Department of Defense. *Joint Publication 3-13: Information Operations*. Washington D.C.: Government Printing Office, 13 February 2006.

THIS PAGE INTENTIONALLY LEFT BLANK

INITIAL DISTRIBUTION LIST

1. Defense Technical Information Center
Ft. Belvoir, Virginia
2. Dudley Knox Library
Naval Postgraduate School
Monterey, California
3. Dr. Tim Thomas
Foreign Military Studies Office
Fort Leavenworth, Kansas
4. COL John Davis
1st Information Operations Command (Land)
Fort Belvoir, Virginia