

**SHELL PLATE DEFINITION
GUIDE
FOR
SHIP DESIGNERS**

Prepared by

Thomas Lamb
Director of Engineering
Textron Marine Systems
A Division of Textron, Inc.

May 1994

for

THE NATIONAL SHIPBUILDING RESEARCH PROGRAM
SP-4 (DESIGN/PRODUCTION INTEGRATION) Panel

of

The Society of Naval Architects and Marine Engineers
Ship Production Committee

Report Documentation Page

Form Approved
OMB No. 0704-0188

Public reporting burden for the collection of information is estimated to average 1 hour per response, including the time for reviewing instructions, searching existing data sources, gathering and maintaining the data needed, and completing and reviewing the collection of information. Send comments regarding this burden estimate or any other aspect of this collection of information, including suggestions for reducing this burden, to Washington Headquarters Services, Directorate for Information Operations and Reports, 1215 Jefferson Davis Highway, Suite 1204, Arlington VA 22202-4302. Respondents should be aware that notwithstanding any other provision of law, no person shall be subject to a penalty for failing to comply with a collection of information if it does not display a currently valid OMB control number.

1. REPORT DATE MAY 1994		2. REPORT TYPE N/A		3. DATES COVERED -	
4. TITLE AND SUBTITLE Shell Plate Definition Guide for Ship Designers				5a. CONTRACT NUMBER	
				5b. GRANT NUMBER	
				5c. PROGRAM ELEMENT NUMBER	
6. AUTHOR(S)				5d. PROJECT NUMBER	
				5e. TASK NUMBER	
				5f. WORK UNIT NUMBER	
7. PERFORMING ORGANIZATION NAME(S) AND ADDRESS(ES) Naval Surface Warfare Center CD Code 2230 - Design Integration Tower Bldg 192 Room 128 9500 MacArthur Blvd Bethesda, MD 20817-5700				8. PERFORMING ORGANIZATION REPORT NUMBER	
9. SPONSORING/MONITORING AGENCY NAME(S) AND ADDRESS(ES)				10. SPONSOR/MONITOR'S ACRONYM(S)	
				11. SPONSOR/MONITOR'S REPORT NUMBER(S)	
12. DISTRIBUTION/AVAILABILITY STATEMENT Approved for public release, distribution unlimited					
13. SUPPLEMENTARY NOTES					
14. ABSTRACT					
15. SUBJECT TERMS					
16. SECURITY CLASSIFICATION OF:			17. LIMITATION OF ABSTRACT SAR	18. NUMBER OF PAGES 44	19a. NAME OF RESPONSIBLE PERSON
a. REPORT unclassified	b. ABSTRACT unclassified	c. THIS PAGE unclassified			

TABLE OF CONTENTS

	Page
1.0 INTRODUCTION.....	1
2.0 BACKGROUND.....	2
3.0 CURVATURE	
3.1 Curve Curvature.....	6
3.2 Surface Curvature.....	6
3.3 Curvature Indicators.....	7
4.0 LINES DEVELOPMENT	
4.1 Use of surface curvature measurements to avoid difficult plates.....	9
4.2 Upper Stem.....	12
4.3 Lower Stem.....	12
4.4 Bulbous Bows.....	16
4.5 Upper Stern.....	16
4.6 Lower Stern - Single Screw.....	16
4.7 Lower Stern - Twin Screw.....	23
4.8 Chines.....	23
5.0 SHELL PLATE DEFINITION	
5.1 The Start.....	29
5.2 Shell Plate Selection.....	29
5.3 Checking Shell Plates for Development and Forming Acceptability.....	35
5.4 Addition of Butts to Aid Development and Forming.....	38
6.0 CLOSURE.....	41

1.0 INTRODUCTION

This guide has been prepared as part of the performance of a project to help put shell plate development problems in their correct perspective and to attempt to determine if the goal of cutting all shell plates neat is reasonable. The study was undertaken on behalf of the SP-4 (DESIGN/PRODUCTION INTEGRATION) Panel of the National Shipbuilding Research Program.

It was performed in two phases.

Phase I objectives were:

- . To obtain the participation of existing shipbuilding and aerospace computer aided lofting system developer/users to discuss:
 - Shell development problems
 - The methods they use to develop shell plate and handle the problems
 - Any stipulated limitations in application
- . To report on the findings of the above discussion
 - . To select five (5) shell plates representative of the “difficult” type as test cases to be developed by the computer aided lofting system participants, in Phase II of the study.

Phase II objectives were:

- . The development of the 5 test cases by each of the participating CAL subcontractors
- . Comparison of the developments and presentation of the findings
 - . Preparation of a guideline for ship designers to use for hull shaping and shell plate selection that assists in their accurate fabrication

The LIMITATIONS OF COMPUTERIZED LOFTING FOR SHELL PLATE DEVELOPMENT report (NSRP 0409) covers both phases. This SHELL DEVELOPMENT GUIDE FOR SHIP DESIGNERS achieves the final project objective.

2.0 BACKGROUND

A ship is generally designed by a number of people. The naval architect will decide the ship's dimensions, hull shape and general configuration. The hull planner will decide the block breakdown. The structural designer will define the shell plates. Each designer or planner impacts how acceptable, that is how correct, the flat plate development of the curved shell plates will be and how easy they can be formed and erected. It is probable that they are not even aware of this.

The development of low resistance and efficient propulsion lines is a highly specialized field that is usually performed by naval architects and hydrodynamicists with very little ship engineering and no production experience. While it is not proposed that producibility considerations should be allowed to overrule the technical considerations, it is being proposed that the lines developers as well as the designers who define the shell plates, should obtain a better understanding of the impact their decisions have on the difficulty of constructing a ship. With this knowledge they would be able to incorporate producibility improvement concepts that have a high cost reduction and a small adverse impact on the operational efficiency of the ship.

It is also probable that the hull planner also does not know the impact of his decisions on the difficulty of developing, forming and erecting the curved shell plates.

It should be remembered that it is mathematically impossible to develop an exact flat pattern for a plate containing double curvature. All flat plate development of double curvature plates is, at best, a definition of the plate outlines that, when formed to the required surface shape, will be a close approximation to the shaped shell plates.

Ship designers have been designing ships for along time and it seems that it is only recently that the problems have been reported. Why is this? It is because of a number of changes in the way that ships are constructed that require greater accuracy in assembly and fit up. This matter is covered in detail in the study report and can be reviewed therein.

To help understand the problem, the plating of a sphere using neat cut plates from geometrically developed patterns and sets to control manual forming, can be used as an example. The extent of the manual forming and the resulting fit up of each plate to the other plates will depend on the number of plates used. Figure 2.1 clearly shows this. All plates have double curvature. With four segmental plates each plate would require extensive work to form it to its required shape. Also the fit up accuracy would be poor. That is the fit of each plate to its adjacent plates would have gaps. As the number of plates increase, and therefore become smaller, the extent of manual forming work decreases and the accuracy of fit up improves.

In the past, the traditional loftsmen understood this very well and learned to define shell plates with as "natural" a fit to the hull surface as possible by straking to suit the shape. With their trained eyes they could "feel" where butts were required to assure acceptable developable and formable plates. They also took care of the full or 1:10 scale fairing of the lines and eliminated any unfairness in the lines developed by the designer without any interface with them.

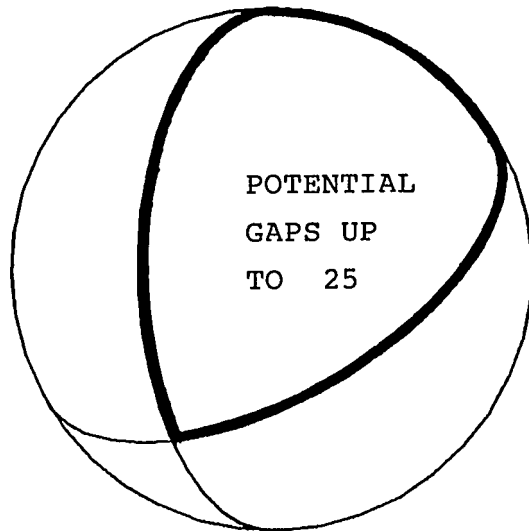

3000 DIAMETER SPHERE WITH
4 SEGMENTAL PLATES

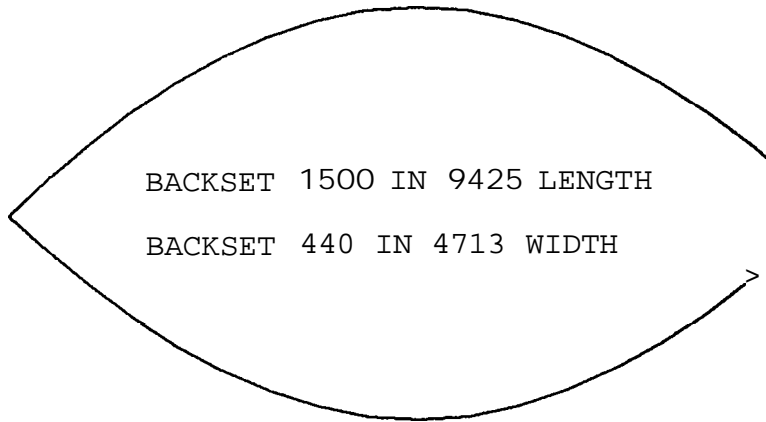

DEVELOPED SHAPE

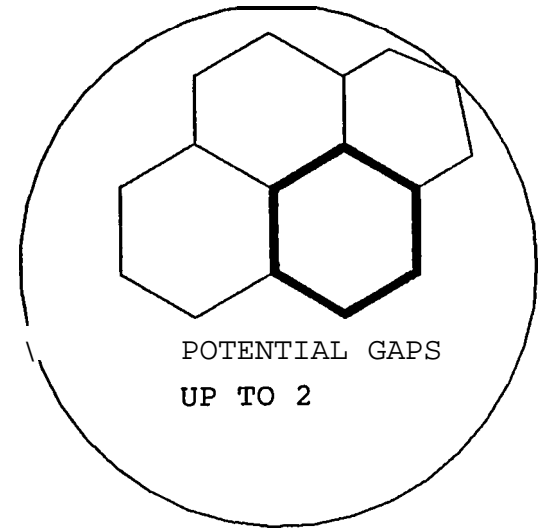

3000 DIAMETER SPHERE WITH
20 HEXAGONAL PLATES

BACKSET 20 IN 500

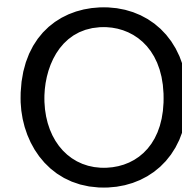

DEVELOPED SHAPE

FIGURE 2.1 - EFFECT OF PLATE SIZE ON DEVELOPMENT AND FORMING

Unfortunately this skill is being lost as traditionally trained loftsmen retire and the need for them is obscured by the application of computer aided lofting (CAL). Also, as the lofting output became a fall out from the application of shipbuilding CAD based design, both the lofting knowledge and experience has been lost. There was no apparent reason to put a CAL user through a traditional lofting apprenticeship, but without it the lofting knowledge and skills cannot be retained. The skill to look at a body plan on the scribe board, paper or work station and select butts and seams for ease of lofting and forming of shell plates is all but gone.

While this was occurring, another major shipbuilding change was also resulting in shell plate problems. This change was the introduction of modular or block structure assembly and erection. For ease of assembly, vertical and transverse butts and horizontal and fore and aft seams were being selected. These resulted in plates with much greater double curvature and significant twist for the shaped portions of a ship's hull. This makes the flat plate developments for such plates even less correct than the traditional "naturally" straked shell plates. This can be seen from Figure 2.2 which shows, in body plan view, the difference between natural and block straking.

It has already been stated that these problems cannot be resolved mathematically. Therefore the shipbuilder desired improvements must come from the effective application of design for production approaches and a complete understanding of their limitations. If the block approach with vertical butts and horizontal seams is being used, then it should be accepted that stock will be required on certain butts and seams to provide allowance for fit up. Having stated this, it is still both possible and necessary for ship designers and planners to jointly use all technically acceptable approaches to reduce the shell plate development, forming and erection problems.

It is acknowledged that mathematically developable surfaces are utilized, in conjunction with chines, on small ships. However, they have not been incorporated into large ship hull shaping.

The purpose of this guide is to help ship designers and planners apply these approaches. This will be accomplished by describing the problems and some ideas on how to avoid them or at least reduce their adverse impact.

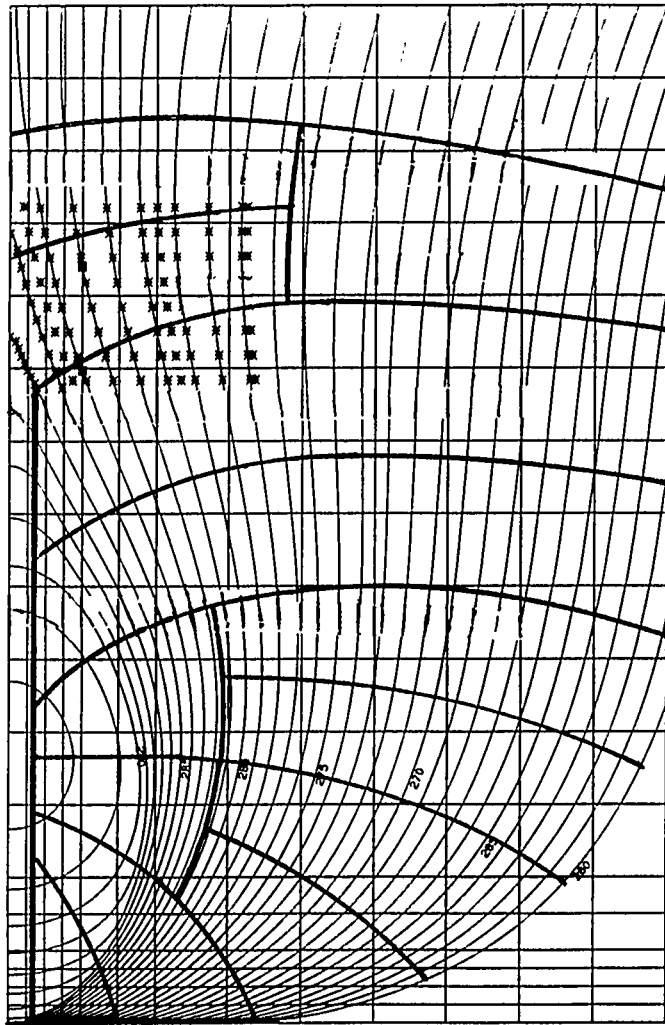

TRADITIONAL

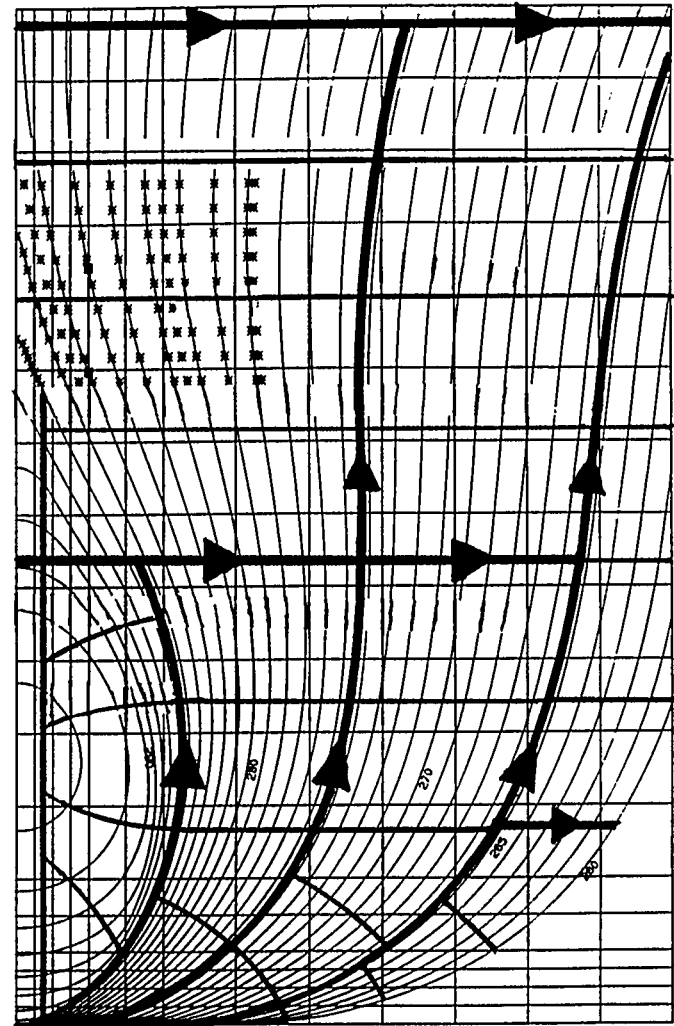

TO SUIT BLOCK CONSTRUCTION

FIGURE 2.2 - SHELL PLATE STRAKING

3.0 CURVATURE

What is curvature? Although as a technical term it does not suffer from the problem of many different and often conflating definitions, like many other technical terms, it does suffer from a general lack of interest. Only those who need to use it take the time to understand it. Therefore, a brief description of curvature and its application to ships is necessary. The following description is based on the AutoShip Users Manual.

3.1 Curve Curvature

For any point on a curve, except where it is a straight line, it is possible to find one, and only one, circle of finite radius which is tangent to the curve at that point. This means that the circle and curve touch and have the same slope and rate of change of slope where they touch. A line drawn from the circle center to the tangent point lies in the direction of the principle normal to the curve. The radius of the circle is the radius of curvature at that point and its inverse is the curvature proper.

3.2 Surface Curvature

Surface curvature is more complex. First, imagine a plane tangent to the surface at the point of interest, called p . Now imagine a plane which is perpendicular to the first plane and passes through p . The intersection of this plane and the surface defines a curve, and we can find a tangent circle to this curve at p . At p there is only one tangent plane, but there are an infinite number of perpendicular planes and the curves they define.

The two planes that give the minimum and maximum curvatures, are called the principle normal curvatures (pncs). Each of them may be positive, negative or zero, corresponding to the defining curve having a hollow, hump or flat at p . As design information the two pncs are themselves of limited interest compared to various combinations of them.

Mean curvature is the average of the two values and Gaussian curvature is their product.

Positive Gaussian values mean that the curvature is all in the same direction, that is, a hollow or a hump. Negative Gaussian values mean that there is curvature in two opposite directions, or a saddle plate. A zero Gaussian value means that there is curvature in only one direction such as a cylinder.

These terms are defined in TABLE 3.I. and shown in Figure 3.1.

TABLE 3.I
CURVATURE DEFINITIONS

CURVATURE is smooth deviation from a straight line. As applied to a surface it is smooth deviation from a flat plane.

SINGLE CURVATURE is deviation in only one direction, such as a bilge radius plate in the parallel mid-body of a ship or developable surfaces on planing boats, indicated by zero Gaussian curvature value.

DOUBLE CURVATURE is deviation in two directions approximately normal to each other, such as humps and hollows, indicated by positive Gaussian curvature values.

REVERSE DOUBLE CURVATURE occurs when curvature in the two directions is in opposite directions, such as a saddle plate, indicated by negative Gaussian curvature values.

3.3 Curvature Indicators

Most lines development/fairing systems use various curvature indicators as a fairing design tool. These indicators can also be used as a control on the amount of curvature that is acceptable in both the transverse and longitudinal directions per unit length or area.

For curves, “porcupine plots”, which show lines in the direction of the principal normal along the curve having lengths proportional to the curvature. This type of plot can be used to see the effect of changing the curve so as to reduce the variation in curvature over the length of the curve. That is to smooth it out and/or keep the curvature below a certain value.

For surfaces, proportional tufts, contours and graded color areas are used to show mean or Gaussian curvature. A typical surface curvature color coding scheme, such as that used by AutoShip, shows negative mean curvature in shades from green to blue for increasing value and positive mean curvature in shades from yellow to red. Gaussian curvature shows humps red, hollows green and reverse double curvature (saddles) blue. Again these tools can be used to eliminate curvature that is known to cause problems for shell plate development. As most systems allow the user to set colors and shades according to various curvature values, they could be set to give an almost automatic warning when curvature was beyond that desirable by a shipyard.

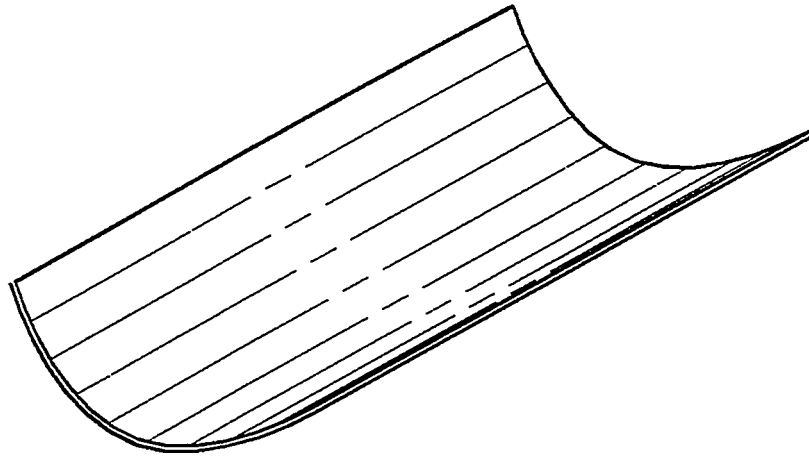

SINGLE CURVATURE - CYLINDER

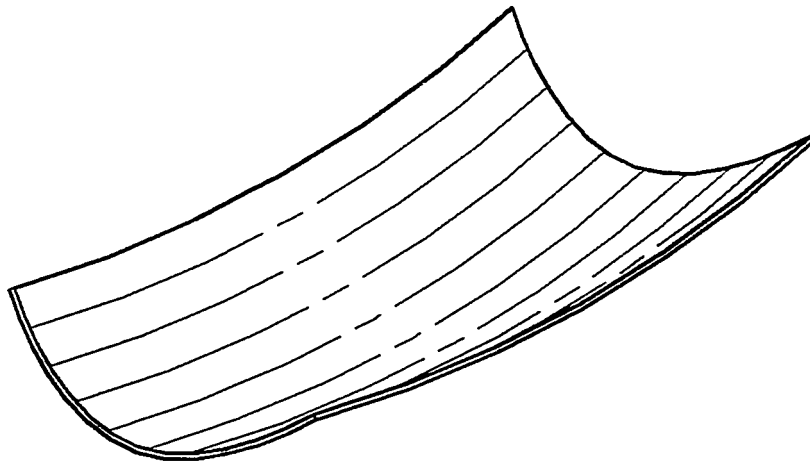

DOUBLE CURVATURE - HUMP OR HOLLOW

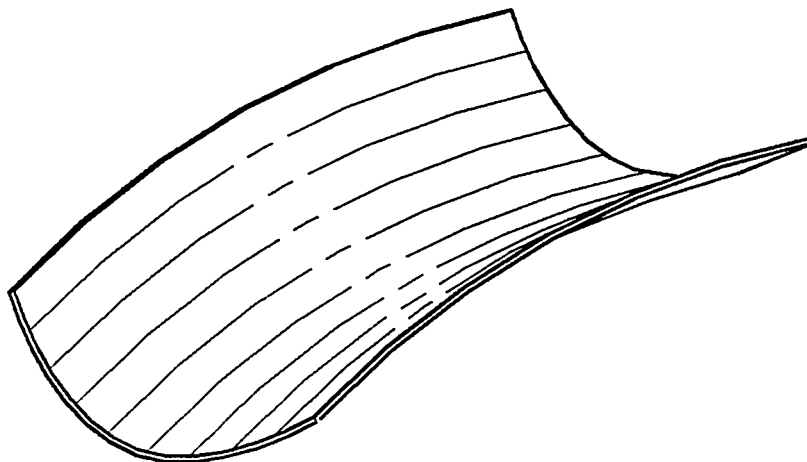

REVERSE DOUBLE CURVATURE - SADDLE

FIGURE 3.1 - TYPES OF SHELL PLATE CURVATURE

4.0 LINES DEVELOPMENT

A Lines Drawing developed without attention to the impact on production of its various work content aspects can increase the work content significantly. Clipper bows, cruiser sterns, stem aperture profile, faired bulbous bows and inappropriately located chines can all add work content. Therefore when preparing a lines drawing, the following items should be considered from a producibility view point:

- Upper stem
- Lower stem
- Bulbous bow
- Upper stem
- Lower stern
- Chines

Each of these will be discussed in detail but first the use of curvature measurement will be covered as the correct fairing of lines and minimizing the extent and rate of change of curvature on the hull surface offers the greatest potential for reducing the problem of defining producible shell plates.

4.1 Use of Surface Curvature Measurements to avoid Difficult Shell Plates

Many of the computer aided fairing packages available today incorporate surface curvature measurement tools. These can be in the form of surface curvature contours, color filled grids or directional tufts. Whatever the graphic system used it is a valuable tool that can aid in the preparation of minimum work content lines. Figure 4.1.1 shows the surface curvature contours used in the FORAN system. Some systems use plots of the distribution of tangential angles of curves on the hull surface to develop acceptable surfaces. This has been found useful to check fairness. Many curves that appear fair to the eye have been found to be unfair by looking at such plots.

Many of the CAL packages curvature indication are part of the shell development modules. Again, this can be curvature contours or color filled areas and grids. Figure 4.1.2 shows the color filled strain grid approach used by ShipCAM. However, this is really too late in the design process to be of benefit to the ship designer preparing the lines.

To use these curvature indicators as tools to eliminate or avoid the definition of difficult shell plates, it is necessary for each shipyard to develop acceptable curvature criteria or standards. These will depend on the shipyard's cutting and forming equipment and processes, including whether or not they use line heating for forming shell plates. These standards can be maximum curvature in transverse and longitudinal directions, maximum backset and maximum twist per unit of measure for different plate thicknesses and maybe even material type. The ship designer would then check the hull surface and where the standards were exceeded would make changes to bring the surface curvature within the limits of the standards.

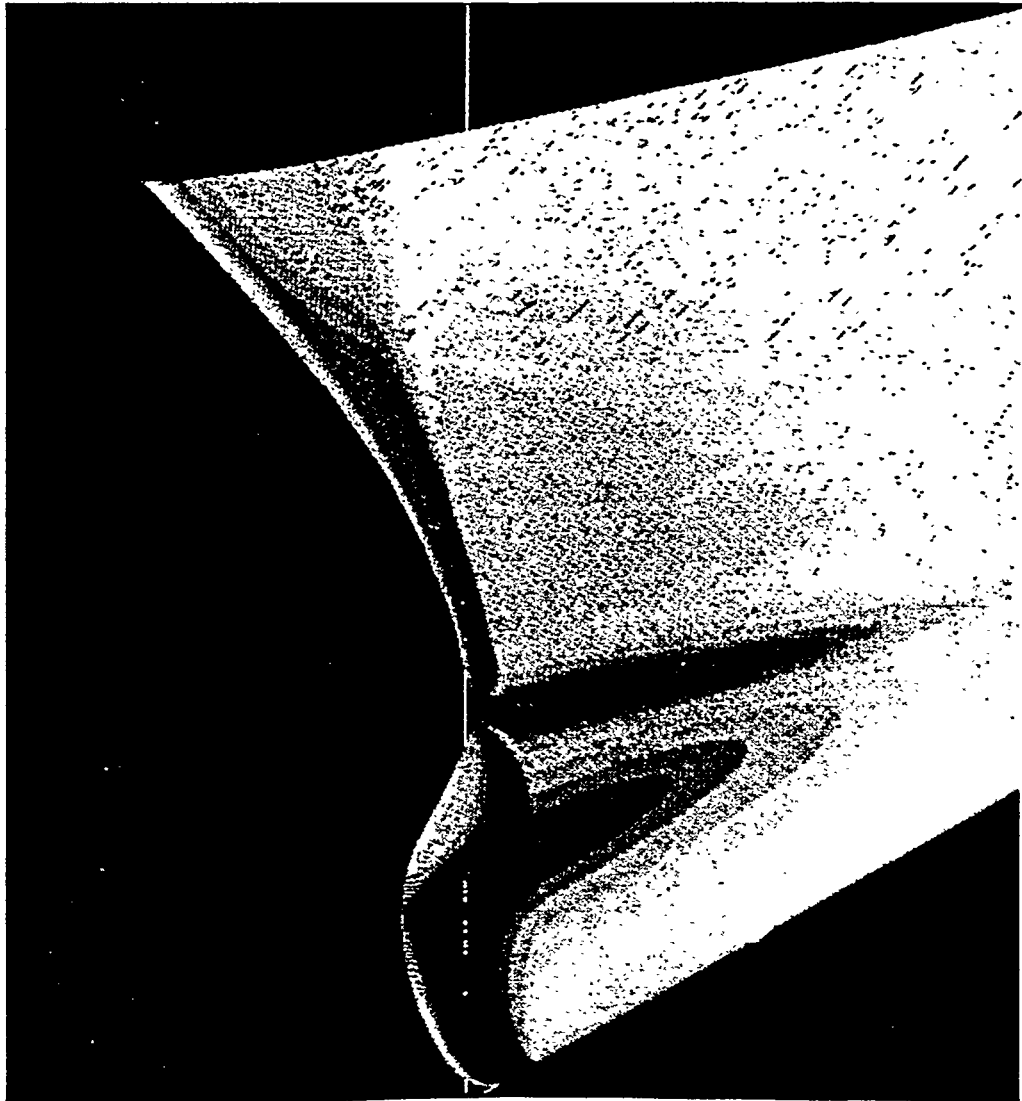

FIGURE 4.1.1 - SURFACE COLOR SHADING

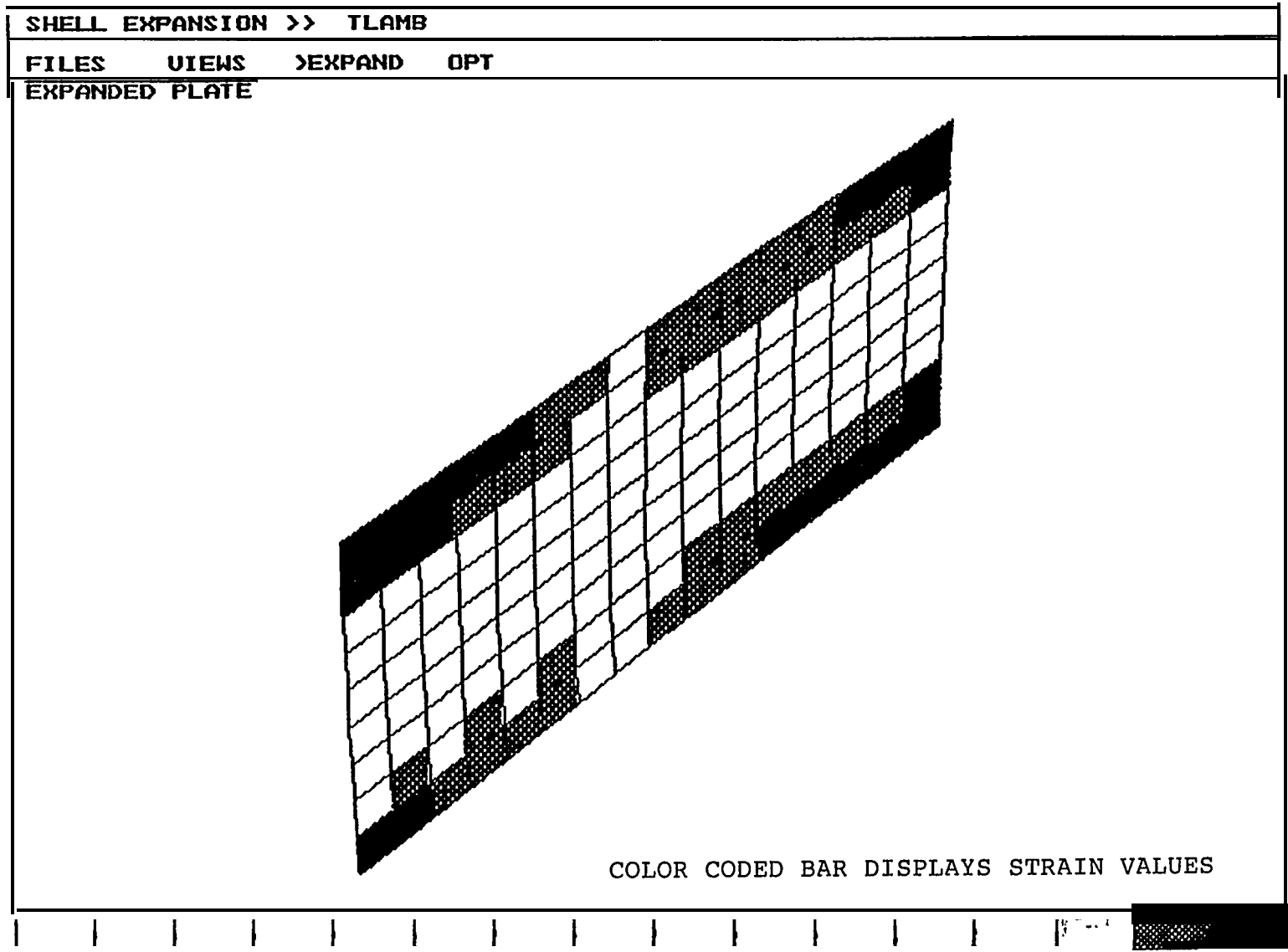

FIGURE 4.1.2 - SHELL PLATE

CODED STRAIN MAP

Even when this approach is followed there will still be areas on the hull surface of a typical ship where the curvature will be beyond the acceptable limits. The goal is to minimize these areas and to utilize detail design approaches in these areas that use the best production solutions for these difficult shell plates. Some of these approaches are discussed in the remainder of this guide.

4.2 Upper Stem

The upper stem of a ship is one area where designers regularly introduce reverse double curvature without any apparent concern about its work content impact. Curved upper stems and “clipper Bows” may be aesthetically pleasing but they also cost a lot compared to simpler stems. Even slight departures from a straight line stem will add to the difficulty of developing forming and erecting it. The simplest upper stem is one formed from a cone. Note that this will give elliptical waterline endings, unless the locii of radii centers is a vertical line. Then, and only then, will the waterline endings be radii. This is shown graphically in Figure 4.2.1.

The frames just aft of the stem and above the design waterline are usually concave to provide adequate deck area while maintaining nearly vertical shape in the vicinity of the design waterline and to provide the flare necessary to keep the deck dry. Again this results in reverse double curvature surfaces. Figure 4.2.2 shows this along with an alternative approach that achieve the same technical objective but reduces the work content. This approach uses straight frame sections along with chines.

4.3 Lower Stem

Most ships can be designed without the use of concave waterlines in the bow. For ease of production straight and convex waterlines are preferred as they will not have reverse double curvature.

The fore foot shape should be carefully determined to ensure a fair transition of the shell surface into the stem. A radius is often used by designers for the fore foot shape but it is unlikely that it is the correct shape. This is not usually considered in any detail at the design stage. The designer fairs the total ship and does not consider details. In the case of manually drawn lines the preliminary fairing will use 21 stations and waterlines spaced quite far apart. In this case local unfairness is easily missed. To ensure that the fore foot shape gives fair endings, it is necessary to use closer station and waterlines in this area. In the case of computer aided fairing the fore foot area should be given closer attention. Unfortunately, it is usually left to the final fairing process to work out any resulting problems. This problem is shown in Figure 4.3.1

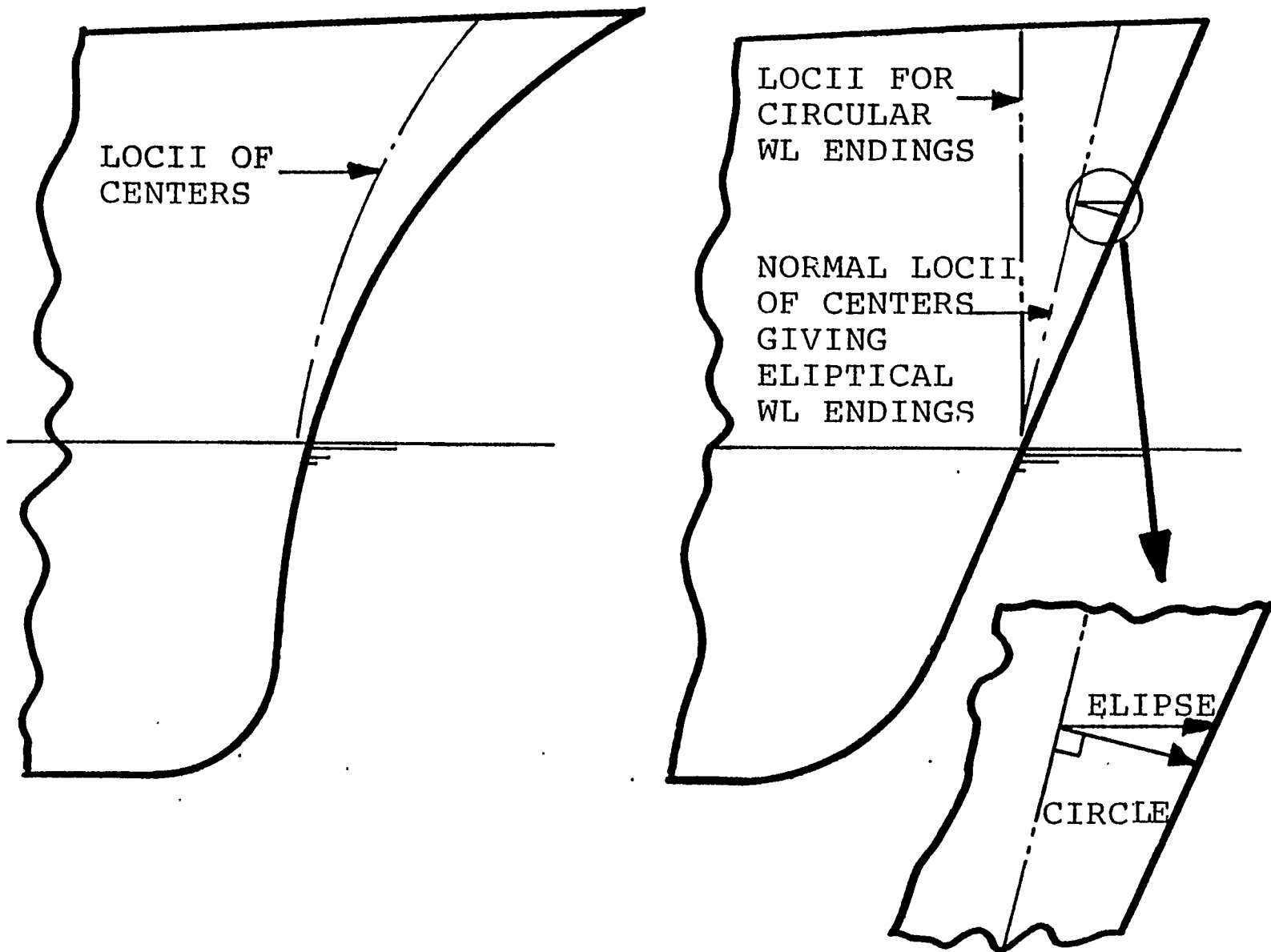
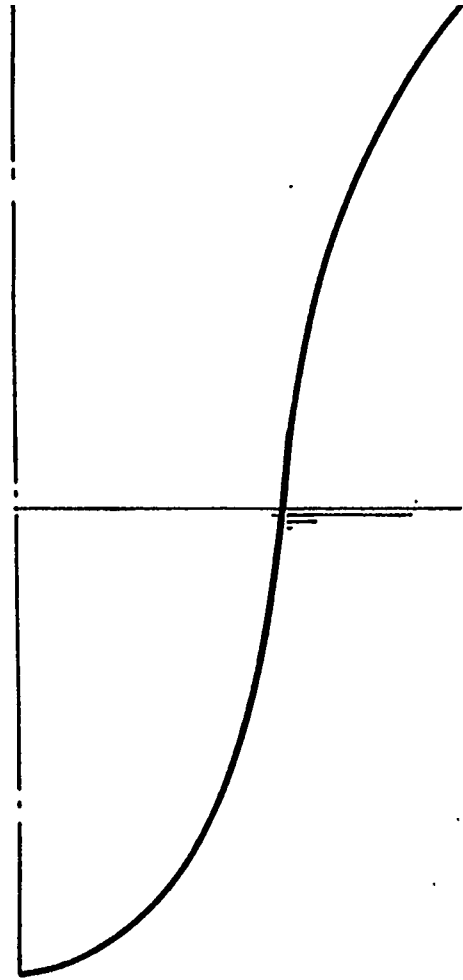
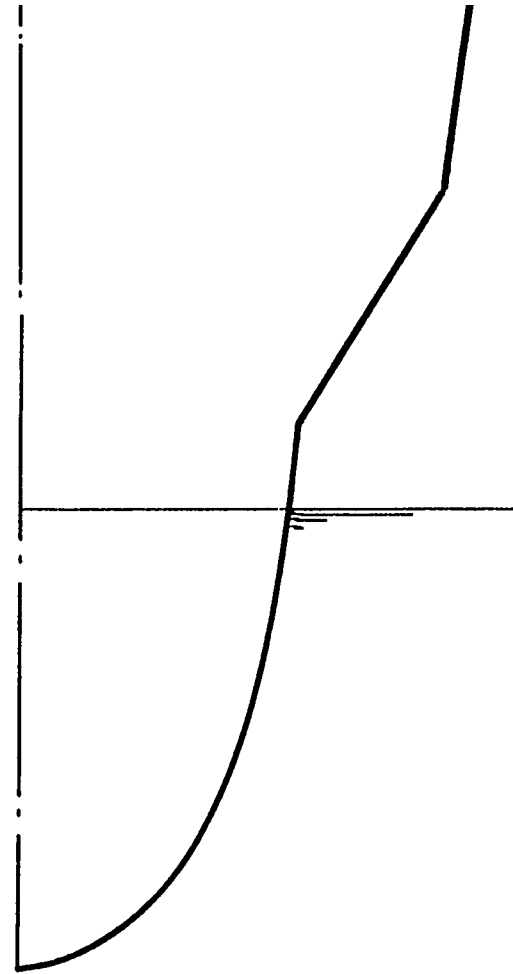

FIGURE 4.2.1 - UPPER BOW SHAPING



NORMAL BOW FLARE



FLARE FROM STRAIGHT FRAMES AND CHINES

FIGURE 4.2.2 - SECTION DESIGN TO AVOID REVERSE DOUBLE CURVATURE PLATES

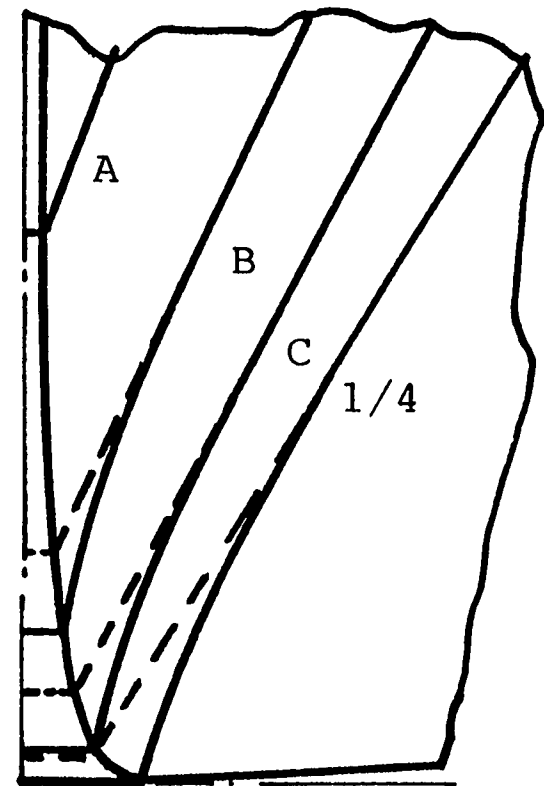
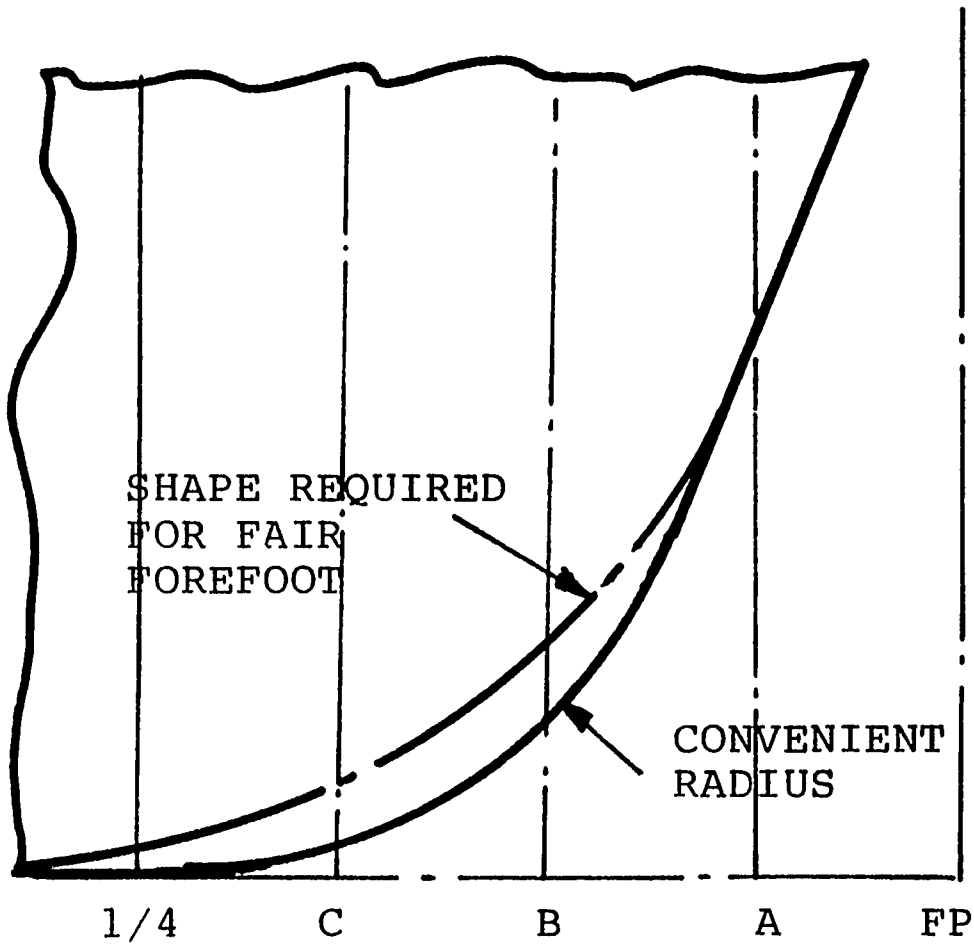

FIGURE 4.3.1 - EXAMPLE OF FAIRING PROBLEM

4.4 Bulbous Bow

There are many lower stem arrangements that are loosely called bulbous bows. Early applications involved transferring displacement from the fore body in way of the load waterline to the stem fore foot in the form of a faired in bulb as can be seen from Figure 4.4.1. It should be obvious that the faired in type of bulb introduces many plates that have reverse double curvature that are difficult to develop, form and erect. One way to reduce this problem is to not fair in the bulb. Instead a chine is introduced at the intersection of the bulb and shell surfaces.

Partial stem castings have been used in way of the design waterline, for bulbous bows where they are faired into the shell. The casting can be eliminated and the shell work content significantly reduced by introducing chines as shown in Figure 4.4.1.

For a fine form hull, the preferred shape for producibility of the bulb in transverse section is a circle. If an inverted tear drop shape is desired the next best producibility approach is to build the bulb out of portions of two cylinders, two spheres, a cone and two flats as shown in Figure 4.4.2. For large slow speed hull forms, such as for tankers and bulk carriers, the “visor” type of bulbous bow, shown in Figure 4.4.3, can be made production friendly by attention to the shaping of the curved surface in the transverse direction.

4.5 Upper Stem

There are only a few basic upper stem types and recent ship designs have concentrated on only one of them. The early 1900 counter stem changed to the cruiser stem after World War II. Then the transom stem, which was first utilized on fast ships where at design speed the transom was “clear” of water resulting in beneficial resistance characteristics, was adopted for slow speed merchant ships. This was because of the obvious construction work content reduction. It was also because it maintained deck width aft and gave larger deck space, which was advantageous in the all aft deckhouse ships as well as deck cargo ships, such as container ships.

Unfortunately, even with the simpler transom stem ship designers still introduce details that result in additional work content. These details include sloping it in the profile view, providing curvature in the plan view and large radiused comer connection between the shell and transom. These high work content details are shown in Figure 4.5.1 along with suggested minimum work content details such as vertical transom in profile view, flat in the plan view and sharp comer connections.

4.6 Lower Stem - Single Screw

The single screw propeller aperture has evolved from the early stem post design to the “open” or “Mariner” type such as shown in Figure 4.6.1. Recently more merchant ships have been using “spade” type rudders even though they have larger rudder stocks. Figure 4.6.2 compares the parts and the various work sequences involved in both approaches and it can be easily seen that the spade rudder installation will have the lowest work content improperly integrated into the upper and lower stem design.

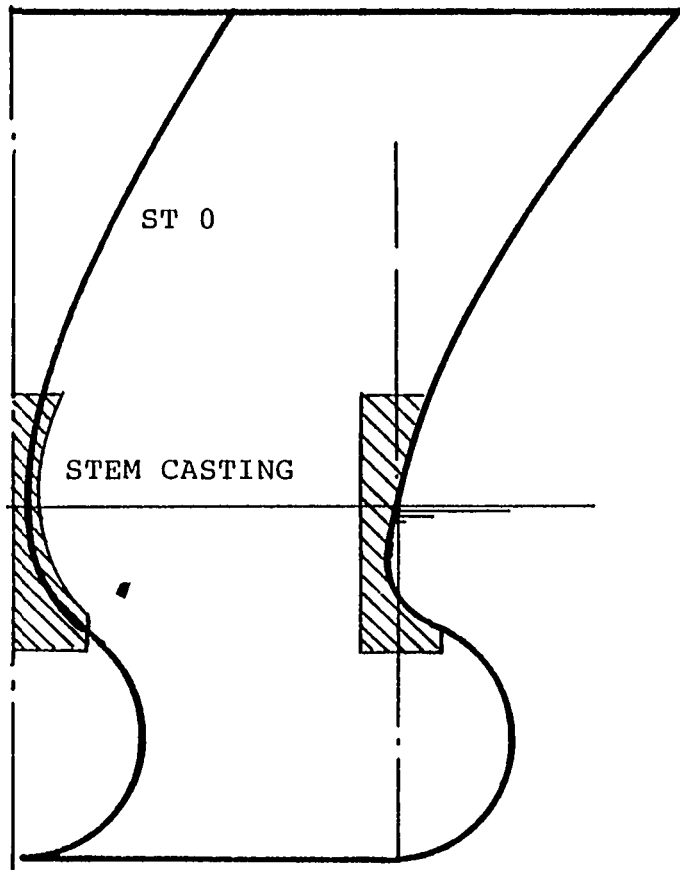

FAIRED BULB

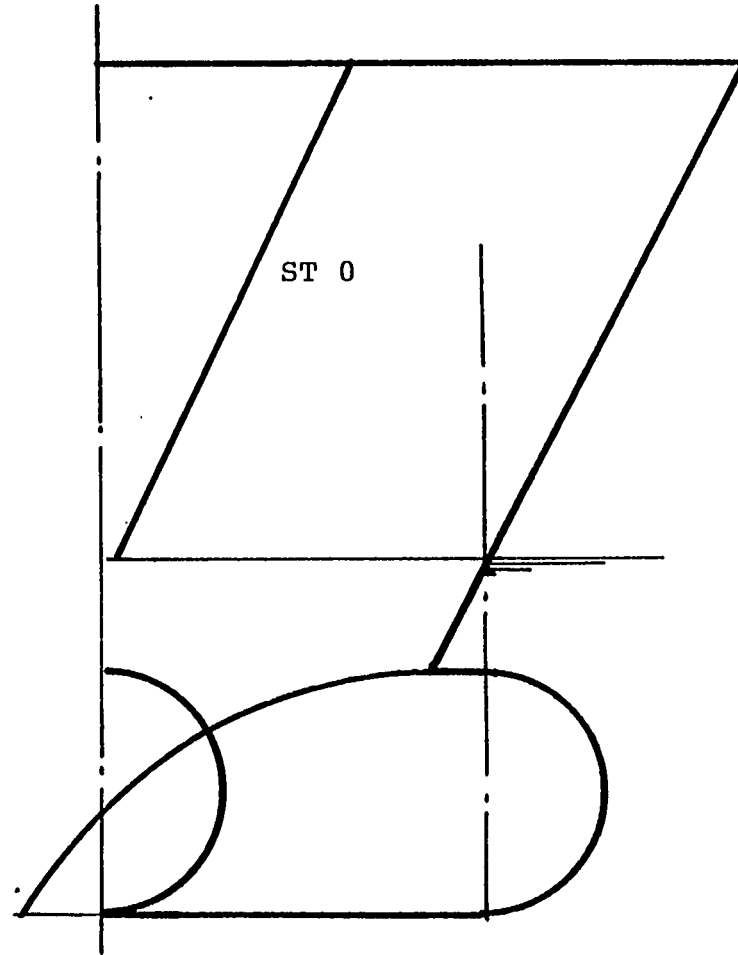

BULB WITH SHELL CHINE

FIGURE 4.4.1 - FAIRED VERSUS CHINE BULBOUS BOW

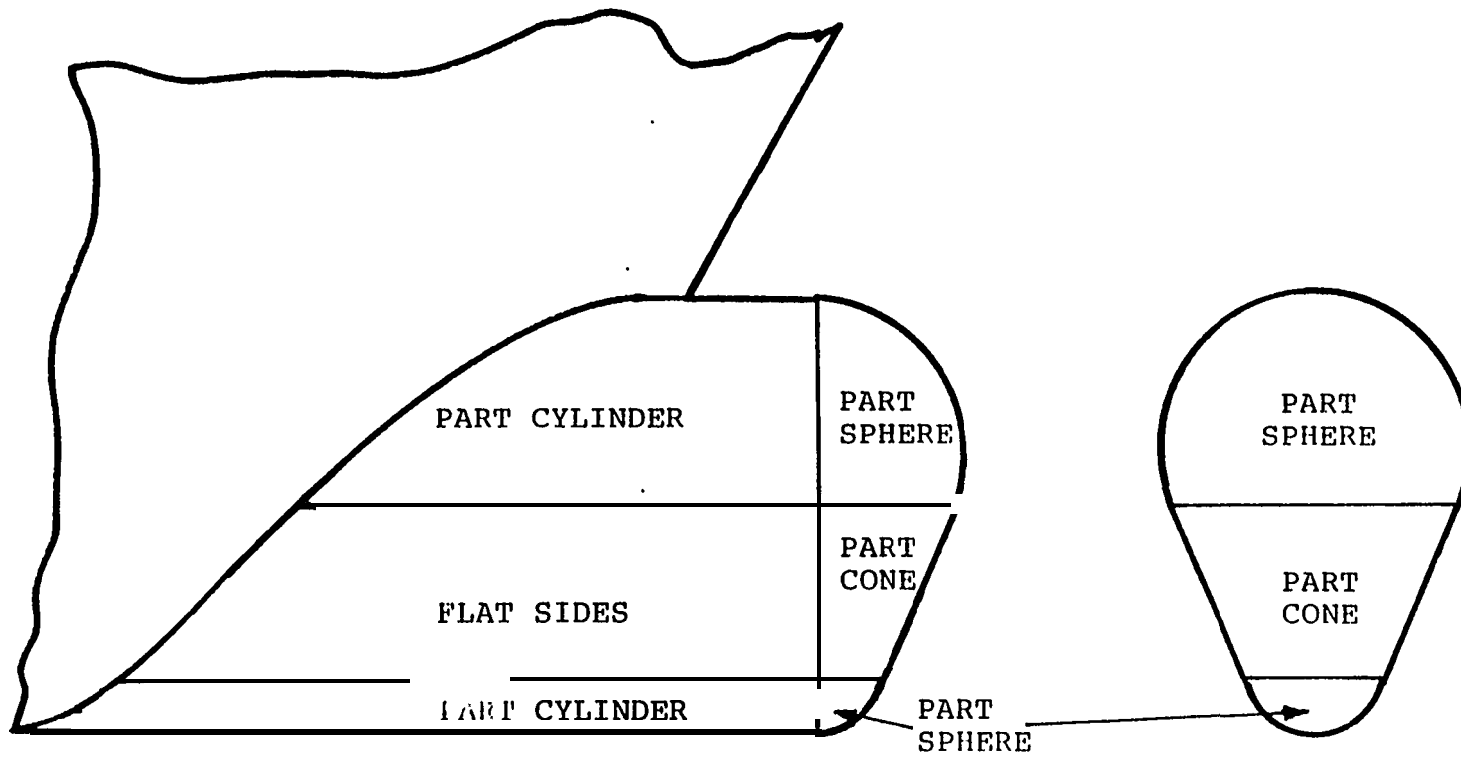

FIGURE 4.4.2 - BULBOUS BOW FABRICATED FROM GEOMETRIC SHAPES

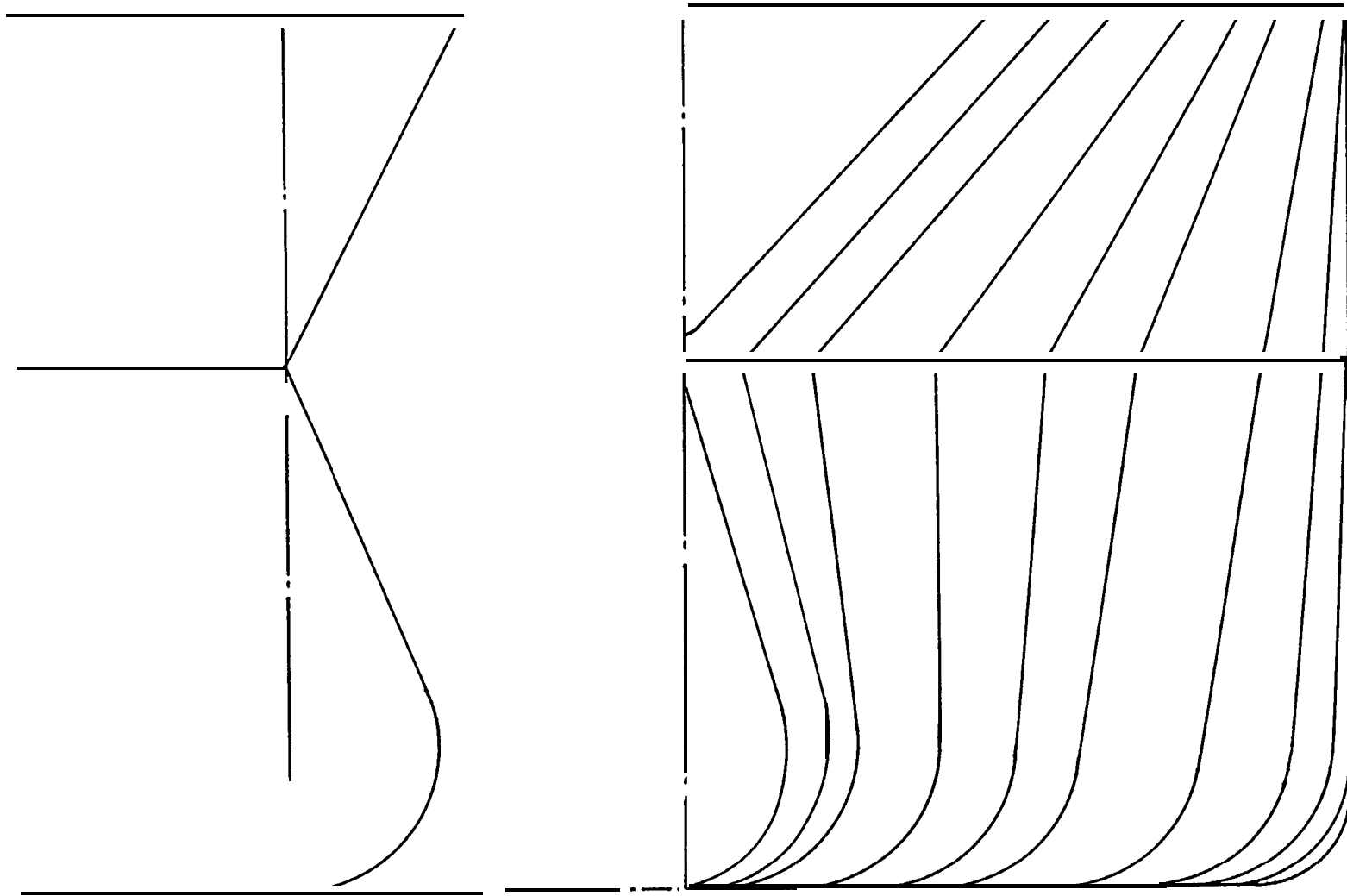
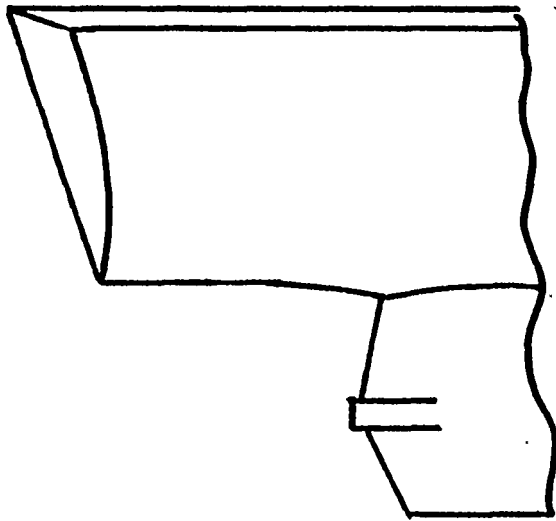
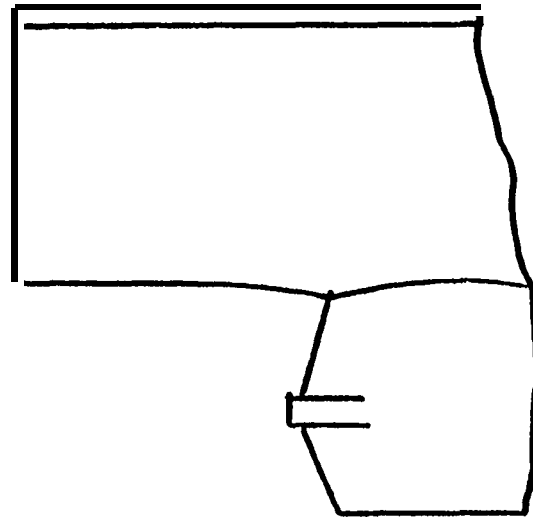

FIGURE 4.4.3 VIEW OF BOW FOR FULL FORM HULLS



CURVED AND SLOPED TRANSOM
HIGH WORK CONTENT



VERTICAL AND FLAT TRANSOM
LOW WORK CONTENT

FIGURE 4.5.1 - TRANSOM SHAPING

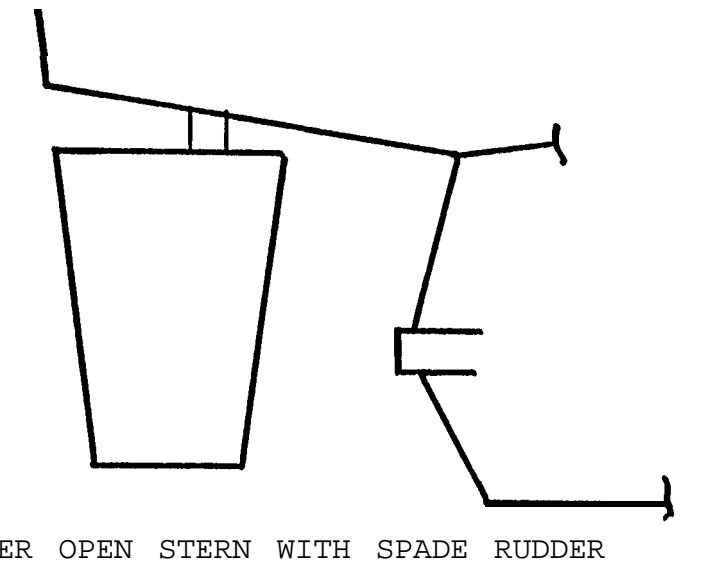
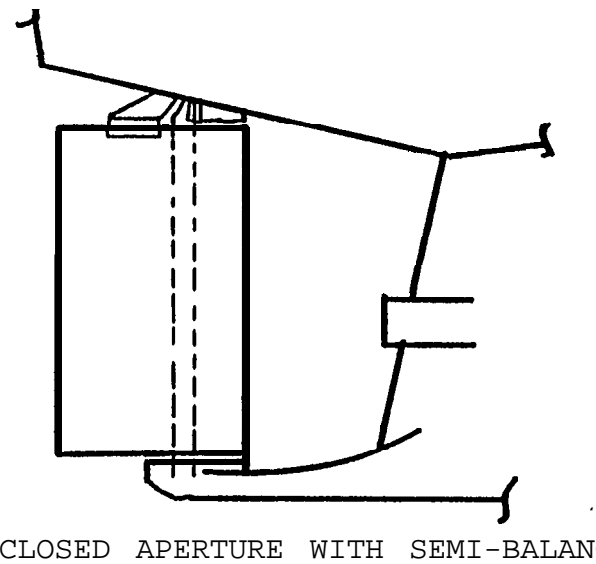
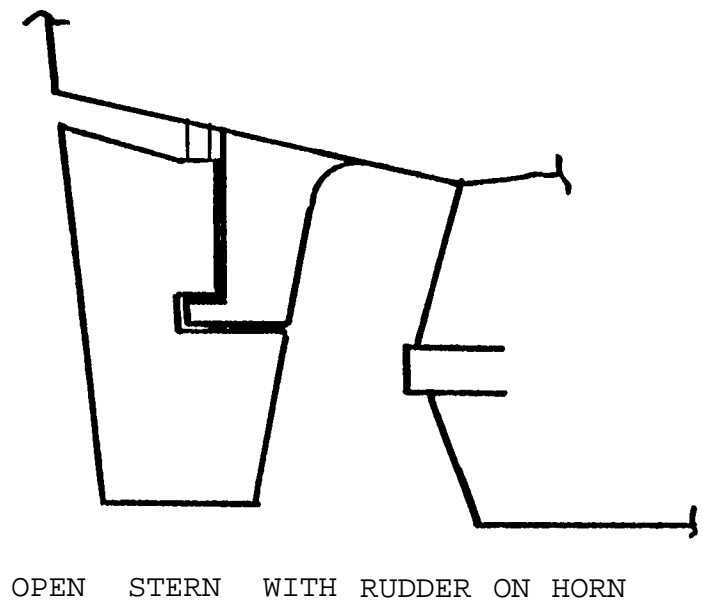
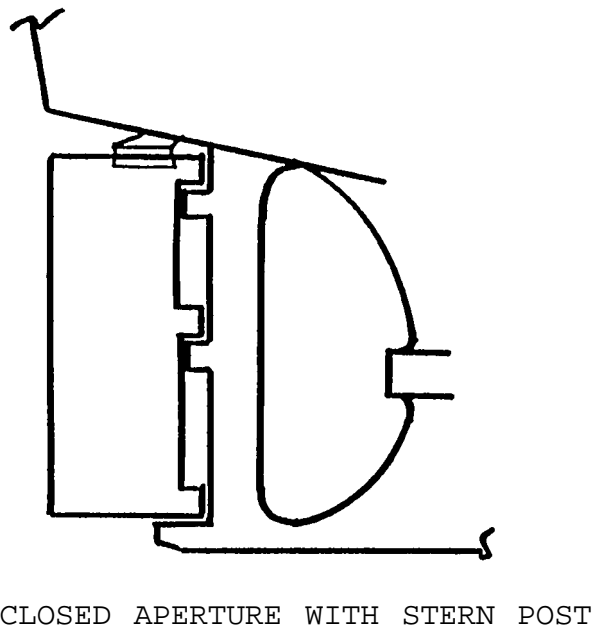

FIGURE 4.6.1 - PROPELLOR APERTURE AND RUDDER TYPES

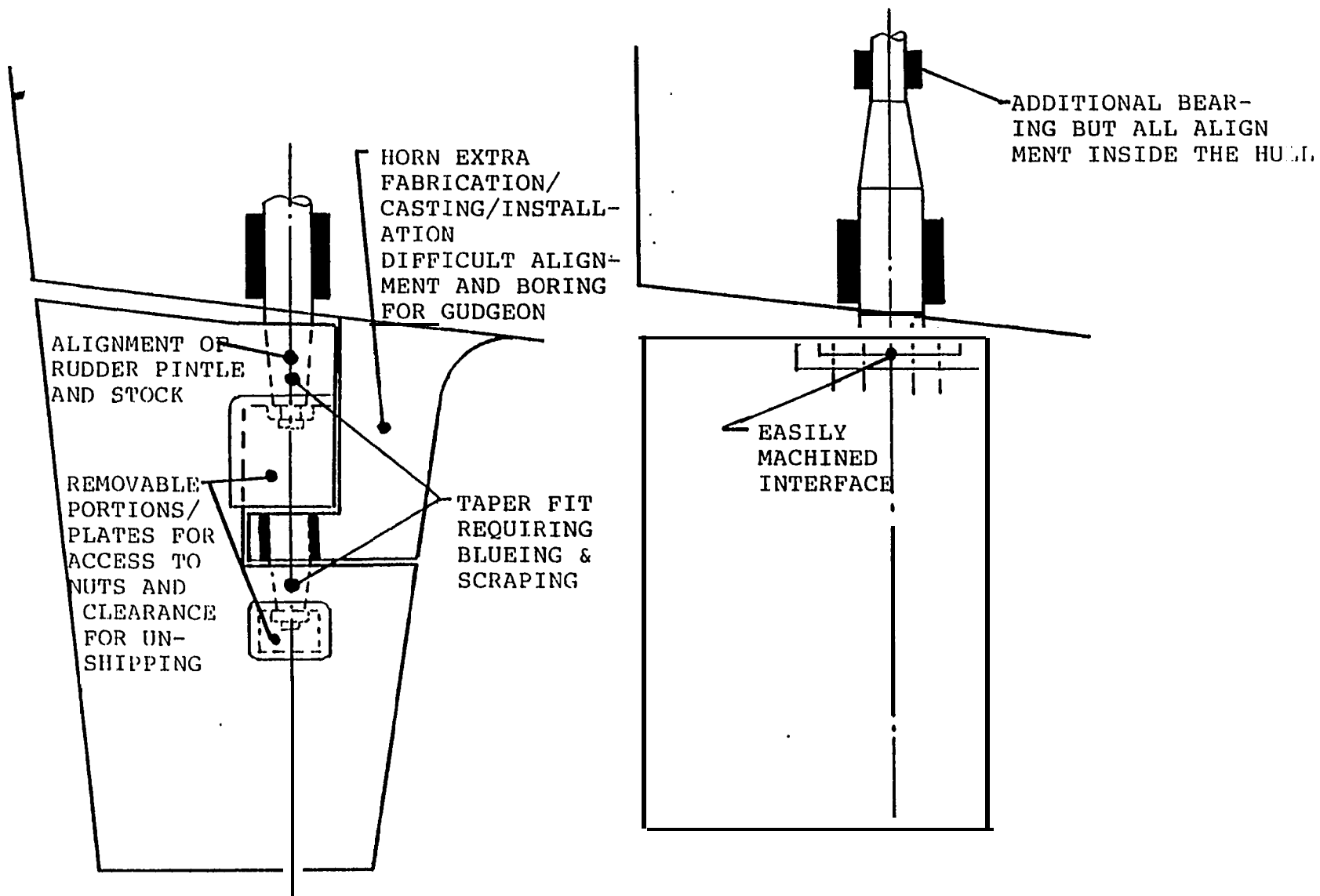

FIGURE 4.6.2 - PRODUCIBILITY ASPECTS OF TWO RUDDER TYPES

At one time all stern frames were designed as castings. This enabled complex shape to be incorporated into the design of the aperture and waterline endings. The cast stem frame was also erected early in the build sequence along with the stem to provide reference structure from which to build the remainder of the ship. In the early 1960s the widespread use of structural sub-assemblies (modules or blocks) permitted and perhaps demanded the integration of the upper and lower stem design including the stem frame. At first this only resulted in the use of fabricated instead of cast stem frames that still had to be integrated into the stem block. Today the stem frame should be integrated into the block design. Also, to make it easier to develop, form and erect the shell plates surrounding the lower stem the ship designer should simplify the lines by selecting the aperture shape and eliminating tight curvature by incorporating chines as shown in Figure 4.6.3.

The stem of a single screw ship is an area that usually has considerable reverse double curvature surfaces. As a minimum, to reduce the problem this gives, seams and butts should be located at the transition or inflexion lines from convex to concave surfaces. While this will improve the acceptability of the shell plate and reduce the work content by having double curvature shell plates instead of reverse double curvature shell plates, it will still be significant.

The work content of shell plates for single screw ships can be significantly further reduced by separating the normal faired hull into parts. This can be done in a number of ways. One way is to try to follow the normal hull shape as closely as possible by incorporating chines as shown in Figure 4.6.4. Another way is to design the after body as a cut up stem type, such as used in warships, and to add on a shaped skeg that can incorporate the shaft and its bearings and maybe even the gearing as shown in Figure 4.6.5. Both approaches can be used with minimum adverse impact on the performance of the ship but with significant reduction in work content.

4.7 Lower Stem - Twin Screw

For twin screw designs the cut up stem with open shafts and shaft brackets is certainly a lesser work content approach than faired hull with bossings. The twin bulbous shaped skegs is also a viable way to minimize work content. These approaches are shown in Figure 4.7.1

4.8 Chines

Many ship designers utilize chine hull forms on the basic assumption that they are easier to build than round bilge forms. Although this is generally true for small ships, especially if the hull surfaces are developable surfaces, it is not appreciated that chines can add work content to a design. A chine that crosses a deck has more work content just due to the increased complexity of the joint detail. Also sloped chines result in split frames, and additional flame brackets, resulting in more parts to process and handle. When a chine is sloped in the profile view it can present a problem if the ship is constructed in blocks. In this case it would be better to arrange the chine to be horizontal thus providing a natural alignment plane for the block. These concepts and alternative reduced work content approaches are shown in Figure 4.8.1.

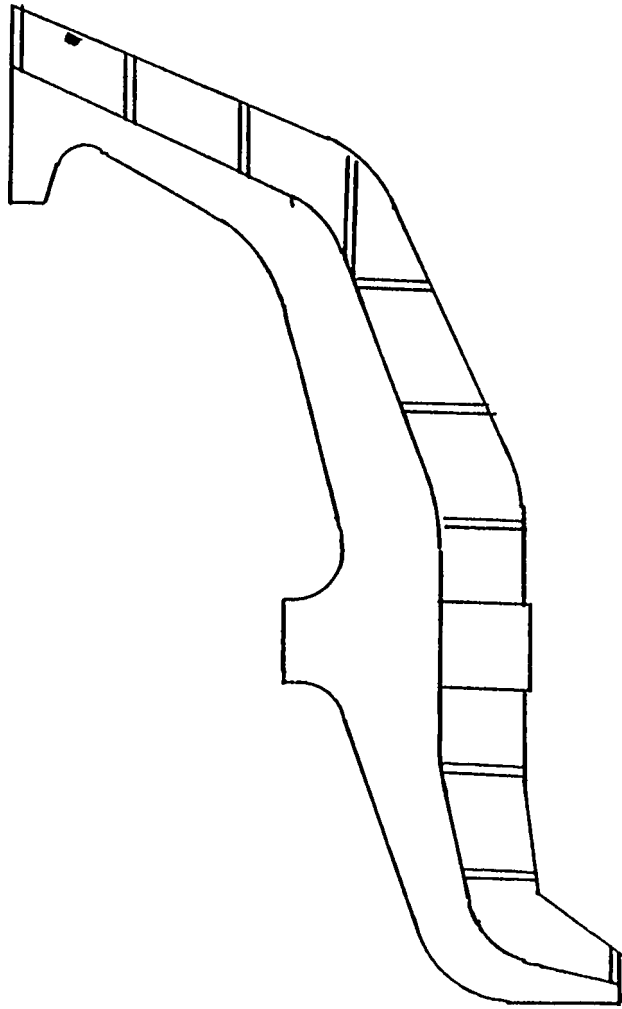

CAST STERN FRAME
COMPOUND CURVES NECESSITATED
CASTING

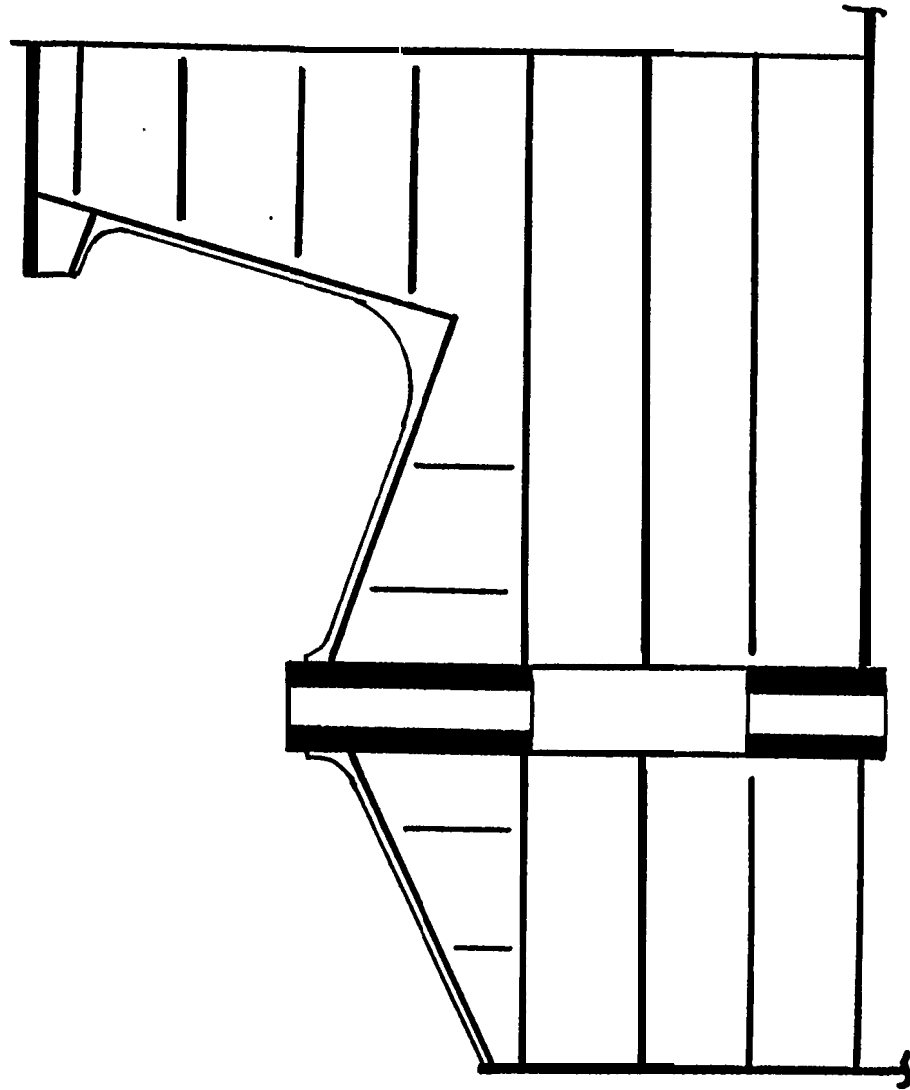

FABRICATED STERN FRAME
SIMPLE STRAIGHT LINES AND CHINES ENABLE
STERN FRAME TO BE FABRICATED AND INTEGRATED
INTO THE STERN MODULE

FIGURE 4.6.3 - INTEGRATED STERN BLOCK VERSUS TRADITIONAL STERN FRAME

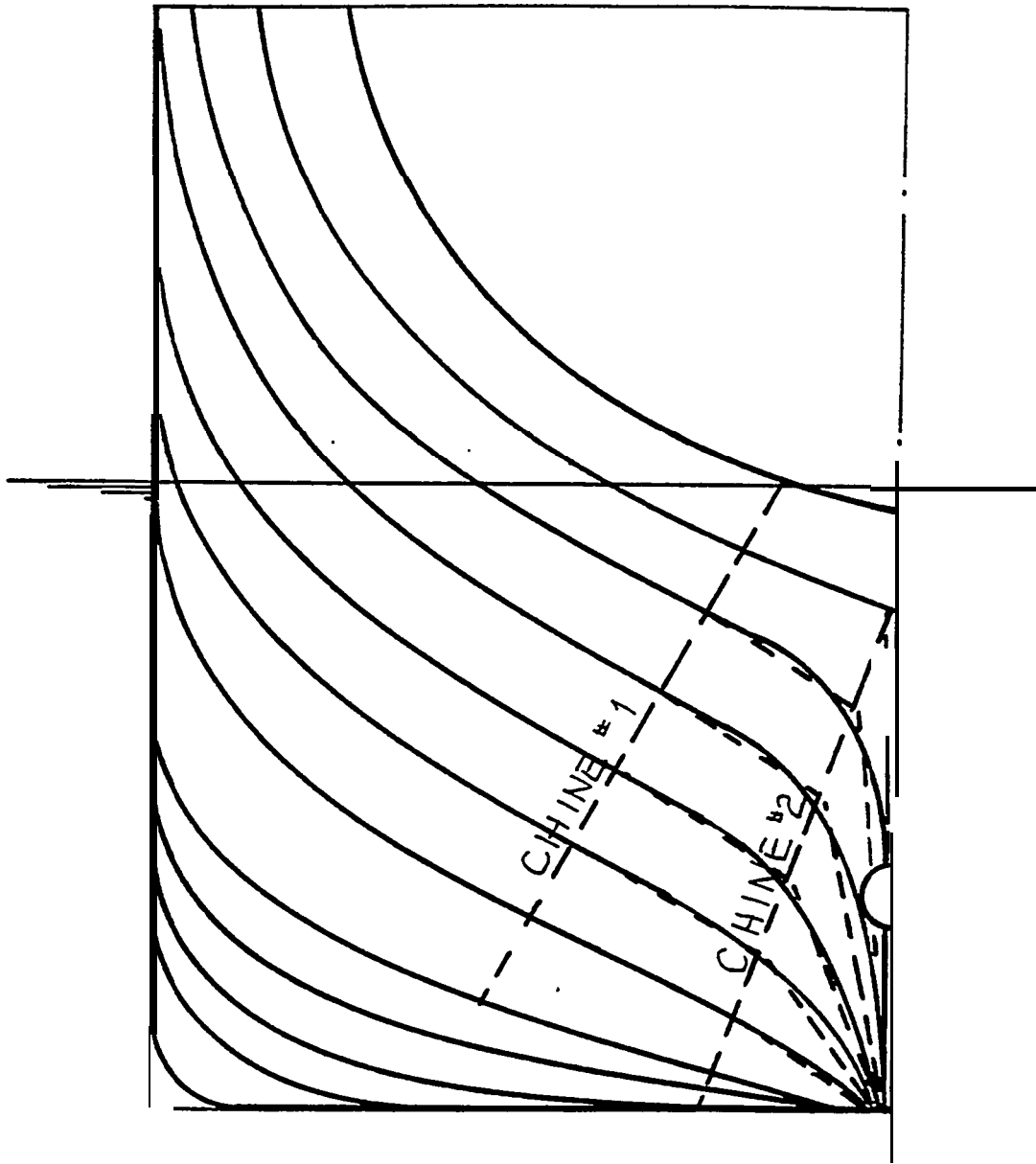

FIGURE 4.6.4 -USE OF CHINES TO SIMPLIFY STERN SHAPE

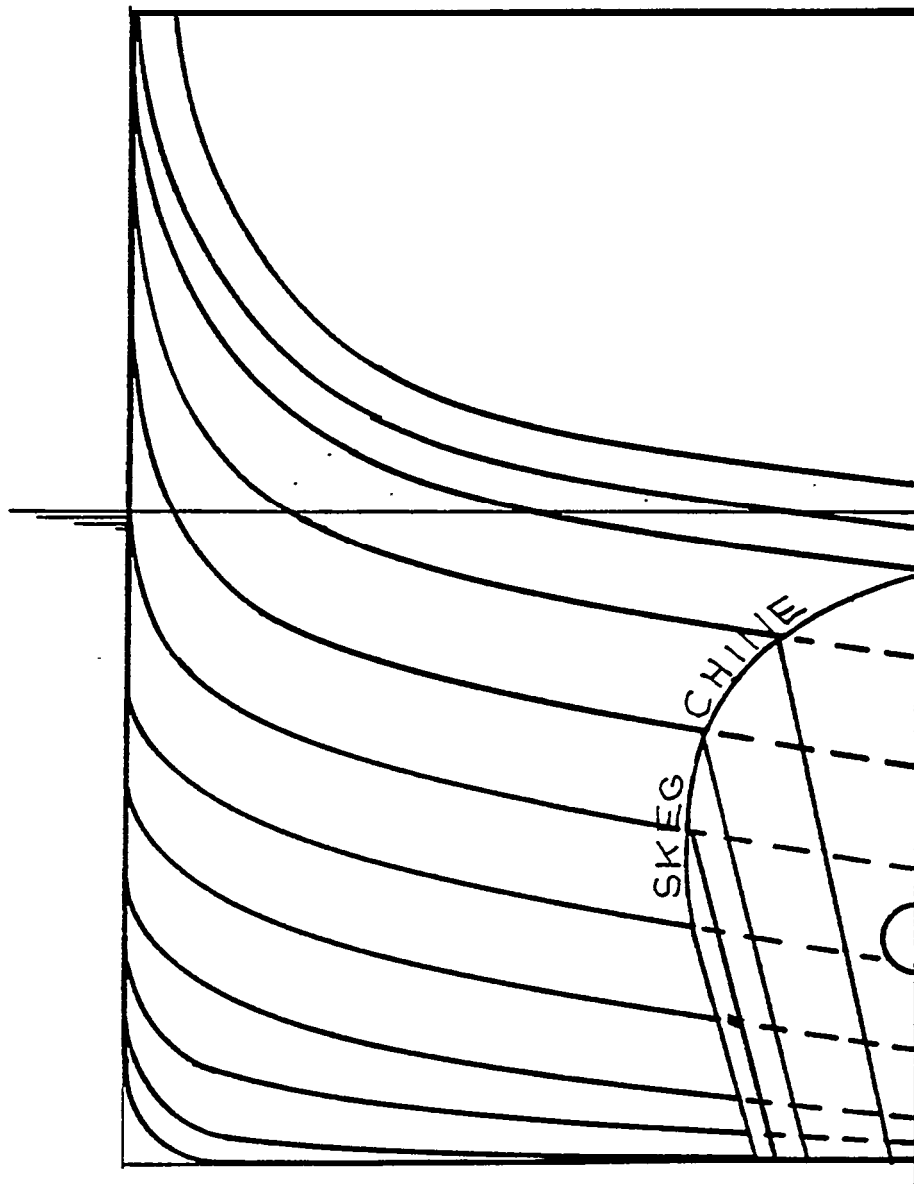

FIGURE 4.6.5 - USE OF SKEG TO SIMPLIFY STERN SHAPE

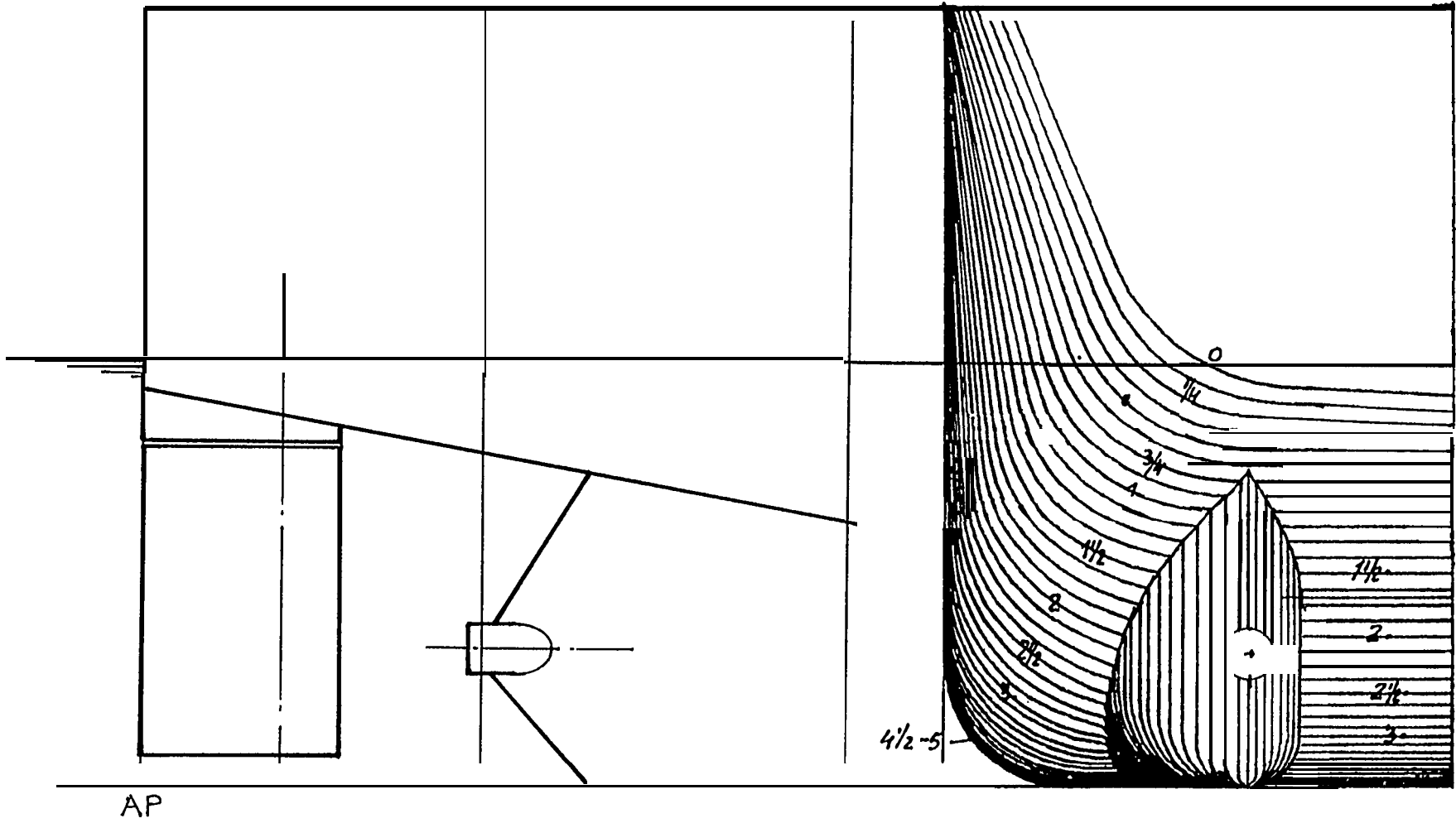
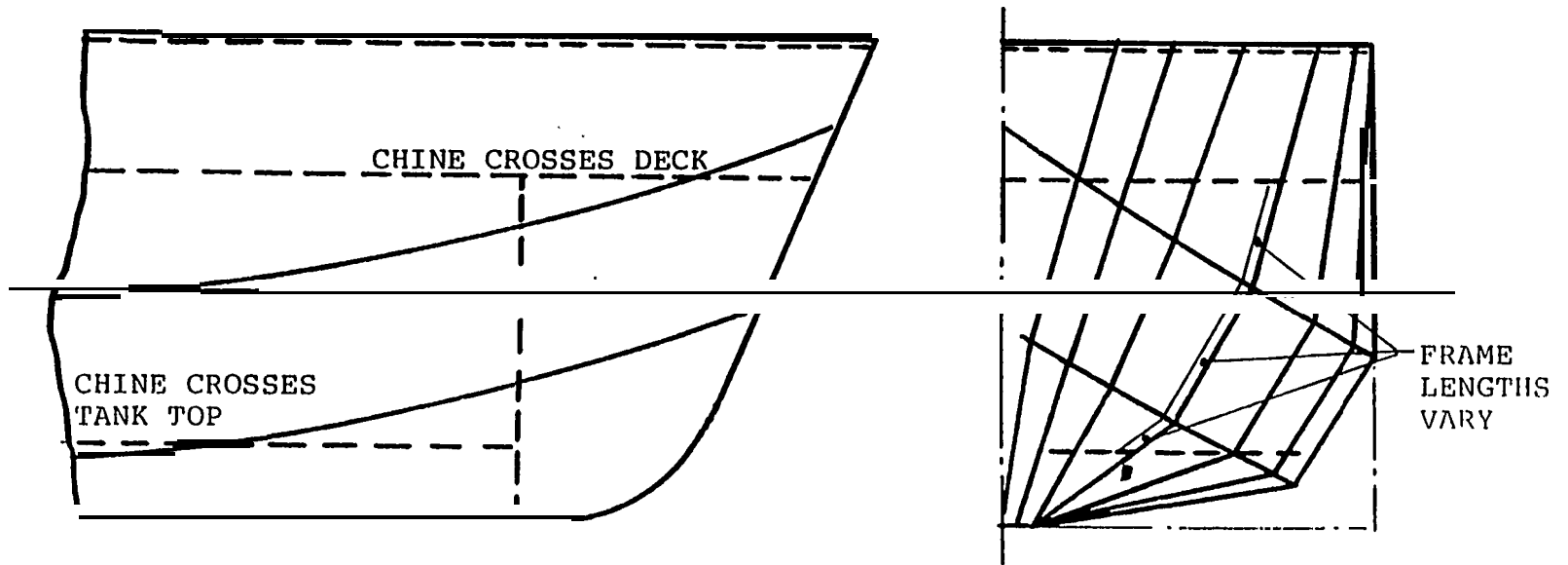

FIGURE 4.7.1 - TWIN SCREW SKEG DESIGN



[A] TRADITIONAL CHINE FORM

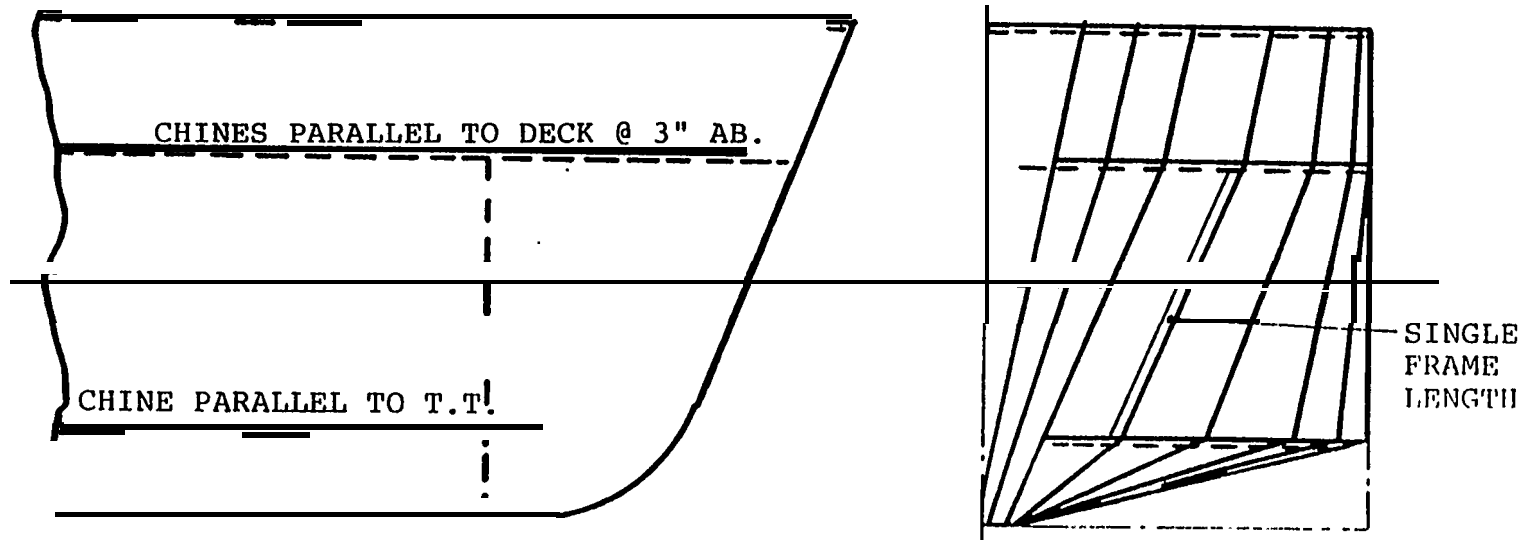

FIGURE 4.8.1 - CHINE LOCATION CONSIDERATIONS

5.0 SHELL PLATE DEFINITION

Even if the lines have been developed to minimize curvature and simplify known problem details, such as those discussed above, it is still possible to select shell plates that are unacceptable from the point of view of development and forming. This can be due to lack of understanding straking or because the designer does not know what to check does not have the tools to check what is necessary, even if the required checks are know or does not know the shipyard's forming capability.

On the other hand, if the developer of the lines cannot incorporate any of the ideas, it is still possible to minimize extent of curvature in any plate by following the approach discussed below.

The remainder of this section will discuss the process of defining shell plates, possible ways to check the acceptability of the selected shell plates and approaches that can assist in selecting the most producible shell plates.

5.1 The Start

Normally the plate definition starts with the Midship Section Drawing. Plate seams are shown on this drawing. The seam location may be simply a convenient division of the Midship girth or it may be based on a number of deliberate producibility or cost considerations such as:

- Use of Maximum Plate Length and Width
- Use of Standard Plate Length and Width
- Use of Design Standard Plates

The first one is a false cost reducer unless the ship is specifically designed to suit the maximum available length and width plates. That is, the ship beam and depth should be multiples of the maximum plate width and the hold or tank lengths should be the same as or multiples of the maximum plate length. The maximum plate length should also fit the best transverse frame/web frame spacing.

Using standard size plates that suit all the above considerations for a specific ship design is obviously better, even though the standard length and width may be smaller than the maximum available.

However, even greater benefits are attainable if the plates are standardized for cutting, bevelling and marking as well. This is discussed further later in Section 5.2.

5.2 Shell Plate Selection

Designers have used a number of methods to define the shell plates including plating half block models, plate body plans, 2-D Shell Expansion Drawings and Isometric Shell Plating Drawings. An experienced designer with a trained eye can effectively use a plate body plan to select plate seams and butts to avoid unacceptable shell plates. Most designers lack this skill and need all the tools they can find to assist them in avoiding unacceptable shell plates.

The traditional 2-D shell expansion drawing is an ineffectual tool for selecting acceptable shell plates. The isometric shell plating drawing for the fore and aft bodies of the ship used along with plate body plans is a much better approach. Figure 5.2.1 shows an isometric plating drawing for the fore body of a tanker. However, even this approach requires experienced users to ensure that unacceptable shell plates are avoided.

As the hull surface becomes shaped toward the ends the girths horn keel to deck generally diminish. The slopes of the frames change and the tight Midship bilge radius increases. Traditionally the seams are located so as to best fit the plates normal to the frames. This assures that the curvature and twist will be the minimum for the surface. Steelers (single plate strake forward or aft of narrowing double plate strakes) are used to accommodate fitting strakes into diminishing girths.

The move to block construction has resulted in vertical butts and horizontal seams at the erection joints of the blocks. This can result in plates with excessive double curvature and twist as shown in Figure 5.2.2.

The width of the flat keel is a classification society rule requirement. The designer often uses this dimension as the half keel siding and this is carried over to the Midship section design as the flat keel width. It is suggested that the flat keel plate should be as wide as the other shell plates. It should certainly be wide enough to extend over the keel blocks to allow for welding of the keel plate seam if the bottom blocks are split on the centerline. Figure 5.2.3 shows this concept.

As already mentioned in Section 5.1 there are significant differences between standard size plates and design standard plates. A design standard plate is not only identical in size, but also in marking, bevelling, etc. This can only be achieved by locating the stiffeners and web frames in the same position on each plate. To do this two options are possible. One is to consider stiffener and web spacing to suit a given plate size. The other is to select plate size to suit desired stiffener and web spacing. Figure 5.2.4 shows the difference in approach. It should be clear that all the factors that influence producibility and thus cost must be considered to reach a sound decision. It is a terrible waste to standardize ship designs and invest in facility changes and to lose much of the benefits therefrom by not understanding the impact of non standard shell plates.

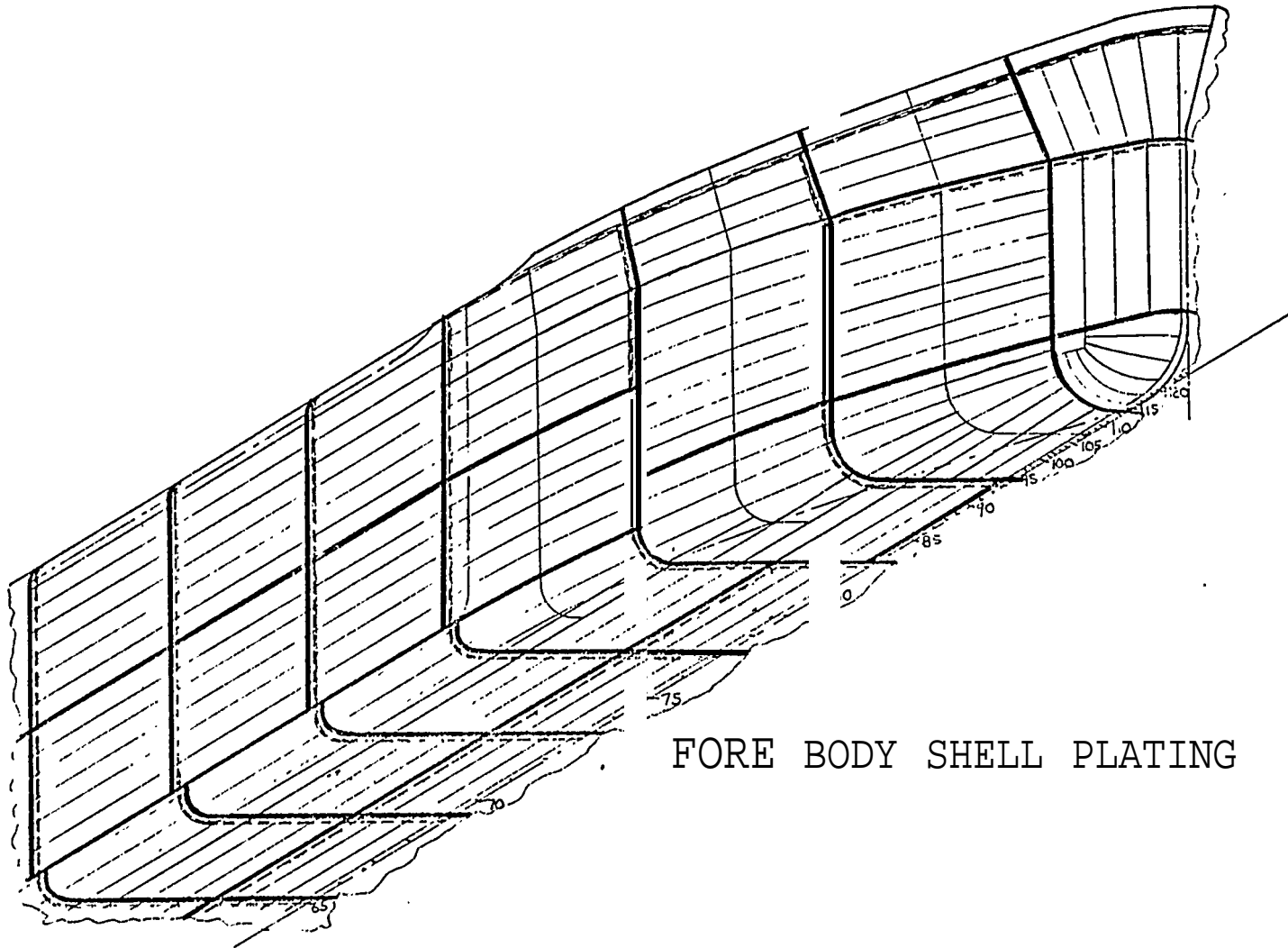

FORE BODY SHELL PLATING

FIGURE 5.2.1 - ISOMETRIC

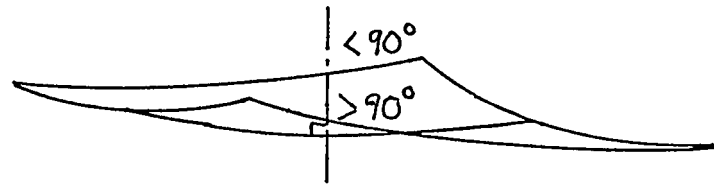
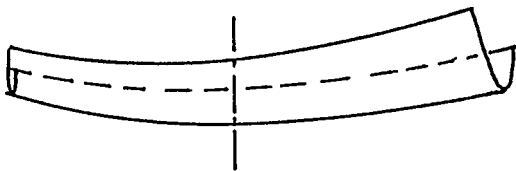
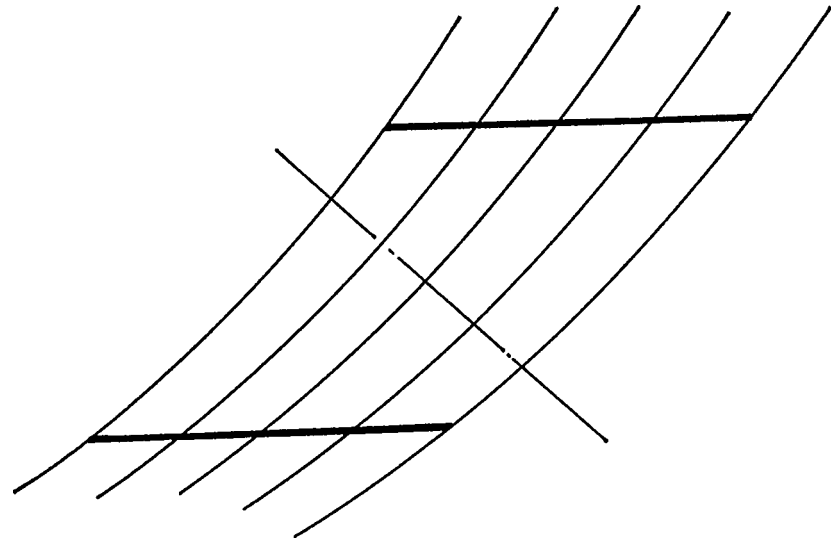
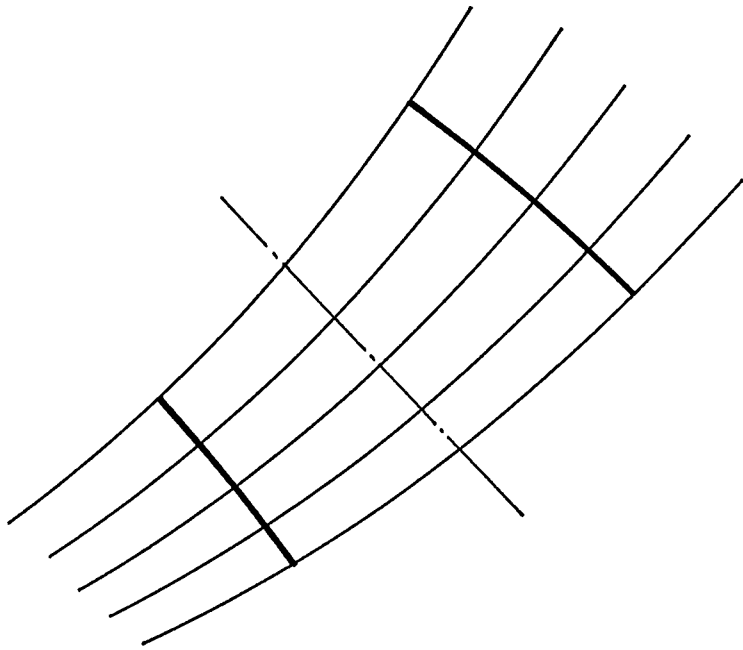

FIGURE 5.2.2 - IMPACT OF STRAKING ON BACKSET AND TWIST

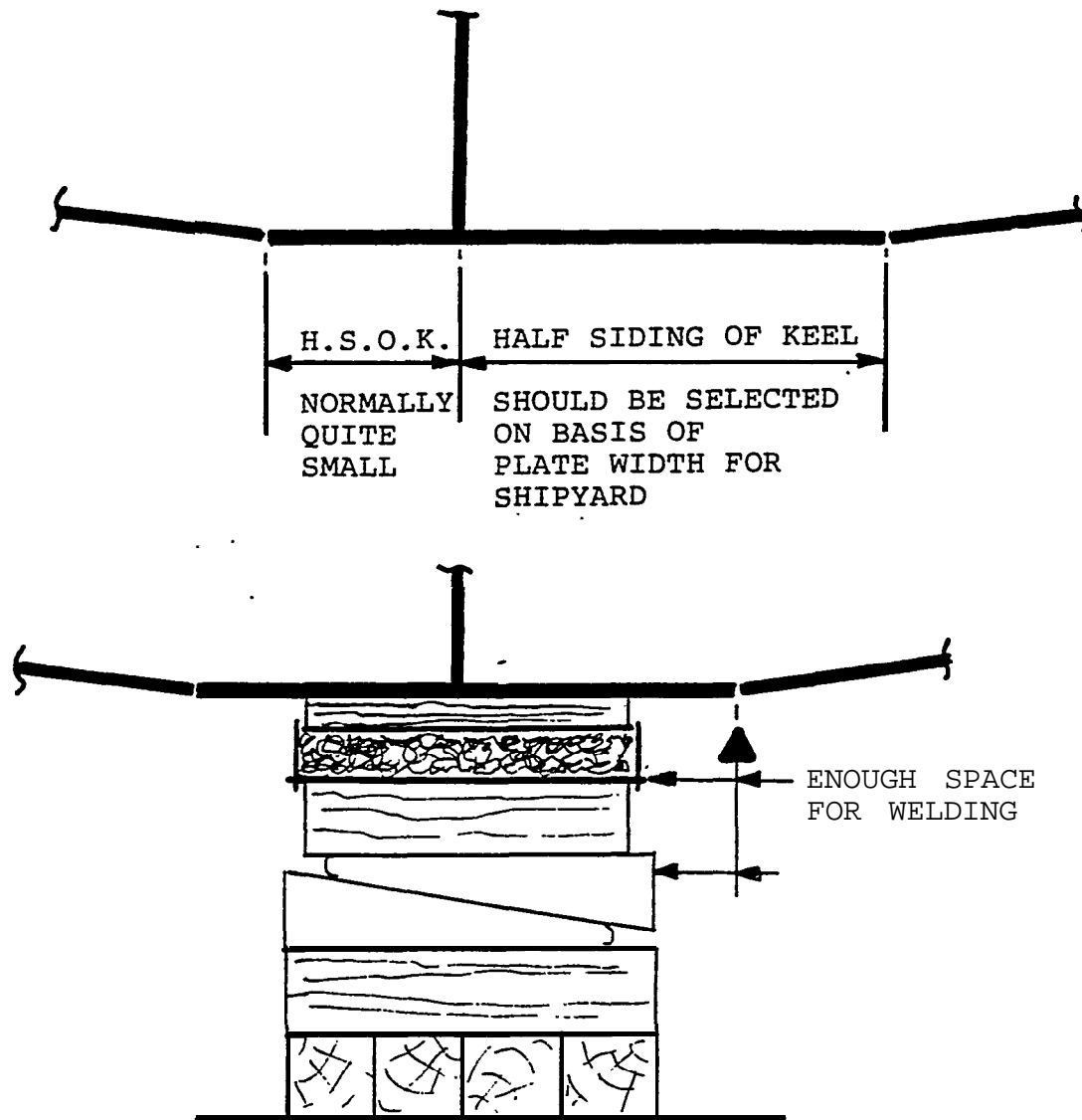
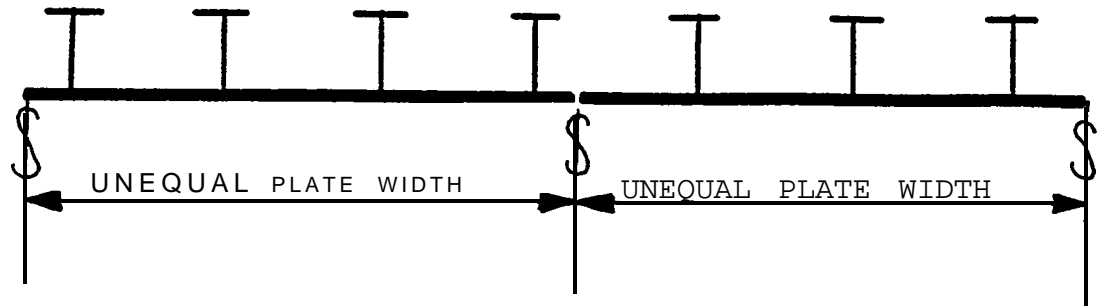
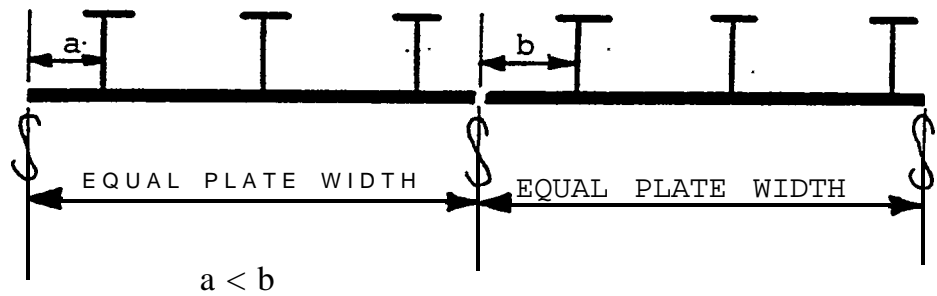

FIGURE 5.2.3 - FLAT KEEL PLATE CONSIDERATIONS



[A] NON-STANDARD PLATE WIDTH AND NUMBER OF STIFFENERS



[B] ALSO NON-STANDARD DUE TO DIFFERENT STIFFENER MARKING

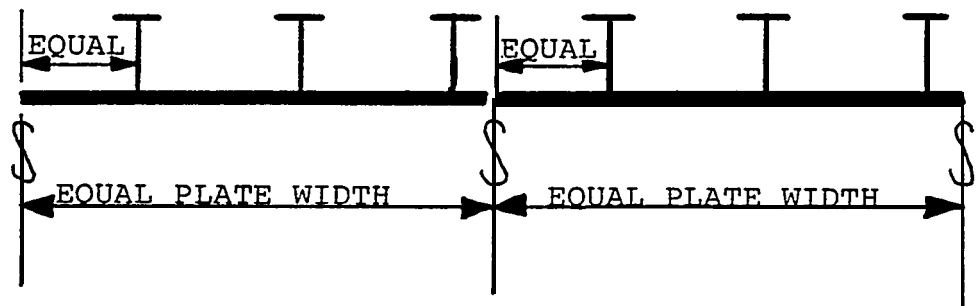

[C] STANDARD PLATES - PLATE WIDTH AND STIFFENER MARKING IDENTICAL

FIGURE 5.2.4 - STANDARD PLATES

5.3 Checking Shell Plates for Development and Forming Acceptability

The designer should be completely knowledgeable of the shipyard's forming capabilities, both machine and worker skills. Also if forming by line heating is utilized this must also be fully understood. One way to ensure this is to develop a Compound Curvature Shell Plate Acceptability Criteria Sheet. Such a document, for a hypothetical shipyard, is shown in Table 5.3.1

For every compound curvature shell plate development a sectional view, showing frames lined upon a roll line and leveled on both butt roll line intersection points, should be provided. This would clearly show longitudinal backset and twist. Longitudinal and transverse backset ratios and butt to butt twist angle should be calculated and shown on the sectional plot. These values could then be compared to the acceptability criteria and if not acceptable, modifications could be made to bring the plate within the criteria.

TABLE 5.3.I COMPOUND CURVATURE SHELL PLATE ACCEPTABILITY CRITERIA

A compound curvature plate can be defined by measuring the following characteristics:





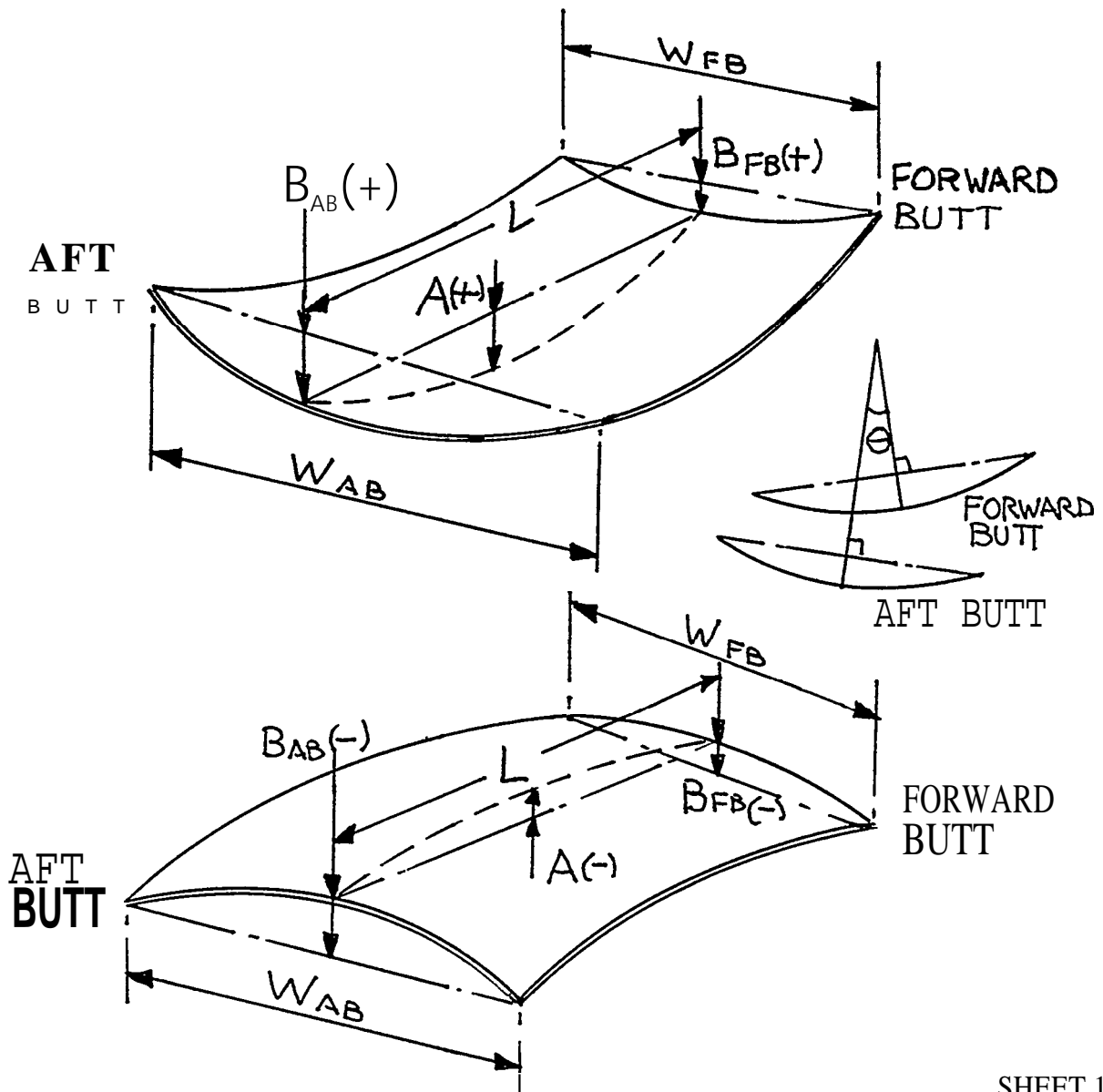

1. Longitudinal Backset Ratio (A/L)
2. Transverse Backset Ratio (B/W)
3. Twist over the length of the plate

These are shown below.

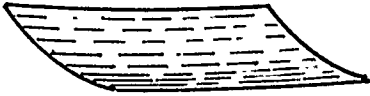

SHEET 1

TABLE 5.3.I - COMPOUND CURVATURE SHELL PLATE ACCEPTABILITY CRITERIA

CLASS	DESCRIPTION	LONGL BS RATIO	TRANSV BS RATIO	TWIST	REQUIRED FORMING	PRODUCIBILITY IMPROVEMENT
A	SMALL BACKSET NO TWIST 	0 ↓	0 ↓	0 ↓	ROLLER OR PRESS	
	SMALL BACKSET AND TWIST 	LESS THAN 0.02	LESS THAN 0.08	LESS THAN 10 DEGS	ROLLER OR PRESS THEN LINE HEATING OR LINE HEATING ONLY	
B	DOUBLE CURVATURE & MEDIUM TWIST 	0.02 ↓	0.08 ↓	10 DEGS ↓	ROLLER OR PRESS THEN LINE HEATING	RESTRAKE TO BRING WITHIN CLASS A CRITERIA
	REVERSE DBLE CURV & MEDIUM TWIST 	LESS THAN 0.04	LESS THAN 0.16	LESS THAN 30 DEGS		
C	LARGE DOUBLE CURVATURE 	MORE THAN 0.04	MORE THAN 0.16	0 ↓ 30 DEGS	ROLLER OR PRESS THEN LINE HEATING SPECIAL TEMPLATES REQUIRED TO ENSURE CORRECT FORMING	SPLIT INTO A NUMBER OF SMALLER PLATES EACH WITHIN CLASS A CRITERIA
	LARGE REVERSE DOUBLE CURVATURE 					
	EXCESSIVE TWIST 	ALL THE ABOVE	ALL THE ABOVE	MORE THAN 30 DEGS	LINE HEATING ONLY	SPLIT INTO TWO PLATES BY PROVIDING BUTT AT SURFACE INFLECTION

NOTE - WHENEVER POSSIBLE DEFINE SHELL PLATES TO BE CLASS A PLATES

5.4 Addition of Butts to Aid Shell Plate Development and Forming

Dividing shell plates with excessive curvature and/or twist into smaller plates has already been mentioned as a way to avoid unacceptable plates. When a shell plate, as defined by the ship designer, has both a hump and a hollow it is necessary to divide the plate into two plates as shown in Figure 5.4.1. The additional butt should be located at the curvature inflexion.

Another situation where additional butts are required is in way of plates that cross the flat of side or bottom tangent lines where they are curved. These plates may appear simple to handle but experience has shown that they are problem plates. This is because the curved part beyond the tangent line requires the complex curvature development, whereas the flat part does not and the interface is distorted. That is the flat part is stretched by the curved part and the resulting development can have unacceptable gaps between the seams. This problem can be avoided if additional butts are located in the flat part of the plate near to the tangent line as shown in Figure 5.4.2.

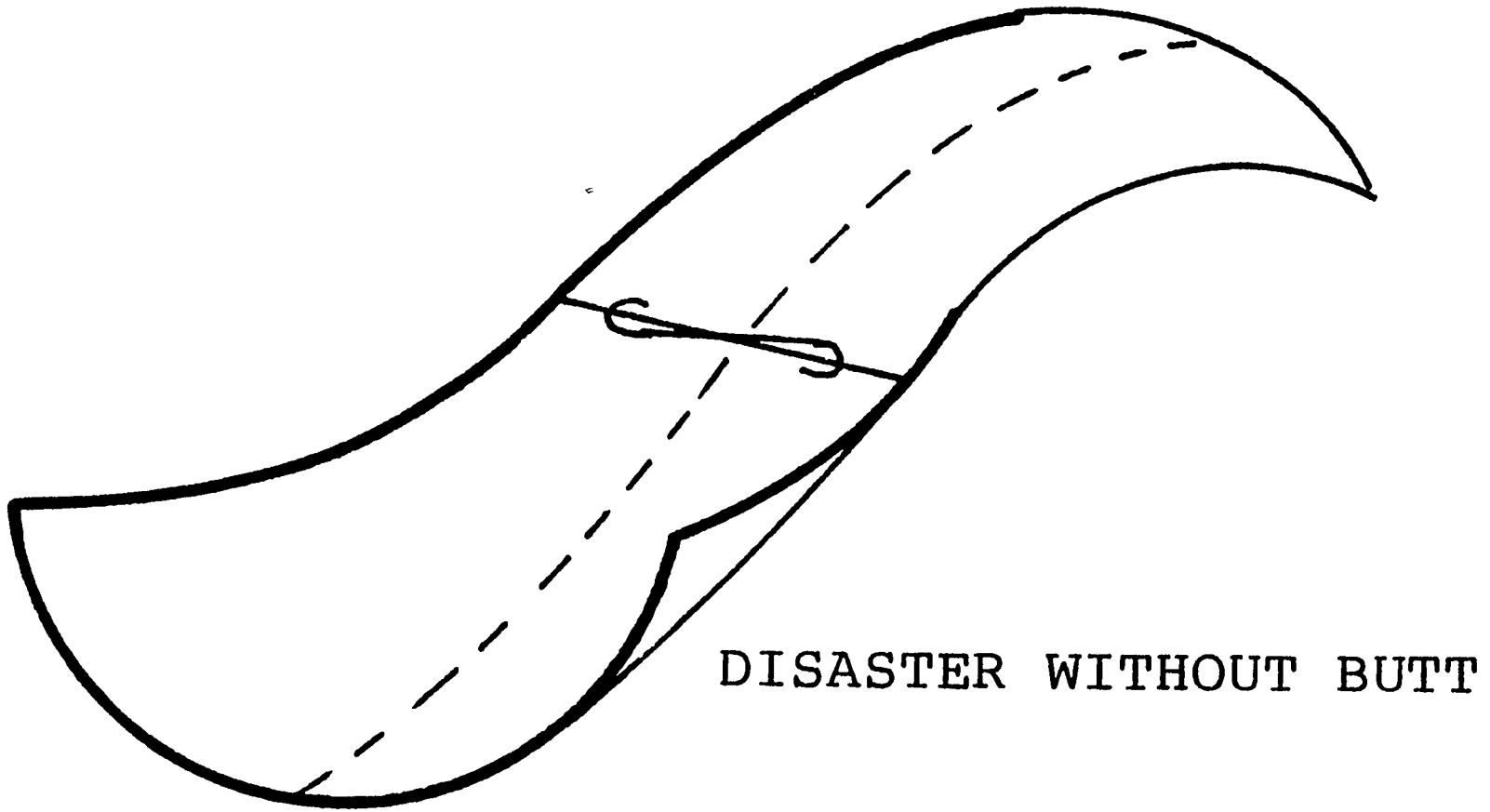
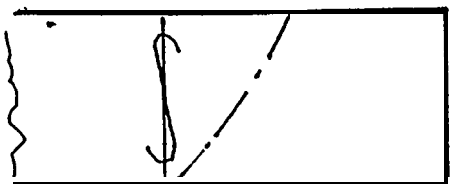
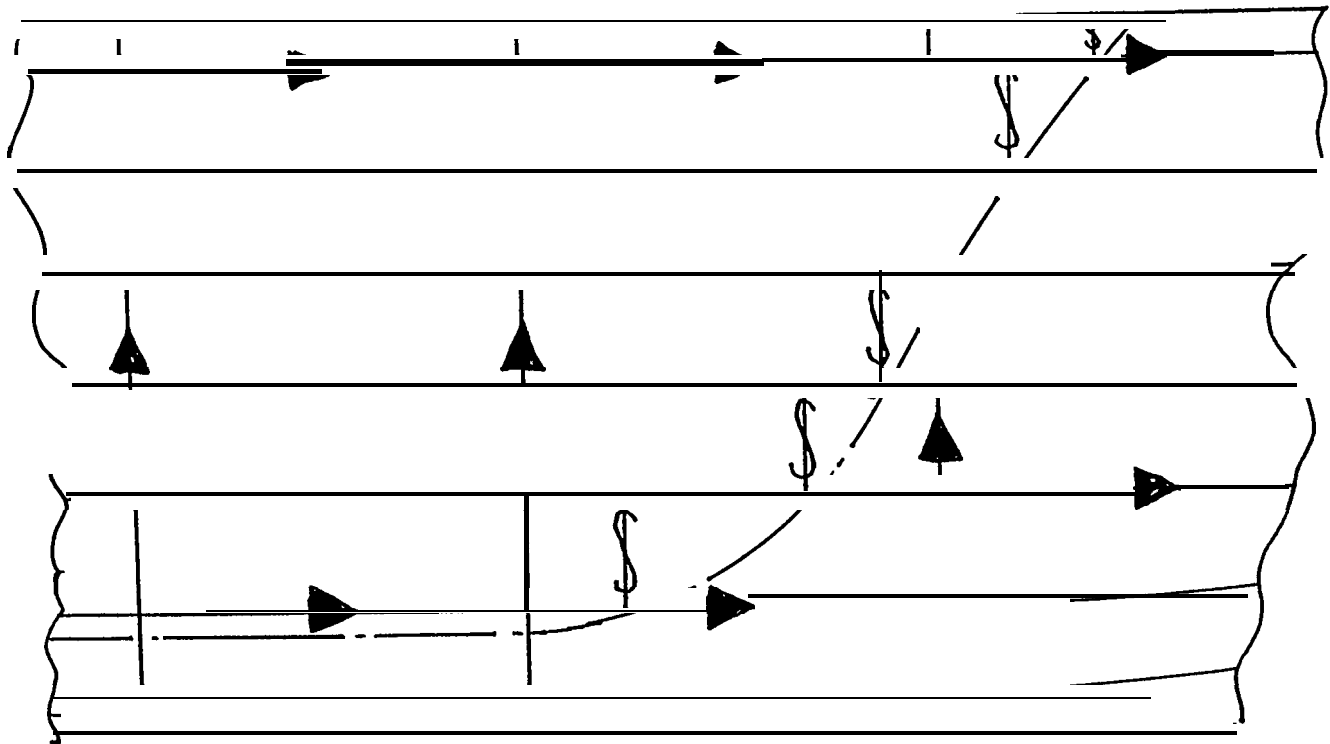

FIGURE 5.4.1 - PLATE WITH BOTH DOUBLE AND REVERSE DOUBLE CURVATURE



NEED BUTT IF TANGENT
LINE IS CURVED



DO NOT NEED BUTT IF TANGENT
LINE IS VERY CLOSE TO STRAIGHT LINE

FIGURE 5.4.2 - ADDITIONAL BUTTS IN WAY OF FLAT TANGENT LINE

6.0 CLOSURE

The proposed approach to analyzing and preparing lines and shell plate definition will involve some additional design effort but it is not expected to be more than 1000 man hours for a typical large commercial ship.

Is this effort worthwhile?

It is estimated that the reduction in production manhours, for the typical ship, due to easier forming and erecting of the structure would be in the order of 8000 manhours. This on its own would seem a reasonable trade off and incentive to undertake the approach. However, the resulting reduction in ship cost would be only about \$160,000. For a \$120 million ship this is only 0.13%. This small overall saving may not be considered worthwhile when viewed in this light. However, there is another aspect of competitiveness that must be taken into account and that is building time. The erection of the structure is on the critical path and any reduction in erection time will improve this important factor.

It is anticipated that the approach could reduce the erection time by one to two months. Two months off a 24 month design and build cycle is an 8% improvement and definitely would be worthwhile in the quest toward international competitiveness.

Even if there is no deliberate decision by a shipyard to use the ideas presented in this guide it is still the responsibility of every designer to develop “production friendly” designs. If this guide helps any designer to improve in this aspect, through an awareness of the matter, then it will have accomplished its purpose.

Additional copies of this report can be obtained from the National Shipbuilding Research Program Coordinator of the Bibliography of Publications and Microfiche Index. You can call or write to the address or phone number listed below.

NSRP Coordinator

The University of Michigan
Transportation Research Institute
Marine Systems Division
2901 Baxter Road
Ann Arbor, MI 48109-2150
Phone: (313) 763-2465
Fax: (313) 936-1081