

Dynamic Locomotion with One, Four and Six-Legged Robots

Martin Buehler

Ambulatory Robotics Laboratory (ARL), Centre for Intelligent Machines, McGill University
Montreal, Quebec, Canada, H3A 2A7, www.cim.mcgill.ca/~arlweb

1 Introduction

This paper surveys the research in dynamically stable legged locomotion in our lab over the past ten years. Our robots share a reliance on the passive dynamics of their suitably designed dynamical system, low degree-of-freedom electric actuation coupled with a minimalistic approach to mechanical complexity, radially compliant leg designs which decouple the actuators from gravitational loads, minimal reliance on complex feedback-based controllers, a complete system design approach for dynamic mobility and autonomy, and increasingly, biological inspiration. Our one, four and six-legged running robots exemplify these fundamental design and control principles, which are critical to their success, measured in terms of stability, energy efficiency and speed.

For any mobile robot to be of practical utility, it must be able to operate without tether for a sufficient amount of time, where ‘sufficient’ is determined by the particular application, and can mean anywhere from ½ hour to days. Dynamic legged robots already face a multitude of design and operational constraints arising from the under-actuated nature of their dynamics, the limited horizontal ground force to avoid slipping, the small stance times during which control can be applied, the limited bandwidth of control that can be applied due to series compliances necessary for transient energy storage, and the limited power and energy densities of commercial actuators. When adding the need for power autonomy based on low energy density batteries, it becomes clear that a successful legged robot must be designed as a complete system from the beginning, taking into account realistic models of actuators, that will, almost by definition, operate at their limits of performance and will thus effect the types of controllers that can be applied.

Similarly, required runtime based on energy efficiency cannot be an afterthought, but must be taken into account at the robot’s design stage, based on a knowledge of the

required dynamic regimes. An increasingly accepted measure of energy efficiency is the ‘specific resistance’ – a measure proposed originally by Gabrielli and von Karman [1] in 1950,

$$\varepsilon(v) = \frac{P(v)}{mgv}$$

where P is the average power expenditure, m is the total mass of the vehicle, g is the gravitational acceleration, and v is the forward speed.

2 One-legged hopping: ARL Monopods

The classical system to study dynamic robot locomotion has been the one-legged hopping robot, featuring a single, compliant prismatic leg. Early experiments by Matsuoka [2] were based on this system. Subsequently, about 20 years ago, Raibert [3] began his pioneering research on running robots, and developed one-, two- and four-legged running robots, whose performance is still largely unsurpassed and forms the yardstick by which robots are still measured today.

His first monopods provided proof of the basic principles at work – the importance of properly built mechanical systems that support the desired motion, symmetry of motion, the decoupled three-part control of hopping height, body pitch, and forward speed, and the ability to generalize these principles to multi-legged robots.

Despite the limited practical utility of monopods, the presence of a basic spring loaded inverted pendulum dynamics in robots with multiple legs, with articulated legs, as well as in humans and a large number of animals across a wide range of size and weight, with various number of legs and complex leg morphology [4], have made monopods the system of choice to study dynamically stable legged locomotion [5,6,7].

Our work has primarily been inspired by Raibert’s ground breaking work. Our focus was the development of robot

Report Documentation Page

*Form Approved
OMB No. 0704-0188*

Public reporting burden for the collection of information is estimated to average 1 hour per response, including the time for reviewing instructions, searching existing data sources, gathering and maintaining the data needed, and completing and reviewing the collection of information. Send comments regarding this burden estimate or any other aspect of this collection of information, including suggestions for reducing this burden, to Washington Headquarters Services, Directorate for Information Operations and Reports, 1215 Jefferson Davis Highway, Suite 1204, Arlington VA 22202-4302. Respondents should be aware that notwithstanding any other provision of law, no person shall be subject to a penalty for failing to comply with a collection of information if it does not display a currently valid OMB control number.

1. REPORT DATE 2005	2. REPORT TYPE	3. DATES COVERED -			
4. TITLE AND SUBTITLE Dynamic locomotion with One, Four and Six-Legged Robots		5a. CONTRACT NUMBER			
		5b. GRANT NUMBER			
		5c. PROGRAM ELEMENT NUMBER			
6. AUTHOR(S)		5d. PROJECT NUMBER			
		5e. TASK NUMBER			
		5f. WORK UNIT NUMBER			
7. PERFORMING ORGANIZATION NAME(S) AND ADDRESS(ES) Defense Advanced Research Projects Agency, 3701 North Fairfax Drive, Arlington, VA, 22203-1714		8. PERFORMING ORGANIZATION REPORT NUMBER			
9. SPONSORING/MONITORING AGENCY NAME(S) AND ADDRESS(ES)		10. SPONSOR/MONITOR'S ACRONYM(S)			
		11. SPONSOR/MONITOR'S REPORT NUMBER(S)			
12. DISTRIBUTION/AVAILABILITY STATEMENT Approved for public release; distribution unlimited					
13. SUPPLEMENTARY NOTES The original document contains color images.					
14. ABSTRACT see report					
15. SUBJECT TERMS					
16. SECURITY CLASSIFICATION OF:			17. LIMITATION OF ABSTRACT	18. NUMBER OF PAGES	19a. NAME OF RESPONSIBLE PERSON
a. REPORT unclassified	b. ABSTRACT unclassified	c. THIS PAGE unclassified		6	

designs and controllers for stable running with power autonomy based on standard electric actuation, instead of tethered, powerful hydraulic actuation. Our planar ARL Monopod I [8,9] demonstrated that by designing the dynamical system, including the compliance, actuator and transmission models, as well as the operating modes in the design process from the beginning, it was possible to achieve dynamically stable locomotion based on electric motors, despite drastically reduced actuator power and energy densities. ARL Monopod I was able to run at up to 1.2 m/s with a specific resistance of 0.7 based on an average mechanical power of 125 W at 1.2 m/s. While the speed and body pitch controllers were similar to Raibert's, we developed a new thrusting controller during stance, based on the motor's scaled torque-speed curve [9]. This controller was exactly implementable, transferred sufficient energy during the short stance phase of approx. 0.2 s and stabilized the hopping height over the full speed range.

A detailed energetic analysis of these experimental results [9] showed that just swinging the leg cost 40% of the total mechanical energy at top speed. Yet much of this energy can be saved by introducing a series compliance in the hip and relying on a properly sustained body-leg counter-oscillation to swing the leg. A stable and robust running controller for such a system was proposed in [10], and ARL Monopod II (Fig. 1) was constructed to exploit these potentially drastic energy savings. Like the previous version, it consisted of a body connected to a compliant prismatic leg at the hip joint, and was constrained to move in a vertical plane. It was about 0.7 m tall and weighs 18 kg. The system now had a total of seven degrees of freedom, but due to kinematic constraints, not all of them are free simultaneously. During stance there are five degrees of freedom and during flight there are six. Both the hip and leg actuators are connected in series with the springs. With only two actuator inputs - the hip and leg motor torques – the system is highly under-actuated.

Running is a combination of two synchronized oscillations, the vertical hopping motion and the counter-oscillations of the leg and body about the hip via the hip spring. With proper initial conditions, the robot can hop for a few steps completely un-actuated, before it falls. This running motion is unstable, but is produced entirely by the robot's passive dynamics. It can be stabilized via minimal actuator effort to compensate for the losses and errors. The CPDR strategy [11] calculates the ideal passive joint trajectories for any given forward speed and uses them as the nominal input reference trajectories to the joint controllers for tracking. The two control tasks are synchronized by expressing the trajectories in terms of "Locomotion Time" η (Fig. 2) which re-scales time such that stance and flight times are mapped onto a fixed interval on the real line. As long as the speed changes are

gradual, and during steady state running, the desired leg angle trajectory is close to passive hip-leg oscillation and tracking the reference trajectory can readily be achieved by a model based controller.

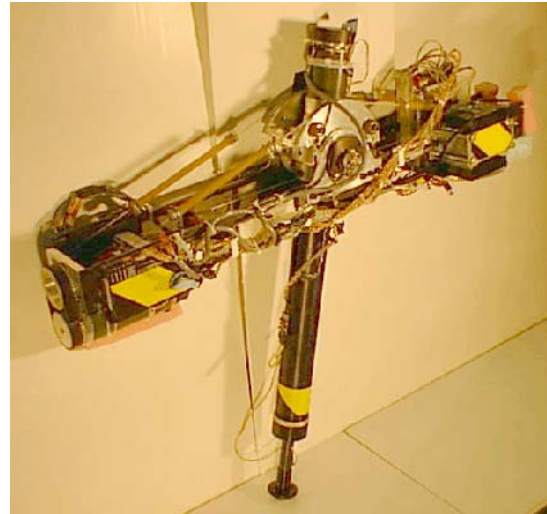

Figure 1: ARL Monopod II

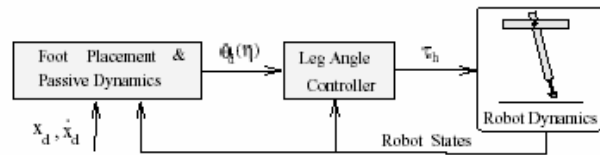

Figure 2: Velocity controller

Hopping height was controlled precisely to within 1 cm via a new adaptive energy-based feedback controller. Implementation of Controlled Passive Dynamic Running permits running at up to 1.2 m/s with a total mechanical power expenditure of only 48 W, which translates into a specific resistance (based on mechanical power expenditure only) of only 0.22, a reduction of almost 70% from the specific resistance of ARL Monopod I with directly actuated hip [11].

3 Four-legged locomotion: Scout I, II

The ARL Monopods showed the feasibility of dynamically stable robots with fewer actuators than degrees of freedom that move fast and efficiently based on standard electric actuators. How could these properties be extended to more practical quadruped robots? In order to further enhance practical utility, we are interested in minimally complex mechanical systems, by virtue of their potential for lower cost, lower weight, and higher robustness.

To explore the limits of simplicity, we pursued the design and control of a prototype quadruped, Scout I, with stiff legs, and only one actuator per leg, located at the hip joint [12,13] (Fig. 3). The resulting lack of the legs' kinematic dexterity was compensated by a dynamically dextrous mode of operation - the robot walks by rocking back and forth. Surprisingly, stable dynamic walking was achieved by a controller that matched the simplicity of the robot – with the front legs stationary, the back legs touch down at a fixed angle and sweep a fixed distance as well. The resulting controller requires only one actuator for the entire robot (driving both back legs) for walking in the sagittal plane and only touchdown sensing and hip motor control. Full planar mobility on flat floors and dynamic step climbing up to 45% of leg length was demonstrated successfully on this platform. A numerical Poincaré analysis based on experimental data confirmed local fixed point stability and showed a large domain of attraction [13].

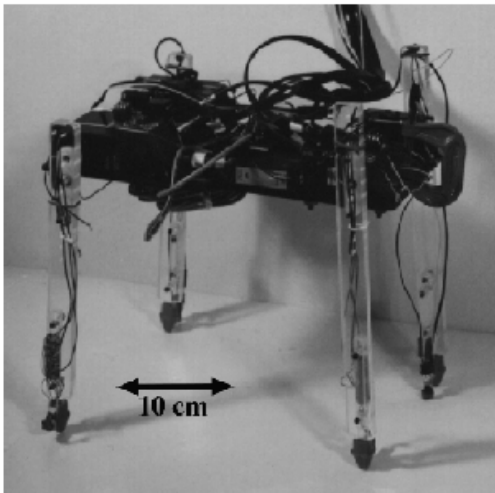

Fig. 3: Scout I

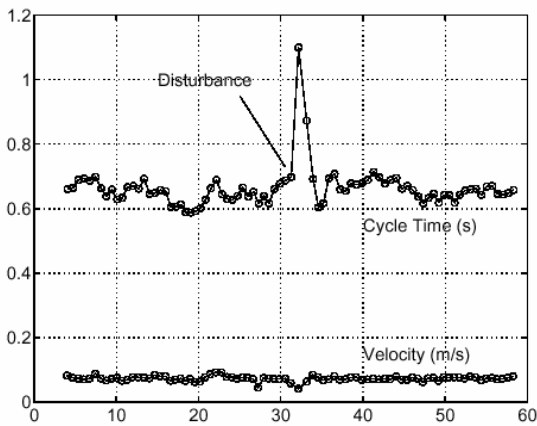

Fig. 4: Scout I stable experimental performance with open loop ramp controller (from [12]).

Could the somewhat radical single-actuator-per-leg paradigm that enabled Scout I to walk dynamically with stiff legs, be extended successfully to quadruped running with compliant legs? The positive answer to this question was demonstrated by the larger and un-tethered Scout II.

Scout II has been designed from the ground up for autonomous operation: The two hip assemblies contain the actuators and batteries, and the body houses all computing, interfacing and power distribution. The mechanical design (Fig. 5) is an exercise in simplicity. Besides its modular design, the most striking feature inherited from Scout I is the fact that it uses a single actuator per leg – the hip joint provides leg rotation in the sagittal plane. Each leg assembly consists of a lower and an upper leg, connected via a spring to form a compliant prismatic joint. Thus each leg has two degrees of freedom, one actuated hip and one un-actuated radial compliance.

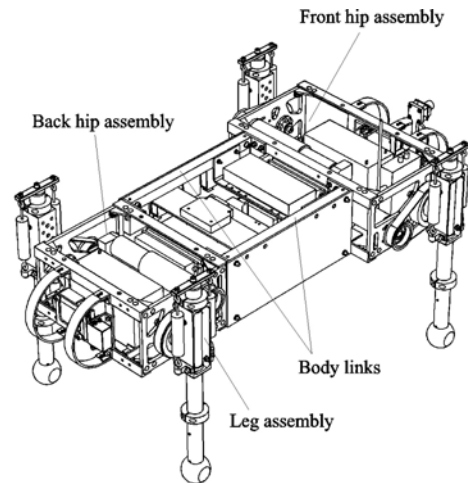

Figure 5: Scout II

Like most running robots, Scout II is an under-actuated, highly nonlinear, intermittent dynamical system. Despite this complexity, we find consistently, just like Raibert did, that simple control laws can stabilize periodic motions, resulting in robust and fast running. Surprisingly, some controllers do not require task level feedback like forward velocity, or body angle. What is more, there seem to exist many such simple stabilizing controllers – in [14] three variations are introduced. It is remarkable that the significant controller differences have relatively minor effects on bounding performance! For this reason and for brevity we shall describe one of these controllers here.

The controller is based on two individual, independent leg controllers, without a notion of overall body state. The front and back legs each detect two leg states - stance (touching ground) and flight (otherwise), which are separated by touchdown and lift-off events. There is no

actively controlled coupling between the fore and hind legs – the resulting bounding motion is purely the result of the controller interaction through the multi-body dynamic system. During flight, the controller servos the flight leg to a desired touchdown hip angle, ϕ_{td} then sweeps the leg during stance until a sweep limit, ϕ_{sl} is reached. In stance phase, a constant torque of 35 Nm is commanded at the hip until the sweep limit is reached. Then a PD controller controls the hip angle at the sweep limit angle. Even though we show only the results for one of several controllers implemented, experimental performance for all of them is very similar – resulting in stable and robust bounding, at top speeds between 0.9 and 1.2 m/s (Fig. 6). Stable pronking gaits can also be achieved by simply changing the touchdown and sweep limit set points. Specific resistance of 0.3 during bounding at 1.2 m/s is close to that of ARL Monopod II (Fig. 7).



Figure 6: Illustration of a bounding gait (left) and Scout II bounding (right).

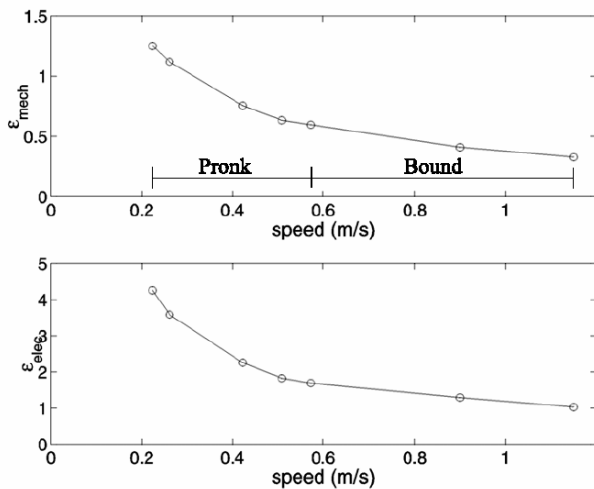

Fig. 7: Specific resistance as a function of forward speed based on mechanical (top) and total electrical (bottom) power consumption.

4 Six-legged locomotion: RHex

The design and control of RHex (Fig. 8) was inspired by recent research in biology [4,15]– in particular cockroach locomotion. The RHex research group (at McGill, UC Berkeley, U. Michigan, and recently Carnegie Mellon University) has successfully captured some of the key biomimetic functions [16] in the simple RHex morphology. This has imbued RHex with outstanding mobility over many types of terrain [17,18].



Figure 8: RHex in rough terrain and on stairs.

As in Scout II, the body contains all elements for autonomous operation, including computing, I/O, sensing, actuation, and batteries. Unlike most six-legged robots built to date, RHex has compliant legs, and was built to be a runner. Each leg has, again, only one actuator located at the hip and rotates in the sagittal plane. Even though the leg design does not use a prismatic joint, it is designed to act largely like a radial compliance, by virtue of its structural, distributed leg compliance. RHex walks with a compliant tripod gait, and eliminates toe clearance problems by rotating the legs in a full circle.

Since the present prototype robot has no external sensors by which its body coordinates may be estimated, we have used joint space closed loop (“proprioceptive”) but task space open loop control strategies. These are tailored to demonstrate the intrinsic stability properties of the compliant hexapod morphology and emphasize its ability to operate without a sensor-rich environment. Specifically, we employ a four-parameter family of controllers that yields stable walking, running and turning of the hexapod on varied terrain, without explicit enforcement of quasi-static stability. All controllers generate periodic desired trajectories for each hip joint, which are then enforced by six local PD controllers, one for each hip actuator. As such, they represent examples near one extreme of possible control strategies, which range from purely open-loop controllers to control laws that are solely functions of the leg and rigid body state. It is evident that neither one of these extremes is the best approach and a combination of these should be adopted. An alternating tripod pattern governs both the running and turning controllers, where

the legs forming the left and right tripods are synchronized with each other and are 180° out of phase with the opposite tripod, as shown in Fig. 9.

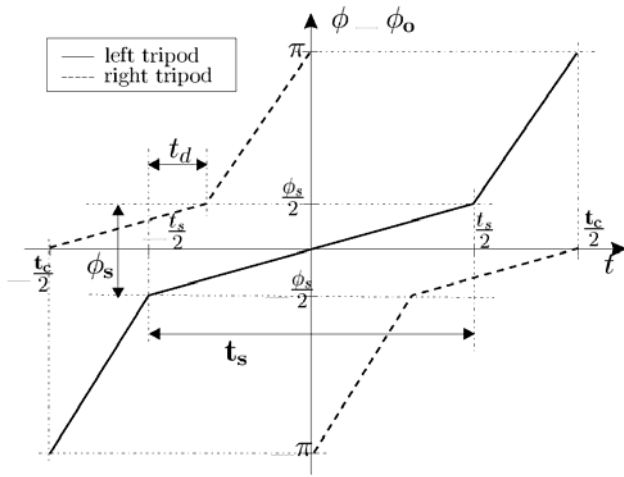

Figure 9: Motion profiles for left and right tripods.

The running controller's target trajectories for each tripod are periodic functions of time, parametrized by four variables: t_c , t_s , ϕ_s and ϕ_0 . The period of both profiles is t_c . In conjunction with t_s , it determines the duty factor of each tripod. In a single cycle, both tripods go through their slow and fast phases, covering ϕ_s and $2\pi - \phi_s$ of the complete rotation, respectively. The duration of double support t_d , when all six legs are in contact with the ground, is determined by the duty factors of both tripods. Finally, the ϕ_0 parameter offsets the motion profile with respect to the vertical. Note that both profiles are monotonically increasing in time; but they can be negated to obtain backward running.

To date, RHex has demonstrated one of the key advantages of legged systems over other types of mobile platforms: versatility. The tripod gait with its four parameters described above enables RHex to traverse a large variety of obstacles, and move over rugged and highly fractured terrain [18] at speeds of one body length per second. A waterproof prototype has demonstrated swimming based on the same tripod gait. New gait patterns enable it to pronk with a flight phase [19] and climb varied, full size stairs, including 42 degree steep fire escape stairs [20,21]. Ongoing research aims at leaping, fast running gaits, improvements in runtime beyond the current maximum of one hour.

5 Conclusion

Research in legged robots over the past four decades and in dynamically stable legged robots over the past two decades has produced a wealth of design and control

paradigms and an impressive variety of experimental prototypes with one, two, four, six and eight legs. The research described in this article represents but a tiny fraction of this exciting field. Our research focused on legged robots with minimal mechanical complexity, which, by virtue of their dynamical dexterity, suitably designed unforced dynamics, biological inspiration, and a complete system design approach, can rival the mobility, speed, energy efficiency and overall performance of more complex systems.

Acknowledgements

The ARL Monopod and Scout projects were supported by NSERC (The Natural Sciences and Engineering Research Council of Canada) and IRIS (Institute for Robotics and Intelligent Systems, A Federal Network of Centers of Excellence of Canada). The RHex work is supported by DARPA/SPAWAR contract N66001-00-C-8026. The author would like to thank all his past and present graduate students for their contributions to the research on which this article is based, and all the RHex team members at McGill – at U. Michigan (Prof. D. Koditschek and his students) – at Carnegie Mellon University (Dr. A. Rizzi and his team), and Prof. R. J. Full at UC Berkeley, for all their contributions that made this research possible, and for providing a stimulating and supportive research environment.

References

- [1] G. Gabrielli and T. H. von Karman, "What price speed?" *Mechanical Engineering*, vol. 72, no. 10, 1950
- [2] K. Matsuoka, "A mechanical model of repetitive hopping movements", *Biomechanisms*, Vol 5, pp. 251-258, 1980.
- [3] M. H. Raibert, *Legged Robots that Balance*, MIT Press, Cambridge, MA, 1986.
- [4] R. Blickhan and R. J. Full, "Similarity in multilegged locomotion: bouncing like a monopode", *J. Comparative Physiology*, vol. A. 173, pp. 509-517, 1993.
- [5] U. Saranli, W. J. Schwind, and D. E. Koditschek, "Toward the Control of a Multi-Jointed, Monoped Runner," *IEEE Int. Conf. Robotics and Automation*, Leuven, Belgium, May 1998.
- [6] W. J. Schwind and D. E. Koditschek, "Approximating the Stance Map of a 2 DOF

- Monoped Runner," *J. Nonlinear Science*, to appear.
- [7] D. E. Koditschek and M. Buehler, "Analysis of a Simplified Hopping Robot," *Int. J. Robotics Research*, 10(6):587-605, Dec 1991.
- [8] H. Rad, P. Gregorio, and M. Buehler, "Design, Modeling and Control of a Hopping Robot," *IEEE/RSJ Conf. Intelligent Robots and Systems*, p. 1778-1785, Yokohama, Japan, Jul 1993.
- [9] P. Gregorio, M. Ahmadi, and M. Buehler, "Design, Control, and Energetics of an Electrically Actuated Legged Robot," *IEEE Transactions on Systems, Man, and Cybernetics*, 27B(4):626-634, Aug 1997.
- [10] M. Ahmadi and M. Buehler, "Stable Control of a Simulated One-Legged Running Robot with Hip and Leg Compliance," *IEEE Trans. Robotics and Automation*, 13(1):96-104, Feb 1997.
- [11] M. Ahmadi and M. Buehler, "The ARL Monopod II Running Robot: Control and Energetics," *IEEE Int. Conf. Robotics and Automation*, p. 1689-1694, May 1999.
- [12] M. Buehler et al, "SCOUT: A Simple Quadruped that Walks, Climbs, and Runs", *IEEE Int. Conf. Robotics and Automation*, pp. 1701-1712, 1998.
- [13] M. Buehler, A. Cocosco, K. Yamazaki, and R. Battaglia, "Stable Open Loop Walking in Quadruped Robots with Stick Legs," *IEEE Int. Conf. Robotics and Automation*, p. 2348-2353, Detroit, Michigan, May 1999.
- [14] D. Papadopoulos and M. Buehler, "Stable Running in a Quadruped Robot with Compliant Legs," *IEEE Int. Conf. Robotics and Automation*, April 2000.
- [15] R. J. Full, K. Autumn, J. I. Chung, and A. Ahn, "Rapid negotiation of rough terrain by the death-head cockroach," *American Zoologist*, vol. 38, pp. 81A, 1998.
- [16] R. Altendorfer, N. Moore, H. Komsuoglu, M. Buehler, H. B. Brown Jr., D. McMordie, U. Saranli, R. Full, D. E. Koditschek, "RHex: A Biologically Inspired Hexapod Runner," *Autonomous Robots* 11 (2001) 207-213.
- [17] U. Saranli, M. Buehler and D. E. Koditschek, "Design, Modeling and Preliminary Control of a Compliant Hexapod Robot", *IEEE Int. Conf. Robotics and Automation*, pp. 2589-2596, 2000.
- [18] U. Saranli, M. Buehler, and D. E. Koditschek, "RHex: A Simple and Highly Mobile Hexapod Robot," *Int. J. Robotics Research*, 20(7):616-631, July 2001.
- [19] D. McMordie and M. Buehler, "Towards Pronking with a Hexapod Robot", 4th Int. Conf. on Climbing and Walking Robots, Karlsruhe, Germany, September 24 – 26, 2001.
- [20] E.Z. Moore and M. Buehler, "Stable Stair Climbing in a Simple Hexapod", 4th Int. Conf. on Climbing and Walking Robots, pp. 603-610, 2001.
- [21] E. Z. Moore, D. Campbell, F. Grimmering, and M. Buehler, "Reliable Stair Climbing in the Simple Hexapod 'RHex'," *IEEE Int. Conf. Robotics and Automation*, (in press), 2002.