

DTIC FILE COPY

90-24

SPECIAL REPORT

AD-A226 278

Thermistor-Based Thermal Conductivity Measurement System

Ronald T. Atkins and Edmund A. Wright

June 1990

DTIC
ELECTE
AUG 30 1990
S E D
Co

DISTRIBUTION STATEMENT A
Approved for public release;
Distribution Unlimited

90 08 29 040

For conversion of SI metric units to U.S./British customary units of measurement consult ASTM Standard E380, Metric Practice Guide, published by the American Society for Testing and Materials, 1916 Race St., Philadelphia, Pa. 19103.



**U.S. Army Corps
of Engineers**
Cold Regions Research &
Engineering Laboratory

Thermistor-Based Thermal Conductivity Measurement System

Ronald T. Atkins and Edmund A. Wright

June 1990

Accession For	
NTIS GRA&I	<input checked="" type="checkbox"/>
DTIC TAB	<input type="checkbox"/>
Unannounced	<input type="checkbox"/>
Justification	
By _____	
Distribution/	
Availability Codes	
Dist	Avail and/or Special
A-1	



Prepared for
ALASKA DEPARTMENT OF TRANSPORTATION
AND PUBLIC FACILITIES

Approved for public release; distribution is unlimited.

PREFACE

This report was prepared by Ronald T. Atkins, Chief, Technical Services Division, and Edmund A. Wright, Technical Publications Writer-Editor, Technical Communication Branch, Information Management Division, U. S. Army Cold Regions Research and Engineering Laboratory. Initial funding for this project was provided by the Alaskan Department of Transportation and Public Facilities.

The contents of this report are not to be used for advertising or promotional purposes. Citation of brand names does not constitute an official endorsement or approval of such commercial products.

CONTENTS

Abstract	ii
Preface	iii
Introduction	1
Theory	1
Calibration	4
Measurement	4
Measurement procedures	4
Typical measurement	5
Example: Test material: dry silt	6
Thermistor thermometry	7
Typical results	7
Discussion of results	10
Conclusions and recommendations	11
Literature cited	11

ILLUSTRATIONS

Figure

1. Typical glass bead thermistor configuration	2
2. Thermal conductivity probe	4
3. Three possible circuit configurations	5
4. Thermal conductivity tests, Fairbanks silt	8
5. Thermal conductivity of Lebanon, N.H., water treatment sludge	9
6. Thermal conductivity of West Lebanon, N.H., return activated sludge	9
7. Thermal conductivity of Woodstock, Vt., return activated sludge	9
8. Thermal conductivity of Hanover, N.H., digested primary sludge	9
9. Thermal conductivity of Watervliet Arsenal chrome sludge	10
10. Thermal conductivity of Watervliet Arsenal oily sludge	10

TABLES

Table

1. Calibration data for one of the three thermistors	7
2. Results of the tests on Fairbanks silt	8
3. Results of the tests on 2-in. blue foam insulation	8

Thermistor-Based Thermal Conductivity Measurement System

RONALD T. ATKINS AND EDMUND A. WRIGHT

INTRODUCTION

The original intent of the work described in this report was to develop a method for measuring point thermal conductivities that uses inexpensive sensors readily available from commercial sources, requires no specialized instruments, gives reasonably accurate measurements of thermal conductivities, can be checked using readily available "standard materials," and is field operable. The only specific restrictions on the use of this method for thermal conductivity measurements are that 1) there must be sufficient material to ensure that measurements are taken in a large volume compared to the volume of the thermistor, 2) the material must have a reasonably uniform temperature distribution and be relatively stable in temperature during the measurement interval (about 10 minutes), and 3) the grain size of the material must be small enough to ensure that intimate thermal contact is maintained over the entire surface of the thermistor.

A number of other studies (e.g., Hayes and Valvano 1985, Dougherty 1987a,b and Nieto de Castro 1988) have developed techniques that use thermistors for determination of thermal conductivity. All these methods require the use of specialized equipment specifically dedicated to the measurement of thermal conductivity. However, the methodology described in this report differs from all others in that it uses only readily available, inexpensive equipment and that a time measurement is not necessary for calculation of the thermal conductivity values.

Examples of materials for which this thermal conductivity measurement technique is appropriate are fine-grained soils, building materials such as polystyrene, gel-like materials such as silicone grease, and fiberglass insulations. This measurement technique was awarded a U.S. Patent (Patent 4,522,512) on 11 June 1985; however, there are no restrictions on its use. Throughout this report thermal conductivity measurements are reported in calories per square centimeter per centimeter per second per degree Celsius (cal/cm-s, or cal/cm-s-°C). To convert these values to BTU per square foot per inch per hour per degree Fahrenheit (BTU/ft²-in.-hr-°F) divide by 3.44×10⁻⁴.

THEORY

Assume that a thermistor is a perfect sphere embedded in a material such as is shown in Figure 1. When the thermistor's semiconductor bead is heated slightly (electrically) the steady-state heat flow equation (e.g., Kreith 1961) into the glass envelope is

$$Q = K_t \sqrt{A_0 A_1} \frac{T_0 - T_1}{R_1 - R_0} \quad (1)$$

where Q = thermal energy being generated in the semiconductor bead
 K_t = thermal conductivity of the glass envelope of the thermistor
 A_0 = surface area of the semiconductor sphere
 A_1 = surface area of the glass sphere
 T_1 = surface temperature of the glass sphere

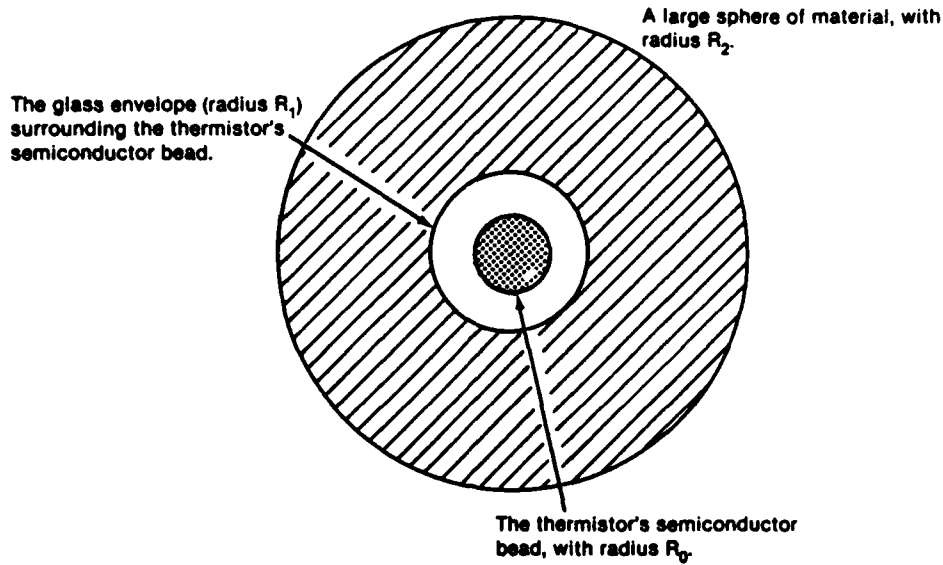

Figure 1. Typical glass bead thermistor configuration.

- T_0 = surface temperature of the semiconductor bead
- R_0 = radius of the semiconductor bead (sphere)
- R_1 = radius of the glass bead (sphere).

Since the surface area of a sphere is $4\pi R^2$, eq 1 can be written as

$$Q = K_1 4\pi (T_0 - T_1) \frac{R_1 R_0}{R_1 - R_0} \quad (2)$$

If the sphere of test material is assumed to completely surround the glass sphere of the thermistor, then at steady state the thermal energy flowing into the glass bead can be assumed to flow on into the material, so that

$$Q = K_m 4\pi (T_1 - T_2) \frac{R_2 R_1}{R_2 - R_1} \quad (3)$$

- where K_m = thermal conductivity of the material
- T_2 = temperature of the surface of the sphere of material
- R_2 = radius of the sphere of material.

Solving eq 3 for the thermal conductivity of the material, K_m

$$K_m = \frac{Q}{4\pi(T_1 - T_2)} \left(\frac{1}{R_1} - \frac{1}{R_2} \right)$$

If the volume of material is so large that the radius R_2 can be assumed to be infinite with respect to R_0 and R_1

$$K_m = \frac{Q}{4\pi R_1 (T_1 - T_2)} \quad (4)$$

This equation can be used to find the thermal conductivity of the material provided a means can be found to find a value for T_1 (the surface temperature of the glass envelope). This means is provided by eq 2, which, when solved for T_1 , gives

$$T_1 = T_0 - \frac{Q(R_1 - R_0)}{K_1 4\pi R_0 R_1}.$$

When the thermistor is heated, the value of Q can be found by

$$Q = 0.2389 I^2 R_{\text{hot}}$$

where I = current in the thermistor

R_{hot} = resistance of the thermistor when it is heated

Q = heat flow in calories per second.

In theory, then, a thermistor can be used to measure the thermal conductivity of a bulk material by using the following three equations:

$$Q = 0.2389 I^2 R_{\text{hot}}$$

$$T_1 = T_0 - \frac{Q(R_1 - R_0)}{K_1 4\pi R_0 R_1}.$$

$$K_m = \frac{Q}{4\pi R_1 (T_1 - T_2)}.$$

For any given thermistor the values of R_0 , R_1 and K_1 will all be constants. Therefore, the second equation can be written as

$$T_1 = T_0 - AQ$$

where

$$A = \frac{R_1 - R_0}{K_1 4\pi R_0 R_1}.$$

This equation can then be substituted in the third equation so that

$$K_m = \frac{BQ}{T_0 - AQ - T_2}$$

where

$$B = \frac{1}{4\pi R_1}$$

or

$$K_m [(T_0 - T_2) - AQ] = BQ. \quad (5)$$

This equation can be used to calibrate a thermistor that can then be used to measure the thermal conductivity of a material. All that is needed is to solve for A and B by using two materials whose thermal conductivities are known and measuring the Q , T_0 and T_2 associated with those materials.

T_2 is the "unheated" temperature of the material and is found by measuring the temperature of the material before heating the thermistor, using standard thermistor-temperature measurement techniques. T_0 is found by measuring the heater current to the thermistor and the voltage across it. This is simplified to just a voltage measurement if a known constant current is used to heat the thermistor. Since both

the current and the voltage of the heated thermistor are known, its resistance is known (by Ohm's law) and, therefore, the temperature T_0 of the semiconductor bead. Q is the heater current times the voltage across the thermistor times 0.2389:

$$Q = 0.2389 I \cdot V$$

or by Ohm's law,

$$Q = 0.2389 I^2 R.$$

The complete technique for using a thermistor to measure bulk thermal conductivity is therefore as follows.

Calibration

1. Measure Q , T_0 and T_2 for the thermistor in each of two materials whose thermal conductivity is known.
2. Use these values to solve for A and B in the equation

$$K_m [(T_0 - T_2) - AQ] = BQ \quad (6)$$

using standard two equation-two unknowns techniques.

Measurement

1. With A and B known, place the thermistor in an unknown material and measure Q , T_0 and T_2 .
2. Calculate the thermal conductivity using

$$K_m = \frac{BQ}{(T_0 - T_2) - AQ} \quad (7)$$

All measurements must be taken during a thermally steady-state condition. This condition is determined by monitoring the voltage across the thermistor. When the voltage is steady, the thermal conditions are in steady state.

This technique measures thermal conductivity at a single point. To obtain an average value for the thermal conductivity of a nonhomogeneous material, statistically valid sampling techniques must be used.

MEASUREMENT PROCEDURES

The thermistors used in the measurements described in this report were Fenwal GB32P101-T. Earlier tests used similar glass bead thermistors manufactured by Victory Engineering Corporation. Any glass bead thermistor is suitable, including double bead thermistors that match a known curve. When selecting a thermistor, some care must be taken to ensure the glass diameter is large compared to the grain size of the material being tested (i.e., that there is good thermal coupling between the thermistor and the material). To make it easier to insert the thermistor into a test material, a piece of dual-wall heat-shrink tubing can be shrunk onto the thermistor's glass bead extension to form a convenient probe (Fig. 2).

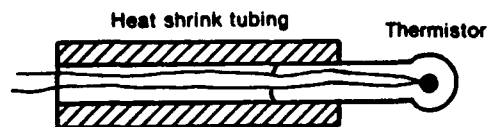

Figure 2. Thermal conductivity probe.

A number of different circuit configurations are possible (Fig. 3). No matter which circuit is used, they all do the same thing; namely, they provide a small current to read the lower ("cold") temperature and then a larger current to heat the thermistor, while at the same time reading the higher ("hot") temperature. Typical lower temperature currents are 30 to 70 μ A, and typical higher temperature currents are 2 to 5 mA.

For the lower temperature reading it is necessary to know the current in the thermistor and the voltage across the thermistor so that the thermistor resistance can be determined. The lower temperature

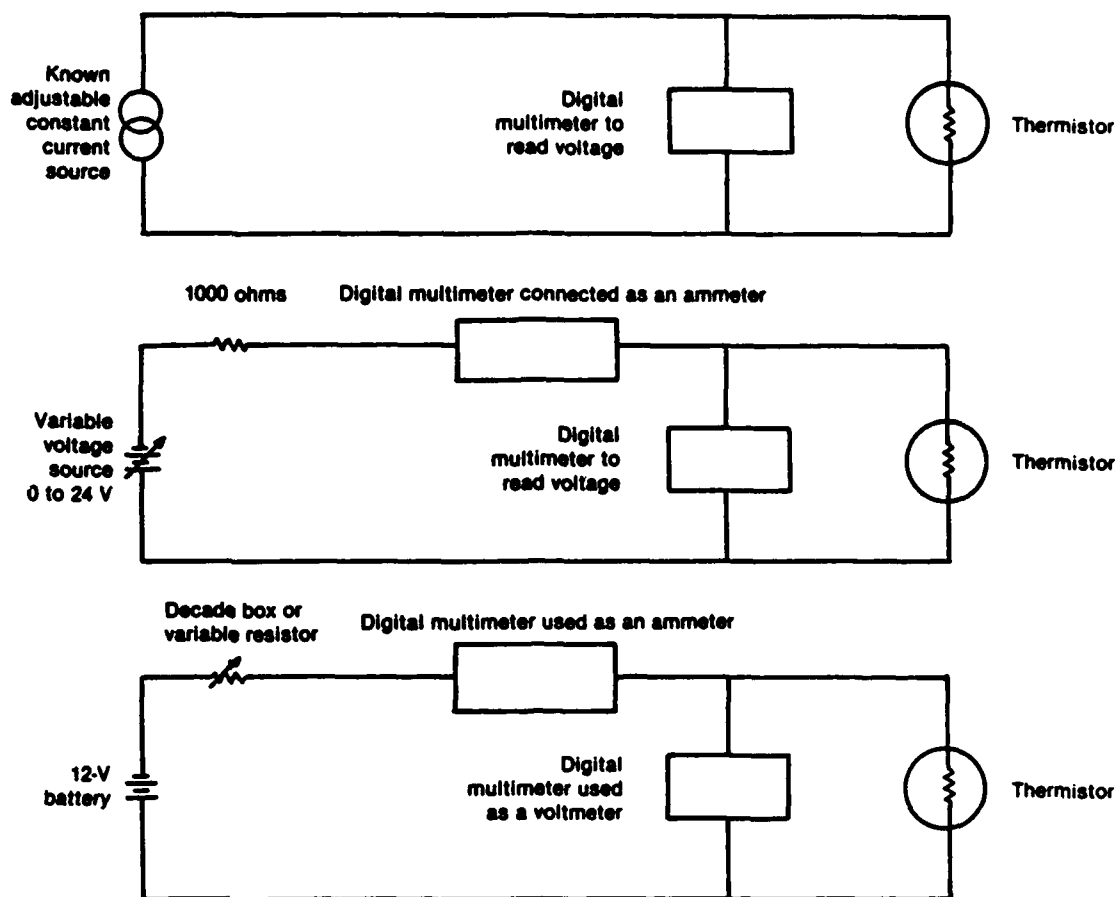

Figure 3. Three possible circuit configurations.

is then found using standard thermistor- temperature measuring techniques (discussed briefly in the following section).

At the higher temperature, the energy being applied is calculated, as well as the temperature itself. Since the current in the thermistor and the voltage across it are known, $Q = 0.2389 I \cdot V$ is the energy flow in calories per second.

Typical measurement

The step-by-step procedure for a typical measurement is as follows:

1. Insert the thermistor in the test material and connect the electrical circuit.
2. Apply a small, lower-temperature current, for instance, $40 \mu\text{A}$.
3. Observe the voltage across the thermistor; when it becomes steady (a change of only 1 or 2 mV/min), record the voltage and the current. These two values are then used to calculate the thermistor's resistance and, hence, the lower temperature.
4. Apply a heater current, for example, 3 mA. Note the time when this current is applied.
5. Observe the voltage across the thermistor; when it becomes steady, record the current and voltage. Typically, at room temperature, it takes from 5 to 10 minutes for the temperature to stabilize. The time interval over which the heater current was applied should also be recorded.
6. Calculate the higher temperature and the thermal energy Q being dissipated in the sample.
7. Reapply the lower-temperature current and wait the same time interval over which the heater current was applied.* Record the current and voltage and calculate the lower temperature again.

*The assumption here is that the sample is changing temperature slowly and that the "hot" reading should be taken equidistant in time between the two "cold" readings to account for this temperature change.

8. Average the two lower temperatures.

9. Calculate the thermal conductivity of the test material using:

$$K_m = \frac{BQ}{(T_{\text{hot}} - T_{\text{cold}}) - AQ}$$

The calibration process is exactly the same as above except that K_m is known for the two calibration materials and the values of A and B are calculated using the two equations-two unknowns method. Typical calibration materials are as follows:

Water:

$$K_m = 1.43 \times 10^{-3} \text{ cal/cm-s-}^\circ\text{C}$$

Silicone oil:

$$K_m = 0.30 \times 10^{-3} \text{ cal/cm-s-}^\circ\text{C}$$

Example: Test material: dry silt

As an example, we will consider the thermal conductivity of a sample of dry Fairbanks silt (from Fairbanks, Alaska), which produces the following three readings:

Time	Current (μA)	Volts
0845	30	0.06982
0850	3000	5.254
0855	30	0.06966

First lower temperature:

$$R = \frac{0.06982}{30 \times 10^{-6}} = 2327.3 \text{ ohms}$$

First lower temperature = 21.19 °C. (This was obtained from the resistance-temperature data supplied by the thermistor manufacturer. See also the following section.)

Higher temperature:

$$R = \frac{5.254}{3 \times 10^{-3}} = 1751.3 \text{ ohms}$$

Higher temperature = 28.51 °C.

Second lower temperature:

$$R = \frac{0.06966}{3 \times 10^{-3}} = 2322.0 \text{ ohms}$$

Second lower temperature = 21.25 °C.

Average lower temperature:

$$\frac{21.19 + 21.25}{2} = 21.22 \text{ }^\circ\text{C}$$

$$Q = 0.2389 \times 3 \times 10^{-3} \times 5.254 = 3.7655 \text{ mcal/s.}$$

From eq 7 with $A = 792.3573$; $B = 0.36003$:

$$K_m = \frac{0.36003 \times 3.7655 \times 10^{-3}}{(28.52 - 21.22) - 792.3573 \times 3.7655 \times 10^{-3}} = 0.315 \times 10^{-3} \text{ cal/cm-s-}^\circ\text{C}$$

or

$$K_m = \frac{0.315 \times 10^{-3}}{3.44 \times 10^{-4}} = 0.916 \text{ BTU/ft}^2/\text{in./hr/}^\circ\text{F}.$$

If this had been a calibration process, the procedure would have been exactly the same except the value of K_m would have been known (for instance, using distilled water). By using two "standard" materials whose K_m values are known, the values for A and B for a particular thermistor could then be calculated.

Thermistor thermometry

There are several methods of converting a thermistor's resistance to temperature. The method used for this report was to purchase thermistors calibrated at three temperature points: -38° , 0.01° and $+40^\circ\text{C}$. These three known points were then used to generate resistance-temperature tables in 0.1°C increments from -40°C to $+40^\circ\text{C}$ using the Steinhart equation:

$$\frac{1}{T_{\text{abs}}} = C_1 + C_2 \ln R + C_3 (\ln R)^3$$

where T_{abs} is the absolute temperature in kelvins, R is the resistance (in ohms) of the thermistor, and C_1 , C_2 and C_3 are constants that may be determined by using the three calibration points supplied with each thermistor. For the resistance temperature tables, the absolute temperature is usually converted to $^\circ\text{C}$ by subtracting 273.15.

Once the values for C_1 , C_2 and C_3 have been found, it is often convenient to program a small hand-held calculator to solve the Steinhart equation so that resistance values can be converted to temperature without bothering to look them up in a table.

Typical results

To demonstrate the use of this technique, two measurement programs were conducted, one on Fairbanks silt and one on typical building insulation. Typical data for these two initial test programs are shown below. A third set of data taken on wastewater sludges is also included.

Fairbanks silt

The calibrations for the tests on Fairbanks silt are illustrated in Table 1. All tests were run with a cold-temperature current of $30 \mu\text{A}$ and a hot-temperature current of 3 mA . The calibration constants for the thermistor were obtained by calculating an A and B for each possible combination of raw calibration data and then averaging these values:

A	B
785.2716	0.38443
785.4557	0.38417
785.9818	0.38422
786.1658	0.38395

$$\bar{A} = 785.7187 \quad \bar{B} = 0.38419$$

$$K_m = \frac{0.38419}{[T(\text{hot}) - T(\text{cold})] - 785.7187 Q}$$

Table 1. Calibration data for one of the three thermistors.

Standard	Q ($\times 10^{-3}$)	T(hot) ($^\circ\text{C}$)	T(cold) ($^\circ\text{C}$)
water	4.2880	26.82	22.30
water	4.2952	26.78	22.25
silicone oil	3.6967	30.72	23.08
silicone oil	3.6931	30.75	23.12

For water:

$$K_m = 1.43 \times 10^{-3} \text{ cal/cm-s-}^\circ\text{C at } 23^\circ\text{C}.$$

For silicone:

$$K_m = 0.3 \times 10^{-3} \text{ cal/cm-s-}^\circ\text{C at } 23^\circ\text{C}.$$

Test data

Measurements were taken at three soil moisture contents: 3%, 17% and 26%. Four measurements were taken for each soil moisture content. The results are illustrated in Table 2. Each data set was examined statistically to ensure that every specific measurement should be included in the results as a valid number. The technique used was the "outlier detection" method described by Abernathy and Thompson (1973).

Table 2. Results of the tests on Fairbanks silt.

$Q \times 10^{-3}$	T(hot)	T(cold)	$K_m \times 10^{-3}$
<i>3% moisture content</i>			
3.7598	30.28	22.87	0.325
3.7734	30.18	22.95	0.340
3.7670	30.23	23.09	0.346
3.7670	30.23	23.15	0.351
	Average		0.340
	Standard deviation		0.011
<i>17% moisture content</i>			
4.3862	26.23	21.63	1.448
3.3812	26.27	21.65	1.430
4.3697	26.33	21.73	1.431
4.3661	26.36	21.73	1.404
	Average		1.428
	Standard deviation		0.018
<i>27% moisture content</i>			
4.4184	26.05	21.70	1.929
4.4012	26.15	21.86	2.037
4.3991	26.16	21.86	2.002
4.3798	26.27	21.98	1.964
	Average		1.428
	Standard deviation		0.047

Table 3. Results of the tests on 2-in. blue foam insulation.

Depth (in.)	K_m (BTU-in./hr-ft ² -°F)	
<i>Sample 4-3</i>		
1/4	0.317	$K_{hot\ box} = 0.622$
1/2	0.320	
3/4	0.551	$K_{avg} = 0.610$ $s = 0.221$
1	0.746	
1 1/4	0.730	Water by volume = 20.9% Water by weight = 752%
1 1/2	0.885	
1 3/4	0.709	
<i>Sample 4-4</i>		
1/4	0.329	$K_{avg} = 0.537$ $s = 0.255$
1/2	0.841	
3/4	0.660	$K_{hot\ box} = 0.591$ $K_{hot\ box} = 0.541$
1	0.860	
1 1/4	0.516	Water by volume = 16.7% Water by weight = 621%
1 1/2	0.277	
1 3/4	0.276	

These results (Fig. 4) are in agreement with those of other researchers who have measured the thermal conductivity of Fairbanks silts at various soil moisture contents (Farouki 1981).

Insulation material

These tests were conducted by the Mechanical Engineering Department of the University of Alaska, not by the authors, so only the results are reported, as received (Table 3). These tests measured the thermal conductivity at 1/4-in. intervals through the 2-in. test batts of insulation, and these values were averaged

for a total figure for the batt. At the same time a total value for the batt was obtained using the guarded hot box technique. As can be seen, the hot box reading and the average value using this thermistor method agree quite closely. The reason the thermistor readings increase as they proceed through the sample is that moisture was purposely introduced on one side of the sample for several hours prior to these measurements in order to determine 1) how much moisture was absorbed by the insulation batt, 2) to what depth the moisture had penetrated, and 3) how much the thermal insulation of the batt had deteriorated as a result of the moisture absorption. For sample 4-4 the original hot box measurement of 0.591 was considered suspect by the technician who was running the tests. Therefore, a second hot box measurement was made, resulting in the 0.541 BTU in./hr-ft²-°F measurement. (It is interesting to note that the technician decided that the thermistor measurements were more likely to be correct than the initial hot box measurement.)

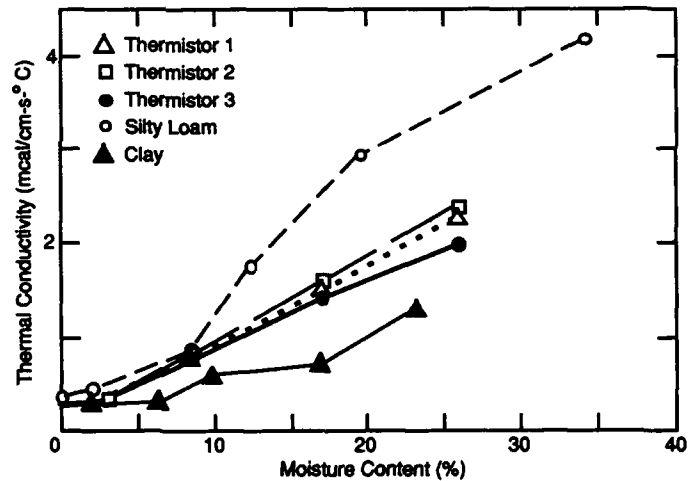

Figure 4. Thermal conductivity tests, Fairbanks silt (data for silty loam and clay are from Farouki 1981).

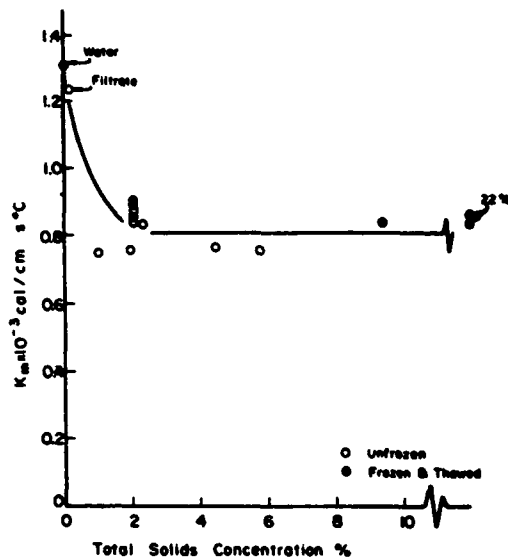

Figure 5. Thermal conductivity of Lebanon, N.H., water treatment sludge (from Vesilind and Martel 1989).

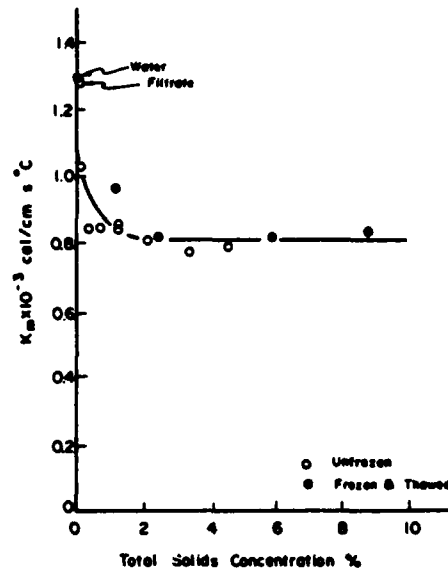

Figure 6. Thermal conductivity of West Lebanon, N.H., return activated sludge (from Vesilind and Martel 1989).

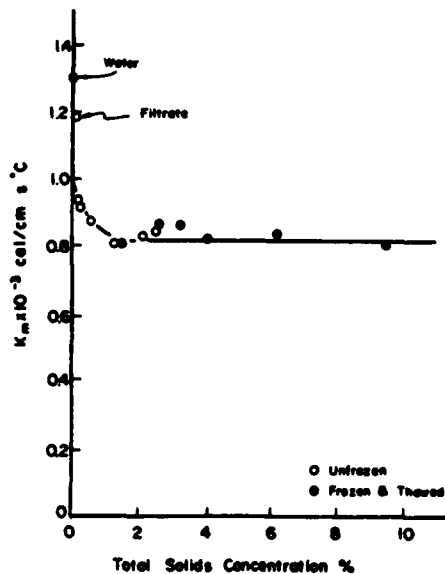

Figure 7. Thermal conductivity of Woodstock, Vt., return activated sludge (from Vesilind and Martel 1989).

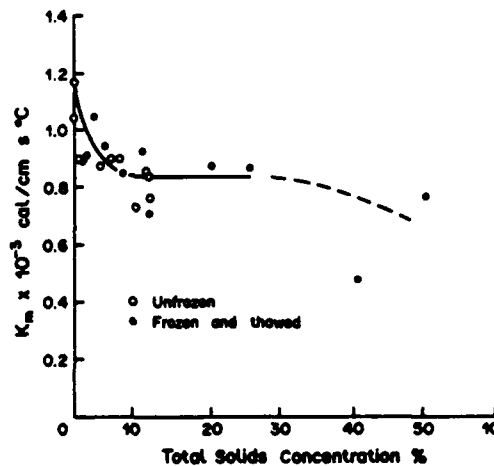

Figure 8. Thermal conductivity of Hanover, N.H., digested primary sludge (from Vesilind and Martel 1989).

Wastewater sludges

A third use of this thermal conductivity measurement technique is reported by Vesilind and Martel (1989) in their study of the thermal conductivity of sludges. For this particular application, the requirement was to determine the thermal conductivities of the liquids and slurries that are present in wastewater. These thermal conductivities were later used in predictive studies of freeze-thaw cycles of open lagoons in wastewater treatment plants. The results of these studies were reported for six different sludges (Fig. 5-10). As can be seen, a value of 0.8 mcal/cm-s-°C was found to be a good representative thermal conductivity for the sludges once the total solids concentration exceeded approximately 2%. In addition, the authors reported that this measurement technique produced repeatable data that were in general agreement with those of other researchers.

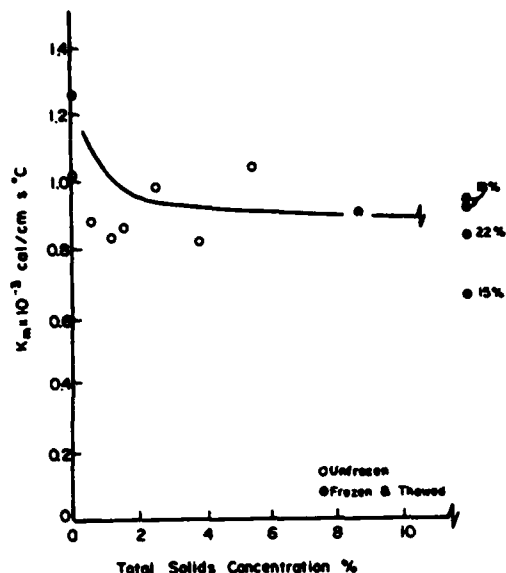

Figure 9. Thermal conductivity of Watervliet Arsenal (Watervliet, N.Y.) chrome sludge (from Vesilind and Martel 1989).

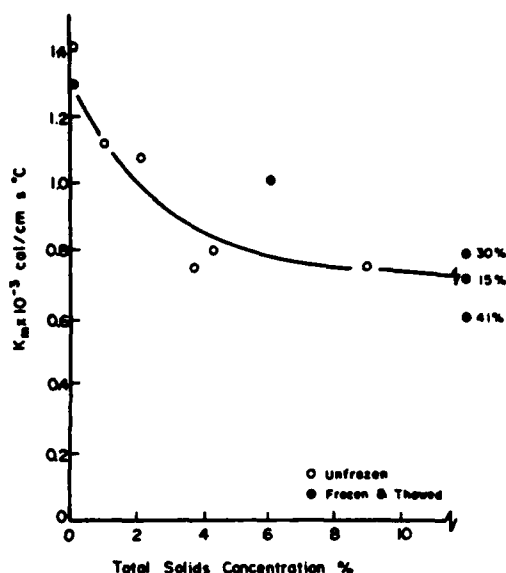

Figure 10. Thermal conductivity of Watervliet Arsenal oily sludge (from Vesilind and Martel 1989).

DISCUSSION OF RESULTS

The results reported here demonstrate the use of a technique that meets the requirements as stated in the *Introduction*. Two initial measurement programs were reported, one where relatively high thermal conductivities were measured (soil) and one where low conductivities were measured (insulation). A later series of tests involving wastewater sludges is also reported. In each case the results were compared to typical values obtained by other researchers using different measurement techniques. The results are in general agreement in all cases; however, the emphasis here is to describe the measurement technique. The accuracy comparisons do not have a great deal of meaning serving only to show that the sampling techniques used produced data in general agreement with other measurement techniques. This point measurement technique does have some unique characteristics for certain applications, such as profiling insulations that have absorbed moisture, or monitoring building insulations to detect moisture penetration.

The calibration materials used for all the measurements in this report were distilled water and silicone oil. The thermal conductivity for water at 25°C was obtained from a physics handbook. The silicone oil's conductivity was obtained from the manufacturer's specification sheets. The manufacturer warns that the data given are average values. However, a review of thermal conductivity tables shows that nearly all machine oils have a thermal conductivity of approximately 0.3×10^{-3} cal/cm-s-°C.

The use of water and silicone oil as calibrating standards will certainly have some small error due to convective cooling of the thermistor. This error is discussed in some detail in the thermal conductivity literature. Generally, the errors are dismissed as "acceptable" (less than 10% error) if the temperature difference between the sensor and the test material is small, (i.e., 10°C or less). On the other hand, a temperature of 5°C or more is necessary to make an accurate measurement. To stay within these temperature boundaries, it is necessary to choose the heater current with a little discretion. In general, low-conductivity materials will require only 2 or 3 mA while high conductivity materials will need 4 or 5 mA to achieve an acceptable temperature difference.

This measurement technique will ultimately result in the destruction of the thermistors since they are not designed to be heating devices. However, if care is taken to never exceed 40°C when heating the thermistor, a minimum of 40 tests can be expected. With a sample size of five thermistors available,

the average tests per thermistor were 70, and two were used for over 100 tests before failing. A good rule-of-thumb test to see if a thermistor is still giving correct temperatures is to place the thermistor in a constant-temperature environment (such as an ice bath) and take a forward and reversed reading. If the difference between the forward and reverse reading is more than 4 or 5 ohms, the thermistor is likely unstable and should be discarded.

CONCLUSIONS AND RECOMMENDATIONS

This method can be used to determine thermal conductivities that are reasonably close to, or below, the values for the calibration standards. However, for bulk materials it is imperative that statistically valid sampling techniques be used.

The test results in this report do not guarantee accurate measurements much above the thermal conductivity of water (1.43×10^{-3} cal/s-cm-°C). Although no tests were conducted, there is a high probability that the useful measurement range could be extended to higher conductivity materials by using higher-conductivity standards. Heat conductive compounds could probably be used as higher conductivity standards, although there might be some problems in accurately determining their thermal conductivity.

Obviously this technique will no longer be applicable once the thermal conductivity of the material starts to exceed the thermal conductivity of the glass on the thermistor (since the glass then becomes the material that is limiting heat flow).

LITERATURE CITED

- Abernathy, R.B. and J.W. Thompson** (1973) Uncertainty in gas turbine measurements. Air Force Handbook AEDC-TR-73-5, Engine Test Facility, Arnold Engineering Development Center, Air Force Systems Command.
- Dougherty, B.P.** (1987a) An automated probe for thermal conductivity measurements. Master's Thesis, Department of Mechanical Engineering, Virginia Polytechnic Institute and State University (unpublished).
- Dougherty, B.P.** (1987b) Thermophysical property measurement in building insulation materials using a spherically-shaped, self-heated probe. *Thermal Conductivity*, **20**: 47-59.
- Farouki, O.T.** (1981) Thermal properties of soils. USA Cold Regions Research and Engineering Laboratory, CRREL Monograph 81-1.
- Nieto de Castro, C.A., B. Taxis, H.M. Roder and W.A. Wakeham** (1988) Thermal diffusivity measurement by the transient hot-wire technique: A reappraisal. *International Journal of Thermophysics*, **9**(3): 293-316.
- Kreith, F.** (1961) *Principles of Heat Transfer*. Scranton: International Textbook Company.
- Vesilind, P.A. and C.J. Martel** (1989) Thermal conductivity of sludges. *Water Resources*, **23**(2): 241-245.

REPORT DOCUMENTATION PAGE

Form Approved
OMB No. 0704-0188

Public reporting burden for this collection of information is estimated to average 1 hour per response, including the time for reviewing instructions, searching existing data sources, gathering and maintaining the data needed, and completing and reviewing the collection of information. Send comments regarding this burden estimate or any other aspect of this collection of information, including suggestion for reducing this burden, to Washington Headquarters Services, Directorate for Information Operations and Reports, 1215 Jefferson Davis Highway, Suite 1204, Arlington, VA 22202-4302, and to the Office of Management and Budget, Paperwork Reduction Project (0704-0188), Washington, DC 20503.

1. AGENCY USE ONLY (Leave blank)		2. REPORT DATE June 1990	3. REPORT TYPE AND DATES COVERED		
4. TITLE AND SUBTITLE Thermistor-Based Thermal Conductivity Measurement System			5. FUNDING NUMBERS		
6. AUTHORS Ronald T. Atkins and Edmund A. Wright			8. PERFORMING ORGANIZATION REPORT NUMBER Special Report 90-24		
7. PERFORMING ORGANIZATION NAME(S) AND ADDRESS(ES) U.S. Army Cold Regions Research and Engineering Laboratory 72 Lyme Road Hanover, New Hampshire 03755-1290			10. SPONSORING/MONITORING AGENCY REPORT NUMBER		
9. SPONSORING/MONITORING AGENCY NAME(S) AND ADDRESS(ES) Alaska Department of Transportation and Public Facilities Fairbanks, Alaska 99701			11. SUPPLEMENTARY NOTES		
12a. DISTRIBUTION/AVAILABILITY STATEMENT Approved for public release; distribution is unlimited. Available from NTIS, Springfield, Virginia 22161			12b. DISTRIBUTION CODE		
13. ABSTRACT (Maximum 200 words) This report describes a patented method for using commercially available thermistors to make in-situ thermal conductivity measurements with commonly available electronic equipment such as digital voltmeters. The emphasis is on the use of a single thermistor to measure the thermal conductivity of soils. Calibration techniques are explained and examples provided. Limits on this technique are discussed, including measurement range, material grain size, the amount of material needed for a valid measurement, and temperature stability. Specific examples of the use of this technique are provided for thermal conductivity measurements of soils, building materials, and the sludges in a sewage treatment plant. Data analysis is provided, including a statistical approach to finding the thermal conductivity in large volumes of material.					
14. SUBJECT TERMS Building materials In-situ measurement			Soils Thermal conductivity	Thermistors	15. NUMBER OF PAGES 16
17. SECURITY CLASSIFICATION OF REPORT UNCLASSIFIED			18. SECURITY CLASSIFICATION OF THIS PAGE UNCLASSIFIED	19. SECURITY CLASSIFICATION OF ABSTRACT UNCLASSIFIED	16. PRICE CODE
17. SECURITY CLASSIFICATION OF REPORT UNCLASSIFIED			18. SECURITY CLASSIFICATION OF THIS PAGE UNCLASSIFIED	19. SECURITY CLASSIFICATION OF ABSTRACT UNCLASSIFIED	20. LIMITATION OF ABSTRACT UL

NSN 7540-01-280-5500

☆ U. S. GOVERNMENT PRINTING OFFICE: 1990--700-057--22021

Standard Form 298 (Rev. 2-89)
Prescribed by ANSI Std. Z39-18
298-102