

AD-A215 042

REPORT DOCUMENTATION PAGE

Form Approved
OMB No. 0704-0188

Public reporting burden for this collection of information is estimated to average 1 hour per response, including the time for reviewing instructions, searching existing data sources, gathering and maintaining the data needed, and completing and reviewing the collection of information. Send comments regarding this burden estimate or any other aspect of the collection of information, including suggestions for reducing the burden, to Washington Headquarters Services, Directorate for Information Operations and Reports, 1215 Jefferson Ave Highway, Suite 1204, Arlington, VA 22202-4302, and to the Office of Management and Budget, Paperwork Reduction Project (0704-0188), Washington, DC 20503.

AGENCY USE ONLY (Leave blank)

2. REPORT DATE
June 1983

3. REPORT TYPE AND DATES COVERED
Final (1 May 79 - 31 Dec 82)

TITLE AND SUBTITLE
SOLID PROPELLANT COMBUSTION PHENOMENA

5. FUNDING NUMBERS

61102F
2308/A1

AUTHOR(S)

Merrill W. Beckstead

PERFORMING ORGANIZATION NAME(S) AND ADDRESS(ES)

Brigham Young University
Department of Chemical Engineering
Provo, UT 84602

6. PERFORMING ORGANIZATION REPORT NUMBER

AFOSR-TR-89-1363

9. SPONSORING / MONITORING AGENCY NAME(S) AND ADDRESS(ES)

AFOSR
BLDG 410
BAFB DC 20332-6448

10. SPONSORING / MONITORING AGENCY REPORT NUMBER

AFOSR-79-0100

11. SUPPLEMENTARY NOTES

12a. DISTRIBUTION / AVAILABILITY STATEMENT

DTIC release;
distribution unlimited.

12b. DISTRIBUTION CODE

13. ABSTRACT (Maximum 200 words)

DTIC
ELECTE
DEC 06 1989
S D D

14. SUBJECT TERMS

15. NUMBER OF PAGES
16

16. PRICE CODE

17. SECURITY CLASSIFICATION OF REPORT

unclassified

18. SECURITY CLASSIFICATION OF THIS PAGE

unclassified

19. SECURITY CLASSIFICATION OF ABSTRACT

20. LIMITATION OF ABSTRACT

ACKNOWLEDGEMENTS

This investigation was supported by the Air Force Office of Scientific Research under the AFOSR grant No. AFOSR-79-0100 covering the time period from May 1979 to December 1982. The technical program manager is Dr. Leonard H. Caveny.

This report was prepared by Dr. Merrill W. Beckstead, the principal investigator on the program. Personnel involved in the project on the various tasks over the three year period have included:

Task 1

Diffusion Flame Analysis	Brad Eldridge (M.S. candidate) Scott White (undergraduate) Earl Pack (undergraduate)
--------------------------	--

Task 2

Double Base Flame Kinetics	Richard Raun (Ph.D. candidate)
----------------------------	--------------------------------

Task 3

Particle Damping of Burning Particles	B. Scott Brewster (faculty) Lynn Gordon (M.S. candidate) Ray Richards (undergraduate) George Witmer (undergraduate)
--	--

PUBLICATIONS AND PRESENTATIONS

Eldredge, H.B., Beckstead, M.W., and White, S.C., "Diffusion Flame Structure," presented at 18th JANNAF Combustion Meeting Pasadena, CA.

Beckstead, M.W., Richards, R.S., and Brewster, B.S., "Distributed Combustion Effects on Particle Damping," presented at AIAA 20th Aerospace Sciences Meeting in Orlando, FL as AIAA preprint 82-0357 (This paper has been accepted for publication in the AIAA Journal and is in the final stages of review).

Eldredge, H.B., Beckstead, M.W., and White, S.C., "Solid Propellant Diffusion Flame Structure," presented at 19th JANNAF Combustion Meeting, Greenbelt, MD.

Beckstead, M.W., Richards, R.S., and Brewster, B.S., "The Effect of Burning Particles on Acoustic Particle Damping," presented at the 19th JANNAF Combustion Meeting, Greenbelt, MD.

INTRODUCTION

This final scientific report has been prepared by Dr. M.W. Beckstead of Brigham Young University's Department of Chemical Engineering. It reviews the progress from May 1979 to December 1982 on a program to study various aspects of solid propellant combustion phenomena. The original program included three specific areas of study:

1. Diffusion flame analysis;
2. Kinetic mechanisms of double base propellants;
3. Interaction effects of distributed particle combustion in acoustic environments.

The diffusion flame is the controlling mechanism in the combustion of composite propellants. Therefore, a thorough understanding of diffusion flames is prerequisite to understanding solid propellant combustion, and was the objective of one task of the program. The second task of the program was motivated by the desire to better understand transient combustion such as occurs in ODI and combustion instability. Double base propellant combustion is dominated by the flame kinetics which appear to be more easily studied than those of composite propellants. The final task of the program was aimed at understanding the effect of stability additives on combustion instability.

During the final year of the contract, work on the first two tasks was discontinued and all work was concentrated on the third task. Interim reports covering the initial work have been published in December 1980 and February 1982. This report summarizes the work performed during the final phase of the contract covering the time from October 1981 through December 1982. *Keywords:*

Solid Rocket propellants; (17) ←

PROGRAM APPROACH AND OBJECTIVES

A. REASON FOR RESEARCH--HISTORY AND BACKGROUND

Acoustic suppressants are commonly added to low smoke and smokeless propellants to avoid the problem of combustion instability. However, the basis for selecting the type, size and concentration of suppressant particle for optimum performance is not well founded. These suppressants apparently work by one or more of three mechanisms:

- (1) energy loss due to viscous dissipation of drag forces,
- (2) modification of the propellant combustion response function, or
- (3) energy interchange due to distributed combustion.

Previous work by Diederichsen [1] gave credence to the idea of using a modified Rijke tube to study the effects of distributed combustion of particles on the acoustics in a rocket motor. His work went so far as to roughly and very qualitatively show that some particle additives seemed to be more effective acoustic damping agents than others. Our purpose was to extend Diederichsen's approach and construct a burner in order to get quantitative as well as qualitative acoustical data, and then use these data to interpret how acoustic suppressants work.

B. EXPERIMENTAL METHOD--BURNER AND ADVANTAGES

The principal objective of this work was to determine the effect that distributed combustion of acoustic suppressants has on combustion instability. The experimental basis for the technical approach is a modified Rijke tube, a gas burner with an attendant paddle to control (stop and start) oscillations (see Figure 1). This burner is probably more correctly called a 'gauze burner' rather than a Rijke tube burner, as explained by Diederichsen,

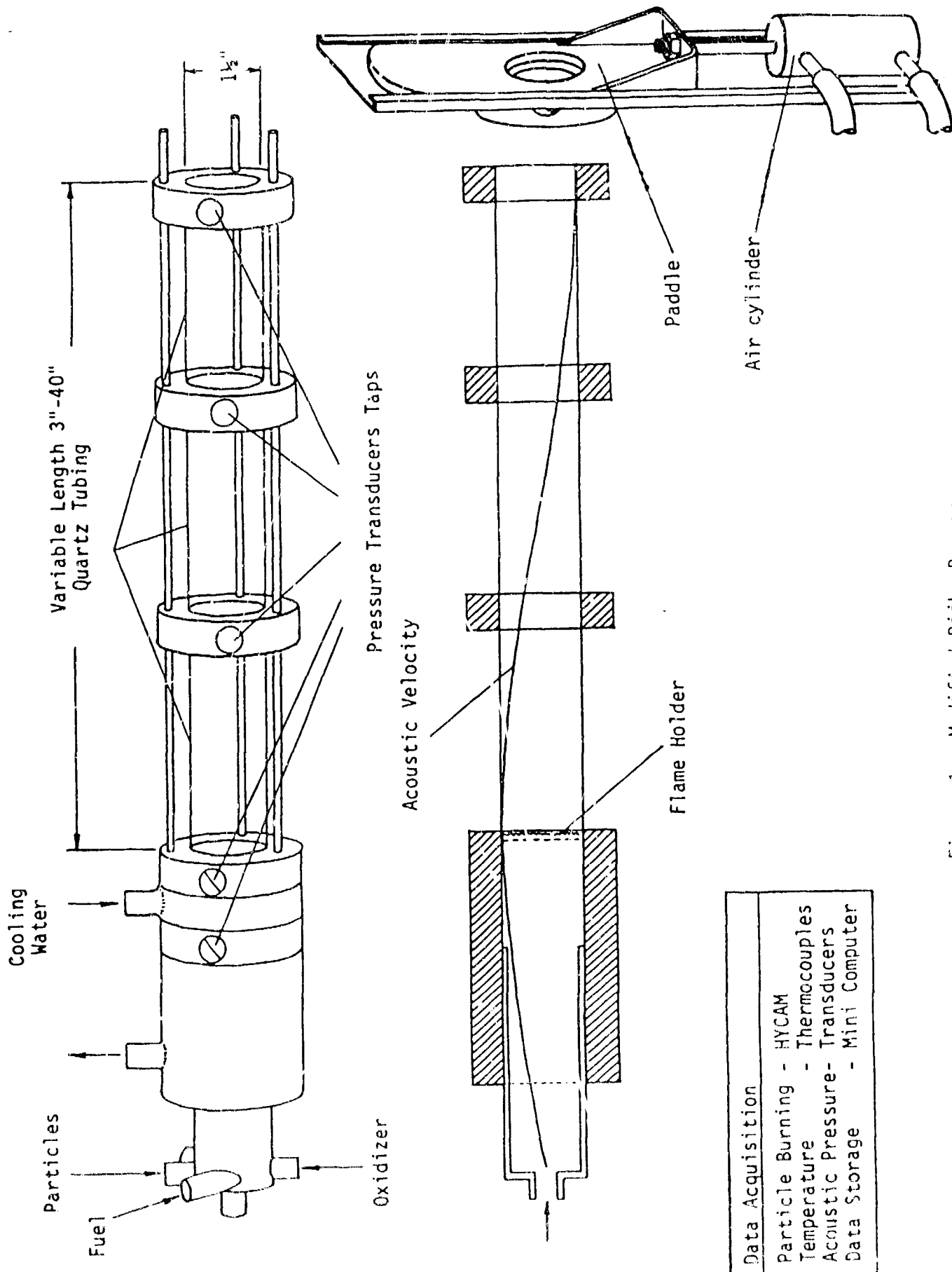

Data Acquisition	
Particle Burning	- HYCAM
Temperature	- Thermocouples
Acoustic Pressure	- Transducers
Data Storage	- Mini Computer

Figure 1. Modified Rijke Burner

since the oscillations are apparently not driven by a heat transfer mechanism from the gauze flameholder to the gases but by a variation of the normal burning rate and velocity coupled to an acoustic mode by the pressure oscillations. However, the acoustics of the system are what would be expected from a Rijke tube.

Our approach is to study three types of particles (very reactive, slightly reactive, and inert) to determine the effect of variable energy release on the acoustic wave and viscous damping effects. This variable energy release is probably a function of both the amount of energy released and the rate at which it is released (rate of reaction of the burning particle). These effects can be studied by comparing very reactive and slightly reactive particles, particularly particles which have very different heats and rates of reaction. The inert particles will allow us to identify the effect due to just viscous particle damping.

The following are some of the technical advantages of using this modified Rijke tube or gauze burner approach:

(1) An additive can be tested independent of a solid propellant burning surface, allowing a separation of suppressant mechanisms between the modification of the burning surface response and distributed combustion effects.

(2) The system can be tested with and without particles, thus readily evaluating the system effects.

(3) Various types of particles (reactive or inert) can be tested under identical conditions to better identify actual mechanistic action.

(4) To perform tests, solid propellants do not need to be mixed, cured, etc., thus reducing costs tremendously.

(5) Particle addition, frequency, O/F ratio, and temperature can be independently controlled.

Data collection involves the following:

- (1) pre-combustion particle size distributions
- (2) gas flow rates
- (3) particle flow rates
- (4) acoustic pressure amplitudes (at 2 or more locations)
- (5) particle combustion tracking (high speed movies)
- (6) post combustion particle collections and examination
- (7) selected wall temperatures

Data analysis will also involve the following:

- (1) acoustic growth rate measurements
- (2) acoustic mode shape reconstruction
- (3) particle combustion times
- (4) viscous particle damping calculations

C. THEORETICAL ANALYSIS

In order to analyze the experimental data and interpret and extrapolate the results, a theoretical analysis of the Rijke burner is necessary.

D. EXPECTED RESULTS AND FUTURE WORK

It is expected that several mechanisms will be shown to act together to dampen acoustic oscillations, with one mechanism perhaps dominating under certain conditions and another mechanism dominating at other times. Future work is to complete the experimental data gathering, analyze the data, complete the theoretical work, and then try to identify controlling mechanisms of acoustic solid particle interaction with the intent to apply this knowledge to actual rocket motors.

RESULTS

A. INTRODUCTION

The burner has been constructed, diagnostic equipment has been purchased and assembled, and checkout tests to characterize the burner limits have been mostly completed. Preliminary tests were run, and current work is examining this preliminary data and making test refinements and minor modifications to the system.

The major accomplishment has been to extend Diederichsen's approach and modify the burner so as to be able to get quantitative information from the burner that should not only enable us to quantify the acoustic effects of different propellant additives, but to also gain insight into the mechanisms by which reactive burning particles influence acoustic instability.

B. BURNER CONSTRUCTION

Figure 1 is a schematic of the burner configuration. It is a gas burner which will allow independent variations in the O/F ratio and the flame temperature. Particles are added in the gas inlet and are ignited by the flame. The flame holder is located at least one-quarter wavelength into the burner to allow standing wave oscillations to develop (i.e. a Rijke tube). High frequency pressure transducers are used to measure the acoustic pressure amplitude, which ranges from 0.005 to 0.050 psi, and a HYCAM camera is used to observe the extent of particle burning by observation through the quartz walls.

C. BURNER TESTING

This burner has been built, tested, modified, and thoroughly characterized both at steady conditions as well as at various oscillatory conditions. The frequency of the oscillations, varied by changing the

upstream and downstream burner lengths, ranges from 700 to 1200 Hz., and can easily be extended with slight modifications downward to 300 Hz or upward to 2000 Hz.

We spent some time and effort characterizing the burner and the following results are consistent with those of Diederichsen. A gauze flame, similar to a singing flame or a Rijke tube effect, can indeed be stabilized on a gauze flameholder at or near an acoustic velocity node. This nodal frequency of oscillations depend on both the upstream and downstream tube lengths, and there is a certain tube length below which oscillations cease.

We also found that the frequency can be controlled very closely with the tube lengths. The O/F ratio can be controlled with gas flowmeters, and the oscillation amplitude can be controlled to some extent by the nitrogen flow, which also controls the flame temperature.

D. PADDLE CONSTRUCTION

The major effort of the past year was to find a way to control (stop and start) the oscillations, since growth curves of oscillations give much more valuable information than does limiting amplitude data, which is all that has been previously measured. The method selected to do this and the major modification to Diederichsen's approach was to put a paddle on the top, open end of the burner (see Figure 1) to suddenly block off the burnt gas flow and turn an acoustic velocity anti-node into a velocity node. This effectively shuts down the oscillations, and opening the paddle again allows the oscillations to grow. The resultant growth curve allows the measurement of the linear damping coefficient which is a characteristic of the acoustic wave.

E. PADDLE TESTING

This paddle has been designed, constructed and tested, and has been shown to damp out oscillations, though there remains some residual noise (from six to twelve percent) of the maximum limiting amplitude. This noise, however, does not seem to extend into the linear part of the growth curve, and is usually a different frequency. Therefore, it may not be a serious problem. However, there is a significant problem concerning the speed the paddle moves. Due to the unexpected severity of the acoustic driving force ($\alpha \sim 500 \text{ sec}^{-1}$), the growth curve is well developed before the paddle can completely finish uncovering the tube. This means that at present our data are suspect of being influenced more by the paddle than by the acoustics of the particles and the system. Present efforts are attempting to further modify the paddle to increase its speed so that it will completely uncover the tube in less than one acoustic oscillation cycle. Also, operating conditions are being varied to find conditions that will produce lower growth rates.

F. PRELIMINARY RESULTS

Preliminary results with small amounts of aluminum particles (roughly 1-2%) indicate that it should be possible to get the data desired. The addition of particles does significantly change the linear growth rate as expected. The limiting amplitude of the oscillations is also changed. In one case (see Figure 2) a reduced growth rate showed that the particles were damping the oscillations, while the limiting amplitude increased indicating that the particles could be driving rather than damping the oscillations. These mixed results are not really contradictory, in that α is a measure of the linear acoustic growth while the limiting amplitude is more dependent on a multitude of non-linear effects.

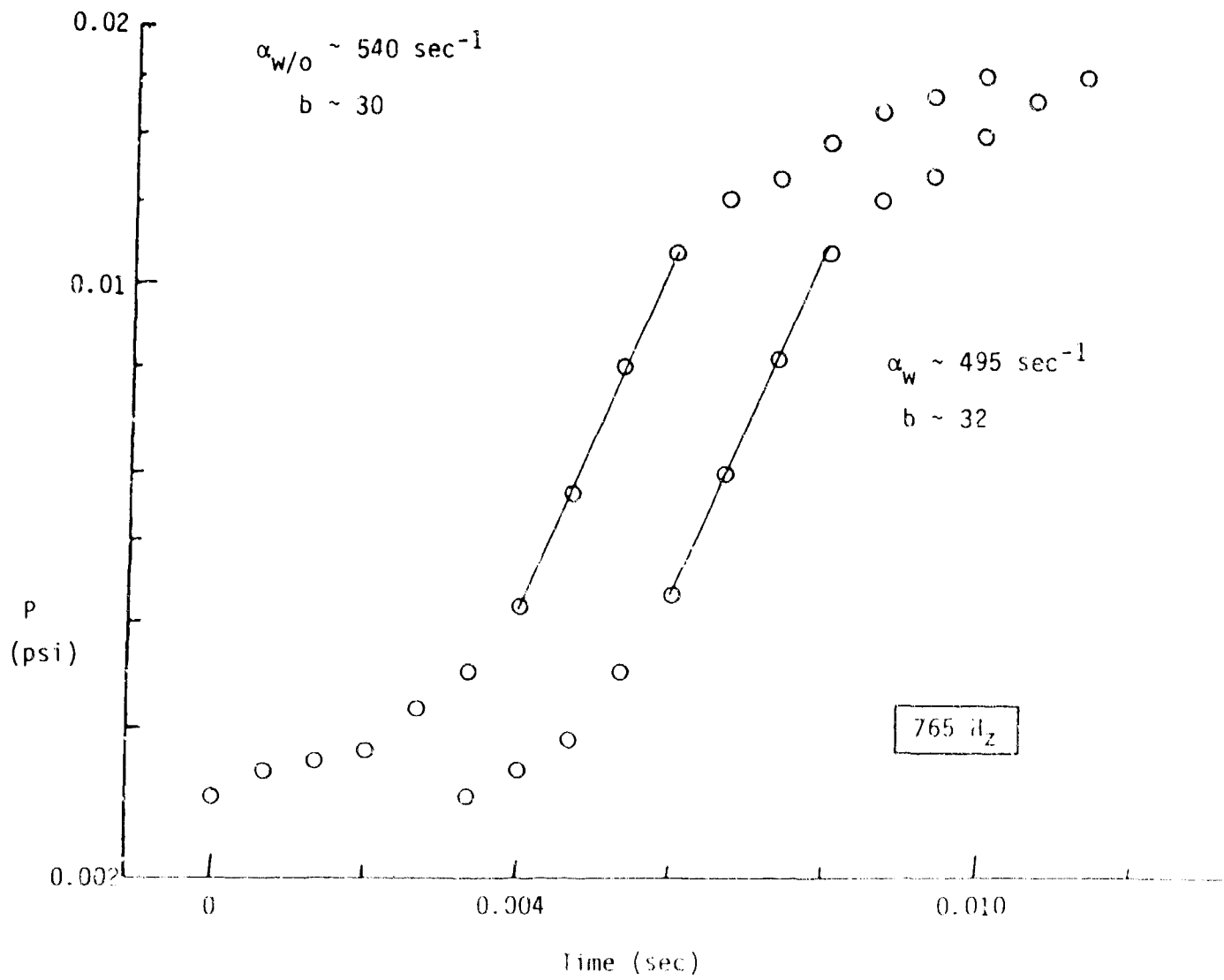

Figure 2. Comparison of typical acoustic growth data from the modified Rijke burner. The upper curve is a gas only firing. The lower curve was at the identical conditions with 1-2% 20µm Al added.

As mentioned previously, the driving force is much stronger than originally expected, giving rise to an alpha much larger than is desirable. Current efforts based on these preliminary results will be to decrease the severity of system driving, increase the paddle speed, extend the burner's range of operation, and obtain the desired quantitative results.

G. THEORETICAL ANALYSIS

The theoretical analysis of the Rijke tube system is underway concurrent with the experimental work. The development of a mathematical model of the Rijke tube began with an extensive literature review. Modern workers that have analyzed the Rijke tube mathematically include Neuringer and Hudson (2), Carrier (3), Jones (4), and Mugridge (5). A completely general analysis of the Rijke tube with particulate flow will require solution of the conservation equations for a multiphase flow. However, as the above authors performed analyses of the Rijke tube without particle flow, the complete set of conservation equations was not solved by any of them. The mathematical analyses on the Rijke tube performed by Neuringer and Hudson (2) and Carrier (3) are typical of all of the analyses performed, and are very similar.

The main objective of the mathematical modeling efforts of the above mentioned authors was calculation of the characteristic frequencies of the Rijke tube and the growth constants associated with each frequency.

The following assumptions were made by most authors:

- 1) All properties (pressure, temperature, density, velocity, thermal conductivity, heat capacity, and ratio of specific heats) were taken as constant in each tube section, with a step change in properties occurring across the flame or gauze.

- 2) One dimensional flow was assumed.

- 3) The effects of friction at the tube wall were neglected.

4) Small amplitude oscillations were assumed, thus allowing linearization of the conservation equations.

5) The acoustic oscillations were assumed to be sinusoidal with respect to time.

6) The flame or heater gauze was taken as thin enough to be neglected, and in most cases was treated as a simple discontinuity between the cold and hot tube sections.

7) Most analyses neglected the effects of gravity and other body forces.

8) The flame speed was assumed to be negligible compared to the speed of sound.

The primary difference between the models was the manner in which the fluctuating heat transfer from the gauze or flame was represented. As the continuity conditions of the gauze or flame were derived from the mathematical equations chosen to describe the heat source, the values obtained for the characteristic frequencies and associated growth constants were effected by the flame representation.

As a result of the similarity between Carrier's approach and that of Neuringer and Hudson, the final eigenvalue equation obtained by Carrier was quite similar to that obtained by Neuringer and Hudson. However, there were some differences between the two analyses.

The most significant difference was that Carrier did not apply assumptions 2) and 3), but used two-dimensional cylindrical coordinates in his analysis. Thus, the linearized partial differential equations obtained were functions of the radial coordinate as well as the axial coordinate and time. The radial portion of the solution accounted for the effects of viscous dissipation at the tube walls. The effect of this was a small but significant

change in the values of the complex eigenvalues accounting for the additional damping of oscillations due to viscous drag at the tube walls.

Second, Carrier modeled the gauze as a series of parallel heated strips. Using approximate boundary layer equations, he obtained an equation for predicting the variable heat transfer rate from the heated strips to an oscillating fluid. His attempt to model the heat release rate from the gauze represented an improvement, though not a significant difference between the two analyses.

Finally, Carrier attempted to formulate the open end boundary conditions more accurately than Neuringer and Hudson by drawing upon acoustic theory. Of the three differences between the analyses, the third is probably the least significant.

Although no articles were found in which operation of the Rijke tube with particle-laden flow was discussed specifically, some authors have discussed the effect of particles on oscillating flows.

Dobbins and Temkin (6) and Culick (7) both analyzed mathematically the effects of particles carried in an oscillating stream of gas. Dobbins and Temkin obtained an expression giving both the attenuation of the wave and the dispersion (change in the speed of sound) due to the particles. Culick (7) formulated a generalized equation for calculating the growth constants and frequencies of longitudinal oscillations in a chamber of variable cross-section with particulate flow and mass addition from the perimeter. He also demonstrated the use of his general equations by investigating the dynamics of the Rijke tube.

Expanding upon his earlier work, Culick (8,9) examined the influence of residual combustion by the particles in a particle-laden flow on the frequency and attenuation. In these works, Culick accounted for the effects of

combustion due to transformation of the particles from one composition to another, but he did not account for the effect of the interaction between the actual flame surrounding the burning particle and the oscillating gas.

Smoot and Pratt (10) discussed the formulation of the conservation equations for multicomponent flow. Their specific application was the combustion of pulverized coal dust in air, but the equations formulated were designed to handle any reacting or non-reacting particle-laden flow. These general equations will be the starting point for the work to be undertaken. The analysis to be performed will include the damping of oscillations by particles of arbitrary size distribution in a Rijke tube having a varying temperature distribution in the hot gas section. This modeling effort will apply Culick's work to the equations of Smoot and Pratt. Integration of the resulting differential equations will be accomplished by combination of analytical and numerical integration.

The objective of the modeling effort is to predict the frequencies and growth constants of oscillations produced by a Rijke tube, both with and without particle-laden flow. An attempt will be made to account for the effects of the combustion of the particles.

Detailed modeling of the response of the flame to pressure fluctuations will be avoided, as this is beyond the scope of the present study.

REFERENCES

1. Diederichsen, J. 1963. "A Singing Flame as a Tool for Evaluation of Damping Agents for Solid Propellant Rocket Motors." Combustion and Flame. 7:29-37.
2. Neuringer, J.L. and Hudson, G.E. 1952. An investigation of sound vibrations in a tube containing a heat source. The Journal of the Acoustical Society of America. 24(6):667-74
3. Carrier, G.F. 1954. The mechanics of the Rijke tube. Quarterly of Applied Mathematics. 12(4):383-95.
4. Jones, H. 1977. The mechanics of vibrating flames in tubes. Proceedings of the Royal Society of London, Series A. 353:459-73.
5. Mugridge, B.D. 1980. Combustion driven oscillations. Journal of Sound and Vibration. 70(3):437-52.
6. Dobbins, R.A. and Temkin, S. 1967. Propagation of sound in a gas-particle mixture and acoustic combustion instability. American Institute of Aeronautics and Astronautics Journal. 5(12):2182-6.
7. Culick, F.E.C. 1970. Stability of longitudinal oscillations with pressure and velocity coupling in a solid propellant rocket. Combustion Science and Technology, 2:179-201.
8. Culick, F.E.C. "Influence of residual combustion." Memorandum to M.W. Beckstead, Hercules, Inc., Magna, Utah, 26 September 1974.
9. Culick, F.E.C. "Formulation of an example showing the possible influence of residual burning on particle damping in a t-burner." Memorandum to M.W. Beckstead, Hercules, Inc., Magna, Utah, 2 January 1975.
10. Smoot, L.D. and Pratt, D.T. 1979. Pulverized-coal combustion and gasification, pp. 15-24. New York: Plenum Press.