

UNCLASSIFIED

AD 273 458

*Reproduced
by the*

**ARMED SERVICES TECHNICAL INFORMATION AGENCY
ARLINGTON HALL STATION
ARLINGTON 12, VIRGINIA**



UNCLASSIFIED

NOTICE: When government or other drawings, specifications or other data are used for any purpose other than in connection with a definitely related government procurement operation, the U. S. Government thereby incurs no responsibility, nor any obligation whatsoever; and the fact that the Government may have formulated, furnished, or in any way supplied the said drawings, specifications, or other data is not to be regarded by implication or otherwise as in any manner licensing the holder or any other person or corporation, or conveying any rights or permission to manufacture, use or sell any patented invention that may in any way be related thereto.

CATALOGED BY ASTIA

NASA TN D-1122

AD NO.

273458

273 458

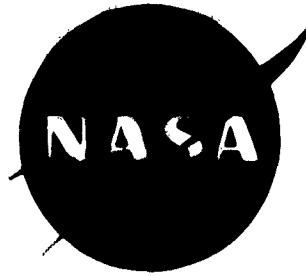

TECHNICAL NOTE

D-1122

TRACKING OF CYGNUS A AND CASSIOPEIA A BY THE NASA 108-MC MINITRACK SYSTEM

E. J. Habib, J. H. Berbert, and D. W. Harris

Goddard Space Flight Center
Greenbelt, Maryland



NATIONAL AERONAUTICS AND SPACE ADMINISTRATION
WASHINGTON
March 1962

TRACKING OF CYGNUS A AND CASSIOPEIA A BY THE NASA 108-MC MINITRACK SYSTEM

by

E. J. Habib, J. H. Berbert, and D. W. Harris

Goddard Space Flight Center

SUMMARY

Meridian transit passes of Cygnus A and Cassiopeia A are being recorded by the 108-Mc Minitrack system that was designed for precise satellite tracking. This paper covers the period from October 16, 1960 to December 31, 1960. The data were reduced to determine the flux densities and celestial positions of these two sources. The values obtained by this system are within the experimental error of those determined by other experimenters on slightly different frequencies.

CONTENTS

Summary	1
INTRODUCTION	1
EQUIPMENT	1
CALIBRATION	5
SIGNAL STRENGTH AND FLUX DENSITY	5
RECORDING A STAR PASS	6
REDUCING THE DATA	6
RADIO REFRACTION AND SCINTILLATION	12
CONCLUSION	12
ACKNOWLEDGMENTS	12
References	12
Bibliography	13

TRACKING OF CYGNUS A AND CASSIOPEIA A BY THE NASA 108-MC MINITRACK SYSTEM

by

E. J. Habib, J. H. Berbert, and D. W. Harris

Goddard Space Flight Center

INTRODUCTION

The Minitrack system, a radio interferometer system, was designed for the precise tracking of artificial earth satellites. Initially operating at a frequency of 108 Mc, it has been changed by the addition of a 136.5-Mc capability at most of the stations and the installation of only 136.5 Mc at others. (A list of the NASA Minitrack stations and their tracking frequencies is given in Table 1.) The data used in this report were received from the station in Fort Myers, Florida, the coordinates of which are $05^{\text{h}}27^{\text{m}}27.7^{\text{s}}$ west longitude and $26^{\circ}32'53.5''$ north latitude. The data are for the period from October 16, 1960 to December 31, 1960, on a frequency of 108 Mc only.

The radio sources tracked, Cygnus A and Cassiopeia A, are referred to as radio stars. In reality the Cygnus source is two distant galaxies in collision, emitting nearly as much energy in the radio spectrum as in the visual spectrum, and the Cassiopeia source is a newly discovered type of galactic nebulosity (Reference 1).

EQUIPMENT

The basic arrangement of the 108-Mc Minitrack system is shown in Figure 1. It consists of a cross with the two widely separated antennas in each direction 500 feet (54.902 wavelengths) apart. Each antenna consists of eight slot-type elements polarized in the north-south direction and supported about 39 inches above a ground screen to provide a broad-side array (Figure 2). The ground screen measures 60 feet in the east-west direction and 10 feet in the north-south direction. The two antennas at the ends of the north-south leg provide the north-south phase difference measurement, and the two at the ends of the east-west leg provide the east-west measurement. Because the north-south antenna 3-db beamwidth is 76 degrees, two sets of ambiguity resolution antennas are required in this

Table 1
Minitrack Stations and Their Frequencies

Station Site	108 Mc	136.5 Mc
Antofagasta, Chile	X	X
Blossom Point, Maryland	X	X
East Grand Forks, North Dakota		X
College, Alaska		X
Fort Myers, Florida	X	X
Johannesburg, South Africa	X	X
Lima, Peru	X	X
Quito, Ecuador	X	X
St. Johns, Newfoundland	X	X
Mojave, California		X
Santiago, Chile	X	X
Winkfield, England		X
Woomera, Australia	X	X

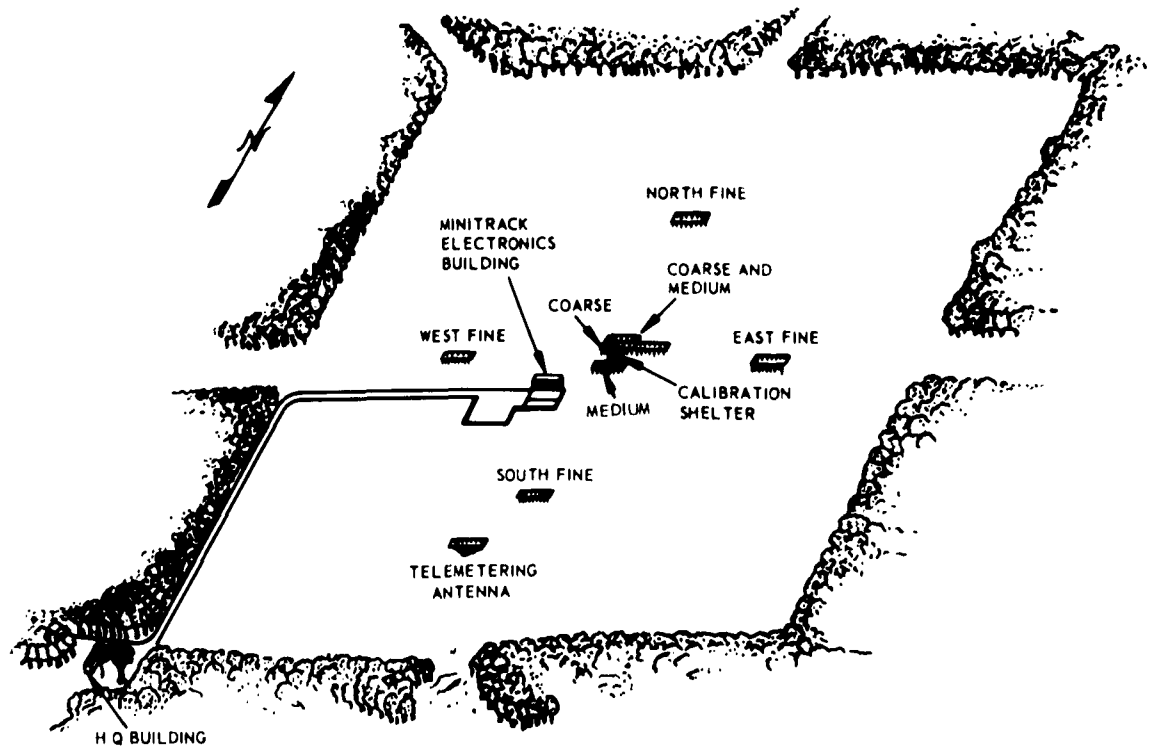

Figure 1 — Basic arrangement of a Minitrack ground station



Figure 2 — A108-Mc Minitrack antenna

direction. The east-west antenna 3-db beamwidth of 8 degrees requires only a single antenna pair for ambiguity resolution.

The signals received at the two antennas are fed to separate preamplifiers through nearly 300 feet of nitrogen-filled coaxial line, buried about 2 feet underground to aid in maintaining a nearly constant temperature. The noise figure of the preamplifiers is approximately 3 db. A block diagram of the receiver is shown in Figure 3. After pre-amplification, the signals are fed to the first mixers and converted into the two first IF signals, separated in frequency by 500 cps. This is accomplished by the use of the special local oscillator.

The heart of the Minitrack receiver system is a very stable special local oscillator (S.L.O.) which provides the conversion frequencies for the receivers and the reference signal for the phase meters. The initial section of the S.L.O. consists of two crystal oscillators, one at 11.7650 Mc and the other at 11.7655 Mc. These frequencies are translated by a common 131.0605-Mc crystal oscillator to 119.2955 and 119.2950 Mc respectively. The 11.7655 Mc oscillator also serves as the second local oscillator for the receiver system.

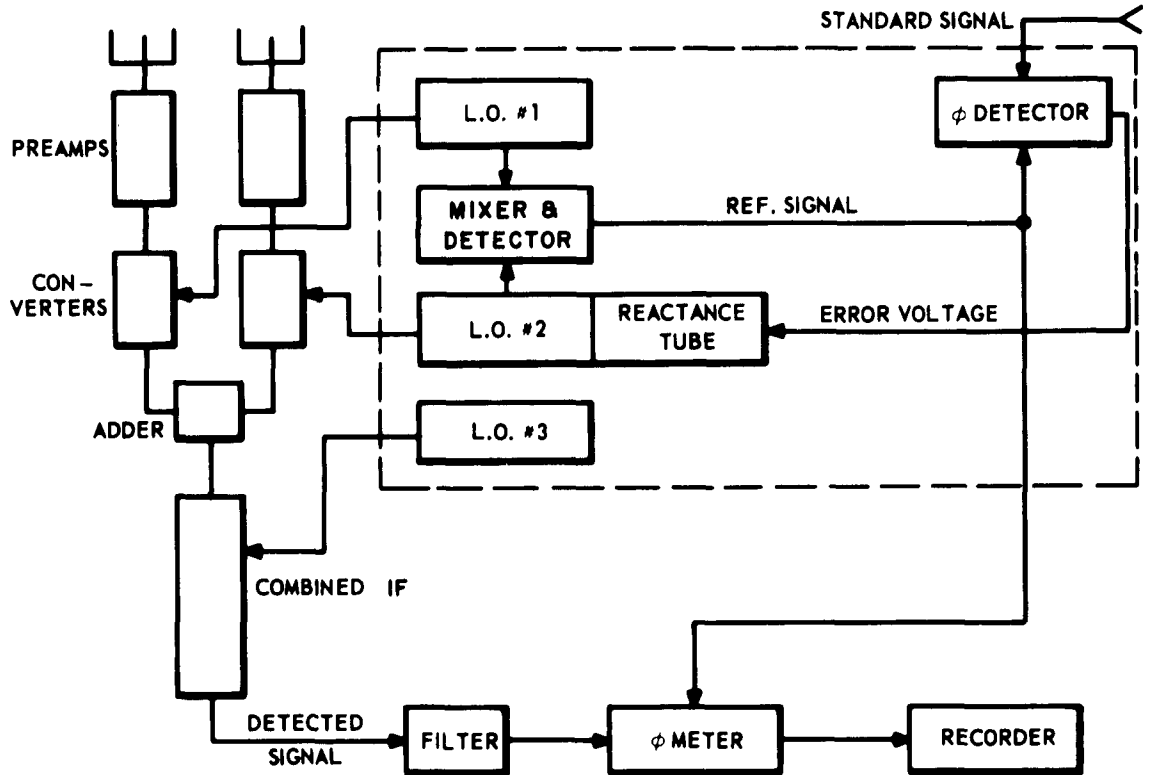

Figure 3 — Block diagram of the Minitrack receiver

The system is phase-locked by comparing the 119.2950- and 119.2955-Mc first local oscillator frequencies and detecting the 500-cps difference. This difference, which is called the 500-cps reference signal, is compared in a phase detector with a precise 500-cps signal from the time standard. The resulting error signal is used to control the 11.7650-Mc oscillator, and hence the 119.2955-Mc frequency, through a reactance tube.

The two IF signals of 11.2950 and 11.2955 Mc, obtained by mixing the first local oscillator frequencies and the incoming 108-Mc signal, are then combined in a simple adding circuit and amplified in a low-gain 10-Mc IF amplifier stage. The combined signals are converted to 469.5 and 470.0 kc in a second mixer, by using the second local oscillator frequency of 11.7650 Mc, and are here once again amplified — but this time by the system's primary amplifiers, where the bulk of the system gain occurs. The 10-kc bandwidth of this amplifier determines the predetection bandwidth of the receiver; and because the latter bandwidth is relatively broad compared to the 500-cps separation of the combined signals, very little differential phase error is introduced. The combined

output feeds a square-law detector, which reconstructs a 500-cps signal. This signal is passed through a 10-cps postdetection filter centered on 500 cps. The phase difference between this signal and the 500-cps reference signal from the S.L.O. unit is identical to the phase difference existing between the initial 108-Mc signals received at the two pre-amplifiers. This phase difference is converted to an analog voltage output, whose amplitude is directly proportional to the phase, and is then displayed on a Sanborn direct-writing paper recorder.

CALIBRATION

Each station is calibrated three times a year by optical means. A sidereally-driven camera with an f/5.0, 40-inch focal length lens, situated in the center of the antenna field, photographs a high-flying aircraft carrying a Minitrack transmitter and a flashing light against the star background on a clear night. The light flashes in a time-coded sequence, the time of each flash being known to within one millisecond. As the flashing light is photographed, the 108-Mc transmissions from the airplane are recorded by Minitrack as a function of time. The light positions are measured in relation to the adjacent stars, and a precise determination of the aircraft's position at the time of each flash can then be made. These positions are then correlated with the Minitrack recordings to provide the calibration constants for the station. The accuracy of the optical position determinations is estimated to be within 2 seconds of arc, or a factor of ten better than the design accuracy of the Minitrack system (about 20 seconds of arc for signals stronger than -120 dbm.) Frequent internal calibration of differential phase drift in the electronics helps to determine any drift in the system between airplane calibrations.

SIGNAL STRENGTH AND FLUX DENSITY

Although originally designed primarily for satellite tracking, the 108-Mc Minitrack system will successfully determine the position of any source with a signal strength equal to or stronger than -140 dbm at the receiver input. If we consider the antenna gain of 17.9 db and the predetection bandwidth of 10 kc we see that -140 dbm is equivalent to a flux density of $65 \times 10^{-24} \text{ w m}^{-2} (\text{cps})^{-1}$. The only celestial radio sources besides the sun with signal strengths exceeding this level at 108 Mc are Cygnus A and Cassiopeia A. Cygnus A has been recorded at -138 ± 2 dbm, equivalent to a flux density of $103 \times 10^{-24} \text{ w m}^{-2} (\text{cps})^{-1}$; Cassiopeia A has a signal strength of -137 ± 2 dbm, which corresponds to a flux density of $130 \times 10^{-24} \text{ w m}^{-2} (\text{cps})^{-1}$. These values compare favorably to those determined by other experiments (Table 2).

Table 2*
Flux Densities of Cygnus A and Cassiopeia A

Constellation	I.A.U. No.	Frequency (Mc)	Flux Density $\left(10^{-24} \frac{w}{m^2 \text{ cps}}\right)$
Cygnus A	19N4A	60	220
		81.5	135
		100	125
		101	130
		108†	200
		158	57
		3200	7.0
Cassiopeia A	23N5A	81.5	220
		158	93
		3200	15.0

*Reference 2

†Reference 3

RECORDING A STAR PASS

The radio star track is recorded on an eight-channel paper recorder which also has a special time recording channel. Two channels carry the fine phase measurements of the source position, three channels have the ambiguity resolving tracks, and the three remaining channels have the signal level of the source at the input to the receiver in dbm. Paper speed is usually set at 2.5 mm/sec; therefore, times can be read directly to the nearest second and estimated to the nearest tenth of a second. A recording for a Cassiopeia A pass is shown in Figure 4.

REDUCING THE DATA

The Fort Myers, Florida, station computes local transit time of both radio stars, basing its determinations upon the positions of the stars given in the January 1955 issue of the *Astrophysical Journal* (Reference 2).

The Minitrack recorders are turned on approximately five minutes before the estimated transit time and turned off five minutes after. If any other radio source, such as the sun or an artificial earth satellite, is within the beam pattern, no record is made.

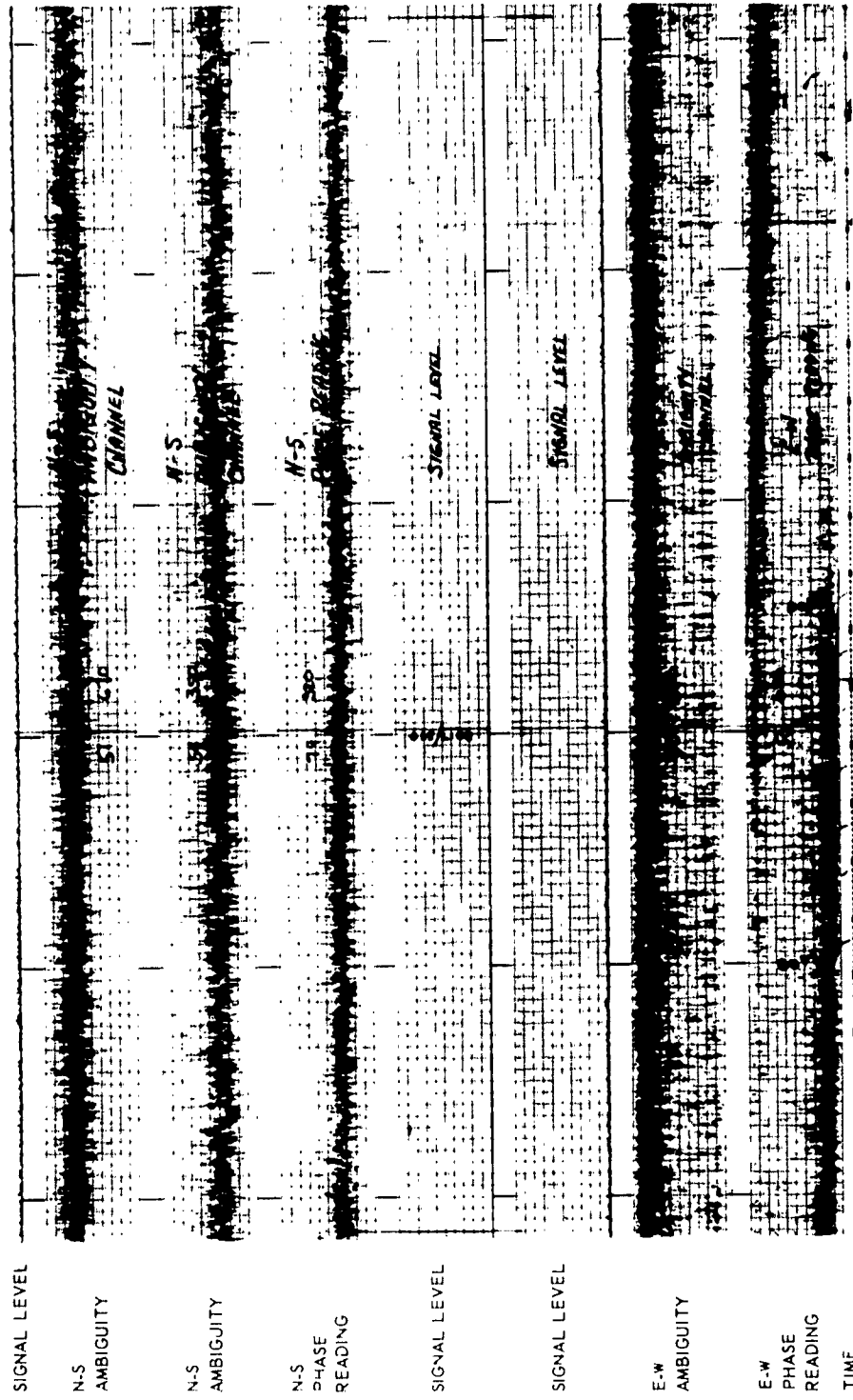

Figure 4 — Recording of a Cassiopeia A pass, November 29, 1960

This avoids the positional ambiguity of the star source which would be caused by other radiating objects within the field.

The records of the passes are sent to the Goddard Space Flight Center, Greenbelt, Maryland, for reduction. From the calibration constants of the Minitrack station and the internal drift values between calibrations, it is possible to determine what the phase reading will be when any 108-Mc source transits the meridian plane. The time when this reading is obtained is the actual transit time of the source. After the transit time is determined for the radio star pass, the apparent Right Ascension (RA) of the star is found by the following formula:

$$RA_{\text{Transit}} = GST_{0^{\text{h}}UT} - \lambda + (1 + K) GMT_{\text{Transit}},$$

where RA_{Transit} is the apparent Right Ascension at the time of transit, $GST_{0^{\text{h}}UT}$ is Greenwich Sidereal Time at 0 hours Universal Time and may be found for each day in the American Ephemeris and Nautical Almanac, λ is the west longitude of the station, and K is the factor used for conversion from mean solar to sidereal time (0.00273791). At the time of transit, the zenith angle in the meridian plane is determined from the north-south phase measurement and calibration constants. The Declination is the station latitude ϕ plus the zenith angle.

The mean Right Ascension and Declination on January 1, 1961.0 at 0^{h} Universal Time is then determined from the following formulas:

$$\alpha_0 = \alpha - \tau\mu - (Aa + Bb + Cc + Dd + E), \quad (1)$$

$$\delta_0 = \delta - \tau\mu' - (Aa' + Bb' + Cc' + Dd') \quad (2)$$

The terms α and δ are the apparent Right Ascension and apparent Declination, respectively, for the date of the record, at GMT_{Transit} . The quantities A, B, C, D and E are the Besselian Day Numbers for the date of the record, and these also are given for each day in the American Ephemeris and Nautical Almanac. The values for $\tau\mu$, the proper motion of the source in Right Ascension, $\tau\mu'$, the proper motion in Declination, and E are negligible. The quantities $a, b, c, d,$ and a', b', c', d' are Bessel's Star Constants and may be determined from the formulas given on page 506 of the 1960 Ephemeris.

As an example: for Cygnus A on November 23, 1960, the measured apparent α is $19^{\text{h}}58^{\text{m}}10^{\text{s}}.2$ and the apparent δ is $40^{\circ}37'55''.6\text{N}$, and from the preceding formulas, the mean α_0 and δ_0 for January 1, 1961.0 are calculated to be $19^{\text{h}}58^{\text{m}}11^{\text{s}}.4$ and $40^{\circ}37'36''.0\text{ N}$ respectively.

To compare the positions of the two radio stars as determined by Minitrack, with those determined by other experimenters (Reference 2), the 1961.0 mean place positions are reduced to an equinox of 1950.0. This may be done by a reduction for annual precession alone, since the secular variation for eleven years is less than 0.05 second of arc. For Right Ascension,

$$\alpha_{1950.0} = \alpha_{1961.0} - t(m + n \sin \alpha_0 \tan \delta_0) \quad (3)$$

where t is 11 years, m and n are the 1961.0 values (page 50 of the 1961 Ephemeris), and α_0 and δ_0 are the 1961.0 values. For Declination,

$$\delta_{1950.0} = \delta_{1961.0} - t(n \cos \alpha_0) \quad (4)$$

The following answers result:

$$\alpha_{1950.0} = 19^{\text{h}} 57^{\text{m}} 48.6 \quad (5)$$

$$\delta_{1950.0} = 40^{\circ} 35' 47.3 \quad (6)$$

In this manner, 56 passes of Cygnus A and 69 passes of Cassiopeia A were reduced to an equinox of 1950.0.

The average values of the Right Ascension and Declination of both sources, and the probable errors, are given in Table 3 and compared with the positions determined by other experimenters (Reference 2). Plots of the day to day variations in the determined positions of the two sources are shown in Figures 5 and 6.

Table 3
Comparison of Calculated Positions of Cygnus A and Cassiopeia A

Source	Position (1950 Epoch)		Frequency (Mc)
	Right Ascension	Declination	
Cygnus A	$19^{\text{h}}57^{\text{m}}45.3 \pm 1^{\text{s}}$	$+ 40^{\circ}35' \pm 1'$	100
	$19^{\text{h}}57^{\text{m}}44^{\text{s}} \pm 2-1/2^{\text{s}}$	$+ 40^{\circ}35' \pm 1-1/2'$	101
	$19^{\text{h}}57^{\text{m}}50^{\text{s}} \pm 4^{\text{s}}$	$+ 40^{\circ}35'.5 \pm 1'$	108 (Minitrack)
	$19^{\text{h}}57^{\text{m}}44.5$	$+ 40^{\circ}35'46.3$	Optical
Cassiopeia A	$23^{\text{h}}21^{\text{m}}12^{\text{s}} \pm 4^{\text{s}}$	$+ 58^{\circ}32'.0 \pm 1'$	108 (Minitrack)
	$23^{\text{h}}21^{\text{m}}12^{\text{s}} \pm 1^{\text{s}}$	$+ 58^{\circ}32'.1 \pm 0.7$	158
	$23^{\text{h}}21^{\text{m}}11.4$	$+ 58^{\circ}31'52.9$	Optical

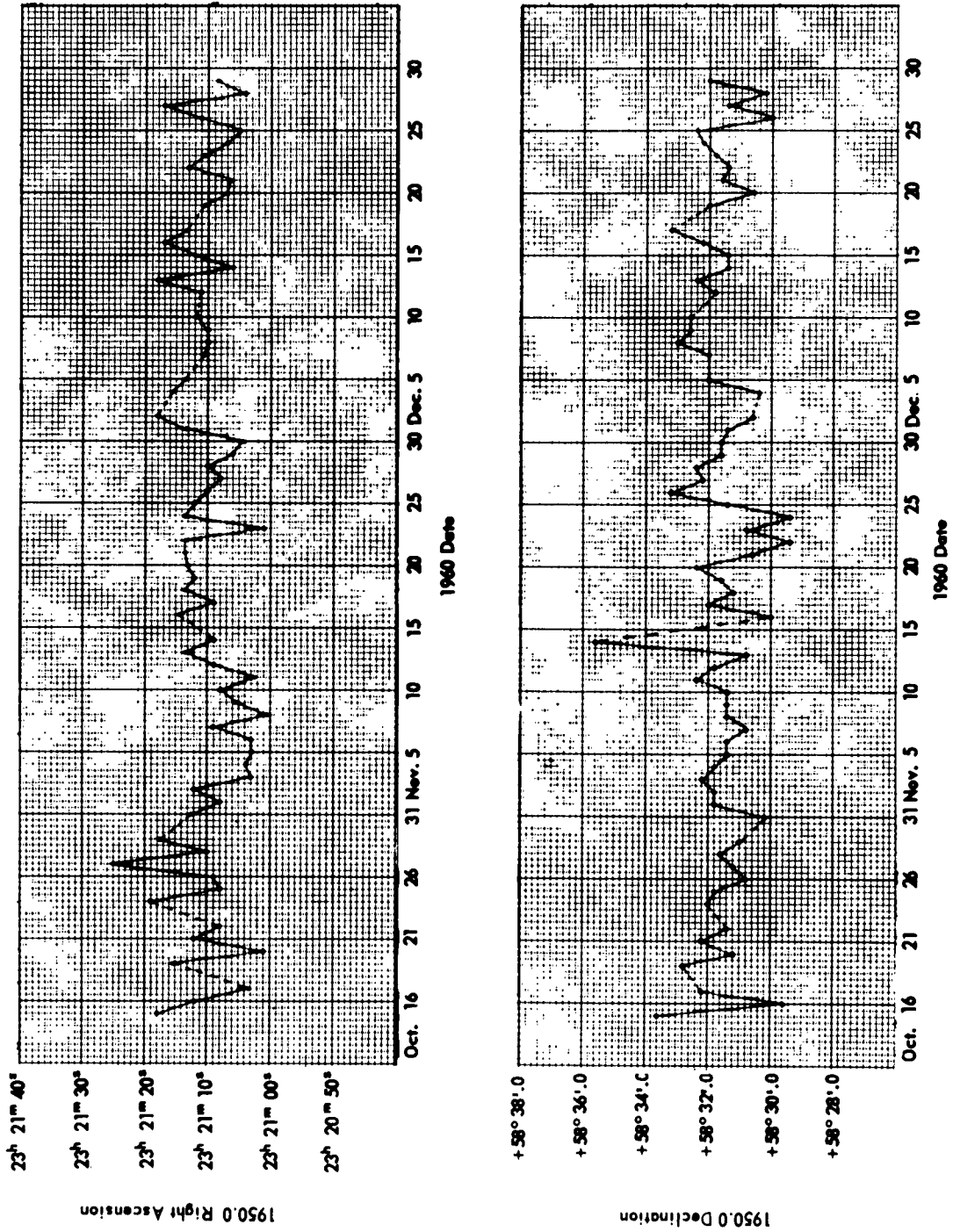

Figure 5 — Daily variations in the determination of the position of Cassiopeia A

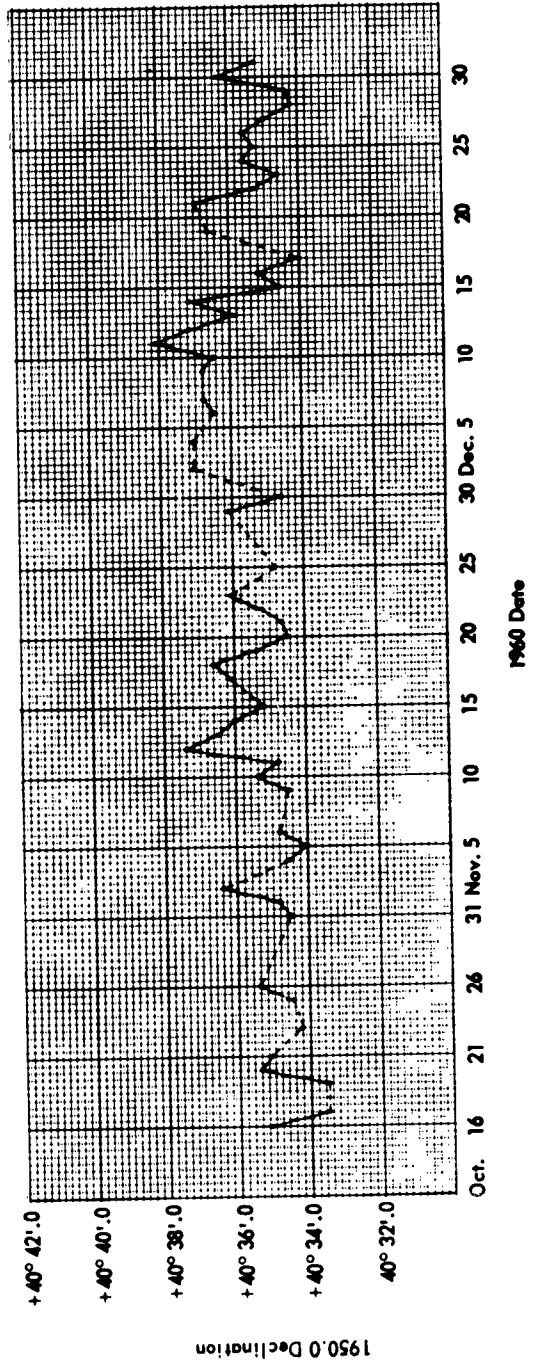
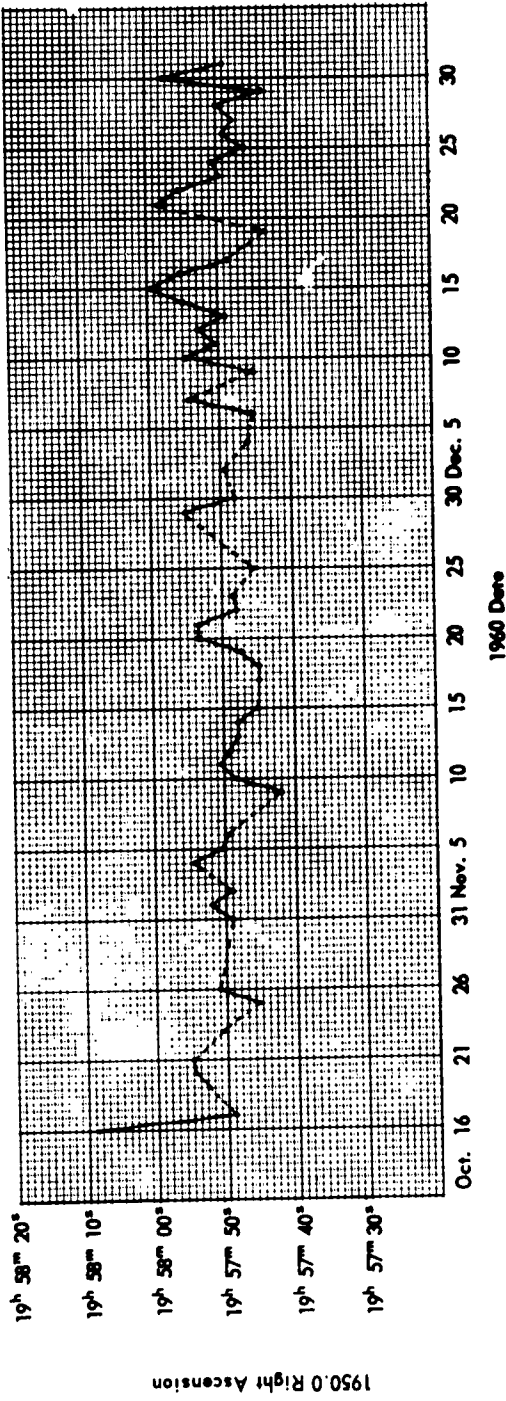

Figure 6 — Daily variations in the determination of the position of Cygnus A

RADIO REFRACTION AND SCINTILLATION

If earth curvature, wedge effects, and other variations of the ionosphere and atmosphere over the distance between the antenna pairs are disregarded, the two parallel radio paths coming into the antennas from a distant star will remain parallel. Under these conditions, the phase difference measured from the record will not be affected by the ionosphere or atmosphere, regardless of what the indices of refraction of these two media are.

Scintillation, or radio star twinkling, is caused by irregularities in the radio path. Fluctuations in intensity due to this are also irregular, appearing at times to be random and at other times quasi-periodic. In addition to the amplitude variations there are similar fluctuations in phase difference (Reference 4). However, because of the low signal level of these two sources and the low signal-to-noise ratio, amplitude variations due to the scintillation effect are hidden in the noise of the sky background and of the receiver system.

CONCLUSION

The positions and intensities of Cygnus A and Cassiopeia A at 108 Mc determined by the Minitrack System agree, within experimental error, with those determined by other experimenters. Since the positions do agree, these radio stars may be used for daily rough calibration of the Minitrack stations by comparing the observed positions with the predicted positions. A consistent difference between the observed and predicted positions at any station would indicate the need for an airplane calibration.

ACKNOWLEDGMENTS

The authors wish to thank Dr. Robert J. Coates and the members of the Systems Evaluation Branch of the Goddard Space Flight Center for their invaluable help and advice, and also Mr. Chester Mathes and his staff at the Ft. Myers Minitrack station for their cooperation.

REFERENCES

1. Pawsey, J. L., and Bracewell, R. N., "Radio Astronomy," Oxford: Clarendon Press, 1955, p. 250.
2. Pawsey, J. L., "A Catalogue of Reliably Known Discrete Sources of Cosmic Radio Waves," *Astrophys. J.*, 121(1):1-5, January 1955.
3. Wells, H. W., "Flux Measurements of Cassiopeia A and Cygnus A between 18.5 Mc and 107 Mc," *Proc. IRE* 46(1), January 1958, p. 207.
4. Pawsey, J. L., and Bracewell, R. N., *op. cit.*, pp. 347-351.

BIBLIOGRAPHY

- Booker, H. G., "The Use of Radio Stars to Study Irregular Refraction of Radio Waves in the Ionosphere," Proc. IRE 46(1):298-314, January 1958
- Brown, R., and Lovell, A. C. B., "The Exploration of Space by Radio," London: Chapman and Hall, Ltd., 1957
- Mengel, J. T., "Tracking the Earth Satellite, and Data Transmission, by Radio," Proc. IRE 44(6):755-760, June 1956
- National Aeronautics and Space Administration, "Minitrack System Training Manual," Revised Edition, September 1958
- Pawsey, J. L., "A Catalogue of Reliably Known Discrete Sources of Cosmic Radio Waves," Astrophys. J. 121(1):1-5, January 1955
- Pawsey, J. L., and Bracewell, R. N., "Radio Astronomy," Oxford: Clarendon Press, 1955
- Sloanaker, R. M., and Nichols, J. H., "Measurements of the Positions, Fluxes and Sizes of Celestial Radio Sources at 10.2 CM.," 1960, U. S. Naval Res. Lab. Rept. 5485, July 13, 1960

D-1122

<p>NASA TN D-1122 National Aeronautics and Space Administration. TRACKING OF CYGNUS A AND CASSIOPEIA A BY THE NASA 108-MC MINITRACK SYSTEM. E. J. Habib, J. H. Berbert, and D. W. Harris. March 1962. 13p. OTS price, \$0.50. (NASA TECHNICAL NOTE D-1122)</p> <p>Meridian transit passes of Cygnus A and Cassiopeia A are being recorded by the 108-Mc Minitrack system that was designed for precise satellite tracking. This paper covers the period from October 16, 1960, to December 31, 1960. The data were reduced to determine the flux densities and celestial positions of these two sources. The values obtained by this system are within the experi- mental error of those determined by other experi- menters on slightly different frequencies.</p>	<p>I. Habib, E. J. II. Berbert, J. H. III. Harris, D. W. IV. NASA TN D-1122</p> <p>(Initial NASA distribution: 6, Astronomy; 7, Astrophysics; 18, Communications and tracking installations, ground; 19, Electronics; 46, Space mechanics.)</p>	<p>NASA TN D-1122 National Aeronautics and Space Administration. TRACKING OF CYGNUS A AND CASSIOPEIA A BY THE NASA 108-MC MINITRACK SYSTEM. E. J. Habib, J. H. Berbert, and D. W. Harris. March 1962. 13p. OTS price, \$0.50. (NASA TECHNICAL NOTE D-1122)</p> <p>Meridian transit passes of Cygnus A and Cassiopeia A are being recorded by the 108-Mc Minitrack system that was designed for precise satellite tracking. This paper covers the period from October 16, 1960, to December 31, 1960. The data were reduced to determine the flux densities and celestial positions of these two sources. The values obtained by this system are within the experi- mental error of those determined by other experi- menters on slightly different frequencies.</p>	<p>I. Habib, E. J. II. Berbert, J. H. III. Harris, D. W. IV. NASA TN D-1122</p> <p>(Initial NASA distribution: 6, Astronomy; 7, Astrophysics; 18, Communications and tracking installations, ground; 19, Electronics; 46, Space mechanics.)</p>	<p>NASA Copies obtainable from NASA, Washington</p>
<p>NASA TN D-1122 National Aeronautics and Space Administration. TRACKING OF CYGNUS A AND CASSIOPEIA A BY THE NASA 108-MC MINITRACK SYSTEM. E. J. Habib, J. H. Berbert, and D. W. Harris. March 1962. 13p. OTS price, \$0.50. (NASA TECHNICAL NOTE D-1122)</p> <p>Meridian transit passes of Cygnus A and Cassiopeia A are being recorded by the 108-Mc Minitrack system that was designed for precise satellite tracking. This paper covers the period from October 16, 1960, to December 31, 1960. The data were reduced to determine the flux densities and celestial positions of these two sources. The values obtained by this system are within the experi- mental error of those determined by other experi- menters on slightly different frequencies.</p>	<p>I. Habib, E. J. II. Berbert, J. H. III. Harris, D. W. IV. NASA TN D-1122</p> <p>(Initial NASA distribution: 6, Astronomy; 7, Astrophysics; 18, Communications and tracking installations, ground; 19, Electronics; 46, Space mechanics.)</p>	<p>NASA TN D-1122 National Aeronautics and Space Administration. TRACKING OF CYGNUS A AND CASSIOPEIA A BY THE NASA 108-MC MINITRACK SYSTEM. E. J. Habib, J. H. Berbert, and D. W. Harris. March 1962. 13p. OTS price, \$0.50. (NASA TECHNICAL NOTE D-1122)</p> <p>Meridian transit passes of Cygnus A and Cassiopeia A are being recorded by the 108-Mc Minitrack system that was designed for precise satellite tracking. This paper covers the period from October 16, 1960, to December 31, 1960. The data were reduced to determine the flux densities and celestial positions of these two sources. The values obtained by this system are within the experi- mental error of those determined by other experi- menters on slightly different frequencies.</p>	<p>I. Habib, E. J. II. Berbert, J. H. III. Harris, D. W. IV. NASA TN D-1122</p> <p>(Initial NASA distribution: 6, Astronomy; 7, Astrophysics; 18, Communications and tracking installations, ground; 19, Electronics; 46, Space mechanics.)</p>	<p>NASA Copies obtainable from NASA, Washington</p>
<p>NASA TN D-1122 National Aeronautics and Space Administration. TRACKING OF CYGNUS A AND CASSIOPEIA A BY THE NASA 108-MC MINITRACK SYSTEM. E. J. Habib, J. H. Berbert, and D. W. Harris. March 1962. 13p. OTS price, \$0.50. (NASA TECHNICAL NOTE D-1122)</p> <p>Meridian transit passes of Cygnus A and Cassiopeia A are being recorded by the 108-Mc Minitrack system that was designed for precise satellite tracking. This paper covers the period from October 16, 1960, to December 31, 1960. The data were reduced to determine the flux densities and celestial positions of these two sources. The values obtained by this system are within the experi- mental error of those determined by other experi- menters on slightly different frequencies.</p>	<p>I. Habib, E. J. II. Berbert, J. H. III. Harris, D. W. IV. NASA TN D-1122</p> <p>(Initial NASA distribution: 6, Astronomy; 7, Astrophysics; 18, Communications and tracking installations, ground; 19, Electronics; 46, Space mechanics.)</p>	<p>NASA TN D-1122 National Aeronautics and Space Administration. TRACKING OF CYGNUS A AND CASSIOPEIA A BY THE NASA 108-MC MINITRACK SYSTEM. E. J. Habib, J. H. Berbert, and D. W. Harris. March 1962. 13p. OTS price, \$0.50. (NASA TECHNICAL NOTE D-1122)</p> <p>Meridian transit passes of Cygnus A and Cassiopeia A are being recorded by the 108-Mc Minitrack system that was designed for precise satellite tracking. This paper covers the period from October 16, 1960, to December 31, 1960. The data were reduced to determine the flux densities and celestial positions of these two sources. The values obtained by this system are within the experi- mental error of those determined by other experi- menters on slightly different frequencies.</p>	<p>I. Habib, E. J. II. Berbert, J. H. III. Harris, D. W. IV. NASA TN D-1122</p> <p>(Initial NASA distribution: 6, Astronomy; 7, Astrophysics; 18, Communications and tracking installations, ground; 19, Electronics; 46, Space mechanics.)</p>	<p>NASA Copies obtainable from NASA, Washington</p>

<p>NASA TN D-1122 National Aeronautics and Space Administration. TRACKING OF CYGNUS A AND CASSIOPEIA A BY THE NASA 108-MC MINITRACK SYSTEM. E. J. Habib, J. H. Berbert, and D. W. Harris. March 1962. 13p. OTS price, \$0.50. (NASA TECHNICAL NOTE D-1122)</p> <p>Meridian transit passes of Cygnus A and Cassiopeia A are being recorded by the 108-Mc Minitrack system that was designed for precise satellite tracking. This paper covers the period from October 16, 1960, to December 31, 1960. The data were reduced to determine the flux densities and celestial positions of these two sources. The values obtained by this system are within the experi- mental error of those determined by other experi- menters on slightly different frequencies.</p>	<p>I. Habib, E. J. II. Berbert, J. H. III. Harris, D. W. IV. NASA TN D-1122</p> <p>(Initial NASA distribution: 6, Astronomy; 7, Astrophysics; 18, Communications and tracking installations, ground; 19, Electronics; 46, Space mechanics.)</p>	<p>NASA TN D-1122 National Aeronautics and Space Administration. TRACKING OF CYGNUS A AND CASSIOPEIA A BY THE NASA 108-MC MINITRACK SYSTEM. E. J. Habib, J. H. Berbert, and D. W. Harris. March 1962. 13p. OTS price, \$0.50. (NASA TECHNICAL NOTE D-1122)</p> <p>Meridian transit passes of Cygnus A and Cassiopeia A are being recorded by the 108-Mc Minitrack system that was designed for precise satellite tracking. This paper covers the period from October 16, 1960, to December 31, 1960. The data were reduced to determine the flux densities and celestial positions of these two sources. The values obtained by this system are within the experi- mental error of those determined by other experi- menters on slightly different frequencies.</p>
<p>NASA TN D-1122 National Aeronautics and Space Administration. TRACKING OF CYGNUS A AND CASSIOPEIA A BY THE NASA 108-MC MINITRACK SYSTEM. E. J. Habib, J. H. Berbert, and D. W. Harris. March 1962. 13p. OTS price, \$0.50. (NASA TECHNICAL NOTE D-1122)</p> <p>Meridian transit passes of Cygnus A and Cassiopeia A are being recorded by the 108-Mc Minitrack system that was designed for precise satellite tracking. This paper covers the period from October 16, 1960, to December 31, 1960. The data were reduced to determine the flux densities and celestial positions of these two sources. The values obtained by this system are within the experi- mental error of those determined by other experi- menters on slightly different frequencies.</p>	<p>I. Habib, E. J. II. Berbert, J. H. III. Harris, D. W. IV. NASA TN D-1122</p> <p>(Initial NASA distribution: 6, Astronomy; 7, Astrophysics; 18, Communications and tracking installations, ground; 19, Electronics; 46, Space mechanics.)</p>	<p>NASA TN D-1122 National Aeronautics and Space Administration. TRACKING OF CYGNUS A AND CASSIOPEIA A BY THE NASA 108-MC MINITRACK SYSTEM. E. J. Habib, J. H. Berbert, and D. W. Harris. March 1962. 13p. OTS price, \$0.50. (NASA TECHNICAL NOTE D-1122)</p> <p>Meridian transit passes of Cygnus A and Cassiopeia A are being recorded by the 108-Mc Minitrack system that was designed for precise satellite tracking. This paper covers the period from October 16, 1960, to December 31, 1960. The data were reduced to determine the flux densities and celestial positions of these two sources. The values obtained by this system are within the experi- mental error of those determined by other experi- menters on slightly different frequencies.</p>
<p>NASA TN D-1122 National Aeronautics and Space Administration. TRACKING OF CYGNUS A AND CASSIOPEIA A BY THE NASA 108-MC MINITRACK SYSTEM. E. J. Habib, J. H. Berbert, and D. W. Harris. March 1962. 13p. OTS price, \$0.50. (NASA TECHNICAL NOTE D-1122)</p> <p>Meridian transit passes of Cygnus A and Cassiopeia A are being recorded by the 108-Mc Minitrack system that was designed for precise satellite tracking. This paper covers the period from October 16, 1960, to December 31, 1960. The data were reduced to determine the flux densities and celestial positions of these two sources. The values obtained by this system are within the experi- mental error of those determined by other experi- menters on slightly different frequencies.</p>	<p>I. Habib, E. J. II. Berbert, J. H. III. Harris, D. W. IV. NASA TN D-1122</p> <p>(Initial NASA distribution: 6, Astronomy; 7, Astrophysics; 18, Communications and tracking installations, ground; 19, Electronics; 46, Space mechanics.)</p>	<p>NASA TN D-1122 National Aeronautics and Space Administration. TRACKING OF CYGNUS A AND CASSIOPEIA A BY THE NASA 108-MC MINITRACK SYSTEM. E. J. Habib, J. H. Berbert, and D. W. Harris. March 1962. 13p. OTS price, \$0.50. (NASA TECHNICAL NOTE D-1122)</p> <p>Meridian transit passes of Cygnus A and Cassiopeia A are being recorded by the 108-Mc Minitrack system that was designed for precise satellite tracking. This paper covers the period from October 16, 1960, to December 31, 1960. The data were reduced to determine the flux densities and celestial positions of these two sources. The values obtained by this system are within the experi- mental error of those determined by other experi- menters on slightly different frequencies.</p>
<p>NASA TN D-1122 National Aeronautics and Space Administration. TRACKING OF CYGNUS A AND CASSIOPEIA A BY THE NASA 108-MC MINITRACK SYSTEM. E. J. Habib, J. H. Berbert, and D. W. Harris. March 1962. 13p. OTS price, \$0.50. (NASA TECHNICAL NOTE D-1122)</p> <p>Meridian transit passes of Cygnus A and Cassiopeia A are being recorded by the 108-Mc Minitrack system that was designed for precise satellite tracking. This paper covers the period from October 16, 1960, to December 31, 1960. The data were reduced to determine the flux densities and celestial positions of these two sources. The values obtained by this system are within the experi- mental error of those determined by other experi- menters on slightly different frequencies.</p>	<p>I. Habib, E. J. II. Berbert, J. H. III. Harris, D. W. IV. NASA TN D-1122</p> <p>(Initial NASA distribution: 6, Astronomy; 7, Astrophysics; 18, Communications and tracking installations, ground; 19, Electronics; 46, Space mechanics.)</p>	<p>NASA TN D-1122 National Aeronautics and Space Administration. TRACKING OF CYGNUS A AND CASSIOPEIA A BY THE NASA 108-MC MINITRACK SYSTEM. E. J. Habib, J. H. Berbert, and D. W. Harris. March 1962. 13p. OTS price, \$0.50. (NASA TECHNICAL NOTE D-1122)</p> <p>Meridian transit passes of Cygnus A and Cassiopeia A are being recorded by the 108-Mc Minitrack system that was designed for precise satellite tracking. This paper covers the period from October 16, 1960, to December 31, 1960. The data were reduced to determine the flux densities and celestial positions of these two sources. The values obtained by this system are within the experi- mental error of those determined by other experi- menters on slightly different frequencies.</p>

NASA

Copies obtainable from NASA, Washington

NASA

Copies obtainable from NASA, Washington

NASA

NASA

Copies obtainable from NASA, Washington

NASA

Copies obtainable from NASA, Washington

NASA

<p>NASA TN D-1122 National Aeronautics and Space Administration. TRACKING OF CYGNUS A AND CASSIOPEIA A BY THE NASA 108-MC MINITRACK SYSTEM. E. J. Habib, J. H. Berbert, and D. W. Harris. March 1962. 13p. OTS price, \$0.50. (NASA TECHNICAL NOTE D-1122)</p> <p>Meridian transit passes of Cygnus A and Cassiopeia A are being recorded by the 108-Mc Minitrack system that was designed for precise satellite tracking. This paper covers the period from October 16, 1960, to December 31, 1960. The data were reduced to determine the flux densities and celestial positions of these two sources. The values obtained by this system are within the experi- mental error of those determined by other experi- menters on slightly different frequencies.</p>	<p>I. Habib, E. J. II. Berbert, J. H. III. Harris, D. W. IV. NASA TN D-1122</p> <p>(Initial NASA distribution: 6, Astronomy; 7, Astrophysics; 18, Communications and tracking installations, ground; 19, Electronics; 46, Space mechanics.)</p>	<p>NASA TN D-1122 National Aeronautics and Space Administration. TRACKING OF CYGNUS A AND CASSIOPEIA A BY THE NASA 108-MC MINITRACK SYSTEM. E. J. Habib, J. H. Berbert, and D. W. Harris. March 1962. 13p. OTS price, \$0.50. (NASA TECHNICAL NOTE D-1122)</p> <p>Meridian transit passes of Cygnus A and Cassiopeia A are being recorded by the 108-Mc Minitrack system that was designed for precise satellite tracking. This paper covers the period from October 16, 1960, to December 31, 1960. The data were reduced to determine the flux densities and celestial positions of these two sources. The values obtained by this system are within the experi- mental error of those determined by other experi- menters on slightly different frequencies.</p>	<p>I. Habib, E. J. II. Berbert, J. H. III. Harris, D. W. IV. NASA TN D-1122</p> <p>(Initial NASA distribution: 6, Astronomy; 7, Astrophysics; 18, Communications and tracking installations, ground; 19, Electronics; 46, Space mechanics.)</p>
<p>NASA TN D-1122 National Aeronautics and Space Administration. TRACKING OF CYGNUS A AND CASSIOPEIA A BY THE NASA 108-MC MINITRACK SYSTEM. E. J. Habib, J. H. Berbert, and D. W. Harris. March 1962. 13p. OTS price, \$0.50. (NASA TECHNICAL NOTE D-1122)</p> <p>Meridian transit passes of Cygnus A and Cassiopeia A are being recorded by the 108-Mc Minitrack system that was designed for precise satellite tracking. This paper covers the period from October 16, 1960, to December 31, 1960. The data were reduced to determine the flux densities and celestial positions of these two sources. The values obtained by this system are within the experi- mental error of those determined by other experi- menters on slightly different frequencies.</p>	<p>I. Habib, E. J. II. Berbert, J. H. III. Harris, D. W. IV. NASA TN D-1122</p> <p>(Initial NASA distribution: 6, Astronomy; 7, Astrophysics; 18, Communications and tracking installations, ground; 19, Electronics; 46, Space mechanics.)</p>	<p>NASA TN D-1122 National Aeronautics and Space Administration. TRACKING OF CYGNUS A AND CASSIOPEIA A BY THE NASA 108-MC MINITRACK SYSTEM. E. J. Habib, J. H. Berbert, and D. W. Harris. March 1962. 13p. OTS price, \$0.50. (NASA TECHNICAL NOTE D-1122)</p> <p>Meridian transit passes of Cygnus A and Cassiopeia A are being recorded by the 108-Mc Minitrack system that was designed for precise satellite tracking. This paper covers the period from October 16, 1960, to December 31, 1960. The data were reduced to determine the flux densities and celestial positions of these two sources. The values obtained by this system are within the experi- mental error of those determined by other experi- menters on slightly different frequencies.</p>	<p>I. Habib, E. J. II. Berbert, J. H. III. Harris, D. W. IV. NASA TN D-1122</p> <p>(Initial NASA distribution: 6, Astronomy; 7, Astrophysics; 18, Communications and tracking installations, ground; 19, Electronics; 46, Space mechanics.)</p>
<p>NASA TN D-1122 National Aeronautics and Space Administration. TRACKING OF CYGNUS A AND CASSIOPEIA A BY THE NASA 108-MC MINITRACK SYSTEM. E. J. Habib, J. H. Berbert, and D. W. Harris. March 1962. 13p. OTS price, \$0.50. (NASA TECHNICAL NOTE D-1122)</p> <p>Meridian transit passes of Cygnus A and Cassiopeia A are being recorded by the 108-Mc Minitrack system that was designed for precise satellite tracking. This paper covers the period from October 16, 1960, to December 31, 1960. The data were reduced to determine the flux densities and celestial positions of these two sources. The values obtained by this system are within the experi- mental error of those determined by other experi- menters on slightly different frequencies.</p>	<p>I. Habib, E. J. II. Berbert, J. H. III. Harris, D. W. IV. NASA TN D-1122</p> <p>(Initial NASA distribution: 6, Astronomy; 7, Astrophysics; 18, Communications and tracking installations, ground; 19, Electronics; 46, Space mechanics.)</p>	<p>NASA TN D-1122 National Aeronautics and Space Administration. TRACKING OF CYGNUS A AND CASSIOPEIA A BY THE NASA 108-MC MINITRACK SYSTEM. E. J. Habib, J. H. Berbert, and D. W. Harris. March 1962. 13p. OTS price, \$0.50. (NASA TECHNICAL NOTE D-1122)</p> <p>Meridian transit passes of Cygnus A and Cassiopeia A are being recorded by the 108-Mc Minitrack system that was designed for precise satellite tracking. This paper covers the period from October 16, 1960, to December 31, 1960. The data were reduced to determine the flux densities and celestial positions of these two sources. The values obtained by this system are within the experi- mental error of those determined by other experi- menters on slightly different frequencies.</p>	<p>I. Habib, E. J. II. Berbert, J. H. III. Harris, D. W. IV. NASA TN D-1122</p> <p>(Initial NASA distribution: 6, Astronomy; 7, Astrophysics; 18, Communications and tracking installations, ground; 19, Electronics; 46, Space mechanics.)</p>

NASA

Copies obtainable from NASA, Washington

NASA

Copies obtainable from NASA, Washington

NASA

NASA

Copies obtainable from NASA, Washington

NASA

Copies obtainable from NASA, Washington

NASA