

UNCLASSIFIED

AD 258 735

*Reproduced
by the*

ARMED SERVICES TECHNICAL INFORMATION AGENCY
ARLINGTON HALL STATION
ARLINGTON 12, VIRGINIA



UNCLASSIFIED

NOTICE: When government or other drawings, specifications or other data are used for any purpose other than in connection with a definitely related government procurement operation, the U. S. Government thereby incurs no responsibility, nor any obligation whatsoever; and the fact that the Government may have formulated, furnished, or in any way supplied the said drawings, specifications, or other data is not to be regarded by implication or otherwise as in any manner licensing the holder or any other person or corporation, or conveying any rights or permission to manufacture, use or sell any patented invention that may in any way be related thereto.



**BUREAU OF
RESEARCH AND DEVELOPMENT**

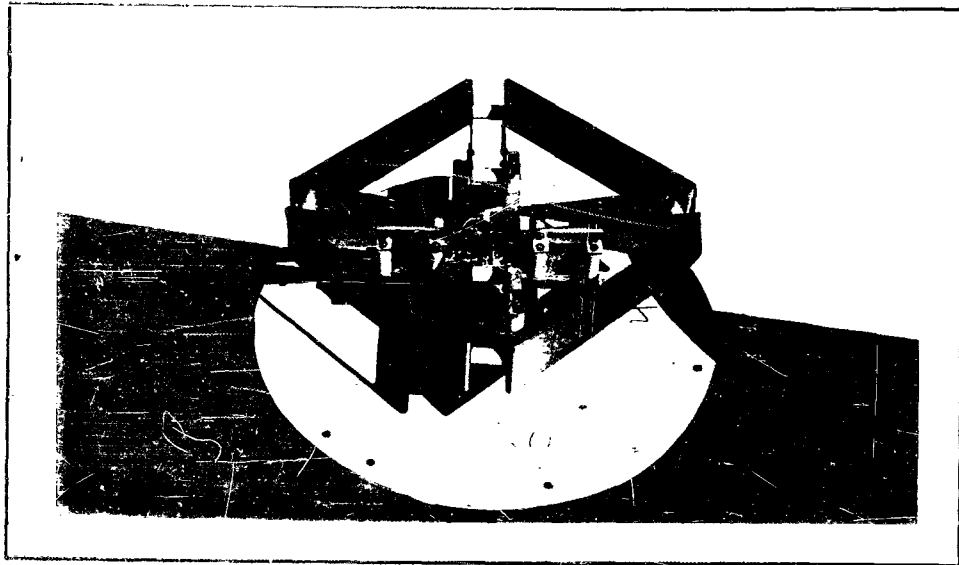

FINAL REPORT

MODIFICATION OF STANDARD ALFORD LOOP
ANTENNA FOR USE ON DOPPLER VOR

FEBRUARY 1961

Prepared by

TEST AND EXPERIMENTATION DIVISION
Atlantic City New Jersey

MODIFICATION OF STANDARD ALFORD LOOP

ANTENNA FOR USE ON DOPPLER VOR

TASK No. 115-02-06T (D-1-5142C)

PREPARED BY:

S. E. Taggart
Test & Experimentation Division

This report has been reviewed and is approved for distribution.

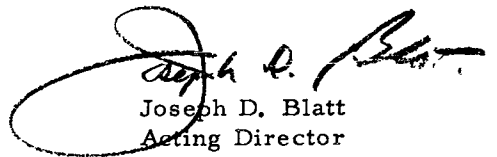

Joseph D. Blatt
Acting Director
Bureau of Research & Development
Federal Aviation Agency

TABLE OF CONTENTS

	Page
ABSTRACT	iii
PURPOSE	iv
SUMMARY	iv
INTRODUCTION	1
DISCUSSION	2
CONCLUSIONS	6

LIST OF ILLUSTRATIONS

	Figure
Doppler VOR Antennas Modified with Ceramic Blocks - Transmission Line Crossovers Oriented Oppositely	1
Doppler VOR Antennas Modified with Parallel Plate Capacitors - Transmission Line Crossovers Oriented Oppositely	2
Test Arrangement for Measuring Reduction in Loop Parasitic Currents as a Result of Loop Modification	3
Doppler VOR Antennas Modified with Parallel Plate Capacitors - Transmission Line Crossovers Oriented Alike	4
Effect of Capacitor Plate Spacing on Parasitic Currents and VSWR in Loop Antennas of the Doppler VOR	5
Effect of Transmission Line Length on Parasitic Currents in Loop Antennas of the Doppler VOR	6
Modification of Alford Band "B" Loop for Reduction of Parasitic Currents - NAFEC Doppler VOR	7

ABSTRACT

The standard Alford loops used in the Doppler VOR antenna array were modified and tests conducted to determine the reduction in parasitic current achieved as a result of the modification.

PURPOSE

The purpose of this task assignment was to modify a standard Alford loop antenna to reduce parasitic currents when used on the Doppler VOR.

SUMMARY

An investigation was conducted to determine a suitable and expeditious modification for a standard Alford loop antenna to reduce parasitic currents when the loop is used in the antenna array of the Doppler VOR.

INTRODUCTION

When two or more antennas, tuned to approximately the same frequency, are placed near each other, some mutual coupling will exist between them. If radio frequency (r-f) power is supplied to any one of the antennas in the group, current will flow in each of the other antennas. The amount of current which will flow depends upon the relative spacing, orientation, and tuning of the antennas, as well as other factors. This current, called parasitic current, is very useful in many types of directive antenna arrays, but may be extremely undesirable and troublesome if the array is used with an air navigation facility. When current flows in any antenna, power is radiated, and the resultant field, whether it is produced by parasitic current or produced by current flowing in an antenna to which power has been intentionally supplied, modifies the overall field pattern of the array. Usually, when an array is designed for use with a navigational aid, the effect of parasitic currents is not considered, even though the presence of such currents may influence the performance of the facility adversely. The standard Federal Aviation Agency (FAA) localizer antenna array can serve to illustrate this point.

This array consists of a row of eight horizontally polarized loop antennas with the two center antennas operated in phase and supplied with r-f carrier power. The remaining six antennas are supplied with sideband power and are operated as out-of-phase pairs symmetrically disposed on each side of the two carrier antennas. Because of the proximity of the sideband antennas to the carrier antennas, parasitic currents, which are relatively large with respect to the actual sideband currents, may flow in the various sideband antennas. When this occurs, the overall r-f sideband pattern is modified in such a manner that the localizer courses are no longer well-defined and clearance at certain azimuths may be considerably reduced. It has long been known that, if the tielines between a given pair of localizer sideband antennas were cut to certain lengths, the parasitic current in one sideband antenna could be used to cancel the parasitic current in the other sideband antenna. When the various antenna tielines in a localizer array are cut very carefully to these required lengths, parasitic currents are reduced to negligible values and the overall r-f pattern of the array closely approaches the theoretical pattern.

Unfortunately, reduction of parasitic current by cancellation is not possible in all types of antenna arrays. The Doppler VOR array is a good example of an array where reduction of parasitic currents flowing in passive elements is not easily accomplished by cancellation techniques. The Doppler VOR array consists of 50 loop antennas equally spaced on a circle 44 feet in diameter. Thus, the individual antennas are 33.2 inches or 111.4 electrical degrees apart at 115 megacycles.

As a result of this close spacing, parasitic currents in antennas adjacent to the one being fed at any given instant may be relatively high, and antennas four or five spaces distant from a driven antenna can exhibit amounts of parasitic current easily measurable by conventional methods. Even though the parasitic currents may be low in terms of conventional measurement units, they still can be high with respect to the current in the driven antenna. These parasitic currents can greatly modify the rotating sideband patterns of the Doppler VOR. Inasmuch as it is the sideband pattern which supplies the actual bearing information, it is desirable to have this pattern as free of distortion as the state-of-the-art permits.

While it may be possible to employ cancellation techniques as a means of reducing parasitic current in the sideband antennas of the Doppler VOR, this method has not yet been fully explored. The method presently used, and the method upon which the modification discussed in this report are based, depend on placing an electrical short across the terminals of any given loop during the period of time that it is not being driven intentionally.

DISCUSSION

a. Initial Loop Modification. When this task was initially assigned, an early completion date was requested so that other work on the Doppler VOR could be started. A modification for reducing parasitic currents in the loop antennas of the Doppler VOR was suggested in the task assignment. The proposed modification would have required extensive mechanical modification of the loops. This would have been time-consuming. As a consequence, a more expeditious method of obtaining the desired result was sought. It was reasoned that by placing dielectric material in the open transmission line portions of a loop, the same end result should be achieved as with the proposed modification. This proved successful and a

temporary modification, using ceramic blocks as shown in Fig. 1, was made. It also was determined at this time that a further reduction in parasitic current could be obtained by orienting the loops so that the transmission line portions of the loops were all in line with the periphery of a circle through the center of the loops and with alternate loops oriented so that the transmission line crossovers alternated on either side of the loop center (Fig. 1). The results obtained with this modification were previously reported in a National Aviation Facilities Experimental Center (NAFEC) letter report, titled "Modification of Standard Alford Loop Antenna for Use on Doppler VOR," dated January 5, 1960.

b. Final Loop Modification. To make the temporary modification of Fig. 1 permanent would have required that the ceramic block inserts be replaced by blocks shaped for the application and provided with suitable mounting lugs. It also would have been necessary for the replacement inserts to be made of material with electrical characteristics similar to those of the units employed for the temporary modification. Because of the prohibitive cost of a relatively small number of special inserts and the delay entailed in their fabrication, it was necessary to consider other methods of reducing loop parasitic current.

Capacitively tuning the transmission line portions of the individual loops had the most appeal, primarily because of simplicity and ease of modification. Accordingly, a small capacitor made of two 3-inch aluminum discs was mounted in each transmission line portion of five of the Alford loops in the Doppler VOR antenna array (Fig. 2).

The five feed lines associated with the modified loops were disconnected from the distributor and the line leading to the center loop was fed with r-f power from the VOR transmitter through a slotted line. The remaining four lines each were connected to an r-f phaser or "line stretcher" (Fig. 3). It should be noted at this point that all feed lines had been pruned previously so that all lines terminating on the distributor were of the same electrical length, and of the electrical length for producing minimum parasitic currents. The r-f phasers were added to simulate various lengths of feed line on the loops and to compensate for the effect of the r-f distributor on the electrical length of the feed lines.

The spacing of the capacitor plates on each loop was varied in 1/8-inch steps between 1/4-inch and 1 inch. The four phasers were changed in 10° or smaller steps over 80 per cent of their range for each spacing of the capacitor plates. Currents were read in all four faces of each loop. Parasitic current was expressed as the relation between the sum of the currents in the four faces of the driven loop to half the sum of the currents in the eight faces of the first adjacent pair of loops or the eight faces of the second adjacent pair of loops. When a given set of values was taken, all condensers were spaced the same and all phasers were set the same. Additional data were taken with all condensers removed and also with ceramic blocks inserted as described in the earlier letter report. Voltage standing wave ratio (VSWR) readings were taken in the feed line to the excited antenna for each condition. Similar tests also were made with loops 2 and 4 (Fig. 3) rotated 180° on their mounting pedestals so that all the crossovers at the center of the loops were on the same side of the feed point as shown in Fig. 4.

The data collected for determining optimum capacitor plate spacing are presented in Fig. 5. The data shown in Fig. 5 were obtained with loop transmission line crossovers oriented for minimum parasitic current, as discussed previously. The data from all tests were summarized and are presented in Table I.

TABLE I
MINIMUM PARASITIC CURRENTS

<u>Condition of Test</u>	<u>Parasitic Current - Per Cent</u>		<u>VSWR</u>
	<u>1st Adj. Pair</u>	<u>2nd Adj. Pair</u>	
Loops Unmodified			
Alternate Loops Rotated	5.2	2.2	5.7
Ceramic Blocks			
Loops Oriented Alike	3.5	0.9	2.4
Ceramic Blocks			
Alternate Loops Rotated	2.8	0.8	2.4
Capacitor 1/2-Inch Plate Spacing			
Loops Oriented Alike	3.6	1.1	2.6
Capacitor 1/2-Inch Plate Spacing			
Alternate Loops Rotated	2.6	0.8	2.6

The results of varying the length of transmission lines feeding the loops are presented in Fig. 6. The results of this test verified that all lines had been cut to the optimum length, in this case 2740 electrical degrees $\left(\frac{15\lambda}{2} + 40^\circ\right)$.

Although the percentages of observed parasitic current noted in Table I should be easily obtained with approximately the lengths of transmission line used during these tests, considerable possibility for variation from these values exists because of the effect of temperature variation on the feed lines. Based on data obtained during previous tests¹ made to determine the effect of temperature on the electrical length of RG-8/U transmission line, a temperature change of approximately 9° F. will produce a change of 1 electrical degree in a 43-foot length of line, approximately the length of line attached to each loop in a Doppler VOR antenna array. Therefore, a significant change in parasitic currents could occur during large variations in ambient temperature unless, at the time of final pruning, the transmission lines were cut to the optimum length at the center of the expected range of ambient temperatures.

All loops of the NAFEC Doppler VOR were modified subsequently as detailed in Fig. 7 and the capacitor plates adjusted to a 1/2-inch spacing.

¹Samuel E. Taggart, Oliver J. DeZoute, and Walter M. Ehler, "The CAA Directional Localizer," Technical Development Report No. 367, August 1958.

CONCLUSIONS

It is concluded that:

1. The parasitic currents in the Alford loops of the Doppler VOR antenna array can be reduced appreciably by tuning the transmission line portions of the individual loops with a parallel plate capacitor. A further reduction in parasitic current can be effected by positioning the loops so that the transmission line crossovers are in line with the periphery of a circle through the centers of the loops and by alternating crossovers on either side of loop centers.

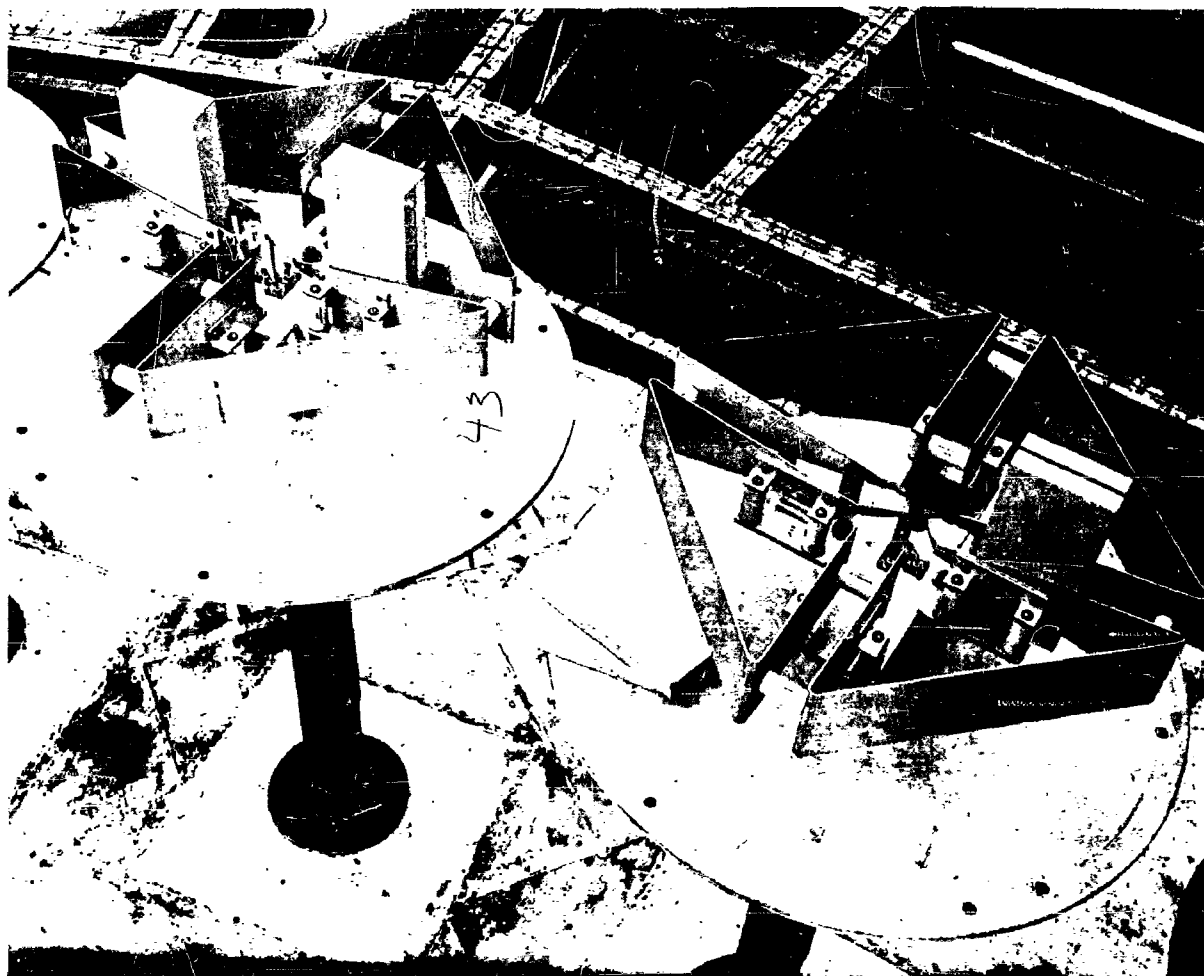

DOPPLER VOR ANTENNAS MODIFIED WITH
CERAMIC BLOCKS—TRANSMISSION LINE
CROSSOVERS ORIENTED OPPOSITELY

Task No. 115-02-06T

FIG. 1



**DOPPLER VOR ANTENNAS MODIFIED WITH
PARALLEL PLATE CAPACITORS—TRANSMISSION
LINE CROSSOVERS ORIENTED OPPOSITELY**

Task No. 115-02-06T

FIG. 2

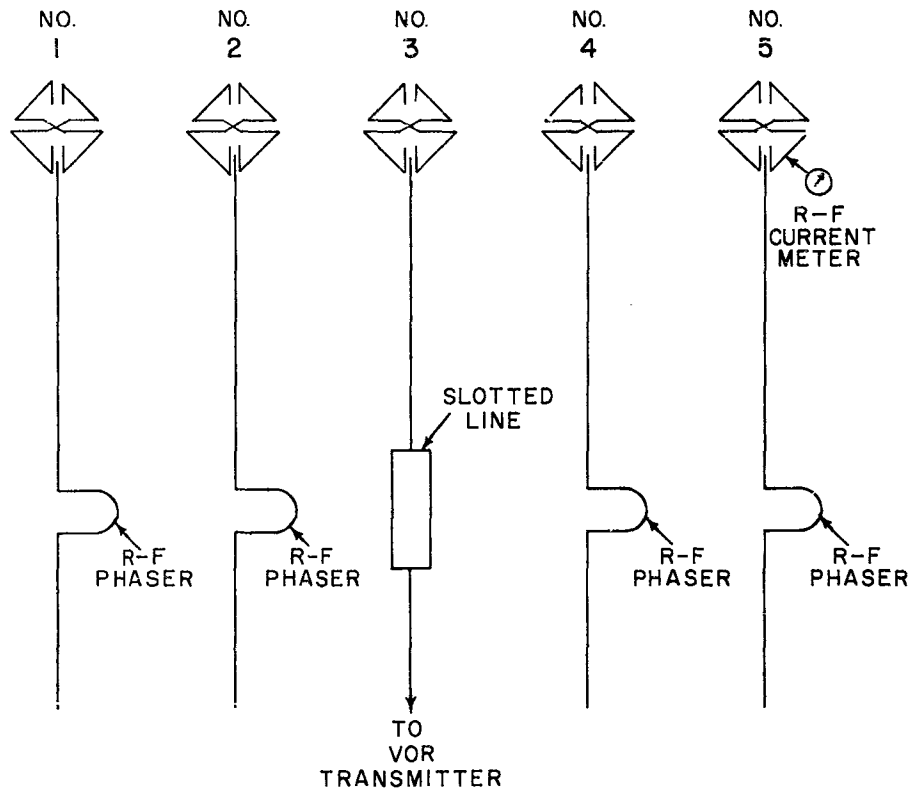

TEST ARRANGEMENT FOR MEASURING
REDUCTION IN LOOP PARASITIC CURRENTS
AS A RESULT OF LOOP MODIFICATION

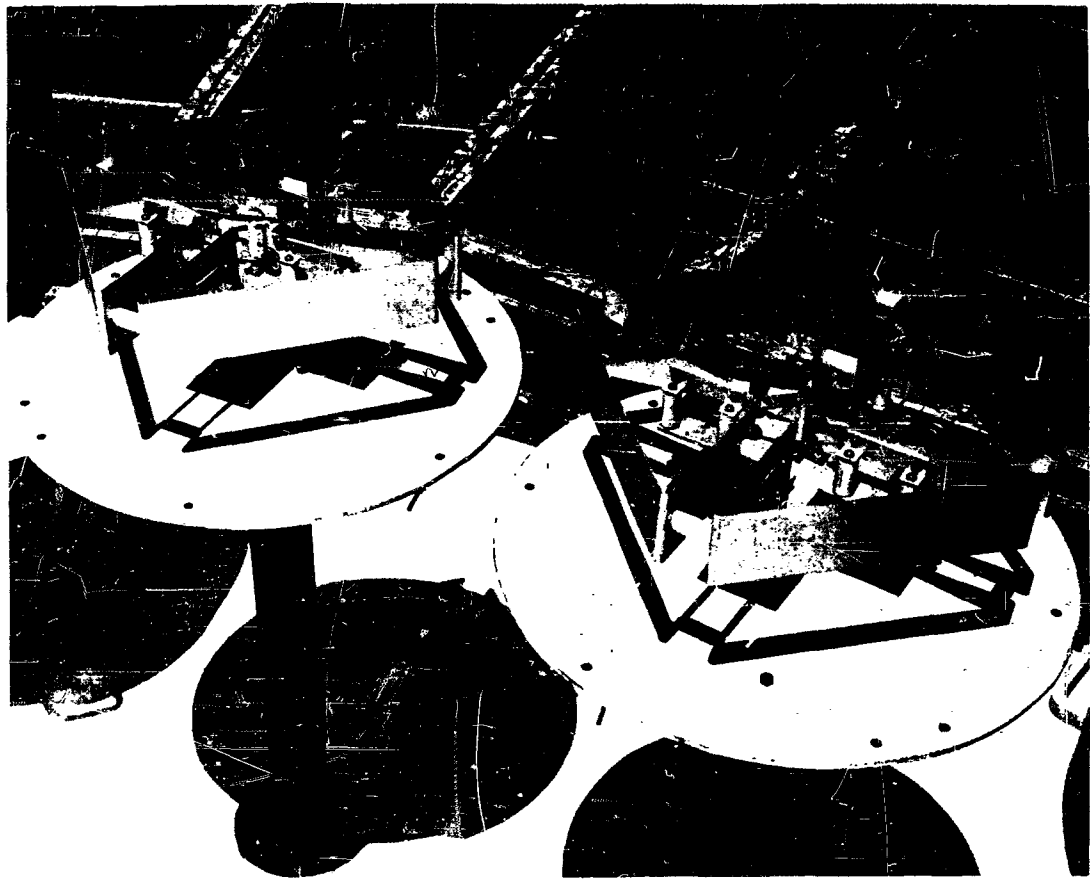

DOPPLER VOR ANTENNAS MODIFIED WITH
PARALLEL PLATE CAPACITORS—TRANSMISSION
LINE CROSSOVERS ORIENTED ALIKE

Task No. 115-02-06T

FIG. 4

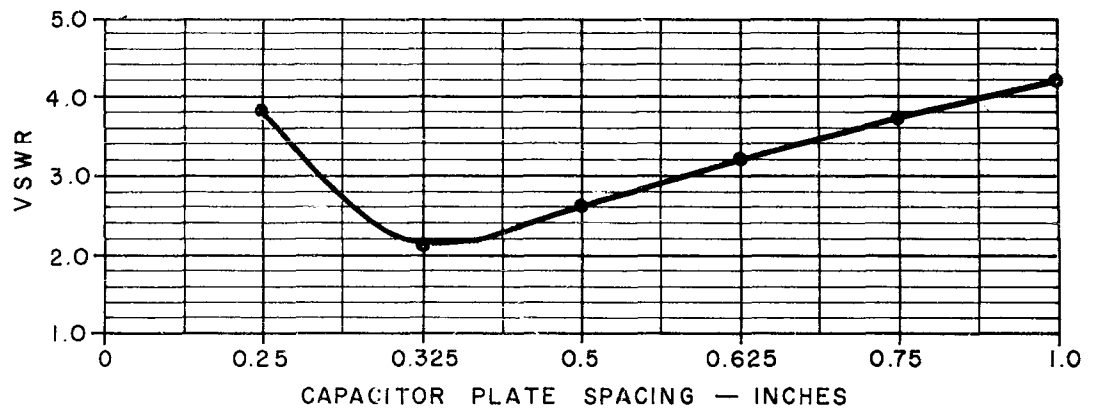
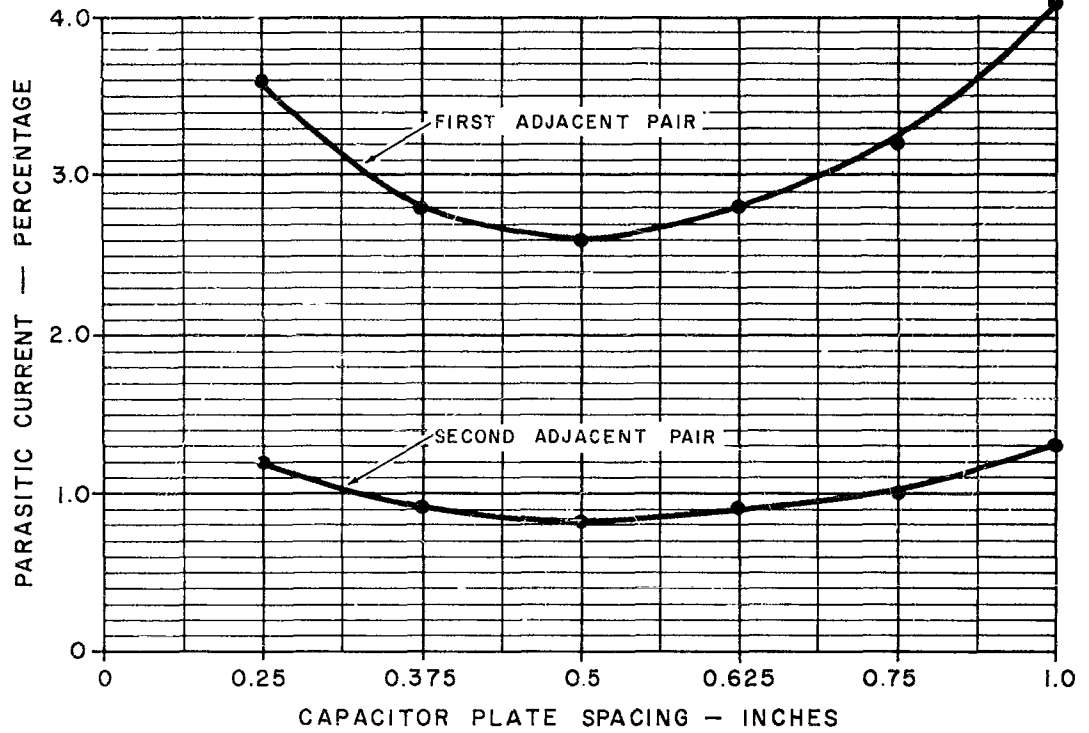

**EFFECT OF CAPACITOR PLATE SPACING
ON PARASITIC CURRENTS AND VSWR IN
LOOP ANTENNAS OF THE DOPPLER VOR**

Task No. 115-02-06T

FIG. 5

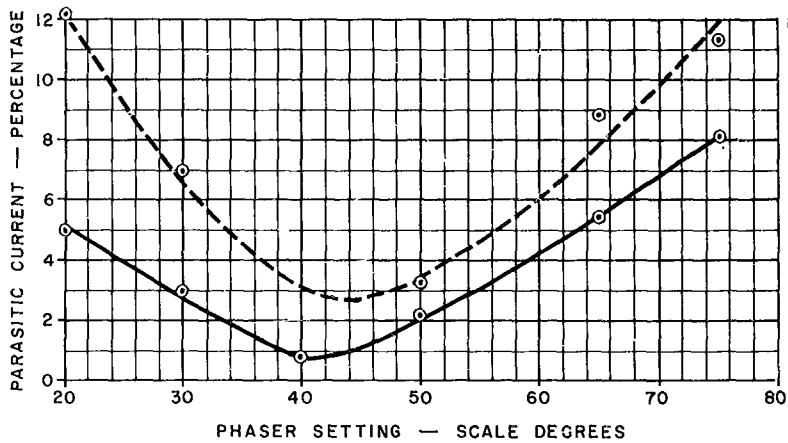
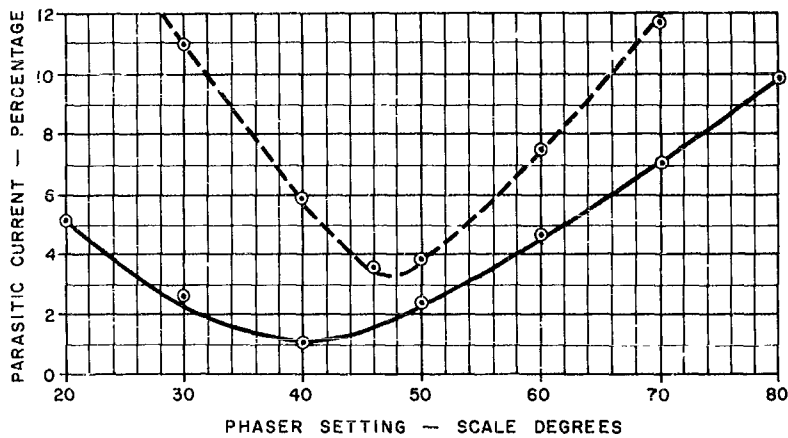

----- FIRST ADJACENT PAIR
 _____ SECOND ADJACENT PAIR

EFFECT OF TRANSMISSION LINE LENGTH ON PARASITIC CURRENTS IN LOOP ANTENNAS OF THE DOPPLER VOR

Task No. 115-02-06T

FIG. 6

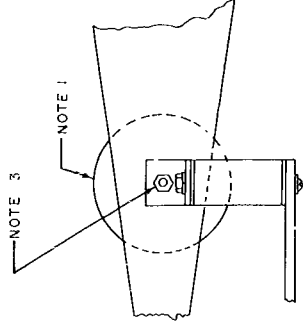
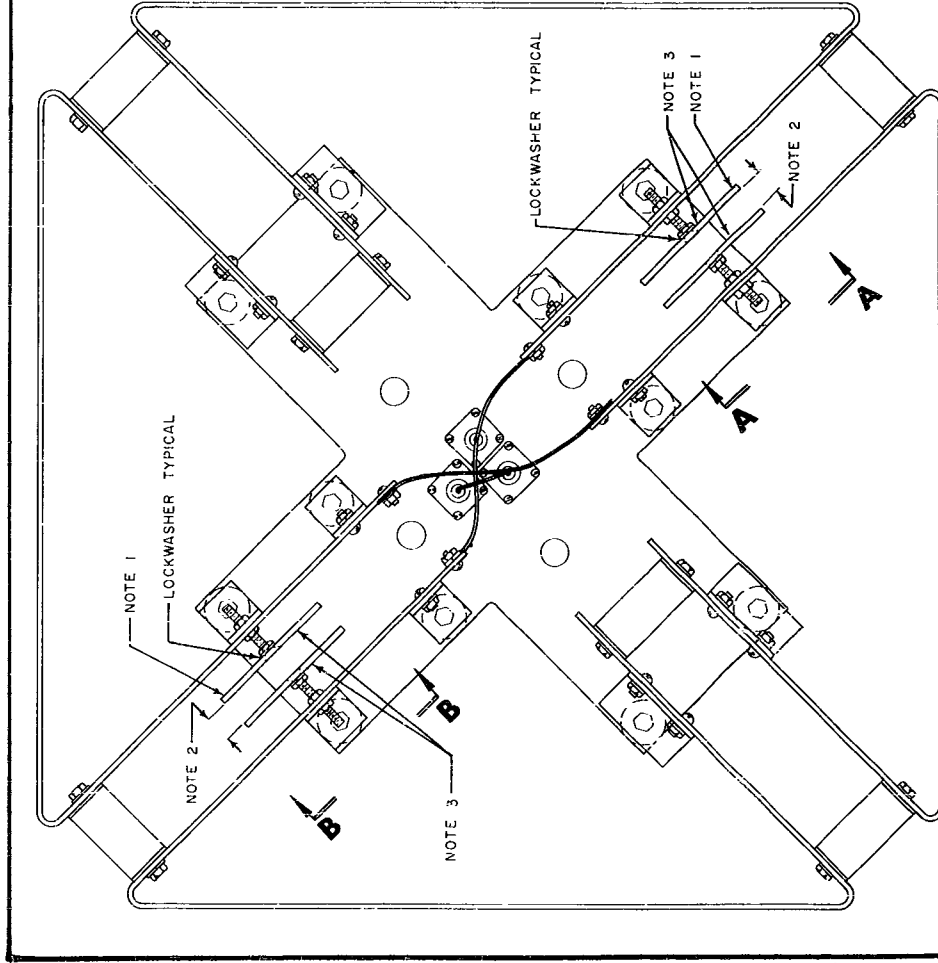

A - A AS SHOWN
B - B OPPOSITE HAND

NOTES:

- 1 THREE - INCH DIAMETER x 1/8 - INCH THICK ALUMINUM ALLOY DISC - EDGES AND SURFACES POLISHED. FOUR REQUIRED.
- 2 ADJUST TO APPROXIMATELY 1/2 - INCH
- 3 INSTALL ALUMINUM DISCS IN POSITION SHOWN USING BRASS HARDWARE LISTED BELOW
 - 4 - NO. 10-32 FLUSH HEAD SCREWS
 - 12 - NO. 10-32 NUTS
 - 4 - LOCKWASHERS.

MODIFICATION OF ALFORD BAND "B" LOOP FOR REDUCTION OF PARASITIC CURRENTS - NAFEC DOPPLER VOR

FIG. 7

UNCLASSIFIED

UNCLASSIFIED