

# **CAN CH-53K 3D TECHNICAL DATA SUPPORT THE PROVISIONING PROCESS?**

REPORT DL303T2

**LMI**

MAY 2017

# **CAN CH-53K 3D TECHNICAL DATA SUPPORT THE PROVISIONING PROCESS?**

REPORT DL303T2

Thomas K. Parks  
Dick Tiano (ATI)  
Scott Truitt (ATI)



MAY 2017

NOTICE:

THE VIEWS, OPINIONS, AND FINDINGS CONTAINED IN THIS REPORT ARE THOSE OF LMI AND SHOULD NOT BE CONSTRUED AS AN OFFICIAL AGENCY POSITION, POLICY, OR DECISION, UNLESS SO DESIGNATED BY OTHER OFFICIAL DOCUMENTATION.

LMI © 2017. ALL RIGHTS RESERVED.

## Can CH-53K 3D Technical Data Support the Provisioning Process?

DL303T2/MAY 2017

### Executive Summary

Proprietary three-dimensional (3D) technical data formats are useful for weapon system design but do not support all downstream uses of that technical data.

The Naval Air Systems Command (NAVAIR) H-53 Heavy Lift Helicopter Program Office, PMA-261, manages the CH-53K King Stallion helicopter program, currently in the Engineering and Manufacturing Development Phase of the acquisition cycle. The program intends to design, develop, and maintain the platform using 3D models documented in CATIA computer-aided design (CAD) software.<sup>1</sup> PMA-261's planned approach for delivering 3D technical data as CATIA models presents a challenge for Naval Supply Systems Command (NAVSUP) and the Defense Logistics Agency (DLA) Logistics Information Services (LIS) because their current provisioning and cataloging processes are built to accommodate and use two-dimensional (2D) technical data, not 3D models in proprietary CAD software formats.

Addressing this challenge is extremely important for NAVSUP and DLA because many other new Navy programs are taking a similar approach to 3D technical data for thousands of new parts. They, too, will soon engage NAVSUP and DLA for assistance and support. Their inability to use 3D models in proprietary CAD software formats will preclude NAVSUP and DLA LIS from conducting their provisioning and cataloging processes, effectively halting development and implementation of the requisite supply support capability for new weapon system programs.

Ultimately, the solution for the CH-53K 3D technical data challenge may become the benchmark for addressing similar challenges with other Navy and Department of Defense (DoD) weapon system acquisition programs. Accordingly, DLA wanted PMA-261 and NAVSUP to find a solution to ensure NAVSUP and DLA's ability to use CH-53K 3D technical data to support the provisioning and cataloging processes.

---

<sup>1</sup> CATIA software is Dassault Systems' proprietary 3D interactive application and product development platform for creating system design models.

---

In a previous task,<sup>2</sup> we conducted an research and development project focused on CH-53K technical data and developed a mutually acceptable solution by which PMA-261 could provide 3D technical data to DLA to support the *sustainment* process, which follows the *provisioning* and *cataloging* processes in the system life cycle. During that effort, we identified the 3D PDF file format as the preferred means for ensuring that CH-53K 3D technical data could support the sustainment process (for details, see DL303T1). We specifically noted that this format can accommodate the full product definition contained in the native CATIA models and can be easily accessed and interpreted by procurement personnel without the need to understand or use complex software applications (only Adobe Reader or Adobe Acrobat software are needed to read/navigate a 3D PDF file, and that software is already installed on most DoD computers).

For the same reasons, we find that a 3D PDF solution will resolve the issue of access and readability by NAVSUP and DLA personnel as they perform their provisioning and cataloging efforts, respectively. In addition, we and PMA-261 agree that a single solution for the CH-53K program is preferred for supporting the provisioning, cataloging, and sustainment processes.

PMA-261 agrees with the 3D PDF solution and is working with the NAVAIR enterprise to identify a funding source; the outcome is to be determined. To help PMA-261 and other program offices calculate the startup and expected annual costs of implementing a 3D PDF solution, we identified and documented the requirements and associated labor hour and cost elements. Using this information, we constructed a cost analysis tool, an Excel spreadsheet.

We conclude that CH-53K technical data issues relative to supporting the provisioning and cataloging processes are not unique. Navy and other DoD weapon system programs plan to use 3D technical data as part of a model-based enterprise approach throughout the system's life cycle. However, guidance regarding 3D data completeness and format requirements is lacking. In general, the system designers who develop the native CAD files—which should be the basis for all follow-on manufacturing and sustainment activities (provisioning, cataloging, etc.)—rarely include (or even consider) the requirements for these activities in the baseline 3D models. As development of these other weapon systems continues, more instances of 3D technical data that cannot support the provisioning and cataloging processes will arise.

We recommend DLA do the following to ensure it can catalog and subsequently procure parts using 3D technical data from any program office:

- ◆ Along with NAVSUP, continue a regular dialog with PMA-261 and monitor contract efforts and the program's ability to implement a 3D PDF solution for provisioning and cataloging, including conduct of a proposed

---

<sup>2</sup> Thomas K. Parks and Dick Tiano (ATI), *Can CH-53K 3D Technical Data Support the DLA Sustainment Process?*, DL303T1 (Tysons, VA: LMI, February 2017).

Navy MANTECH<sup>3</sup> project to demonstrate executing a 3D PDF solution amongst the CH53K program, NAVSUP, and DLA.

- ◆ Engage with select working groups to review and update technical data policy to specifically address requirements for 3D technical data formats.
- ◆ Identify and characterize other military service programs that will deliver 3D technical data to DLA in the next 5 years and identify appropriate solutions if a 3D PDF method cannot be implemented.
- ◆ Officially adopt the 3D PDF file as the desired delivery medium of 3D technical data from the services and conduct an outreach program to publicize that decision.

We recommend that PMA-261 engage NAVAIR management and seek assistance in procuring funding to support a 3D PDF enterprise solution for providing NAVSUP and LIS with CH-53K technical data to support the provisioning and cataloging processes.

If the enterprise cannot fund or implement a 3D PDF solution for the CH-53K program, we recommend that NAVAIR have PMA-261 engage DLA and NAVSUP to develop an acceptable alternative solution for providing usable technical data to support the provisioning and cataloging processes.

We recommend other program offices do the following:

- ◆ Review their program technical data deliverables and determine whether they meet the DLA characteristics and data requirements identified in Appendix A.
- ◆ If the program intends to receive and use 3D (rather than 2D) technical data, consider implementing a 3D PDF file solution as the delivery format to support the provisioning, cataloging, and sustainment processes.

---

<sup>3</sup> MANTECH is abbreviated terminology for DoD Manufacturing Technology Program.



# Contents

---

- Chapter 1 Introduction..... 1-1
  - THE PROBLEM..... 1-1
  - THE SOLUTION..... 1-2
- Chapter 2 Provisioning Process Technical Data.....2-1
  - OVERVIEW..... 2-1
  - CH-53K PROGRAM ORGANIZATIONAL ROLES..... 2-2
    - Original Equipment Manufacturer ..... 2-2
    - PMA-261 ..... 2-2
    - NAVSUP WSS..... 2-2
    - DLA LIS ..... 2-3
    - Results ..... 2-3
  - DATA REQUIREMENTS AND PROCESS FLOW ..... 2-4
    - 3D Data Requirements for Provisioning and Cataloging ..... 2-4
    - Provisioning and Cataloging Data Flow..... 2-4
- Chapter 3 3D Technical Data Solution for Provisioning .....3-1
  - THE PREFERRED SOLUTION: 3D PDF ..... 3-2
  - DATA FLOW USING 3D PDF DATA..... 3-2
- Chapter 4 3D PDF Solution Costs ..... 4-1
  - SOLUTION REQUIREMENTS..... 4-1
  - SOLUTION COSTS..... 4-2
    - Populating Native CAD Files with Sustainment Data (Requirement 1)..... 4-2
    - Annotating Native CAD Files (Requirement 2) ..... 4-2
    - Acquiring and Maintaining 3D PDF Conversion Software (Requirement 3)..... 4-3
    - Developing 3D PDF Template (Requirement 4) ..... 4-5
    - Converting Native CAD Files to 3D PDFs (Requirement 5)..... 4-5
    - Cost of CADIQ Software..... 4-7
    - Producing STEP Files (Requirement 6)..... 4-7
    - Summary ..... 4-8
  - NOTIONAL BCA FOR 3D PDF SOLUTION..... 4-8



---

Input Data for Notional BCA .....	4-9
Notional Cost of Implementing 3D PDF Solution for CH-53K.....	4-14
Chapter 5 Conclusions.....	5-1
Chapter 6 Recommendations .....	6-1
Appendix A. Requisite Technical Data for Procurement	
Appendix B. Provisioning and Cataloging Process Definitions	
Appendix C. Abbreviations	

## Tables

Table 4-1. Time Required to Annotate CAD Models (Minutes) .....	4-3
Table 4-2. Estimated 3D PDF Conversion Software Workstation Costs (\$).....	4-4
Table 4-3. Estimated Third-Party 3D PDF Conversion Software Server Costs (\$) .....	4-4
Table 4-4. Time Required to Manually Validate One 3D PDF File (Hours) .....	4-6
Table 4-5. Time Required to Validate One 3D PDF File Using CADIQ (Minutes) .....	4-6
Table 4-6. Time Required to Validate One STEP File Using CADIQ (Minutes) .....	4-7
Table 4-7. Notional Cost of Implementing a 3D PDF Solution for CH-53K (\$).....	4-14

## Figures

Figure 2-1. CH-53K Provisioning Technical Data Flow (As-Is) .....	2-5
Figure 3-1. Provisioning Technical Data Flow Using 3D PDF Data (To-Be) .....	3-3

# Chapter 1

## Introduction

---

The CH-53K King Stallion is a large, heavy-lift cargo helicopter being developed by Sikorsky Aircraft for the United States Marine Corps (USMC). It is a general redesign of the current CH-53E featuring new, more powerful engines, new lightweight composite structures, fourth generation main rotor blades, fly-by-wire flight controls, and a host of other modern design features intended to make it more intelligent, reliable, low maintenance, and survivable than its predecessors. The USMC is planning to procure about 200 CH-53Ks, which translates into thousands of parts that will require provisioning and sustainment support from organizations like the Defense Logistics Agency (DLA) and the Naval Supply Systems Command (NAVSUP).

The Naval Air Systems Command (NAVAIR) H-53 Heavy Lift Helicopter Program Office, PMA-261, manages the program, which is currently in the Engineering and Manufacturing Development Phase of the acquisition cycle. The program intends to design, develop, and maintain the CH-53K platform using three-dimensional (3D) models developed in CATIA<sup>1</sup> computer-aided design (CAD) software. PMA-261 originally planned to deliver the CATIA 3D models to NAVSUP and DLA as the requisite technical data packages to support the provisioning process for the CH-53K platform, expected to begin in the second quarter of fiscal year 2019.

## THE PROBLEM

PMA-261's planned approach for delivering 3D technical data as CATIA models presents a significant challenge for NAVSUP and DLA because their current provisioning processes are built to accommodate and use two-dimensional (2D) technical data, not 3D models. Neither NAVSUP nor DLA have any credible capability to access, view, or interpret technical data delivered as 3D models in any of the multiple, proprietary CAD software systems (CATIA, SolidWorks, CREO, NX, AutoCAD, etc.).

Addressing the challenge of using CH-53K 3D technical data to support the provisioning process is extremely important for NAVSUP and DLA because many other new weapon system programs are taking a similar approach to developing and providing only 3D technical data for thousands of new parts. They, too, will soon engage NAVSUP and DLA for provisioning assistance and support. Ultimately, the solution for the CH-53K 3D technical data challenge may

---

<sup>1</sup> CATIA software is Dassault Systems' proprietary 3D interactive application and product development platform for creating system design models.

---

become the benchmark for addressing similar challenges with other Navy and Department of Defense (DoD) weapon system acquisition programs.

## THE SOLUTION

In a previous task, DLA engaged LMI to conduct a research and development (R&D) project focused on CH-53K technical data and develop a mutually acceptable solution by which PMA-261 could provide 3D technical data to DLA to support the *sustainment* process, which follows the *provisioning* process in the system life cycle. During that effort, we became aware of the issue of using CH-53K 3D technical data to support the provisioning process, scheduled to begin in the second quarter of fiscal year 2018.

As part of the previous effort, we reviewed CH-53K CATIA models using a variety of software products, including CATIA CAD software. We assessed the ability of the existing CH-53K models to meet DLA's data requirements to support procurement actions. We explored various ways to solve the issue and identified the use of neutral file formats like 3D PDF and Standard for the Exchange of Product model data (STEP) as a solution mutually acceptable to PMA-261 and DLA. We also estimated the time and cost associated with implementing a 3D PDF solution. We documented all of our work, including our findings, conclusions, and recommendations.<sup>2</sup>

Because of contractual limitations, we could not address the *provisioning* issue as part of our previous work. DLA recognized the significant implications and immediacy of the CH-53K 3D technical data issue and awarded LMI a follow-on R&D task specifically to address the use of 3D technical data to support the provisioning process. This task builds directly upon the knowledge and insights we accumulated as part of the previous work to understand the full extent and content of the CH-53K CATIA 3D models.

This report, covering the use of CH-53K 3D technical data to support the provisioning process, is an adjunct to LMI Report DL303T1. It documents our specific research findings and conclusions regarding DLA and NAVSUP's capabilities to use 3D data, provisioning process data requirements, and the ability of the CH-53K technical data to support the provisioning and cataloging processes. Further, it recommends a mutually agreeable solution, by which PMA-261 can furnish CH-53K 3D technical data to NAVSUP and DLA in a format they can use to execute the provisioning and cataloging processes.

---

<sup>2</sup> Thomas K. Parks and Dick Tiano (ATI), *Can CH-53K 3D Technical Data Support the DLA Sustainment Process?*, DL303T1 (Tysons, VA: LMI, February 2017).

## Chapter 2

# Provisioning Process Technical Data

---

To execute the provisioning and cataloging processes, the performing activities need system design technical data that describe the various systems, subsystems, and components of the weapon system platform. Traditionally, those technical data have been delivered as 2D parts lists, 2D maintenance plans, and 2D drawings depicting the system design. For the CH-53K program, 3D models will be delivered in lieu of 2D drawings.

## OVERVIEW

“Provisioning is the process of determining and acquiring the range and quantity (depth) of repair parts, and support and test equipment required to operate and maintain an end item of material for an initial period of service. [Typically, provisioning] refers to first outfitting of a ship, unit, or a system.”<sup>1</sup> It is the first phase in developing a supply support capability for a weapon system like the CH-53K.

Provisioning is an integral part of supply chain management and closely aligned with cataloging. Cataloging is the process of systematically arranging and accounting for items with descriptive details, including “naming, describing, classifying, and assigning a unique combination of letters or numerals, or both.”<sup>2</sup> In DoD, cataloging is a prerequisite for effective supply chain management because it standardizes supplies and assets that will be recurrently procured, stocked, or distributed.

This report focuses on the technical data requirements, data formats, and data flow to support the provisioning and cataloging processes for the CH-53K program. The sections that follow describe the organizations and roles relative to the provisioning and cataloging processes, technical data requirements and formats, and current (“as-is”) process flow for the CH-53K program.

---

<sup>1</sup> Defense Acquisition University ACQuipedia, Provisioning, <https://dap.dau.mil/acquipedia/Pages/ArticleDetails.aspx?aid=8478d478-c7c8-4df2-b23d-b147f671fd44>.

<sup>2</sup> Defense Acquisition University ACQuipedia, <https://dap.dau.mil/acquipedia/Pages/ArticleDetails.aspx?aid=23ea92b1-b38b-4328-8a4e-e0ba884d2d3b>.

---

# CH-53K PROGRAM ORGANIZATIONAL ROLES

Four principal organizations are involved in the CH-53K program provisioning and cataloging processes:

- ◆ Sikorsky Aircraft, the original equipment manufacturer (OEM)
- ◆ PMA-261, the CH-53K program office
- ◆ NAVSUP Weapon Systems Support (WSS) Philadelphia, the Navy provisioning activity
- ◆ DLA Logistics Information Service (LIS), the DoD cataloging activity.

Each activity has specific responsibilities and takes actions in the provisioning and cataloging process.

## Original Equipment Manufacturer

Sikorsky Aircraft develops, designs, and delivers the CH-53K helicopter system in accordance with its government contract. This includes development of 3D models in a CATIA CAD format that completely document the system design. As the OEM, Sikorsky also develops a preliminary provisioning parts list (PPL) and a maintenance plan, which will be used to support the provisioning and cataloging processes.

## PMA-261

Among other things, the program office ensures the OEM meets its contractual requirements relative to developing and delivering technical data for the CH-53K system. PMA-261 also stores and manages that design data for subsequent use during the CH-53K life cycle.

## NAVSUP WSS

NAVSUP reviews the provisioning technical documentation and makes provisioning decisions, including determining whether an item of supply will be managed by the Navy or DLA. The provisioning technical decisions are made based on the maintenance significance of an item, how it will be used, and where it will be used. These decisions translate technical maintenance questions into language used by the supply system, and they typically are documented by assignment of codes in the PPL, such as the following:

- ◆ Should a part be stocked? (Source code)
- ◆ Who can replace a part? (Replace maintenance code)

- ◆ Who can repair a part? (Repair maintenance code)
- ◆ Who is the part disposal authority? (Recoverability code)
- ◆ What is the replacement frequency? (Replacement factor)
- ◆ What is the replacement quantity? (Minimum replacement unit)
- ◆ How important is an item? (Military essentiality code).

The process of decision making and recording—commonly called “provisioning technical coding”—is based on a thorough review of the provisioning technical documentation submitted by the OEM and the program office, including system design data.

## DLA LIS

As the DoD’s cataloging agent, DLA LIS is responsible for data strategy, management, operational control, and data support for all National Stock Number (NSN) items in the Federal Catalog System (FCS) used in supply management operations by the military services, other DoD activities, federal and civilian agencies, and foreign governments. For the CH-53K program, DLA LIS will do the following:

- ◆ Assign an item name by designating a commonly recognized noun or noun phrase to an item of supply.
- ◆ Determine the Federal Supply Class of an item of supply by establishing its relationship with other items, based on the assigned item name or physical and performance characteristics.
- ◆ Prepare and maintain an item identification by recording the characteristics data to describe the physical and performance attributes of an item of supply.
- ◆ Control item entry (filtering and scrutinizing a candidate for inclusion in the FCS) by manually and mechanically comparing a candidate to existing items and recognized standards.

## Results

The four activities perform these actions using the provisioning technical documentation submitted by NAVSUP WSS, including the updated PPL, maintenance plan, and system design documentation (3D models for the CH-53K).

As a team, they must fulfill their individual requirements and work together to develop and transfer a complete, usable set of technical data to ensure execution of

---

the provisioning and cataloging processes for the CH-53K program. Accomplishment of these processes is a prerequisite for developing and implementing a sustainable life-cycle supply support capability.

## DATA REQUIREMENTS AND PROCESS FLOW

This section describes the 3D technical data requirements, formats, and as-is technical data flow for the CH-53K program provisioning and cataloging processes.

### 3D Data Requirements for Provisioning and Cataloging

Provisioning technical documentation for the CH-53K program currently includes a PPL, maintenance plan, and system design documentation in the form of CATIA-based 3D models. The data requirements and formats for the PPL and maintenance plan are standard for DoD and have not been changed for the CH-53K program provisioning and cataloging processes. On the other hand, the CH-53K system design documentation format of CATIA 3D models (in lieu of 2D drawings) is new and has never been used by NAVSUP WSS or DLA LIS in the provisioning and cataloging processes. Accordingly, this report only addresses the data requirements and formats for the system design models.

Discussions with NAVSUP WSS and DLA LIS regarding design documentation minimum data requirements to support the provisioning and cataloging processes revealed they are basically the same as the sustainment process data requirements (Appendix A). Both organizations confirmed, if provided design data (that they can access, view, and read) that include all the characteristics and data elements in Appendix A, they will have ample detail to make informed provisioning technical decisions and adequately catalog all of the requisite CH-53K items.

### Provisioning and Cataloging Data Flow

To fully understand the provisioning and cataloging processes and interactions between the different organizations, we constructed a flow diagram for the technical data, as it would occur today—the as-is data flow (Figure 2-1). We provided copies of the diagram to PMA-261, NAVSUP, and DLA LIS, asking them to review and validate the data flow. Each activity furnished comments, which we incorporated to ensure the diagram correctly depicts the data artifacts and flow. The same organizations validated the revised diagram. (Appendix B details each diagram icon.)

Figure 2-1. CH-53K Provisioning Technical Data Flow (As-Is)

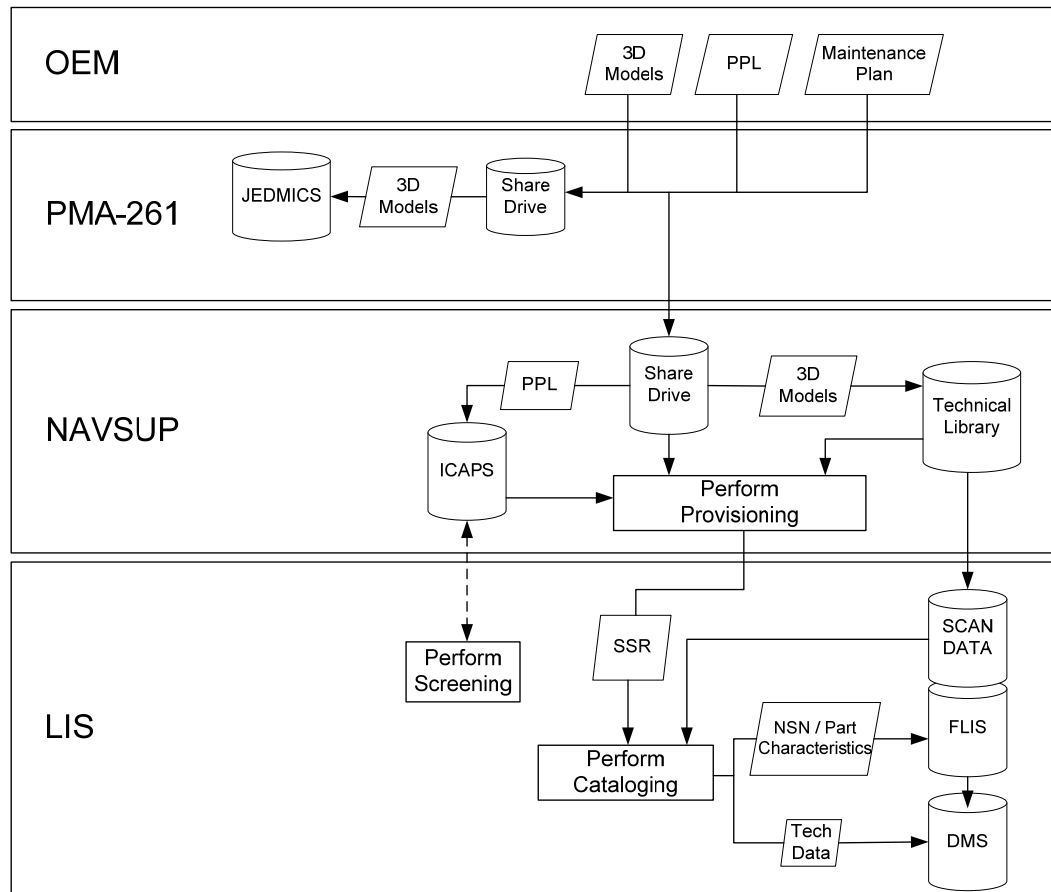

Note: DMS = Data Management System; FLIS = Federal Logistics Information System; ICAPS = Interactive Computer Aided Provisioning System; JEDMICS = Joint Engineering Data Management Information and Control System; SSR = supply support request.

The data flow between the four activities in the provisioning and cataloging processes is as follows:

- ◆ *OEM.* At the process start, the OEM creates the various technical documents (PPL, maintenance plan, and 3D models) used to support the provisioning and cataloging activities. The OEM transfers the technical data directly to PMA-261 and NAVSUP.
- ◆ *PMA-261.* The program office receives and stores the technical data on a local share drive and then reviews the documents to validate they meet the contract requirements. Subsequently, PMA-261 posts the design data (3D models) to the JEDMICS database for use during system sustainment.
- ◆ *NAVSUP.* The provisioning group at NAVSUP (WSS Philadelphia) receives, directly from the OEM, the same technical data as PMA-261. Like PMA-261, NAVSUP initially stores all of the received technical data on a local share drive. Subsequently, it transfers the PPL to the ICAPS database



---

and transfers the 3D models to its (local) technical library. NAVSUP provisioning personnel then access the technical data as necessary to review and validate OEM provisioning inputs, make appropriate provisioning technical decisions, and record those decisions in the PPL.

During the provisioning process, NAVSUP may request DLA LIS assistance (the dotted line in Figure 2-1) in reviewing the technical data to ensure they properly reflect identification of existing NSNs and to provide additional research to support provisioning technical decisions.<sup>3</sup> Following completion of the formal provisioning process activities, NAVSUP issues a SSR to DLA LIS to begin the cataloging process. NAVSUP also transfers the 3D models from its technical library to the SCAN Data digital repository.

- ◆ *DLA LIS.* Upon receipt of the SSR from the provisioning agent, DLA LIS begins the formal cataloging process. It uses the information in the SSR and design data (3D models) to make decisions on naming, describing, and numbering each item (assigning an NSN). Subsequently, the catalogers post this information to the FLIS database for use during system sustainment. They also transfer the design data (3D models) to the DMS digital repository for use by the various DLA supply centers during system sustainment.

As noted in Chapter 1, the CH-53K provisioning process is scheduled for the second quarter of fiscal year 2018. Figure 2-1 accurately depicts the data flow, data artifacts that would pass between the various organizations, data storage, and the provisioning and cataloging activities that should take place at that time.

However, neither NAVSUP nor DLA LIS can actually use the OEM-provided 3D models to perform their assigned responsibilities. Neither organization has suitable software or the associated training to use native 3D models. Thus, they cannot access and display the full product definition contained in any proprietary CAD software format (CATIA, CREO, NX, SolidWorks, AutoCAD, etc.).

Their inability to use the CH-53K CATIA models will preclude NAVSUP and DLA LIS from conducting their provisioning and cataloging processes. Both organizations agree that a different model format is needed to facilitate the processes. The next chapter presents a potential solution to the problem.

---

<sup>3</sup> Only NAVSUP, the provisioning agent, can make and issue provisioning technical decisions for the CH-53K platform. DLA LIS participation in the provisioning process is strictly in support of NAVSUP.

## Chapter 3

# 3D Technical Data Solution for Provisioning

---

In our earlier report,<sup>1</sup> we detail the current status of the CH-53K engineering data for provisioning (EDFP) design models. We found the CH-53K EDFP models could not support the DLA sustainment process. Specifically, they lack virtually all of the characteristics and data elements in Appendix A (except for geometry and some dimensional information), which contains the minimum data requirements for sustainment.

In keeping with our findings regarding the EDFP models—corroborated in an independent evaluation by the engineering support activity (ESA) at Cherry Hill—PMA-261 rejected delivery of the models and directed the OEM to modify them to include the requisite information, including tolerances, datum, and procurement metadata.

We met with representatives from NAVSUP WSS and LIS to discuss their data requirements to conduct the provisioning and cataloging processes, respectively. Specifically, we asked how their data needs compared with the data requirements for the sustainment process (Appendix A). Both organizations told us that the information they require from the design data is basically the same as that needed to support the sustainment process. So, if the design data documentation meets the data requirements (Appendix A) to support the sustainment process, it also will provide all of the data needed to carry out the provisioning and cataloging processes.

Assuming the OEM modifies the EDFP models to include the minimum data requirements for sustainment, the CATIA 3D models also will meet the technical data needs of the provisioning and cataloging processes as confirmed by the NAVSUP and LIS representatives. However, that solution does not solve the inability of NAVSUP and DLA to access and display the full product definition contained in the proprietary CATIA software format used to create and document the 3D design models.

Fortunately, the proposed solution for providing useable CH-53K 3D technical data to DLA to support the sustainment process (3D PDF) can also solve the similar issue of providing usable technical data for the provisioning and cataloging processes, as described below.

---

<sup>1</sup> See Note 2, Chapter 1.

---

## THE PREFERRED SOLUTION: 3D PDF

We identified a 3D PDF solution as the preferred means for ensuring that CH-53K 3D technical data could support the sustainment process (for details, see DL303T1). We specifically noted that this format can accommodate the full product definition contained in the native CATIA models and can be easily accessed and interpreted by procurement personnel without the need to understand or use complex software applications (only Adobe Reader or Adobe Acrobat software are needed to read/navigate a 3D PDF file).

For the same reasons, we find that a 3D PDF solution will resolve the issue of access and readability by NAVSUP and LIS personnel as they perform their provisioning and cataloging efforts, respectively. In addition, we and PMA-261 agree that a single solution for the CH-53K program is preferred for supporting the sustainment, provisioning, and cataloging processes.

As long as the CH-53K native CATIA design models (1) contain the minimum required data characteristics and elements (Appendix A) and (2) are fully annotated, they can be converted to 3D PDF files that contain the full product definition and are accessible and readable by NAVSUP and LIS personnel. Accordingly, the 3D PDF files can be substituted for the native CATIA 3D models as the system design data documentation, or medium, provided to NAVSUP and LIS personnel performing the provisioning and cataloging functions. The next section describes how the implementation of a 3D PDF solution will affect the provisioning and cataloging data flow and processes.

## DATA FLOW USING 3D PDF DATA

Figure 2-1 depicts the as-is technical data flow for the CH-53K provisioning and cataloging processes. It is based on the use of CATIA 3D models to convey system design data. If PMA-261 implements a 3D PDF solution consistent with its plans for supporting the sustainment process, the data artifacts and data flow will change. Accordingly, we developed a revised technical data flow depicting the new artifacts and flow process.

The overall provisioning and cataloging processes do not change with the use of 3D PDF technical data. Similarly, the PPL and maintenance plan data artifacts do not change. The principal changes relate to where the 3D PDF data artifact is created and how it is provided to NAVSUP as part of the overall data flow of technical data in the provisioning and cataloging processes. Figure 3-1 shows the projected (“to-be”) data flow for a 3D PDF solution.

The paragraphs that follow broadly describe the changes in the data flow to accommodate the implementation of a 3D PDF solution as part of the provisioning and cataloging processes. (Appendix B details the diagram icons.)

Figure 3-1. Provisioning Technical Data Flow Using 3D PDF Data (To-Be)

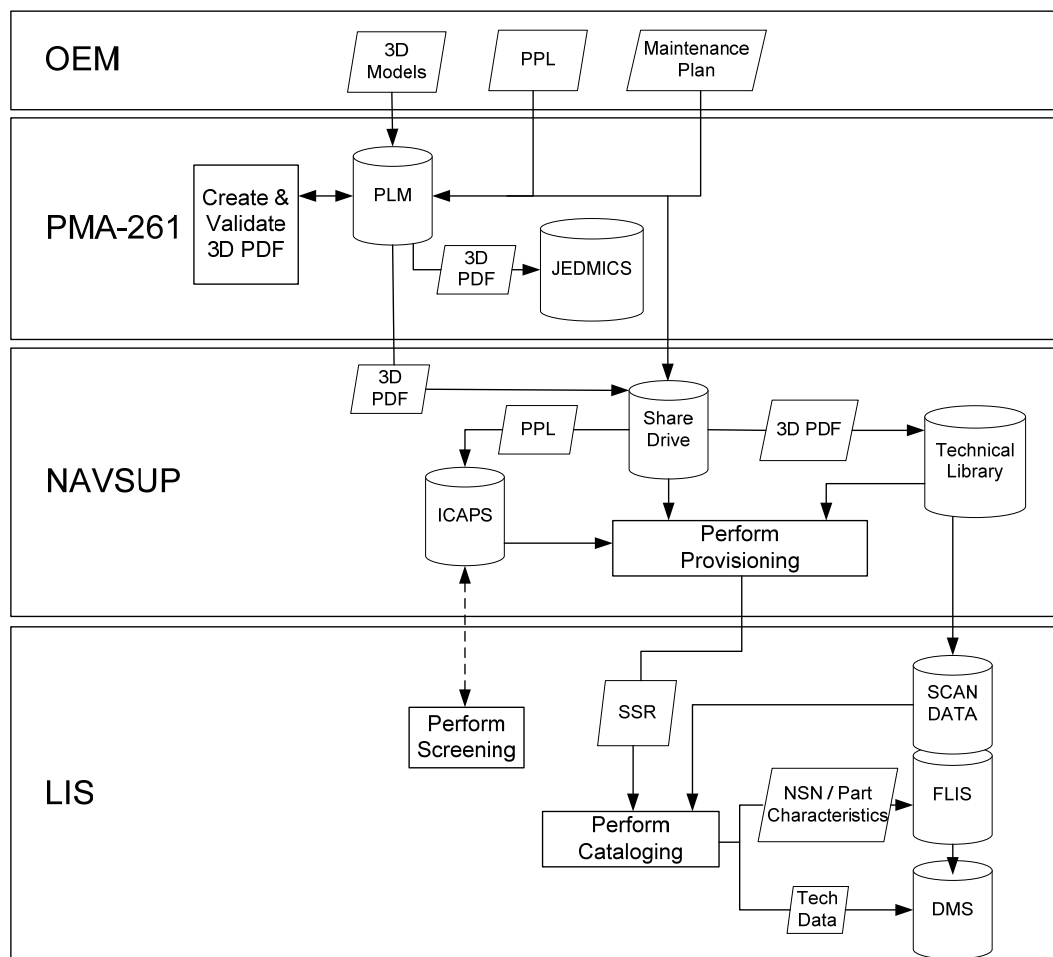

Note: PLM = product life cycle management.

The to-be data flow between the four activities in the provisioning and cataloging processes is as follows:

- ◆ *OEM.* The OEM delivers 3D models in the native CATIA format to PMA-261 only.
- ◆ *PMA-261.* The program office stores all of the OEM deliverables in a PLM system database.<sup>2</sup> The PLM system also houses the software for creating and validating 3D PDF documents and it maintains associativity between the models and other files. The program office uses the installed software to convert the native CATIA models to 3D PDF files and validate those files against the original CATIA model. It stores the 3D PDF files in the PLM system to facilitate data management during the remainder of the system life cycle. It transfers a copy of the 3D PDF files, with full associativity, to NAVSUP.

<sup>2</sup> PMA-261 planned to implement a PLM system before it considered a 3D PDF solution.

- 
- ◆ *NAVSUP*. The provisioning group at NAVSUP (WSS Philadelphia) receives the 3D PDF files directly from PMA-261 and initially stores them on a local share drive before transferring them to its (local) technical library. It uses the 3D PDF files to perform the provisioning process, and then transfers a copy of the files to the SCAN Data digital repository at LIS.
  - ◆ LIS. LIS uses the 3D PDF files to perform the cataloging process and subsequently transfer a copy of those files to the DMS digital repository for use by the various DLA supply centers during system sustainment.

Using 3D PDF files (in lieu of the native 3D models) will enable NAVSUP and LIS to perform their provisioning and cataloging responsibilities without acquiring software, licenses, and training for the various CAD software systems currently in use by the OEMs designing and building weapon systems for DoD. The use of 3D PDF files will not materially change the provisioning and cataloging process steps. However, use of 3D PDF files that meet the data requirements of Appendix A will improve the provisioning and cataloging processes because they provide a clear representation of the design intent and reduce ambiguity regarding item characteristics. The next chapter covers the cost of implementing a 3D PDF solution for the CH-53K and other DoD programs.

# Chapter 4

## 3D PDF Solution Costs

---

To help DLA, PMA-261, and other program offices that are acquiring 3D technical data estimate the cost of implementing a 3D PDF solution to support sustainment, we describe the minimum requirements and offer some cost information in the following sections. We then present a notional business case analysis (BCA) for implementing a 3D PDF solution for a program on the basis of our cost information, which we incorporated in a Microsoft Excel spreadsheet as an addendum to this report. The spreadsheet contains data elements and labor estimates for the minimum requirements discussed.

### SOLUTION REQUIREMENTS

Any program—regardless of its position in the acquisition life cycle—has six minimum requirements for implementing a 3D PDF solution to support the sustainment process:

1. Native CAD models must be fully populated with the minimum data element requirements (Appendix A).
2. Dimensions, tolerances, datum, and procurement metadata (Appendix A) included in native CAD models must be annotated.
3. A 3D PDF conversion software application must be acquired and supported.
4. A template that defines the format of the 3D PDF output file must be created, and it must include all of the sustainment data requirements (Appendix A).
5. Native CAD files for each part identified as a candidate for competitive procurement by DLA or a service sustainment activity—such as NAVSUP, Army Materiel Command, or Air Force Materiel Command—must be converted to a 3D PDF (PRC)<sup>1</sup> file and validated.
6. For each part converted to a 3D PDF file, the corresponding native CAD file must be converted to a STEP (AP203) file and validated.

---

<sup>1</sup> PRC stands for product representation compact, one of two systems used to embed 3D interactive data and models into a PDF document.

---

The next section addresses the cost associated with each of the six requirements for implementing a 3D PDF solution to support sustainment.

## SOLUTION COSTS

The costs associated with implementing a 3D PDF solution will vary from one program to the next, depending on the number and complexity of the models or parts that will be competitively procured. Final costs also depend on the actual or assumed labor rate associated with carrying out a specific requirement. For each requirement that requires manual labor, we provide an estimated time to complete the activity, which can then be multiplied by an appropriate labor rate (as designated by the program) and number of repetitions (such as models requiring conversion) to arrive at an estimated cost.

We also provide costs, collected from vendors or their websites, to procure and maintain automated software. These costs are relatively stable and consistent regardless of the program.

### Populating Native CAD Files with Sustainment Data (Requirement 1)

The OEM normally populates native CAD files with the minimum data requirements (Appendix A). It should not create any additional cost because the sustainment requirements have not changed since programs shifted to 3D technical data. (The only thing that has changed is the medium in which the data are documented and transmitted to the government.) However, if the appropriate requirements were not included in the original or current contract, there will be an additional cost, which will vary for each program on the basis of the number of parts to be competitively procured.

### Annotating Native CAD Files (Requirement 2)

The OEM normally annotates the dimensions, tolerances, datum, and procurement metadata in the native CAD models. The cost varies from program to program, depending on the number of models that require annotation and the complexity of each, measured by the number of dimensions, tolerances, and datum contained.

We took 10 unannotated CH-53K EDFP models of varying complexity, annotated them using applications included in the CATIA CAD software, and recorded the time it took. Table 4-1 shows the time required to annotate the 10 models.

Table 4-1. Time Required to Annotate CAD Models (Minutes)

EDFP model number	Annotations per model	Time (minutes)
06208-07001-101—A	3	10
D38999_20JJ35HN	15	45
HST10YV-6-5	10	30
HST1572ZAWT16	8	25
M81714_63-20F_TL	13	30
NAS1149C0332R	3	10
NAS1791C3-3	17	60
HL78-6	10	60
19205_6528256	327	960
19205_7266834	82	240

In all instances, we found that the average time to perform an annotation was about 3 minutes. Multiplying this figure by the number of dimensions, tolerances, datum, and procurement metadata in each model, and then by the estimated labor rate for the designer performing the annotations, renders an estimated cost for this activity. Assuming a labor rate of \$115 per hour,<sup>2</sup> the cost of one annotation is \$5.75, so the cost to annotate a single model that has 100 annotations is about \$575.

## Acquiring and Maintaining 3D PDF Conversion Software (Requirement 3)

The cost of acquiring and supporting a 3D PDF conversion software application varies depending on the specific application. Basically, three categories of software are used to create 3D PDF output files:

- ◆ *Software embedded in the basic CAD platform.* Most CAD platforms contain this capability at no extra cost, but the output file is generally only a tessellated image without annotated dimensions, tolerances, datum, or metadata.
- ◆ *Add-on software produced by the CAD platform developer.* This software (such as Solidworks MBD or CATIA Composer) must be procured at an additional cost.

<sup>2</sup> Market rate (loaded) for a CAD system engineer, with a BS, 8–10 years of experience, stationed in the National Capital Region, and with an 8 percent fee, as identified using the *HR3D Premium Tool*.



- ◆ *Third-party software.* This software, created by independent companies not directly owned by the CAD platform developer (such as Anark Core workstation, Tetra4D, or Lattice Technology), must be procured at an additional cost.

In the case of CATIA CAD products (the CAD software used by the CH-53K OEM), the user must purchase the CATIA Composer software and use it in conjunction with the CATIA CAD software and native CAD files to create a 3D PDF output file that can be used for sustainment. The license and maintenance costs of the CATIA Composer software are as follows:

- ◆ Perpetual License for 3DVIA Composer-Configuration (Primary License Charge)—about \$7,500
- ◆ Maintenance for 3DVIA Composer-Configuration (Annual License Charge)—about \$2,400.

For third-party software, Table 4-2 shows estimated price ranges for 3D PDF conversion software workstation solutions, which include the cost for a single instance, or seat, of the software. Table 4-3 shows estimated price ranges for third-party 3D PDF conversion software server solutions, which include the cost of the software and a limited number of seats for using the server software. The ranges are based on the different options available with each of the 3D PDF conversion software packages. The appropriate options for a given situation depend on the user’s requirements. All of the options included in these ranges can provide all the required product and manufacturing information (PMI)<sup>3</sup> needed for procurement. We obtained these prices from technical representatives at each 3D PDF conversion software company.

*Table 4-2. Estimated 3D PDF Conversion Software Workstation Costs (\$)*

Category	Anark	Lattice technology	Tetra4D
Software	12,000–16,000	7,000–22,000	500
Annual maintenance	3,000–4,000	1,500–4,000	Not applicable

*Table 4-3. Estimated Third-Party 3D PDF Conversion Software Server Costs (\$)*

Category	Anark	Lattice technology	Tetra4D
Software	93,000–115,000	26,000–115,000	Not applicable
Annual maintenance	23,000–29,000	5,000–23,000	Not applicable

<sup>3</sup> PMI may include geometric dimensions and tolerances, 3D annotation (text) and dimensions, surface finish, and material specifications.

The OEM, program office, or ESA can acquire and maintain the 3D PDF conversion software.

## Developing 3D PDF Template (Requirement 4)

For all of the 3D PDF software solutions, a template that defines the format of the 3D PDF output file must be created, and it must include all of the required data elements (Appendix A). We did not have the time or resources to build a 3D PDF template from scratch, so we collected estimates of the time required to build a template from subject matter experts (SMEs) at two private companies—Dassault and Anark—and two ESAs—U.S. Army Armament Research, Development and Engineering Center and Warner Robins Air Logistics Complex—who have built these templates.

The OEM, program office, or ESA can create a 3D PDF template. The development time for a template depends on the programmer's experience. On average, it takes about 160–320 hours to build a 3D PDF template that includes all of the sustainment data requirements and verify the output file. Building a template is a one-time nonrecurring task for the entity (OEM, program office, or ESA) charged with producing 3D PDF files, so the cost is relatively low and easily calculated as the product of the hours to build and verify the template and the labor rate for those involved in that activity. For example, if the labor rate is \$115 per hour, the cost to develop a PDF template varies between about \$18,000 and \$37,000.

## Converting Native CAD Files to 3D PDFs (Requirement 5)

The OEM, program office, or ESA can convert native CAD files to 3D PDF files, an activity that is basically a “button push.” Once the native files have been created with all the requisite data in an annotated format and the 3D PDF template has been created, virtually no labor is required beyond selecting the native CAD file and starting the conversion process. (At the very most, an engineer might spend 5 minutes selecting a model and then starting the conversion process.) If the activity has many files to convert and has acquired a 3D PDF server solution, it can batch process these files without any human intervention.

Once the 3D PDF output file is created, it should be validated manually or with the aid of validation software by the OEM, program office, or ESA. To obtain an estimate of the labor hours required to manually validate 3D PDF files, we consulted with an Air Force ESA at Warner Robins that is performing such

validations for a variety of model/file complexities.<sup>4</sup> Table 4-4 shows the estimated time in hours for manually validating 3D PDF files.

*Table 4-4. Time Required to Manually Validate One 3D PDF File (Hours)*

Part complexity			
Simple	Medium	Complex	Super complex
2-3	4-6	10-12	30-40

Assuming a labor rate of \$115 per hour, the cost to manually validate a single 3D PDF file ranges from about \$230 to \$4,600, depending on the file complexity.

We obtained a copy of the 3D PDF validation software, CADIQ, developed by International TechnoGroup Incorporated (ITI) to examine as an alternative to manually validating 3D PDF files. The CADIQ output identifies any deviations between the 3D PDF file and native CAD file used as the source file. We exercised the software by validating 3D PDF files (of varying complexities)<sup>5</sup> against the original model/file to assess CADIQ capabilities and measure the time required to perform a validation. We also obtained validation time estimates from an SME at ITI. The ITI SME estimates were consistent with our exercise results. Table 4-5 shows the estimated time, in minutes, for validating a 3D PDF file using the CADIQ automated software.

*Table 4-5. Time Required to Validate One 3D PDF File Using CADIQ (Minutes)*

Model/file complexity		
Simple	Medium	Complex
19	24	33

Assuming a labor rate of \$115 per hour, the cost to validate a single 3D PDF file using CADIQ software ranges from about \$36 to \$63, depending on the file complexity.

<sup>4</sup> A simple model/file applies to a basic item (such as a shaft, washer, or handle) documented as a one-page 2D drawing. One of medium complexity applies to a piece part or simple assembly with several parts, documented as a two- or three-page 2D drawing. A complex model/file applies to a part or assembly with many parts requiring 4 to 10 2D drawings. A super complex model/file applies to a complex part with multiple assemblies requiring more than 10 2D drawings.

<sup>5</sup> ITI classifies model/file complexity on the basis of number of resident features (shaft, washer, or handle, for example) in a model. A simple model has less than 10 features; a medium model has more than 10, but less than 25; and a complex model has more than 25.

## Cost of CADIQ Software

The CADIQ software package can be purchased as a workstation bundle or a multiprocessor server bundle. The former costs about \$27,000 and includes one license (the cost assumes the user is validating models that contain PMI); the software can be installed on many workstations. The latter costs about \$87,000 and includes two licenses for a server (the cost assumes the user is validating models that contain PMI); the software can be installed on many workstations. The advantage of the latter (the server solution) is that it can run multiple validations at the same time (perform batch processing). The annual maintenance cost for the workstation bundle is about \$5,400; for the multiprocessor bundle, it is about \$17,400.

## Producing STEP Files (Requirement 6)

Each model represented in a 3D PDF file must have a corresponding validated STEP file (AP203 format). The STEP file is necessary to provide the geometry to create the numerical control (NC) code for the NC machines used to manufacture a part. As with producing a 3D PDF file, virtually no labor is required to create a STEP file beyond selecting the native CAD file and starting the conversion process. (At most, an engineer might spend 5 minutes selecting a model and then starting the conversion process.) All major CAD platforms have a built-in capability to create and export a STEP file. The OEM, program office, or ESA can create a STEP file.

Like a 3D PDF file, the STEP file also requires validation. Because the STEP file is not in human-readable format, software validation programs are used to perform the validation. One such program is the previously mentioned CADIQ, developed by ITI. We exercised the software by validating STEP files (of varying complexities) against the original model to assess CADIQ capabilities and measure the time required to perform a validation. We also obtained validation time estimates from an ITI SME, whose estimates were consistent with our exercise results. In addition to exercising the CADIQ software and obtaining ITI SME estimates, we engaged the NAVAIR ESA at Lakehurst, which was performing STEP file validations using CADIQ. It reported the average time to validate a STEP file as about 15–20 minutes, consistent with our results and the ITI SME estimates. Table 4-6 shows the estimated time, in minutes, for validating a STEP file.

*Table 4-6. Time Required to Validate One STEP File Using CADIQ (Minutes)*

Part complexity		
Simple	Medium	Complex
17	24	35

---

The OEM, program office, or ESA can validate a STEP file. Assuming a labor rate of \$115 per hour, the cost to validate a single STEP file using CADIQ software ranges from about \$33 to \$67, depending on the file complexity.

As noted, the time to validate STEP files using CADIQ software is relatively consistent. On the other hand, the time to correct validation errors discovered using CADIQ varies greatly, depending on the specific issue and number of errors. Accordingly, furnishing a standardized estimate for correcting validation errors is impossible.

Once the 3D PDF file and associated STEP files have been validated, they must be transferred to DLA or the appropriate service sustainment activity for use as the data of record in the competitive solicitation technical data package. No additional labor or cost is associated with this action because the same process used to transfer 2D drawings is used for the transfer of 3D technical data. For example, the ESA posts the 3D PDF file and STEP file to JEDMICS, and the DLA product data specialist accesses JEDMICS and retrieves the files, which are then stored in DLA information technology systems pending development and issuance of a solicitation as part of the procurement process.

## Summary

In the preceding subsections, we identify and characterize the minimum requirements or actions necessary for a program office to implement a 3D PDF solution to support the sustainment process. We also specify the associated labor hours or costs for each requirement. As noted, the specific costs vary from program to program, depending on the number of models or files that require annotation, conversion, and validation. The labor rate assumed drives the final cost.

To assist DLA, PMA-261, and other program offices, we compiled all of the data elements for each requirement and its associated labor hours and costs into a cost analysis tool that can be used to calculate the basic and expected annual maintenance costs of implementing a 3D PDF solution. We include the tool, an Excel spreadsheet, as an addendum to this report. We used it to conduct a notional BCA for implementing a 3D PDF solution for the CH-53K program.

## NOTIONAL BCA FOR 3D PDF SOLUTION

PMA-261 and DLA are concerned about the cost of implementing a 3D PDF solution for the CH-53K Program. The OEM told PMA-261 it would cost an estimated \$10 million to convert the current 3D CATIA-based technical data “to another, less costly ‘viewable’ software program.” PMA-261 and DLA agree that the estimated cost is significant, but neither activity has a ready means to assess the validity of the OEM estimate.

In addition, PMA-261 does not know specifically what the OEM estimate covers (for example, the cost of populating native files with required sustainment data elements, cost of annotating all CH-53K parts or only CH-53K parts subject to competition, or cost of conversion software). Neither does PMA-261 yet know how many or what type of CH-53K parts will be subject to competitive procurement during the system life-cycle operations and sustainment phase. This latter fact precludes the development of an accurate BCA to corroborate or refute the OEM's \$10 million estimate.

Nevertheless, we can furnish useful cost information and a cost analysis tool (the Excel spreadsheet) as part of a notional BCA. The cost information and the tool can be easily updated and exercised to provide any program a creditable BCA as the program matures and accurate counts become available for the number and type or complexity of parts expected to be competitively procured.

## Input Data for Notional BCA

This subsection describes the specific input data used for the notional BCA. The data are based on the cost and labor figures associated with each of the six requirements for implementing a 3D PDF solution, as previously discussed.

### COST TO DEVELOP NATIVE CAD FILES

Three data elements are associated with the cost of developing native CAD files with the minimum data requirements for sustainment (Appendix A):

1. *Number of models to develop.* We assigned a value of 0 because the CH-53K contract already requires delivery of this information.
2. *Number of labor hours required to develop a model.* We assigned a value of 0 because the CH-53K contract already requires delivery of this information.
3. *Labor rate for developing the models.* We assigned a value of 0 because the CH-53K contract already requires delivery of this information.

### COST TO ANNOTATE NATIVE CAD FILES

Four data elements are associated with the cost of annotating dimensions, tolerances, datum, and procurement metadata in a native CAD file:

1. *Number of models to annotate.* We assigned a value of 10,000 as an estimate for the notional BCA because the current EDFP models were not annotated when they were developed.
2. *Average number of annotations per model.* We assigned a value of 49, which is the average number of annotations required for the 10 EDFP models we assessed.

- 
3. *Number of labor hours required to annotate a model.* We assigned a value of 0.05 hour (3 minutes) as calculated earlier in this chapter.
  4. *Labor rate for annotating the models.* We assigned a value of \$115 per hour as a conservative estimate for the notional BCA.<sup>6</sup>

### COST TO ACQUIRE 3D PDF CONVERSION SOFTWARE

One data element—the cost of conversion software—is associated with the cost of acquiring 3D PDF conversion software. We assigned a value of \$115,000; this is the cost previously identified for the Anark Core Workstation server solution and represents a conservative estimate for the notional BCA.

### ANNUAL MAINTENANCE COST FOR 3D PDF CONVERSION SOFTWARE

One data element—the annual cost of maintaining conversion software—is associated with the cost of maintaining the 3D PDF conversion software. We assigned a value of \$29,000; this is the cost previously identified for the Anark Core Workstation server solution and represents a conservative estimate for the notional BCA.

### COST TO CREATE 3D PDF TEMPLATE

Two data elements are associated with the cost of creating a 3D PDF template:

1. *Number of labor hours required to create a template.* We assigned a value of 320 hours as identified earlier in this chapter. This represents a conservative estimate for the notional BCA.
2. *Labor rate for creating the template.* We assigned a value of \$115 per hour as a conservative estimate for the notional BCA.

### COST TO CONVERT NATIVE CAD FILES TO 3D PDF FILES

Three data elements are associated with the cost of converting native CAD files to 3D PDF files using the template:

1. *Number of models to convert.* We assigned a value of 10,000 as a conservative estimate for the notional BCA.
2. *Number of labor hours required to convert a model.* We assigned a value of 0.08 hour (5 minutes) as calculated earlier in this chapter.
3. *Labor rate for converting the files.* We assigned a value of \$115 per hour as a conservative estimate for the notional BCA.

---

<sup>6</sup> See Note 2, this chapter.

## COST TO MANUALLY VALIDATE 3D PDF FILES

Nine data elements are associated with the cost of manually validating the 3D PDF files created using the template:

1. *Number of simple models that require validation.* We assigned a value of 0 because we chose to use automated validation software in lieu of manually evaluating the files.
2. *Number of medium complexity models that require validation.* We assigned a value of 0 because we chose to use automated validation software in lieu of manually evaluating the files.
3. *Number of complex models that require validation.* We assigned a value of 0 because we chose to use automated validation software in lieu of manually evaluating the files.
4. *Number of super complex models that require validation.* We assigned a value of 0 because we chose to use automated validation software in lieu of manually evaluating the files.
5. *Number of labor hours required to manually validate a simple 3D PDF file.* We assigned a value of 3 hours as identified earlier in this chapter.
6. *Number of labor hours required to manually validate a medium complexity 3D PDF file.* We assigned a value of 6 hours as identified earlier in this chapter.
7. *Number of labor hours required to manually validate a complex 3D PDF file.* We assigned a value of 12 hours as identified earlier in this chapter.
8. *Number of labor hours required to manually validate a super complex 3D PDF file.* We assigned a value of 40 hours as identified earlier in this chapter.
9. *Labor rate for validating the models.* We assigned a value of \$115 per hour as a conservative estimate for the notional BCA.

## COST TO VALIDATE 3D PDF FILES USING AUTOMATED SOFTWARE

Nine data elements are associated with the cost of validating the 3D PDF files using automated software:

1. *Cost to acquire validation software.* We assigned a value of \$87,000; this is the cost previously identified for the CADIQ software and represents a conservative estimate for the notional BCA.



- 
2. *Annual cost of maintaining automated validation software.* We assigned a value of \$17,400; this is the cost previously identified for the CADIQ software and represents a conservative estimate for the notional BCA.
  3. *Number of simple models that require validation.* We assigned a value of 3,000, which represents 30 percent of the total 10,000 models requiring validation.
  4. *Number of medium complexity models that require validation.* We assigned a value of 4,500, which represents 45 percent of the total 10,000 models requiring validation.
  5. *Number of complex models that require validation.* We assigned a value of 2,500, which represents 25 percent of the total 10,000 models requiring validation.
  6. *Number of labor hours required to validate a simple 3D PDF file using CADIQ.* We assigned a value of 0.32 hour (19.2 minutes) as identified earlier in this chapter.
  7. *Number of labor hours required to validate a medium complexity 3D PDF file using CADIQ.* We assigned a value of 0.4 hour (24 minutes) as identified earlier in this chapter.
  8. *Number of labor hours required to validate a complex 3D PDF file using CADIQ.* We assigned a value of 0.55 hour (33 minutes) as identified earlier in this chapter.
  9. *Labor rate for validating the 3D PDF files using CADIQ.* We assigned a value of \$115 per hour as a conservative estimate for the notional BCA.

## COST TO CONVERT NATIVE CAD FILES TO STEP (AP203) FILES

Three data elements are associated with the cost of converting native CAD files to STEP (AP203) files using the native CAD software utilities:

1. *Number of models to convert.* We assigned a value of 10,000 as an estimate for the notional BCA.
2. *Number of labor hours required to convert a model.* We assigned a value of 0.08 hours (5 minutes) as calculated earlier in this chapter.
3. *Labor rate for populating the models.* We assigned a value of \$115 per hour as a conservative estimate for the notional BCA.

## COST TO VALIDATE STEP FILES USING AUTOMATED SOFTWARE

Nine data elements are associated with the cost of validating the 3D PDF files using automated software:

1. *Cost to acquire validation software.* We assigned a value of \$0 because we are using CADIQ for the STEP file validations and we have already accounted for the acquisition cost of the software under the 3D PDF file validation data element.
2. *Annual cost of maintaining automated validation software.* We assigned a value of \$0 because we are using CADIQ for the STEP file validations and we have already accounted for the acquisition cost of the software under the 3D PDF file validation data element.
3. *Number of simple models that require validation.* We assigned a value of 3000, which represents 30 percent of the total 10,000 models requiring validation.
4. *Number of medium complexity models that require validation.* We assigned a value of 4,500, which represents 45 percent of the total 10,000 models requiring validation.
5. *Number of complex models that require validation.* We assigned a value of 2,500, which represents 25 percent of the total 10,000 models requiring validation.
6. *Number of labor hours required to validate a simple STEP file using CADIQ.* We assigned a value of 0.28 hours (16.8 minutes) as identified earlier in this chapter.
7. *Number of labor hours required to validate a medium complexity STEP file using CADIQ.* We assigned a value of 0.4 hours (24 minutes) as identified earlier in this chapter.
8. *Number of labor hours required to validate a complex STEP file using CADIQ.* We assigned a value of 0.58 hours (34.8 minutes) as identified earlier in this chapter.
9. *Labor rate for validating the STEP files using CADIQ.* We assigned a value of \$115 per hour as a conservative estimate for the notional BCA.

We took each of the data elements identified above, including the assigned input values, and incorporated them into an Excel spreadsheet, complete with appropriate formulas, to calculate the cost of implementing each requirement and the total cost of implementing a 3D PDF solution for the CH-53K program. We describe the results in the next subsection.

## Notional Cost of Implementing 3D PDF Solution for CH-53K

This subsection identifies the specific costs associated with each of the individual requirements for implementing a 3D PDF solution and the notional total cost of implementing that solution for the CH-53K. As discussed earlier, this is a notional BCA because we do not know how many or what type of CH-53K parts will be subject to competitive procurement during the system life-cycle operations and sustainment phase. Therefore, our estimates regarding the number of models for those parts and complexity of those models is purely a guess.

Table 4-7 shows the results of exercising the cost analysis tool (an addendum to this report) using the input data described in the previous section. Implementation requirement numbers (1, 2, 3, 4, etc.) are keyed to corresponding numbers in the cost analysis tool.

*Table 4-7. Notional Cost of Implementing a 3D PDF Solution for CH-53K (\$)*

Implementation requirement	Cost	Annual maintenance cost
1. Develop Native CAD files with minimum data requirements for sustainment	0	NA
2. Annotate dimensions, tolerances, datum, and procurement metadata in native CAD models	2,817,500	NA
3. Acquire 3D PDF conversion software	115,000	NA
4. Support 3D PDF conversion software	NA	29,000
5. Create 3D PDF template	36,800	NA
6. Convert native CAD files to 3D PDF (PRC) document using 3D PDF template	95,883	NA
7. Validate each 3D PDF document using automated software	561,375	17,400
8. Produce STEP (AP203) file corresponding to each 3D PDF file	95,833	NA
9. Validate each STEP file using automated software	472,458	NA
<b>Total</b>	<b>4,194,800</b>	<b>46,400</b>

Note: NA = not applicable.

Based on our notional BCA, the cost for implementing a 3D PDF solution for the CH-53K program is about \$4.2 million, plus annual software maintenance costs of about \$46,000. This is significantly less than the \$10 million OEM estimate, but, as previously noted, directly comparing these figures is inappropriate until PMA-261 better understands the basis for the OEM estimate.

Clearly, the largest component of the notional BCA cost is the \$2.8 million cost to annotate the dimensions, tolerances, datum, and procurement metadata in native CAD models. For the notional BCA, we assumed this action took place after the

models were originally created; that is, a design engineer went back into an existing model and annotated it. We estimate that, if the CH-53K models were annotated as part of the original model development/creation process, the time to perform an annotation would be about 50 percent (about 1.5 minutes) of the time required to annotate a model after it has been created, which we estimated at 3 minutes. The time difference is a result of the design engineer's having all the pertinent information upfront during the design process rather than having to pull data from a variety of different files, after the fact. If the models had been annotated at the time they were created, we estimate that the cost to implement a 3D PDF solution for our notional BCA would have been reduced by about \$1.4 million, saving roughly 33 percent of the overall cost.

If PMA-261 can obtain a valid estimate of the number of models required for the parts to be competitively procured and their complexity, it can adjust the appropriate data elements in the cost analysis tool and recalculate the total cost to implement a 3D PDF solution. Depending on the costs, it can then decide which of the implementing requirements the OEM should accomplish and which PMA-261 or the program's designated ESA should accomplish.



## Chapter 5

# Conclusions

---

We formed three principal conclusions from our discussions with NAVSUP, LIS, and PMA-261 regarding development of a practicable solution for providing 3D technical data to support the provisioning and cataloging processes:

1. The 3D PDF file format is the best solution for providing CH-53K 3D technical data to NAVSUP and LIS to support the provisioning and cataloging processes. Implementing this solution is also consistent with the solution that CH-53K has endorsed for solving a similar problem for sustainment. Although PMA-261 agrees with this solution, it currently does not have funds to implement it. PMA-261 is working with the NAVAIR enterprise to identify a funding source; the outcome is to be determined.
2. The overall provisioning and cataloging processes do not need to change to accommodate the use of 3D technical data if the data are provided as a 3D PDF file. The use of 3D PDF files as the documentation medium for 3D technical data will not require NAVSUP or LIS to purchase any additional software or execute extensive training.
3. The CH-53K technical data issue relative to supporting the provisioning and cataloging processes is not unique. A number of weapon system programs that started in the early 2000s plan to use 3D technical data as part of a model-based enterprise approach throughout the system's life cycle. However, detailed guidance regarding 3D data completeness and format requirements is lacking. In general, the system designers who develop the native CAD files—which should be the basis for all follow-on manufacturing, provisioning, cataloging, and sustainment activities—rarely include (or even consider) the requirements for these activities in the baseline 3D models. As development of these other weapon systems continues, more instances of 3D technical data that cannot meet the requirements to support the provisioning and cataloging processes will arise.



# Chapter 6

## Recommendations

---

On the basis of our findings (Chapters 2 through 4) and conclusions (Chapter 5), we recommend that DLA, NAVSUP, PMA-261, and NAVAIR take a series of actions to ensure DLA's capability to provision and catalog CH-53K parts using 3D technical data provided by the program office:

◆ *DLA*

- Along with NAVSUP, continue a regular dialog with PMA-261 and monitor contract efforts and the program's ability to implement a 3D PDF solution for provisioning and cataloging, including conduct of a proposed Navy MANTECH<sup>1</sup> project to demonstrate executing a 3D PDF solution amongst the CH53K program, NAVSUP, and DLA.
- Continue to engage with select working groups—DoD 3D PDF Working Group, Military Standard 31000, American Society of Mechanical Engineer (ASME) Y14 Working Group, DoD Engineering Drawing and Modeling Working Group, and the Digital Manufacturing and Design Innovation Institute—to review and update technical data policy to specifically address requirements for 3D technical data formats.
- Identify and characterize other military service programs that will deliver 3D technical data to LIS in the next 5 years and identify appropriate solutions if a 3D PDF method cannot be implemented.
- Officially adopt a 3D PDF solution as the desired delivery medium of 3D technical data from the services and conduct an outreach program to publicize that decision.

◆ *NAVSUP*

- Along with DLA, continue a regular dialog with PMA-261 and monitor contract efforts and the program's ability to implement a 3D PDF solution for provisioning and cataloging.
- Identify and characterize other Navy programs that will deliver 3D technical data for provisioning in the next 5 years and identify appropriate solutions if a 3D PDF method cannot be implemented.

---

<sup>1</sup> MANTECH is abbreviated terminology for DoD Manufacturing Technology Program.



- 
- Officially adopt the 3D PDF solution as the desired delivery medium of 3D technical data from Navy programs and conduct an outreach program to publicize that decision.
  - ◆ *PMA-261*. Engage NAVAIR management and seek assistance in procuring funding to support a 3D PDF enterprise solution for providing NAVSUP and LIS with CH-53K technical data to support the provisioning and cataloging processes.
  - ◆ *NAVAIR*. If the enterprise is unable to fund or implement a 3D PDF solution for the CH-53K program, have PMA-261 engage DLA and NAVSUP to develop an acceptable alternative solution for providing usable technical data to support the provisioning and cataloging processes.
  - ◆ *Other program offices*
    - Review program technical data deliverables and determine whether they meet the DLA characteristics and data requirements identified in Appendix A.
    - If the program intends to receive and use 3D (rather than 2D) technical data, consider implementing a 3D PDF file solution as the delivery format to support the provisioning, cataloging, and sustainment processes.

# Appendix A

## Requisite Technical Data for Procurement

---

We interviewed personnel who use technical data in their daily activities at each of the DLA supply chains—Troop Support, Land and Maritime, and Aviation. We asked them to identify specific information and information attributes they need and use to build a technical data package for inclusion in a procurement bid set.

They identified the following data elements and attributes as the minimum required data to support the procurement process, which are the same as those required in the provisioning and cataloging processes (in alphabetical order):

- ◆ *Callouts*. Additional documents necessary as references or to further define the item.
- ◆ *Classification (mandatory when applicable)*. The classification of the document when applicable (Top Secret, Secret, or Confidential).
- ◆ *Commercial and Government Entity (CAGE) code (mandatory)*. A five-character code, listed in Cataloging Handbook H4/H8, assigned to commercial and government activities that manufacture or develop items, or provide services or supplies for the government. When used with a drawing number or part number, the CAGE code designates the design activity from whose series the drawing or part number is assigned. The CAGE code was previously called “manufacturers code,” or “Federal Supply Code for Manufacturers” (ASME Y 14.24M). For the commercial sector, where there is no requirement for the CAGE code, the block may be eliminated.
- ◆ *Completeness*. Completeness and accuracy of the data in describing the design; subassemblies; component parts; materials; special processes; critical, major, and minor characteristics; functional specification; tolerances; and scale in adequate detail to fully define the item being produced.
- ◆ *Control code*. Metadata field indicating the two alpha activity code of the design activity.
- ◆ *Dimensions (mandatory)*. A numerical value expressed in appropriate units of measure and indicated on a drawing and in other documents—along with lines, symbols, and notes—to define the size or geometric characteristic, or both, of a part or part feature.

- 
- ◆ *Document approval (mandatory)*. The design activity verification that the engineering drawings and associated lists are technically accurate, in conformance with all requirements, and have been approved. Approval is signified in the signature block on the original by signature or approval indicator established by the design activity. An approval indicator may be any symbol adopted by the design activity. A signature or approval indicator may be either handwritten or electronically affixed as long as it is unique to an individual, capable of verification, and under the individual's sole control.
  - ◆ *Document data code*. A code within the metadata that further defines the document type (detailed drawing, vendor item control, parts list, application list, etc.).
  - ◆ *Document number*. Letters, numbers, or a combination of letters and numbers, which may or may not be separated by dashes. The number assigned to a particular drawing and the CAGE code provide a unique drawing identification. The drawing number is assigned from numbers controlled by the design activity whose CAGE code is assigned to the drawing.
  - ◆ *Document title*. The name by which the part or item will be known, consisting of a basic item name, government type designator, if applicable, and sufficient used trademarked names and the words ASSEMBLY (ASSY), SUBASSEMBLY (SUBASSY), or INSTALLATION (INSTL). Abbreviations may be used in the second part of the title. ASME Y14.38 lists approved abbreviations, but in general, their use should be avoided.
  - ◆ *Expiration date*. The date by which a technical data package must be reviewed and revalidated.
  - ◆ *Export control (mandatory)*. A restriction that regulates the export of data, software, or materials outside the United States to protect against the release of critical technology.
  - ◆ *Finishes*. Data requirements that describe the nature of a surface finish, surface texture, or surface topography.
  - ◆ *First article test requirements*. Preproduction testing, inspection, and reporting required to ensure a manufacturer is capable of producing an item in compliance with the contractual requirements.
  - ◆ *Heat treatment*. Requirements that describe the processes for the specific purpose of altering material properties.
  - ◆ *Higher-level contract quality requirements*. Designation that Federal Acquisition Regulation 52.246-11, Higher-Level Contract Quality Requirement, is required.

- ◆ *Inspection requirements.* The inspections and tests necessary to substantiate that the supplies or services furnished under contract—including all critical, major, or minor characteristics—conform to contract requirements.
- ◆ *Legibility.* All data prepared or submitted meet the legibility and reproducibility requirements of the specification or standard controlling the media in which the data are to be delivered. As a minimum, all lines, symbols, letters, and numerals are readable.
- ◆ *License agreement (mandatory when applicable).* An agreement between the data owner and the government that defines the government's rights to use the data.
- ◆ *Materials (ballistics).* Materials, processes, and protective treatment necessary to meet the design requirements of an item, which are identified on the drawing or parts list by reference to the item identification, identification cross-reference, or the applicable specifications or standards, including type, grade, class, or condition as applicable. The revision or amendment symbol of the specification or standard is not indicated unless it can be established that a particular revision level or existing amendment has a critical relationship to drawing interpretation or item function. Additional reference to other equivalent specifications is permitted.
- ◆ *NSN.* A National Stock Number is simply the official label applied to an item of supply that is repeatedly procured, stocked, stored, issued, and used throughout the federal supply system. It is a unique item-identifying series of numbers. When an NSN is assigned to an item of supply, data are assembled to describe the item.
- ◆ *Nuclear.* Metadata indication of nuclear technology requirements (nuclear hardness, nuclear propulsion, etc.).
- ◆ *Part number.* The identifier assigned by the original design activity, or by the controlling nationally recognized standard, that uniquely identifies (relative to that design activity) a specific item.
- ◆ *Restrictions (mandatory).* Classification, export control, limited data rights, limited distribution, or any other requirement that would restrict distribution of the document.
- ◆ *Revision and date (mandatory).* Changes made to an original drawing or associated document after authorized release that require the revision level to be advanced.
- ◆ *Revision type.* Metadata indication of whether the revision level is identified by alpha numeric or date only.

- 
- ◆ *Rights in data (mandatory)*. Proprietary restrictions, such as limited rights and licensing rights, are marked on applicable drawing sheets with the appropriate approved legend. Care is taken to ensure the legend is delineated in the field of the drawing, within the margins. On drawings that are reproduced in segments, the legend should appear in each segment. Drawings in book-form need only delineate the legend on the title sheet.
  - ◆ *Security code*. Metadata field indication of the security level (Confidential, Secret, or Top Secret) of classified documents.
  - ◆ *Size of drawing, number of sheets, frames*. Format size designation letter according to ASME Y14.1. Drawing size does not apply to 3D PDF.
  - ◆ *Sources*. The “approved” or “suggested” sources are identified when required for the drawing type per ASME Y.14.24.
  - ◆ *Specifications*. A document that describes essential technical requirements for material and the criteria for determining whether those requirements are met.
  - ◆ *SUBSAFE*. Metadata indication of Navy Submarine SUBSAFE Program requirements.
  - ◆ *Tech data availability code*. Metadata field indicating the overall availability or condition of the data (legibility, classification, limited rights, etc.).
  - ◆ *Temper*. Requirements that describe the degree of hardness and elasticity in the material.
  - ◆ *Tolerances (mandatory)*. The total amount by which a specific dimension is permitted to vary. The tolerance is the difference between the maximum and minimum limits.
  - ◆ *Welding requirements*. Requirements via notes, symbols, and annotations, or specifications that describe the welding processes.

# Appendix B

## Provisioning and Cataloging Process Definitions

---

Figure 2-1 and Figure 3-1 contain a variety of icons representing the various data artifacts and procedure steps that occur during the provisioning and cataloging processes. This appendix details each of the icons (listed in alphabetical order):

- ◆ *3D Models*. Technical data—such as part/assembly diagrams and illustrations, including dimensions, tolerances, and finish—documented as a 3D model derived from the OEM native CAD software package (CATIA, for example) used to create the system design.
- ◆ *3D PDF*. A document (ISO standard 32000) that displays 3D technical data and PMI in a PRC format. A neutral file format, 3D PDF can be read using Adobe Acrobat or (free) Adobe Reader software, enabling the information to be easily shared across many organizations without the need to purchase expensive software or training. The format enables the user to pan, tilt, zoom, and rotate the geometric object depicted in the file. A 3D PDF document is a validated derivative of the native CAD model that defines the system/equipment design and includes geometry, PMI, and other relevant technical information, including procurement metadata, to support the provisioning, cataloging, and sustainment processes.
- ◆ *Create and Validate 3D PDF*. Process of converting a 3D model from its native CAD format (CATIA, for example) into a PDF neutral file format. Conversion includes using designated 3D PDF conversion software to apply a template that defines the format of the 3D PDF output file. After the conversion process, the converted 3D PDF file is validated against the 3D native CAD model to ensure proper transfer of geometry, PMI, and other relevant technical information, including procurement metadata to support the provisioning, cataloging, and sustainment processes.
- ◆ *DMS*. The DMS is a computer application that interacts with users, other applications, and databases to capture, store, and analyze data. The DMS stores drawings/3D models and other provisioning technical documentation used to convey design, development, production, manufacture, assembly, operation, repair, testing, maintenance, or modification information regarding system/equipment parts. The system is used by product data specialists at DLA procurement centers (such as Land and Maritime, Aviation, and Troop Support) to identify and assemble a technical data package (TDP) describing the technical characteristics of a specific part. The

---

TDP is included in a solicitation requesting supplier bids for the manufacture of the specific part. Subsequently, the TDP becomes part of a contract and forms the basis for determining whether the manufactured item meets the required technical characteristics.

- ◆ *FLIS*. The FLIS is the foundation for all U.S. government logistics information systems. It contains information for more than 16 million supply items used by the U.S. government and its North Atlantic Treaty Organization (NATO) partners. FLIS provides a cross-referenced list of NSNs, manufacturer part numbers, and CAGE codes supplemented with related technical data, including an alternate parts breakdown list. It also contains a list of registered users, acquisition advice code, unit price, unit of issue, source of supply, freight data, and hazardous material indicators, interchangeable and substitutable information.
- ◆ *ICAPS*. The ICAPS is a data management system that stores, manages, and distributes provisioning data in various formats. The provisioning data summaries contain information the government needs to assess design status, conduct logistics planning and analysis, influence program decisions, and verify that contractor performance meets system supportability requirements.
- ◆ *JEDMICS*. The JEDMICS is a DoD standard engineering data management and repository system. JEDMICS provides the means to efficiently convert, store, protect, process, locate, receive, and output information previously contained on aperture cards and paper. Large engineering drawings and related text are scanned and stored on network-accessible digital media, providing online access at distributed workstations. JEDMICS is also DoD's standard repository system for digitized engineering drawings (3D models) and provides the capability to accept data directly from various other digital media processes. It is a joint service program of record with the joint program office residing within NAVAIR (AIR 6.8.4.1).
- ◆ *Maintenance Plan*. The foundation document for logistics support planning. It provides overall guidance on how maintenance will be performed, the level at which it will be performed (organizational, intermediate, or depot), and the support requirements at each level. Maintenance plans typically are distributed to the cognizant program support inventory control point, cognizant field activities, logistics managers, logistic element managers, operational commanders (who will use the fielded the equipment), and other logistics support activities for implementation.
- ◆ *NSN/Part Characteristics*. The NSN is a unique 13-digit numeric code, used to identify standard material items of supply for NATO and DoD. Part characteristics of an item provide detailed item descriptions, including

information such as materials, dimensions, colors, conditions, and performance characteristics of supply parts. Also included are several data elements that identify usage, who manages the item, and how to dispose of the item at the end of its life cycle.

- ◆ *Perform Provisioning.* Provisioning is the process of determining and acquiring the range and quantity (depth) of repair parts and support and test equipment required to operate and maintain an end item of material for an initial period of service. The provisioning process makes technical decisions on each part by addressing a series of maintenance questions. Answers to these technical maintenance questions translate into language used in the supply system. Typical maintenance questions include “Should the part be stocked?” “Who can replace the part?” “Who can repair the part?” “Who is the disposal authority?” “What is the expected replacement frequency?” “What is the expected replacement quantity?” and “What preventive maintenance is required?” Once made, the technical decisions are recorded by the assignment of codes associated with each part.
- ◆ *Perform Screening.* A comprehensive review of available technical data to identify incomplete, incorrect, or duplicate information that might hamper the cataloging process. Screening is an optional service available through DLA LIS that must be specifically requested by the provisioning activity (such as NAVSUP); it is normally conducted early in the provisioning process.
- ◆ *PLM.* A PLM system is a data management system that stores, manages, and distributes data and design information (such as 3D models, maintenance plans, or PPLs) associated with the life of a product from concept development, to system design, to manufacture/production, and through system sustainment to its retirement and disposal.
- ◆ *PPL.* Portrays the physical composition of the system or equipment. It is a list of parts that make up the complete assembly of the finished product. It includes all items subject to wear or failure and other items required for maintenance throughout the expected life cycle of the end item. Parts are listed in a logical order, such as a top-down-breakdown or circuit symbol sequence. For each part, the PPL shows information such as the part number, part name, and quantity of the part in the equipment, unit price of the item, etc. The PPL is the basic document used in the provisioning process for recording various technical decisions regarding the maintenance significance of an item, how it will be used, and where it will be used.
- ◆ *Share Drive.* Access-controlled digital storage repository located and available via a local area network. The share drive is accessible only by personnel associated with the activity that owns it. It is used to store various forms of technical data.



- 
- ◆ *Technical Library.* NAVSUP-controlled digital storage repository available via a local area network. It is used to store drawings and 3D models for weapon systems and equipment for which NAVSUP is the cognizant provisioning activity.
  - ◆ *SSR.* The SSR is a formal document sent by a provisioning activity (such as NAVSUP) to LIS, requesting issuance of new NSNs for appropriate items and informing DLA of added supply requirements for existing NSNs. The SSR initiates the cataloging process.
  - ◆ *Perform Cataloging.* The process of creating an NSN for each part used to maintain a weapon system/equipment. Cataloging serves as the foundation of the DoD supply chain, ensuring information on each part is provided in a way that enables supported activities to easily understand and use it. Cataloging includes naming, describing, and numbering each item recurrently used, bought, stocked, or distributed by the DoD, other federal agencies, and international allies.
  - ◆ *SCAN DATA.* LIS-controlled digital storage repository used to store NATO, U.S. military service, and manufacturer systems/equipment drawings and models to support cataloging activities.
  - ◆ *Tech Data.* Information used to catalog and assign an NSN. It includes drawings/3D models and other provisioning technical documentation used to convey design, development, production, manufacture, assembly, operation, repair, testing, maintenance, or modification information regarding system/equipment parts.

# Appendix C

## Abbreviations

---

2D	two-dimensional
3D	three-dimensional
ASME	American Society of Mechanical Engineers
BCA	business case analysis
CAD	computer-aided design
CAGE	Commercial and Government Entity
DLA	Defense Logistics Agency
DoD	Department of Defense
DMS	Data Management System
EDFP	engineering data for provisioning
ESA	engineering support activity
FCS	Federal Catalog System
FLIS	Federal Logistics Information System
ICAPS	Interactive Computer Aided Provisioning System
ITI	International TechneGroup Incorporated
JEDMICS	Joint Engineering Data Management Information and Control System
LIS	Logistics Information Services
MANTECH	DoD Manufacturing Technology Program
NATO	North Atlantic Treaty Organization
NAVAIR	Naval Air Systems Command
NAVSUP	Naval Supply Systems Command
NA	not applicable
NC	numerical control
NSN	National Stock Number
OEM	original equipment manufacturer
PLM	product life cycle management
PMI	product and manufacturing information

---

PRC	product representation compact
PPL	provisioning parts list
R&D	research and development
SME	subject matter expert
SSR	supply support request
STEP	Standard for the Exchange of Product model data
TDP	technical data package
USMC	United States Marine Corps
WSS	Weapon Systems Support

# REPORT DOCUMENTATION PAGE

*Form Approved*  
**OMB No. 0704-0188**

Public reporting burden for this collection of information is estimated to average 1 hour per response, including the time for reviewing instructions, searching existing data sources, gathering and maintaining the data needed, and completing and reviewing this collection of information. Send comments regarding this burden estimate or any other aspect of this collection of information, including suggestions for reducing this burden to Department of Defense, Washington Headquarters Services, Directorate for Information Operations and Reports (0704-0188), 1215 Jefferson Davis Highway, Suite 1204, Arlington, VA 22202-4302. Respondents should be aware that notwithstanding any other provision of law, no person shall be subject to any penalty for failing to comply with a collection of information if it does not display a currently valid OMB control number. **PLEASE DO NOT RETURN YOUR FORM TO THE ABOVE ADDRESS.**

<b>1. REPORT DATE (MM-YYYY)</b> 05-2017		<b>2. REPORT TYPE</b> Final		<b>3. DATES COVERED (From - To)</b>	
<b>4. TITLE AND SUBTITLE</b> Can CH-53K 3D Technical Data Support the Provisioning Process?				<b>5a. CONTRACT NUMBER</b> SP4701-09-D-0045	
				<b>5b. GRANT NUMBER</b>	
				<b>5c. PROGRAM ELEMENT NUMBER</b>	
<b>6. AUTHOR(S)</b> Parks, Thomas K Tiano (ATI), Dick Truitt (ATI), Scott				<b>5d. PROJECT NUMBER</b>	
				<b>5e. TASK NUMBER</b>	
				<b>5f. WORK UNIT NUMBER</b>	
<b>7. PERFORMING ORGANIZATION NAME(S) AND ADDRESS(ES)</b>  LMI 7940 Jones Branch Drive Tysons, VA 22102				<b>8. PERFORMING ORGANIZATION REPORT NUMBER</b> DL303T2	
<b>9. SPONSORING / MONITORING AGENCY NAME(S) AND ADDRESS(ES)</b> Defense Logistics Agency (J34) 8725 John J. Kingman Road Fort Belvoir, VA 22060-6221				<b>10. SPONSOR/MONITOR'S ACRONYM(S)</b>	
				<b>11. SPONSOR/MONITOR'S REPORT NUMBER(S)</b>	
<b>12. DISTRIBUTION / AVAILABILITY STATEMENT</b> A Approved for Public Release					
<b>13. SUPPLEMENTARY NOTES</b>					
<b>14. ABSTRACT</b> The CH-53K King Stallion helicopter program intends to design, develop, and maintain the platform using three-dimensional (3D) models documented in CATIA computer-aided design (CAD) software. The program's planned approach for delivering 3D technical data as CAD models/files to support system sustainment presents a challenge for the Naval Supply Systems Command (NAVSUP) and the Defense Logistics Agency (DLA) because their current provisioning and cataloging processes are built to accommodate and use two-dimensional technical data, not 3D models. CH-53K 3D model issues relative to supporting the provisioning and cataloging processes are not unique. A number of Navy and other developing Department of Defense (DoD) weapon system programs plan to use 3D models as part of a model-based enterprise approach throughout the system's life cycle. Unfortunately, guidance regarding 3D data completeness and format requirements is lacking. NAVSUP, DLA, and the CH53K program have identified a solution for the 3D technical data challenge that may become the benchmark for addressing similar challenges with other DoD weapon system acquisition programs. Specifically, they found that the 3D PDF file format is the best solution for providing CH53K 3D technical data to support provisioning, cataloging, and sustainment.					
<b>15. SUBJECT TERMS</b> CH53K; 3D; Technical Data; CAD; Sustainment; Provisioning; Cataloging; Acquisition; DLA; NAVSUP					
<b>16. SECURITY CLASSIFICATION OF:</b>			<b>17. LIMITATION OF ABSTRACT</b>	<b>18. NUMBER OF PAGES</b>	<b>19a. NAME OF RESPONSIBLE PERSON</b>
<b>a. REPORT</b> UNCLASSIFIED	<b>b. ABSTRACT</b> UNCLASSIFIED	<b>c. THIS PAGE</b> UNCLASSIFIED			Sara Faulk
			Unclassified Unlimited	50	<b>19b. TELEPHONE NUMBER (include area code)</b> (703) 917-7148



LMI reports offer public-sector managers practical solutions for attaining agency objectives. The solutions, informed by more than 50 years' not-for-profit service and backed by LMI's rigorous research program, may result from applying LMI models and methods or from synthesizing the knowledge of LMI's best management and technical minds. All LMI reports—whether for a targeted audience of experts, a broad cross-section of government stakeholders, or high-level government decision makers—are reviewed in compliance with LMI's ISO-certified quality management procedures.

**CONTACT:**

ERIC L. GENTSCH  
LMI  
7940 JONES BRANCH DRIVE  
TYSONS  
VA 22102

703.917.7226

EGENTSCH@LMI.ORG